

Lawrence Berkeley National Laboratory

Recent Work

Title

ANGULAR CORRELATIONS INVOLVING CONVERSION ELECTRONS

Permalink

<https://escholarship.org/uc/item/69n8m993>

Author

Yamazaki, T.

Publication Date

1965-04-01

University of California
Ernest O. Lawrence
Radiation Laboratory

ANGULAR CORRELATIONS
INVOLVING CONVERSION ELECTRONS

TWO-WEEK LOAN COPY

*This is a Library Circulating Copy
which may be borrowed for two weeks.
For a personal retention copy, call
Tech. Info. Division, Ext. 5545*

Berkeley, California

DISCLAIMER

This document was prepared as an account of work sponsored by the United States Government. While this document is believed to contain correct information, neither the United States Government nor any agency thereof, nor the Regents of the University of California, nor any of their employees, makes any warranty, express or implied, or assumes any legal responsibility for the accuracy, completeness, or usefulness of any information, apparatus, product, or process disclosed, or represents that its use would not infringe privately owned rights. Reference herein to any specific commercial product, process, or service by its trade name, trademark, manufacturer, or otherwise, does not necessarily constitute or imply its endorsement, recommendation, or favoring by the United States Government or any agency thereof, or the Regents of the University of California. The views and opinions of authors expressed herein do not necessarily state or reflect those of the United States Government or any agency thereof or the Regents of the University of California.

Conference on Internal Conversion
Process, Vanderbilt Univ.,
Nashville, Tennessee, May 11-13,
1965. Also submitted for publi. in
the Proceedings.

UGRL-16027

UNIVERSITY OF CALIFORNIA

Lawrence Radiation Laboratory
Berkeley, California

AEC Contract No. W-7405-eng-48

ANGULAR CORRELATIONS INVOLVING CONVERSION ELECTRONS

T. Yamazaki

April 1965

ANGULAR CORRELATIONS INVOLVING CONVERSION ELECTRONS

T. Yamasaki

Lawrence Radiation Laboratory
University of California
Berkeley, California

ABSTRACT

A brief summary is made of the advantages of angular correlation involving conversion electrons and of the current state of experimental apparatus. It is emphasized that L conversion electrons in addition to K will provide important information of nuclear structure and the conversion process. Preliminary measurements on the $333 \gamma - 356$ K, L, M and 333 K, L, M $- 356 \gamma$ angular correlations in Pt^{196} are reported. A discussion is made of a possible rearrangement effect on the conversion coefficients of a nuclear transition which follows a converted transition in cascade.

ANGULAR CORRELATIONS INVOLVING CONVERSION ELECTRONS*

T. Yamazaki

Lawrence Radiation Laboratory
 University of California
 Berkeley, California

I. INTRODUCTION

Angular correlations involving internal conversion electrons are important quantities in investigating nuclear structure and the conversion process. They provide the following information which is not obtained from γ - γ angular correlations.

1) Whereas it is essentially impossible to discriminate between EL and ML transitions with γ - γ angular correlation, the dependence of both particle parameter and conversion coefficient on multipolarity allows such a discrimination to be made in angular correlations involving internal conversion electrons. This advantage has been applied to unique determinations of spins and parities of the levels and multipolarities involved in a sequence.¹ For example, γ - γ angular correlation cannot discriminate between the two cases: 1) $4^+ (E2) 2^+(E2) 0^+$ and 2) $2^+(E2 + M1, \delta = -0.19) 2^+ (E2) 0^+$. On the other hand, e^- - γ angular correlation gives quite different values for these cases. A typical experiment was performed by Sakai et al.² on the unique assignment of the $4^+ (E2) 2^+ (E2) 0^+$ sequence in Hg^{200} .

2) Since both particle parameter and conversion coefficient reflect the penetration effect,³ e^- - γ angular correlation provides additional information about this effect, independent of that obtained from conversion coefficient measurements. A series of experiments in this direction have been performed by the Uppsala group,^{4,5} and others.⁶

3) As first proposed by Church, Rose and Weneser,⁷ e^- - γ angular correlation is effected by a small admixture of E0 component in direct competition with E2 and M1 multipole radiations. Experiments of this type have been carried out on Pt¹⁹⁶ by the Uppsala group,⁸ on Os^{188,190}, Pt¹⁹⁶, and Hg¹⁹⁸ nuclei by the Tokyo group,^{9,10,11} and on Pt¹⁹² by Butt and Dutta.¹² It is worth pointing out that the three independent experimental quantities, $A_2(\gamma-\gamma)$, $A_2(e^--\gamma)$ and α_K , are still insufficient to determine q (EO/E2 mixing ratio) and λ (penetration parameter) uniquely. This point will be discussed later in connection with the possibility of using L conversion electrons.

4) In the past, when there was no high-resolution gamma-ray spectrometer applicable to angular correlation experiments, e^- - γ angular correlation used to have another merit in that a magnetic spectrometer could be used to resolve closely spaced lines. The recent development of lithium-drifted germanium gamma-ray spectrometers seems to have made this feature less important.

II. DEVELOPMENT OF e^- - γ ANGULAR CORRELATION APPARATUS

In the past, there were two kinds of e^- - γ angular correlation apparatus. One used a magnetic lens spectrometer for an electron channel, and the other used a sector-type double-focusing spectrometer. The former was developed by the Uppsala group¹³ and many others. In general a lens-type spectrometer has a transmission larger than any other type of magnetic spectrometers, while the resolution is not as good. Furthermore, the aperture of the beam is so large that the geometrical attenuation factor is considerable.

The latter was developed by Sakai, Ikegami and Yamazaki.¹⁴ In spite of its small transmission ($< 0.5\%$ of 4π) the sector-type double-focusing spectrometer has the following advantages: 1) the source is placed completely outside of the magnetic field. This makes it easier to connect a scintillation counter or another magnetic spectrometer to this. 2) It accepts a pencil beam from the source. In other words, it acts as a small rectangular-shaped detector. Therefore, the geometrical attenuation is not as great as that found in using a lens-type spectrometer. 3) It has a good characteristic of resolution versus transmission. The rectangular shape of the source is also suitable for angular correlation measurements. A schematic view of the electron-electron spectrogoniometer, which was constructed at the Institute for Nuclear Study of University of Tokyo, is shown in Fig. 1. This apparatus is capable of a large variety of measurements, such as two independent e^- - γ angular correlations, γ - γ angular correlation and e^- - e^- angular correlation.

Recently modern apparatus making use of solid-state detectors have been developed by many people. The resolution of a Si(Li) detector is so good that it can replace a magnetic spectrometer in most cases. The main restriction in the use of Si(Li) detectors is that the total counting rate be limited. So it is not suitable to negatron emitters, in which case the conversion line of interest is only a small part of the large amount of continuous beta rays. The limited size of Si(Li) detectors also restricts the size of the source very much. A lithium-drifted germanium detector can resolve two gamma rays of 3 keV separation in energy. This detector is, indeed, an epoch-making device also in angular correlation experiments.

It not only resolves complicated gamma rays but also eliminates troubles caused by scattering because of its high energy discrimination.

Figure 2 shows a schematic view of a new apparatus adopting Si(Li) and Ge(Li) detectors, which is being constructed by Yamazaki and Hollander at the Lawrence Radiation Laboratory of the University of California and is partly in operation. A 3 cm x 2 cm x 10 mm deep Ge(Li) crystal is used as fixed gamma-ray counter and a 14 mm ϕ x 3mm thick Si(Li) as a fixed electron spectrometer. When high resolution is required for the electron channel, in such a case as in resolving L subshell lines, the Si(Li) detector can be replaced by the Berkeley 50-cm radius $\pi\sqrt{2}$ type iron-free spectrometer. The detector system of the iron-free spectrometer will consist of 4 rectangular shape Si(Li) detectors placed along a focal plane so that it may accept L subshell lines simultaneously. A 2" ϕ x 2" NaI(Tl) spectrometer is temporarily being used as a movable counter. In the near future this scintillation counter is to be replaced by a multi-detector unit consisting of 4 Ge(Li) crystals. With this apparatus $e^- - \gamma$ and $\gamma - \gamma$ angular correlations can be measured simultaneously. A series of 10 single-channel analyzers select the pulse height of the movable counter. Singles counts and two-dimensional coincidence counts for each of four positions (altogether 10 x 10 x 4 bits of information) are stored in the magnetic core memory of a 400 channel pulse height analyzer. This electronics system has been made by Goulding and Landis.

Since the two fixed spectrometers select a gamma ray and the corresponding conversion electron lines with good resolution, the ratio of two angular correlation functions provides very good information on the

transition detected by the fixed detectors, that is,

$$\frac{A_{\nu}^{(i)}(e^{-\Sigma\gamma'})}{A_{\nu}(\gamma-\Sigma\gamma')} = \frac{F_{\nu}(e_i)}{F_{\nu}(\gamma)}$$

where i denotes an electron shell (K, L, etc). If the transition in question is of pure multipole order, then this quantity is a particle parameter itself. A project to determine particle parameters for not only K but also L subshell electrons is in progress.

The use of a Si(Li) detector makes it very easy to measure angular correlations involving K, L and M conversion electrons simultaneously. The significance of angular correlations involving L conversion electrons will be discussed in next sections.

III. SIGNIFICANCE OF L CONVERSION ELECTRONS IN ANGULAR CORRELATION

In earlier states of angular correlation experiments only K conversion electrons were involved. One of the reasons for this is that there were no theoretical particle parameters available for L conversion electrons. Another reason is the experimental situation which existed in the past. Now these circumstances seem being overcome. Actually, theoretical values have been published¹⁴ and are getting more and more available.

The advantage of the angular correlation using L conversion electrons is that it adds three (if subshell electrons are resolved) or at least one (if integrated L electrons are involved) more bits of information to $e_K+\gamma$ and $\gamma-\gamma$ angular correlations.

Let us take for example the case of a $2^+ (E2 + M1 + E0) 2^+ (E2) 0^+$ cascade. The γ - γ angular correlation function is

$$A_2(\gamma-\gamma, E2 + M1 + E0) = \frac{1}{1 + \delta^2} [A_2^e + 2\delta A_2 + \delta^2 A_2^m]$$

and e- γ angular correlation function for each shell "i" is expressed as follows:⁷

$$A_2^{(i)}(e-\gamma, E2 + M1 + E0) = \frac{1}{1 + p_i^2 + q_i^2} [b_2^{(i)}(E2) A_2^e + 2p_i b_2^{(i)}(M1 - E2) A_2 + p_i^2 b_2^{(i)}(M1) A_2^m + q_i b_2^{(i)}(E0 - E2)],$$

where

$$q_i = \sqrt{\frac{\Omega^{(i)}(Z, k)}{\alpha_2^{(i)} W_\gamma(E2)}} \rho,$$

$$p_i = \sqrt{\frac{\beta_1^{(i)}}{\alpha_2^{(i)}}} \delta$$

Here p_i , q_i , $b_2^{(i)}(M1 - E2)$ and $b_2^{(i)}(M1)$ are functions of the unknown parameters ρ (E0 strength parameter), and δ and λ . As pointed out in Section I, α^K , $A_2(\gamma-\gamma)$ and $A_2^K(e-\gamma)$ cannot determine these parameters uniquely. $A_2^L(e-\gamma)$ and α^L will remove the ambiguity, because these quantities are independent of $A_2^K(e-\gamma)$ and α^K . For simplicity, let us assume that $p_i \ll 1$ and $q_i \ll 1$. Then the sensitivity of $A_2^{(i)}$ to δ and ρ is

expressed by

$$\frac{\partial A_2^{(i)}}{\partial \delta} = 2b_2^{(i)} (M1 - E2) A_2 \sqrt{\frac{\beta_1^{(i)}}{\alpha_1^{(i)}}},$$

$$\frac{\partial A_2^{(i)}}{\partial \rho} = b_2^{(i)} (E0 - E2) \sqrt{\frac{\Omega^{(i)}(Z,k)}{\alpha_2^{(i)} W_\gamma(E2)}}.$$

For example, when $Z = 81$ and $k = 0.6$,

$$\frac{\partial A_2^K}{\partial \delta} = 0.377 \times 2A_2$$

$$\frac{\partial A_2^{L_I}}{\partial \delta} = 0.625 \times 2A_2$$

$$\frac{\partial A_2^{L_{II}}}{\partial \delta} = 0.370 \times 2A_2.$$

This example shows that $e_L^- - \gamma$ angular correlation is quite promising.

IV. PRELIMINARY RESULTS ON THE ANGULAR CORRELATIONS IN Pt¹⁹⁶

For the purpose of showing the applicability of L conversion electrons, measurements on 333 γ - 356 K, L, M and 333 K, L, M - 356 γ angular correlations in Pt¹⁹⁶ have been performed using the apparatus adopting a Si(Li) crystal, as described in Section II. The electron

spectrum of Au¹⁹⁶ taken with a 14 mm ϕ \times 3 mm thick Si(Li) detector, singles and coincident with 333 + 356 γ , are presented in Fig. 3. Here the L peak involves all the L-subshell electrons and the M peak involves M, and higher-shell electrons. The obtained correlation functions are illustrated in Fig. 4, and uncorrected correlation functions are tabulated in Table I.

Although this data is too preliminary to deduce a quantitative argument, they allow one to make qualitative discussions.

The $A_4^{(i)}$ (e- γ) coefficient itself does not give any information on the parameters q and λ , since it depends only on the E2 component. However, from the relations

$$b_4^{(i)}(\text{E2}, 356) = \frac{A_4^{(i)}(333 \gamma - 356 e)}{A_4(333 \gamma - 356 \gamma)}$$

and

$$b_4^{(i)}(\text{E2}, 333) = \frac{1 + p_i^2 + q_i^2}{1 + \rho^2} \frac{A_4^{(i)}(333 e - 356 \gamma)}{A_4(333 \gamma - 356 \gamma)} \approx \frac{A_4^{(i)}(333 e - 356 \gamma)}{A_4(333 \gamma - 356 \gamma)}$$

we can determine $b_4^{(i)}(\text{E2})$ particle parameters. It is worth noting that the determination of $b_4^{(i)}(\text{E2})$ parameter is a very sensitive way to determine $b_2^{(i)}(\text{E2})$ parameter, because these two quantities are related by an equation

$$\frac{b_4^{(i)}(\text{E2}) - 1}{b_2^{(i)}(\text{E2}) - 1} = -2.5$$

and furthermore A_4 is less affected by the admixture of dipole or monopole component. The present data shows that the 333 γ - 356 K and 333 K - 356 γ angular correlations have small negative A_4 coefficients. This fact implies the $b_2^K(\text{E2})$ for 333 keV or 356 keV is slightly larger than 1.4. In Fig. 5

are shown theoretical curves of E2 particle parameters calculated by Biedenharn and Rose¹⁶ (point nucleus) and by Band et al.¹⁵ (finite-size nucleus, screening). The experimental tendency seems to agree qualitatively with the theoretical predictions. All the angular correlations involving L and M conversions reveal considerable positive A_4 coefficients. This fact shows that $b_4^L(E2)$ and $b_4^M(E2)$ have positive values. As for L conversion δ this fact seems to agree with theoretical prediction. It is seen that M conversion electrons have nearly the same particle parameters as L conversion electrons.

The angular correlation of L and M electrons is fairly different from that of K electrons because of the difference not in $b_2(E2)$ but in $b_4(E2)$, as demonstrated here experimentally and illustrated in Fig. 5 theoretically. Recently Sakai, Yamazaki and Ejiri¹⁷ reported anomalous experimental K/L ratios of E2 transitions emitted after (p,2n) reactions and made arguments that the observed anomalies might be attributed partly to angular distribution of gamma rays and consequently to different behavior of K and L electrons due to the difference in particle parameter. The present result shows that this phenomena is supposed to arise not only from the $P_2(\cos \theta)$ term but also $P_4(\cos \theta)$ term of angular distribution.

Now we have two quantities, $A_2^K(e-\gamma)$ and $A_2^L(e-\gamma)$, which are independently correlated to the nuclear-structure parameters q and λ . Although at the moment there is no numerical basis for analyzing this data, they will be helpful in the near future.

The current project described here is in progress with the collaboration of J. M. Hollander.

V. SPECIAL PROBLEM

Because of different angular correlations of gamma rays and conversion electrons the conversion coefficient of the second transition with respect to the first transition has an angular dependence:

$$\alpha^{(i)}(\theta) = \bar{\alpha}^{(i)} \frac{\sum_{\nu} A_{\nu}^{(i)} P_{\nu}(\cos \theta)}{\sum_{\nu} A_{\nu} P_{\nu}(\cos \theta)}, \quad (1)$$

where $\bar{\alpha}^{(i)}$ is the ordinary conversion coefficient observed when coincidence is not taken. The deviation depends not only on the nature of the second transition but on what kind of emission is involved in the first transition. Anyway, deviations of this type can be accounted for completely in terms of particle parameters. Now we may raise a question as to whether there is anomaly of conversion coefficients which arises from the dynamical rearrangements of atomic configuration following the preceding transition. The following discussion is concerned with this problem.

Let us suppose a simple cascade of two gamma transitions. In Fig. 6 are illustrated intermediate atomic states following gamma rays and conversion electrons. For simplicity higher shells and the Auger effects are neglected. K conversion process produces a K electron hole, which proceeds to L_{II} and L_{III} electron holes with the emission of K_{α_2} and K_{α_1} X-rays, respectively. Similarly, L subshell conversion process produces an L subshell electron hole, while gamma rays produce no change in the inner atomic configuration. Then, the occupation probability of the "i" electron orbit has a time-dependent form.

$$\xi_i(t) = 1 - a_i e^{-t/\tau_i},$$

where t = time elapsed after the first transition occurs,

τ_i = mean life time of the "i" electron hole,

a_i = vacancy probability of the "i" orbit at $t=0$.

The values of $a_{L_{I,II,III}}$ for various experimental conditions are presented in Table II.

Unless the mean life time of the intermediate nuclear state, τ_N , is too long compared with τ_i , reduction of the emission probability of conversion electrons should occur due to the lack of electrons in the shell in question. The conversion coefficient becomes anomalous as given by

$$\alpha^{(i)}(\theta) = \left[1 - a_i \frac{\tau_i}{\tau_N + \tau_i} \right] \alpha^{(i)}(\theta, \text{static})$$

where $\alpha^{(i)}(\theta, \text{static})$ means the conversion coefficient given by Eq. (1), which includes the angular correlation effect. The anomaly factor depends on a_i and τ_i/τ_N , as illustrated in Fig. 7.

It is well known that τ_K is shorter than 10^{-16} sec for nuclei of $A \gtrsim 50$, whereas τ_N is longer than 10^{-14} sec. Therefore there is no possibility of such an anomaly for K conversion electrons. On the other hand, τ_L can be so close to τ_N of a very fast transition that such an anomaly may be observed in some particular cases. There is no reliable experimental data on $\tau_{L_{I,II,III}}$, because it is too long to permit measurements of natural width of L X-ray lines.¹⁸ If we neglect the Auger process, which may not be valid for medium-weight nuclei, the single-particle approximation gives

$$\tau_i = \frac{1}{f_i} \cdot \frac{Z^2}{E_L^3} \times 10^{-6} \text{ sec,}$$

where E_L is the energy of L X-rays in eV, and f_i , defined by

$$f_i \equiv \frac{\sum_j |\langle j | \vec{r} | i \rangle|^2}{(a_0/Z)^2},$$

is a quantity of order of 1. For example, for $Z = 50$, $f_i \tau_i$ is 4×10^{-14} sec.

A possible experimental method to detect the anomaly is, for example, to compare $L_{I,II,III}/K$ ratios in coincidence with the preceding conversion electrons or K X-rays or gamma rays. In order to discriminate the anomaly, the complete knowledge of angular correlation functions involving conversion electrons is of essential importance.

It is worth pointing out that if we have reliable knowledge on τ_i this method will be a powerful tool to measure a very fast nuclear life time of order of 10^{-13} or 10^{-14} sec. The situation is similar to the measurement of monoenergetic positron line which is as well related to the lifetime of an electron hole. Actually, Wiener et al.¹⁹ determined the nuclear life time of the 1/20-keV transition in Pb^{206} to be 2.1×10^{-14} sec by measuring the intensity of the monoenergetic positron line which was produced as a consequence of the capture of an electron of internal pair formation into the K electron hole following K electron capture. In this case, $\tau_K = 1.15 \times 10^{-17}$ and τ_K/τ_N is as small as 10^{-3} . Comparing with this, we see that the present method has a shortcoming in that the quantity to be measured is proportional to $1 - \tau_i/\tau_N$ so that the small value of τ_i/τ_N is difficult to detect, whereas in the latter the quantity is proportional to τ_i/τ_N .

The author would like to appreciate the discussions with Drs. J. M. Hollander, T. Novakov, J. O. Rasmussen, and M. Sakai.

Table I. Preliminary data of angular correlations involving K, L and M conversion electrons in Pt¹⁹⁶.

Cascade	A_2'	A_4'
333 γ - 356 K	0.065 ± 0.005	-0.023 ± 0.006
333 γ - 356 L	0.049 ± 0.009	0.051 ± 0.010
333 γ - 356 M	0.046 ± 0.016	0.054 ± 0.019
333 K - 356 γ	-0.035 ± 0.005	-0.025 ± 0.006
333 L - 356 γ	-0.021 ± 0.008	0.047 ± 0.010
333 M - 356 γ	-0.032 ± 0.012	0.083 ± 0.016

Table II. Initial vacancy probabilities a_i for L subshells.

Preceding emission	a_{L_I}	$a_{L_{II}}$	$a_{L_{III}}$
K conversion	0	$\eta(K\alpha_2)/2^*$	$\eta(K\alpha_1)/4^*$
$K\alpha_1$ X-ray	0	0	1/4
$K\alpha_2$ X-ray	0	1/2	0
L_I conversion	1/2	0	0
L_{II} conversion	0	1/2	0
L_{III} conversion	0	0	1/4

* $\eta(K\alpha_1)$ stands for the branching ratio of $K\alpha_1$ X-ray.

FOOTNOTES AND REFERENCES

*For the International Conference on Internal Conversion Process, Nashville, Tennessee, May 10-13, 1965.

1. For instance, the 7-(E2) 5-(E1) 4+ sequence was demonstrated by H. Ikegami, Phys. Rev. 120, 2185 (1960); H. Ikegami and T. Udagawa, Phys. Rev. 124, 1518 (1961).
2. M. Sakai, H. Ikegami, T. Yamazaki and K. Saito, Nucl. Phys. 65, 177 (1965).
3. E. L. Church and J. Weneser, Phys. Rev. 104, 1382 (1956).
4. T. R. Gerholm, B.-G. Pettersson, B. van Nooijen and Z. Grabowski, Nucl. Phys. 24, 177 (1961); B. G. Pettersson, T. R. Gerholm, Z. Grabowski and B. van Nooijen, Nucl. Phys. 24, 196 (1961); Z. Grabowski, B.-G. Pettersson, T. R. Gerholm and J. E. Thun, Nucl. Phys. 24, 251 (1961). The experimental data should be reanalyzed because of the reversed sign of b_2 .
5. J. E. Thun, S. Törnkvist, F. Falk, H. Snellman, and F. Kropff, Phys. Letters 8, 326 (1964).
6. C. J. Herrlander and R. L. Graham, Nucl. Phys. 58, 544 (1964).
7. E. L. Church, M. E. Rose and J. Weneser, Phys. Rev. 109, 1299 (1958).
8. T. R. Gerholm and B.-G. Pettersson, Phys. Rev. 110, 1119 (1958); T. R. Gerholm, M. S. El-Nesr, E. Bashady, and B.-G. Pettersson, Arkiv Fysik 21, 241 (1962). The experimental data should be reanalyzed because of the reversed sign of b_2 .
9. On Os¹⁸⁸ and Os¹⁹⁰: T. Yamazaki, Nucl. Phys. 44, 353 (1963); 61, 497 (1965).

10. On Pt¹⁹⁶: H. Ikegami, K. Sugiyama, T. Yamazaki and M. Sakai, (to be published).
11. On Hg¹⁹⁸: M. Sakai, M. Nozawa, H. Ikegami and T. Yamazaki, Nucl. Phys. 53, 529 (1964).
12. D. K. Butt and B. C. Dutta, Nucl. Phys. 39, 517 (1962).
13. T. R. Gerholm, R. Othaz and M. S. El-Nesr, Arkiv Fysik 21, 253 (1962).
14. M. Sakai, H. Ikegami and T. Yamazaki, Nucl. Instr. Methods 9, 107 (1960); 25, 328 (1964).
15. I. M. Band, M. A. Listengarten, L. A. Sliv, and J. E. Thun, "Alpha-, Beta- and Gamma-Ray Spectroscopy," ed. by K. Siegbahn, (North-Holland Publishing Co., Amsterdam, 1965) p. 1683.
16. L. C. Biedenharn and M. E. Rose, Rev. Mod. Phys. 25, 746 (1953).
17. M. Sakai, T. Yamazaki, and H. Ejiri; INS-Report 77 (Institute for Nuclear Study, University of Tokyo, March, 1965); contribution to the present conference.
18. G. T. Ewan and R. L. Graham, "Alpha-, Beta-and Gamma-Ray Spectroscopy," ed. by K. Siegbahn, (North-Holland Publishing Co., Amsterdam, 1965) p. 951.
19. R. Wiener, C. Chasman, P. Harihar and C. S. Wu, Phys. Rev. 130, 1069 (1963).

FIGURE CAPTIONS

- Fig. 1. Schematic view of the electron-electron spectrogoniometer constructed by Sakai, Ikegami and Yamazaki.
- Fig. 2. Schematic view of the electron-gamma angular correlation apparatus using solid-state detectors, which is being made by Yamazaki and Hollander. When high resolution is needed, the Si(Li) detector is replaced by the Berkeley 50-cm radius $\pi\sqrt{2}$ iron-free spectrometer.
- Fig. 3. Conversion electron spectra of Au^{196} taken with a $14 \text{ mm}\phi \times 3 \text{ mm}$ thick Si(Li) detector.
- Fig. 4. An example of various $e^- - \gamma$ angular correlations on Pt^{196} .
- Fig. 5. Theoretical curves of $b_2(E2)$ and $b_4(E2)$ parameters for K, L_{I} and L_{II} conversion electrons, calculated by Biedenharn and Rose and by Band et al.
- Fig. 6. Illustration of a decay sequence involving intermediated atomic states.
- Fig. 7. Anomaly factor versus π_i/τ_i in the case of $\alpha_i = 0.5$.

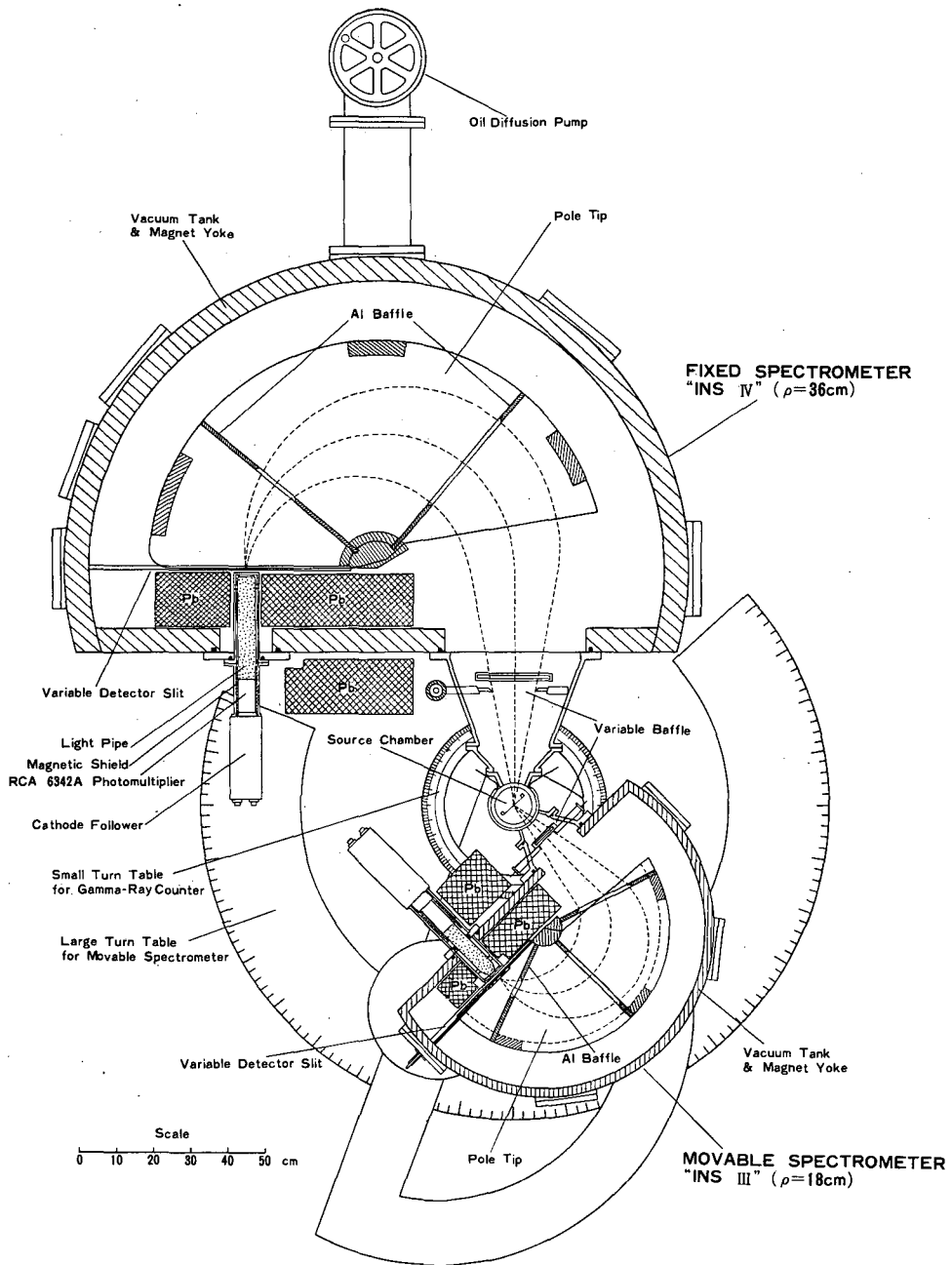

Fig. 1. Schematic diagram of the beta-ray spectrogoniometer.

MUB-6018

Fig. 1

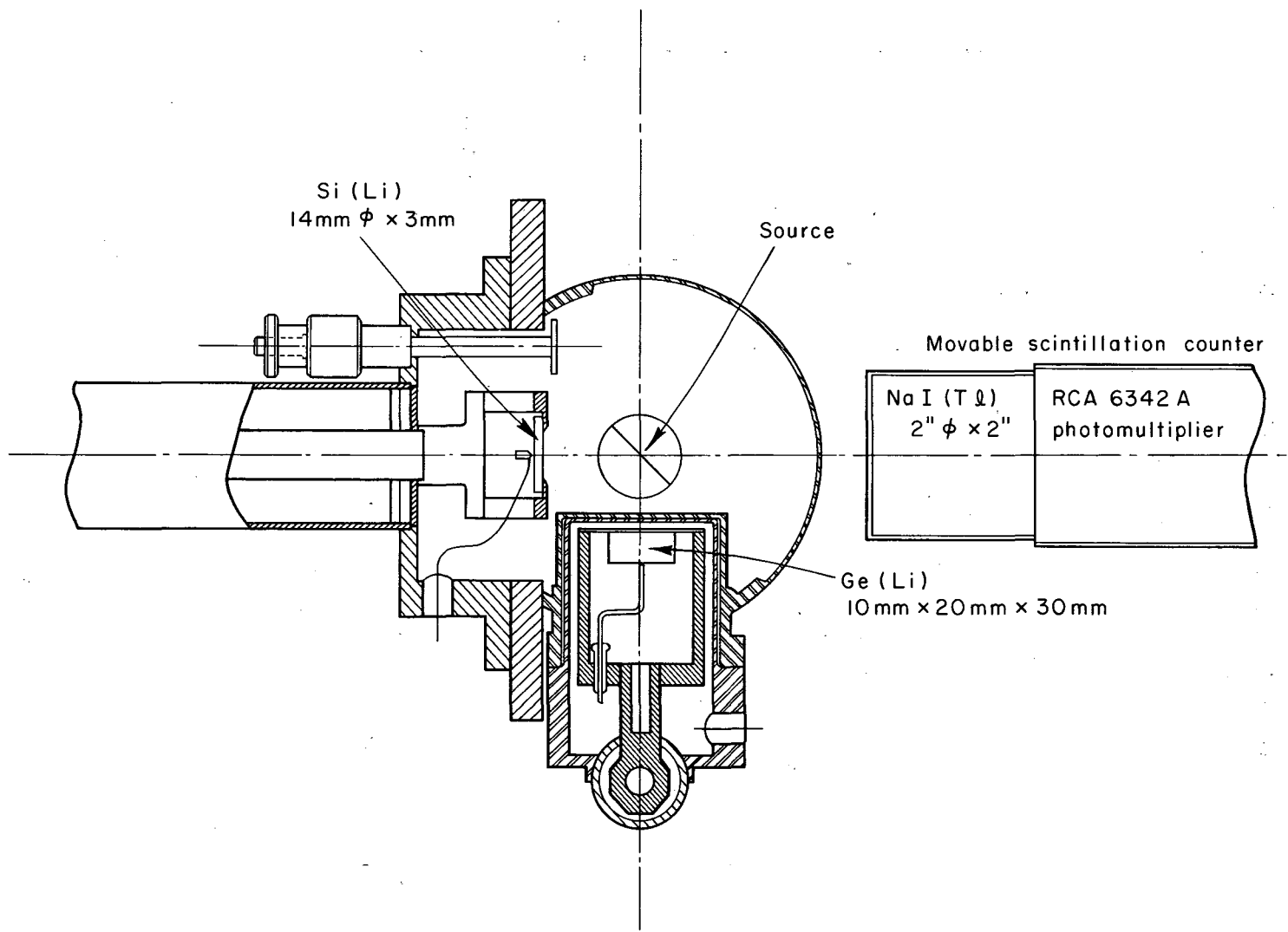
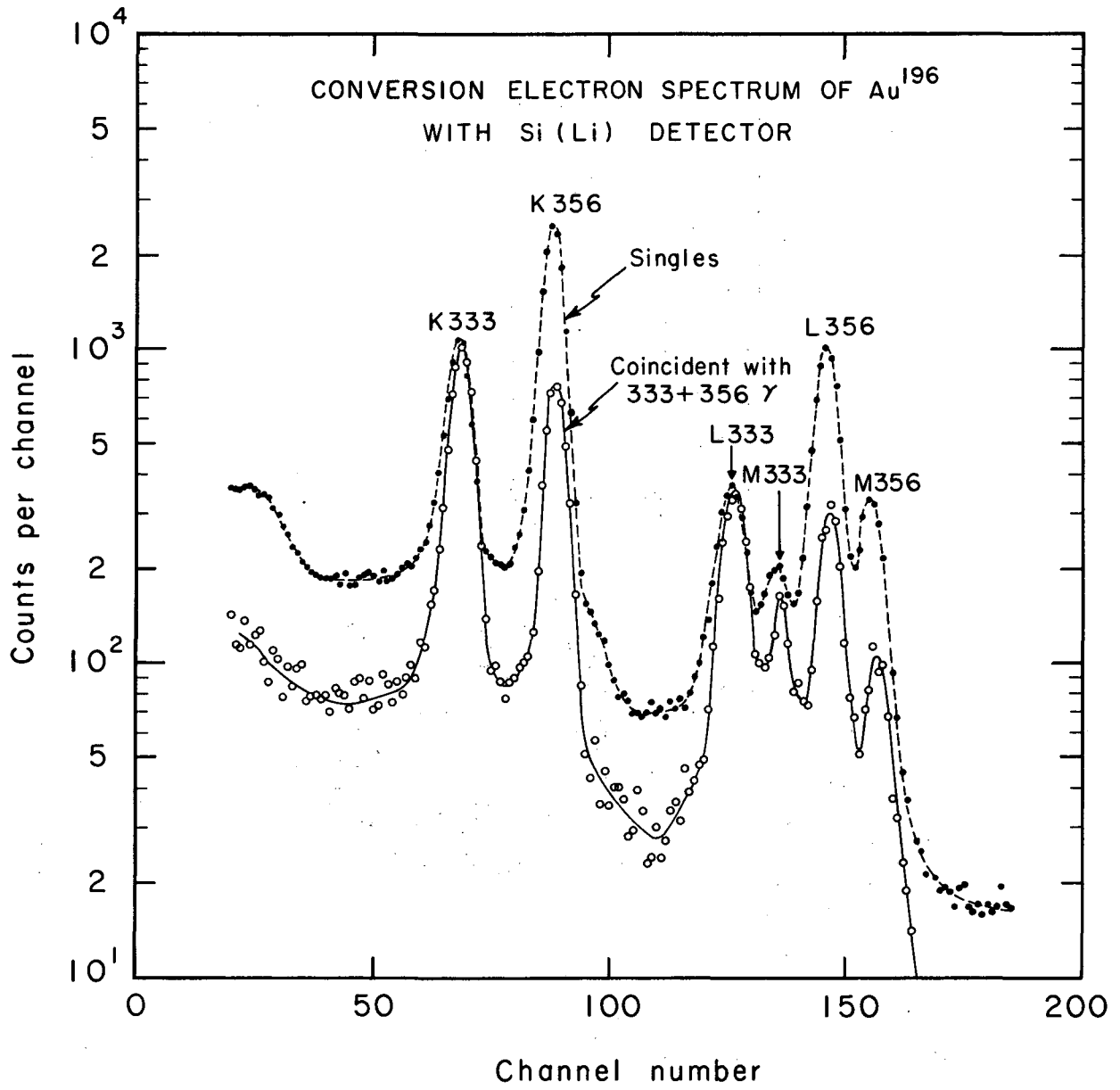
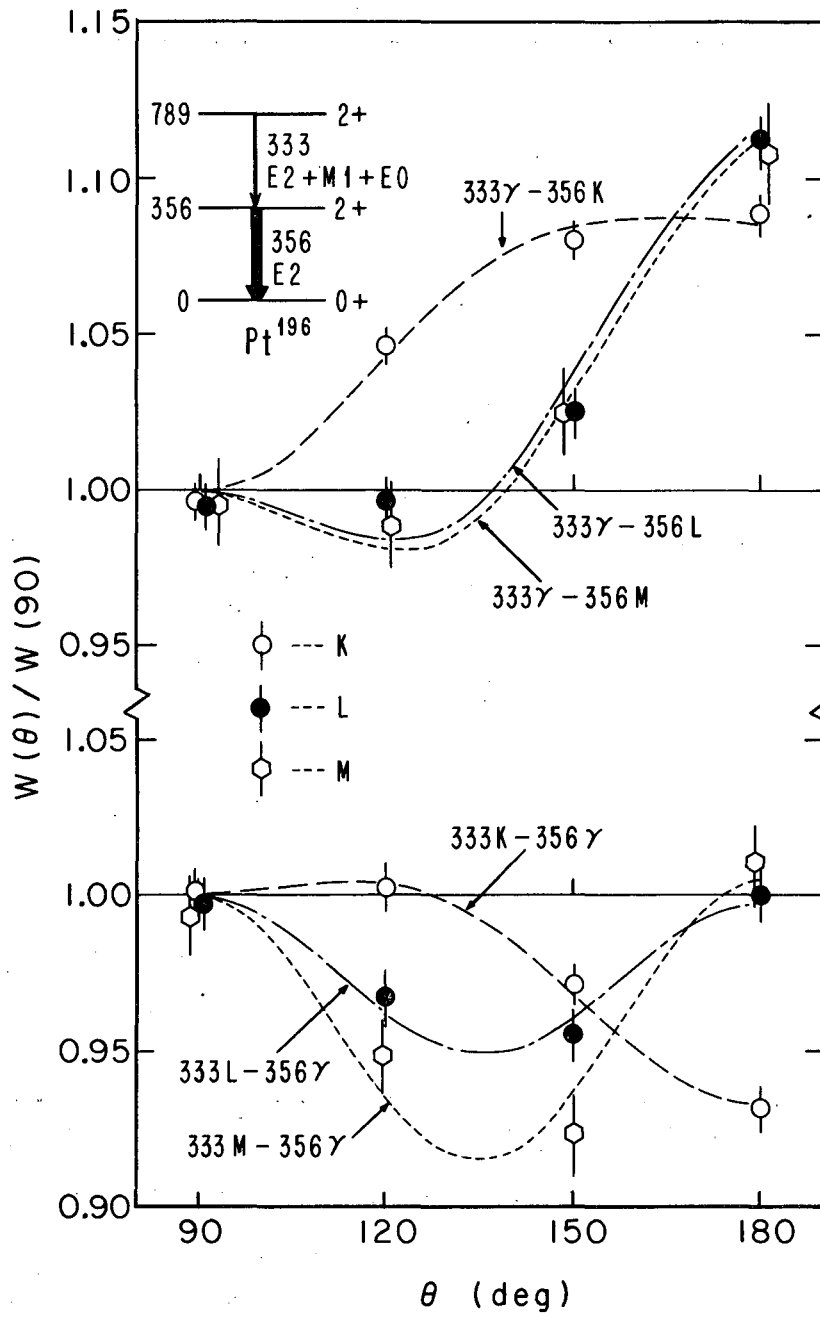

Fig. 2



MUB-5974

Fig. 3



MUB-6046

Fig. 4

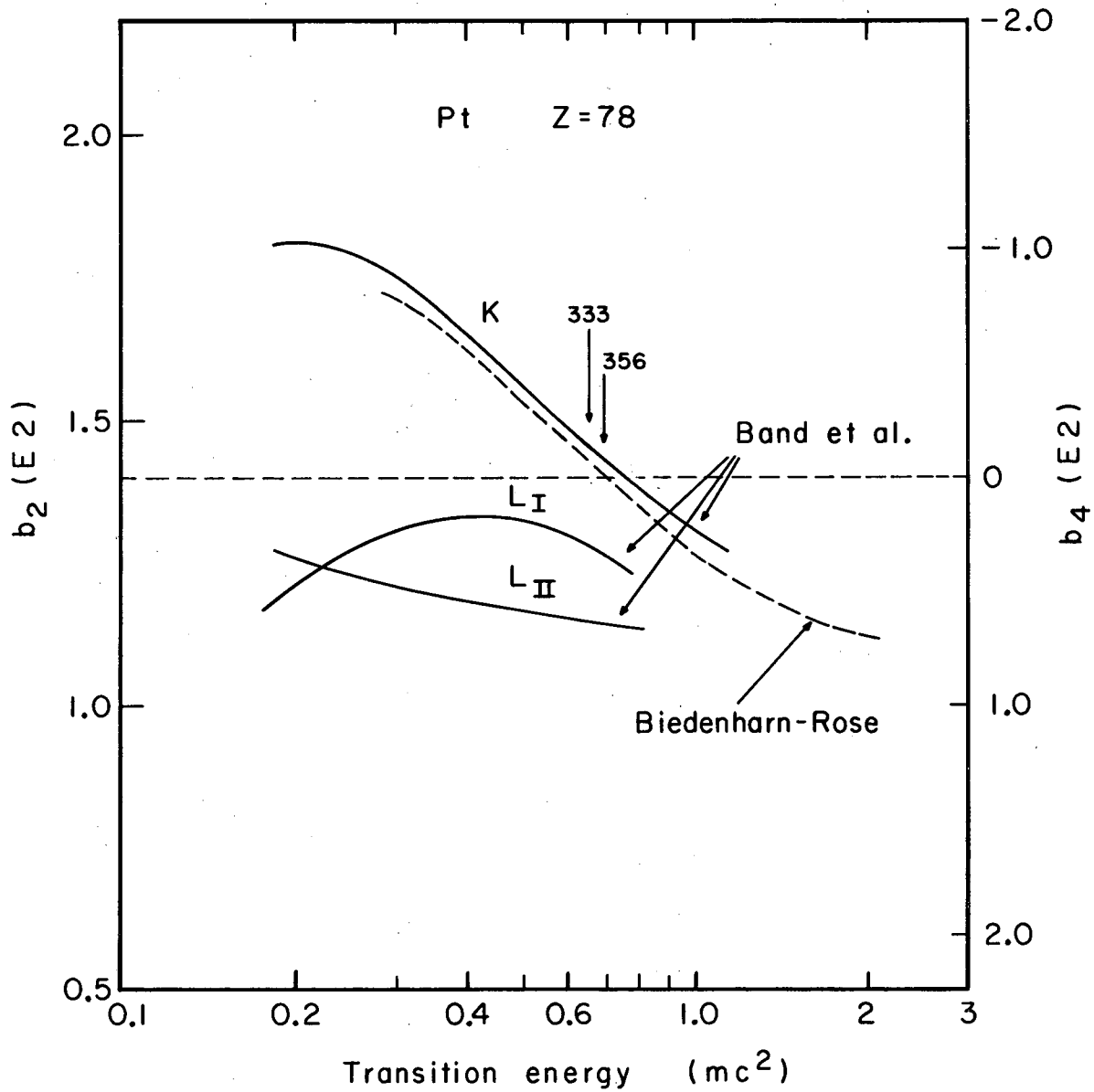

MUB-6045

Fig. 5

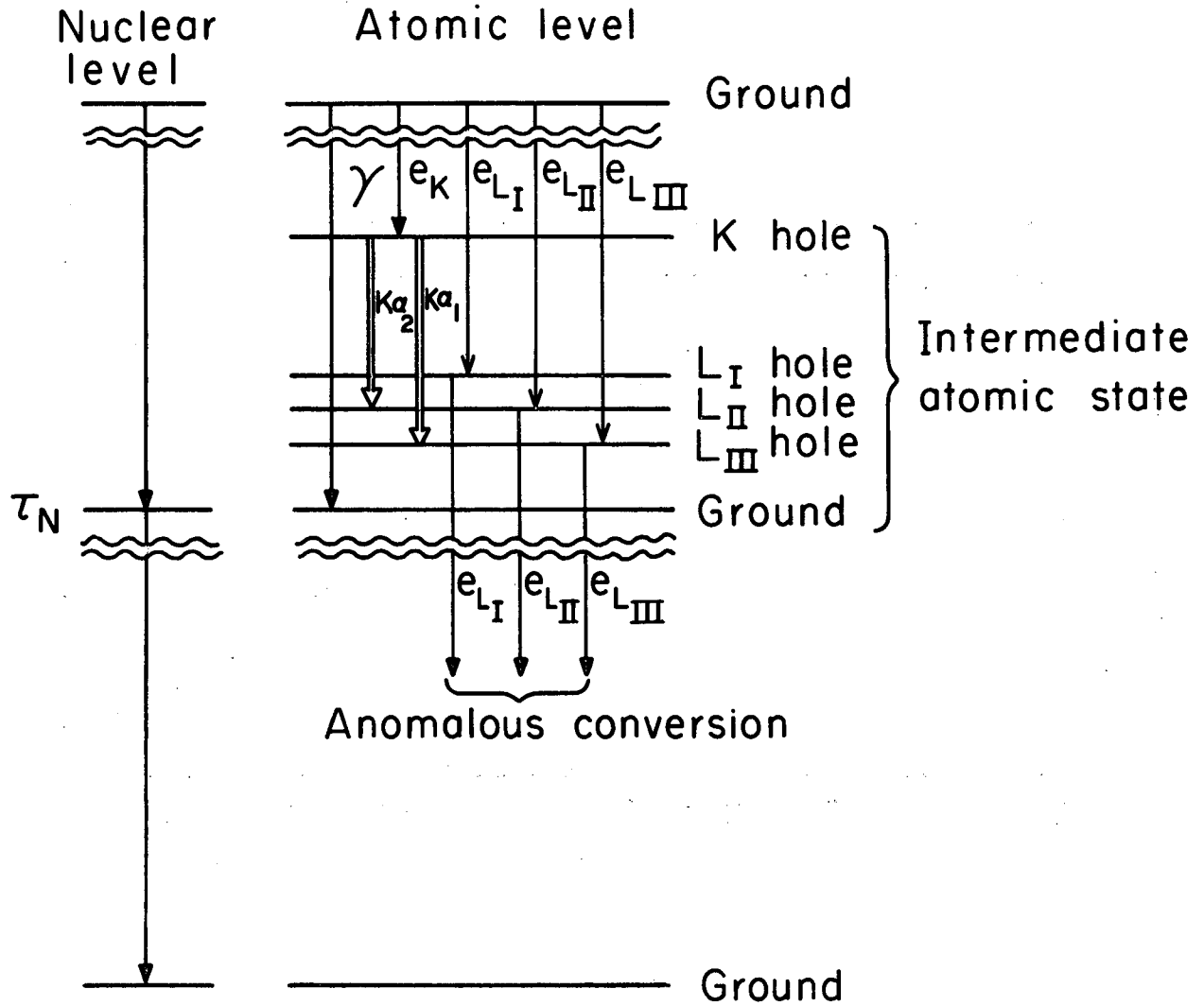

MUB-6299

Fig. 6

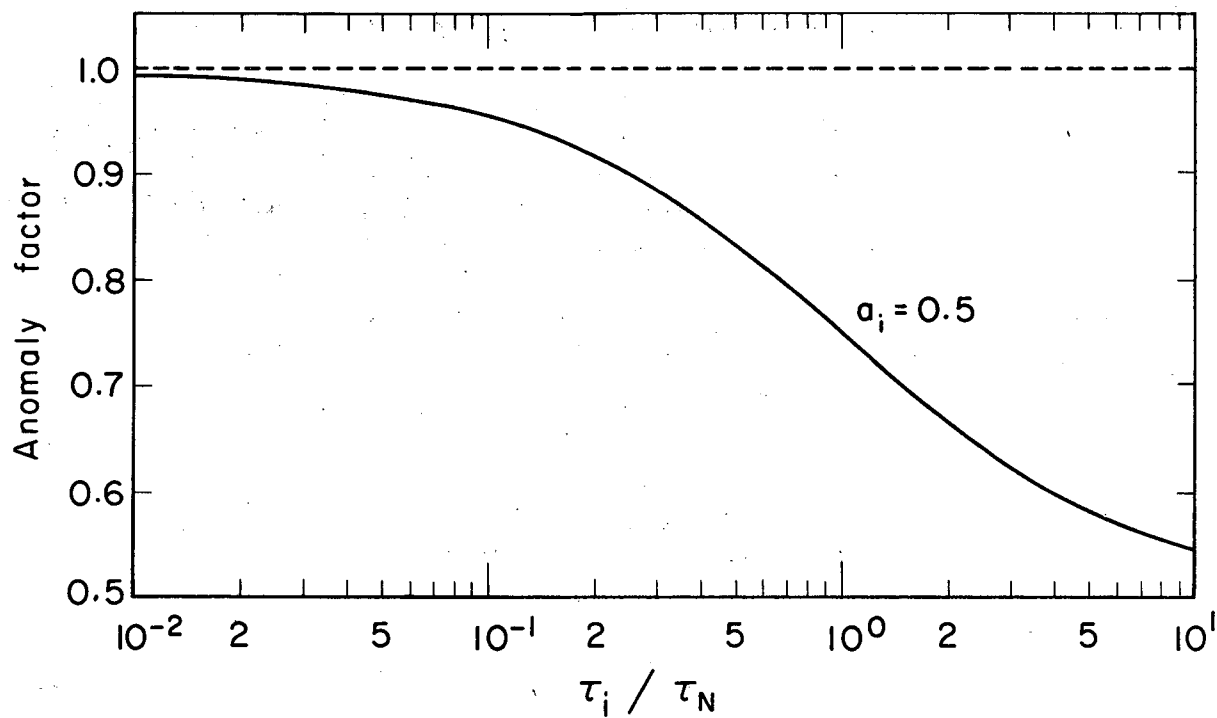

MUB-6300

Fig. 7

This report was prepared as an account of Government sponsored work. Neither the United States, nor the Commission, nor any person acting on behalf of the Commission:

- A. Makes any warranty or representation, expressed or implied, with respect to the accuracy, completeness, or usefulness of the information contained in this report, or that the use of any information, apparatus, method, or process disclosed in this report may not infringe privately owned rights; or
- B. Assumes any liabilities with respect to the use of, or for damages resulting from the use of any information, apparatus, method, or process disclosed in this report.

As used in the above, "person acting on behalf of the Commission" includes any employee or contractor of the Commission, or employee of such contractor, to the extent that such employee or contractor of the Commission, or employee of such contractor prepares, disseminates, or provides access to, any information pursuant to his employment or contract with the Commission, or his employment with such contractor.

[The page contains extremely faint, illegible text, likely bleed-through from the reverse side of the document. The text is too light to transcribe accurately.]

