

Lawrence Berkeley National Laboratory

LBL Publications

Title

Gas-Filled Panel High-Performance Thermal Insulation

Permalink

<https://escholarship.org/uc/item/6cf6z1sx>

Authors

Griffith, B.T.

Arasteh, D.

Selkowitz, S.E.

Publication Date

1991-04-01



Lawrence Berkeley Laboratory

UNIVERSITY OF CALIFORNIA

APPLIED SCIENCE DIVISION

Submitted to *Insulation Materials: Testing and Applications*

Gas-Filled Panel High-Performance Thermal Insulation

B.T. Griffith, D. Arasteh, and S. Selkowitz

April 1991

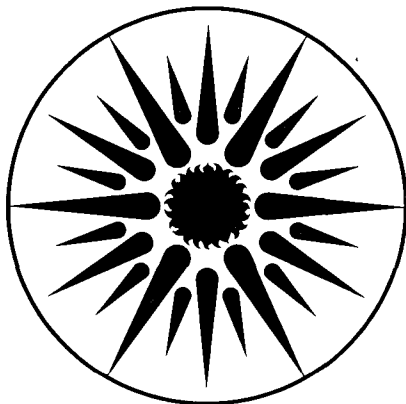

**APPLIED SCIENCE
DIVISION**

LOAN COPY
Circulates
for 4 weeks
Bldg. 50 Library.
Copy 2

LBL-30160

DISCLAIMER

This document was prepared as an account of work sponsored by the United States Government. While this document is believed to contain correct information, neither the United States Government nor any agency thereof, nor the Regents of the University of California, nor any of their employees, makes any warranty, express or implied, or assumes any legal responsibility for the accuracy, completeness, or usefulness of any information, apparatus, product, or process disclosed, or represents that its use would not infringe privately owned rights. Reference herein to any specific commercial product, process, or service by its trade name, trademark, manufacturer, or otherwise, does not necessarily constitute or imply its endorsement, recommendation, or favoring by the United States Government or any agency thereof, or the Regents of the University of California. The views and opinions of authors expressed herein do not necessarily state or reflect those of the United States Government or any agency thereof or the Regents of the University of California.

To be published in *Insulation Materials: Testing and Applications*, Vol. 2, ASTM STP 1116, for the 2nd Symposium on Insulation Materials: Testing and Applications, October 10-12, 1991, Gatlinburg, TN. American Society for Testing Materials.

GAS-FILLED PANEL HIGH-PERFORMANCE THERMAL INSULATION

Brent T. Griffith, Dariush Arasteh, and Stephen Selkowitz

Applied Science Division
Lawrence Berkeley Laboratory
University of California
1 Cyclotron Road
Berkeley, California 94720

April 1991

The research reported here was funded, in part, by the California Institute for Energy Efficiency (CIEE), a research unit of the University of California. Publication of research results does not imply CIEE endorsement of or agreement with these findings, nor that of any CIEE sponsor. This work was also supported by the Assistant Secretary for Conservation and Renewable Energy, Office of Building Technologies, Building Systems and Materials Division of the U.S. Department of Energy under Contract No. DE-AC03-76SF00098.

Brent T. Griffith, Dariush Arasteh, and Stephen Selkowitz

GAS-FILLED PANEL HIGH-PERFORMANCE THERMAL INSULATION

ABSTRACT

This paper introduces a new high performance non-CFC based insulating material with primary applications for refrigerator/freezer and building walls. Characteristics of these gas-filled panels, projected and experimental thermal performance levels, cost estimates, and manufacturing/installation issues for this material are discussed. Independent testing of prototypes has yielded R-values of 36 m-K/W (5.2 hr-ft²-F/Btu-in) for air filled panels, 49.3 m-K/W (7.1 hr-ft²-F/Btu-in) for argon filled panels, and 86.8 m-K/W (12.5 hr-ft²-F/Btu-in) for krypton filled panels. Target R-values values are 36 m-K/W (5.2 hr-ft²-F/Btu-in), 55 m-K/W (8 hr-ft²-F/Btu-in), and 105 m-K/W (15 hr-ft²-F/Btu-in) for air, argon, and krypton filled panels, respectively. Manufacturing costs depend strongly on gas-fill and structural requirements and are estimated at 42 to 850 \$/m³ (0.10 to 2.00 \$/ft²-in). This insulation system can be fabricated using commercially available materials and equipment.

KEYWORDS: non-CFC insulation, thermal insulation, multilayer, argon, krypton, low emissivity, gas-filled

INTRODUCTION AND MATERIAL DESCRIPTION

Recent research efforts at Lawrence Berkeley Laboratory's Windows and Daylighting Group have focused on the development of low to moderate cost, highly insulating gas-filled panels (GFPs). Development of this and other high-performance insulating materials is motivated by the need to replace CFC blown foam insulation (currently the highest performance insulation available) while also building more energy efficient buildings and appliances.

Gas-filled panels (GFPs), an outgrowth of superinsulated window technology [1], insulate by encapsulating a low thermal conductivity gas or gas mixture at atmospheric pressure within sealed panels. Low emissivity baffles suppress convective and radiative heat transfer. A schematic of one possible GFP is given in Figure 1. However, unlike foams or fibrous insulations, GFPs are not a homogeneous material; rather they are an assembly of specialized components. The wide range of potential applications (appliances, manufactured housing, site built buildings, refrigerated transport, etc.) lead to several alternative embodiments. GFPs are as much a new approach to insulating as they are a new insulating material. While the materials used for prototype GFPs are commercially available, fine tuning of components may be necessary for a commercial product. This

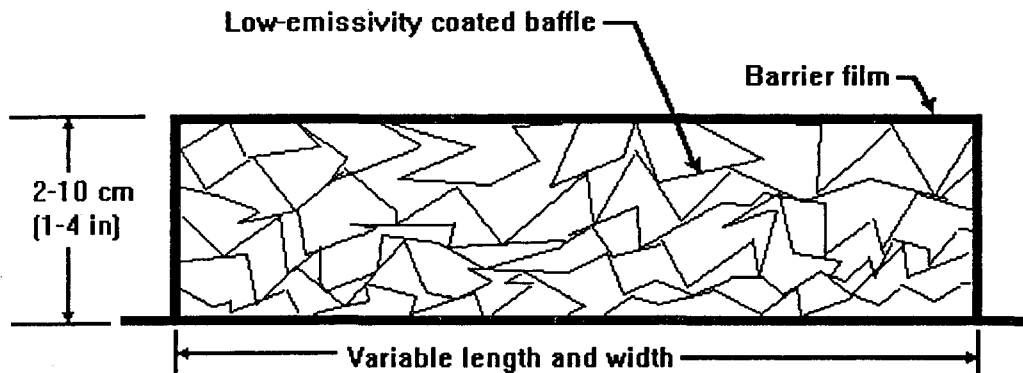

Figure 1: Gas-filled panel schematic cross-section. This figure shows a random orientation of baffle layers; other configurations are possible.

material is the subject of a patent application by Lawrence Berkeley Laboratory. With the exception of a description of the panels that were independently tested, specifics of developed panel designs and materials are omitted for patent reasons.

GFPs utilize interior baffles to minimize heat transfer and to provide structure. Convection suppression is achieved by constructing baffles from multiple non-permeable layers. These layers can be either flexible or structural and can take on various geometric forms. Baffles are constructed to create interior cavities optimized in thickness (direction of heat flow) for the specific gas and application. Typical thicknesses range from 5 to 12 mm (0.2 - 0.5 in.). Baffle surfaces are pre-coated with a low emissivity surface, typically a thin layer of aluminum 200 to 500 angstroms thick, in order to minimize radiative heat transfer across the cavities. To limit solid conduction, baffles are constructed of low conductivity materials such as thin plastics or paper and are arranged to create long solid conduction paths. For most GFP embodiments, the baffle is self-supporting and helps define the shape of the panel. The baffles can be made with stiff materials to create a strong supportive structure or they can be made flexible and resilient. Depending on the baffle, a continuous variation between structural panels and merely self-supporting panels is possible. While refrigerator and freezer applications will require structural panels, building wall cavity applications are best served with non supportive panels which can be collapsed for transport.

Given an effective baffle, solid conduction through the gas is the only remaining means of heat transfer. Air is a good insulator and low-cost air GFPs are expected to have many uses in building applications. However, other gases, such as argon (Ar), carbon-dioxide (CO₂), sulfur hexafluoride (SF₆), krypton (Kr), and xenon (Xe) have significantly lower thermal conductivities. These gases are all non-toxic and

either non-reactive or inert. We focus on the use of argon and krypton in GFPs since these gases are inert, have the proper thermophysical properties, and are readily available from the atmosphere. While xenon offers the potential for superior thermal performance, it is currently too costly for such applications. It should be noted, however, that as air separation techniques have improved over the past two decades, the prices of specialty gasses have dropped.

External barriers which serve to contain both the baffle and gas are the final critical component of GFPs. High barrier, multilayer polymer films developed for the food packaging industry have been used successfully for prototypes. Such films, which use gas barrier resins such as ethylene vinyl alcohol (EVOH) and polyvinyl alcohol (PVOH), are durable, puncture resistant, have very low gas transmission rates, and are heat sealable. Other barrier materials under investigation include aluminum and silicon oxide coatings.

Panel geometries will vary depending on the intended application. In order to avoid changing existing foam-in-place manufacturing methods, refrigerators and freezers will initially use thin (approximately 25 mm (1 in)) modular krypton filled panels in composite with a non-CFC foam. For building applications, the panels will initially fit into stud wall cavities with sealing flanges extending over studs for stapling in a manner similar to fiberglass insulation. Multiple layers of individual panels can be used for greater flexibility in sizing thickness and for greater insurance against punctures. Panel shapes, sizes, and stiffness can be adjusted for numerous other applications including HVAC insulation, hot water heater insulations, swimming pool and spa covers, refrigerated transport walls, and airplane walls.

PROJECTED PERFORMANCE AND COST

The theoretical performance levels for GFPs are based on eliminating convection, infrared radiation and solid conduction, with only conductive heat transfer through the still gas remaining. Still gas conductivities, at atmospheric pressure and 273 K (32 F), are 0.0241 W/m-K (0.0139 Btu/hr-ft-F) for air, 0.0164 W/m-K (0.0095 Btu/hr-ft-F) for argon, and 0.0087 W/m-K (0.0050 Btu/hr-ft-F) for krypton [2]. Table 1 presents theoretical maximum R-values based on these values and conductivities at 300 K (80 F). A temperature of 273 K (32 F) is representative of the temperature of a typical GFP in a refrigerator/freezer or building wall while the higher temperature of 300K (80 F) is close to the temperature of GFPs in HVAC and hot water applications as well as the mean temperature under ASTM C 518 test conditions. While convection may be effectively eliminated, heat transfer by solid conduction and minimal radiation will degrade these values slightly in real panels. Values given for projected performance are estimates based on testing and computer simulations.

Cost estimates for air, argon, and krypton GFPs shown in Table 2 are based on prices of material components and the assumption that roughly 80% of the cost is materials. This assumption is typical for the high throughput assembly of plastic products from preprocessed, roll stock materials. These cost numbers are preliminary and do not reflect a detailed examination of manufacturing and marketing issues as well as specific material's economies. For comparison, cost data

for fiberglass and CFC foams is also given [3]. Costs given for all products are costs for the assembler to produce the materials. Note that costs given in the literature often vary substantially depending on the degree of indirect overhead costs incorporated into the "manufacturers costs." GFPs with R-values anywhere in between those given for air and those given for krypton can be manufactured using the appropriate mixtures of air, argon, and krypton. Both performance and cost are roughly linear with gas composition.

Table 1 -- GFP Theoretical and Projected Thermal Performance
R-values in m-K/W (hr-ft²-F/Btu-in)

	Theoretical R-value		Projected R-value
	273 K (32 F)	300 K (80 F)	273 K (32 F)
Air GFP	41 (6.0)	38 (5.5)	36 (5.2)
Argon GFP	61 (8.8)	56 (8.1)	55 (8)
Krypton GFP	115 (16.6)	106 (15.3)	105 (15)

Table 2 -- Performance and Manufacturing Cost Estimates

	R-value m-K/W (hr-ft ² -F/Btu-in)	Estimated Costs	
		\$/m ³ (\$/ft ² -in)	\$/m ² -R (\$/ft ² -R)
Fiberglass	24.3 (3.5)	17-21 (0.04-0.05)	0.60-0.90 (0.01-0.015)
CFC Blown Foam	50.7 (7.3)	85-210 (0.20-0.50)	1.8-4.3 (0.03-0.07)
Air GFP	36 (5.2)	42-85 (0.10-0.20)	1.2-2.4 (0.02-0.04)
Argon GFP	55 (8)	127-212 (0.30-0.50)	2.4-3.7 (0.04-0.06)
Krypton GFP	105 (15)	635-850 (1.50-2.00)	6.1-7.9 (0.10-0.13)

PROTOTYPE EVALUATION

During 1990, over one hundred prototypes were built and their thermal performance evaluated using an infrared imaging system. Prototype samples, typically 200 or 300 mm square (8 or 12 in. square), were placed in a rigid foam board of a known resistance. A temperature difference was generated across the insulation by placing the sample between ambient temperature and a cold chamber. The infrared imaging system was then used to compare warm side surface temperatures of the prototype to that of the surrounding foam. This setup is shown schematically in Figure 2. Warm side temperatures are directly correlated with thermal resistances: the warmer the room side surface temperature, the better the insulator. Such side by side testing allows for quick, visual, and accurate evaluation of prototype samples. A versatile post-processing system provides quantitative information on the prototypes. Figures 3, 4, and 5 are samples of this post-processed data. These figures show that air filled panels perform as well as rigid styrene foam board (assumed at $R35 \text{ m-K/W}$ ($R5 \text{ hr-ft}^2\text{-F/Btu-in}$)), argon panels perform slightly better than CFC blown polyiso-cyanurate foam board (assumed at $R50 \text{ m-K/W}$ ($R7.2 \text{ hr-ft}^2\text{-F/Btu-in}$)), and krypton filled panels perform significantly better than CFC blown polyiso-cyanurate foam board. The infrared thermograms of Figures 3,4, and 5 generally show that temperatures are roughly the same for different areas. This, in itself, is useful information.

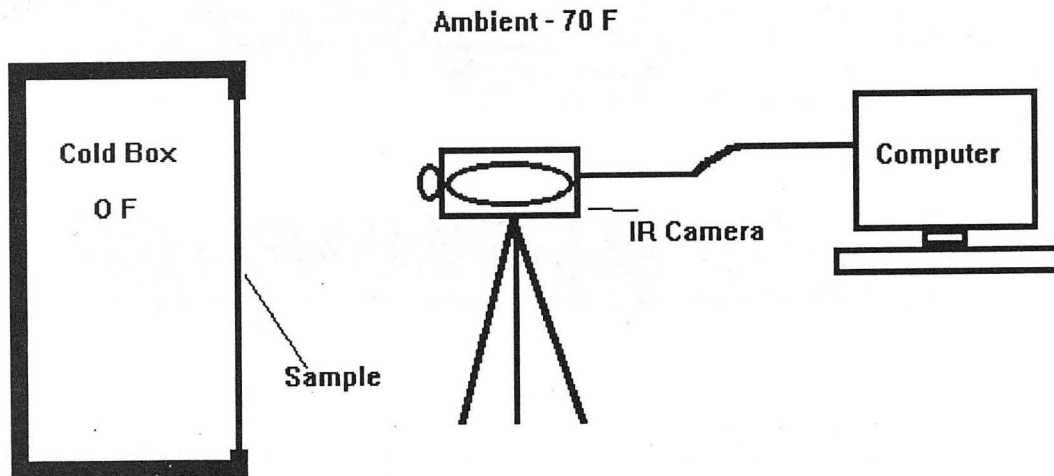

Figure 2: Schematic cross-section of infrared radiometer and cold box facility. The infrared camera records the warm side temperature distribution of a sample placed between the cold box and ambient. The closer the sample's (or part of the sample's) warm side temperature is to ambient, the better an insulator it is. A computer, attached to the infrared radiometer, allows for quick and versatile post-processing.

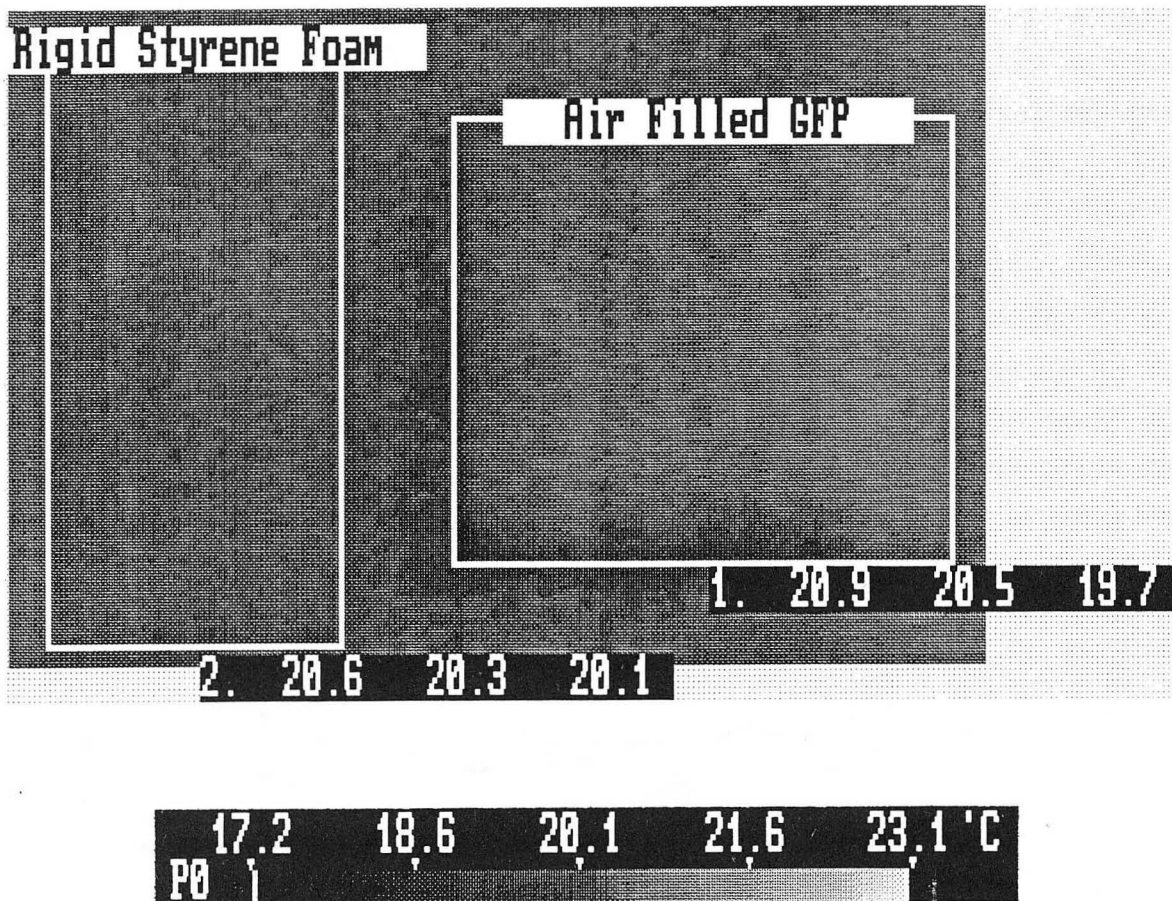

Figure 3: Infrared image of the warm side of a 5.1 cm (2 in) thick rigid styrene board with an insert containing a 5.1 cm (2 in) thick prototype air GFP. The back of the panel faces a cold box at -12.1 C (10.1 F); ambient temperature is 22.5 C (72.5 F). The warm side temperature of the styrene board averages 20.3 C (68.5 F) with a maximum of 20.6 C (69.1 F) and a minimum of 20.1 C (68.2 F) while the warm side of the air GFP insulation averages 20.5 C (68.9 F) with a maximum of 20.9 C (69.6 F) and a minimum of 19.8 C (67.6 F). The lack of contrast in this thermograph indicates uniform temperatures. A temperature grey-scale is shown at the bottom of the figure. Since surface temperatures correspond to heat loss rates, a higher warm side temperature implies a lower heat loss rate. Given an R-value of 35 m-K/W ($R\ 5\text{ hr-ft}^2\text{-F/Btu-in}$) for styrene, the R-value for the air GFP is calculated at 37 m-K/W ($R\ 5.4\text{ hr-ft}^2\text{-F/Btu-in}$).

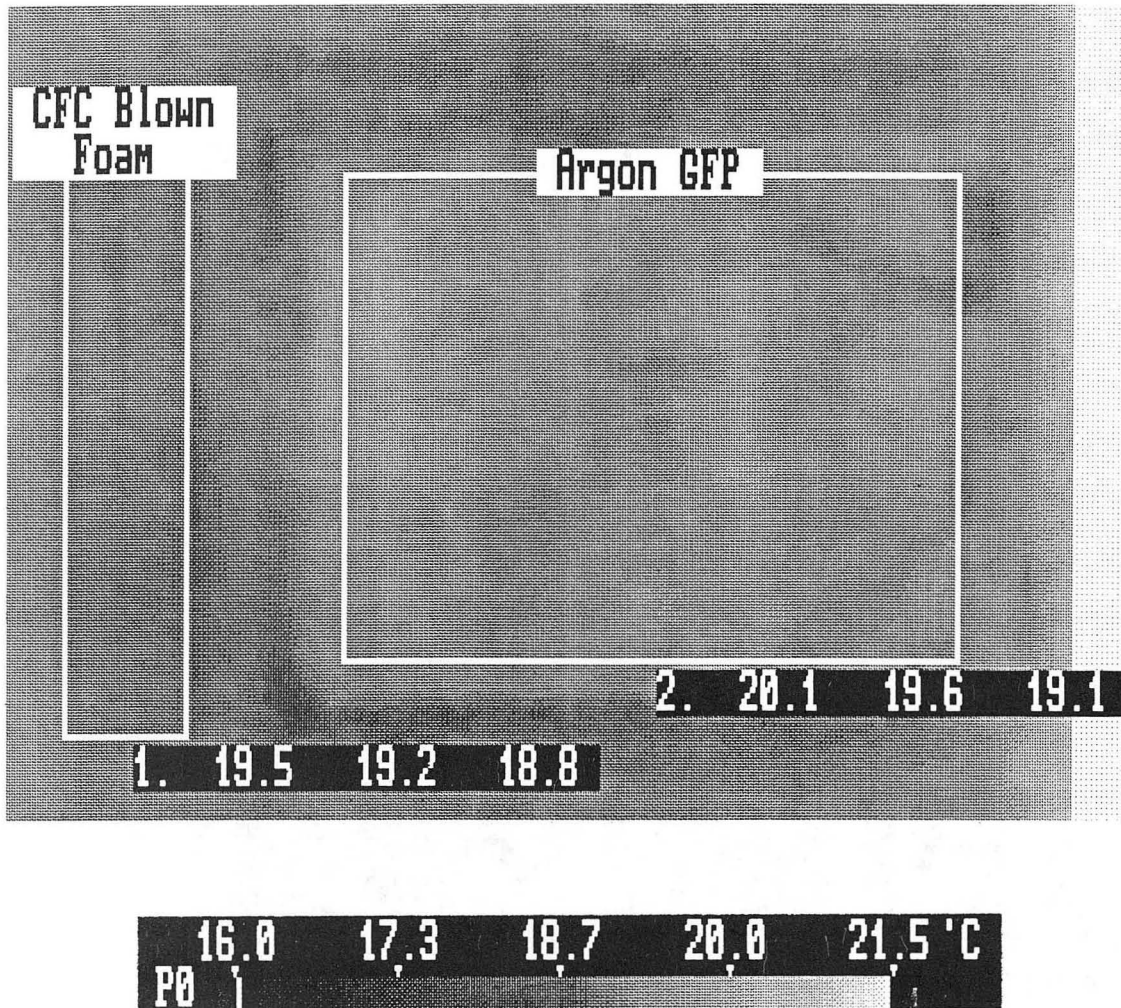

Figure 4: Infrared image of the warm side of a 2.6 cm (1 in) thick sample of CFC-blown foam with an insert containing a 2.6 cm (1 in) thick prototype argon GFP. The back of this assembly faces a cold box at approximately $-18.6\text{ }^{\circ}\text{C}$ ($-1.5\text{ }^{\circ}\text{F}$); ambient temperature is approximately $22\text{ }^{\circ}\text{C}$ ($71.6\text{ }^{\circ}\text{F}$). The warm side temperature of the CFC blown foam averages $19.2\text{ }^{\circ}\text{C}$ ($66.6\text{ }^{\circ}\text{F}$) with a maximum of $19.4\text{ }^{\circ}\text{C}$ ($66.9\text{ }^{\circ}\text{F}$) and a minimum of $18.9\text{ }^{\circ}\text{C}$ ($66.0\text{ }^{\circ}\text{F}$) while the warm side of the GFP insulation averages $19.6\text{ }^{\circ}\text{C}$ ($67.3\text{ }^{\circ}\text{F}$) with a maximum of $20.1\text{ }^{\circ}\text{C}$ ($68.2\text{ }^{\circ}\text{F}$) and a minimum of $19.1\text{ }^{\circ}\text{C}$ ($67.3\text{ }^{\circ}\text{F}$). In this figure, warmer areas are lighter and colder areas are darker. A temperature grey-scale is shown at the bottom of the figure. Since surface temperatures correspond to heat loss rates, a higher warm side temperature implies a lower heat loss rate. If the R-value of the CFC blown foam is taken as $R\ 50\text{ m-K/W}$ ($R\ 7.2\text{ hr-ft}^2\text{-F/Btu-in}$), the R-value of this argon filled GFP is calculated at $R\ 55\text{ m-K/W}$ ($R\ 7.9\text{ hr-ft}^2\text{-F/Btu-in}$).

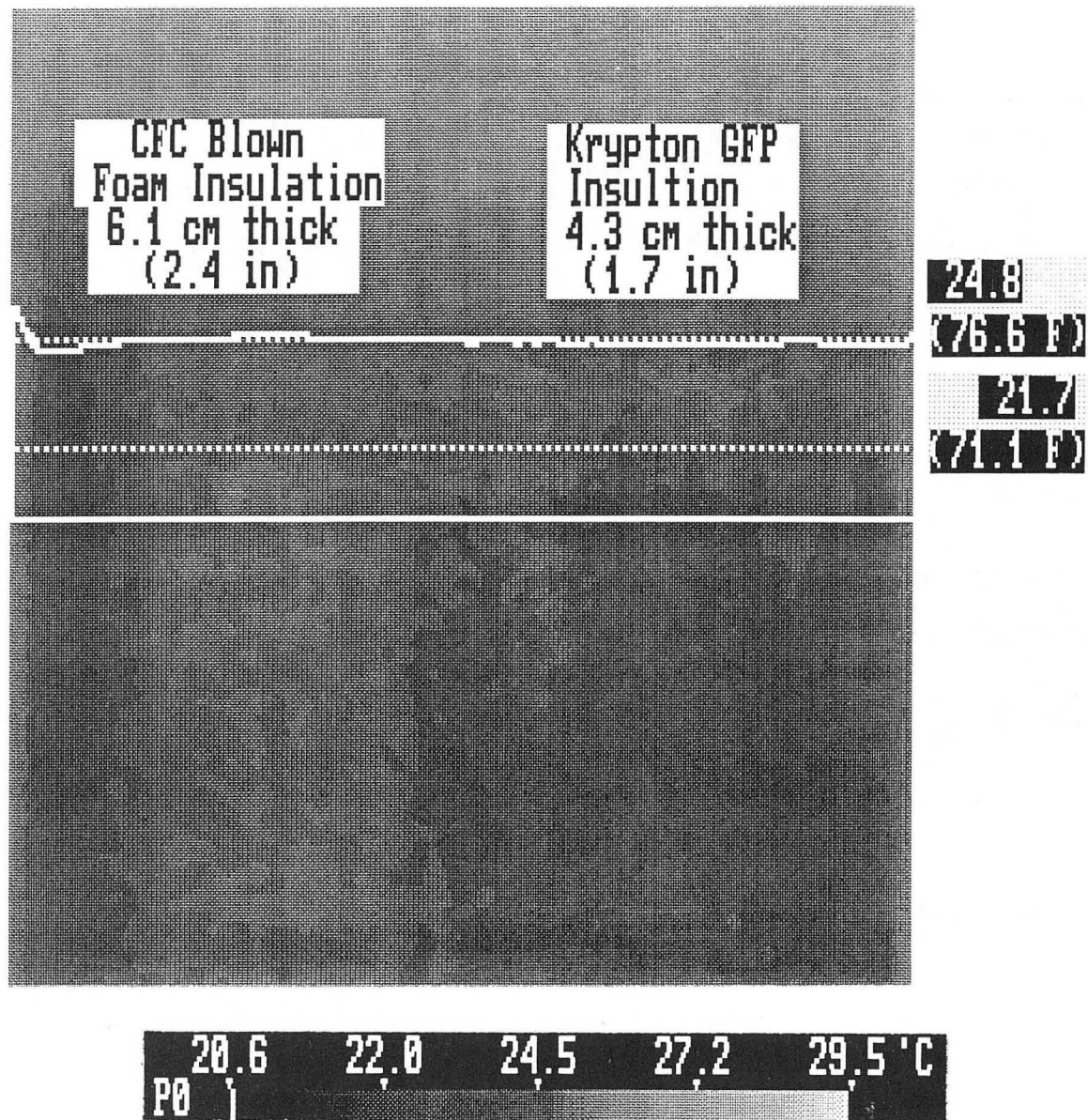

Figure 5: Infrared image of the door on a real freezer. The freezer is operating at about -20.5 C (-4.9 F) with an ambient temperature of 26.7 C (80 F). Half of the freezer door was left as manufactured (with 6 cm (2.4 in) of CFC blown foam); the other half was retrofitted with 4.3 cm (1.7 in) of krypton gas-filled panels. In this figure, warmer areas are lighter in shade and colder areas are darker. A temperature grey-scale is shown at the bottom of the figure. Since surface temperatures correspond to heat loss rates, a higher warm side temperature implies a lower heat loss rate. The infrared photo shows no significant difference (the resolution of the camera is 0.1 C) between the warm side temperature of both sides of the freezer door, indicating that 4.3 cm (1.7 in) of GFPs are as good an insulator as 6 cm (2.4 in) of CFC blown foam. (The average surface temperature is 24.8 C (76.6 F) across the solid white line. A second line at a temperature of 21.7 C (71.1 F) is used to define the scale.)

While infrared thermography is excellent for a quick comparison of the thermal performance of different specimens, it is not presently a developed technique to determine R-values. For this reason, several samples were fabricated and sent to Oak Ridge National Laboratory (ORNL) for independent testing. The GFP specimens were tested in the ORNL Advanced R-matic Apparatus which was designed to meet ASTM C 518, Configuration B (two transducers, both faces) [4]. Vertical heat flow conditions were tested with both heat flow up and heat flow down. The mean temperature was approximately 24 C (75 F) with a temperature difference of approximately 22.2 C (40 F). The apparatus is calibrated as specified by ASTM C 518 with an estimated uncertainty of $\pm 3\%$ for homogeneous specimens. The specimens measured 40.6 x 40.6 x 2.5 cm (16 x 16 x 1 in.) with a metering area of 25.4 x 25.4 cm (10 x 10 in.) to insure one dimensional heat transfer measurement and minimal edge effects. Note that this standard advises against its use for measuring inhomogeneous and/or anisotropic material. Because of the nature of the baffle used in these samples, they could be considered inhomogeneous. However, IR thermography and finite element modeling indicate one dimensional heat transfer. Given this and the smaller metering area, the heat flux measurements should be an appropriate evaluation of thermal resistance.

The specimens tested at ORNL were intended to demonstrate the general gas filled panel approach and were not optimized or designed for mass production. The one inch specimens were encased in a rigid styrene foam bivalve for a total test thickness of two inches. "Blank" styrene was also measured at ORNL and the effect of the mask was backed out by ORNL to arrive at the final results. The GFPs were constructed with one primary barrier comprised of two films sealed around the perimeter. The inside was split into two cavities by a heat sealed layer which served to limit mass transfer but was not hermetically sealed. Each cavity was filled with a baffle pile that consisted of three layers of 13 micron (0.5 mil) two sided metallized polyester film and two layers of "clear" 13 micron (0.5 mil) polyester film. The clear film was oversized (60 x 60 cm (24" x 24")) and crumpled up in an even but random fashion to create alternating clear and metallized layers. This produced a panel with eleven layers in one inch and with an average cavity size of less than 2.5 mm (0.1"). It is difficult to exactly quantify cavity scale due to the nature of the "crumpling". The intent with these panels was to effectively eliminate convective and radiative heat transfer. Except for the use of ultra thin films, solid conduction minimizing was not attempted.

Results from ORNL [5] are summarized in Table 3 and indicate prototype performance levels close to predicted levels. These tests found that the difference between heat flow up and heat flow down was less than 1%; this is within the 2% reproducibility of the R-matic. This finding indicates that the contribution of convection to heat transfer has been effectively eliminated. The differences between measured and projected R-values for the argon and krypton GFPs is primarily attributed to solid conduction through the large numbers of baffle layers. In addition, decreased performance may be attributed to fill concentrations less than 100%. However, oxygen concentration measurements (a crude measurement of gas fill) indicate that fill concentrations are better than 98%.

Table 3 -- Measured R-values from the ORNL R-Matic and Projected R-values in m-K/W (hr-ft²-F/Btu-in)

	ORNL Measured	Projected
Air GFP	36.1 (5.2)	36 (5.2)
Argon GFP	49.3 (7.1)	55 (8)
Krypton GFP	86.7 (12.5)	105 (15)

MANUFACTURING AND APPLICATIONS

The large scale manufacture of GFPs will not require the development of any substantially new materials processing technologies. The use of finished, roll stock material components makes the assembly of the panels relatively simple. Existing machinery from the food packaging industry such as thermoformers, impulse heat sealers, and bag making and wrapping machines can be used to manufacture GFPs at high line rates. Complete machines, known as form, fill and seal equipment, routinely used in the food packaging industry, can rapidly encapsulate the baffle with a barrier material, vacuum flush, gas back fill, and seal the panel into a final product.

Prototypes tested to date have been filled with a simple gas-filling apparatus. Fill percentages using this apparatus are generally in the 90-98% range. Advanced gas-filling methods using vacuum chambers are expected to yield GFPs with fill fractions of 98%-100%; these gas fill percentages have been met in both the window and food industries using vacuum chamber equipment.

Product lifetimes are a function of barrier material gas transmission rates and sealing quality. Barrier materials used in prototypes to date are taken from applications in the food packaging industry and have O₂ transmission rates of 0.79 cc/m²-day-atm (0.05 cc/100in²-day-atm) at 296 K (73.4 F) and 0% R.H. We expect further development of these barrier materials to produce barriers with even lower transmission rates which will be acceptable for use in GFPs. While GFPs should be designed for high lifetime gas retention rates, it should be noted that a failure of the barrier material will degrade the performance of a GFP to no less than that of an air GFP, R 36 m-K/W (R 5.2 hr-ft²-F/Btu-in). On the other hand, the failure of the barrier material in some vacuum insulations may degrade performance to significantly lower R-values.

One of the challenges in developing GFPs is to create a structural baffle which can be substituted for and/or used in conjunction with foam-in-place applications (i.e., refrigerator/freezers). Work on this task has only recently begun and initial attempts have been encouraging. Figure 6 shows a recently developed first generation structural GFP with a density of only 38 kg/m² (2.4 pcf) supporting six bricks. The bricks exert a force of 700 N (1 psi) onto the panel. Under this load,

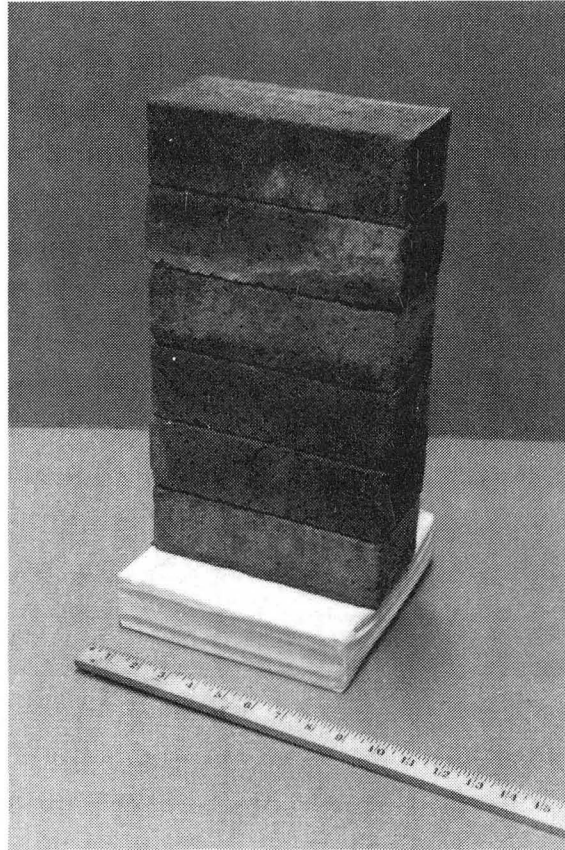

Figure 6: This photograph shows a first generation structural GFP prototype carrying a load of six standard bricks. The mass of the load is 13 kg (28.6 lb). The panel measures 20 x 20 x 5 cm. (8 x 8 x 2 in) and has a density of approximately 38 kg/m³ (2.4 lb/ft³).

this 50 mm (2 in.) thick GFP elastically deflects approximately 0.006 m (0.25 in). This sample is also exceptionally stiff in torsion. Note that this panel is constructed differently than the flexible panels sent to ORNL. Preliminary infrared testing shows slightly lower performance due to solid conduction. Development is continuing with a focus on optimizing the tradeoffs between structural and thermal performance.

The immediate applications for GFPs include krypton GFPs in refrigerator/freezer walls and argon GFPs in manufactured housing wall panels. In both of these applications, wall thickness and energy use are a premium and GFP's offer R/thickness values significantly higher than standard practice. In addition to saving space, higher R/thickness values also conserve costly structural lumber in building applications.

CONCLUSIONS

Preliminary research efforts aimed at developing prototype gas-filled panel insulations indicate that such materials can perform significantly better than conventional CFC-blown foams and can be built at a reasonable cost using a novel configuration of commercially available materials. Performance values of approximately R36 m-K/W (5.2 hr-ft²-F/Btu-in), R55 m-K/W (8 hr-ft²-F/Btu-in), and R105 m-K/W (15 hr-ft²-F/Btu-in) at 273 F (32 F) are expected for air, argon, and krypton GFPs, respectively. The measured thermal performance of prototypes tested at ORNL approached these values with R36.0 m-K/W (5.2 hr-ft²-F/Btu-in), R49.3 m-K/W (7.1 hr-ft²-F/Btu-in), and R86.7 (12.5 hr-ft²-F/Btu-in), respectively. Infrared thermography has also verified performance levels superior to those of CFC-blown foams.

A continuing research and development effort is underway to optimize designs for added thermal performance improvements, improve component materials, and compatibility with fabrication technologies. Issues of structure, lifetime performance, and cost effectiveness will be addressed. In conjunction with the building and appliance industries and interested utilities, prototypes will be built and tested in refrigerator/freezer and building walls. Particular attention will be focused on the manufacturing processes involved. Further heat transfer measurements and other building code related tests (e.g., flame spread) are planned.

ACKNOWLEDGMENTS AND DISCLAIMER

The research reported here was funded, in part, by the California Institute for Energy Efficiency (CIEE), a research unit of the University of California. Publication of research results does not imply CIEE endorsement of or agreement with these findings, nor that of any CIEE sponsor. This work was also supported by the Assistant Secretary for Conservation and Renewable Energy, Office of Building Technologies, Building Systems and Materials Division of the U.S. Department of Energy under Contract No. DE-AC03-76SF00098.

Considerable thanks go to Dave McElroy, Ron Graves, and the staff of the Building Materials Group at Oak Ridge National Laboratory for their timely thermal performance testing and analysis of prototypes. The authors also wish to thank their colleagues Fred Beck and Ian Sundly at Lawrence Berkeley Laboratory whose help in infrared thermography and sample preparation was invaluable.

Materials donated by M&D Balloons Incorporated of Brisbane CA, Metallized Products Incorporated of Winchester MA, Printpack Inc. of Atlanta GA, Schurpack Inc. of St. Joseph MO, Quantum Performance Films of Streamwood IL and EVAL Company of America of Lisle IL were used in the production of prototype samples.

REFERENCES

- [1] Arasteh, D., Selkowitz, S., and Wolfe, J., "The Design and Testing of a Highly Insulating Glazing System for use with Conventional Window Systems." *Journal of Solar Energy Engineering, Transactions of the ASME*, Vol 111, February 1989.
- [2] Liley, P. E., "The Thermal Conductivity of 46 Gases at Atmospheric Pressure," Proceedings of the Fourth Symposium on Thermophysical Properties, College Park, Maryland 1968, American Society of Mechanical Engineers.
- [3] Rocky Mountain Institute. "The State of the Art: Appliances," Competitek, 1990. Snowmass, CO.
- [4] ASTM Standard, Designation C 518-85, "Standard Test Method for Steady-State Heat Flux Measurements and Thermal Transmission Properties by Means of the Heat Flow Meter Apparatus", Annual Book of ASTM Standards, Vol 04.06.
- [5] McElroy, D. L., and Graves, R. S., personal communications dated July 30, 1990, September 14, 1990, and December 5, 1990, Oak Ridge National Laboratory, Oak Ridge, Tennessee.

LAWRENCE BERKELEY LABORATORY
UNIVERSITY OF CALIFORNIA
INFORMATION RESOURCES DEPARTMENT
BERKELEY, CALIFORNIA 94720