

# Lawrence Berkeley National Laboratory

## Recent Work

### Title

MILLIMICROSECOND DISCRIMINATOR

### Permalink

<https://escholarship.org/uc/item/6fg909x7>

### Authors

Swift, David F.  
Perez-Mendez, Victor.

### Publication Date

1958-12-23

UNIVERSITY OF  
CALIFORNIA  
*Ernest O. Lawrence*  
*Radiation*  
*Laboratory*

MILLIMICROSECOND DISCRIMINATOR

TWO-WEEK LOAN COPY.

*This is a Library Circulating Copy  
which may be borrowed for two weeks.  
For a personal retention copy, call  
Tech. Info. Division, Ext. 5545*

## **DISCLAIMER**

This document was prepared as an account of work sponsored by the United States Government. While this document is believed to contain correct information, neither the United States Government nor any agency thereof, nor the Regents of the University of California, nor any of their employees, makes any warranty, express or implied, or assumes any legal responsibility for the accuracy, completeness, or usefulness of any information, apparatus, product, or process disclosed, or represents that its use would not infringe privately owned rights. Reference herein to any specific commercial product, process, or service by its trade name, trademark, manufacturer, or otherwise, does not necessarily constitute or imply its endorsement, recommendation, or favoring by the United States Government or any agency thereof, or the Regents of the University of California. The views and opinions of authors expressed herein do not necessarily state or reflect those of the United States Government or any agency thereof or the Regents of the University of California.

UCRL-8569  
Instruments

UNIVERSITY OF CALIFORNIA  
Lawrence Radiation Laboratory  
Berkeley, California  
Contract No. W-7405-eng-48

MILLIMICROSECOND DISCRIMINATOR  
David F. Swift and Victor Perez-Mendez  
December 23, 1958

Printed for the U. S. Atomic Energy Commission

Printed in USA. Price 50 cents. Available from the  
Office of Technical Services  
U. S. Department of Commerce  
Washington 25, D. C.

MILLIMICROSECOND DISCRIMINATOR

David F. Swift and Victor Perez-Mendez

Lawrence Radiation Laboratory  
University of California  
Berkeley, California

December 23, 1958

ABSTRACT

A discriminator circuit for use with millimicrosecond counting equipment is described here. The main characteristics of this unit are its good response to pulses as short as 3 millimicroseconds and the fast recovery time which is less than 0.15 microsec.

## MILLIMICROSECOND DISCRIMINATOR

David F. Swift and Victor Perez-Mendez

Lawrence Radiation Laboratory  
University of California  
Berkeley, California

December 23, 1958

### I. INTRODUCTION

A discriminator device is a necessary element in most electronic counting arrangements in order to determine the voltage level at which pulses are fed to the recording device. Standard discriminator circuits with good stability are in common use for circuits operating in the microsecond region.<sup>1</sup>

The requirements on discriminators operating in the millimicrosecond ( $\mu\text{sec}$ ) region are even more exacting. In addition to good stability performance they are often required to have comparably short resolving times in order to make full use of the "speed" towards which millimicrosecond circuitry is developing.

The discriminator described here was designed with these two requirements in mind. Since the output voltages of the "fast" coincidence circuits in current use at UCRL are less than 1 volt, these units have been designed to operate at this input level and to have a resolving time equal to that of the fastest scalers in common use. This resolving time is approximately  $0.1 \mu\text{sec}$  for the Hewlett-Packard Model-520 prescaler.

### II. CIRCUIT DESCRIPTION

The main elements of the discriminator are shown in the block diagram, Fig. 1. The complete circuit diagram is seen in Fig. 2. Three units of this kind are assembled on a single rack for compactness. Each unit produces 2 outputs designated as (1) fast, and (2) slow, which are used to drive the Hewlett-Packard prescalers or the standard UCRL scalers.

The input stage uses an E180F as a shunt-compensated linear amplifier having a fixed gain of 3.5 with a rise time of  $6 \mu\text{sec}$ . The terminal input impedance is 125 ohms to provide a match to RG-63/U cable.

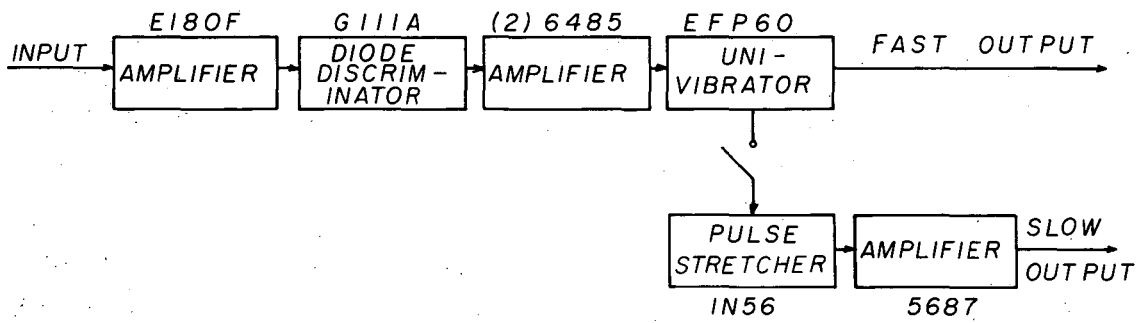

MU-16662

Fig. 1. Block diagram.



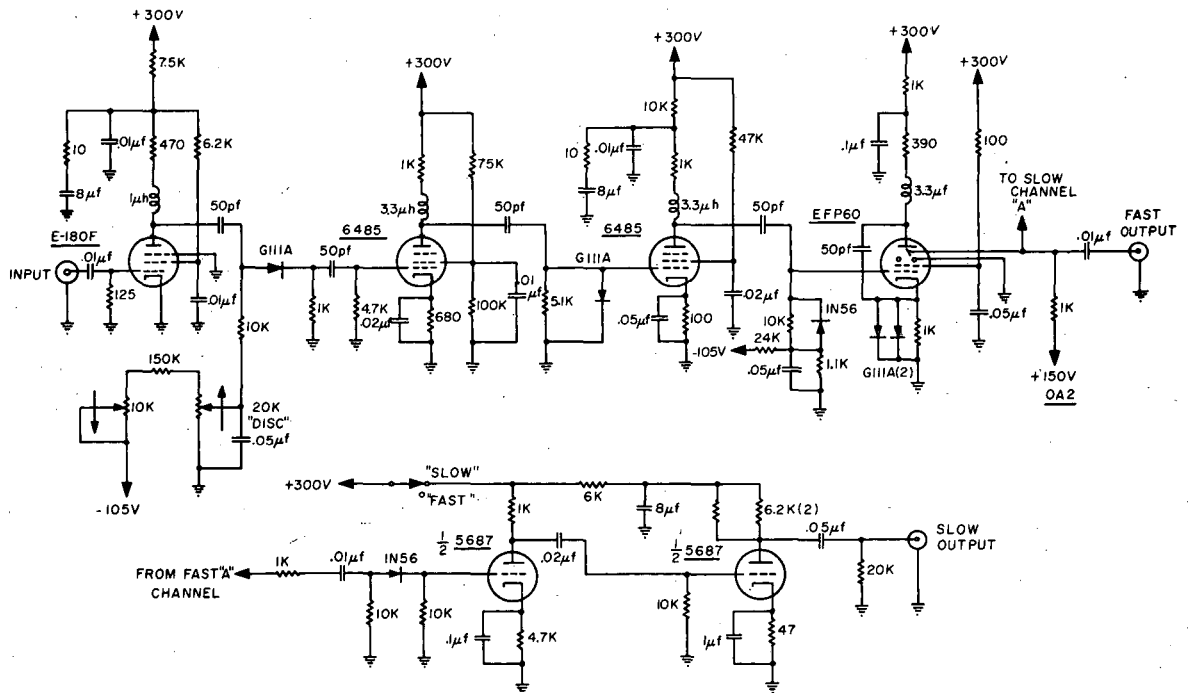

MU-17005

Fig. 2. Circuit diagram.

This circuit is placed before the diode discriminator to give sufficient amplification of input signals to increase discriminator precision and minimize the effects of uncertainty due to the lack of abruptness of the diode break characteristic.

The discriminator stage is a series voltage-comparator circuit using a G111A diode. The reference voltage is obtained from a bleeder network across the minus 105v bias line. Two potentiometers are provided for varying this voltage, (1) a front-panel control labeled "DISC" and (2) a rear control to initially equalize the discriminator level of all three channels. In order to minimize the effects of pulses feeding through the diode shunt capacitance, an RC neutralizing network is included.

The output from the comparator circuit could be used directly to trigger the EFP60 secondary emission univibrator, but the voltage at this point is of the same order as the inherent instability level of the EFP60. Two cascaded 6485 tubes are used with a combined gain of 60 to provide an amplified signal substantially higher than the threshold level of the univibrator. The instability level of the EFP60 is now a small percentage of the triggering voltage, thus adding to the over-all stability of this unit.

The univibrator stage consists of an EFP60 tube to provide standardized pulses for driving the "Hewlett-Packard" 520A prescaler. The amplitude and shape of the output pulse is determined by the plate-to-cathode feedback loop.<sup>2</sup> The pulse is initiated by the application of a trigger from the amplifier stage and terminated after one half the period of the critically damped resonant circuit in the plate. The output is taken from the dynode and should have a terminal impedance of 125 ohms at the input of the prescaler. Dynode voltage is stabilized through use of an OB2. The grid bias voltage for the EFP60 is sufficient to prevent self-oscillation and also double pulsing from output overload. Diodes placed across the grid and cathode resistors substantially reduce element-voltage change due to high duty cycle. The fast output pulse is shown in Fig. 3(a).

In order to drive a conventional slow-speed scaler, the fast output is applied to a stretching and amplifying circuit to give an output pulse with longer duration and greater amplitude. These circuits may be energized by application of B+ voltage from the front-panel switch labeled "FAST-SLOW".

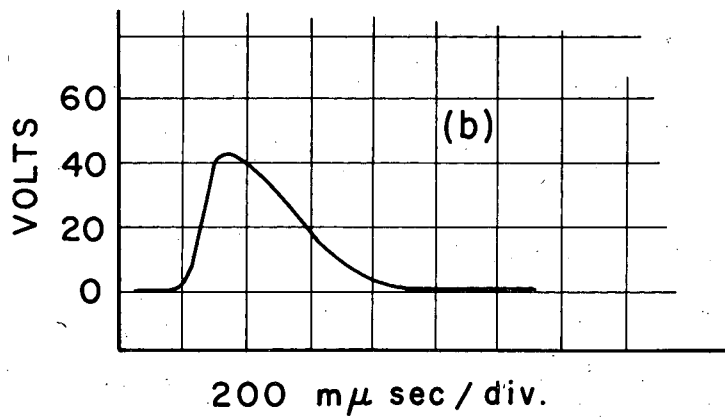
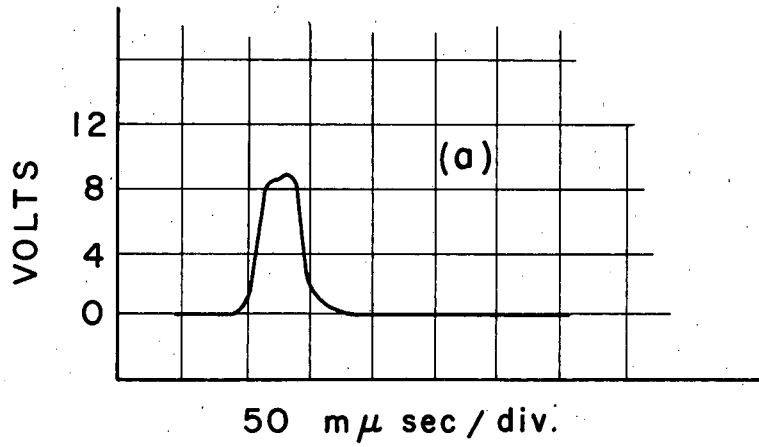

MU-16663

Fig. 3. (a) Fast output pulse. (b) Slow output pulse.

The fast output is then applied through an isolating resistor to a diode pulse stretcher in the grid circuit of the slow output amplifier. The two halves of a 5687 are used in cascade to amplify the stretched pulse to form the slow output as shown in Fig. 3(b).

### III. PERFORMANCE TESTS

The operating characteristics of this circuit were tested in various ways to determine the following properties:

- (a) The long-term stability of the discriminator level.
- (b) The discriminator level as a function of the input pulse widths.
- (c) The discriminator level as a function of the time interval between two pulses.

The results of these tests are seen in Figs. 3-6. From these graphs it can be seen that the circuit operates reliably for input pulses of approximately  $10^{-8}$  sec and has a resolving time of approximately  $1.5 \times 10^{-7}$  sec. For some applications, the delay time and "jitter" time in the fast pulse must be known. These times were measured at for a discrimination level of 0.5 volt; the delay time is 30  $\mu$ sec. The "jitter" time is less than 1.0  $\mu$ sec when measured with input pulses 0.1 volt higher than the triggering level of 0.5 volt.

### IV. SPECIFICATIONS

Input:	Impedance:	125-ohm resistive
	Amplitude:	min. -0.1 v
		max. -1.0 v
	Pulse Width:	min. 8 $\mu$ sec
max. 40 $\mu$ sec		
Fast Output:	Impedance:	125 ohms (when terminated)
	Amplitude:	+ 10 v
	Width:	30 $\mu$ sec
	Rise time:	8 $\mu$ sec
Slow Output:	Impedance:	1000 ohms capacitive
	Amplitude:	+40 v

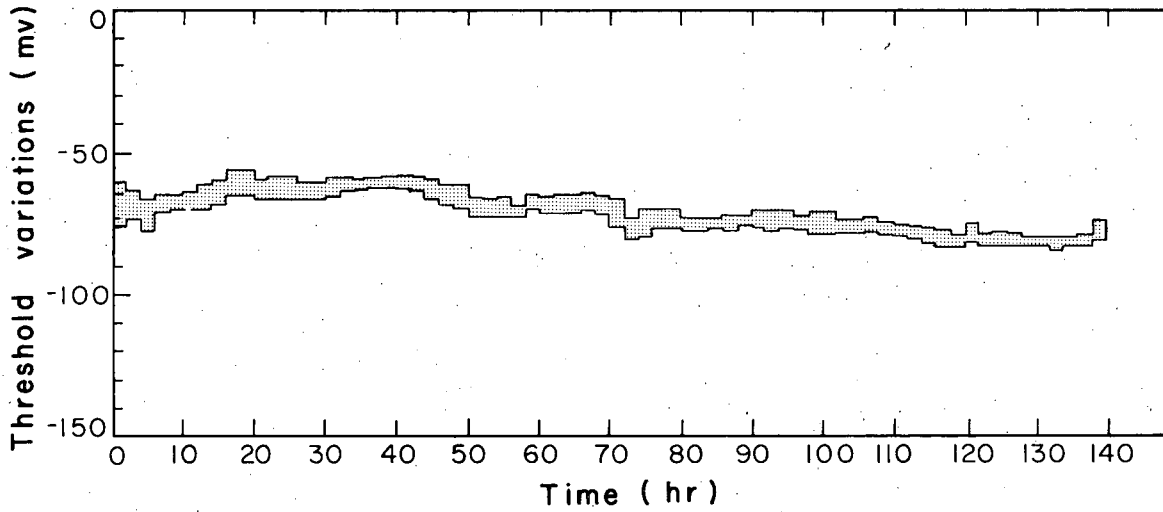

MU-16659

Fig. 4. Long-term stability of the discriminator level.

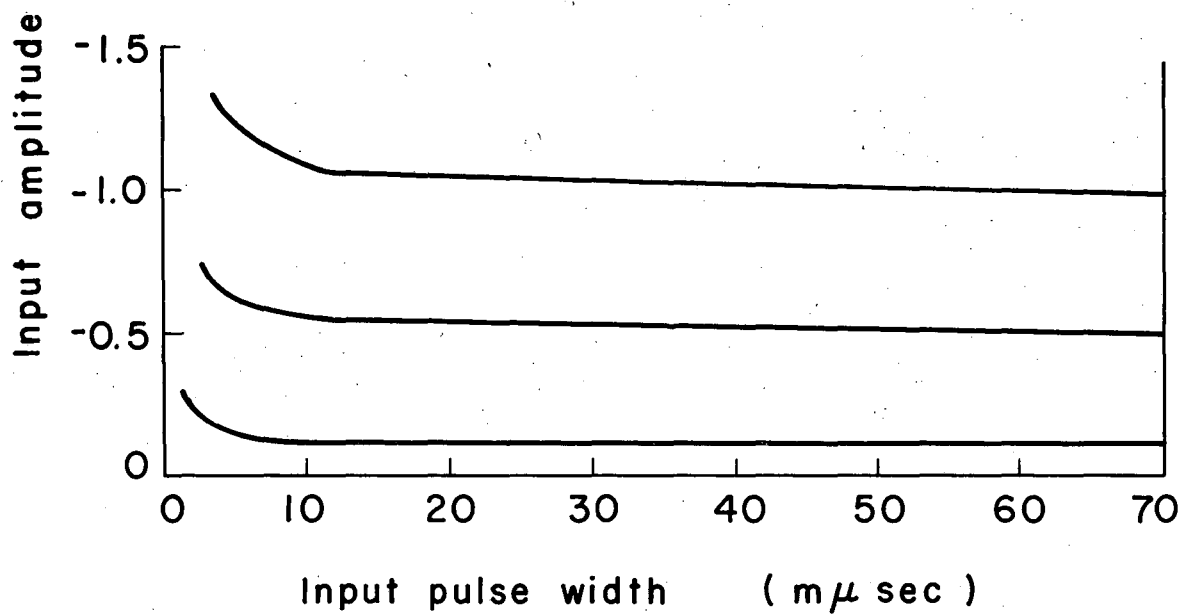

MU-16660

Fig. 5. Discriminator level as a function of input pulse widths.

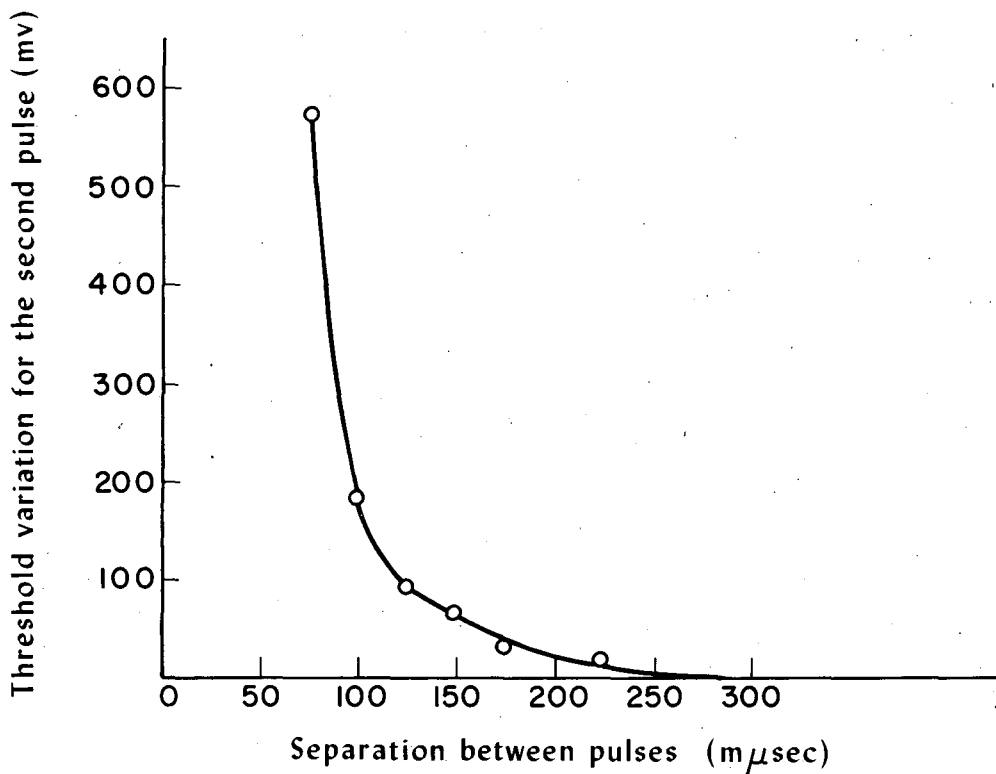

MU-17004

Fig. 6. Discriminator level as a function of the time interval between pulses.

Width: Triangular, 1  $\mu$ sec at base line  
Rise time: 0.1  $\mu$ sec  
Resolving Time: Fast channel: 2 pulses, 150  $\mu$ sec  
Slow channel: 2 pulses, 1  $\mu$ sec.  
Input Power: 117vac at 1.4 amp  
+300vdc at 40 ma per channel  
-105vdc at 7 ma per channel

#### V. ACKNOWLEDGMENTS

We wish to thank Dick Mack, Worrell Deuser, Jacques Mey, C. Norman Winningstad, and George Constantian for their help in the evaluation and testing of this unit.

#### REFERENCES

- <sup>1</sup>W. C. Elmore and M. Sands, Electronics (McGraw-Hill, New York, 1949), p. 99.  
J. Millman and H. Taub, Pulse and Digital Circuits (McGraw-Hill, New York, 1956), p. 458.
- <sup>2</sup>I. A. D. Lewis and F. H. Wells, Millimicrosecond Pulse Techniques (McGraw-Hill, New York, 1954), p. 232.



This report was prepared as an account of Government sponsored work. Neither the United States, nor the Commission, nor any person acting on behalf of the Commission:

- A. Makes any warranty or representation, express or implied, with respect to the accuracy, completeness, or usefulness of the information contained in this report, or that the use of any information, apparatus, method, or process disclosed in this report may not infringe privately owned rights; or
- B. Assumes any liabilities with respect to the use of, or for damages resulting from the use of any information, apparatus, method, or process disclosed in this report.

As used in the above, "person acting on behalf of the Commission" includes any employee or contractor of the Commission to the extent that such employee or contractor prepares, handles or distributes, or provides access to, any information pursuant to his employment or contract with the Commission.