

Lawrence Berkeley National Laboratory

Recent Work

Title

Induction Linac Systems Experiments for Heavy Ion Fusion

Permalink

<https://escholarship.org/uc/item/6hn191fh>

Authors

Herrmannsfeldt, W.B.
Bangerter, R.O.

Publication Date

1994-06-15



Lawrence Berkeley Laboratory

UNIVERSITY OF CALIFORNIA

Accelerator & Fusion Research Division

Presented at the Fourth European Particle Accelerator Conference,
London, England, June 27-July 1, 1994, and to be published in
the Proceedings

Induction Linac Systems Experiments for Heavy Ion Fusion

W.B. Herrmannsfeldt and R.O. Bangerter

June 1994

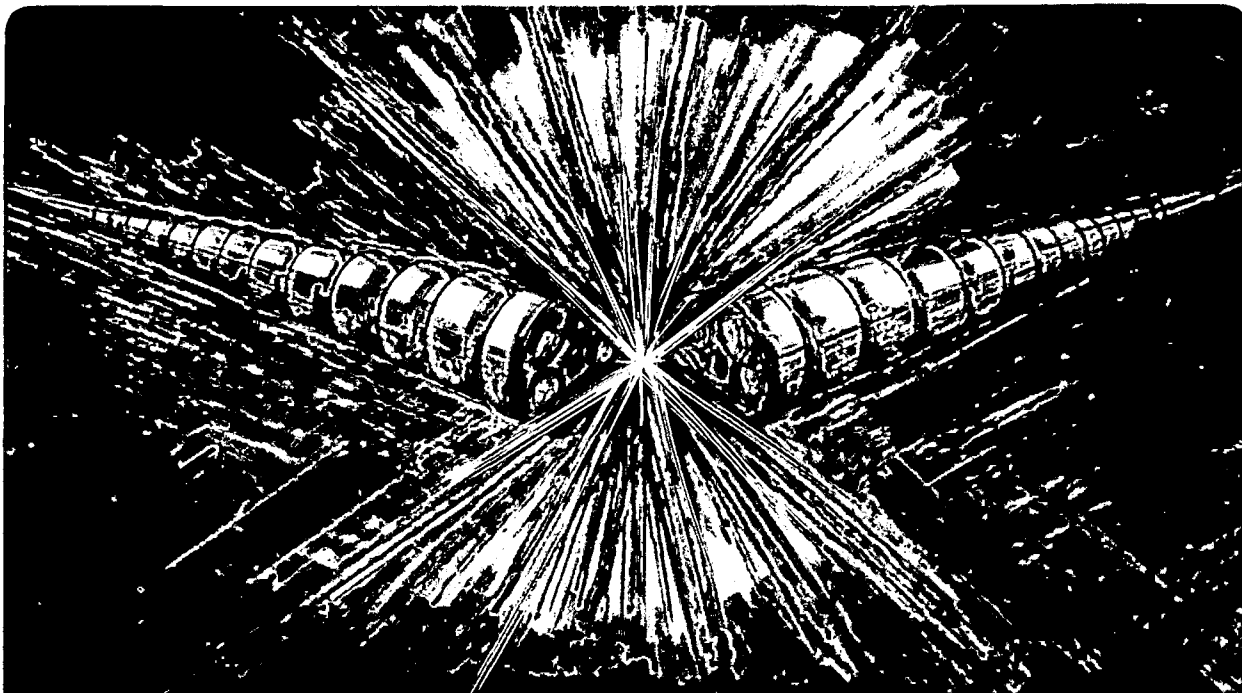

| LOAN COPY |
| Circulates |
| for 4 weeks |

Bldg. 50 Library.
Copy 2

LBL-35761

Induction Linac Systems Experiments for Heavy Ion Fusion

W.B. Herrmannsfeldt¹ and R.O. Bangerter²

¹Stanford Linear Accelerator Center
Stanford, CA 94309

²Accelerator and Fusion Research Division
Lawrence Berkeley Laboratory
University of California
Berkeley, California 94720

June 1994

INDUCTION LINAC SYSTEMS EXPERIMENTS FOR HEAVY ION FUSION*

W.B. HERRMANNSELDT¹ and R.O. BANGERTER²

¹Stanford Linear Accelerator Center, Stanford, California, USA

²Lawrence Berkeley Laboratory, Berkeley, California, USA

ABSTRACT

The Lawrence Berkeley Laboratory and the Lawrence Livermore National Laboratory propose to build at LBL the Induction Linac Systems Experiments (ILSE), the next logical step toward the eventual goal of a heavy ion induction accelerator powerful enough to implode or "drive" inertial confinement fusion targets. Though much smaller than a driver, ILSE will be at full driver scale in several important parameters. Nearly all accelerator components and beam manipulations required for a driver will be tested. It is expected that ILSE will be built in stages as funds and technical progress allow. The first stage, called Elise will include all of the electrostatic quadrupole focused parts of ILSE.

INTRODUCTION

The goal of the Heavy Ion Fusion Accelerator Research Program is to develop accelerators as drivers for inertial fusion energy production. In heavy-ion fusion, as in laser fusion, intense beams ignite small targets containing thermonuclear fuel. The beams from the accelerator are focused onto the target, located at the center of a target chamber. The targets will have a radius of several millimeters and the target chamber will have a radius of a few meters. Drivers must be reliable, durable, efficient, and must be capable of a high pulse repetition rate (several pulses per second).

During the last decade, nearly all of the numerous review committees^[1] have identified heavy-ion accelerators as the most promising class of drivers for power production. These accelerators are similar in many respects to other large accelerators. The new requirement for fusion is very high instantaneous beam power (about 4×10^{14} peak watts) in a beam that can be focused to hit a small target. Of the two methods of accelerating a heavy-ion beam, induction and radio-frequency accelerators, researchers in the US have chosen the induction accelerator for its relative simplicity. In Europe and elsewhere, the rf approach continues to be studied, so the aggregate effect worldwide is a broad, diverse program with a high likelihood of success. The development of inertial fusion into a viable energy option as called for by the National Energy Strategy^[2] probably will require an international cooperative effort. If so, a decision among the options shown

in Fig. 1, must be arrived at by mutual agreement among the participants.

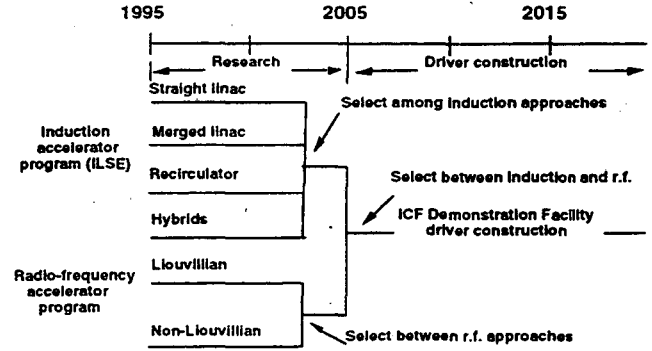

Fig. 1. A Program Plan showing the leading approaches to Heavy Ion Fusion and indicating where choices must be made if a single international HIF collaboration is to be realized.

The Induction Linac Systems Experiments (ILSE), was proposed to establish an experimental basis for induction accelerators in this new high-power regime. The design is full-driver scale in several parameters excepting mainly the energy, pulse length, and number of beams. As a first step, the electrostatic focused part of ILSE has been proposed as a project called Elise. Details of the Elise design will be discussed in the balance of this report.

SCIENTIFIC AND TECHNICAL GOALS OF ILSE

A schematic diagram of a generic induction accelerator designed to produce 100 kA of cesium ions at 4 GeV is shown in Fig. 2. It uses several methods to achieve 100 kA including: multiple beams, beam combining, acceleration, and longitudinal bunching. The figure shows typical values of ion kinetic energy, beam current, and pulse length at various points in the accelerator.

Initially each of 64 beams has a current of 0.42 A at ~ 2 MeV. The beams are accelerated to ~ 100 MeV in an electrostatically focused accelerator. Thus, the velocity of each particle increases by about a factor of 7. At ~ 100 MeV, the 64 beams are transversely combined in groups of four, creating 16 beams. In the electrostatic-focused section, the physical length of the beams remains approximately constant; therefore, the combination of acceleration and merging increases the current of a single beam to $7 \times 4 \times 0.42 \text{ A} = 12 \text{ A}$. Acceleration to 4 GeV in the magnetically focused section produces an increase in velocity by a factor of 6.3 and would give a current of $\sim 75 \text{ A}$ per beam if the physical beam length

*Work supported by the U.S. Department of Energy, contracts DE-AC03-76SF00515 and DE-AC03-76SF00098.

remained constant. To further increase the current of each beam, it is necessary to compress the beam longitudinally by accelerating the tail to a slightly higher velocity than the head.

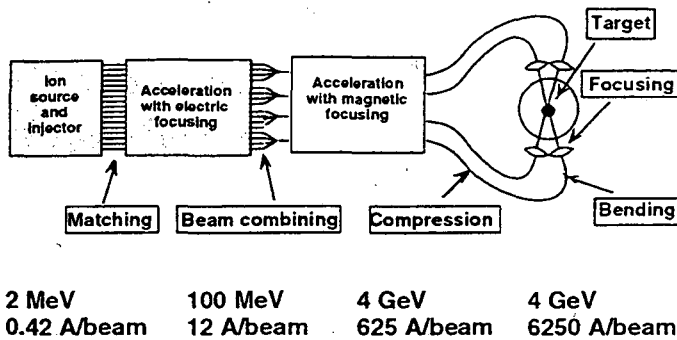

Fig. 2. The accelerator systems and beam manipulations found in typical heavy-ion driver designs are represented by boxes. A highly accurate alignment system, not shown, will be used throughout. The shaded boxes represent systems that have been tested in past experiments. The remaining issues, except target physics, will be tested in ILSE and its anticipated experimental program. Typical values of energy, current, and pulse length (representative of a broad range of possibilities) are shown by cross hatches.

The example in Fig. 2, assumes a compression factor of slightly more than 8 leading to a current of 625 A/beam. As the beam leaves the accelerator, the head-to-tail "velocity tilt" is adjusted so that the beam is compressed by another factor of 10 as it drifts toward the target. This final compression gives 6250 A/beam, or, with 16 beams, the aforementioned power of 4×10^{14} W.

Earlier experiments at LBL with the Single Beam Transport Experiment (SBTE), and with the four-beam Multiple Beam Experiment (MBE-4), tested much of the important beam physics on a small scale. To resolve the questions of scale, the design criterion for ILSE is that the beams should be at full driver scale in selected parameters. One of the most significant of these parameters is charge per unit length, which could not be tested at driver scale in SBTE and MBE-4. In the electrostatic focused section of ILSE, each beam should have a charge per unit length of $0.25 \mu\text{C}/\text{m}$.

By building and commissioning ILSE itself and by performing an experimental program, nearly all driver issues will be examined directly or in scaled form. While ILSE will initially use potassium ions, the results will be scaleable to ions of different mass, such as the mass 100-200 ions typical of a driver.

Beam quality (transverse and longitudinal emittance growth) is the most important issue to be studied in ILSE. In principle, three types of processes might contribute to emittance growth:

1. Random errors in transverse-focusing and accelerating waveforms.
2. Instabilities.

3. One-time manipulations, such as merging or the transition from one accelerator section to another.

THE DESIGN OF ELISE

The proposed location for the ILSE project is in an area that had previously been used as the experimental hall for the Bevatron/Bevalac. This location has space for the anticipated experiments including a beam combining area that would be the eventual location for the magnetic-quadrupole focused section of the full ILSE project. There is an area that can test beam physics issues for space-charge-dominated beams during bending. The bending section allows drift space to test longitudinal drift compression as described above, and also provides a space for a final focus experiment.

An option for the ILSE experimental program, not being proposed for the initial construction project, is a 360-degree bend providing a closed orbit. The recirculator apparatus would permit an increase of the effective number of focusing periods and the number of accelerating gaps by one to two orders of magnitude, thus providing a driver-class effective path length.

The already completed 2-MeV, K^+ ion source and injection column will form the first part of Elise as shown in Fig. 3. The injector is followed by a matching section to adjust the transverse beam conditions to the electrostatically focused injection linac that follows.

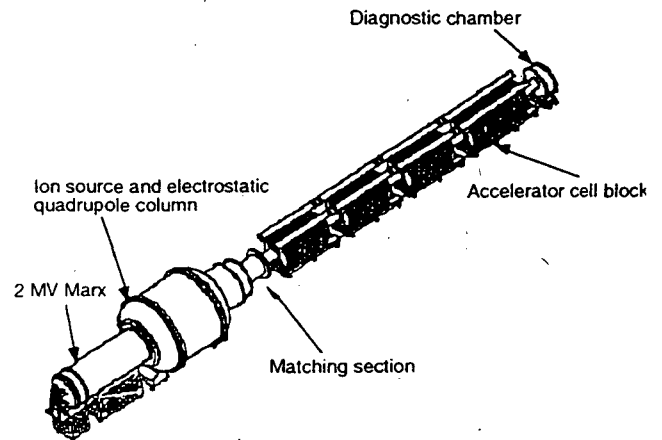

Fig. 3. Elise is composed of the existing 2-MeV, K^+ injector, a matching section, and the electrostatic-quadrupole focused section of linear induction accelerator, all of which combined form the first part of ILSE.

The ion source consists of a thermionic ion source for alkali metal ions from an alumino-silicate base. The accelerating column shown in Fig. 4, uses electrostatic quadrupoles to provide transverse focusing. The use of electrostatic quadrupoles in the injector column avoids the very high voltage gradients that would be required by a 2-MV Pierce column.

Induction linac accelerating modules, consisting of nine to fifteen induction cores as shown in Fig. 5, provide room for

four parallel beamlets. Additional injector columns will be needed to implement all four beams in order to perform experiments such as the beam merging.

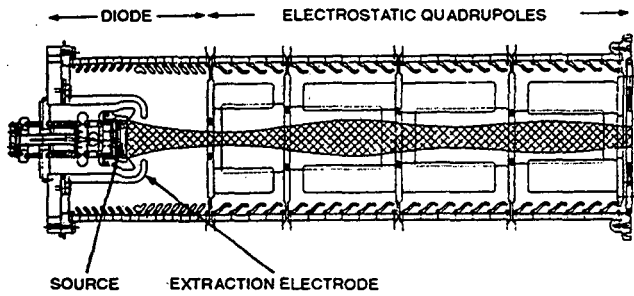

Fig. 4. The 2-MeV, K^+ injector with the electrostatic-quadrupole-focused accelerating column has delivered beams of 800 mA into a normalized emittance of $0.65\pi \text{ mm} \cdot \text{mrad}$.

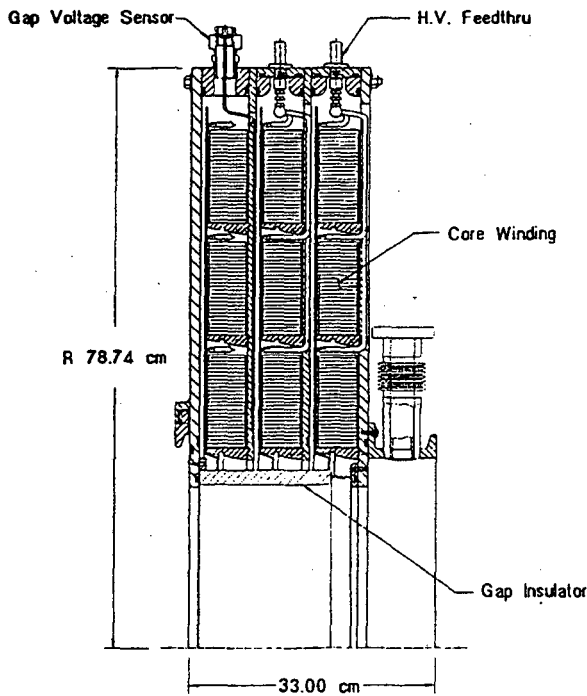

Fig. 5. The accelerating modules allow room for four beams in the electrostatic focused induction accelerator. Nine to fifteen separate cores are used in each module, giving an accelerating gap voltage of 100 to 170 kV for about $1 \mu\text{s}$.

Each induction core has about 5000 turns ferromagnetic material (e.g. Metglas®) and thin Mylar insulation.

Earlier experiments with the MBE-4 accelerator demonstrated that precise centering of the space-charge dominated beam is necessary to preserve beam quality. Figure 6 shows the schematic diagram for providing alignment information for the electrostatic quadrupoles to external sensors. Remotely actuated stepping motors provide the means for adjusting the alignment.

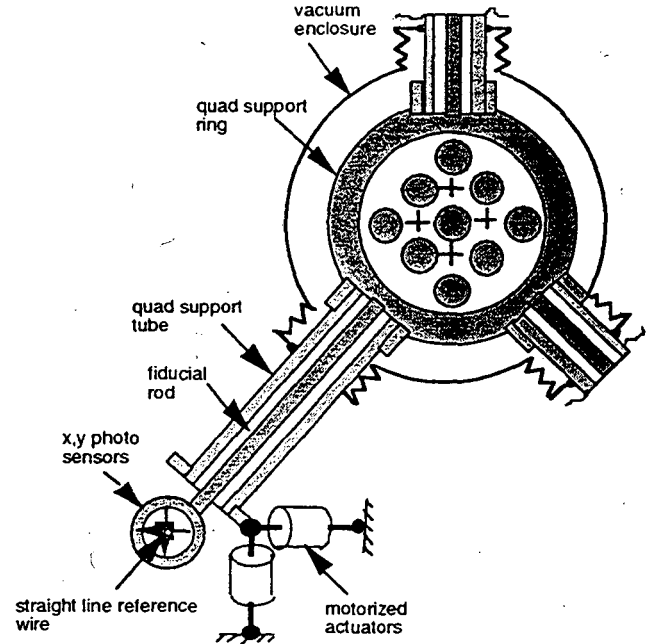

Fig. 6. The electrostatic quadrupoles are the only part of Elise that require precise alignment. Remotely controlled motorized actuators adjust the structure. The position of the quadrupole assemblies is determined by reference to photosensors attached to the ends of invar fiducial rods. The photosensors detect the position of a tensioned reference wire.

SUMMARY AND CONCLUSIONS

The ILSE project is the next logical step in driver development for heavy ion fusion, and is thus identified as a key element in a program for commercial power production from inertial confinement fusion. As the US moves toward the National Ignition Facility, and other national ICF programs develop facilities capable of demonstrating ignition, a parallel program is needed for the development of power plant drivers and for the development of the other elements of a fusion power system. These include target chambers with first-wall wall protection and tritium-breeding blankets, a target injection system, and a target fabrication facility.

REFERENCES

- [1] Review of the Department of Energy's Inertial Confinement Fusion Program (September 1990). Available from the Naval Studies Board, National Research Council, DOE, 2101 Constitution Ave., Washington, DC. Fusion Policy Advisory Committee, Final Report, U.S. Department of Energy Report DOE/S-0081 (September 1990).
- [2] National Energy Strategy, First Edition 1991/1992, US. Department of Energy, Washington, DC (February 1991). Available from the National Technical Information Service, US. Department of Commerce, 5285 Port Royal Rd., Springfield, VA 22161.

LAWRENCE BERKELEY NATIONAL LABORATORY
UNIVERSITY OF CALIFORNIA
TECHNICAL & ELECTRONIC INFORMATION DEPARTMENT
BERKELEY, CALIFORNIA 94720

