

Lawrence Berkeley National Laboratory

Recent Work

Title

THE ALPHA DECAY OF Gd151 AND Gd149

Permalink

<https://escholarship.org/uc/item/6jb002n2>

Authors

Siivola, A.

Graffe, G.

Publication Date

1964-07-08

University of California
Ernest O. Lawrence
Radiation Laboratory

TWO-WEEK LOAN COPY

*This is a Library Circulating Copy
which may be borrowed for two weeks.
For a personal retention copy, call
Tech. Info. Division, Ext. 5545*

THE ALPHA DECAY OF Gd^{151} AND Gd^{149}

Berkeley, California



DISCLAIMER

This document was prepared as an account of work sponsored by the United States Government. While this document is believed to contain correct information, neither the United States Government nor any agency thereof, nor the Regents of the University of California, nor any of their employees, makes any warranty, express or implied, or assumes any legal responsibility for the accuracy, completeness, or usefulness of any information, apparatus, product, or process disclosed, or represents that its use would not infringe privately owned rights. Reference herein to any specific commercial product, process, or service by its trade name, trademark, manufacturer, or otherwise, does not necessarily constitute or imply its endorsement, recommendation, or favoring by the United States Government or any agency thereof, or the Regents of the University of California. The views and opinions of authors expressed herein do not necessarily state or reflect those of the United States Government or any agency thereof or the Regents of the University of California.

UNIVERSITY OF CALIFORNIA
Lawrence Radiation Laboratory
Berkeley, California
AEC Contract No. W-7405-eng-48

gn n

THE 25-INCH LIQUID HYDROGEN BUBBLE CHAMBER
EXPANSION SYSTEM

F. Barrera, R. A. Byrns, G. J. Eckman, H. P. Hernandez,
D. U. Norgren, A. J. Shand, and R. D. Watt

July 8, 1964

THE 25-INCH LIQUID HYDROGEN BUBBLE CHAMBER
EXPANSION SYSTEM*

F. Barrera, R. A. Byrns, G. J. Eckman, H. P. Hernandez,
D. U. Norgren, A. J. Shand, and R. D. Watt

Lawrence Radiation Laboratory
University of California
Berkeley, California

July 8, 1964

INTRODUCTION

The 25-inch liquid hydrogen bubble chamber is the newest of five chambers built and operated under the direction of Professor Luis W. Alvarez of the Lawrence Radiation Laboratory at Berkeley. This chamber incorporates an expansion system that has several unique features. The chamber is expanded by movement of the top glass on a single-convolution bellows welded to the chamber perimeter. The expansion is controlled with a hydraulic-pneumatic system. As the chamber is expanded twice for each Bevatron pulse, two sets of stereo photographs are taken. The response time of the system is such that pulses can be accepted slightly over 150 msec apart.

This chamber also has some unique features in optics, inflatable gaskets, and magnet designs; these features are discussed in reference 1 but are not repeated here. Some design and operation parameters of the chamber are listed in the Appendix, and the general arrangement of the chamber and magnet assembly is shown in Fig. 1.

Design studies for this chamber were begun in 1960 under the direction of the late J. D. Gow. The chamber was first operated in November 1963 for an engineering run, and the physics run was begun in March 1964. The 25-inch chamber has completed 1.5 million pulses on the physics experiment; 700 000 photographs have been taken, of which 265 000 are in the double-pulse mode.

CHAMBER

The chamber body is a cylindrical vessel with a single-convolution bellows joining two sections. Flanges clamp glass windows to the chamber and the seal is made by inflatable gaskets. The chamber body is shown in Fig. 2.

The chamber body and flanges were cast from Kromarc-55, an austenitic stainless steel developed by Westinghouse Corporation. The selection of this material was based on an intensive investigation^[2] made by engineers at Brookhaven National Laboratory, to select a material for their 80-inch-chamber body.

Bellows

An "omega" bellows was designed with a single convolution. This was done to avoid any frequency-response problems of multiconvolution in which the bellows expands so rapidly that the first convolution only is deflected and overstressed. The bellows is made of two identical halves, which are first fusion welded to the chamber body, and then fusion welded together at the outer seam as shown in Fig. 3.

Design was based on a bellows movement of 0.250 inch, a maximum operating pressure of 150 psi internal pressure, and infinite fatigue life^[3]. The movement of 0.250 inch (0.125 inch on each side of the relaxed position) is about three times the movement necessary to expand the chamber. This movement value was based on an investigation of the compressibility of liquid hydrogen and liquid deuterium for which data was extrapolated below the saturated-vapor line^[4].

Fabrication and welding techniques had to be developed, and a test stand built to cycle two bellows simultaneously under the above conditions of motion and pressure.

The bellows welded to the chamber were fabricated from a low carbon (0.035%) 316-type stainless steel of 26 gage (0.0179 inch thick). The bellows were formed from a male die, and the edges were then machined and finally prepared by hand. Welding fixtures (shown on Figs. 4 and 5) were used for both the inside lip weld and the outside butt weld, with the outside welded last. The welding was performed in a universal-rotary-weld positioner with an "Airline" welding head equipped with RF controls. The weld was backed up with copper chill bars and completely shielded with argon gas on both sides. Previously two prototypes of this bellows were tested at room temperature for 3 300 000 cycles, and it was felt that the room-temperature test in conjunction with the excess movement satisfied basic safety requirements.

Other designs tested and found unsatisfactory were [5]:

1. Bellows made from a 304 stainless steel in which radial cracks appeared around the fusion butt weld. The repaired cracks began to open after 500 000 cycles at room temperature.
2. Bellows designed with a flanged lip at the outer diameter failed due to the notch effect at the inside of this weld.

Assembly

The chamber body is suspended inside the vacuum tank from the top plate by the support can. In operation the chamber is "captured" between the support can, which rigidly suspends the lower part of the chamber, and three drive rods, which control the movement of the bellows and the upper part of the chamber. Four support legs, bolted to the lower-chamber body, limit the bellows movement and act as guides on the upper-chamber body.

The support can is a 304 stainless steel cylinder 3/16-inch thick and flanged at both ends with a beam-window port cut in the cylindrical section.

The upper flange is bolted to the top plate and the lower flange is bolted to the lower flange of the chamber body.

The three drive rods are made from 304 stainless steel pipe Schedule 80, 1-1/2 in. in diameter and ≈ 40 inches long, with screw threads machined at each end. The lower ends of the rods are fixed to the upper chamber flange, whereas the upper ends of the rods guided through bronze bushings, pass through the top plate and then through multiple (four on each rod) vacuum seals. These vacuum seals consist of commercial "hycar" "O" rings in grooves designed for dynamic service, with lubrication provided by Dow-Corning DC-33 grease. Leakage of air into the main vacuum system through these seals was insignificant after 1.5×10^6 pulses (cycles). The leakage rate can be reduced by differential pumping across the four seals (three pump-outs are provided).

EXPANSION SYSTEM

It was felt that the expansion system designed around the concept of the moving top glass would satisfy some desirable criteria. These are:

1. Low Turbulence in the Liquid

Turbulence in a hydrogen bubble chamber causes "waviness" in the tracks formed by the bubbles. Worldwide experience has shown that piston-type expansion systems have less liquid turbulence than vapor-expansion systems, and the moving glass is simply the largest piston that can be designed in a chamber of a given volume.

2. Low Thermal Gradients

The chamber will vary in sensitivity if thermal gradients exist, and the photographs will show tracks of different intensities. A piston-type system has less heat load than a vapor-expansion system and the moving glass distributes the load uniformly. Furthermore the curved moving top glass initiates in the liquid a small lateral motion that prevents the formation of radial thermal gradients.

3. Fast Expansion

Fast expansion is necessary to prevent spontaneous boiling, and the compressed liquid hydrogen is a large energy source that makes possible fast expansion.

4. Fast Recompression

Fast recompression is desirable to condense existing bubbles and reduce heat load on the liquid. Although a certain amount of energy is necessary to recompress the chamber, the work is done at room temperature and there is no external heat load to the chamber liquid.

5. Uniform Operation

Particle entry to the sensitized chamber must be timed within 0.1 msec of the light flash to produce uniform and reproducible bubble count and size. The mechanism for controlling the expansion system is at room temperature; during the engineering run, this advantage of having the mechanism accessible at room temperature was used in the development of an expansion system that would produce reproducible conditions.

The expansion system as finally evolved is shown in Fig. 6. The expansion-recompression cycle is controlled with a hydraulic-mechanical-pneumatic system, and the entire system can be broken down into the following components:

1. Chamber

Energy for expansion is obtained from the compressed liquid hydrogen (at about 70 psi) inside the chamber.

2. Drive Rods and Drive-Rod Pistons

The three drive rods connect the upper chamber, top glass, and top-chamber flange to the hydraulic system.

3. Hydraulic System

The hydraulic oil system is a constant-volume oil-filled system that transfers the displacement of the pressure multiplier to the displacement of the drive-rod pistons.

4. Pressure Multiplier

The pressure multiplier consists of three pistons of different diameters driven by helium gas.

5. Helium Gas System

The helium gas system that drives the pressure multiplier is a fast expansion-recompression system similar to those used in other bubble chambers.

The entire expansion-system concept can be simplified if the major components are considered as two-piston combinations. One piston combination consists of a large-diameter piston representing the chamber and a small piston representing the three drive-rod pistons. The other piston combination is the pressure multiplier. The oil is contained in a cylindrical system of two different diameters, and if the oil is considered incompressible, the volume change swept out by the chamber piston will sweep the same volume change on the helium piston of the pressure multiplier. In operation, the chamber moves about 0.08 inch, which corresponds to the helium piston movement of 2-3/4 inches.

The chamber movement is estimated by means of movements electrical signals from linear transformers mounted on top of the support rods. A small correction for estimating the chamber movement must be included when the deflections of the drive rods (in compression) and the support can (in tension) are considered in the chamber expansion. The change in total deflection is about 0.005 inch, which means that the drive-rod pistons move 0.005 inch more than the total chamber bellows.

The mechanical expansion of the chamber bellows is physically limited by the two safety devices described below:

1. Support Legs

Four support legs bolted to the bottom half of the chamber body provide a fixed limit to the travel of the upper half of the chamber. These stops limit the bellows movement to 0.250 inch and protect the chamber against failure of the drive rods. These stops are also necessary during chamber assembly.

2. Drive-Rod Stops

An adjustable pair of stops attached to the ends of the drive rods outside the vacuum also limit the chamber travel. The motion allowed by these stops is less than 0.110 inch and is within the travel permitted by the fixed stops, with the final adjustment made after the cooldown has been completed. On the recompression stroke, the chamber is allowed to return to the lower drive-rod stops so that initial conditions for the next expansion are the same. On the expansion stroke the upper of these stops protects the chamber in case of gas-cushion failure.

The drive-rod pistons, fastened to the upper ends of the drive rods, are 3-1/2 inches in diameter. Oil seals are made with commercial "O" rings in grooves of standard design.

A hydraulic pump supplies oil under pressure (≈ 2500 psi) to the expansion system. Oil leakage is compensated for between pulses by opening a valve that connects the hydraulic pump to the oil circuit. Three pipes of equal impedance transfer oil from the three drive pistons to a manifold mounted on the pressure multiplier.

The spool of the pressure multiplier consists of three pistons on a single shaft. The upper piston (1-1/8 inch diameter) "sees" the oil. The

middle piston (6-inch diameter) "sees" helium from below and is vented to atmosphere from above. The third piston (2-inch diameter) is the cushion piston whose primary purpose is to eliminate impact on the downstroke (expansion) part of the cycle.

The cushion piston compresses the gas on the downstroke. The initial volume of the gas can be changed, and the initial gas pressure can be changed. This cushion system performs three functions:

1. Reduces impact on expansion. The gas "spring" prevents the piston from slamming into the body.
2. Provides adjustments for control of expansion pressure. The initial gas pressure and volume in the gas cushion contribute to the control of the piston movement and thus the chamber movement. Therefore the valley depth (expanded pressure) can be controlled by the gas-cushion pressure and volume.
3. Conserves some energy of expansion. Some of the work necessary to recompress the chamber is obtained from the compressed gas in the cushion.

The helium gas that drives the pressure multiplier operates in a closed system. Helium at 100 psi is normally applied to the helium piston. On expansion a quick-opening valve drops the pressure, the piston moves, and the chamber expands. Recompression of the liquid in the chamber is obtained by opening another quick-opening valve that reapplies helium pressure to the helium piston. The expansion and recompression quick-opening valves are the rubber-boot type designed to use Grove Flexflo components of 2-inch nominal size. These valves are driven by modified three-way Ross-solenoid-actuated valves of 3/4-inch nominal size. A commercial refrigeration compressor is used in a closed system with an expansion and a recompression tank.

EXPANSION-SYSTEM PERFORMANCE

Of the 700 000 pictures taken to date, 265 000 have been taken with the chamber operating in the double-pulse mode. For each separate Bevatron pulse, two beam pulses are sent to the chamber and the chamber expands for each beam pulse. The two expansions are slightly different because of leaky vent valves that allow plumes of gas to enter the chamber on the first pulse. The bubbles of gas are not fully compressed by the time the second pulse arrives, hence a shallower expansion.

Each expansion cycle is controlled separately to enable similar conditions to exist for each beam pulse. The entrance of each beam pulse is timed with respect to the expansion pressure so that the same number of bubbles per cm results, and each light delay is adjusted to give the same bubble size. The number and size of bubbles is specified by the physicist in charge of the experiment. A typical specification is 12 bubbles/cm in the chamber and 20- μ bubble size on the film.

The Bevatron is now limited to two beam pulses per Bevatron pulse because there are only two "rapid beam ejectors" (RBE). The chamber is limited to two beam pulses because of the leaky vent valves, which will be replaced by those of better design in the future. With the addition of another RBE at the Bevatron and the replacement of the leaky vent valves, the chamber should be able to take three beam pulses per Bevatron pulse.

Since June, when bubble chamber operations with deuterium began, 75 000 pictures have been taken. The only difference between operating conditions for hydrogen and those for deuterium is that chamber pressures are slightly higher for deuterium, as shown in Table I.

APPENDIX

Summary of SpecificationsChamber Assembly

Chamber body

Nominal i. d. (inches)	24
Maximum o. d. (inches)	30.75
Body height (inches)	14.75
Liquid height (inches)	10 at center 13 at outer radius
Volume (liter)	85
Material	Kromarc -55
Weight (lb)	491
Test pressure (psi)	250

Chamber flanges

Material	Kromarc -55
Weight, top (lb)	330
Weight, bottom (lb)	400

Expansion System

Type	Piston
Pulse rate (ppm)	12/24
Chamber pressure	
Before pulse (psig)	65
Expanded (psig)	≈ 35
Expansion-system driving fluid	Helium
Expansion valve	Modified 2-inch Grove Flexflo
Recompression compressor	Brunner two-stage
Rating (hp)	10
Discharge pressure (psig)	150

FOOTNOTES AND REFERENCES

* Word performed under the auspices of the U. S. Atomic Energy Commission.

1. F. Barrera, R. A. Byrns, G. J. Eckman, H. P. Hernandez, D. U. Norgren, A. J. Shand, and R. D. Watt, "The 25-Inch Liquid Hydrogen Bubble Chamber," Lawrence Radiation Laboratory Report UCRL-11384 (May 1964).
2. C. Goodzeit, "Evaluation of Stainless Steel Casting Alloys for 80-Inch Chamber Body and Associated Parts," Brookhaven National Laboratory Report E-95, BC-01-1G (July 1961).
3. J. O. Myall, "25-Inch Bubble Chamber, Design of Main Bellows and Inflatable Gaskets," Lawrence Radiation Laboratory Report UCID-1365 (May 1961).
4. J. O. Myall, "25-Inch Bubble Chamber, Main Bellows Test," Lawrence Radiation Laboratory Report UCID-1410 (July 1961).
5. G. J. Eckman, "Resume of 25-Inch Bubble Chamber Expansion Bellows Tests," Lawrence Radiation Laboratory Report UCID-1840 (January 1963).

Table I. Operating conditions for the 25-inch bubble chamber.

	<u>Hydrogen</u> (psig)	<u>Deuterium</u> (psig)
Chamber pressure	70	80
Expanded chamber pressure	≈ 40	≈ 45
Vapor pressure	55	70
Oil pressure	2000	2300
Helium pressure	95	110
Gas-cushion pressure	35	35

Under these conditions, the time for expansion is 9 msec and the time for recompression is 22 msec for both hydrogen and deuterium. A typical time-vs-pressure curve for hydrogen is shown in Fig. 7, which also shows the occurrences of beam entry and light flash.

FIGURE CAPTIONS

Fig. 1. Cross section of chamber and magnet.

Fig. 2. Cross section of chamber body.

Fig. 3. Bellows detail.

Fig. 4. Weld fixture for inside weld.

Fig. 5. Weld fixture for butt weld.

Fig. 6. Expansion system.

Fig. 7. Expansion cycle.

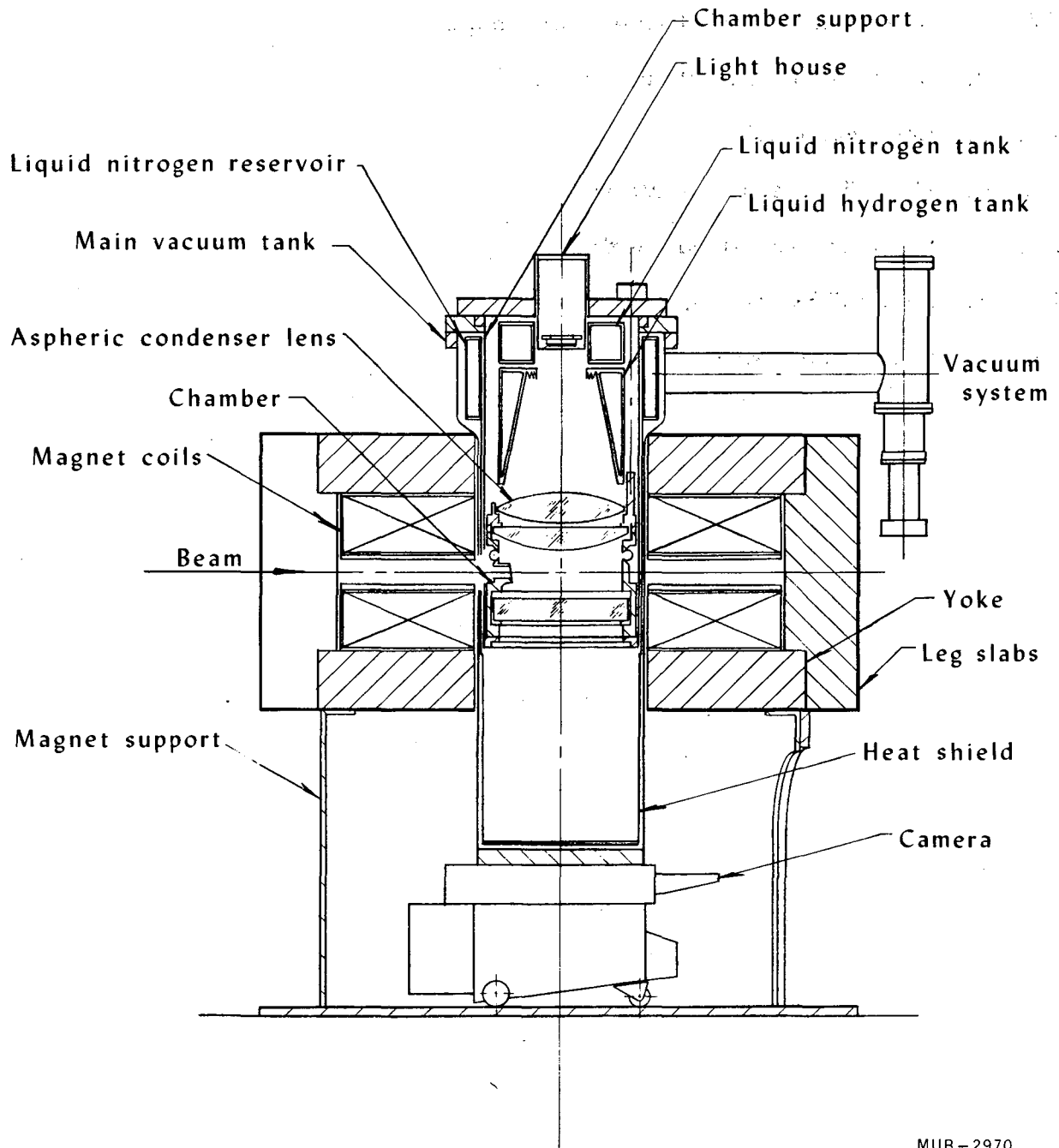
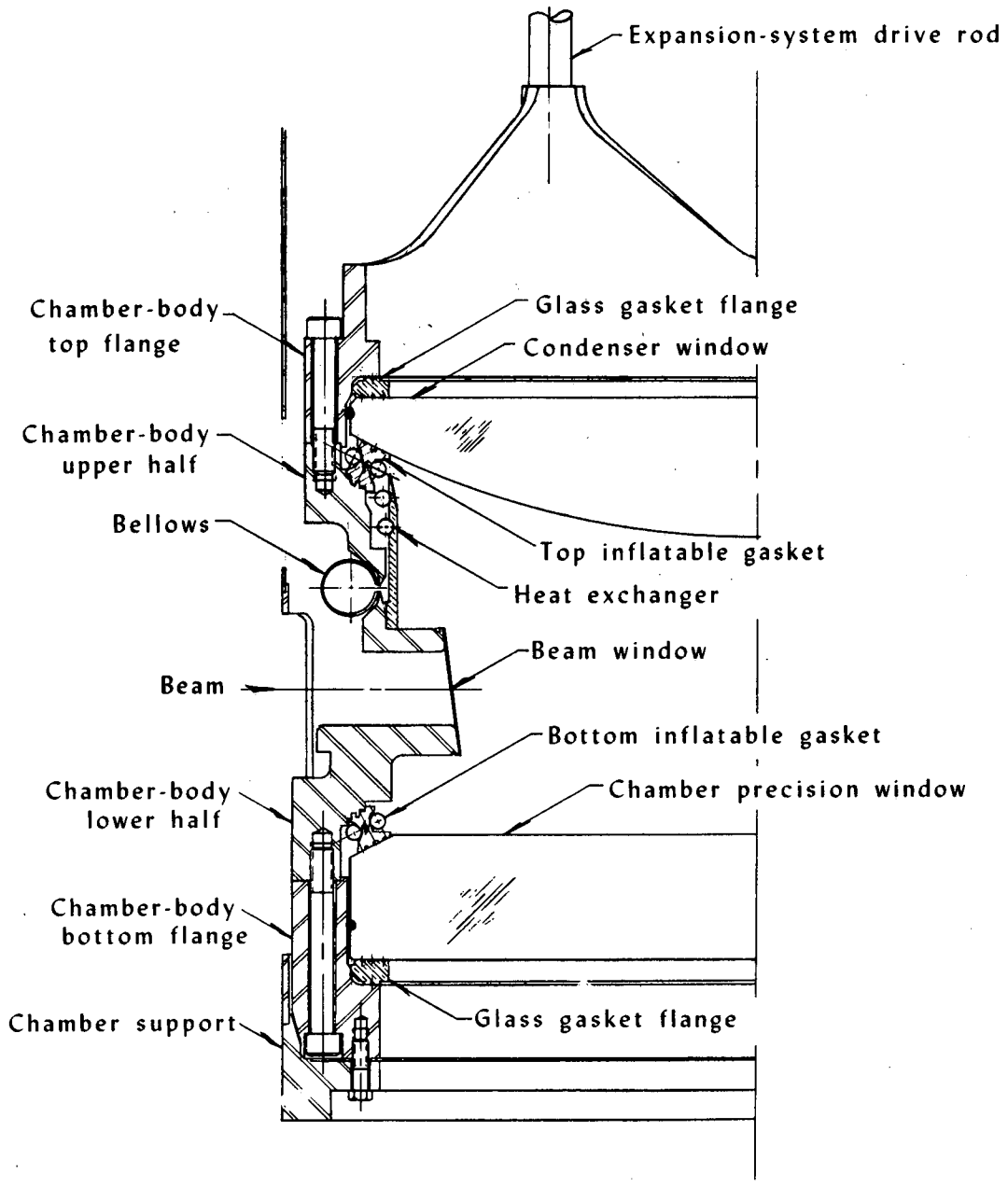

Fig. 1

MUB-2970



MUB-2971

Fig. 2

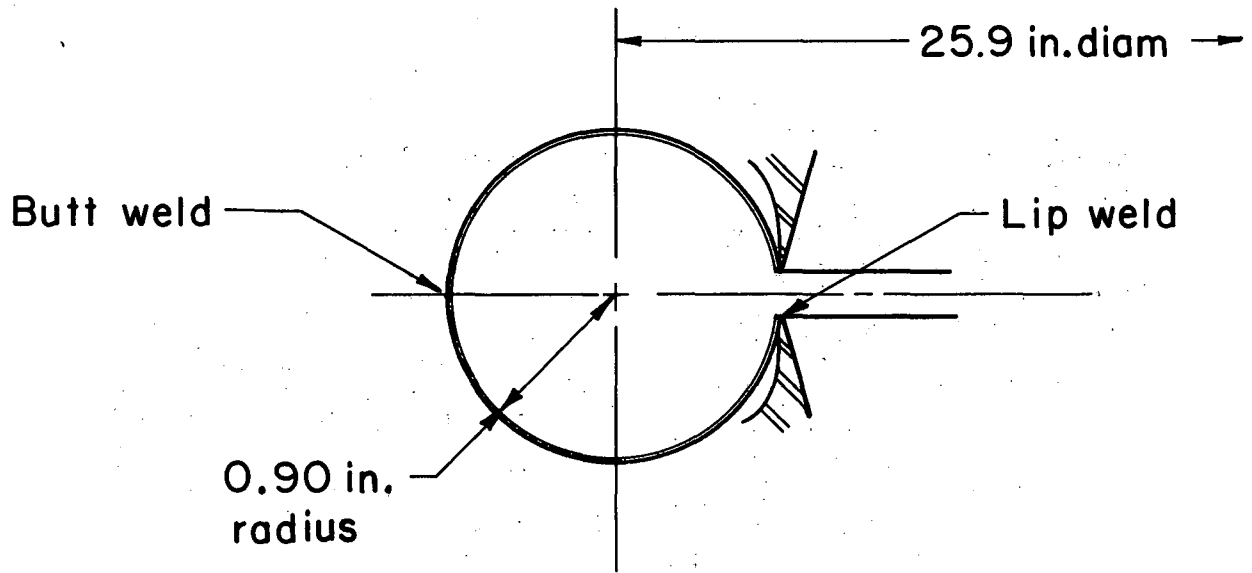

MUB-2972

Fig. 3.

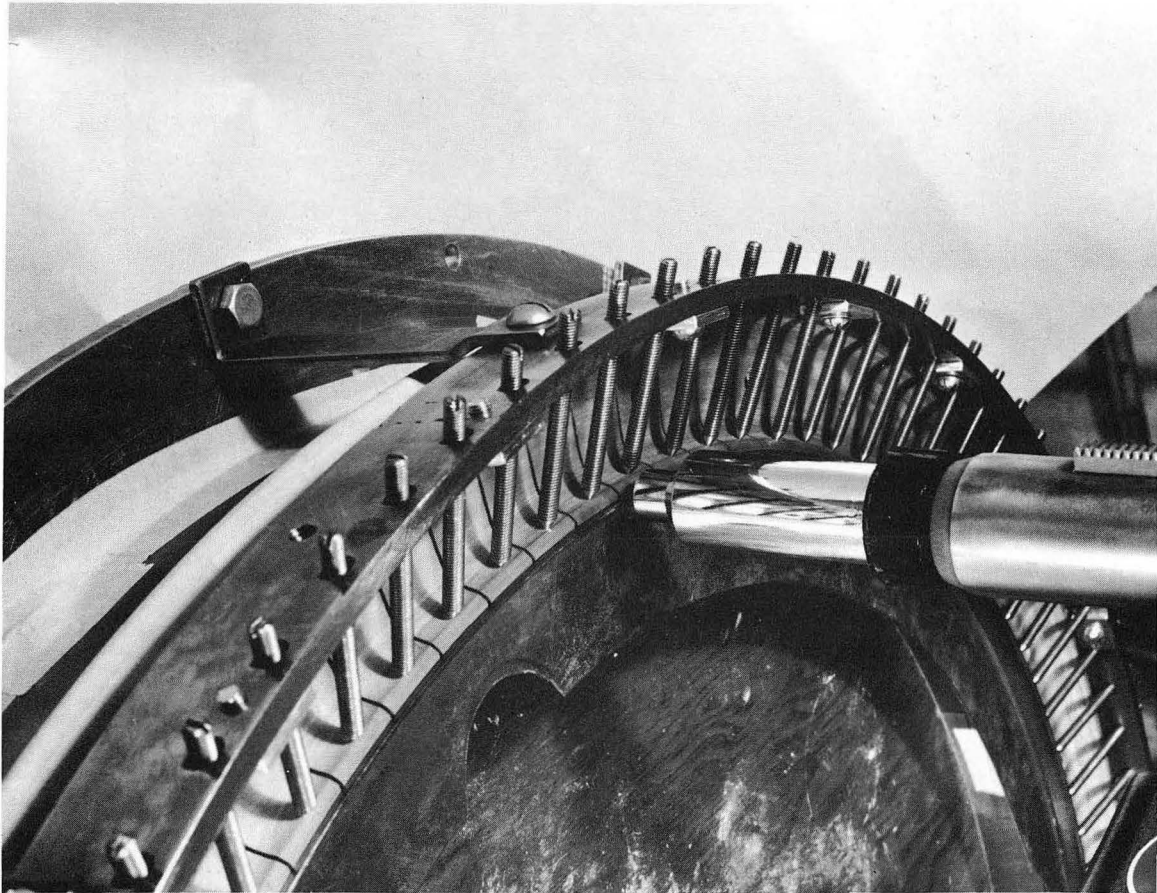

ZN-4340

Fig. 4.

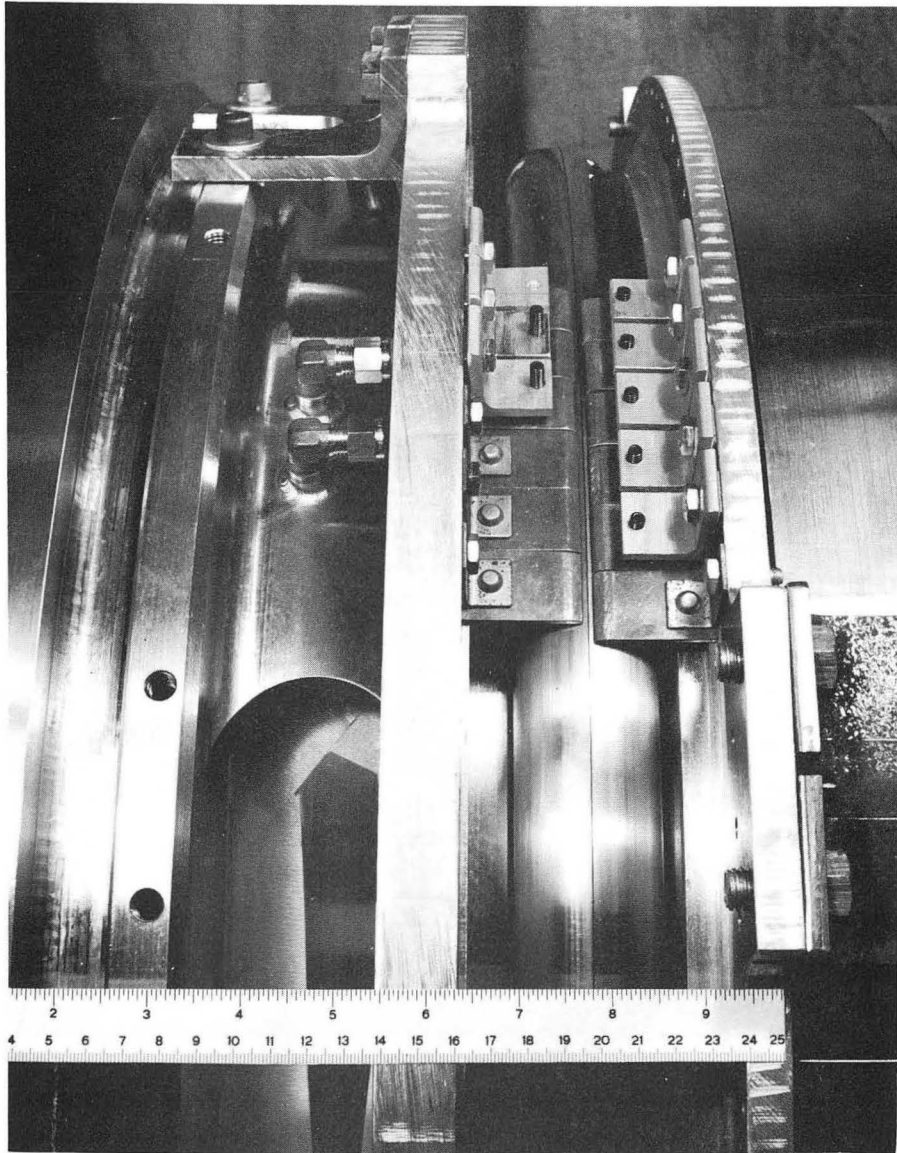

ZN-4341

Fig. 5

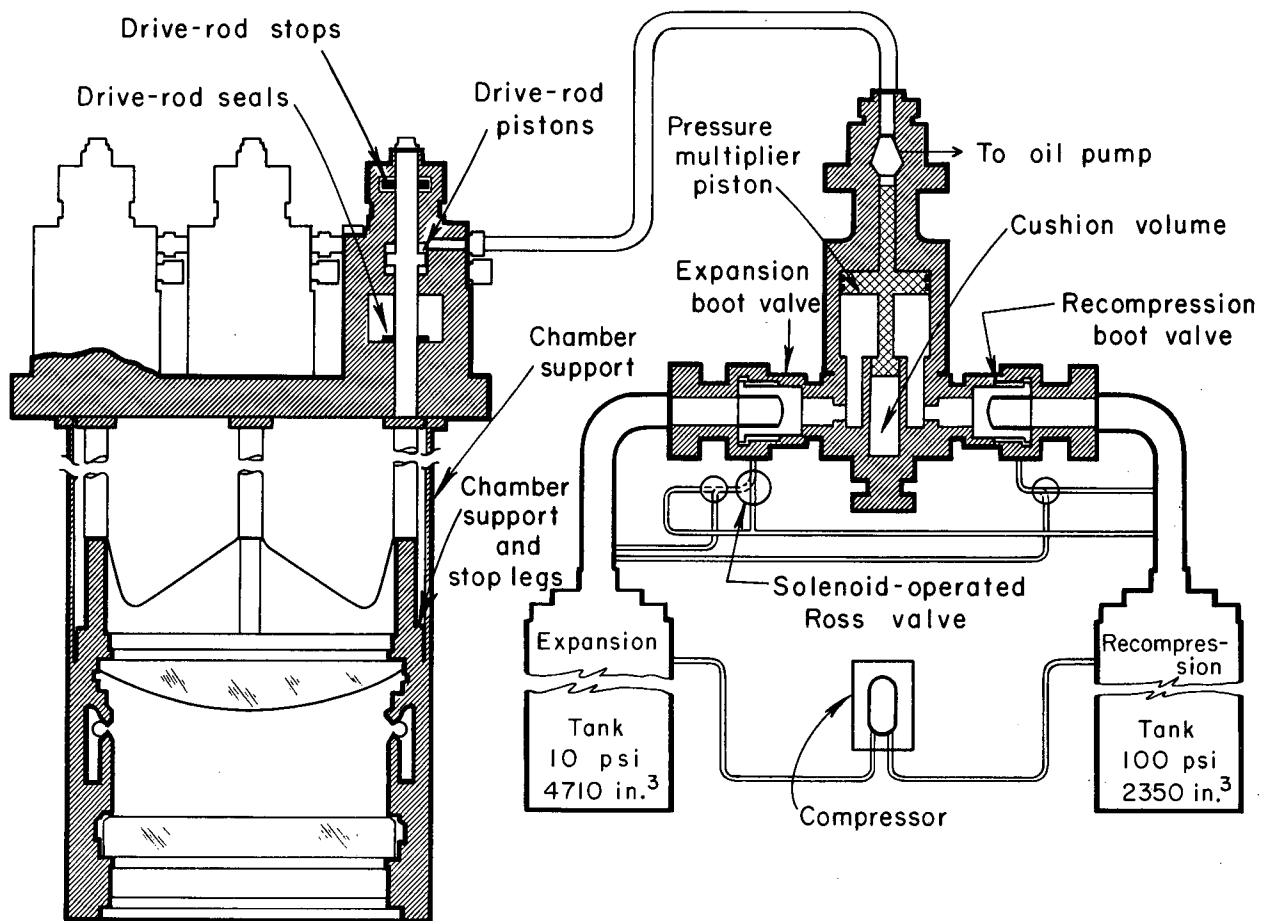

MUB-2975

Fig. 6

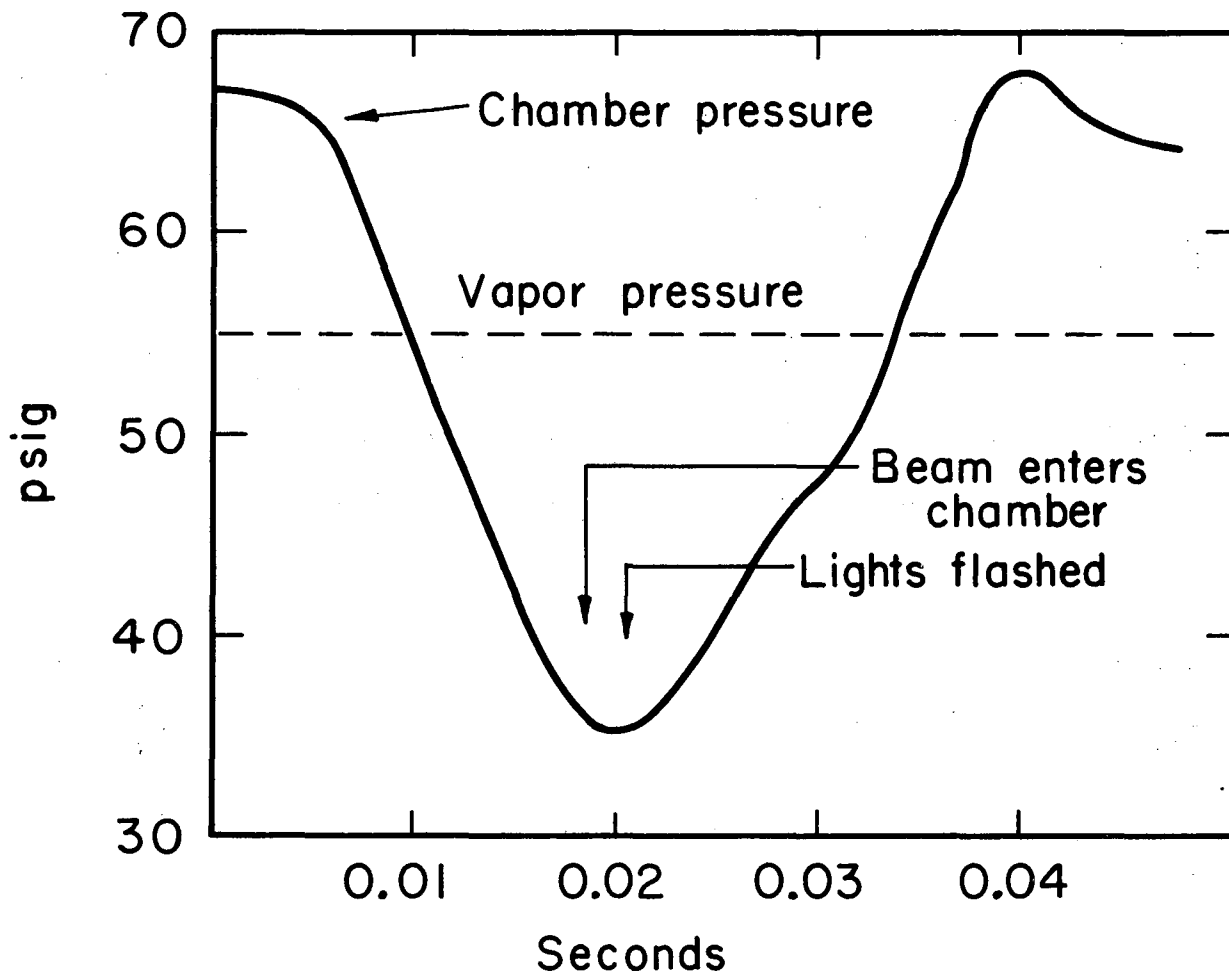

MUB-2976

Fig. 7

This report was prepared as an account of Government sponsored work. Neither the United States, nor the Commission, nor any person acting on behalf of the Commission:

- A. Makes any warranty or representation, expressed or implied, with respect to the accuracy, completeness, or usefulness of the information contained in this report, or that the use of any information, apparatus, method, or process disclosed in this report may not infringe privately owned rights; or
- B. Assumes any liabilities with respect to the use of, or for damages resulting from the use of any information, apparatus, method, or process disclosed in this report.

As used in the above, "person acting on behalf of the Commission" includes any employee or contractor of the Commission, or employee of such contractor, to the extent that such employee or contractor of the Commission, or employee of such contractor prepares, disseminates, or provides access to, any information pursuant to his employment or contract with the Commission, or his employment with such contractor.