

UC San Diego

SIO Reference

Title

Instrumentation for the measurement of the underwater light field and the determination of the optical properties of the sea

Permalink

<https://escholarship.org/uc/item/6jg5x3xk>

Author

Tyler, John E

Publication Date

1960-05-01

Visibility Laboratory
University of California
Scripps Institution of Oceanography
San Diego 52, California

INSTRUMENTATION FOR THE MEASUREMENT OF THE UNDERWATER
LIGHT FIELD AND THE DETERMINATION OF THE
OPTICAL PROPERTIES OF THE SEA

John E. Tyler

May 1960
Index Number NS 714-100

Bureau of Ships
Contract NObs-72092

SIO REFERENCE 60-24

Approved:

Approved for Distribution:

Seibert Q. Duntley
Seibert Q. Duntley, Director
Visibility Laboratory

Roger Revelle
Roger Revelle, Director
Scripps Institution of Oceanography

Instrumentation for the Measurement of the Underwater Lightfield
and the Determination of the Optical Properties of the Sea

In the application of radiometry to light measurements in the sea there are five important parameters which must be always kept in mind.

1. The directional distribution of the light being measured.
2. The bandwidth, or wavelength range included in the measurement.
3. The state of polarization of the radiation.
4. The magnitude of the radiant quantity measured, and
5. The direction of propagation of the radiant quantity being measured.

The measurement of some optical properties like the attenuation coefficient, and the volume scattering function requires artificial light which is strictly limited in its distribution, i.e., a collimated beam of light. Other quantities like irradiance, or spherical irradiance, and optical properties like the diffuse attenuation function K are determined for the light field as it exists in nature. Directional distribution is therefore under the control of the experimentalist only to the extent that in building instrumentation he must conform to the strict requirements of the defined quantities.

Bandwidth, on the other hand, is left almost entirely to the discretion of the experimentalist. The selection of bandwidth has been a vexing problem because it is not always clear what bandwidth should be used for a specific application. Even when known, it is often difficult to obtain phototube-filter combinations that will duplicate a desired bandwidth. Added to these difficulties is the fact that ocean water itself limits bandwidth¹² and in great depths may entirely control the bandwidth associated with the measurement. Current thought with respect to the selection of bandwidth is divided according to the requirements of individual problems.

The physical approach to the selection of bandwidth is to adopt a monochromatic criterion. Monochromatic measurements are the most generally useful since, once available, they can be applied to a variety of problems.

A second approach to bandwidth selection has been to match the instrumental bandwidth with the acceptance spectra or utilization spectra of the organism or image forming system being studied. The recent discovery of the accessory pigments¹⁵ effect in the photosynthetic action of certain plankton species has emphasized the importance of this approach.

A third approach to bandwidth selection has been the use of a broadband sharp cut-off filter which limits the bandwidth of the instrument to that region of the spectrum where the attenuation coefficients of the water are known to be lowest. Near-surface measurements can in this way be made to correspond closely in bandwidth to the deep measurements.

The state of polarization of the flux in the underwater light field is of course related to the state of polarization of the flux from the sky and to the subsequent scattering effects in the water. Recent measurements by Ivanoff and Waterman¹⁶ of the amount and direction of polarized light underwater indicate that polarization exists at considerable depth and should be given proper consideration in the design of instruments. Of the remaining two parameters, magnitude and direction, a word should be said about magnitude. In light measurements in the sea, instrument readings are related to radiant flux by a factor composed of circuit constants, which are generally designed to remain constant, plus an optical coupling factor which must remain constant for all aspects of the light field.

For an irradiance collector, for example, the optical coupling is stated by the cosine law.

$$I_{\theta} = I_0 \cos \theta$$

A collector plate with an error that becomes progressively worse as θ increases, will not yield readings which are directly proportional to irradiance for all sun angles because the direct rays from the sun, which would be the major determinant in the magnitude of the irradiance will be weighted differently at different angles. Similarly a spherical collector will not yield readings directly proportional the spherical irradiance for all light fields if the optical coupling factor is not a constant for every aspect of the sphere.

Optical equipment should obviously be carefully designed and tested to insure a constant coupling between collector and detector.

The physical quantities and properties which are most important for the optical documentation of the sea and of the underwater light field are reviewed below.

Radiance distribution	$N(Z, \theta, \phi)$
Attenuation coefficient	α
Volume scattering function	$\sigma(\theta)$
Irradiance	H
Scalar irradiance	h
Diffuse attenuation function	K
Distribution function	D
Reflectance function	R
Absorption coefficient	a
Total scattering coefficient	s
Path function	N_*
Beam transmittance	T

The first three can be regarded as having primary importance since the remaining nine can be derived from them.¹³ However, in the determination of these latter nine properties it is sometimes more convenient to make direct measurements and considerable attention has been given to specialized instrumentation for this purpose.

Radiance Distribution

The early exploratory measurements of radiance distribution underwater were made with instruments that were simple but ingenious and well designed for detecting the major features of radiance distribution underwater. The work of Pettersson and Johnson and Liljequist¹⁷ is of particular interest since it represents one of the major advances in the optical exploration of the ocean and focused attention on radiance distribution as an important parameter in optical oceanography.

The existence of "characteristic diffuse" light (or asymptotic radiance distribution) was deduced from these early measurements. A limited amount of data was also obtained on the influence of the light field above the water surface and the rate of change of radiance with depth.

Complete radiance distribution data for lake water under clear sunny and overcast lighting conditions was obtained at several depths by Tyler in 1957.⁶

These data are, of course, characteristic of optically identical water under the same lighting conditions any where in the world.

The instrumentation used by Tyler is shown in Figures 8 and 9. This instrument employs a gyrosyn compass for azimuth position information and a servo mechanism with positive propeller drive to maintain the azimuth position of the instrument underwater to better than 1° . The zenith angle is controlled by means of a synchronous motor and event marks which appear on a synchronously driven strip chart along with the data. The angular field is 6.6° , obtained by means of a Gershun tube. The instrument has a dual measuring head with two RCA 931-A multiplier phototubes each coupled to an amplifier with output proportional to the logarithm of the flux input.

A series of interesting studies has been made recently by Sasaki¹⁹ on the influence of sky lighting and depth on the radiance distribution in a horizontal plane. The instrument used by Sasaki is shown in Figure 11. This instrument employs a remotely indicated magnetic compass for azimuth position information. No azimuth control is provided and evidently is not necessary since the readings are taken at fixed angles from the compass heading which is always known.

The maximum radiance reading locates the vertical plane containing the sun. The angular field of view of the instrument is 10° , obtained by means of an optical system, and the flux is recorded by means of an RCA 931-A multiplier phototube and a microammeter. The zenith angle is fixed at 90° .

The instrument shown in Figure 12 was developed by Ivanoff¹⁶ and has been used by him for measurements of the polarization of underwater light. The instrument is also capable of radiance measurements in the horizontal plane and is of interest because of its simplicity and low cost. The instrument uses a Westaphot photocell connected to a galvanometer. Flux from the horizontal direction is directed to the cell by means of a mirror which scans the azimuth continuously. Azimuth position stability depends on a rudder.

Used for radiance measurements the continuous scan will generally record radiance as a wave form, the maximum of which would locate the vertical plane containing the sun. The length of the waveform would establish the equivalent of 360° in azimuth and the phase difference between two successive waveforms would be indicative of the stability of the azimuth position.

The zenith angle of observation of this instrument is also fixed at 90° .

Measurements of radiance distribution in the meridional plane have
recently been made by Jerlov and Fukuda in the stratified waters of
Gullmar Fjord. In this work the instrument was guided into the water along
a taut wire which also served to maintain a fixed azimuth orientation of the
measuring head. The resolving power of the instrument was 7.0° . The near-
surface experimental measurements are compared with computed results based
on a simple theory that neglects multiple scattering.

'Attenuation Coefficient'

Instruments for measuring the transmittance of a fixed path length of water have been in use in oceanography for a long time. Some of these instruments have undoubtedly come close to yielding the attenuation coefficient as defined in the section on theory, others have not. Rather than describe specific instruments we will put down here the essential optical characteristics of an α meter.

The basic principle of an α meter is contained in the equation

$$T = \frac{I}{I_0} = e^{-\alpha r}$$

Since transmittance (T) is obtained from the ratio of an air reading to a water reading it is important to utilize a beam of light which is not adversely affected by a change in index of refraction along its length. A suitable optical system is shown in Figure 13.

In this system the beam is cylindrically restricted to a constant cross section by imaging the field stop at the photocell with a magnification of one between the aperture stop and the image of the field stop. A change in index of refraction between the windows will under these circumstances cause a change in flux distribution on the surface of the detector but if the latter has uniform sensitivity over its surface, or constant coupling, no error will result.

The lamp must deliver a steady flux output during the measurement period and should be run on regulated voltage. Voltage control of the light output is not desirable because the flux output of the lamp is a function of the temperature of the container which may be quite different in water than in air. Probably the

most satisfactory method for controlling the light output is to provide another photocell near the lamp which monitors its flux output directly.

The inherent errors associated with the measurement of α have been discussed by Wills and Jones²⁰ and by Preisendorfer²¹. The major sources of error are perturbation of the light field as a result of the presence of the instrument and forward scattered light within the beam (which is unwanted). Preisendorfer has estimated that for a one meter instrument with a 1 cm diameter beam of light the error due to perturbation is 0.3% when it is used in water having $\alpha = .402/\text{m}$ and $\sigma_0 = 1.92/\text{meter steradian}$.

An α meter of advanced design for oceanographic work is in use by the Institute of Oceanology of the Academy of Sciences, U.S.S.R.²² The optical system of this 1 meter instrument is shown in Figure 4. The vacuum phototube (6) monitors the flux output from the lamp (1). Not shown is the modulator which modulates the direct beam and also the comparison beam. The two pulsating signals thus obtained are compared by means of a balance circuit and their ratio is plotted on an EPP-09 (Russian) strip chart recorder. This α -meter has calibration filters as well as color filters (16) which can be introduced into the beam from a remote control station. The instrument is built to withstand depths up to 200 meters and in addition has a sample tube that fits between the windows (9) and (10), which can be used for the measurement of samples taken at greater depths.

A great deal of specialized information is available in the literature on the variability of the total attenuation coefficient, α , with location, depth, wavelength, time and other parameters. Fig. 14a gives the wavelength variability of distilled water after Dawson and Hulburt,⁴⁰ Hulburt,⁴¹ and Curcio and Petty.⁴²

Volume Scattering Functions and Total Scattering Coefficient

The measurement of the volume scattering function is difficult. From equation 16 it can be seen that the measurement requires volume calibration as a function of angle as well as a determination of input irradiance. Because of the difficulties associated with these calibrations and perhaps because of a lack of interest in the real magnitude of the volume scattering function, there have been very few instruments specifically developed for this measurement.

Some instruments and techniques which have been described recently are applicable to the problem of measuring volume scattering function and these will be mentioned briefly.

The need for an in-situ type instrument with a controlled sample volume was recognized by Waldram²³ who was interested in light scattering in the atmosphere. Waldram developed a rotating stop which operated to maintain a constant sample volume as the angle for $\int (\theta)$ determination was changed. A stop of this design has been incorporated by Tyler²⁴ in a nephelometer for measurements of the volume scattering function in natural waters. Tyler's instrument shown in Figure 15 was designed for in situ measurements and has a cylindrically restricted beam of detectivity as well as a cylindrically restricted beam of light. Stray light is controlled by internally baffled lens shades which can be seen in Figure 15 and by the black trap which forms the background for the beam of detectivity. Experimental values of directional intensity, input irradiance and sample volume are used to compute the volume scattering function between 20° and 160° . These values can then be integrated to give the total scattering coefficient (see equation 21), and the forward and backward scattering coefficients.

More recently Dr. Jerlov³⁹ has developed the instrument shown in Figure 15a for studying the volume scattering function of ocean water. The detector in this instrument is fixed in a vertical position as shown in the figure. The lamp assembly can be released to turn slowly around the point p carrying a series of semicircularly arranged stops with it. These stops are designed to maintain a sample volume of fixed size at p. Relative values of the volume scattering function are obtained at 12 angles from 10° to 165° .

Measurements of the scattering of ocean water samples at a fixed angle have been found useful for characterizing waters of various types, and for studying the particle distribution in the ocean. Dr. Jerlov²⁵ has developed the equipment shown in Figure 17 for this purpose and in his investigations has used the premise that a direct correlation exists between his measurements at 45° from the beam and the total scattering coefficient.

The equipment consists of a modified Zeiss turbidity meter and a Pulfrich photometer set at the desired scattering angle. The volume of the sample is constant by virtue of the fact that it is contained in a glass cylinder which is immersed in water to reduce interface reflection.

Measurements are obtained by visually matching the scattered light to a comparison glass illuminated directly by the source. This is done in the split field of the Pulfrich photometer. Since the radiance of the comparison glass is directly proportional to the irradiance input to the sample, the readings can easily be converted into values of volume scattering functions at the specified angle by calibrating the instrument.

The instrument shown in Figure 17 was developed by Koslyaninov²⁶ and called a spectro-hydro nephelometer. This instrument has two voltage regulated light sources (5 and 15) one of which (5) irradiates the contained sample (1), the other irradiates a "milk" glass component (12,13,14,17) by means of the knife-edge mirror (8) and the mechanical attenuating arrangement (16). The scattered light is visually matched in the split field of the eye piece with the radiance of the milk glass. The scattering angle is changed by rotating the lamp assembly (5) around the vertical axis marked 6. Data is obtained from 1° to 150° and can be converted to values of the volume scattering functions by calibration procedures.

The instrument is equipped with six narrow band filters (10) and is used as well for α measurements by rotating the lamp 5 assembly to the position $\theta = 0^\circ$.

Figure 17a gives the volume scattering function for three samples of commercially available "distilled" water together with the computed values of the total scattering coefficients (Tyler⁴³). Figure 17b gives the average of 30 determinations of the relative volume scattering function obtained between Madeira and Gibraltar (Jerlov, unpublished).

Many of the design features adopted by Pritchard and Elliott³³ is their Recording Polar Nephelometer for atmospheric measurements could be directly applied to the problem of measuring volume scattering function in the ocean. Anyone who is seriously considering the development of instrumentation for this purpose would do well to consult their paper.

In addition to these instruments, two interesting proposals have been advanced for the direct measurement of the total scattering coefficient. The first by Buettell and Brewer²⁷, who, like Waldram, were working on atmospheric scattering, proposed a small Lambert emitter as a source which was to be viewed parallel to its surface at distance h above the surface. Their analysis demonstrates that when the absorption coefficient of the medium can be neglected the total scattering coefficient $s = 2 \pi h N / I_0$ where N is the measured radiance of the infinite path observed and I_0 is the initial intensity of the plate. Because of the relatively high absorption coefficients of water throughout the spectrum this method has limited application to the measurement of the scattering coefficient of sea water.

The second proposal advanced by Tyler,²⁸ utilizes a sample contained in a water tight glass sphere on a G. E. Spectrophotometer. Using the technique described the value obtained from the spectrophotometer is the total fraction of

scattered light from a collimated beam passing through a fixed volume. From this information the total scattering coefficient can be computed as a function of wavelength.

Irradiance

From Equation 3 it can be seen that in order to measure irradiance it is necessary to use a device which collects flux according to the cosine law

$$I_{\theta} = I_0 \cos \theta$$

Since photodetector surfaces do not collect flux in this manner, an optical collector must be provided. This usually consists of a diffusing glass or plastic disc which has been prepared or mounted so as to collect flux in accordance with the above cosine law. However, diffusing materials differ widely in their properties, and do not in general behave the same way when submerged as they do in air. Consequently design specifications are of limited value. The best procedure is to conduct a practical underwater test of the collecting properties of a plate as a function of the angle of incidence, using an axis tangent to the front surface of the plate. The source of light should be a uniform field of collimated light which more than floods the surface being tested. In this way the plate's properties can be brought to any desired degree of perfection.

Figure 18 illustrates a flat-plate collector which exhibited a total error of 2% in irradiance when used to measure a typical underwater light field.

Diffuse Attenuation Function and Reflectance Function

The measurement of these two properties is intimately associated with the measurement of irradiance (see Equations 38 and 34). Photoelectric instruments for measuring the downwelling flux and the upwelling flux have been in use at least since 1922 (Shelford and Gail).³⁴ However, measurements since that time have not all been made using a diffusing collector and the "extinction coefficients" obtained can in no sense be substituted for the diffuse attenuation coefficient as defined herein. In 1938 W.R.G. Atkins⁷ et. al. recommended the use of diffusing glass in measurements of "submarine illumination." This important recommendation makes much of the data published since that time valuable in approximating the value of K at various locations. Some of the diffusing plates used since 1938 may not have collected exactly according to the cosine law, (this would mean that the value of K obtained was a function of the directional distribution of the flux in the field as well as of the properties of the diffusing plate,) but the diffuse attenuation function, it will be remembered, is obtained from the ratio of two values obtained at two depths. The error due to an imperfect plate thus tends to cancel. If a diffusing plate of some kind was used, deep data and data taken on overcast days should be quite comparable to the diffuse attenuation function defined in Equation 38.

This reasoning does not hold, however, for measurements of the reflection function or the absorption coefficient. The directional distribution in the upper hemisphere underwater is quite different from that in the lower hemisphere, see Figure 19, and the proportionality factor which connects irradiance with the instrument reading will be quite different for the two cases thus leaving a significant residual error in the value of the reflectance function if the collector is imperfect.

An instrument suitable for the determination of the diffuse attenuation function K and the reflectance function R is shown in Figure 19.

Recently irradiance measuring instruments of advanced design have been developed by Boden, Kampa, and Snodgrass²⁹ at Scripps Institution of Oceanography and by Hubbard and Richardson³⁰ at Woods Hole Oceanographic Institute.

The former instrument employs interference type filters to isolate narrow spectral bands. Desaturation of the band because of large angles of incidence is avoided by a collimating tube located between the filter and the irradiance plate which limits the angle of incidence on the filter to 5° . See Figure 20. The instrument is equipped with a pressure transducer and can withstand pressures down to 600 meter depth. A series of remotely controlled aperture stops and an electronic circuit designed to yield readings proportional to the logarithm of the light flux give the instrument a wide range.

The instrument designed by Hubbard and Richardson employs a similar irradiance collector but the flux is sampled by means of a submersible monochromator shown in Figure 21. The data obtained is automatically corrected for the spectral sensitivity of the multiplier phototube as well as for the nonlinear dispersion of the monochromator. The recorded voltage is therefore directly proportional to the flux per unit wavelength.

Monochromatic data for the diffuse attenuation function is given in

Table 13.

TABLE 13

(Half bandwidth 10 mu)	K		Location and Source
	Depth	Depth	
	28 - 56 m	56 - 159 m	
400	.121/m		
420	.139	.0902/m	Lat. 39° 38' N
440	.133	.0820	Lon. 68° 42' W
460	.118	.0749	
480	.115	.0611	Hubbard ⁴⁴
500	.106	.0527	
520	.0995	.0545	
540	.107	.0806	
560	.105	.0852	
580	.110	.0908	
600	.107	.0933	

	Depth	Depth	
	150 - 250 m	122 - 198 m	
410	.065		
452	.053		
470	.051		Lat. 32° 40' N
489	.048		Lon. 117° 40' W
503	.047		
541	.064		
581		.081	Boden (Unpublished)

Scalar Irradiance (Spherical Irradiance)

The use of a spherical diffuse collector for measuring spherical irradiance was proposed in 1936 by Gershun⁴. Very little use has been made of this device in underwater light measurements. In current theory scalar irradiance is required for the determination of important optical properties such as the distribution functions and the absorption coefficient. Spherical irradiance can also be used to evaluate the K-functions and in this role has the advantage of being insensitive to tilting - a problem encountered sometimes with a horizontal irradiance collector.

In 1955 an instrument was described by Tyler³¹ which was used for the determination of K, R, and D functions in lake waters. This instrument is shown in Figure 22.

Absorption Coefficient

An instrument for the measurement of the absorption coefficient "a" of horizontally stratified water has been described by Tyler³². This instrument is based on the theoretical work of Preisendorfer⁵, and provides a direct method for the determination of "a" independent of the scattering of the water.

Path Function

No instrument has been developed for the measurement of path function underwater.

The instrument shown in Figure 20 has an accessory spherical irradiance collector and can be used to determine the absorption coefficient of large bodies of water.

Values of the reflectance function R_{∞} , the distribution function $D(-)$ and $D(+)$, the diffuse attenuation function $K(-)$ and the absorption coefficient a , computed for various depths from Tyler's⁶ radiance distribution data, are given in Table 14. The peak wavelength for this data is 480 mu and the half-band width 64 mu.

TABLE 14

Overcast Sky

Depth Meters	R_{∞}	$D(-)$	$D(+)$	$K(-)$ Per Meter	a Per Meter
6.1	.0221	1.29	2.77	.216	
18.3	.0250	1.33	2.82	.206	.144
30.5	.0266	1.33	2.77	.189	.119
42.8	.0279	1.34	2.79	.180	.123
55.0	.0258	1.34	2.94	.178	

Clear Sunny Sky

4.24	.0215	1.247	2.704	.129	
10.4	.0184	1.288	2.727	.153	.115
16.6	.0204	1.291	2.778	.174	.118
29.0	.0227	1.313	2.781	.169	.117
41.3	.0235	1.315	2.757	.165	.117
53.7	.0234	1.307	2.763	.158	.112
66.1	.0190	1.308	2.947	.154	

Applications

At the present time there appears to be three broad areas of application for light measurements in the ocean. These can be classified under the headings:

1. Descriptive Oceanography and other Geophysical Applications.
2. Photosynthesis and other Biological Phenomena.
3. Image Recording Equipment.

1. Descriptive Oceanography and other Geophysical Applications

The fact that certain geophysical features of the ocean are associated with characteristic optical properties has led to the use of optical measurements as a means for locating and describing these features.

Work of this type was undertaken at least as early as 1943 by Joseph and Wattenberg³⁶ who developed maps showing regional differences in light transmission of the Kattegat and of the area west of Lim Fjord.

More recently Joseph³⁷ has described specialized instrumentation which he has used to develop detailed cross sections and maps showing the correlation between important oceanographic features and the transmittance properties of the water.

Similar work has been done by Jerlov²⁵ who has developed particle distribution cross sections from scattering measurements.

Russian oceanographers are also using this technique and Koslyaninov²² has described a section through the North Pacific current by transmittance measurements.

Equipment of advanced design is being used in the United States for coastal and harbor surveys. This equipment called a "Water Clarity Meter" was designed by R. W. Austin⁴⁵ and is shown in Figure 24.

2. Photosynthesis and Other Biological Phenomena

The phytoplankton productivity of various areas of the ocean and the total standing crop at any location are intimately associated with the amount of light available for photosynthesis. It is well known that an increase in microorganisms is associated with a change in optical properties. Thus it is to be expected that correlation will be found between light measurements and nutrient concentration, or temperature.

3. Image Recording Equipment

In image recording equipment like the human eye, the camera, or television apparatus, a prime optical requisite for useful operation is adequate contrast from the object. The theoretical work of Duntley³⁵ and Preisendorfer^(loc.cit.) clearly shows the degenerative effect of the ocean environment on object contrast as it is seen by such equipment, and provides means for computing contrast under specified circumstances.

APPENDIX

Equations referenced in the text:

$$16. \quad \mathcal{J}(\theta) = \frac{J(\theta)}{H V}$$

$$21. \quad S = 2\pi \int_0^{\pi} \mathcal{J}(\theta) \sin \theta \, d\theta$$

$$3. \quad dH = N \cos \theta \, d\Omega$$

$$38. \quad K(Z, \pm) = - \frac{1}{H(Z, \pm)} \frac{dH(Z, \pm)}{dZ}$$

$$34. \quad R(Z, -) = \frac{H(Z, +)}{H(Z, -)}$$

Z depth

N radiance

H irradiance

J radiant intensity

V volume

S total scattering coefficient

$\mathcal{J}(\theta)$ volume scattering function

K diffuse attenuation function

R reflection function

REFERENCES

1. Preisendorfer, R. W.

See references below

2. LeNoble, Jacqueline Mlle.

Sur une application de la methode de Chandrasekhar a l'etude der
rayonnement diffuse dans les couches de brume.

Comptes Rendus Ac.Sc. 241 p. 567 (1955)

3. Preisendorfer, R. W.

Theoretical proof of the existance of characteristic diffuse light
in natural waters

Jour. Mar. Research, 18, pg. 1-9 (1959)

4. Gershun, A.

The light field, SVETOVOE, Moscow, 1936

Translated by Parry Moon and G. Timoshenko

Journ. of Math. Physics, 18 #2, p. 51-151 (1939)

5. Preisendorfer, R. W.

The divergence of the light field in optical media

S.I.O. Reference 58-41, (1957)

6. Tyler, J. R.

Radiance distribution as a function of depth in an underwater environment

Bull. S...O. of the University of California, Vol. 7, #5, pp. 363 (1960)

7. Atkins, W.R.G., G. L. Clarke, H. Pettersson, H. H. Poole, C. L. Utterback and
S. Angstrom

Jour. der Conseil Perm. Inter. pour l'Explor de la Mer

Vol. 13 pg. 37-57 (1938)

8. Preisendorfer, R. W.
Unified irradiance equations
S.I.O. Reference 58-43 (1957)
9. Preisendorfer, R. W.
Directly observable quantities for light fields in natural hydrosols
S.I.O. Reference 58-46 (1958)
10. Preisendorfer, R. W.
On the existence of characteristic diffuse light in natural waters
S.I.O. Reference 58-59 (1958)
11. Preisendorfer, R. W.
Some practical consequences of the asymptotic radiance hypothesis
S.I.O. Reference 58-60 (1958) ✓
12. Tyler, J. E.
Natural light as a monochromator
Limnology and Oceanography, Vol. IV, #1, pp. 102-105 (1959)
13. Tyler, J. E., W. H. Richardson, and R. W. Holmes
Method for obtaining the optical properties of large bodies of water
Jour. of Geophysical Research, Vol. 64, #6, pp. 667-673 (1959)
14. Preisendorfer, R. W.
Calculation of the path function and numerical example
Visibility Laboratory Report, S.I.O. Reference
15. Emerson, R., and R. Chalmers, and C. Cedarstraw
Some factors influencing the long-wave limit of photosynthesis
Proc. Nat. Acad. Sci. U.S., 43, pp. 133-43 (1957)
16. Invanoff, A., and J. H. Waterman
Factors, mainly depth and wavelength, affecting the degree of underwater light polarization, Jour. Mar. Research, Vol. 16, #3, pp. 283-307 (1958)

17. Pettersson, Hans

Measurements of the angular distribution of submarine light

Rapport et Proces-Verbaux Des Reunions du Conseil Permanent Int. Pour l'Explor. de la Mer, Vol. 108, pp. 9-12 (1938).

18. Johnson(Jerlov), N. G. and G. Liljequist

On the angular distribution of submarine daylight and on the total submarine illumination, Svenska Hydro. Bio. Komm Skrifter Ny. Serie Hydrografi, 14, pp. 3-15 (1938).

19. Sasake, Tadáyosky; S. Watanabe, G. Oshiba, and N. Okami

Measurements of the angular distribution of submarine daylight by means of a new instrument, Jour. of the Ocean. Soc. of Japan, Vol. 14 #2, pp. 47-52 (1958)

20. Wills, M. S., and D. Jones

The effect of forward scattered light on the readings of a light transmission meter

Admiralty Research Lab., Teddington, England, ACSIL/ADM/53-608. (1953)

21. Preisendorfer, R. W.

A general theory of perturbed light fields with applications to forward scattering effects in beam transmission measurements,

S.I.O. Reference 58-37 (1958)

22. Kozlyaninov, M.

Hydro optical research on the U.S.S. Vityaz.

Symposium given on board the Vityaz, (1958).

23. Waldram, J. M.

Measurement of the photopic properties of the upper atmosphere

Trans. Ill. Eng. Soc. (London) 10, pp. 147-188 (1945)

Q.J. 71 319-336 (1945)

24. Tyler, J. E.
Nephelometer for the measurement of volume scattering function in situ
J.O.S.A. 48, pp. 354-357 (1958)
25. Jerlov, N. G. (Johnson)
Particle distribution in the ocean
Reports of the Swedish Deep Sea Expedition, Vol. III, Physics and Chem. #3
Goteborg, 1947-48 (1953)
26. Koslyaninov, M. B.
New instrument for measuring optical property of sea water
Proceedings of the Institute of Oceanology, Academy of Science, U.S.S.R.
Jour. 25 (1957).
27. Beuttell, R. G., and A. W. Brewer
Instruments for the measurement of the visual range
J. Sci. Insts., 26, pp. 357-359 (1949)
28. Tyler, J. E.
Monochromatic measurement of the volume scattering of natural waters
J.O.S.A., Vol. 47, #8, pp. 745-747 (1957)
29. Boden, B. P., E. M. Kampa, and J. M. Snodgrass
Underwater daylight measurements in the Bay of Biscay
To be published.
30. Hubbard, C. J., and W. S. Richardson
Measurements of the spectrum of underwater light
Woods Hole Oceanographic Institution, Ref. No. 59-30 (1959)
31. Tyler, J. E.
Measurement of Light in the Sea
J.O.S.A., 45, 904(A) (1955)

32. Tyler, J. E.

An instrument for the measurement of the volume absorption coefficient of horizontally stratified water.

Contract NObs-72039, Task 4, Rpt. No. 5-4 (1960)

33. Pritchard, B. S., and W. G. Elliott

Two instruments for atmospheric optics measurements.

J.O.S.A., Vol. 50, #3, pp. 191-202 (1960).

34. Shelford, V. E., and F. W. Gail

A study of light penetration into sea water made with a Kunz photoelectric cell, with particular reference to the distribution of plants.

Publications Puget Sound Biol. Station, 3, pg. 141 (1922).

35. Duntley, S. Q.

The visibility of submerged objects

Final report, Visibility Laboratory, Massachusetts Institute of Technology, 31 August 1952.

36. Joseph, J., and H. Wattenberg

An investigation of the optical conditions in the sea

Hydrographic Department, Berlin (1944)

37. Joseph, J.

Extinction measurements to indicate distribution and transport of water masses

Proceedings UNESCO Symposium on Physical Oceanography, Tokyo, (1955).

38. Jerlov, N. G. and M. Fukuda
Radiance distribution in the upper layers of the sea
To be published (Tellus)
39. Jerlov, N. G.
Unpublished
40. Dawson, L. H. and E. O. Hulburt
The absorption of ultraviolet and visible light by water
JOSA, 24, 175-177 (1934)
41. Hulburt, E. O.
Optics of distilled and natural waters
JOSA, 35, 698-705 (1945)
42. Curcio, J. A. and C. C. Pettv
The near infrared absorption spectrum of liquid water
JOSA, 41, 302-304 (1951)
43. Tyler, J. E.
Measurement of the volume scattering function of hydrosols
JOSA, 50, 505A (1960)
44. Hubbard, C. J.
Measurement of the spectral distribution of light underwater
Woods Hole Oceanographic Institution, Ref. No. 58-6 (1958)
45. Austin, R. W.
Water clarity meter, operating and maintenance instructions
SIO Ref. No. 59-9 (1959)

- Figure 8 Underwater Radiance Photometer.⁶ The measuring head with its radiance tubes is on the right. The center box holds the tilt motor. The left box contains the gyrosyn compass and propeller-drive motor. The propeller can be seen through a hole in the damping fin on the left.
- Figure 9 Power supply and control panel for the underwater radiance photometer.
- Figure 10 (Not used).
- Figure 11 Drawing of instrument developed by Sasaki¹⁹ for radiance measurements in the horizontal plane.
- Figure 12 Drawing of instrument developed by Ivanoff¹⁶ for studies of polarization of light underwater.
- Figure 13 Optical system for measuring α , the total attenuation coefficient. (a) Details of the projection system; (b) Details of the detection system.
- Figure 14 Optical system of α -meter described by Koslyaninov.²²
- Figure 14a (No caption).
- Figure 15 Scattering meter designed by Tyler²⁴ for in situ measurements of $\sqrt{(\theta)}$.
- Figure 15a Scattering meter developed by Jerlov (unpublished) for in situ measurements of $\sqrt{(\theta)}$.
- Figure 16 Scattering meter developed by Jerlov²⁵ for contained samples.
- Figure 17 Scattering meter developed by Koslyaninov²⁶ for contained samples.
- Figure 17a Volume scattering function and total scattering coefficients for three samples of "distilled" water, for peak wavelength 522 m μ half-band width 56 m μ .
- Figure 17b Relative volume scattering function obtained by Jerlov in the North Atlantic near the entrance to the Mediterranean Sea for peak wavelength 465 m μ .
- Figure 18 Suggested design for an irradiance collector using a barrier-layer type photodetector.

- Figure 19 Distribution of flux from upper and lower hemispheres. Data shown is for overcast lighting at a depth of 42.8 m (from Tyler⁶) lower hemisphere data has been enlarged to exhibit the difference in shape. For sunny conditions the difference in shape would be still more pronounced.
- Figure 20 Photocell-type instrument designed by R. W. Austin (unpublished) for the determination of K and R. This instrument is equipped with a diffusing plastic sphere which replaces the upper irradiance plate thus making it possible to determine the distribution functions (D^{\pm}) and the absorption coefficient, (a). A pressure transducer, visible in Fig. 20a, gives accurate depth determination. A "deck" cell shown in Fig. 20b monitors the surface lighting.
- Figure 21 Instrument developed by Boden, Kampa, and Snodgrass.²⁹ The irradiance measuring head with amplifier below is on the right.
- Figure 22 Arrangement of the optics in the Hubbard submersible monochromator. The exit-slit mirror covers the upper half of the collimating lens so that the incoming flux passes under it to the prism. Irradiance is measured by utilizing an irradiance collector in front of the collimating lens on the left.
- Figure 23 Instrument for determining R, K, and D.
- Figure 24 The coastal survey meter designed by R. W. Austin measures both α and K.

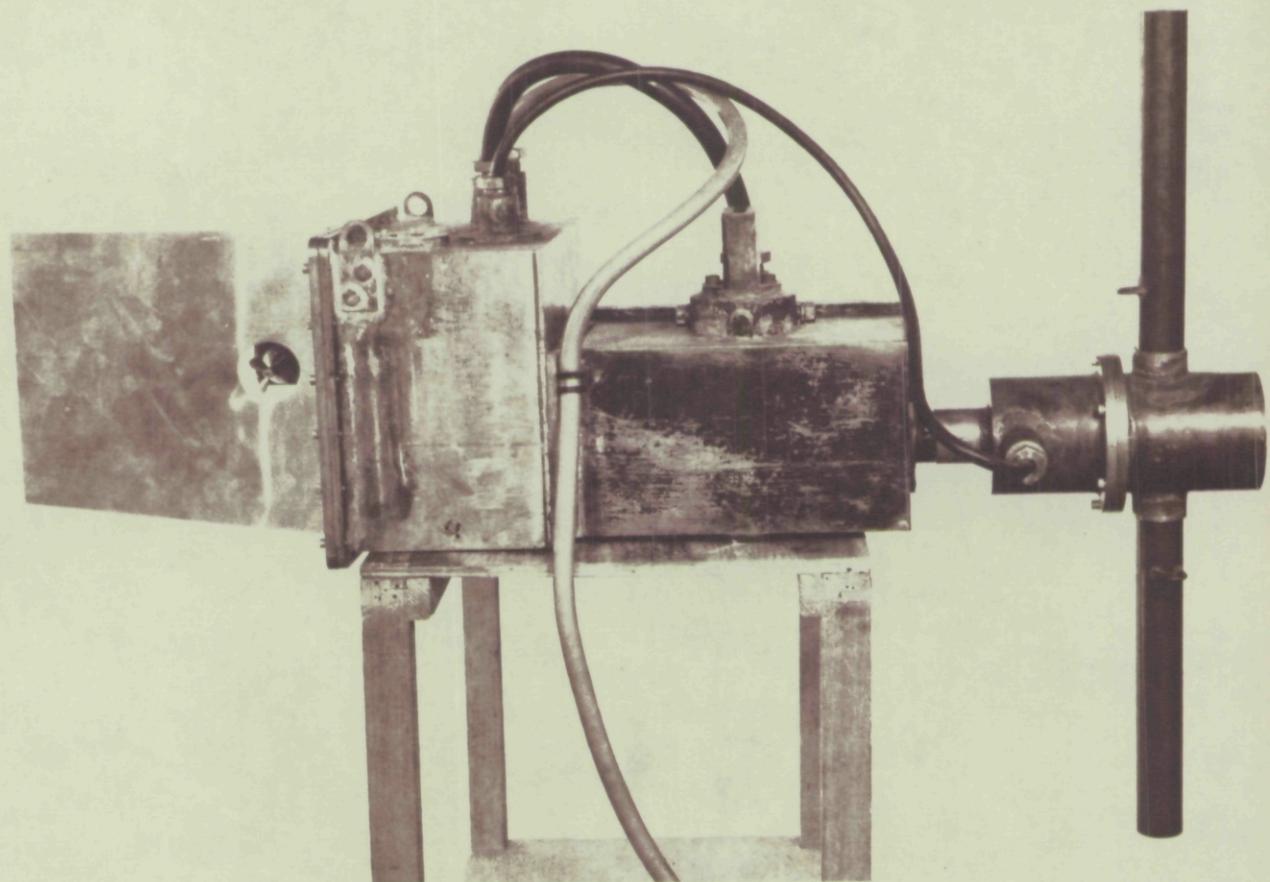

Figure 8

Underwater Radiance Photometer.⁶ The measuring head with its radiance tubes is on the right. The center box holds the tilt motor. The left box contains the gyrosyn compass and propeller-drive motor. The propeller can be seen through a hole in the damping fin on the left.

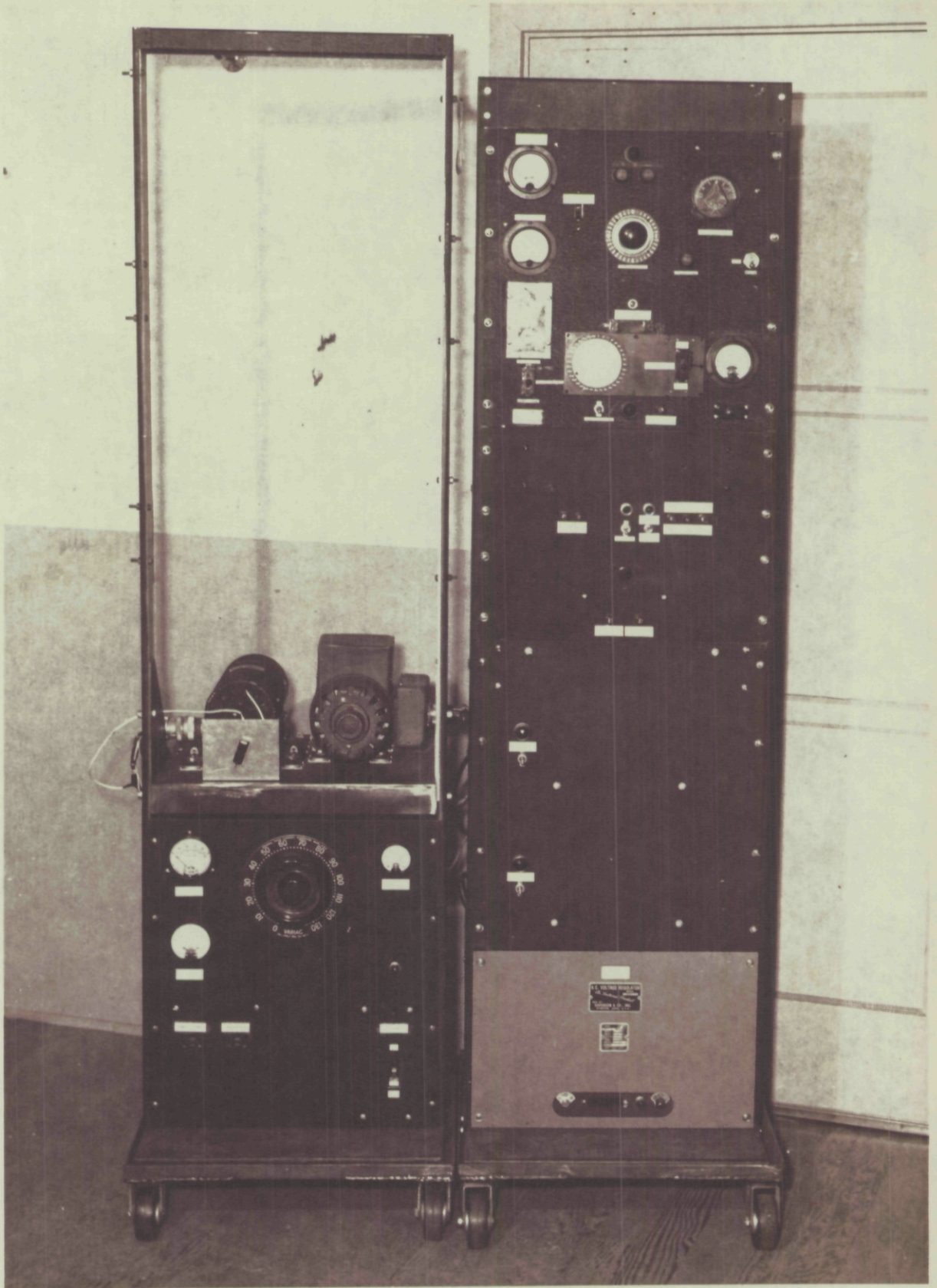

Figure 9

Power supply and control panel for the underwater radiance photometer

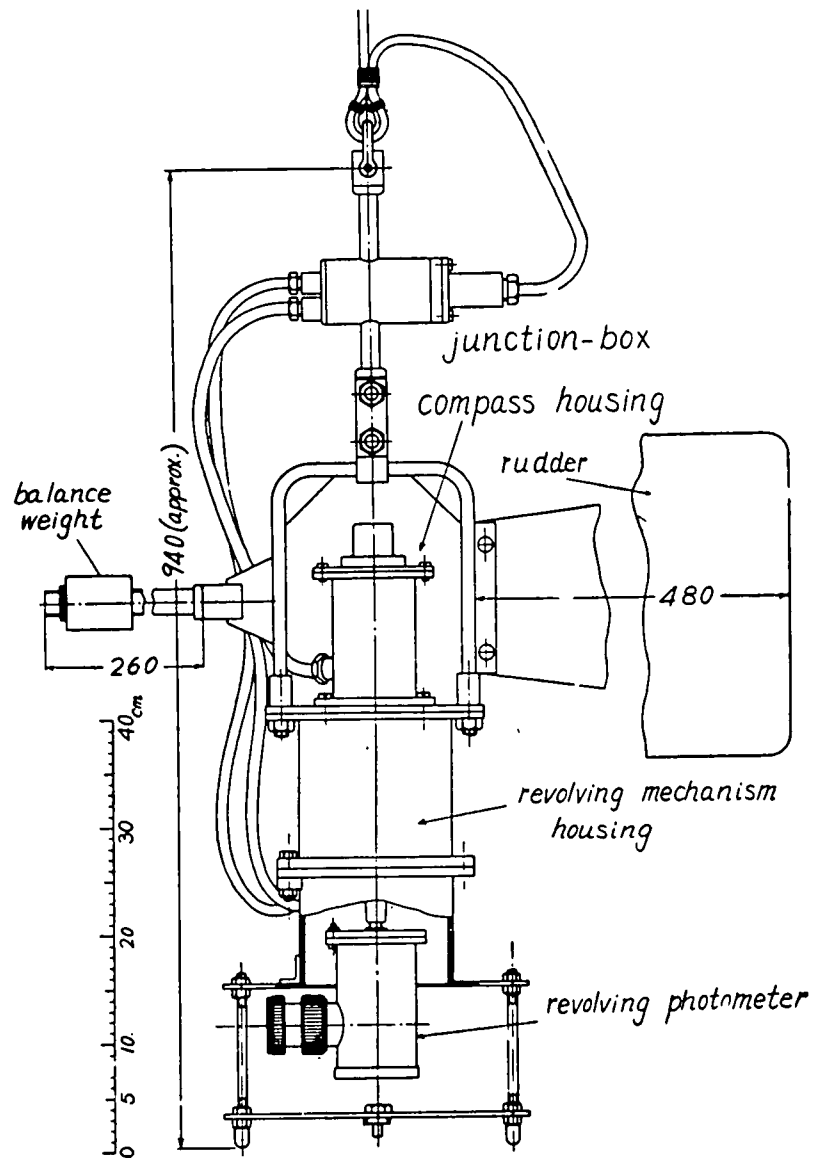

Figure 11

19

Drawing of instrument developed by Sasaki for radiance measurements in the horizontal plane

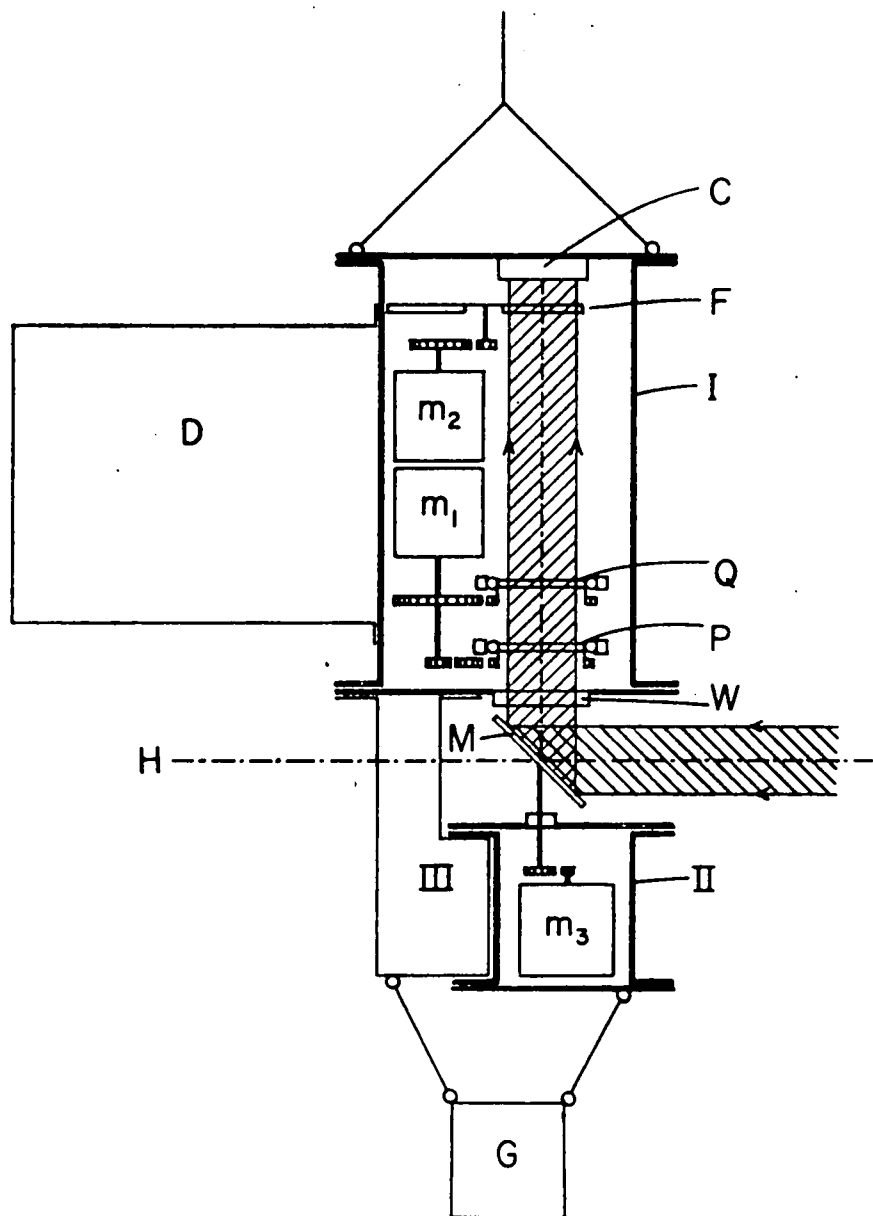
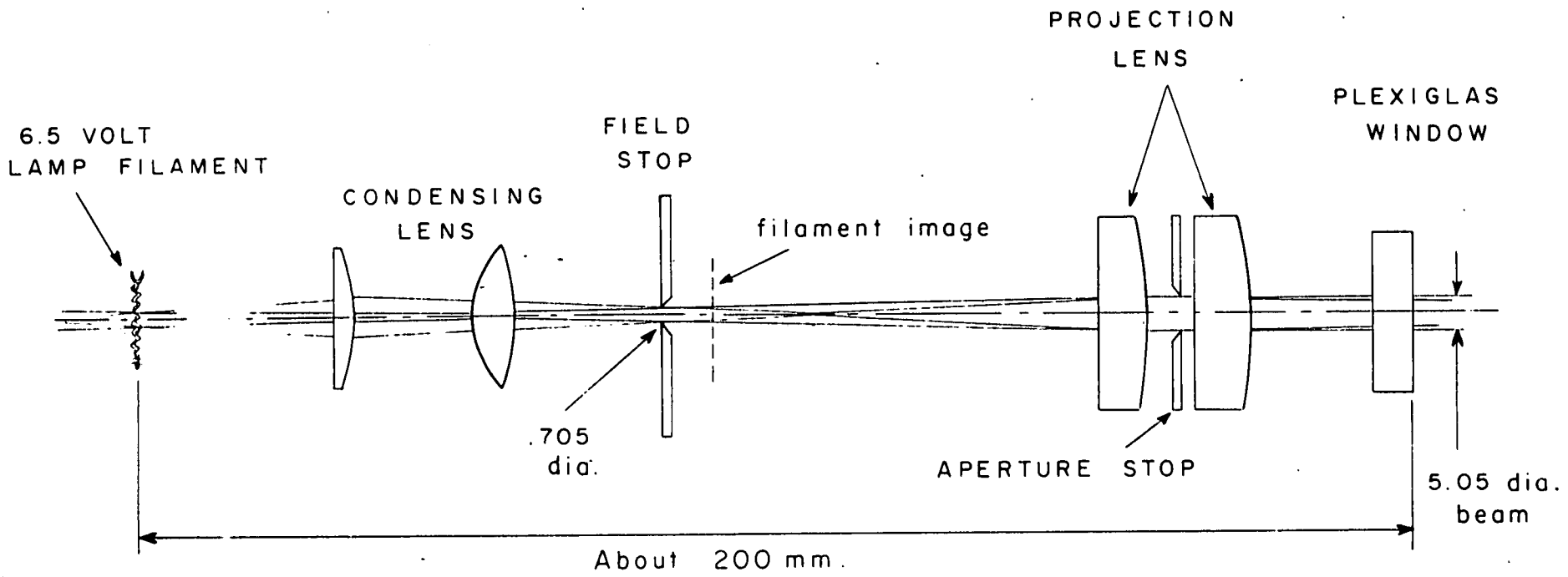

Figure 12

Drawing of instrument developed by Ivanoff¹⁶ for studies of polarization of light underwater



All dimensions in millimeters

PROJECTION UNIT
 OPTICAL SYSTEM FOR α METER

Figure 13(a)

Optical system for measuring α , the total attenuation coefficient

Details of the projection system

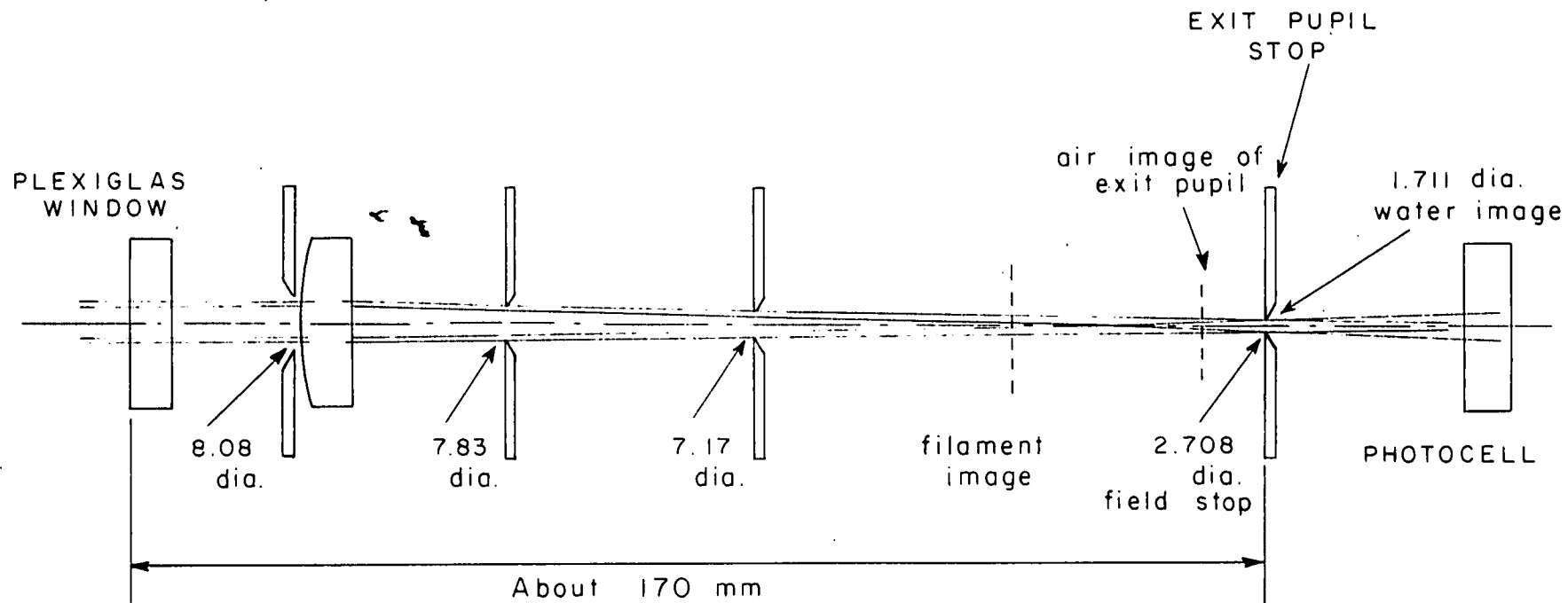

Scattering angle max. = 1°
 All dimensions in millimeters

RECEIVER UNIT

OPTICAL SYSTEM FOR α METER

Figure 13(b)

Optical system for measuring α , the total attenuation coefficient

Details of the detection system

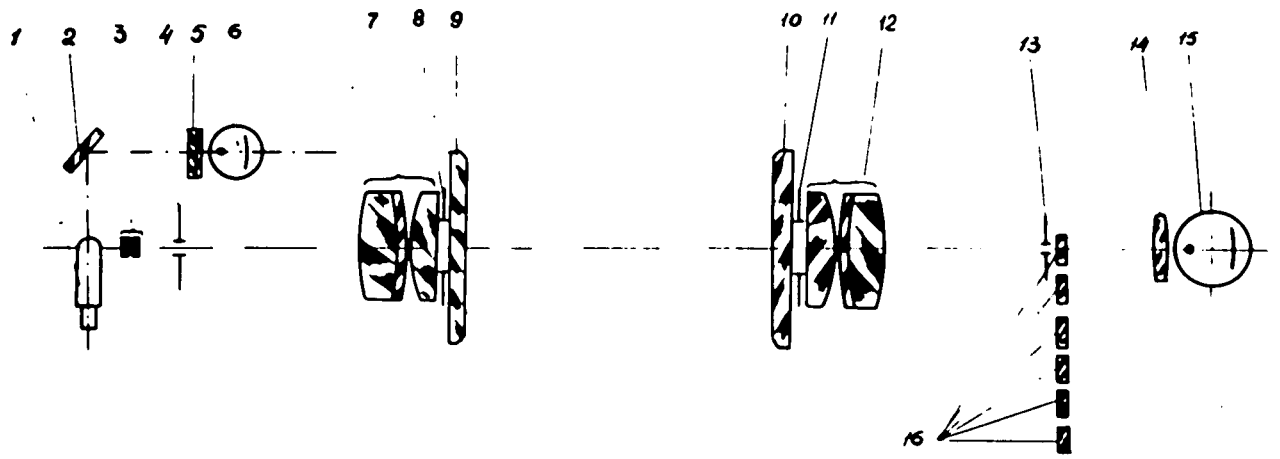

Figure 14

Optical system of α -meter described by Koslyaninov.²²

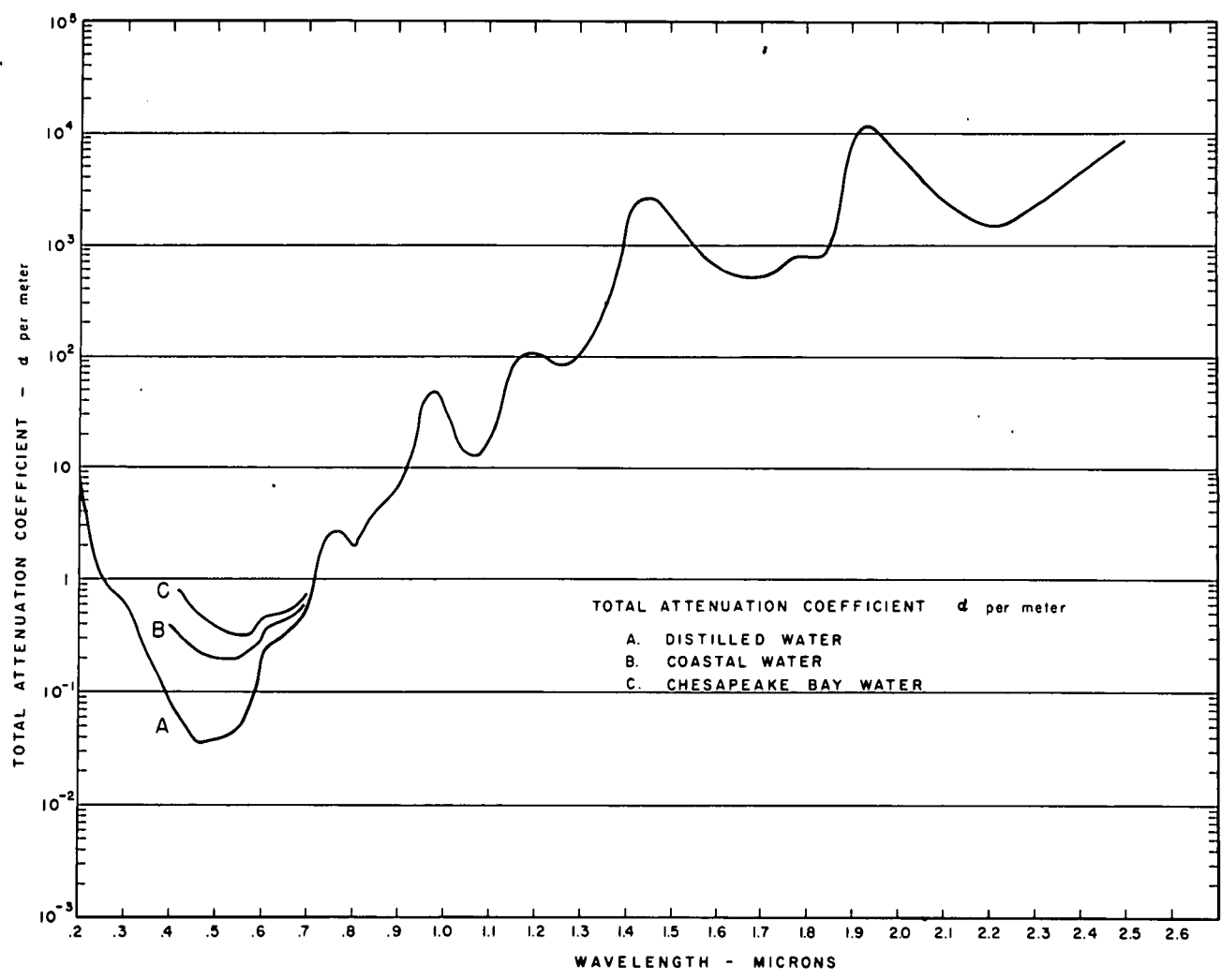

Figure 14(a)

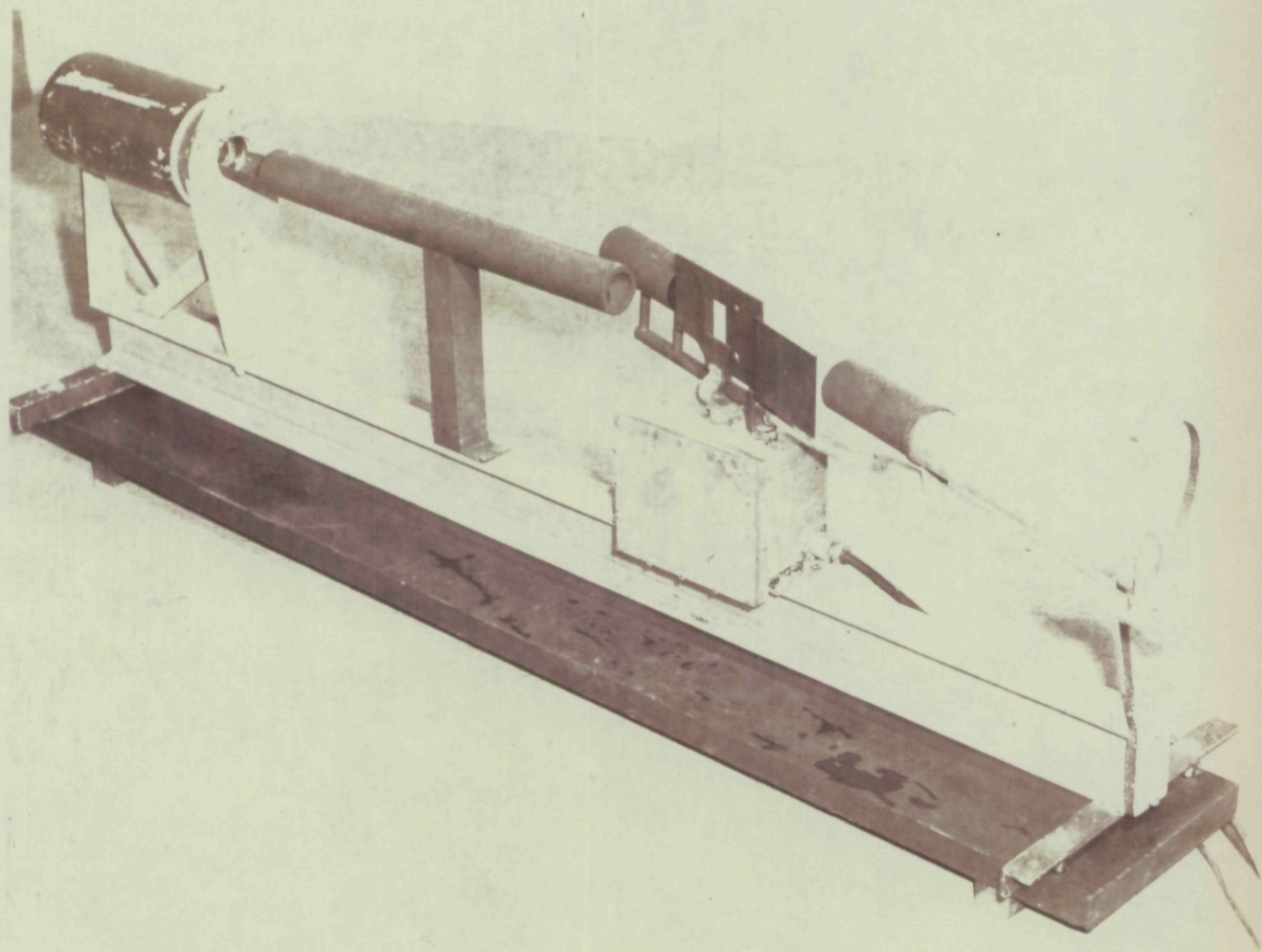
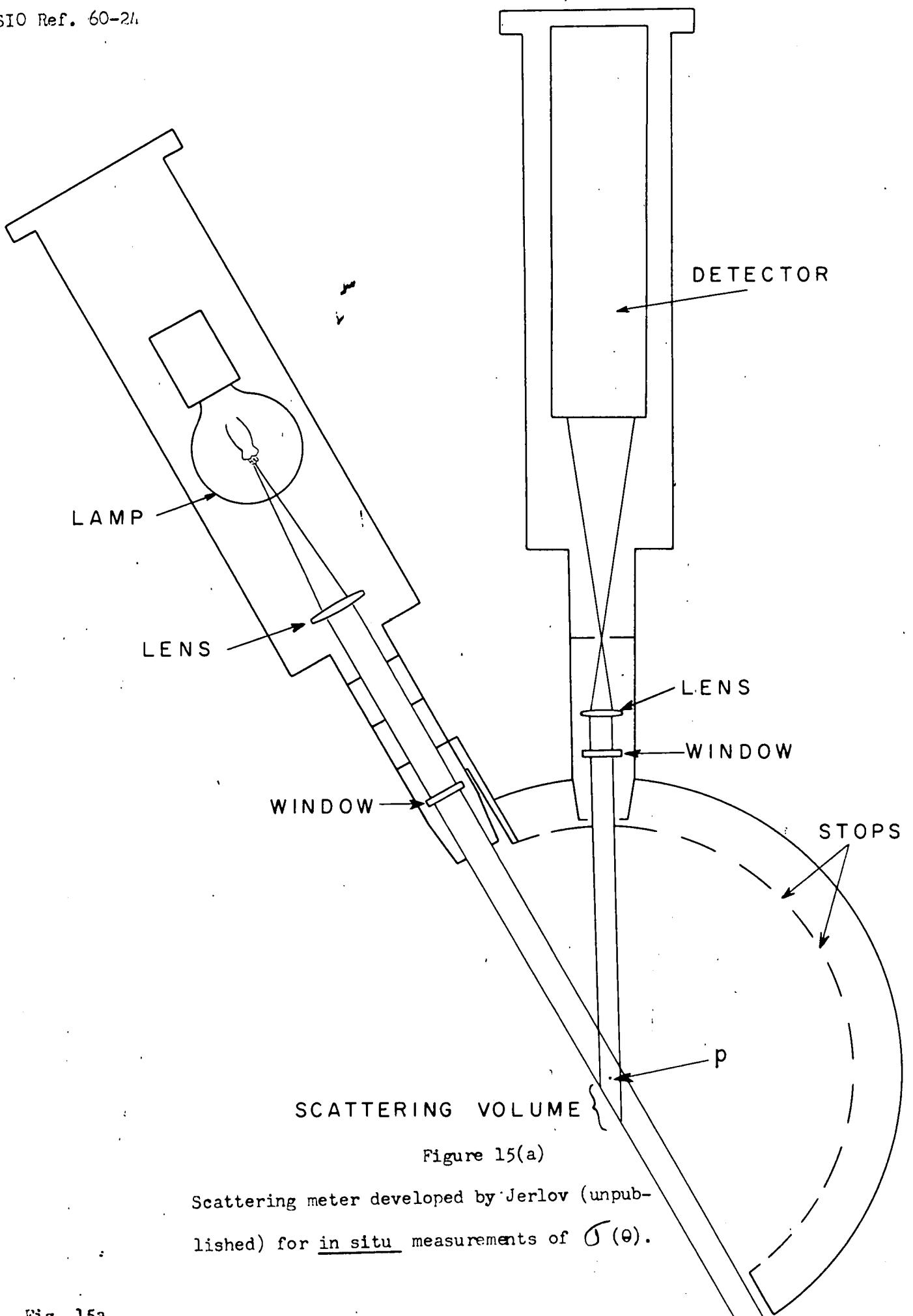

Figure 15

Scattering meter designed by Tyler²⁴ for in situ measurements
of $\Delta(\theta)$.



SCATTERING VOLUME

Figure 15(a)

Scattering meter developed by Jerlov (unpublished) for in situ measurements of $\sigma(\theta)$.

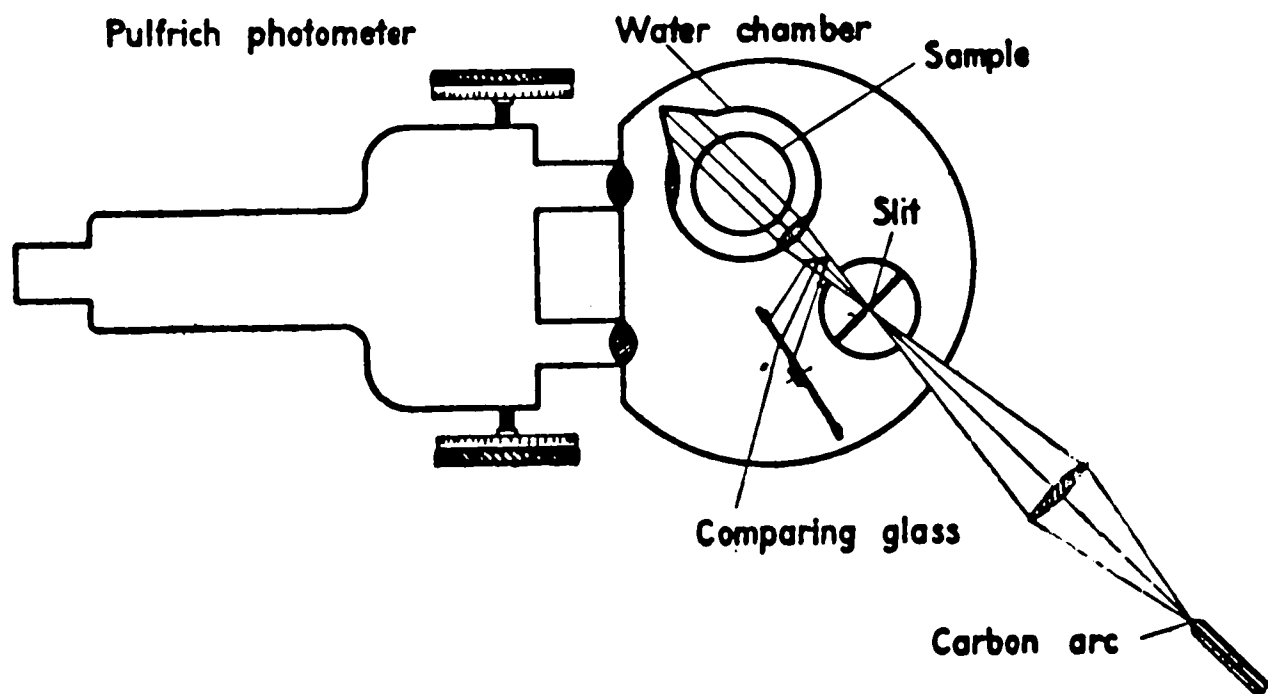

Figure 16

Scattering meter developed by Jerlov²⁵ for contained samples

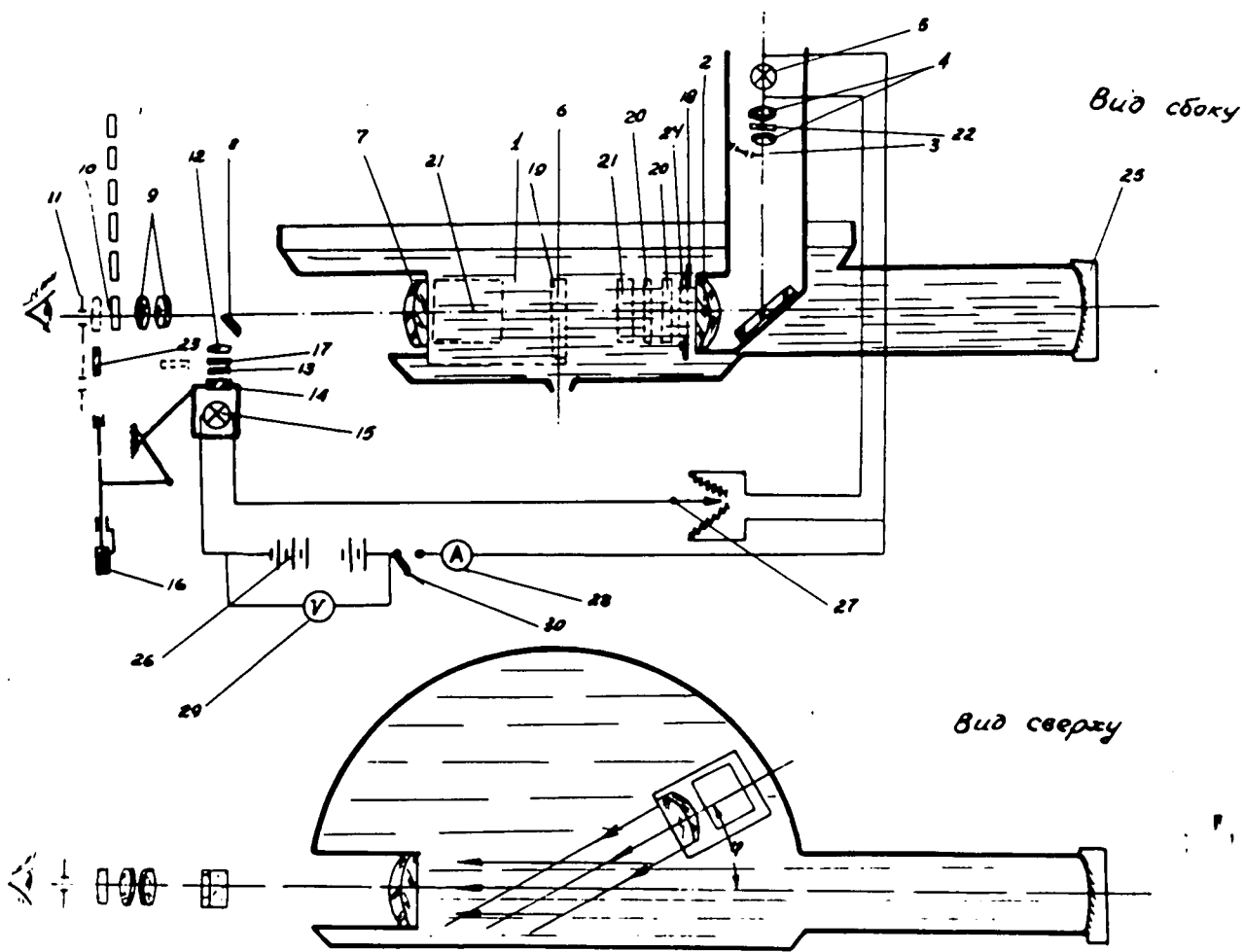

Figure 17

Scattering meter developed by Koslyaninov²⁶ for contained samples

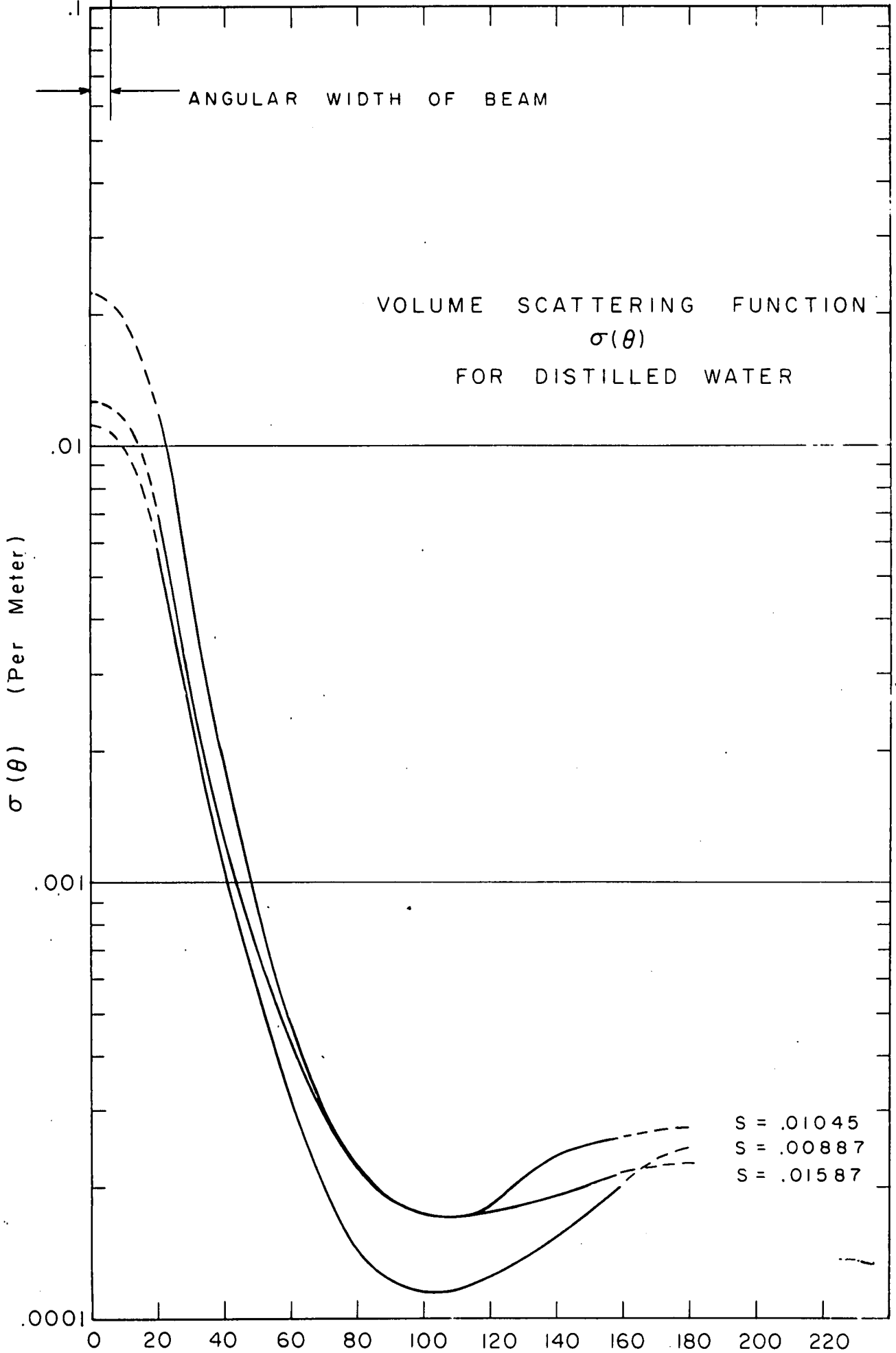

Figure 17 (a)

Volume scattering function and total scattering coefficients for three samples of "distilled" water, for peak wavelength 522 mu half-band width 56 mp.

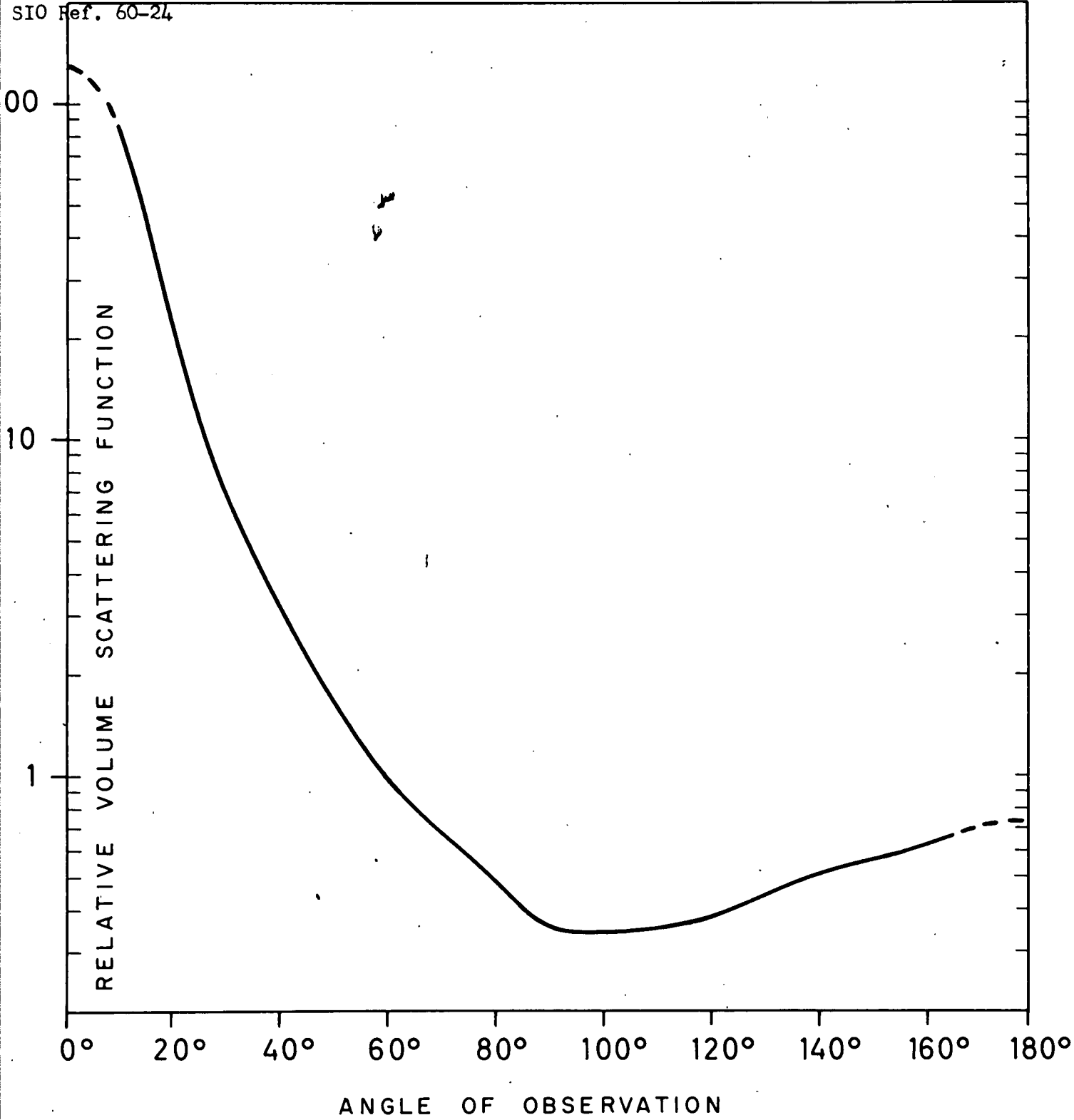
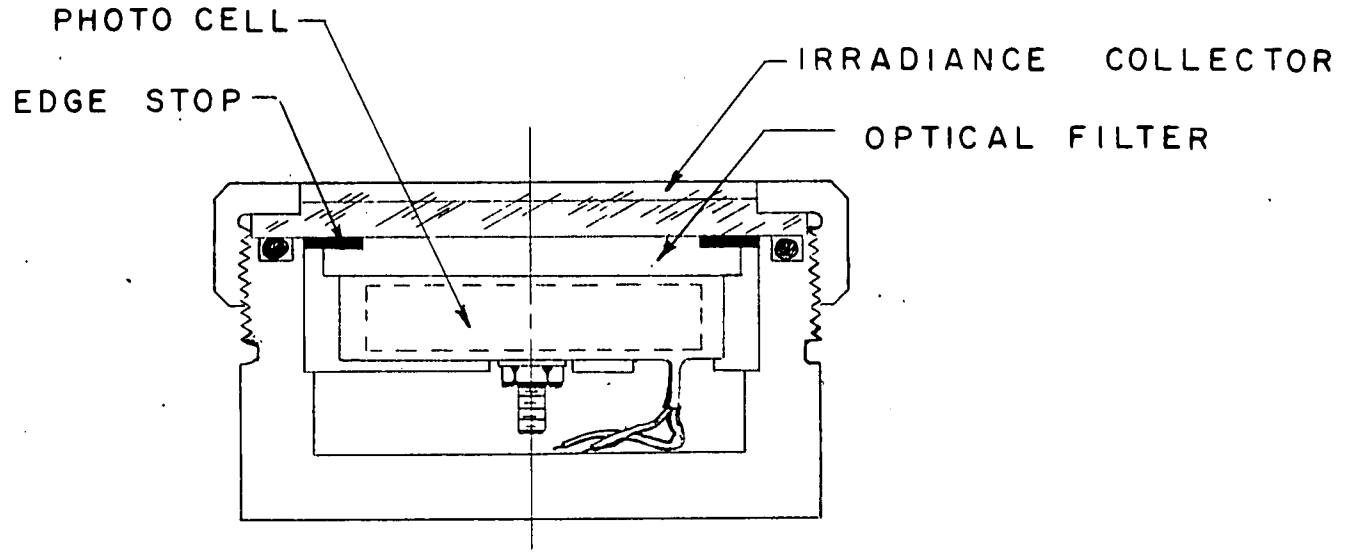

Figure 17 (b)

Fig. 17b Relative volume scattering function obtained by Jerlov in the North Atlantic near the entrance to the Mediterranean Sea for peak wavelength 465 mμ.



Recommended Optical Design Features of a Mounted Irradiance Collector.

Figure 18

Suggested design for an irradiance collector using a barrier-layer type photodetector

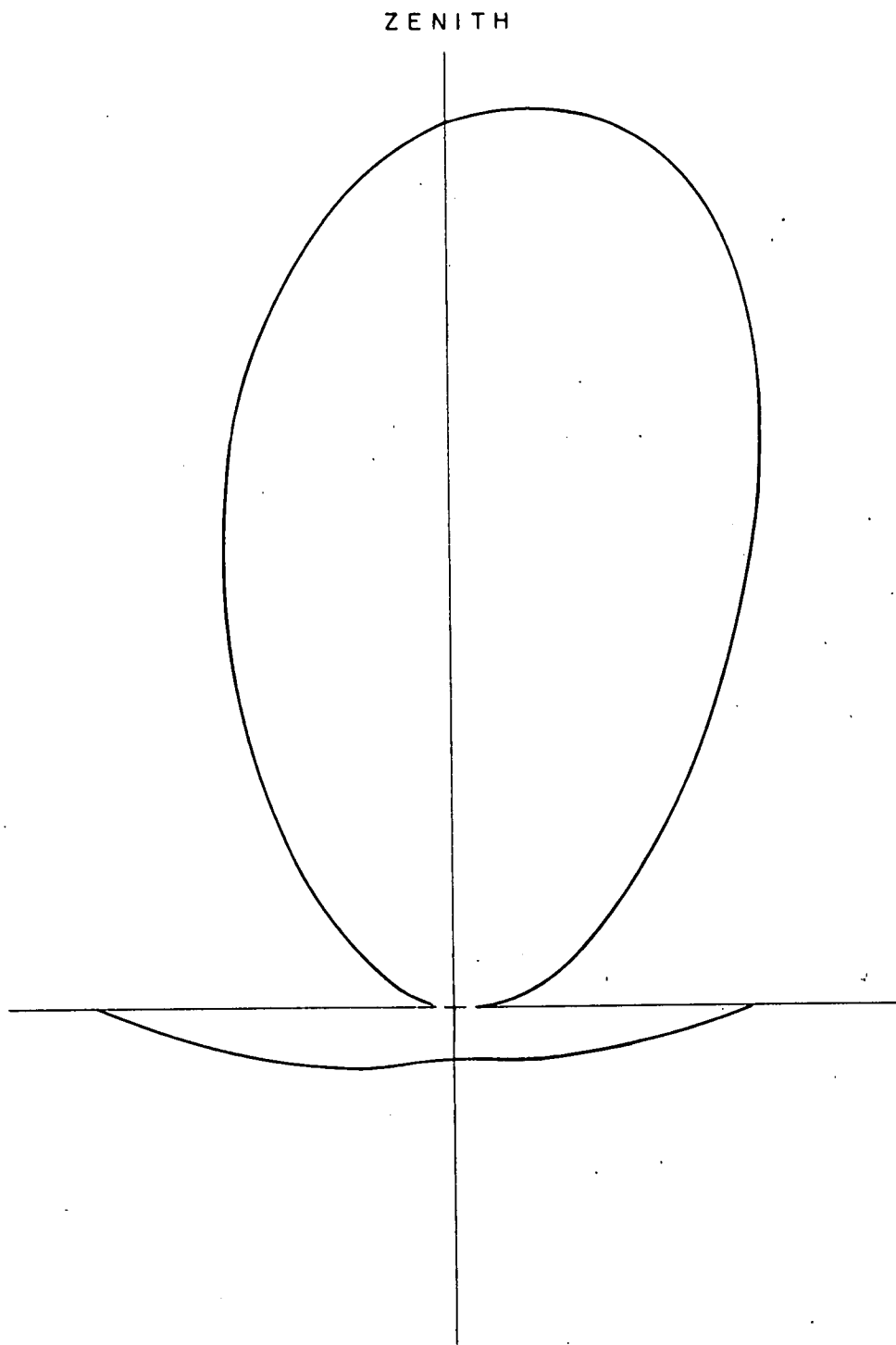

Figure 19

Distribution of flux from upper and lower hemispheres. Data shown is for overcast lighting at a depth of 42.8 m (from Tyler⁶) lower hemisphere data has been enlarged to exhibit the difference in shape. For sunny conditions the difference in shape would be still more pronounced.

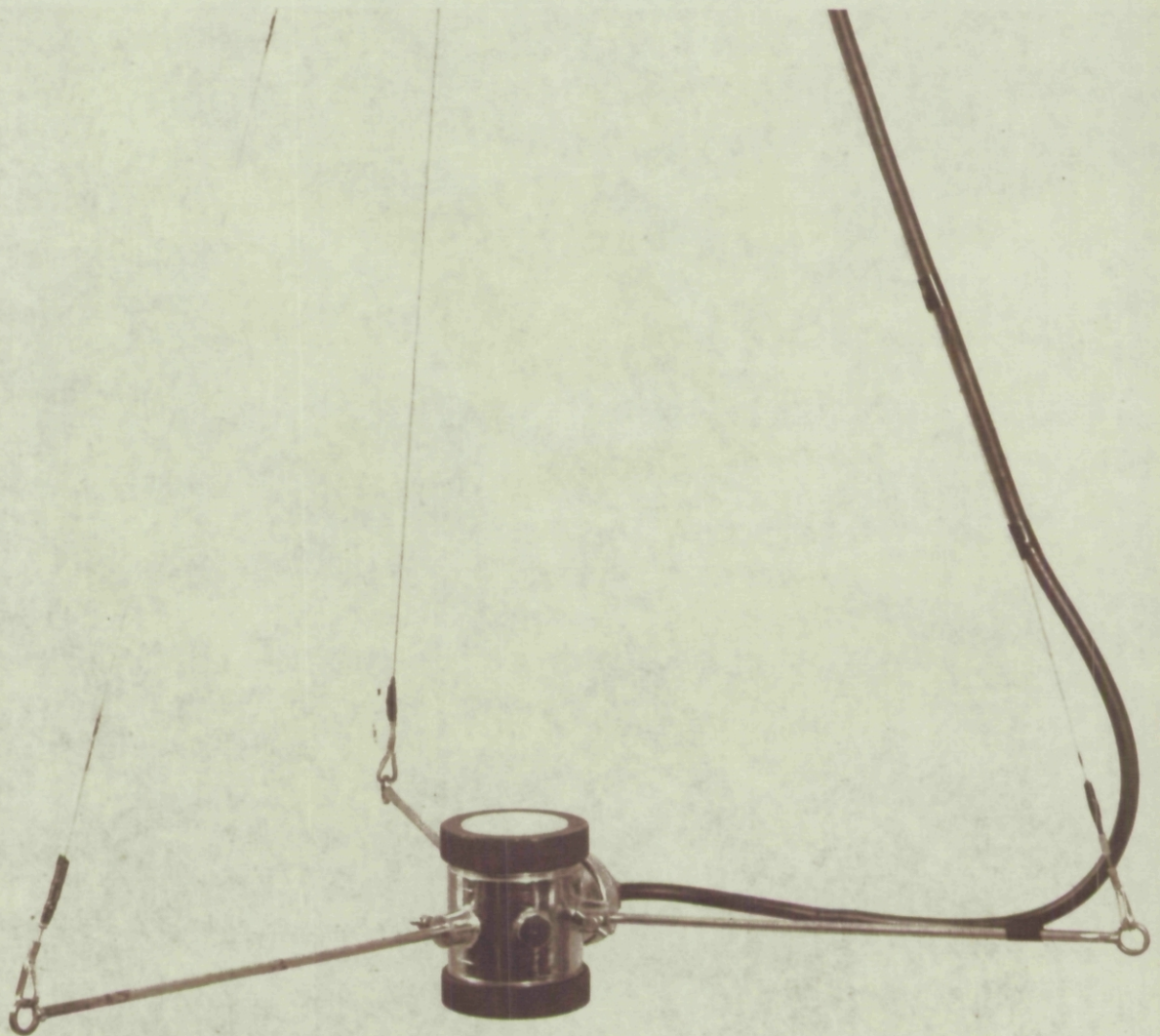

Figure 20

Photocell-type instrument designed by R. W. Austin (unpublished) for the determination of K and R . This instrument is equipped with a diffusing plastic sphere which replaces the upper irradiance plate thus making it possible to determine the distribution functions (D^{\pm}) and the absorption coefficient, (a) . A pressure transducer, visible in Fig. 20a, gives accurate depth determination. A "deck" cell shown in Fig. 20b monitors the surface lighting.

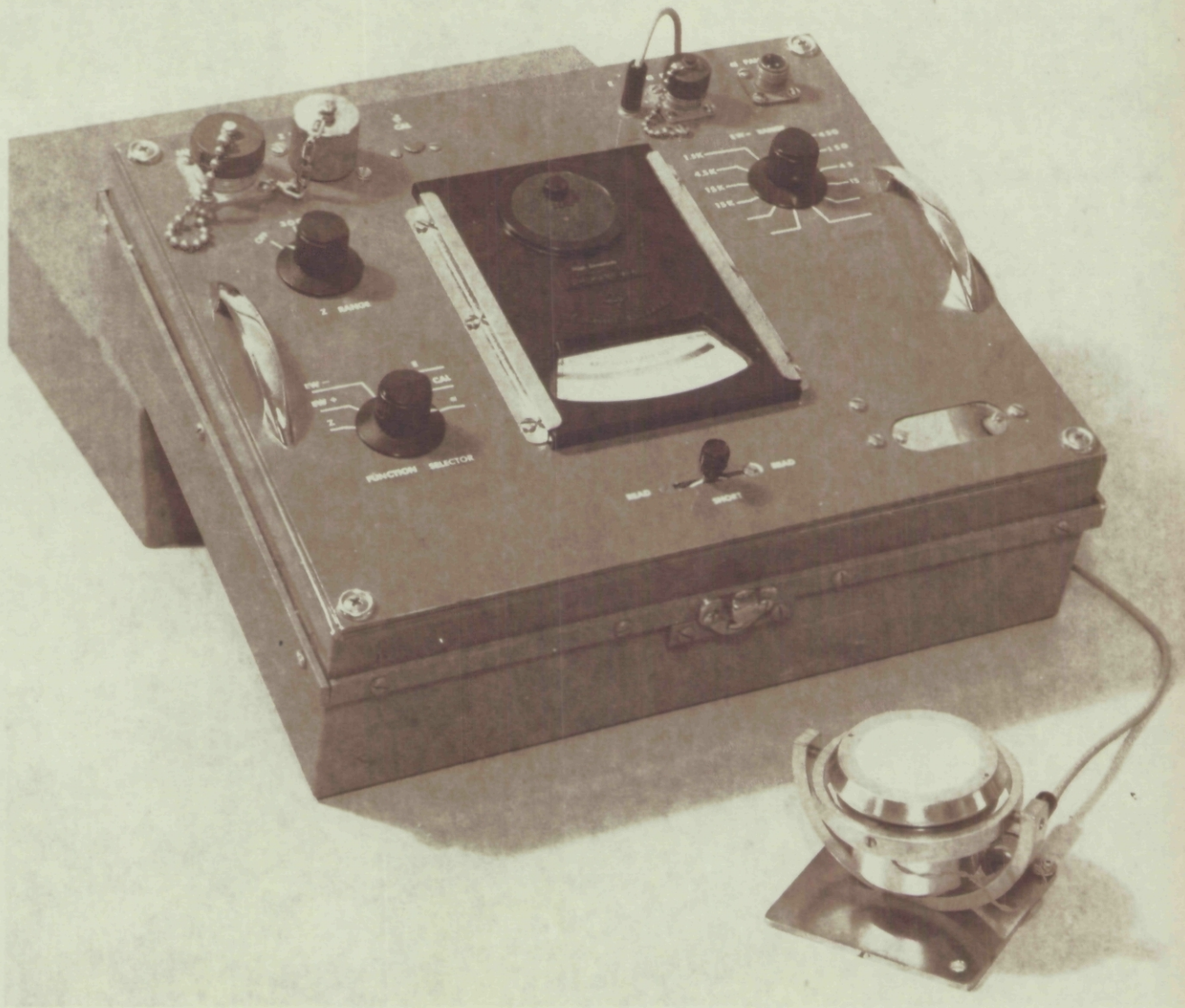
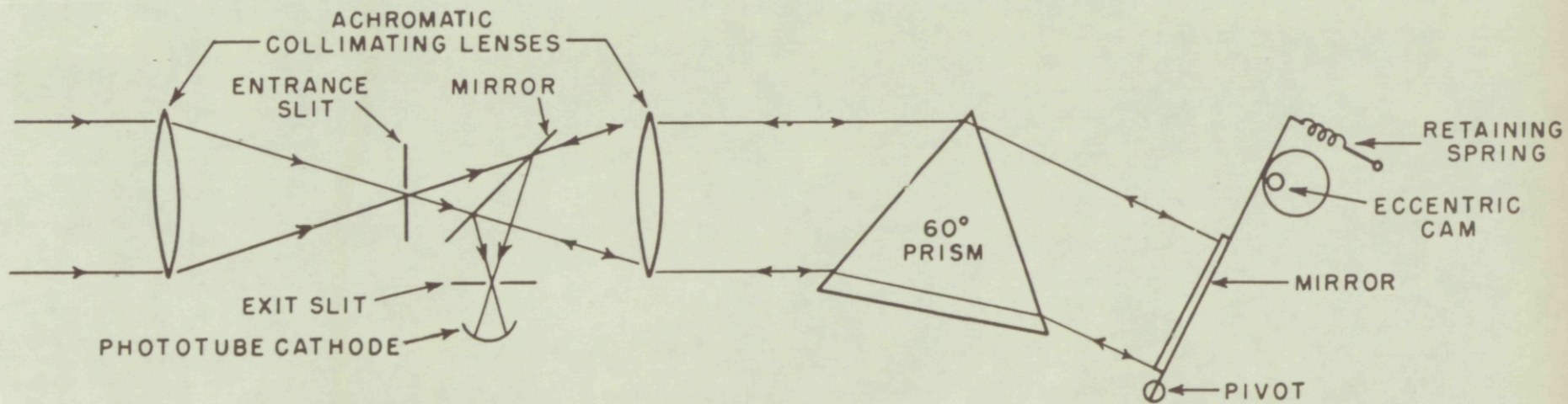

Figure 20 (b)



OPTICAL SYSTEM

Figure 22

Arrangement of the optics in the Hubbard submersible monochromator. The exit-slit mirror covers the upper half of the collimating lens so that the incoming flux passes under it to the prism. Irradiance is measured by utilizing an irradiance collector in front of the collimating lens on the left.

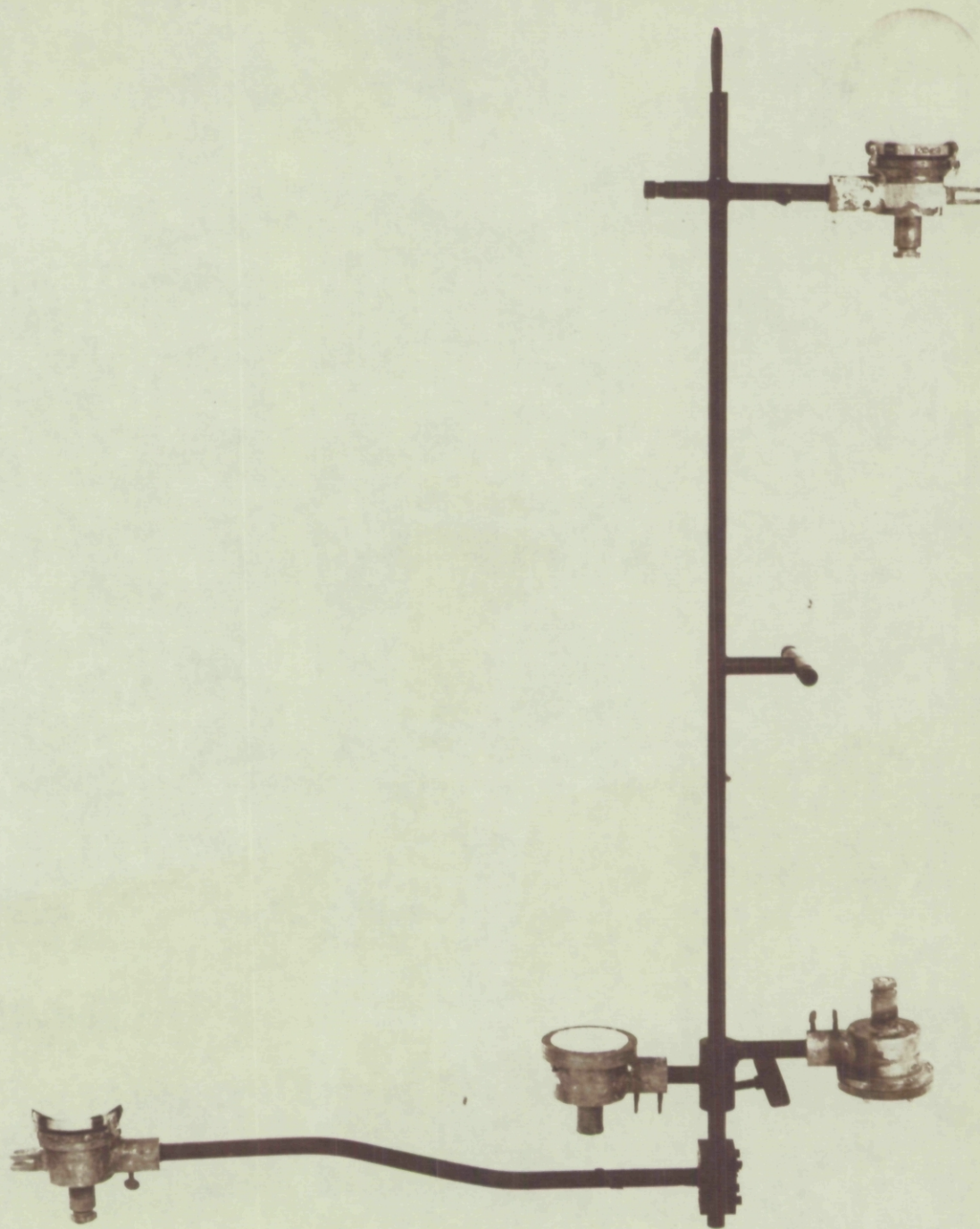

Figure 23

Instrument for determining R, K, and D.

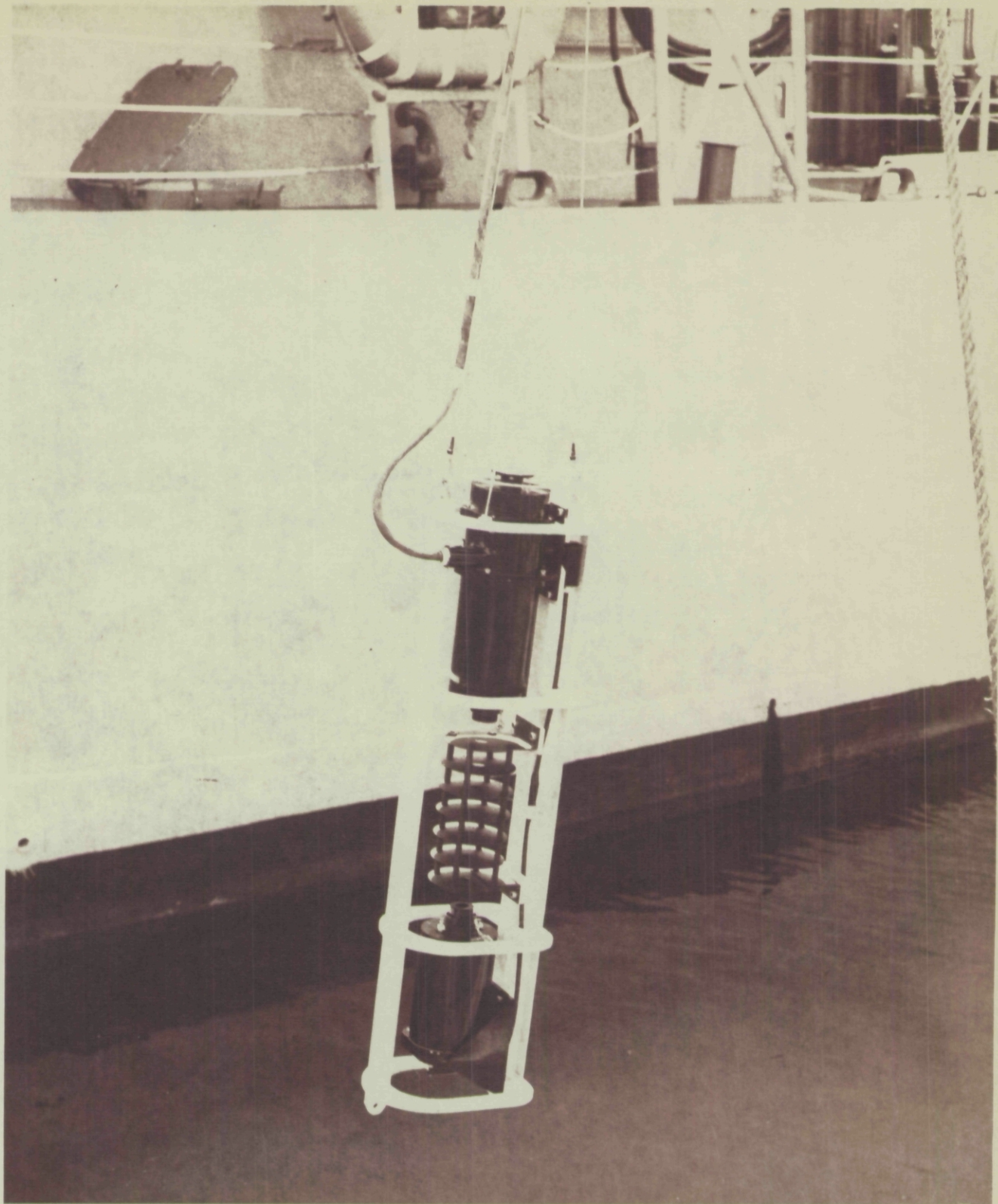

Figure 24

The coastal survey meter designed by R. W. Austin measures both λ and K.