

Lawrence Berkeley National Laboratory

Lawrence Berkeley National Laboratory

Title

A design for a combined function superconducting dipole for a muon collider FFAG accelerator

Permalink

<https://escholarship.org/uc/item/6k46q37t>

Author

Green, M.A.

Publication Date

1999-09-10

LBL-44190
SC-MAG-689

A Design for a Combined Function Superconducting Dipole for a Muon Collider FFAG Accelerator

M. A. Green

Lawrence Berkeley National Laboratory, Berkeley CA 94720, USA

September 1999

**Fourth European Conference on Applied Superconductivity
Sitges, Spain, 14 through 17 September 1999**

To be Published in the EUCAS-99 Proceedings

*This work was performed at the Lawrence Berkeley National Laboratory with the support of the Director, Office of Science, U. S. Department of Energy under Contract No. DE-AC03-76SF00098.

A Design for a Combined Function Superconducting Dipole for a Muon Collider FFAG Accelerator

Michael A. Green

Lawrence Berkeley National Laboratory, Berkeley CA 94720

ABSTRACT The acceleration stages for a muon collider require that the muons be accelerated within a given ring in fewer than twenty turns. One type of accelerator that appears to be attractive for a synchrotron that accelerates the muon a factor of four in energy in a few turns is the Fixed Field Alternating Gradient (FFAG) type of accelerator. As the energy of the muon beam increases, the muons move toward a higher field region of a DC combined function dipole. The following dipole and quadrupole magnet characteristics are required for a muon FFAG machine to be successful: 1) The dipole will be a fixed field dipole with an impressed quadrupole and sextupole field. There may or may not be separate quadrupoles that may or may not have added sextupole windings. 2) The horizontal aperture of the required good field region is wider than the vertical aperture of the required good field region. 3) The magnet is relatively short, so that the conventional SSC type of superconducting dipole or quadrupole ends can not be used. The field at the end of the magnet must fall off abruptly within the distance of less than one vertical aperture. For a magnet that is 400 mm long, the end region can be no more than 80 mm long. 4) The structure of the integrated field within the end region must be the same as the structure of the two-dimensional field at the center of the magnet. A very preliminary design concept for a FFAG combined function dipole is presented in this paper.

1. BACKGROUND

Acceleration of the muons in a muon collider requires that the muon be accelerated rapidly before they decay into two neutrinos and an electron or positron (depending on the charge of the decaying muon) Berg et al (1999). A muon at rest (the muon rest mass energy $E_r = 106$ MeV) has a life time of 2.16 microseconds. As the energy of the muon increases, above its rest mass energy, its life time becomes longer. (The life time for any particle at energy $E = \gamma$ times the life time of the particle at rest. (At energies much higher than the rest mass energy E_r , γ is approximately E divided by E_r) The most rapid way of accelerating muons is to use a linear accelerator. This type of accelerator is expensive so it is attractive to use some form of synchrotron to eliminate many kilometers of linear accelerator section.

One can eliminate an order of magnitude or more of linear accelerator structure by recirculating the beam through the same linear accelerator structure multiple times. One form of recirculating accelerator structure is the Fixed Field Alternating Gradient FFAG synchrotron. This kind of machine has been proposed for the second and third accelerator stages for a muon collider. Preliminary studies have been made of machines that accelerate muons from 4 GeV ($\gamma = 37.7$) to 16 GeV ($\gamma = 150.8$) and from 16 GeV to 64 GeV ($\gamma = 603.7$). The first stage of acceleration of the muons from their energy in the cooling channel (about 160 MeV) to 4 GeV can be done using a linear accelerator structure. The FFAG type machine appears to be attractive for the lower energy acceleration rings (below 50 to 100 GeV) for the muon collider. Above 50 to 100 GeV a recirculating linac or a pulsed (conventional) machine would be used.

The principle behind an FFAG machine is that the orbit of the machine moves slightly outward in the magnet aperture as the energy increases as described by Johnstone et al. As the orbit moves outward, the ring bending field increases. The average bending field in the FFAG rings is rather low (in our case less than 2 T), but the field at the center of the highest energy orbit might be as high as 5 or 6 T within the dipole. Two types of FFAG machines have been proposed for a muon collider. The first uses short (less than 1 meter long) constant field dipoles

alternated with large horizontal aperture quadrupoles that are about the same length as the dipoles. The second type of machine combines the dipole and the quadrupole fields in the same short dipole. With either type of FFAG accelerator, the low energy beam orbit sees a lower average bending field than do the higher energy beam orbits. An FFAG machine is a DC machine, which is desirable for magnet structure that uses superconducting magnets.

2. A SHORT MODIFIED PICTURE FRAME SUPERCONDUCTING DIPOLE

The type of dipole required for one type of FFAG machine is similar to a dipole that has been proposed for a compact synchrotron light source that uses very short high field dipoles to generate the synchrotron light as proposed by Green and Garren (1997). The warm aperture required for an FFAG is about 140 mm in the horizontal direction and about 50 mm in the vertical direction. The warm bore is cooled to remove about 4 watts of heating from the electrons and positrons produced by the decay of the muons. This is not very different from a light source dipole that has a smaller vertical aperture (20 to 40 mm depending on the machine lattice) and roughly the same horizontal aperture. In the case of the light source the bore must be cooled to remove the heat from synchrotron light. The length of the FFAG magnet is about 400 mm, which is similar to the length requirement for a compact light source dipole (See Green et al (1996). A schematic three dimensional representation of a short 6.5 to 6.9 T modified picture frame dipole is shown in Figure 1 below.

The dipole shown in Figure 1 is based on a dipole design described by Kulipanov, et al. The magnet behaves like a picture frame dipole until the induction in the good field region is above 2 T (the saturation induction for the iron). As soon as the iron in the pole saturates, the shield coils are powered to keep the magnetic flux contained in the pole until it can be returned by the iron on the outside of the shield coil. The crossover coils shape the field at the ends of the magnet. When the current in the crossover coils is the same as the current in the gap coils, the field drops off very rapidly at the magnet ends. The field drops from the full design induction of the magnet to zero in about 0.6 to 0.7 gaps. The magnetic length of the dipole is very close to the physical length of the iron. (See Green and Taylor (1998)) Unpublished studies of the crossover coils show that the field still drops off rapidly even when the current in these coils is zero, and for many application the crossover coils are probably not needed. These coils can be included in an FFAG magnet. The current in them can be optimized to produce the desired field drop off at the ends. The magnet shown in Figure 1 does not use superconductor as efficiently as some designs, but this type of magnet will produce very uniform field over a horizontal region that is up to four times as wide as the magnet gap. Thus the magnet shown below can be very attractive for applications where the magnets are short and the horizontal aperture is larger than the vertical aperture.

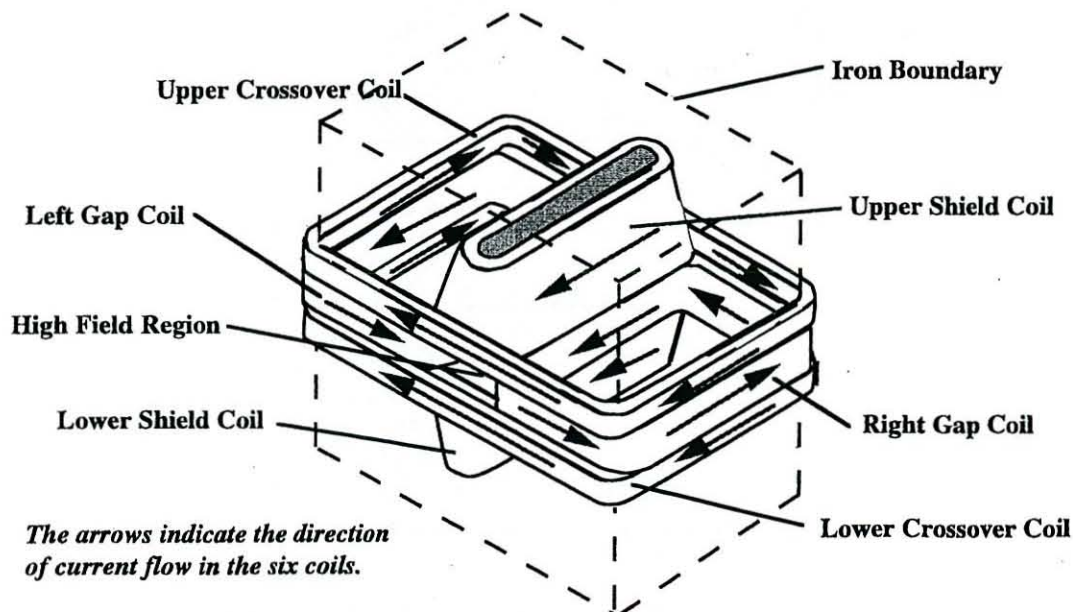

Figure 1 A Three Dimensional Representation of a 6.5 T Modified Picture Frame Dipole with a Good Field Aperture of 60 by 140 mm and a Length of 380 mm

3. A COMBINED FUNCTION SHORT FFAG DIPOLE

Figure 2 below shows the field profile needed in an FFAG dipole that will allow a twenty turn FFAG accelerator to accelerate muons from 16 GeV to 64 GeV. The region where the beam is about 112 mm wide. The cold horizontal aperture for the dipole is 140 mm. The dipole cold vertical aperture is 70 mm with about 40 mm is occupied by the muon beam during acceleration. The field profile given in Figure 2 can be fit using field polynomial expansion with a dipole of 1.217 T, a quadrupole with a gradient of 45.7 T m^{-1} , and a sextupole with a gradient of 461.2 T m^{-2} . The magnetic length of the dipole required for an FFAG machine is only 362 mm. The required integrated multipole components are as follows: $N=1$ is 0.441 Tm ; $N=2$ is 16.5 T ; and $N=3$ is 167.0 T m^{-1} . An idealized cross-section for an FFAG dipole that generates the required field profile is shown in Figure 3.

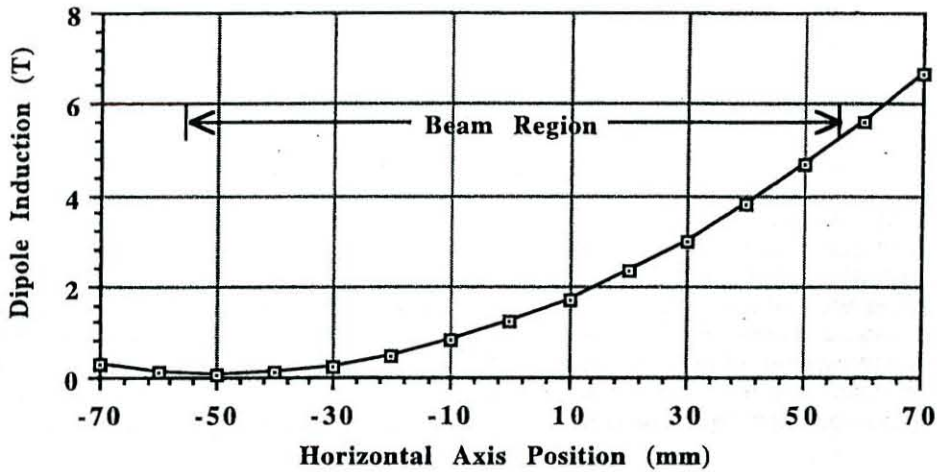

Figure 2 Field Profile across the Aperture of an FFAG Dipole at $Y = 0$

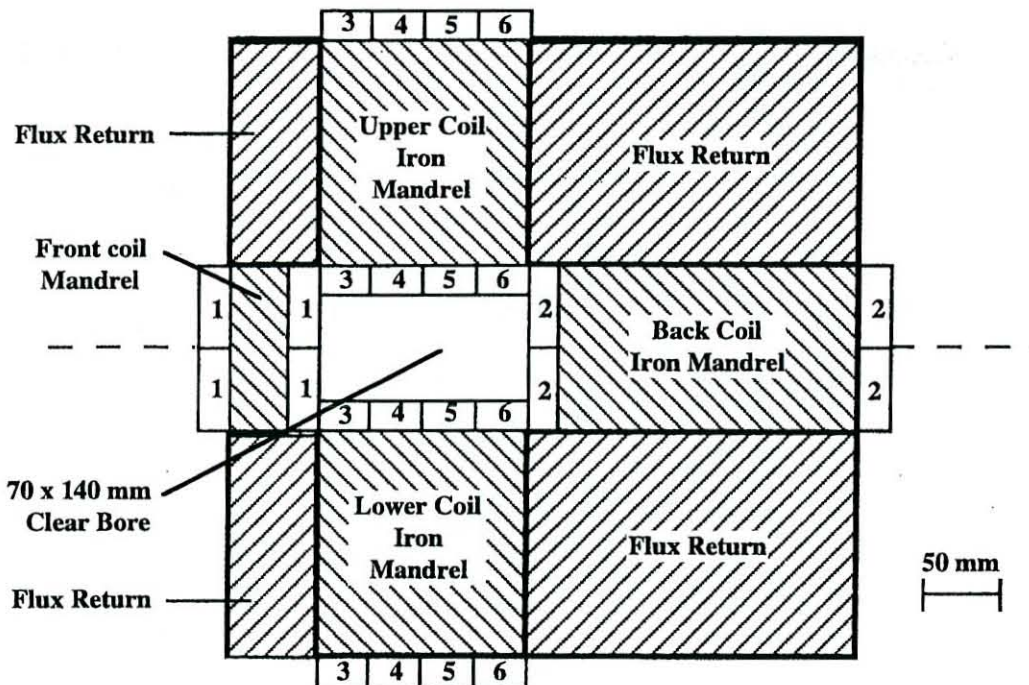

Figure 3 A Cross-section of a Variable Current Density Combined Function Dipole that Can produce the Field Profile Shown in Figure 2

The magnet shown in Figure 3 has up down symmetry, which means that it is designed not to produce any skew terms. In the configuration shown in Figure 3, each of the coils (numbered 1 through 6) has a different current density. With six current densities as variables, first six normal multipole coefficients ($N=1$ through $N=6$) can be set, to arbitrary values. The skew coefficients $N=1$ through $N=6$ are zero by symmetry. The same six coils can be used to set the induction along the magnet center line ($Y=0$ at $Z=0$) to an arbitrary value at six points along this axis. Iron saturation changes the current density in the six coils but for the most part the polarity of the current in these coils does not change as the iron saturates.

If one wants a pure dipole, coil 1 is powered to one polarity while coil 2 is at the same current density but at the opposite polarity. Coils 3 through 6 will carry current only to eliminate higher normal multipole terms introduced by iron saturation. If one wants a combined dipole and quadrupole, coils 3, 4, 5 and 6 should be powered to the same current density while coils 1 and 2 may have a different current density but opposite polarity from each other as described by Green (1997). A normal sextupole can be added by changing the current densities of the six coils.

Coils 1 and 2 can be wound in the horizontal plane around the front and back iron mandrels. Coils 3, 4, 5, and 6 can be wound in a plane parallel to the vertical axis around the top and bottom iron mandrels. The iron shown in Figure 3 is designed to carry the magnetic flux without saturation from a combined function magnet with the field profile shown in Figure 2. When the six coils shown in Figure 3 are powered to produce the field profile shown in Figure 2 (at the center of the magnet), the peak induction in the coil is expected to be close to 8 T. The stored energy for a 0.36 meter long combined function dipole that produces the field profile shown in Figure 2 in a magnet with a clear bore aperture of 70 mm by 140 mm (as shown in Figure 3) would be from 25 to 35 kJ depending on how much of the iron is saturated.

4. CONCLUDING COMMENTS

Short superconducting combined function FFAG dipole magnets can be fabricated using flat coils that are wound in a single plane. The combined function magnet can produce an arbitrary integrated field structure that is dependent on the current density and or size and shape of the coils that produce the magnetic field. The magnet shown in Figure 3 has no crossover coils to control the field fall off at the ends of the magnet. Previous studies have shown that the crossover coils are probably not needed in a magnet that has a magnetic length that is close to the physical length of the magnet.

ACKNOWLEDGEMENTS

The author thanks Carol Johnstone of the Fermi National Laboratory for her comments concerning FFAG requirement for the muon collider. This work was performed with the support of the Office of Science, United States Department of Energy under contract number DE-AC03-76SF0098.

REFERENCES

- J. S. Berg et al, "Acceleration Stages for a Muon Collider," Particle Accelerator Conference Proceedings, p 3152, IEEE Publications, Piscataway NJ (1999)
- A. A. Garren and M. A. Green, "An Alternative Lattice Design for a Compact Light Source Ring," Particle Accelerator Conference Proceedings, p 868, IEEE-97CH36167, (1997)
- M. A. Green et al, "IEEE Trans. Mag. **MAG-32**, No. 4, p 2081, (1996)
- M. A. Green, IEEE Trans. on Appl. Supercon. **7**, No. 2, p 622, (1997),
- M. A. Green and C. E. Taylor, IEEE Trans. Appl. Supercon. **9**, No. 2, p 370, (1999)
- C. Johnstone, W. Wan and A. A. Garren, "Fixed Field Accelerator Designs," Particle Accelerator Conference Proceedings, p 3068, IEEE Publications, Piscataway NJ (1999)
- G. N. Kulipanov, et al, Rev. Sci. Instrum. **63** (1), p 731 (1992)