

Lawrence Berkeley National Laboratory

LBL Publications

Title

PHOTOFISSION CROSS SECTIONS OF U235, U238, Th232, Bi209 AT ENERGIES OF 150 TO 500 Mev

Permalink

<https://escholarship.org/uc/item/6ks3k7q9>

Authors

Jungerman, John A.
Steiner, Herbert M.

Publication Date

1956-11-30

UNIVERSITY OF
CALIFORNIA

*Radiation
Laboratory*

TWO-WEEK LOAN COPY

*This is a Library Circulating Copy
which may be borrowed for two weeks.
For a personal retention copy, call
Tech. Info. Division, Ext. 5545*

BERKELEY, CALIFORNIA

DISCLAIMER

This document was prepared as an account of work sponsored by the United States Government. While this document is believed to contain correct information, neither the United States Government nor any agency thereof, nor the Regents of the University of California, nor any of their employees, makes any warranty, express or implied, or assumes any legal responsibility for the accuracy, completeness, or usefulness of any information, apparatus, product, or process disclosed, or represents that its use would not infringe privately owned rights. Reference herein to any specific commercial product, process, or service by its trade name, trademark, manufacturer, or otherwise, does not necessarily constitute or imply its endorsement, recommendation, or favoring by the United States Government or any agency thereof, or the Regents of the University of California. The views and opinions of authors expressed herein do not necessarily state or reflect those of the United States Government or any agency thereof or the Regents of the University of California.

UNIVERSITY OF CALIFORNIA

Radiation Laboratory
Berkeley, California

and

Department of Physics
Davis, California

Contract No. W-7405-eng-48

PHOTOFISSION CROSS SECTIONS OF U^{235} , U^{238} , Th^{232} ,
 Bi^{209} , AND Au^{197} AT ENERGIES OF 150 TO 500 Mev

John A. Jungerman and Herbert M. Steiner

November 30, 1956

PHOTOFISSION CROSS SECTIONS OF U^{235} , U^{238} , Th^{232} ,
 Bi^{209} , AND Au^{197} AT ENERGIES OF 150 TO 500 Mev

John A. Jungerman

Department of Physics
University of California
Davis, California

and

Radiation Laboratory
Berkeley, California

and

Herbert M. Steiner

Radiation Laboratory
University of California
Berkeley, California

November 30, 1956

ABSTRACT

Photofission cross sections for U^{238} , U^{235} , Th^{232} , Bi^{209} , and Au^{197} have been measured by use of bremsstrahlung spectra whose maximum energies ranged from 150 to 500 Mev. The fissions were detected in 2π geometry with a double ionization chamber. A suggested correlation of the resulting cross sections with those for proton fission and for photomeson production is made.

PHOTOFISSION CROSS SECTIONS OF U^{235} , U^{238} , Th^{232}
 Bi^{209} , AND Au^{197} AT ENERGIES OF 150 TO 500 Mev*

John A. Jungerman
Department of Physics
University of California
Davis, California

and

Radiation Laboratory
Berkeley, California

and

Herbert M. Steiner
Radiation Laboratory
University of California
Berkeley, California

November 30, 1956

I. INTRODUCTION

Several experiments have been performed to investigate photofission cross sections in the energy region 100 to 300 Mev.¹⁻⁵ In the experiment here presented we have investigated the photofission cross sections of U^{238} , U^{235} , Th^{232} , Bi^{209} , and Au^{197} for photons produced in bremsstrahlung spectra whose maximum energies ranged from 150 to 500 Mev. The energy region 150 to 335 Mev was investigated for the most part at the University of California synchrotron, whereas the higher-energy data were obtained at the synchrotron of the California Institute of Technology. In a previous paper⁶ (hereafter referred to as A) we have reported the high-energy proton-induced fission cross sections of the above elements. The same apparatus and essentially the same methods were used in the measurement of the photofission cross sections.

* This work was done under the auspices of the U. S. Atomic Energy Commission.

II. APPARATUS AND METHOD

A. Fission Chamber

The ionization chamber used in this experiment is described in A. The beam was passed through the chamber in the direction CBA in order to minimize the effect of the electron-positron pairs produced in the sample backing. The distance from the thin entrance window to the sensitive region of the ionization chamber was approximately 4 inches, so that any pairs produced in the entrance window had only a small chance of producing uncanceled pulses in the sensitive region of the ionization chamber. In order to minimize pair production in the gas, the chamber was filled with 1 atmosphere of hydrogen. Finally, pair production in the electrodes was kept small by making them of $140\text{-}\mu\text{g}/\text{cm}^2$ aluminum foil.

Chronologically, most of the photofission experiments were performed prior to the proton experiments described in A. Throughout most of the photofission runs only one scaler was used to record the number of pulses from the ionization chamber. However, in the last photofission run at the Berkeley synchrotron we switched to a system of using six scalers simultaneously in order to obtain an integral bias curve for each element at each energy. Otherwise the electronic arrangement was identical to that described in A.

B. Samples

The samples used in the photofission runs were identical to those used for the proton experiments, ⁶ with the exception of Th^{232} and Au^{197} , which had thicknesses of $0.88\text{ mg}/\text{cm}^2$ and $1.07\text{ mg}/\text{cm}^2$, respectively. The Th^{232} was prepared by painting as described in A, whereas a thin foil was used for the gold sample. In order to correct for sample thickness effects, thin samples (0.1 to $0.4\text{ mg}/\text{cm}^2$) of U^{238} , U^{235} , Th^{232} , and Bi were exposed to the proton beam of the Berkeley cyclotron. By comparing the yields of fission fragments from the thin samples with those from thicker samples, we obtained sample-thickness correction factors. These corrections have been applied to the samples used in these photofission experiments, and are of the order of 10%.

C. Method

Figure 1 shows a diagram of the experimental arrangement at Berkeley. The bremsstrahlung beam was generated in a 0.020-inch platinum target, collimated to 3/4-inch diameter, passed through a sweep magnet, then through the fission chamber, and finally into a thick-walled ionization chamber, which was a duplicate of a chamber calibrated by Dr. R. Wilson at Cornell. At the calibration point the maximum energy of the bremsstrahlung spectrum of the Cornell synchrotron was 315 Mev. At this point, every coulomb of charge collected by the beam-monitoring ionization chamber corresponded to an integrated photon energy of 3.73×10^{18} Mev.⁷ The group at California Institute of Technology has calibrated a similar "Cornell" chamber at 500 Mev. They find a value of 4.13×10^{18} Mev/coulomb.⁸ A linear energy dependence of 5.3% per 100 Mev was therefore assumed, and this correction has been applied in order to obtain the number of equivalent quanta at various energies. If the energy dependence should be found to differ from 5.3% per 100 Mev, then the fission cross sections reported here must be corrected accordingly.

In order to determine the maximum energy of the synchrotron beam, a pair spectrometer designed by Dr. Robert W. Kenney was used at Berkeley with the "Cornell" chamber removed. The electron-pair trajectories in vacuum, coupled with a nuclear resonance determination of the pair-spectrometer magnetic field, determine the energy of the bremsstrahlung beam on an absolute scale. The operation of this spectrometer is described in more detail by McDonald.⁹ The maximum energy of the beam was determined in this way for each energy studied.

The synchrotron at Berkeley has a repetition rate of 6 cycles/sec and the beam comes out in a 2500- μ sec time interval when operating at full energy (337 Mev). However, when the beam energy was reduced appreciably below its maximum value the beam spilled out in a time on the order of 10 μ sec. This "spiked" beam made it necessary to run at rather low beam intensities because of the chance of losing fission counts by having several arrive during the resolving time of our apparatus (5 μ sec). This circumstance also made the energy determination more difficult because low beam intensities were necessary to reduce accidental counts in the pair spectrometer to a reasonable level. In the last run at Berkeley it became possible to extend the duration of the beam to 1 msec at reduced energies.

The experiment at the California Institute of Technology was performed with the same fission chamber and electronic apparatus as at Berkeley. The path from the 0.016-inch copper bremsstrahlung target to the fission chamber was

somewhat longer, so that the solid angle subtended by the fission chamber was less than in the experimental arrangement at Berkeley. The Cal Tech synchrotron beam had a pulse duration of 1 msec at all energies, and a repetition rate of 1 pulse per second. The increased duty cycle at reduced energies greatly facilitated the gathering of reliable data. The maximum beam energy was determined to $\pm 1\%$ by use of the calibrated rf pulse-timing equipment of the Cal Tech synchrotron.⁸

III. PROCEDURE

Before each photofission run a Po-Be source encased in paraffin was placed adjacent to the fission chamber with the U^{235} sample in place. By observing the resulting fission pulses we were able to check the over-all operation of the apparatus. By observing an integral bias curve, we were able to determine that the electron-collection efficiency of the chamber remained constant during the entire course of the experiment.

The alignment of the fission chamber, with respect to the beam, was checked by taking shadowgraphs of the beam passing through the chamber with photographic film. Pictures were taken every time the chamber was moved or the operation of the synchrotron changed markedly.

At the start of each photofission run the aluminum blank target was placed in the beam. The voltage on the cancellation electrode C was then adjusted until a minimum signal was observed in an oscilloscope. We found that this remanent background signal was strongly dependent on the intensity and the duration of the beam pulse. With the highest-intensity "spiked" beam used, the background caused by noncancellation of beam ionization, as determined with the aluminum blank target, was less than 2% of the fission rate for U^{235} , U^{238} , and Th^{232} . For bismuth, the background was less than 10%, and for gold it was less than 23% at all energies. This background was quite constant for a given beam intensity at a given energy, and thus could be subtracted with good reliability.

In order to avoid losing more than 1% of the fissions due to pile-up of fission pulses, a counting rate of less than 36 counts/min had to be used with the "spiked" beam. This counting rate was determined experimentally by measuring the counting rate per microcoulomb collected in the "Cornell" chamber versus the reciprocal of the beam intensity. This curve is shown in Fig. 2.

A similar curve was also made of counting rate per microcoulomb versus the pulse height necessary to trip out scaler. This curve was used to extrapolate the observed counts to zero bias, and is similar to the bias curve shown in Figure 4 of Reference A. In the last run at Berkeley, six scalers were used at 2.5-volt bias intervals, giving a five-channel integral pulse spectrum. In this manner a bias plateau was obtained for each sample at each energy. We believe the data collected in this manner to be more reliable because of the increase in information available.

The counting rate per microcoulomb collected was also measured versus the voltage on the collecting and cancellation electrodes, and a suitable plateau was obtained. The final operating voltages were $B = 1500$ v, $C = 3300$ v for most of the runs.

In all runs at Berkeley an electronic gate was used that allowed our scalers to count only while the beam was on. Electrical disturbances from the synchrotron operation were quite prominent if the gate was not used.

The fissioning effect of photoneutrons was estimated by using the U^{235} sample, which should be the most neutron-sensitive. There are two main sources of neutrons, (a) neutron contamination of the beam (probably due mostly to photoneutrons produced in the walls of the doughnut and the collimator), (b) photoneutrons produced in the aluminum sample backing. The effect of the neutrons in the beam was checked by shifting the fission chamber 6 inches to one side so that it just cleared the beam. The resulting counting rate was less than 2% of the rate with the same intensity photon beam passing through the chamber. The effect of the photoneutrons produced in the sample backing was investigated by increasing the effective thickness of the aluminum backing from 0.001 inch to 0.026 inch; no increase was observed in the photofission yield of U^{235} .

A check was made of the effect of electron contamination of the beam on the observed fission yields by inserting a sweep magnet immediately in front of the fission chamber. No effect was observed.

IV. EXPERIMENTAL RESULTS

The fission cross section per equivalent quantum, σ_Q , for both the Berkeley and Cal Tech experiments, is presented in Table I and plotted in Figs. 3 and 4. The energy scale is logarithmic, since in this presentation the slope of the curve represents the fission cross section if a rectangular bremsstrahlung spectrum is assumed. It will be noted that the change in accelerators shifts the cross section per equivalent quantum by about 15% for U^{235} , U^{238} , and Th^{232} at the joining energy of 335 Mev. For bismuth, shown in Fig. 4, the change of accelerators is perhaps masked by the steepness of the σ_Q curve. Since the cross section per equivalent quantum depends not only on the calibrated ionization chamber and its associated electronic equipment, but also on the value ascribed to the maximum beam energy, errors in any of these variables on either accelerator could lead to the discrepancy in the absolute value for σ_Q at 335 Mev. In all cases, however, the slopes of the σ_Q curves seem to be continuous.

If we use the rectangular spectrum approximation, the curves of σ_Q versus the maximum energy of the bremsstrahlung spectra for U^{238} , U^{235} , and Th^{232} can most easily be fitted with a straight line having a slope corresponding to a constant photofission cross section versus photon energy of about 25 to $50 \times 10^{-27} \text{ cm}^2$ in the energy region 200 to 500 Mev. A more careful analysis is probably not justified because of the limited accuracy of the experimental results.

An analysis to obtain the bismuth fission cross section, using the bremsstrahlung spectra ¹⁰ from Schiffer and taking into account the dependence of the spectrum shape on the maximum energy of the bremsstrahlung, was made by the method described by Katz and Cameron. ¹¹ We found, for a given smoothed plot of the σ_Q curve, that the cross section increased about 15% but had about the same shape as given by the rectangular bremsstrahlung spectrum. It was noted also that the arbitrariness allowed in drawing a smooth curve through the experimental points creates the same order of uncertainty as the difference between the two methods of spectrum analysis. We have therefore used the rectangular spectrum because of its simplicity. The fission cross sections resulting from these analyses are shown in Fig. 5. They are derived from the smoothed curves shown in Fig. 4.

Table I

Fission cross section per equivalent quantum for 100- to 500-Mev photons
(In units of 10^{-27} cm²)

Maximum energy E of bremsstrahlung spectrum in Mev	U ²³⁸	U ²³⁵	Th ²³²	Bi ²⁰⁹	Au ¹⁹⁷
500*	—	247 ± 10	65.8 ± 2.0	6.82 ± 0.14	1.57 ± 0.09
480*	159 ± 5	—	64.7 ± 1.5	6.17 ± 0.20	—
476*	—	257 ± 15	63.9 ± 1.5	6.16 ± 0.20	—
471*	—	—	63.4 ± 1.3	—	—
466*	—	—	—	6.25 ± 0.20	—
451*	—	—	—	6.10 ± 0.18	1.42 ± 0.14
431*	152 ± 3	252 ± 7	57.8 ± 1.2	5.48 ± 0.17	—
408*	—	—	—	5.09 ± 0.17	—
400*	—	—	—	—	1.23 ± 0.11
389*	—	—	60.5 ± 2.0	—	—
385*	151 ± 2	—	51.0 ± 1.1	4.71 ± 0.14	—
362*	—	—	—	4.00 ± 0.09	—
350*	—	—	—	—	0.86 ± 0.10
335*	181 ± 1	274 ± 1	58.5 ± 0.5	3.06 ± 0.06	—
335*	146 ± 2*	235 ± 6*	50.5 ± 1.1*	3.12 ± 0.13*	—
300	163 ± 2	244 ± 6	53.0 ± 1.1	—	0.72 ± 0.08
291	168 ± 5	276 ± 5	61.2 ± 1.8	—	—
285*	173 ± 5	—	55.7 ± 1.3	1.85 ± 0.13	0.78 ± 0.06
285*	—	—	—	2.26 ± 0.18*	—
250*	151 ± 3	239 ± 6	50.2 ± 1.4	—	—
250*	—	—	—	1.78 ± 0.22*	0.33 ± 0.07*
244	170 ± 5	270 ± 7	51.3 ± 1.3	—	—
232	—	239 ± 4	—	—	—
208*	154 ± 4	244 ± 8	42.8 ± 1.2	1.18 ± 0.28	—
200*	—	—	—	1.30 ± 0.24*	0.31 ± 0.09*
180*	154 ± 3	238 ± 5	44.2 ± 0.8	0.68 ± 0.09	—
150*	—	—	—	0.61 ± 0.12*	—
143	147 ± 4	226 ± 6	43.3 ± 1.4	—	—

* Data obtained at California Institute of Technology.

It should be noted that the use of a longer beam duration in the last run at Berkeley yielded the same cross sections for U^{235} , U^{238} , and Th^{232} as obtained in the earlier runs. It also allowed a more reliable measurement of the bismuth cross section at reduced energies. On previous runs with bismuth at reduced energies the uncanceled beam-ionization background made measurements untrustworthy. However, even in the last run there was still a residual background, which was apparently electrical in nature, that made the measurements with the gold target at Berkeley unreliable. It should be mentioned also that the 200-Mev point obtained for gold at Cal Tech is based on 11 counts and the 300-Mev point on 83 counts, so that the cross sections reported are quite provisional. This scarcity of counts arises from the fact that both the fission cross section and the beam strength decrease markedly as the energy is decreased, so that the time necessary to increase the number of counts becomes prohibitive. In addition to the statistical errors indicated on the graphs the σ_D curves can have systematic errors due to errors in sample thickness, $\pm 7\%$; errors in calibration for the number of equivalent quanta including ϵ energy dependence, $\pm 8\%$; error in extrapolation to zero bias, $\pm 5\%$; errors in determination of the beam energy, $\pm 2\%$. A total probable systematic error of $\pm 13\%$ can thus be ascribed to the cross sections presented in the curves shown in Figs. 3 and 4.

V. DISCUSSION

A. Bismuth and Gold

From the data in Fig. 4 we note that the photofission cross sections per equivalent quantum for bismuth and gold both increase rapidly as the maximum energy of the bremsstrahlung spectra is increased, especially in the energy region above 300 Mev. Upon analyzing the σ_Q curves we find that the photofission cross section of bismuth, $\sigma(k)$, increases with increasing photon energy k until it reaches a maximum value of about $10 \times 10^{-27} \text{ cm}^2$ at about 400 Mev. With the present fit of the σ_Q data, the $\sigma(k)$ curve indicates a resonance type of behavior near 400 Mev; i. e., the cross section seems to decrease again above this energy. The cross section for gold shows a similar behavior, reaching a maximum value of about $2 \times 10^{-27} \text{ cm}^2$ at 400 Mev. It must be emphasized, however, that the arbitrariness involved in drawing a smooth curve through the experimental points for both Bi and Au is such that $\sigma(k)$ may not be decreasing above 400 Mev. In order to definitely determine whether or not this resonance type of behavior of the photofission cross section is real, experiments should be carried out at higher energies (500 to 1000 Mev).

Because of the similarity of the curves of $\sigma(k)$ versus k for photofission and for the photoproduction of mesons from nucleons, it is tempting to relate the two processes. A possible interpretation of our results, first suggested by Bernardini, Reitz and Segré,² is that internally produced mesons are re-absorbed within the nucleus in which they are created, thus giving an additional mechanism by which a nucleus may absorb the photon energy. Let us pursue this possibility a little further. We have seen that the photofission cross sections of bismuth and gold reach their maximum value at about $k = 400$ Mev. However, the results of photomeson production experiments¹²⁻¹⁵ indicate that the peaks of the cross sections for photomeson production from nucleons occur near $k = 300$ Mev. Furthermore, the width of the photofission "resonance" (if we assume that it is real) is somewhat broader than the corresponding width in photomeson production. These differences can be explained if we recall that there are several factors influencing photofission that are not present in photomeson production from nucleons. First, in photoproduction the motion of the nucleons inside the nucleus causes a broadening of the photomeson spectrum

because of the Doppler effect. Second, the effect of the Pauli principle is such that when a photomeson is produced from a nucleon in the nucleus, the struck nucleon must go into an unoccupied nucleon state. Because the low-energy nucleon states are already filled, the production of high-energy mesons is favored. This effect therefore causes the resonance to shift toward higher energies. Possibly most important of all, the reabsorption of the meson within the nucleus in which it was created depends on the energy of the meson. Various experimenters have found¹⁶⁻²⁴ that the absorption mean free path of mesons in nuclear matter decreases with increasing meson energy. Therefore, the absorption of high-energy mesons is favored, which again would tend to shift the photofission resonance toward higher energies. Thus, the experimental data on the photofission of bismuth and gold are consistent with the interpretation of reabsorption of internally produced photomesons.

We can use the results of charged-particle-induced fission experiments to make a rough estimate of the total photonuclear cross sections of bismuth and gold. To do this we assume that the ratio of the fission cross section to the total cross section is independent of how the nucleus is excited. From the results reported in A, in conjunction with experiments on alpha-particle- and deuteron-induced fission (to be published), we find that the fission cross sections of bismuth and gold at about 300 Mev are about 0.15 and 0.04 respectively, of the total inelastic cross section for these elements. Dividing the observed photofission cross sections by 0.15 for bismuth and by 0.04 for gold we obtain total photonuclear cross sections of about $70 \times 10^{-27} \text{ cm}^2$ for bismuth, and about $60 \times 10^{-27} \text{ cm}^2$ for gold at $k \approx 400 \text{ Mev}$. It is interesting to note that if we assume that the total photonuclear cross sections of bismuth and gold at $k \approx 400 \text{ Mev}$ are due either directly or indirectly only to photomeson production, then we obtain a cross section of about $80 \times 10^{-27} \text{ cm}^2$ by simply adding the total photomeson cross sections of the individual nucleons in these nuclei.

The similarity of the σ_Q curve for bismuth to the photostar excitation function per equivalent quantum obtained by Peterson²⁵ is also interesting, and suggests that the same mechanism might account for both phenomena.

B. Uranium-238, Uranium-235, and Thorium-232

Since the photofission thresholds for U^{238} , U^{235} , and Th^{232} are all about 5 Mev,²⁶ it is reasonable to expect that a large contribution to the photofission cross sections per equivalent quantum for these elements occurs at low energies, i. e., in the "giant resonance" region.²⁷ Any meson effects of the type observed in bismuth and gold would presumably be masked by the effects of the low-energy quanta. Indeed, from Fig. 3 we see that the relative increase of σ_Q with increasing energy is much smaller for U^{238} , U^{235} , and Th^{232} than for bismuth or gold. The relative increase of σ_Q with increasing energy is most pronounced for Th^{232} and smallest for U^{235} , as would be expected, since the effect of the low-energy quanta is greatest for U^{235} and smallest for Th^{232} .

A second point of interest is that for U^{235} the photofission cross section per equivalent quantum is about 1.6 times that of U^{238} at all energies investigated in this experiment. If we assume that the photons in the "giant resonance" are primarily responsible for causing the fissions, then either the total photonuclear cross sections differ for U^{235} and U^{238} for low-energy photons, or the relative fissionability of U^{235} is greater than that of U^{238} at excitation energies of several Mev. Support for the latter conclusion comes from the data on the neutron-induced fission of several isotopes of uranium at neutron energies of 2 to 4 Mev.²⁸ The results of these experiments indicate that the fission cross sections vary by large factors (2 to 3), depending upon which isotope of uranium is used.

ACKNOWLEDGMENTS

This experiment was carried out with the help and advice of many persons. In particular, we would like to thank Professor Emilio Segrè for suggesting this problem, and for his guidance and help throughout the course of the experiment. Our thanks also go to Professor Owen Chamberlain and Dr. Clyde Wiegand for many helpful suggestions and interesting discussions. We acknowledge with pleasure the wholehearted cooperation extended to us by Professor Robert F. Bacher and the Staff of the California Institute of Technology synchrotron, and in particular, to Dr. Vincent Z. Peterson, who assisted us throughout the run there. Assistance with the pair magnet monitor at Berkeley by Dr. Robert Kenney, Dr. Charles McDonald, and Dr. John Anderson is gratefully acknowledged. Thanks are also due to Dr. William Imhoff, who supervised the construction of duplicates of the Cornell ionization chambers for calibration of the Berkeley synchrotron beam. Finally, we wish to thank the staff of the Berkeley synchrotron, under the direction of Mr. George McFarland, for their helpfulness throughout the course of the experiment.

REFERENCES

1. R. A. Schmitt and N. Sugarman, *Phys. Rev.* 89, 1155 (1953).
2. Bernardini, Reitz, and Segrè, *Phys. Rev.* 90, 573 (1953).
3. J. Gindler, "The Photofission of Heavy Elements" (Thesis),
University of Illinois (1954).
4. R. A. Schmitt and N. Sugarman, *Phys. Rev.* 95, 1250 (1954).
5. Katz, Kavanagh, Cameron, Bailey, and Spinks, *Phys. Rev.* 99, 98 (1955).
6. H. Steiner and J. Jungerman, *Phys. Rev.* 101, 807 (1956).
7. Robert Wilson, Cornell University, private communication.
8. Vincent Z. Peterson, California Institute of Technology, private communication.
9. C. A. McDonald, Pair Production in the Field of Orbital Electrons by a
Total Absorption Method at 300 Mev (Thesis), UCRL-2595, June 1954.
10. L. I. Schiff, *Phys. Rev.* 70, 87 (1946);
Phys. Rev. 83, 252 (1951).
11. L. Katz and A. G. W. Cameron, *Can. J. Phys.* 29, 518 (1951).
12. D. C. Oakley and R. L. Walker, *Phys. Rev.* 97, 1283 (1955).
13. Walker, Oakley, and Tollestrup, *Phys. Rev.* 97, 1279 (1955).
14. Walker, Teasdale, Peterson, and Vette, *Phys. Rev.* 99, 210 (1955).
15. Tollestrup, Keck, and Worlock, *Phys. Rev.* 99, 220 (1955).
16. D. H. Stork, *Phys. Rev.* 93, 868 (1954).
17. Chedester, Isaacs, Sachs, and Steinberger, *Phys. Rev.* 82, 958 (1951).
18. R. M. Littauer and D. Walker, *Phys. Rev.* 86, 838 (1952).
19. Panofsky, Steinberger, and Stellar, *Phys. Rev.* 86, 180 (1952).
20. A. Shapiro, *Phys. Rev.* 84, 1063 (1951).
21. K. Button, *Phys. Rev.* 88, 956 (1952).
22. Bernardini, Booth, and Lederman, *Phys. Rev.* 83, 1075 and 1277 (1951).
23. R. Martin, *Phys. Rev.* 87, 1052 (1952).
24. Goldschmidt-Clermont, Osborne, and Scott, *Phys. Rev.* 97, 188 (1955).
25. V. Z. Peterson, *Phys. Rev.* 96, 850 (1954).
26. Koch, McElhinney, and Gasteiger, *Phys. Rev.* 77, 329 (1950).
27. J. M. Blatt and V. F. Weisskopf, *Theoretical Nuclear Physics* (New York
Wiley, 1952) Ch. XII, p. 583.
28. D. J. Hughes and J. A. Harvey, *Neutron Cross Sections*, (2nd Edition)
BNL-325, 1955.

LEGENDS

- Fig. 1. Schematic diagram of the experimental arrangement at the Berkeley synchrotron. (The drawing is not to scale.)
- Fig. 2. Counting rate plotted against the reciprocal of the beam intensity for a "spiked" beam at the Berkeley synchrotron. The ordinate shows the number of counts observed while the beam monitor collected 1 microcoulomb of charge. The abscissa shows the time (in minutes) necessary to charge the beam monitor to 1 microcoulomb.
- Fig. 3. Photofission cross section per equivalent quantum σ_Q versus bremsstrahlung energy for U^{235} , U^{238} , and the Th^{232} . The errors indicated on the points are standard deviations due to counting statistics only.
- Fig. 4. Photofission cross section per equivalent quantum, σ_Q , versus bremsstrahlung energy for Bi^{209} and Au^{197} . The errors indicated on the points are standard deviations due to counting statistics only.
- Fig. 5. Photofission cross section, $\sigma(k)$, of Bi and Au as a function of photon energy. These curves were obtained from a smoothed plot of the data in Fig. 4. The dotted curve was calculated by assuming a Schiff bremsstrahlung spectrum that varied with energy, using the method of Katz and Cameron.¹¹ The solid curves were calculated in the rectangular spectrum approximation.

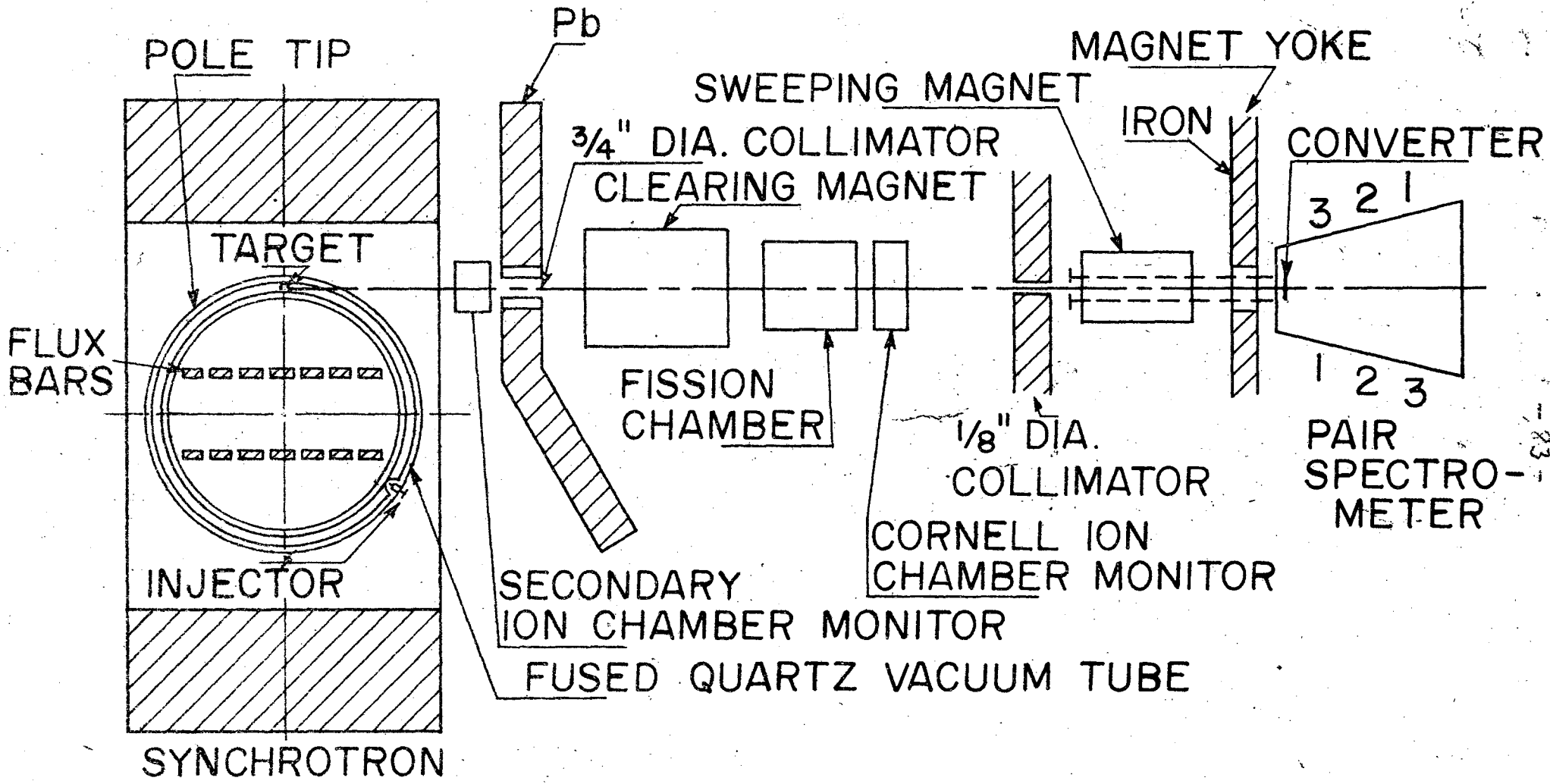

Fig 1

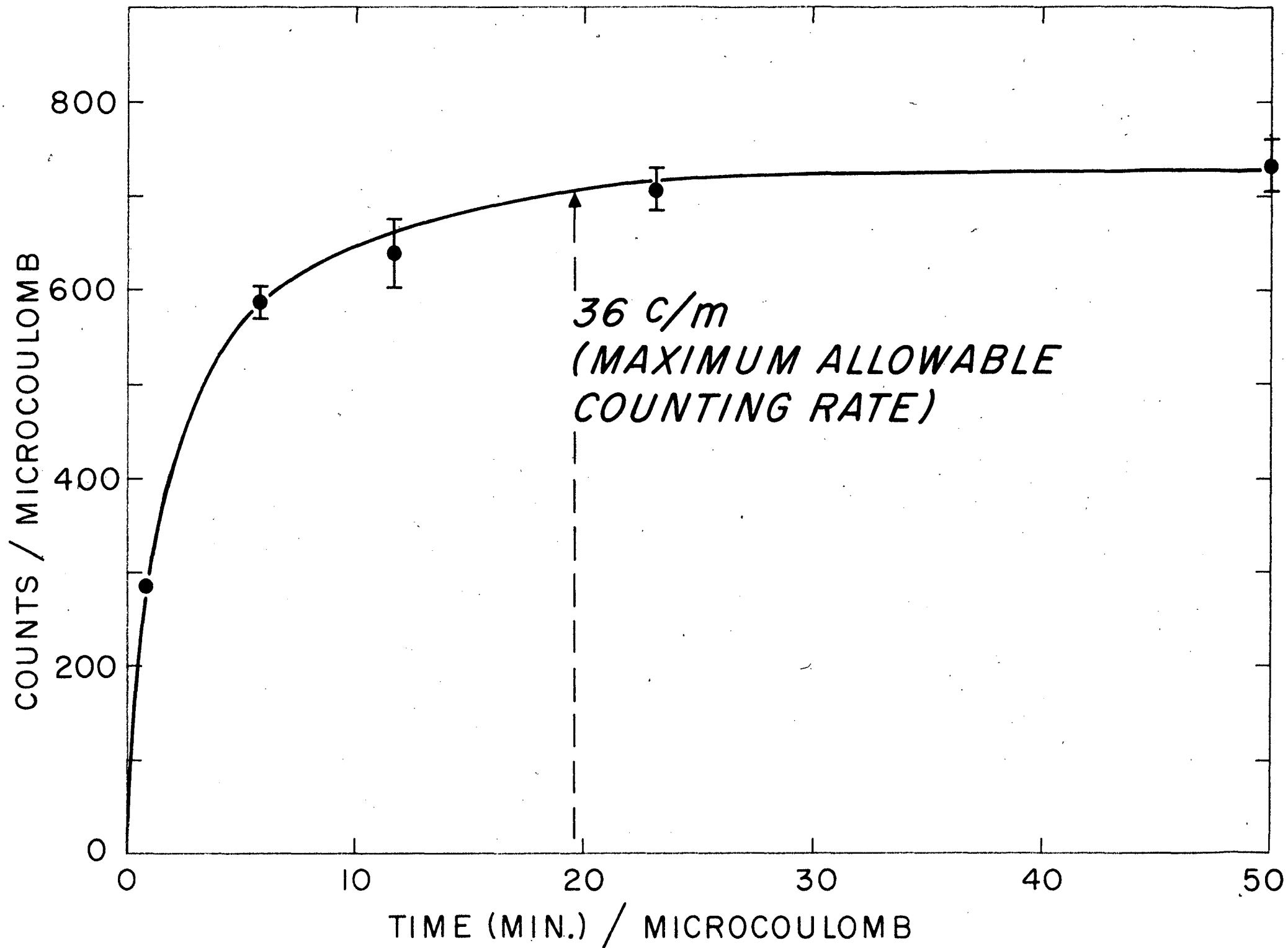

fig 2

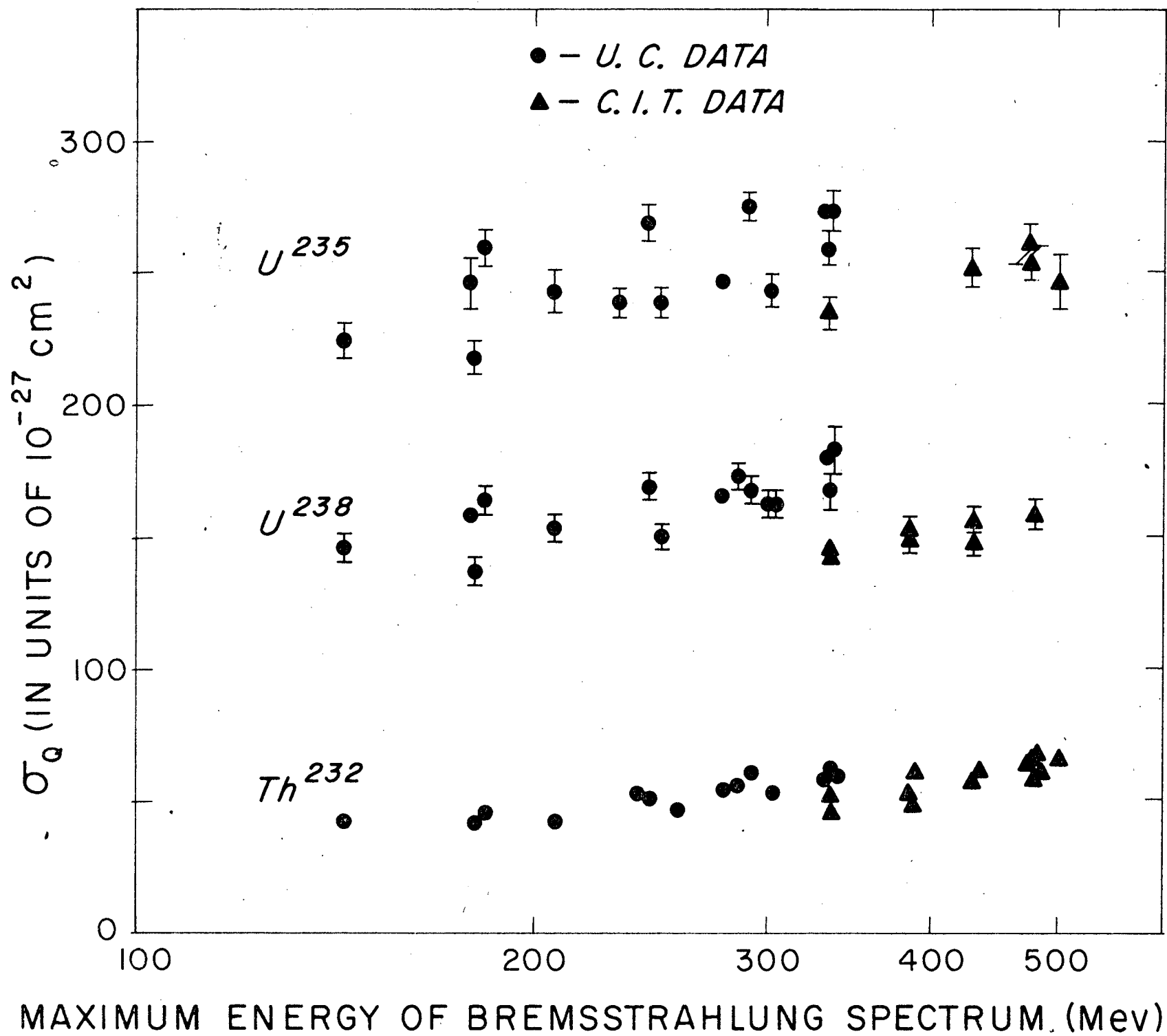

Fig 3

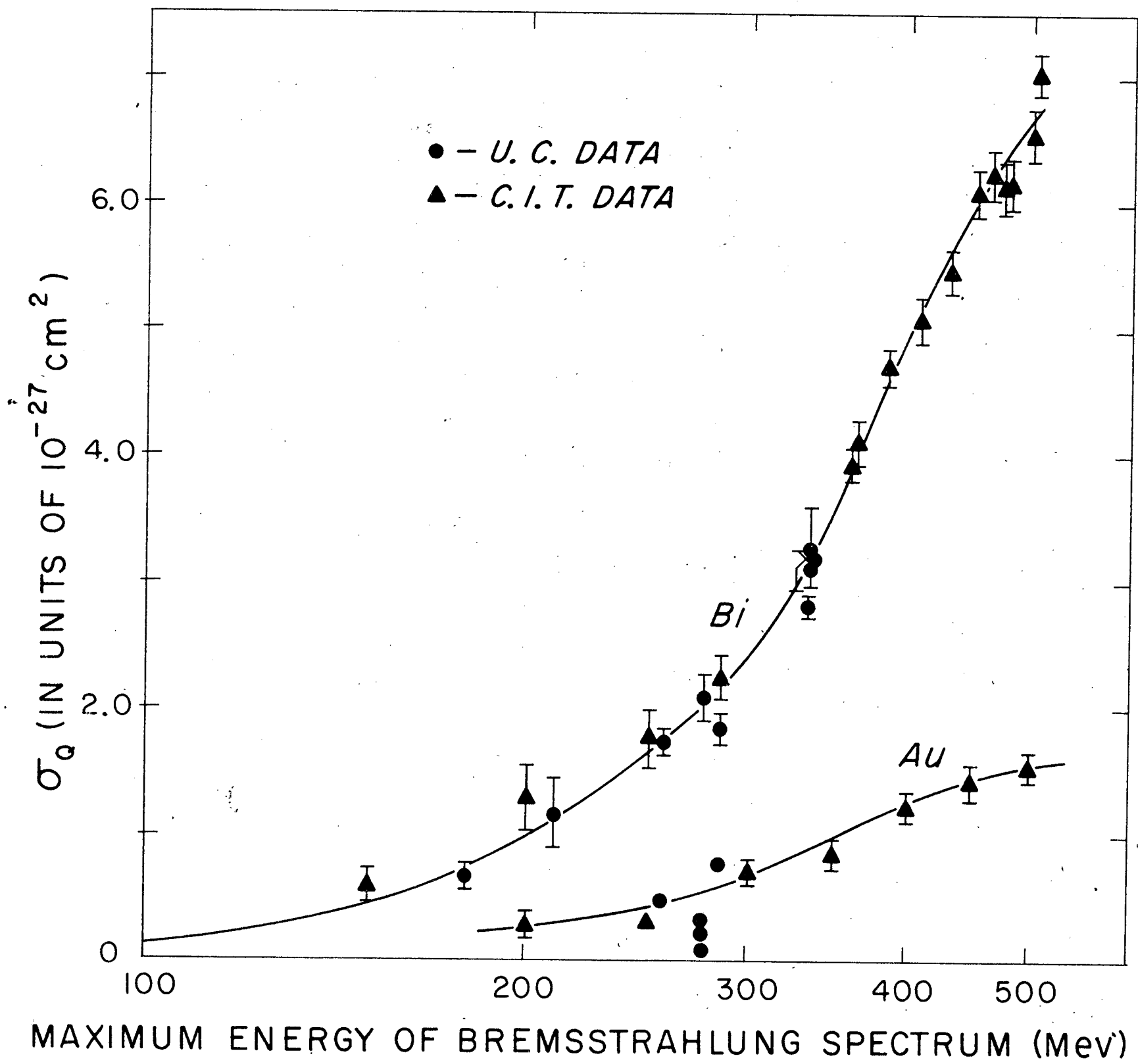

Fig 4

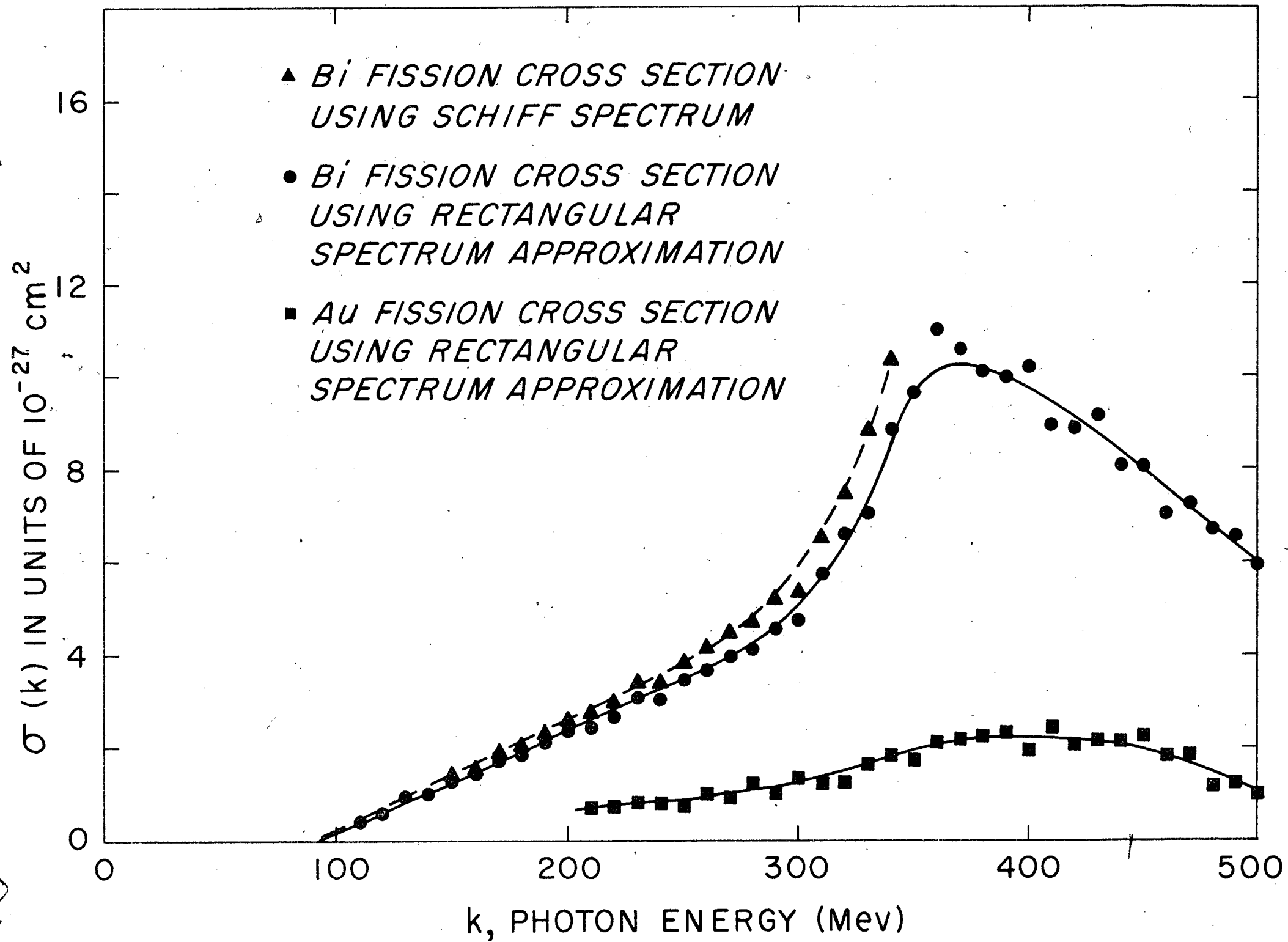

fig 5