

Lawrence Berkeley National Laboratory

LBL Publications

Title

Direct Determination of the Phase Distributions of Semi-Volatile Polycyclic Aromatic Hydrocarbons Using Annular Denuders

Permalink

<https://escholarship.org/uc/item/6n91z5d7>

Authors

Gundel, L A

Lee, V C

Mahanama, K R R

et al.

Publication Date

1994-06-01



Lawrence Berkeley Laboratory

UNIVERSITY OF CALIFORNIA

ENERGY & ENVIRONMENT DIVISION

Submitted to Atmospheric Environment

Direct Determination of the Phase Distributions of Semi-Volatile Polycyclic Aromatic Hydrocarbons Using Annular Denuders

L.A. Gundel, V.C. Lee, K.R.R. Mahanama, R.K. Stevens,
and J.M. Daisey

June 1994

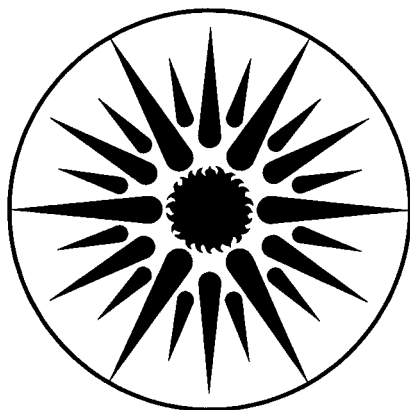

ENERGY & ENVIRONMENT
DIVISION

REFERENCE COPY
Does Not
Circulate

Blacksburg Library

Copy 1

LBL-34862

DISCLAIMER

This document was prepared as an account of work sponsored by the United States Government. While this document is believed to contain correct information, neither the United States Government nor any agency thereof, nor The Regents of the University of California, nor any of their employees, makes any warranty, express or implied, or assumes any legal responsibility for the accuracy, completeness, or usefulness of any information, apparatus, product, or process disclosed, or represents that its use would not infringe privately owned rights. Reference herein to any specific commercial product, process, or service by its trade name, trademark, manufacturer, or otherwise, does not necessarily constitute or imply its endorsement, recommendation, or favoring by the United States Government or any agency thereof, or The Regents of the University of California. The views and opinions of authors expressed herein do not necessarily state or reflect those of the United States Government or any agency thereof, or The Regents of the University of California.

Lawrence Berkeley Laboratory is an equal opportunity employer.

DISCLAIMER

This document was prepared as an account of work sponsored by the United States Government. While this document is believed to contain correct information, neither the United States Government nor any agency thereof, nor the Regents of the University of California, nor any of their employees, makes any warranty, express or implied, or assumes any legal responsibility for the accuracy, completeness, or usefulness of any information, apparatus, product, or process disclosed, or represents that its use would not infringe privately owned rights. Reference herein to any specific commercial product, process, or service by its trade name, trademark, manufacturer, or otherwise, does not necessarily constitute or imply its endorsement, recommendation, or favoring by the United States Government or any agency thereof, or the Regents of the University of California. The views and opinions of authors expressed herein do not necessarily state or reflect those of the United States Government or any agency thereof or the Regents of the University of California.

**DIRECT DETERMINATION OF THE PHASE
DISTRIBUTIONS OF SEMI-VOLATILE POLYCYCLIC
AROMATIC HYDROCARBONS USING ANNULAR DENUDERS**

Lara A. Gundel,¹ Victor C. Lee,¹ Kariyawasam R.R. Mahanama,¹
Robert K. Stevens,² and Joan M. Daisey¹

¹Indoor Environment Program
Energy and Environment Division
Lawrence Berkeley Laboratory
University of California
Berkeley, California 94720

²Source Apportionment Branch
Atmospheric Research and Exposure Assessment Branch
United States Environmental Protection Agency
Research Triangle Park, North Carolina 27711

June 1994

This work was supported by Grant number 5-R01-HL42490 from the National Heart Lung and Blood Institute, Public Health Service, Department of Health and Human Services, by the Atmospheric Research and Exposure Assessment Laboratory, Office of Research and Development, U. S. Environmental Protection Agency, and by the Director, Office of Energy Research, Office of Health and Environmental Research, Human Health and Assessments Division, U. S. Department of Energy, under Contract No. DE-AC03-76SF00098.

DIRECT DETERMINATION OF THE PHASE DISTRIBUTIONS OF SEMI-VOLATILE POLYCYCLIC AROMATIC HYDROCARBONS USING ANNULAR DENUDERS

Lara A. Gundel,¹ Victor C. Lee,¹ Kariyawasam R.R. Mahanama,¹ Robert K. Stevens,² and Joan M. Daisey¹

¹Indoor Environment Program, Energy and Environment Division, Lawrence Berkeley Laboratory, University of California, Berkeley, California 94720

²Source Apportionment Branch, Atmospheric Research and Exposure Assessment Branch, United States Environmental Protection Agency, Research Triangle Park, North Carolina 27711

ABSTRACT

An annular denuder-based sampler, here called the integrated organic vapor/particle sampler (IOVPS), has been developed for direct determination of both gas and particulate semi-volatile organic species. The IOVPS uses a cyclone inlet for removal of particles greater than 2.5 micrometers (D50) from the airstream, followed by two or three sandblasted glass annular denuders coated with ground particles of an adsorbent resin. The denuders trap the gas phase species of interest before the airstream passes through a filter and a backup denuder. Extracts of the denuders and filters are analyzed for the semi-volatile species of interest. The IOVPS has been tested and validated for sampling semi-volatile polycyclic aromatic hydrocarbons (PAH) in indoor laboratory room air and environmental tobacco smoke (ETS). Ground XAD-4 was the adsorbent for these initial studies. Gas- and particulate-phase concentrations of semi-volatile PAH are presented for these two environments. The new sampler provides the means for directly determining phase distributions of PAH and other classes of semi-volatile organic species, rather than by difference or by techniques that are subject to large positive and negative artifacts. For example, the results obtained with the IOVPS indicate that the volatilization artifact ("blow-off") from particulate PAH collected in indoor laboratory room air with a conventional filter-sorbent bed sampler at face velocity of 33 cm sec⁻¹ led to three-fold underestimation of the particulate fractions of phenanthrene, pyrene and chrysene. Phase distributions for PAH in ETS are also reported here.

INTRODUCTION

Accurate measurements of gas and particle phase distributions of semi-volatile organic compounds such as polycyclic aromatic hydrocarbons (PAH) in indoor air and environmental tobacco smoke (ETS) are needed in order to assess their health effects since lung deposition patterns differ between the gas and particulate phases (National Research Council, 1986). Similarly, environmental fates of

semi-volatile organic species are phase-dependent because atmospheric reactions and transport and deposition processes differ for gaseous and particulate semi-volatile species (Bidleman, 1988). Understanding the contribution of organic species to visibility degradation requires accurate phase distribution data (Eatough *et al.*, 1993). Pollutant control strategies are also phase-dependent (Flagan and Seinfeld, 1988).

Most phase distribution measurements have been made by determining concentrations of particulate-phase semi-volatile organic species from filters that are followed by adsorbents: either polyurethane foam (Yamasaki *et al.*, 1982; Ligocki and Pankow, 1989; Cotham and Bidleman, 1992), macroreticular polymeric resin beads such as Tenax (Van Vaeck *et al.*, 1984), XAD-2 (Kaupp and Umlauf, 1992; Salomaa *et al.*, 1988) and XAD-4 (Loiselle *et al.*, 1991), or a combination of adsorbents (Pankow *et al.*, 1994). Gas-phase concentrations have been determined from the material retained by the adsorbents. Since such sorbent beds follow filters, desorption of semi-volatile compounds from the particles on the filters, *i.e.*, negative particulate-phase artifacts, (Pupp *et al.*, 1974; Della Fiorentina *et al.*, 1975; Van Vaeck *et al.*, 1984; Miguel and De Andrade, 1986) or adsorption of gases by the filter materials, *i.e.*, positive particulate-phase artifacts, (Stevens *et al.*, 1980; Appel *et al.*, 1989; McDow and Huntzicker, 1990) can lead to incorrect measurements of gas- and particulate-phase concentrations. Considerable experimental (Della Fiorentina *et al.*, 1975; McDow and Huntzicker, 1990; Ligocki and Pankow, 1989; Storey and Pankow, 1992; Cotham and Bidleman, 1992) and theoretical effort (Junge, 1977; Pankow, 1987, 1992) has been expended to understand and correct for these vaporization and condensation effects.

Phase distributions of semi-volatile species depend not only on vapor pressures (Pupp *et al.*, 1974) and temperature (Keller and Bidleman, 1984; Cotham and Bidleman, 1992), since vapor pressure is a function of temperature, but also on sampling conditions such as the face velocity (Della Fiorentina *et al.*, 1975; McDow and Huntzicker, 1990) and sampling duration (Della Fiorentina *et al.*, 1975). This is clear from measurements of organic carbon collected on back-to-back filters (Appel *et al.*, 1989; McDow and Huntzicker, 1990) and aliphatic infrared C-H absorbance indices for filter-collected ambient organics (Della Fiorentina *et al.*, 1975). When exposed to high volumes of organic-laden gas the filter material apparently acts as an adsorbent. Under some conditions species that evaporated from particles may adsorb on or coat the filter material and enhance its trapping capacity for gas-phase organics (Cotham and Bidleman, 1992; Eatough *et al.*, 1993).

Denuder technology provides a less artifact-encumbered approach to accurate determination of phase distributions of semi-volatile species because the gas phase is collected before the particulate phase. Large particles are typically removed from the airstream by a size-selective inlet that is followed by a surface which retains gas-phase species but does not influence particle transport to a downstream filter. A sorbent or denuder after the filter can collect any material desorbed from the filter. However, artifacts could originate from less than 100% gas sorption or particle transmission by the denuder section. Recent studies have used two or more sampling trains for each measurement (Lane *et al.*, 1988; Coutant *et al.*, 1988; Eatough *et al.*, 1989, 1993), one with no denuder, dedicated to measurement of the total concentration of the analytes. The other sampling train (with denuder) was used to determine the particulate-phase concentration. Gas-phase concentrations were

calculated from the difference of the total and particulate concentrations. Such denuder difference methods have been used for semi-volatile PAH (Coutant *et al.*, 1988, 1992; Lane and Johnson, 1993), organochlorine pesticides (Lane *et al.*, 1992), and other organic species (Eatough *et al.*, 1989, 1993). Since they require paired samplers, precision may suffer. The number of sources of error are essentially doubled by using two sampling trains. The main stumbling block to direct determination of gas-phase concentrations with denuders has been the impossibility of determining the gas-phase concentrations from the denuders because of contamination by denuder coating materials or adhesives (Coutant *et al.*, 1988) or the difficulty of removing the adsorbed species from the coating (Eatough *et al.*, 1993). Recently a diffusion denuder coated with a nonpolar gas chromatographic stationary phase has been used for direct determination of gas-phase semi-volatile organics (Krieger and Hites, 1992, 1994). Turpin *et al.* (1993) recently tested a novel design for a diffusion separator that allows direct artifact-free determination of the gas phase of an airstream, but it has not yet been used for ambient sampling.

The work reported here describes a new integrated organic gas-particle sampler (IOVPS), based on an annular denuder that has been coated with the adsorbent resin XAD-4 which strips the gas-phase species from the air stream before collection of the particles on a filter. A second filter and denuder or sorbent bed can be used downstream of the filter to assess "blow off" or volatilization loss of semi-volatile species from the particles. Concentrations of the species of interest are determined in separate extracts of the denuders and filters.

XAD-4 was chosen as the adsorbent for development and validation of the IOVPS not only because of this laboratory's experience using it for sorbent bed sampling of indoor PAH (Offermann *et al.*, 1991), but also because of its high surface area ($725 \text{ m}^2 \text{ g}^{-1}$) (Rohm and Haas Co, 1993). An additional consideration was the possibility of using a single XAD-4-coated IOVPS for both simultaneous determination of nicotine and PAH, as has been reported for a conventional sorbent bed sampler (Chuang *et al.*, 1990). Because the polystyrene-divinylbenzene copolymers such as XAD-2 and XAD-4 have also been used for collection of pesticides (Seiber *et al.*, 1990; Schomburg *et al.*, 1991; Kaupp and Umlauf, 1992), dioxins (Wagel *et al.*, 1989; Lebel *et al.*, 1990), polychlorinated biphenyls (Wagel *et al.*, 1989; Kaupp and Umlauf, 1992) and other organic species (Noll and Sarlis, 1988; Levin *et al.*, 1988), their success in the IOVPS could find other useful applications where accurate determinations of phase distributions are necessary. The success of the IOVPS depends heavily on the fact that sufficient ground XAD-4 resin adheres to sandblasted glass and is resistant to removal by handling, solvent washing and air sampling. The coating mass on a commercially-available glass denuder was sufficient to trap detectable amounts of a wide range of gas phase semi-volatile PAH from the relatively clean air of a laboratory room in as little as 3 hours.

This article describes the sampler, evaluates its performance for varying conditions of flow rate and sampling duration, compares the performance of the IOVPS to a sorbent bed sampler, and reports concentrations and phase distributions of several semi-volatile PAH in indoor air and environmental tobacco smoke.

EXPERIMENTAL SECTION

Preparation of the integrated organic gas particle sampler. The IOVPS has been used in two configurations. Figure 1a shows three denuder sections between the cyclone (for removal of particles of greater than 2.5 micrometer in diameter at 10 Lmin^{-1}) and filter holder. This configuration was used to evaluate the capacity of denuder section(s) for gas-phase PAH as a function of flow rate and sampling time. The IOVPS sampled indoor laboratory room air in these experiments. As the emphasis was on evaluation of its collection of gas-phase components, no sorbent or denuder was usually used downstream of the filter. The filter holder was loaded with one or two Teflon-coated glass fiber (TCGF) filters (47 mm diameter) that had been pre-cleaned by sonication in dichloromethane and methanol before use. Fig. 1b shows the configuration used to sample ETS for determination of the phase distribution. Two denuders were used between the cyclone and filter pack; the third denuder followed the filter pack. Two filters were used in the filter pack when sampling ETS. This configuration was also used in two experiments that sampled indoor laboratory room air.

The cyclone, annular denuders and filter packs were purchased from University Research Glass, Carrboro, NC (denuder part number 2000-30B with 220 mm length). The outer diameter of the annulus was 2.4 cm; the annulus width was 1.0 mm (Fig. 2). The coated length of each denuder section was 18.5 cm. The ends of the glass tubes had #30 threads. The individual components of the IOVPS were connected to each other by threaded couplers that used Teflon-coated gaskets. (The gaskets were examined for deformation after use and replaced when deformation was visible, to avoid introduction of turbulence or leaks between denuder sections during sampling.) The edges of the TCGF filters usually frayed when the IOVPS was disassembled. The O-ring used for sealing the filter in the filter pack often stuck to the filter at several points. The particle deposition area was not affected, but filter mass could not be accurately determined for affected filters. A different filter, such as the 2-micron Teflo (Gelman Sciences), could be used to avoid this problem.

Before coating the denuder, macroreticular styrene-divinylbenzene polymer resin XAD-4 beads (average diameter 0.8 mm, purchased from Alltech Associates, Deerfield IL) were ground in an agate ball mill with agate balls using a planetary grinder (Fritsch Pulverisette type 0.5.101) at high speed for 6-21 hours. The resulting white powder was sonicated for 20 min in dichloromethane followed by methanol to remove contaminants. The clean powder was filtered through Teflon filters of nominal pore size 0.5 μmeters (type FHUP, Millipore Corporation) to remove very fine particles. The filtrate was discarded. (Otherwise, after air sampling, some of the fine XAD-4 particles were later extracted from the coated denuder and clogged the inlet of the analytical instrumentation.) The sandblasted surfaces of the annular denuder sections were coated with XAD-4 that was applied from an n-hexane (spectrophotometric grade) slurry. No adhesive was used. The coating was then removed by sonication from the inside ends of each denuder section, up to just past the two small epoxy stand-offs between the two parts of the annular denuder, found at each end of the section. (Otherwise XAD-4 powder could flake off the stand-offs during sampling and be detected as a faint yellowish-white deposit in the central area ($\sim 1 \text{ cm}^2$) of the filter used to collect the airborne particles.) After coating, the denuders were rinsed with hexane to remove any loose particles, dried

with nitrogen, weighed, capped by screw caps with Teflon liners and stored at room temperature. Precleaning and storage procedures were intended to minimize introduction of organic artifacts from the sampler materials or room air.

Typical single-channel denuder coating mass was 10-20 mg, as determined by weighing the whole denuder section to the nearest 0.1 mg with an analytical balance. After cleaning and recoating, individual denuder coating mass was reproducible to within 2 mg. (Some of the denuders that were used in the initial stages of the field test [described below] were too long to fit in the compartment of the analytical balance and had to be weighed on a pan balance to the nearest 0.01 g.) The surface coverage corresponded to roughly 0.1 mg cm⁻². Tenax-GC, XAD-2, XAD-7, XAD-16, several ion-exchange resins and Carbotrap were also ground and applied to denuder sections. Tenax-GC, XAD-2, XAD-4 and XAD-16 showed promise as denuder coatings, but these coatings have not yet been used for air sampling. Polystyrene-divinylbenzene polymers that contained polar functional groups (cation and anion exchange resins) did not adhere well to the denuder surfaces.

Electron microscopy. One annular denuder was intentionally shattered and examined by electron microscopic analysis. A 3 mm x 3 mm fragment was coated. It had a visible thin coating of white powder that was not dislodged when the fragment was tapped gently. A similar uncoated fragment was also selected for comparison. The glass fragments were analyzed at the US Environmental Protection Agency Scanning Electron Microscope Laboratory in Research Triangle Park, North Carolina, using an Amray Model 1000 scanning electron microscope, an analog instrument with manual stage control and resolution of about 70 nm at 30 keV. The samples were scanned at 500 and 2000 times magnification.

Field testing. The IOVPS was evaluated by sampling indoor laboratory air at room temperature (about 21°C). Freshly-coated denuders were used for each field test. Two freshly-coated denuders were also used as blanks for each experiment. The room was free of indoor combustion sources. Sampling was done at 5, 10 and 20 L min⁻¹ for 3 and 6 hours, using sampling trains consisting of three single-channel annular denuders and a filter in the configuration shown in Figure 1a. The residence times per denuder section for these flow rates were 0.27, 0.15 and 0.075 sec, respectively. Filter face velocities were 8, 17 and 33 cm sec⁻¹, respectively. One experiment was done at 20 L min⁻¹ for 22 hours. Separate clean components were used for each condition. The exposed denuders were refrigerated at 4°C before analysis if the extraction could not be carried out immediately. (Freezer storage at -20°C caused the denuders to crack at the epoxy joints.) The filters were stored in the freezer before analysis.

Parallel sampling was done using filter-sorbent samplers similar to those described by Loiselle *et al.* (1991), except that the filter holder was stainless steel, and the flow rate was 10 or 20 L min⁻¹. The filter was followed by a sorbent bed filled with between 0.15 and 2.5 g unground XAD-4 resin beads. The XAD-4 resin had been cleaned and dried (Loiselle *et al.*, 1991), but was sonicated sequentially in cyclohexane and methanol immediately before use. The sorbent bed blanks and field samples had the same preparation, storage, extraction and analysis history, except for air sampling. Problems with high PAH concentrations in the sorbent bed blanks compromised the data from several

preliminary attempts at parallel sampling that are not reported here. Other workers have reported difficulty with internal standard recovery (Wong *et al.*, 1991), high blanks (Hunt and Pangaro, 1982) and storage-dependent blanks (Junk *et al.*, 1974) for XAD-4 resin beds.

Simulated environmental tobacco smoke was sampled at 16 and 20°C in a sealed 36 m³ environmental chamber (0.03 air exchange per hour). A smoking machine (a laboratory-fabricated 12-port programmable auto-igniting and extinguishing cigarette holder attached to an Arthur D. Little, Inc. smoking machine) was used in the center of the room, about 1.5 m above the floor. Three reference cigarettes, Kentucky reference type 1R4F, were machine-smoked sequentially at one 35 mL puff per minute using a standard puff profile. The mainstream smoke was ventilated outside the chamber, while the sidestream smoke was emitted into the chamber. For replication studies two IOVPSs with freshly-coated denuders were placed about 0.7 m apart, with their inlets about 0.7 m above the floor. The samplers operated for one hour at 5 L min⁻¹ starting 20 minutes after the last cigarette was extinguished. In a separate experiment just one IOVPS operated under the same conditions.

Extraction. Denuders, filters and sorbent beds were extracted individually by sonication at 50°C (capped denuders and sorbent beds) or 70°C (filters) with high purity (liquid chromatography/pesticide analysis grade, low ultraviolet absorbance) cyclohexane. Deuterated fluoranthene and phenanthrene were added at the time of extraction as internal standards to correct for any losses during sample preparation. Each extract was passed through a Teflon filter (unlaminated, FHUP, Millipore Corp.) and then a silica solid-phase extraction column. The silica (500 mg) columns were assembled in 5-mL glass syringe barrels with pre-fired (800°C) quartz filters at each end of the silica. Before analysis the solvent was exchanged to acetonitrile by evaporating the cleaned cyclohexane extract on a silica column (200 mg) at room temperature and eluting with acetonitrile. Final sample volume was between 250 and 1000 µL. Two unexposed coated denuders and pre-extracted filters were analyzed as blanks for every field test. (Each denuder was analyzed separately.)

Analysis. The dual-fluorescence detector method developed for particulate PAH in ETS by Mahanama *et al.* (1994) was adapted for analysis of semi-volatile PAH from naphthalene to chrysene (Gundel *et al.*, 1994). A Hewlett-Packard high performance liquid chromatograph Model 1090 M was used with a Vydac 201TP52-15 cm microbore column. The injection volume 5 µL. The detection and quantitation limits for both the gas and particle phases, derived from analysis of blanks, are shown in Table 1. Recovery of both internal standards from denuder and filter extracts was the same and averaged 70 ± 19%. The same average recovery of internal standards was observed for denuders and filters used as blanks. PAH concentration data were corrected for incomplete recovery.

RESULTS

Evaluation of the coating. Figure 3 shows scanning electron photomicrographs of the annular denuder fragments. Analysis of the particle size distribution of the coated fragment showed that the coating was composed of particles with median and average diameters of 0.7 and 0.9 micrometers, respectively. The geometric mean was 0.75 micrometers, and the geometric standard deviation was 1.8. The coating was stable during sampling at flow rates up to 20 L min^{-1} for 24 hours, as assessed by visual inspection of black afterfilters. Inspection of Teflon filters that had been used to filter denuder extracts showed that the coating was not removed by static solvent extraction (two rinses of the intra-annular space) at 45°C . About half the coating was removed by sonication in cyclohexane at 50°C ; the rest was removed by sonication in acetonitrile or ethyl acetate at room temperature. The denuders were routinely cleaned (to remove the coating) after extraction and recoated before the next use. Coating mass was reproducible to within two mg for recoating of individual denuders.

Efficiency for collection of gas-phase PAH. The efficiency of a sorbent-based sampler depends on the concentrations of the sorbed species in the airstream (Adams et al., 1977). At low concentrations the volumetric capacity depends on the total volume of air sampled and is independent of the gas-phase concentrations of the sorbed species. The holding power or efficiency of the trap is limited by the amount of air necessary to elute or displace adsorbed material from the surface, as occurs in gas-solid chromatography. At higher inlet gas-phase concentrations the adsorption sites could be filled before the volumetric capacity is exceeded because the weight capacity of the sorbent has been reached. The gas-phase PAH concentration data obtained from sampling indoor air under various conditions have been used to estimate these limits for the IOVPS. The goal is bracketing its useful operating range rather than investigating the sorption mechanism in detail.

We assumed that the volumetric capacity V_g for a particular PAH had been exceeded for total air volumes for which the first denuder collected less than 90% of that PAH. (The concentrations of all PAH were determined separately in each denuder section.) The percentages of naphthalene (and its methyl derivatives), fluorene and phenanthrene found on the first of the three serial denuders are shown in Table 2. V_g is about 2 m^3 per denuder section for these compounds. The data indicate that V_g is somewhat higher for sampling at 10 L min^{-1} for 3 hours, compared to sampling at 5 L min^{-1} for 6 hours. Apparently greater displacement or elution of PAH occurred at the combination of lower flow rate and longer sampling time.

Lower limits to the weight capacity of the ground XAD-4 for several PAH were estimated from the amounts of these compounds collected on the first and sometimes second of three denuders in series under conditions where breakthrough was observed. The XAD-4 coating mass was measured for each denuder section. For the purposes of the estimate, breakthrough was assumed to have occurred when the amount trapped on the next (downstream) denuder was more than 10% of the total found on all three denuder sections. Based on this operational definition, breakthrough of naphthalene onto the second denuder was seen at 20 L min^{-1} for 3 hours of sampling and at 10 L min^{-1} for 6 hours of sampling. Breakthrough of naphthalene from the second denuder to the third denuder section

occurred when the IOVPS operated at 20 L min⁻¹ for 6 and 22 hours. Under those conditions naphthalene migrated axially along the denuder sections during the extended sampling period, so the volumetric capacity was exceeded. Breakthrough was not observed at 20 L min⁻¹ for four-ring PAH. For the other PAH, breakthrough occurred only when sampling at 20 L min⁻¹ for 3 hours or longer, and the first denuder may not have been saturated under those conditions.

The weight capacity of ground XAD-4 for naphthalene, fluorene and phenanthrene (sampled together with other PAH) in indoor air was found to be (\pm standard deviation; n = the number of observations) 57 ± 16 (n = 8), $> 4.3 \pm 1.3$ (n = 3), and $> 7.7 \pm 3.4$ (n = 5) ng mg⁻¹ XAD-4, respectively. (The high standard deviations reflect the fact that some of the denuders were too long to fit within the weighing compartment of the analytical balance and had to be weighed on a pan balance to the nearest 10 mg. Therefore, the coating mass was known to only one significant figure in those cases.) The value found here for naphthalene is about 3 times higher than estimated from breakthrough experiments for an XAD-4 resin sorbent sampler (Offermann *et al.*, 1990). A typical denuder section can trap about 800 ng naphthalene, 50 ng fluorene and 100 ng phenanthrene.

The performance of the IOVPS can also be assessed by using the models for annular denuder efficiency developed by Possanzini *et al.* (1983) and Coutant *et al.* (1989). Both models predict that, for sufficient denuder length, the ratio of outlet to inlet concentration for a trapped component of the airstream follows an exponential dependence on the ratio of denuder length to the total air flow. Possanzini's model applies to a surface coating that irreversibly reacts with the gas-phase component of interest. Coutant *et al.* (1989) consider denuder performance when the reaction or adsorption probability is less than one for each collision of the gas-phase component with the denuder coating. For a single denuder section of length L the outlet concentration C_{out} has been reduced from the inlet concentration C_{in} by the amount trapped on the denuder surface, per unit volume of air. The efficiency is $1 - (C_{out} / C_{in})$. For a denuder with several sections the efficiency of the first section E₁ can be approximated by assuming that C_{in} is the sum of the amounts per m³ found on each section (C₁, C₂, ... C_n where n is the number of denuder sections). The outlet concentration after the first section is the difference between C_{in} and C₁. Therefore, the efficiency of one section is

$$(1) E_1 = 1 - \frac{C_{out}}{C_{in}} = \frac{C_1}{C_{in}}$$

and the efficiency of two sections is

$$(2) E_2 = 1 - \frac{C_1 + C_2}{C_{in}}$$

Fig. 4 shows semi-logarithmic plots of C_{out}/C_{in} for collection of several PAH versus the ratio of denuder length to the volume of air that passed through the IOVPS. The coated length L₁ or L₁ + L₂ was used for the first and second sections, respectively. Data are shown for naphthalene, 1-methylnaphthalene, fluorene and phenanthrene sampled in indoor air at flow rates between 5 and 20 L min⁻¹ for 3 and 6 hours. The solid and open symbols correspond to the length of one and two sections, respectively. The line drawn in each section of the figure corresponds to a theoretical

efficiency of 90% for each section. Besides confirming the volumetric gas capacity of 2 m³ per denuder section for 90% efficiency, the data indicate that C_{out}/C_{in} is an exponentially decaying function of the ratio of denuder length to air volume, consistent with the models of Possanzini *et al.* (1983) and Coutant *et al.* (1989). Efficiency improved as the molecular weight increased from naphthalene to fluorene while vapor pressure decreased.

Particle losses. Particle losses were assessed by visual examination of the used XAD-4 coatings after they had been stripped from the denuder surfaces by sonication and collected on Teflon filtration membranes. When ambient air particles were intentionally admitted at loose couplers between denuder sections, the used XAD-4 denuder coatings had a light gray coloration from ambient black (elemental) carbon. Under those conditions the black ambient particles hit the denuder walls because of increased turbulence at the leak site. Under normal use the stripped coatings were pale yellowish white. Another symptom of particle loss in those experiments was that concentrations of benz(a)anthracene and chrysene on the affected denuder section were higher than observed on the first (upstream) denuder. Higher molecular weight PAH would also be observed if substantial particle loss occurred. However, no particle losses were observed during the sampling of indoor laboratory room air or environmental tobacco smoke under the usual sampling conditions described earlier.

Ye *et al.* (1991) evaluated losses of neutral and charged polydisperse NaCl particles during passage through uncoated annular denuders with the same dimensions as used in this study. At a flow rate of 10 L min⁻¹ they found that about 1% of neutral and 6% of singly charged particles with diameters of 0.075 μm and larger were lost per annular denuder section. Losses increased with decreasing particle size, up to about 12% per section for neutral particles of diameter 0.0075 μm.

Reproducibility. Table 3 shows PAH concentrations obtained from two co-located IOVPSs that simultaneously sampled simulated environmental tobacco smoke. The standard deviation σ was estimated from the difference using the procedure described by Wilson (1952). The coefficient of variation (σ/mean) has been calculated from the standard deviation. For extracts of the upstream denuder the coefficient of variation ranged from 7% for 1-methylnaphthalene to 39% for pyrene and averaged 17%. Possible sources of the observed variability include heterogeneity in room concentrations of PAH in the room air, and errors in determination of flow rates, fluorescence intensities of the PAH and recoveries of the internal standards. The high value for pyrene could be due to its co-elution with one of the methyl derivatives of phenanthrene. The fluorescence excitation and emission wavelengths for pyrene were chosen from the edges of its response envelope so that the methylphenanthrene interference was minimized. The poor quantum yield for pyrene under that condition probably contributed to its high variability. The higher-than-average coefficient of variation for biphenyl may be due to its co-elution with 2-methylnaphthalene which was always found at higher concentration than biphenyl. Most of the semi-volatile PAH were not detected in the particle phase. However, the four that were detected had an average coefficient of variation of 9%.

Comparison to filter-sorbent bed sampling. Conventional samplers were constructed with a 47-mm diameter filter followed by a sorbent trap that contained between 0.15 and 2.5 g cleaned

unground XAD-4 resin beads (20-60 mesh) (Loiselle *et al.*, 1991). In several experiments the filter-sorbent bed sampler was co-located indoors with the IOVPS (in the configuration shown in Fig. 1a) and operated for the same time and at the same flow rate. Because the two sampler types could yield different phase distributions of all but the most volatile PAH (due to the possibility of both positive and negative artifacts expected from the conventional sampler), only species more volatile than phenanthrene (*i.e.*, the naphthalenes, acenaphthene, acenaphthylene and fluorene) would be expected to be trapped with the same efficiency by both sampler types. Gas phase concentrations of these PAH were determined from the co-located samplers.

Comparison data from sampling indoor laboratory room air on two different days are presented in Table 4 for two flow rates, 10 and 20 L min⁻¹. Three-hour sampling periods were used for each experiment. The data indicate that the IOVPS traps and recovers semi-volatile PAH quantitatively when its capacity is not exceeded. At 10 L min⁻¹ the denuders and sorbent bed trapped the same amounts of semi-volatile PAH. The ratio of detectable PAH measured with the denuders to PAH collected by the sorbent bed was 1.00 ± 0.10. Therefore, the IOVPS-derived gas-phase PAH concentrations agreed with the conventional sampler results at this flow rate and sampling time. The data show no apparent sampling artifacts.

Our indoor air sampling with the IOVPS for three hours at 20 L min⁻¹ yielded gas-phase PAH concentrations (summed from three serial denuder sections) that averaged 78 ± 13% of those derived from the sorbent bed. The denuder-derived PAH concentrations averaged 73 ± 9% of the sorbent-derived concentrations for PAH more volatile than phenanthrene (the naphthalenes, acenaphthene, acenaphthylene, biphenyl and fluorene). The capacity limits for these species had been exceeded under the conditions of this experiment (Fig. 4). Denuder-derived concentrations for phenanthrene and the less volatile PAH from the IOVPS averaged 84 ± 13% of the sorbent-derived values for the same experiment. However, particulate phenanthrene and less volatile species may have been subject to "blow off" artifacts that increased the apparent sorbent bed concentration. Since the data presented in Fig. 4 indicate that phenanthrene was collected in the first two of three denuder sections with > 90% efficiency under the sampling conditions of this experiment, operation with three serially-connected sections is expected to lead to > 99% efficiency.

Phase distributions and "blow-off" of PAH in indoor laboratory room air. Table 5 shows the phase distribution data for phenanthrene, pyrene and chrysene collected by the two samplers at 20 L min⁻¹, corresponding to filter face velocity of 33 cm sec⁻¹. Particulate fractions determined from the filter-sorbent bed sampler were smaller for all three PAH than from the IOVPS. The difference decreased as the PAH volatility decreased from phenanthrene to chrysene. Since the denuders have higher efficiency for the less volatile PAH, the lower gas-phase and higher particle-phase concentrations measured with the denuder for fluoranthene, pyrene and chrysene are consistent with "blow-off" artifact from the particle-loaded filter in the filter-sorbent bed sampler. For the IOVPS data shown in Table 5, a post-filter denuder or sorbent was not used, so correction for a possible IOVPS filter-associated blow-off artifact could not be made.

Two other parallel sampling experiments also yielded pre-sorbent bed filter samples that had lower PAH concentrations than the filter samples obtained with the IOVPS. Post-filter denuders were not used with the IOVPS in these experiments, so blow-off-artifact from the IOVPS-collected particles could not be assessed. However, in a separate experiment using the configuration shown in Fig. 1b at face velocity of 17 cm sec^{-1} (10 L min^{-1} , 6 hours) for which the IOVPS particle-laden filter could not be analyzed, detectable but small amounts of phenanthrene, pyrene, benz(a)anthracene and chrysene were found on a post-filter denuder. Since these compounds were not detected on the second denuder (i.e., gas-phase adsorption in the pre-filter denuder section was complete with no breakthrough), they must have desorbed from the particles during sampling.

PAH concentrations in indoor air and simulated ETS. To illustrate the use of the IOVPS for determination of PAH concentrations, Table 6 summarizes the gas phase concentration data obtained during the validation study for indoor air with no combustion sources and simulated environmental tobacco smoke. The ranges and average concentrations are listed. PAH concentrations were typically at least three times higher in ETS than in the relatively clean room air of the laboratory. The concentration ranges are similar to those reported by other workers for indoor air with ETS (Offermann *et al.*, 1991; Guerin *et al.*, 1992).

Phase distributions for polycyclic aromatic hydrocarbons in ETS. Table 7 presents phase distribution data for simulated environmental tobacco smoke sampled at 16°C . Both gas and particle phase data are average values for the co-located samplers when the IOVPS operated in the 36 m^3 chamber for one hour at 5 L min^{-1} with face velocity = 8 cm sec^{-1} . None of the more volatile PAH from naphthalene to anthracene were detected on the ETS particles, but fluoranthene and pyrene were found in both phases. Very little benz(a)anthracene and chrysene were found in the gas phase for ETS. Generally, the particulate fraction increased as molecular weight increased and vapor pressure decreased (Pupp *et al.*, 1974; Sonnefeld *et al.*, 1983). No detectable amounts of PAH were found on the second filters or the post-filter denuders. No "blow-off" of particulate PAH onto the backup filter substrate or downstream denuder was observed for this experiment. In a separate experiment using the same IOVPS configuration but with the chamber at 20°C , fluoranthene, pyrene and chrysene were detected on the post-filter denuder, not on the backup filter, indicating that some blow-off occurred. The amounts found on the post-filter denuder averaged 16% of the total particulate PAH concentrations. The single-section capacity limits were not exceeded, since no PAH were detected on the second (pre-filter) denuder in the experiment at 20°C .

The particulate fractions were much higher for ETS than for indoor air with no combustion sources (Table 5). Since the face velocities were different, interpretation of differences in phase distributions for the two environments must be made cautiously. However, lower fractions of particulate-phase PAH in the absence of ETS are consistent with the presence of "dried out" aged ambient particles, compared to oily ETS particles that were freshly emitted. "Blow-off" of semi-volatile PAH from the indoor particles would be expected to occur to a larger extent at the higher face velocity and longer sampling time used in the indoor sampling. However, the phase distributions obtained for PAH in indoor air with the two sampler types do not overlap the range observed for the same PAH in ETS.

DISCUSSION

Evaluation of the IOVPS. This report presents the first direct denuder-based phase distribution measurements for PAH in indoor air and simulated environmental tobacco smoke. Earlier work with denuders for PAH and other organics has depended on difference methods that require more sampling components and are subject to larger uncertainty. Direct determination of gas phase concentrations of PAH was possible with the IOVPS because the species adsorbed on the coated surfaces of the denuders were extracted and analyzed. Particulate phase concentrations were determined using established analytical procedures, and a post-filter denuder assessed amounts of species volatilized from the collected ETS particles. Only one sample train was necessary for a complete measurement.

The IOVPS is much less prone to sampling artifacts than conventional filter-sorbent bed sampling because the gas phase is trapped before the particles are collected. However, volatilization losses of semi-volatile species from particles are possible if the IOVPS is operated at a high face velocity. This negative artifact can be assessed by trapping desorbed species on another denuder or sorbent downstream of the filter. Adsorption by the filter medium can also be assessed by using a backup filter behind the filter used for particle collection.

Blank problems with XAD-4 resin are well known (Junk *et al.*, 1974; Hunt and Pangaro, 1982). The problems were much less burdensome with the ground XAD-4 used in the IOVPS than with the resin beads used in the conventional XAD-4 resin bed sampler. The cleanup procedure for the ground resin was much simpler and faster than that recommended for polymeric resins in sorbent bed samplers (Hanson *et al.*, 1984). This is probably due to the exposure of more surface area to cleanup solvents than was possible with the resin beads. We found that the coated denuders had lower and more reproducible blanks and therefore lower limits of detection than the conventional sampler that was used in earlier studies in this laboratory (Offermann *et al.*, 1990).

The ground XAD-4 and other coating materials were much easier to handle than the unground materials because the denuders were coated from slurries that controlled the distribution of the resin. The unground XAD-4 stuck to any available surface such as beakers, scoops and aluminum foil. Configuration of the IOVPS components for sampling was also easier than for the conventional sampler because the components could be assembled by hand in the field. The coating of the denuder surfaces is stable during normal handling and sampling and can only be removed by extensive sonication. The denuder sections can also be reused after static extraction. This technique has been employed in outdoor chamber studies in which each denuder was used six times before recoating (Fan *et al.*, 1993).

The IOVPS has been developed to use hardware that has already been validated for sampling of acid gases. The sampler geometry and flow characteristics have been thoroughly investigated (Possanzini *et al.*, 1983; Vossler *et al.*, 1988; Ye *et al.*, 1991). The studies of Vossler *et al.* (1988) and Ye *et al.* (1991) used two and three denuder sections, respectively, connected serially, with the same dimensions as used here. The advantages of sampling gas phase pollutants with annular diffusion

denuders (Possanzini *et al.*, 1983) have now been extended to organic species that are adsorbed by the macroreticular resin XAD-4 and similar adsorbents. Because of the modular design of the IOVPS, the configuration of its components can be tailored for the needs of each investigation. For example, the total length of the denuder section can be adjusted by choice of the number of sections used, and different coating types could be used in the different pre-filter sections. The filter holder can contain up to 4 filters if desired. The post-denuder section can be a denuder, sorbent bed or polyurethane foam collector.

Capacity and specificity considerations. Because the available surface area of the resin beads is increased by grinding, the thinly-coated annular denuder surfaces have sufficient capacity for determination of gas-phase PAH in indoor air in as little as 1 m³ or in 0.3 m³ ETS. However, the trapping capacities of the macroreticular resins, even when ground to fine particle size and dispersed on the sandblasted surfaces of the denuders, are smaller per unit mass of adsorbent than the trapping capacities of the acidic and basic coatings used for sampling of basic and acidic gases (Possanzini *et al.*, 1983). The polystyrene-divinylbenzene adsorbent resins trap by van der Waal's attraction, capillary action and adsorbent-adsorbate pi-electron interactions (Kiselev and Yashin, 1969) that are much less powerful than the Coulombic attraction that results in chemical reaction of an acidic molecule with the basic coating. Desorption and elution may also occur during sampling if capacity limits are exceeded. Therefore, trapping equivalent numbers of molecules requires longer and/or larger denuders or longer sampling times and volumes for adsorption-based denuders than for acid-base reaction-based denuders.

To increase its capacity for outdoor sampling of air volumes larger than 4 m³, the IOVPS can be scaled up in size, using dimensions similar to those of the denuder-based gas-and particle (GAP) sampler (Lane *et al.*, 1988), for example. The GAP sampler has roughly 20 times the surface area of the IOVPS sampler. The IOVPS could also be scaled downward in size for personal sampling or extraction and analysis in automated equipment. Coating procedures could be adapted for the denuder surfaces of other dimensions (Lane *et al.*, 1988; Koutrakis *et al.*, 1989) and geometries (Eatough *et al.*, 1989, 1993; Koutrakis *et al.*, 1993). Capacity limits for the currently-configured IOVPS require a sensitive analytical technique for the polycyclic aromatic hydrocarbons. Dual-detector fluorescence HPLC has been used quite successfully here.

Results for other adsorbents besides XAD-4 that have been ground and coated onto sandblasted glass indicate that the IOVPS could be modified for other applications. Tenax-GC, for example, coated the IOVPS well and could be used for sampling polycyclic aromatic hydrocarbons and pesticides. Because of its thermal stability, Tenax-GC could possibly be used in a miniaturized IOVPS whose denuder sections fit into the injection ports of gas-chromatographs for thermal desorption.

Significance. The chief significance of the results presented and discussed here is that phase distributions of PAH and several other classes of organic species can now be made directly, rather than by difference or by techniques that are subject to large positive and negative artifacts. The IOVPS fills a long-recognized need for denuder-based sampling methods for airborne organics. The

IOVPS is also an important contribution to lung dosimetry studies because deposition and uptake of toxic and carcinogenic species in ETS depend on their phase distribution.

SUMMARY

An annular denuder-based sampler, here called the integrated organic gas/particle sampler, has been developed for direct determination of both gas and particulate semi-volatile organic species. It has been tested and validated for sampling semi-volatile PAH in indoor air and environmental tobacco smoke. Phase distribution measurements have been obtained at two filter face velocities, 8 and 33 cm sec⁻¹. At the higher face velocity a conventional filter-sorbent bed sampler showed lower fractions of PAH in the particulate phase than the IOVPS.

ACKNOWLEDGMENTS

The authors would like to thank Hector G. Cancel-Velez, Mindi Xu and Matti Nematollahi for assistance with field sampling and R.C. Schmidt for fabrication of the smoking machine cigarette holder. Richard Kamens and Zhihua Fan assisted in performance studies. The authors thank D.J. Eatough, Zhihua Fan, A.T. Hodgson, L.M. Hildemann, Richard Kamens, D.A. Lane, R.G. Lewis and J.F. Pankow for review of the manuscript. This work was supported by Grant number 5-R01-HL42490 from the National Heart Lung and Blood Institute, Public Health Service, Department of Health and Human Services, by the Atmospheric Research and Exposure Assessment Laboratory, Office of Research and Development, U. S. Environmental Protection Agency, and by the Director, Office of Energy Research, Office of Health and Environmental Research, Human Health and Assessments Division, U. S. Department of Energy, under Contract No. DE-AC03-76SF00098.

REFERENCES

1. Adams J., Menzies K. and Levins P. (1977) Selection and evaluation of sorbent resins for organic compounds. U.S. Environmental Protection Agency Report EPA 600/7-77-044.
2. Appel B. R., Cheng W. and Salaymeh F. (1989) Sampling of carbonaceous particles in the atmosphere II. *Atmos. Environ.* **23**, 2167-2175.
3. Bidleman T. F. (1988) Atmospheric processes. *Environ. Sci. Technol.* **22**, 361-367.
4. Chuang J. C., Kuhlman M. R. and Wilson N. K. (1990) Evaluation of methods for simultaneous collection and determination of nicotine and polynuclear aromatic hydrocarbons in indoor air. *Environ. Sci. Technol.* **24**, 661-666.

5. Cotham W. E. and Bidleman T. F. (1992) Laboratory investigations of the partitioning of organochlorine compounds between the gas phase and atmospheric aerosols on glass fiber filters. *Environ. Sci. Technol.* **26**, 469-478.
6. Coutant R. W., Brown L., Chuang J. C., Riggin R. M. and Lewis R. G. (1988) Phase distribution and artifact formation in ambient air sampling for polynuclear aromatic hydrocarbons. *Atmos. Environ.* **22**, 403-409.
7. Coutant R. W., Callahan P. J., Kuhlman M. R. and Lewis R. G. (1989) Design and performance of a high-volume compound annular denuder. *Atmos. Environ.* **23**, 2205-2211.
8. Coutant R. W., Callahan P. J., Chuang J. C. and Lewis R. G. (1992) Efficiency of silicone-grease-coated denuders for collection of polynuclear aromatic hydrocarbons. *Atmos. Environ.* **26A**, 2831-2834.
9. Della Fiorentina H., De Wiest F. and De Graeve J. (1975) Determination par spectrometrie infrarouge de la matiere organique non volatile associee aux particules en suspension dans l'air-II. Facteurs influencant l'indice aliphatique. *Atmos. Environ.* **9**, 517-522.
10. Eatough D. J., Sedar B., Lewis L., Hansen L. D., Lewis E. A. and Farber R. J. (1989) Determination of semivolatile organic compounds in particles in the Grand Canyon area. *Aerosol Sci. Technol.* **10**, 438-449.
11. Eatough D. J., Wadsworth A., Eatough D. A., Crawford J. W., Hansen L. D. and Lewis E. A. (1993) A multiple-system, multi-channel diffusion denuder sampler for the determination of fine-particulate organic material in the atmosphere. *Atmos. Environ.* **27A**, 1213-1219.
12. Fan Z., Kamens R. M., Chen D., Chen S. and McDow S. (1993) Modeling the atmospheric formation and decay of gas and particle bound nitro polycyclic aromatic hydrocarbons. In *Measurement of Toxic and Related Air Pollutants*, pp. 129-134., (Proceedings of the International Symposium on Toxic and Related Air Pollutants May 4-8, 1993 Durham NC; Air and Waste Management Association, VIP-34).
13. Flagan R. C. and Seinfeld J. (1988) *Fundamentals of Air Pollution Engineering*. Prentice-Hall, Englewood Cliffs, NJ.
14. Guerin M. R., Jenkins R. A. and Tomkins B. A. (1992) *The Chemistry of Environmental Tobacco Smoke: Composition and Measurement*. Lewis, Boca Raton, 330 p.
15. Gundel L. A., Mahanama K. R. R. and Daisey J. M. (1994) Cleanup and determination of semi-volatile and particulate polycyclic aromatic hydrocarbons in environmental tobacco smoke. *Environ. Sci. Technol.* **submitted**.
16. Hanson R. L., Clark C. R., Carpenter R. L. and Hobbs C. H. (1984) Comparison of Tenax-GC and XAD-2 as Polymer Adsorbents for Sampling Combustion Exhaust Gases. In *Identification and Analysis of Organic Pollutants in Air* (edited by Keith L. H.), pp. 79-93. Butterworth, Boston.

17. Hunt G. and Pangaro N. (1982) Potential contamination from the use of synthetic adsorbents in air sampling procedures. *Anal. Chem.* **54**, 369-372.
18. Junge C. E. (1977) Basic considerations about trace constituents in the atmosphere as related to the fate of global pollutants. In *Fate of Pollutants in Air and Water Environments* (edited by Suffett I. H.), pp. 7-26. Wiley, New York.
19. Junk G. A., Richard J. J., Grieser M. D., Witiak D., Witiak J. L., Arguello M. D., Vick R., Svec H. J., Fritz J. S. and Calder G. V. (1974) Use of macroreticular resins in the analysis of water for trace organic contaminants. *J. Chromatog.* **99**, 745-762.
20. Kaupp H. and Umlauf G. (1992) Atmospheric gas-particle partitioning of organic compounds: comparison of sampling methods. *Atmos. Environ.* **26A**, 2259-2267.
21. Keller C. D. and Bidleman T. F. (1984) Collection of airborne polycyclic aromatic hydrocarbons and other organics with a glass fiber filter-polyurethane foam system. *Atmos. Environ.* **18**, 837-845.
22. Kiselev A. V. and Yashin Y. I. (1969) *Gas-Adsorption Chromatography*. Plenum, New York.
23. Koutrakis P., Fasano A. M., Slater J. L., Spengler J. D., McCarthy J. F. and Leaderer B. P. (1989) design of a personal annular denuder sampler to measure atmospheric aerosols and gases. *Atmos. Environ.* **23**, 2767-2773.
24. Koutrakis P., Sioustas C., Ferguson S., Wolfson J. M., Mulik J. D. and Burton R. M. (1993) Development and evaluation of a glass honeycomb denuder/filter pack system to collect atmospheric gases and particles. *Environ. Sci. Technol.* **27**, 2497-2501.
25. Krieger M. S. and Hites R. A. (1992) Diffusion denuder for the collection of semivolatile organic compounds. *Environ. Sci. Technol.* **26**, 1551-1555.
26. Krieger M. S. and Hites R. A. (1994) Measurement of polychlorinated biphenyls and polycyclic aromatic hydrocarbons in air with a diffusion denuder. *Environ. Sci. Technol.* **28**, 1129-1133.
27. Lane D. A. and Johnson N. D. (1993) Vapor and particle phase measurements of polycyclic aromatic compounds (PAC) in ambient air. *Polycyclic Aromatic Hydrocarbons* **13**, Supplement, 511-518.
28. Lane D. A., Johnson N. D., Barton S. C., Thomas G. H. S. and Schroeder W. H. (1988) Development and evaluation of a novel gas and particle sampler for semivolatile chlorinated organic compounds in ambient air. *Environ. Sci. Technol.* **22**, 941-947.
29. Lane D. A., Johnson N. D., Hanley M.-J. J., Schroeder W. H. and Ord D. T. (1992) Gas- and Particle-Phase Concentrations of alpha-Hexachlorocyclohexane, gamma-Hexachlorocyclohexane, and Hexachlorobenzene in Ontario Air. *Environ. Sci. Technol.* **26**, 126-133.

30. Lebel G., Williams D. T., Hollebhone B. R., Shewchuk C., Brownlee L. J., Tosine H., Clement R. and Suter S. (1990) Analysis of polychlorodibenzo-p-dioxins in raw and treated waters. II. Optimization of an XAD-2 resin column methodology. *Intern. J. Environ. Anal. Chem.* **38**, 21-29.
31. Levin J. O., Andersson K. and Karlsson R. M. (1988) Solid sorbent sampling and chromatographic determination of glycidyl ethers in air. *J. Chromatog.* **454**, 121-128.
32. Ligocki M. P. and Pankow J. F. (1989) Measurements of the gas/particle distributions of atmospheric organic compounds. *Environ. Sci. Technol.* **23**, 75-83.
33. Loiselle S. A., Hodgson A. T. and Offermann F. J. (1991) An indoor sampler for polycyclic aromatic compounds. *Indoor Air* **2**, 191-210.
34. Mahanama K. R. R., Gundel L. A. and Daisey J. M. (1994) Selective fluorescence detection of polycyclic aromatic hydrocarbons in environmental tobacco smoke and other airborne particles. *Intern. J. Environ. Anal. Chem.*
35. McDow S. R. and Huntzicker J. J. (1990) Vapor adsorption artifact in the sampling of organic aerosol: face velocity effects. *Atmos. Environ.* **24A**, 2563-2571.
36. Miguel A. H. and De Andrade J. B. (1986) Desorptivity versus chemical reactivity of polycyclic aromatic hydrocarbons (PAHs) in atmospheric aerosols collected on quartz fiber filters. *Intern. J. Environ. Anal. Chem.* **26**, 265-278.
37. National Research Council (1986) Exposure-dose relationships for environmental tobacco smoke. In *Environmental Tobacco Smoke: Measuring Exposures and Assessing Health Effects* (edited by Committee on Passive Smoking), pp. 120-132. National Academy Press, Washington.
38. Noll K. E. and Sarlis J. N. (1988) Adsorption characteristics of activated carbon and XAD-4 for the removal of hazardous organic solvents. *J. Air Poll. Control Assoc.* **38**, 1512-1517.
39. Offermann F. J., Loiselle S. A., Daisey J. M., Hodgson A. T. and Gundel L. A. (1990) Sampling, analysis and data validation of indoor concentrations of polycyclic aromatic hydrocarbons.
40. Offermann F. J., Loiselle S. A., Hodgson A. T., Gundel L. A. and Daisey J. M. (1991) A pilot study to measure indoor concentrations and emission rates of polycyclic aromatic hydrocarbons. *Indoor Air* **1**, 497-512.
41. Pankow J. F. (1987) Review and comparative analysis of the theories on partitioning between the gas and aerosol particulate phases in the atmosphere. *Atmos. Environ.* **21**, 2275-2283.

42. Pankow J. F. (1992) Application of common y-intercept regression parameters for log Kp vs 1/T for predicting gas-particle partitioning in the urban environment. *Atmos. Environ.* **26A**, 2489-2497.
43. Pankow J. F., Isabelle L. M., Buchholz D. A., Luo W. and Reeves B. D. (1994) Gas/particle partitioning of polycyclic aromatic hydrocarbons and alkanes to environmental tobacco smoke. *Environ. Sci. Technol.* **28**, 363-365.
44. Possanzini M., Febo A. and Liberti A. (1983) New design of a high-performance denuder for the sampling of atmospheric pollutants. *Atmos. Environ.* **17**, 2605-2610.
45. Pupp C., Lao R. C., Murray J. J. and Pottie R. F (1974) Equilibrium vapour concentrations of some polycyclic aromatic hydrocarbons, As4O6 and SeO2 and the collection efficiencies of these air pollutants. *Atmos. Environ.* **8**, 915-925.
46. Rohm and Haas Co. (1993) Amberlite XAD-4 Polymeric Adsorbent. Technical Bulletin 1E403, Rohm and Haas Co., Spring House, PA 19477.
47. Salomaa S., Tuominen J. and Skyttä (1988) Genotoxicity and PAC analysis of particulate and vapour phases of environmental tobacco smoke. *Mutat. Res.* **204**, 173-183.
48. Schomburg C. J., Glotfelty D. E. and Seiber J. N. (1991) Pesticide occurrence and distribution in fog collected near Monterey, California. *Environ. Sci. Technol.* **25**, 155-160.
49. Seiber J. N., Glotfelty D. E., Lucas A. D., McChesney M. M., Sagebiel J. C. and Wehner T. A. (1990) A multiresidue method by high performance liquid chromatography-based fractionation and gas chromatographic determination of trace levels of pesticides in air and water. *Arch. Environ. Contam. Toxicol.* **19**, 583-592.
50. Sonnefeld W. J., Zoller W. H. and May W. E. (1983) Dynamic coupled-column liquid chromatographic determination of ambient temperature vapor pressures of polynuclear aromatic hydrocarbons. *Anal. Chem.* **55**, 275-280.
51. Stevens R. K., Dzubay T. G., Shaw R. W. Jr., McClenny W. A., Lewis C. W. and Wilson W. E. (1980) Characterization of the aerosol in the Great Smoky Mountains. *Environ. Sci. Technol.* **14**, 1491-1498.
52. Storey J. M. E. and Pankow J. F. (1992) Gas-particle partitioning of semi-volatile organic compounds to model atmospheric particulate materials - I. sorption to graphite, sodium chloride, alumina, and silica particles under low humidity conditions. *Atmos. Environ.* **26A**, 435-443.
53. Turpin B. J., Liu S.-P., Podolske K. S., Gomes M. S. P., Eisenreich S. J. and McMurry P. H. (1993) Design and evaluation of a novel diffusion separator for measuring gas/particle distributions of semivolatile organic compounds. *Environ. Sci. Technol.* **27**, 2441-2449.

54. Van Vaeck L., Van Cauwenberghe K. and Janssens J. (1984) The gas-particle distribution of organic aerosol constituents: Measurements of the volatilisation artefact in hi-vol cascade impactor sampling. *Atmos. Environ.* **18**, 417-430.
55. Vossler T. L., Stevens R. K., Paur R. K., Baumgardner R. E. and Bell J. P. (1988) Evaluation of improved inlets and annular denuder systems to measure inorganic air pollutants. *Atmos. Environ.* **22**, 1729-1736.
56. Wagel D. J., Tierman T. O., Taylor M. L., Garrett J. H., VanNess G. F., Solch J. G. and Harden L. A. (1989) Assessments of air sampling techniques for collecting airborne polyhalogenated dibenzo-p-dioxins (PCDD), dibenzofurans (PCDF) and biphenyls (PCB). *Chemosphere* **18**, 177-184.
57. Wilson E. B. (1952) *An Introduction to Scientific Research*. McGraw-Hill, New York, 244.
58. Wong J. M., Kado N. Y., Kuzmicky P. A., Ning H. S., Woodrow J. E., Hsieh D. P. H. and Seiber J. N. (1991) Determination of volatile and semivolatile mutagens in air using solid adsorbents and supercritical fluid extraction. *Anal. Chem.* **63**, 1644-1650.
59. Yamasaki H., Kuwata K. and Miyamoto H. (1982) Effects of ambient temperature on aspects of airborne polycyclic aromatic hydrocarbons. *Environ. Sci. Technol.* **16**, 189-194.
60. Ye Y., Tsai C.-J., Pui D. Y. H. and Lewis C. W. (1991) Particle transmission characteristics of an annular denuder ambient sampling system. *Aerosol Sci. Technol.* **14**, 102-111.

TABLES

Table 1. Detection and quantitation limits for gas and particulate semi-volatile polycyclic aromatic hydrocarbons (PAH).

Table 2. Percent recovery of PAH on the first of three denuders in series, versus flow rate and sampling time.

Table 3. Reproducibility data for PAH in simulated environmental tobacco smoke.

Table 4. Comparison of IOVPS to a sorbent bed sampler for collection of gas phase PAH.

Table 5. Phase distributions of polycyclic aromatic hydrocarbons in indoor laboratory room air for two sampling techniques.

Table 6. Concentration ranges for gas phase PAH in ng m^{-3} .

Table 7. Phase distributions of polycyclic aromatic hydrocarbons in simulated environmental tobacco smoke.

FIGURE CAPTIONS

- Figure 1. Sampling configurations for the integrated organic/particle sampler (IOVPS). The arrows show the direction of airflow. d1, d2 and d3 indicate XAD-4-coated glass annular denuder sections that were connected by threaded couplers. The filter pack contained one or two filters. The left side of the figure shows the configuration used for initial testing and validation studies in combustion-free indoor air. The right side shows the configuration used for sampling simulated environmental tobacco smoke in an environmental chamber.
- Figure 2. Cross sectional diagram of a coated annular denuder. The critical dimensions are indicated.
- Figure 3. Scanning electron photomicrographs of (top) an uncoated sandblasted glass annular denuder fragment; (bottom) an annular denuder fragment coated with ground XAD-4 adsorbent resin. The instrument was used at 20 keV, 50 microA beam, 26o tilt and 12-mm working distance.
- Figure 4. Semi-logarithmic plots of the ratio of the outlet concentration C_{out} to the inlet concentration C_{in} for several gas-phase PAH concentrations versus the ratio of denuder length to the volume of sampled air. The line shows 90% reduction of the inlet concentration for the each denuder section. (a) Naphthalene; (b) 1-Methylnaphthalene; (c) Fluorene; and (d) Phenanthrene. Closed symbols show data for one denuder section; open symbols correspond to two sections. Sampling conditions are indicated as $\blacktriangledown = 5 \text{ L min}^{-1}$, 3 hours; $\blacktriangle = 5 \text{ L min}^{-1}$, 6 hours; $\blacksquare = 10 \text{ L min}^{-1}$, 3 hours; $\blacklozenge = 10 \text{ L min}^{-1}$, 6 hours, $\blacklozenge = 20 \text{ L min}^{-1}$, 3 hours; $\blacklozenge = 20 \text{ L min}^{-1}$, 6 hours. For naphthalene and 1-methylnaphthalene sampled at 20 L min^{-1} , C_{in} was taken from the filter-sorbent bed sampler data.

Table 1. Detection and quantitation limits for semi-volatile PAH^{a,b}

Gas phase	LLD ^a ng	LLQ ^b ng	LLD ^{a,c} ng m ⁻³	LLQ ^{b,c} ng m ⁻³
PAH				
Naphthalene	13	44	43	130
1- Methyl-naphthalene	4.8	16	16	48
2- Methyl-naphthalene	19	62	63	190
Biphenyl	31	105	105	315
Acenaphthene and acenaphthylene	1.6	5.5	5.3	16
Fluorene	2.9	9.7	9.7	29
Phenanthrene	6.4	21	21	64
Anthracene	0.06	0.19	0.2	0.6
Fluoranthene	0.5	1.7	1.7	5.0
Pyrene	0.5	1.7	1.7	5.0
Benz(a)anthracene	0.03	0.1	0.1	0.3
Chrysene	0.22	0.7	0.7	2.2
Particulate phase				
Particulate phase	LLD ^a ng	LLQ ^b ng	LLD ^{a,c} ng m ⁻³	LLQ ^{b,c} ng m ⁻³
PAH				
Naphthalene	5.2	18	17	52
1- Methyl-naphthalene	3.5	12	12	35
2- Methyl-naphthalene	3.1	10	10	31
Biphenyl	0.74	2.2	2.5	7.4
Acenaphthene and acenaphthylene	0.42	1.4	1.4	4.2
Fluorene	0.37	1.2	1.2	3.7
Phenanthrene	1.6	5.2	5.2	16
Anthracene	0.04	0.1	0.1	0.4
Fluoranthene	1.3	4.5	4.5	13
Pyrene	0.42	1.4	1.4	4.2
Benz(a)anthracene	0.015	0.05	0.1	0.2
Chrysene	0.32	1.1	1.1	3.2

^a The lower limit of detection (LLD) is estimated as 3 times the standard deviation observed for the blanks.

^b The lower limit of quantitation (LLQ) is estimated as 10 times the standard deviation observed for the blanks.

^c LLD and LLQ for 0.3 m³ air sample (1 hour sampling at 5 L min⁻¹).

Table 2. Percent recovery of PAH on the first three denuders in series flow rate and sampling duration.^a

<i>Naphthalenes</i> ^b			
Sampling time hours	Flow rate, L min ⁻¹		
	5	10	20
3	99	93	33
6	93	88	32

<i>Fluorene</i>			
Sampling time hours	Flow rate, L min ⁻¹		
	5	10	20
3	100	96	75
6	93	78	71

<i>Phenanthrene</i>			
Sampling time hours	Flow rate, L min ⁻¹		
	5	10	20
3	100	97	81
6	89	91	77

^a Based on sampling indoor laboratory room air. Total gas-phase PAH concentration was the sum of concentrations on three denuders in series. Observed concentration ranges are given in Table 5.

^b Average values for naphthalene, 1-methylnaphthalene and 2-methylnaphthalene. Total gas phase concentrations for 20 L min⁻¹ were based on values from sorbent bed sampler (for the naphthalenes only).

Table 3. Reproducibility of PAH concentration measurements in simulated environmental tobacco smoke.

PAH	<i>Gas phase</i>			<i>Particle Phase</i>		
	Mean ng m ⁻³	Difference ng m ⁻³	CV ^a %	Mean ng m ⁻³	Difference ng m ⁻³	CV %
Naphthalene	822	115	12	bd ^b	-	-
1- Methyl-naphthalene	334	26	7	bd	-	-
2- Methyl-naphthalene	526	56	9	bd	-	-
Biphenyl	45	14	27	bd	-	-
Acenaphthene and acenaphthylene	72	17	21	bd	-	-
Fluorene	56.5	5.0	8	bd	-	-
Phenanthrene	43.1	13.0	15	bd	-	-
Anthracene	3.85	0.76	17	bd	-	-
Fluoranthene	3.73	0.75	18	2.3	0.10	4
Pyrene	13.8	6.0	39	3.0	0.5	14
Benz(a)anthracene	0.15	0.04	24	11.1	0.6	4
Chrysene	0.86	0.10	10	30.1	5.0	15
		Average	17		Average	9
		Std Dev	9		Std Dev	6

^a CV = coefficient of variation = σ/mean ; σ was estimated from the difference as suggested by Wilson (1952).

^b Below the limit of detection.

Table 4. Comparison of IOVPS to filter-sorbent bed sampler for collection of gas-phase PAH in indoor air at two flow rates.^a

PAH	Flow rate	Denuder/Sorbent	Denuder/Sorbent
		ratio 10 L min ⁻¹	ratio 20 L min ⁻¹
Naphthalene		0.83	0.68
1- Methyl-naphthalene		1.11	0.80
2- Methyl-naphthalene		1.03	0.70
Biphenyl		1.03	0.60
Acenaphthene and acenaphthylene		0.87	0.72
Fluorene		0.95	0.85
Phenanthrene		1.18	0.94
Anthracene		0.94	0.95
Fluoranthene		1.00	0.84
Pyrene		1.05	0.84
Chrysene		bd ^b	0.65
Average		1.00	0.78
Standard deviation		0.10	0.12

^a Three-hour sampling periods on two different days.

^b Below the detection limit.

Table 5. Phase distributions of polycyclic aromatic hydrocarbons in indoor laboratory room air at 21°C.

PAH	IOVPS (g) ng m ⁻³	IOVPS (p) ng m ⁻³	IOVPS p (g+p) ⁻¹	Filt-Sorb (g) ng m ⁻³	Filt-Sorb (p) ng m ⁻³	Filt-Sorb p (g+p) ⁻¹
Phenanthrene	39.1	3.43	0.08	41.5	1.42	0.03
Pyrene	2.42	0.44	0.15	2.88	0.17	0.06
Chrysene	2.12	0.55	0.21	3.34	0.60	0.15

Table 6. Concentration ranges for gas phase PAH in ng m⁻³

PAH	<i>Indoor air</i>			<i>Environmental Tobacco Smoke</i>		
	Minimum	Maximum	Average	Minimum	Maximum	Average
Naphthalene	162	545	338	784	1690	1099
1- Methyl-naphthalene	43	161	89	334	748	485
2- Methyl-naphthalene	67	220	142	526	931	719
Biphenyl	4.1	62	25	45	423	189
Acenaphthene and acenaphthylene	3.3	18	8.3	2.7	134	70
Fluorene	4.1	17	8.2	57	267	129
Phenanthrene	18	38	23	43	151	99
Anthracene	0.1	0.6	0.4	3.9	22	13
Fluoranthene	3.5	9.8	6.5	3.7	13	10
Pyrene	2.2	4.6	3.0	14	64	44
Benz(a)anthracene	0.1	0.7	0.4	0.2	1.1	0.4
Chrysene	0.8	2.0	1.4	0.9	10	5.8

Table 7. Phase distributions of polycyclic aromatic hydrocarbons in environmental tobacco smoke.^a

PAH	gas ng m ⁻³	particles ng m	fraction in particles
Naphthalene	822	<17	<0.02
1-Methyl-naphthalene	334	<12	<0.04
2-Methyl-naphthalene	526	<10	<0.02
Acenaphthene and acenaphthylene	72.2	<1.4	<0.02
Fluorene	56.5	<1.7	<0.02
Phenanthrene	43.1	<5.2	<0.11
Anthracene	3.85	<0.1	<0.03
Fluoranthene	3.73	2.3	0.38
Pyrene	13.8	3	0.18
Benz(a)anthracene	0.15	10.4	0.99
Chrysene	0.86	30.1	0.97

^a Sampled at 5 L min⁻¹ for 1 hour.

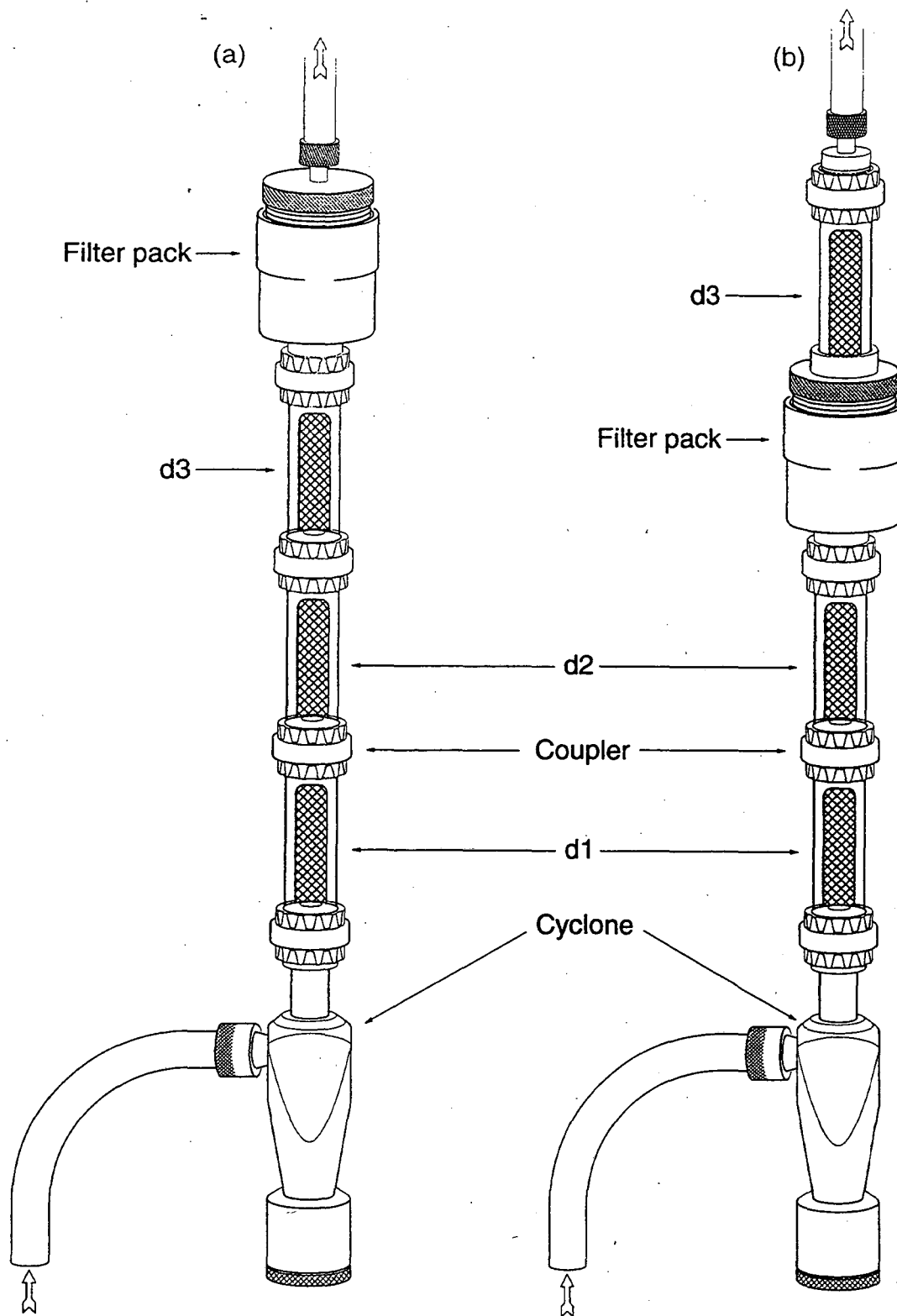

Figure 1. Sampling configurations for the integrated organic/particle sampler (IOVPS). The arrows show the direction of airflow. d1, d2 and d3 indicate XAD-4-coated glass annular denuder sections that were connected by threaded couplers. The filter pack contained one or two filters. The left side of the figure shows the configuration used for initial testing and validation studies in combustion-free indoor air. The right side shows the configuration used for sampling simulated environmental tobacco smoke in an environmental chamber.

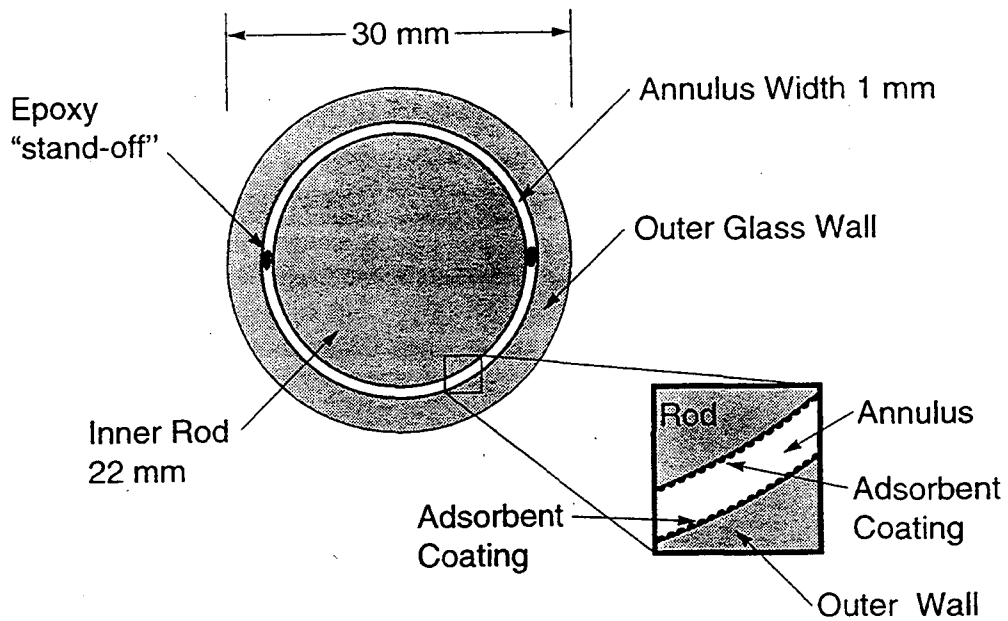

Figure 2. Cross sectional diagram of a coated annular denuder. The critical dimensions are indicated.

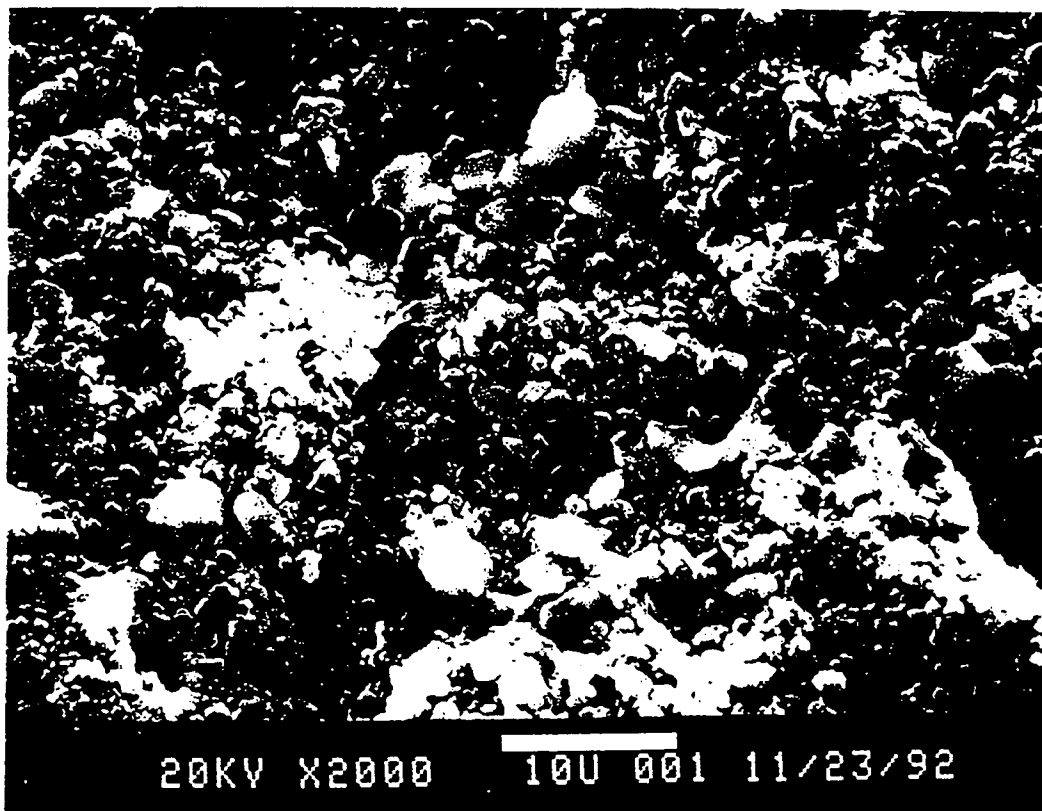
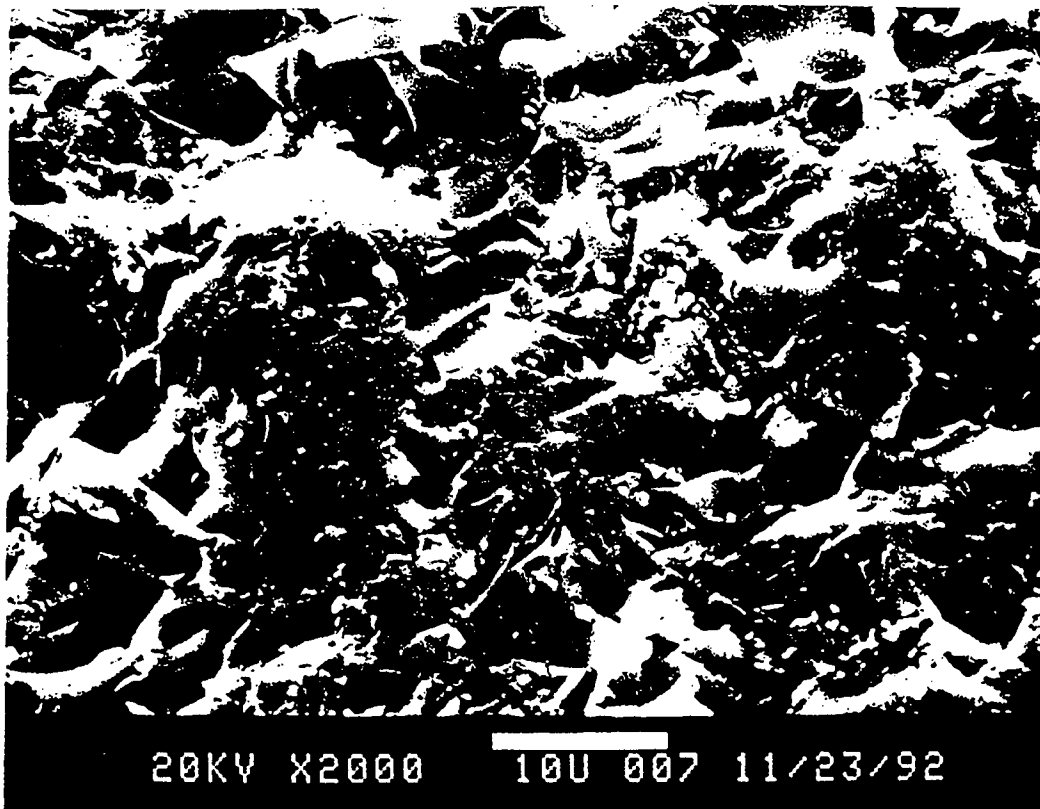

Figure 3. Scanning electron photomicrographs of (top) an uncoated sandblasted glass annular denuder fragment; (bottom) an annular denuder fragment coated with ground XAD-4 adsorbent resin. The instrument was used at 20 keV, 50 microA beam, 26° tilt and 12-mm working distance.

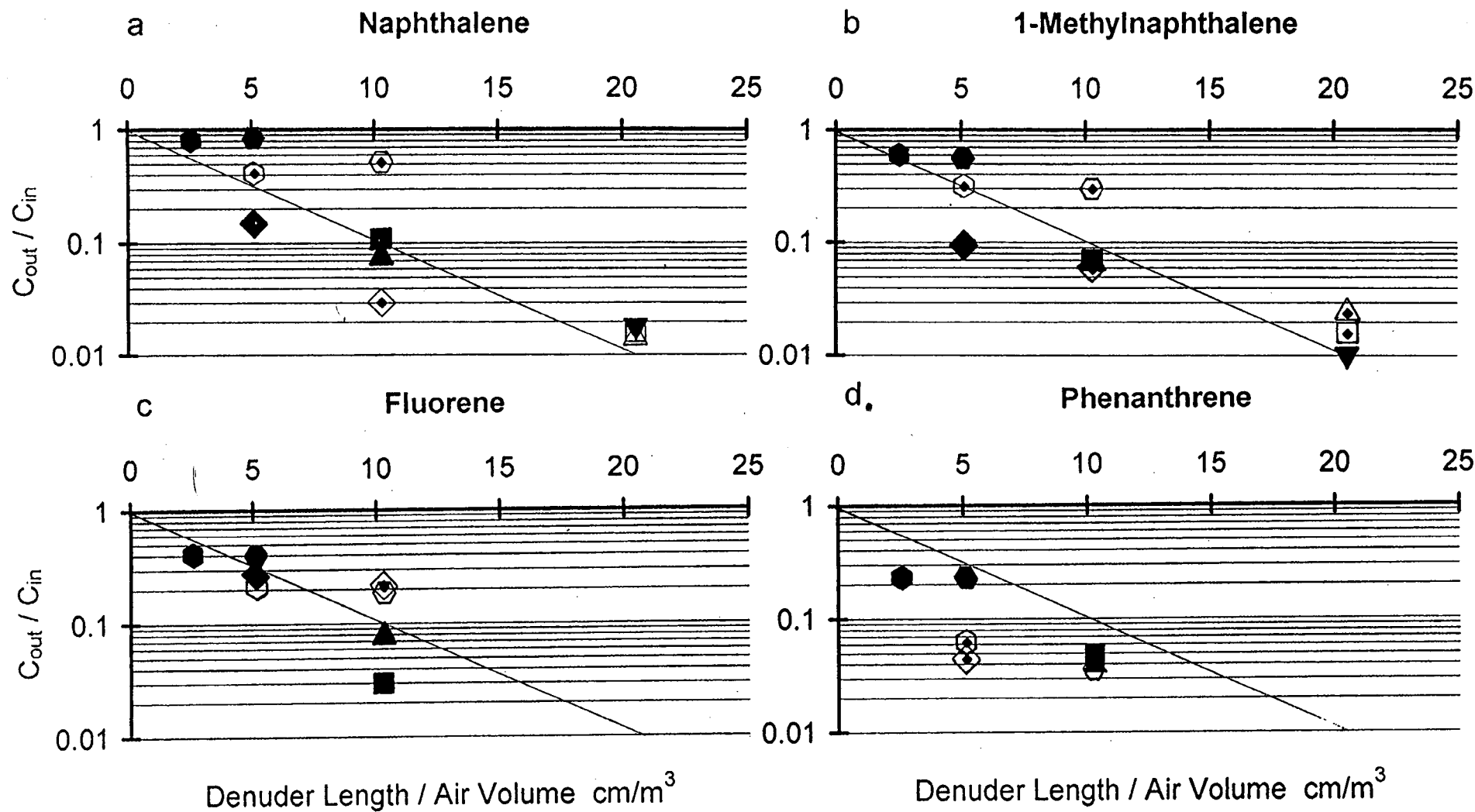

Figure 4. Semi-logarithmic plots of the ratio of the outlet concentration C_{out} to the inlet concentration C_{in} for several gas-phase PAH concentrations versus the ratio of denuder length to the volume of sampled air. The line shows 90% reduction of the inlet concentration for the each denuder section. (a) Naphthalene; (b) 1-Methylnaphthalene; (c) Fluorene; and (d) Phenanthrene. Closed symbols show data for one denuder section; open symbols correspond to two sections. Sampling conditions are indicated as \blacktriangledown = 5 L min⁻¹, 3 hours; \blacktriangle = 5 L min⁻¹, 6 hours; \blacksquare = 10 L min⁻¹, 3 hours; \blacklozenge = 10 L min⁻¹, 6 hours; \circ = 20 L min⁻¹, 3 hours; \diamond = 20 L min⁻¹, 6 hours. For naphthalene and 1-methylnaphthalene sampled at 20 L min⁻¹, C_{in} was taken from the filter-sorbent bed sampler data.

LAWRENCE BERKELEY LABORATORY
UNIVERSITY OF CALIFORNIA
TECHNICAL INFORMATION DEPARTMENT
BERKELEY, CALIFORNIA 94720