

# Lawrence Berkeley National Laboratory

## Recent Work

### Title

THE DEPENDENCE OF THE 33 MeV  $n+$  PRODUCTION CROSS SECTION ON ATOMIC NUMBER

### Permalink

<https://escholarship.org/uc/item/6ss9b0t1>

### Authors

Sagane, Ryokichi  
Dudziak, Walter.

### Publication Date

1953-07-22

311

UCRL 2284

**UNCLASSIFIED**

UNIVERSITY OF  
CALIFORNIA

*Radiation  
Laboratory*

TWO-WEEK LOAN COPY

*This is a Library Circulating Copy  
which may be borrowed for two weeks.  
For a personal retention copy, call  
Tech. Info. Division, Ext. 5545*

BERKELEY, CALIFORNIA

## DISCLAIMER

This document was prepared as an account of work sponsored by the United States Government. While this document is believed to contain correct information, neither the United States Government nor any agency thereof, nor the Regents of the University of California, nor any of their employees, makes any warranty, express or implied, or assumes any legal responsibility for the accuracy, completeness, or usefulness of any information, apparatus, product, or process disclosed, or represents that its use would not infringe privately owned rights. Reference herein to any specific commercial product, process, or service by its trade name, trademark, manufacturer, or otherwise, does not necessarily constitute or imply its endorsement, recommendation, or favoring by the United States Government or any agency thereof, or the Regents of the University of California. The views and opinions of authors expressed herein do not necessarily state or reflect those of the United States Government or any agency thereof or the Regents of the University of California.

UCRL-2284  
Unclassified-Physics Distribution

**UNCLASSIFIED**

UNIVERSITY OF CALIFORNIA  
Radiation Laboratory  
Contract No. W-7405-eng-48

THE DEPENDENCE OF THE 33 MEV  $\pi^+$  PRODUCTION  
CROSS SECTION ON ATOMIC NUMBER

Ryokichi Sagane and Walter Dudziak

July 22, 1953

Berkeley, California

THE DEPENDENCE OF THE 33 MEV  $\pi^+$  PRODUCTION  
CROSS SECTION ON ATOMIC NUMBER

Ryokichi Sagane and Walter Dudziak

Radiation Laboratory, Department of Physics  
University of California, Berkeley, California

July 22, 1953

A preliminary result has been obtained on the variation of the ( $T_{\pi} = 33$  Mev) positive pion production cross section with atomic number which results from the interaction of a ( $T_p = 340$  Mev) proton beam with target nuclei. The chief concern is the functional behavior with atomic number of pion production cross sections at different pion energies.

For this experiment the targets consisted of six elements (Be, C, Al, Cu, Ag and Pb). These targets were in tubular form having the following dimensions:

- (a) for the light elements (Be, C, Al) 3/4 in. O. D. ,  
1/2 in. I. D. and 1-1/2 in. long
- (b) for the heavy elements (Cu, Ag, Pb) 3/4 in. O. D. ,  
1/2 in. I. D. and 1/2 in. long.

A 1/2 in. long tubular carbon target was used to determine the normalization factor necessary for the difference in target geometry between the light and heavy elements.

The targets were mounted on the axis of a 22 in. (pole-diameter) spiral orbit spectrometer. They were bombarded by a (1 in. diameter) collimated proton beam which was electrically deflected out from the 184-inch synchro-cyclotron, integrated by an argon filled ion chamber, and then passed through the (1-1/2 in. I. D.) axial hole of the magnet.

The principle of "the spiral-orbit spectrometer"<sup>1</sup> was used to focus pions of known energy which were emitted at  $90^\circ$  to the incoming proton beam. The pions were detected by means of C-2 Ilford (200  $\mu$ ) nuclear emulsions which were placed in the region of the "stable orbit" as is shown schematically in

Fig. 1. Since pions of  $T_{\pi} = 9.2$  Mev were being focussed at the "stable orbit" a 4 in. O.D. tubular copper degrader of appropriate thickness permitted the selection of the  $T_{\pi} = 33 \pm 3$  Mev pions created in the target.

The same volume of emulsion was scanned for each of the seven exposures. The relative  $\pi^{+}$  production cross section per target nucleus was determined and is presented in Fig. 2. The uncertainties indicated in the spectral data are statistical probable errors involved in the counting of pions. Shown also in Fig. 2 are

- (a)  $Z^1$  variation normalized at the Ag point
- (b)  $Z^{2/3}$  variation normalized at the Ag point
- (c)  $Z^{2/3}$  variation normalized at the Al point.

The experimental results for the six elements indicate clearly a better fit to a  $Z^{2/3}$  variation. This is quite similar to the results obtained by one of the authors for  $T_{\pi} = 42$  Mev pions.<sup>2</sup> Furthermore the data are in accord with those reported by Hamlin, et al.<sup>3</sup>

Exposures have also been obtained (for  $T_{\pi} = 25$  Mev and  $T_{\pi} = 11$  Mev) for negative and positive pions. These results will soon be reported.

#### ACKNOWLEDGMENTS

We are grateful to Professors E. Lawrence, R. Thornton, W. Barkas and C. Richman for their aid in obtaining the funds for the spiral-orbit spectrometer as well as their continued interest. We would like to acknowledge the cooperation of Jimmy Vale and the cyclotron crew in making the exposures.

REFERENCES

1. G. Miyamoto, Proc. Phys. Math. Soc. (Japan) 17, 587 (1943).  
R. Sagane and W. Gardner, UCRL Translation III (1951).  
R. Sagane, UCRL-2161 (1953).
2. R. Sagane, Phys. Rev. 90, 1003 (1953).  
R. Sagane, UCRL-2161 (1953).
3. D. Hamlin, M. Jakobson, J. Merritt and A. Schultz, Phys. Rev. 84,  
857 (1951).

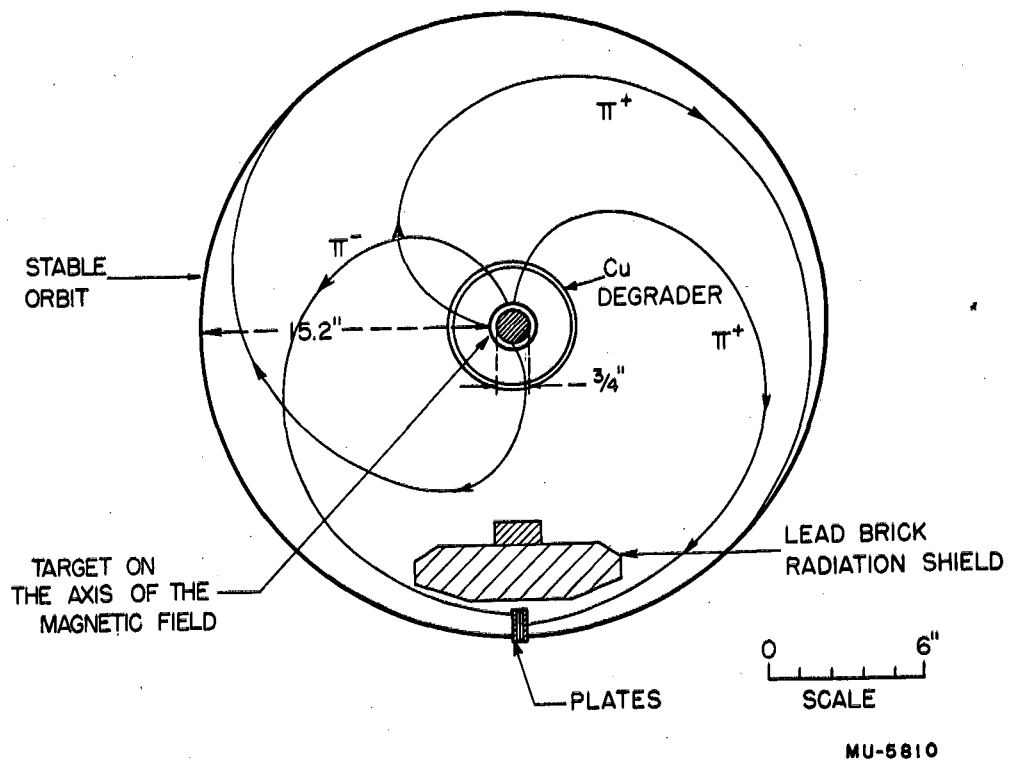

**Fig. 1** Schematic diagram of experimental arrangement illustrating the charged pion trajectories in the median plane of the spiral orbit spectrometer.



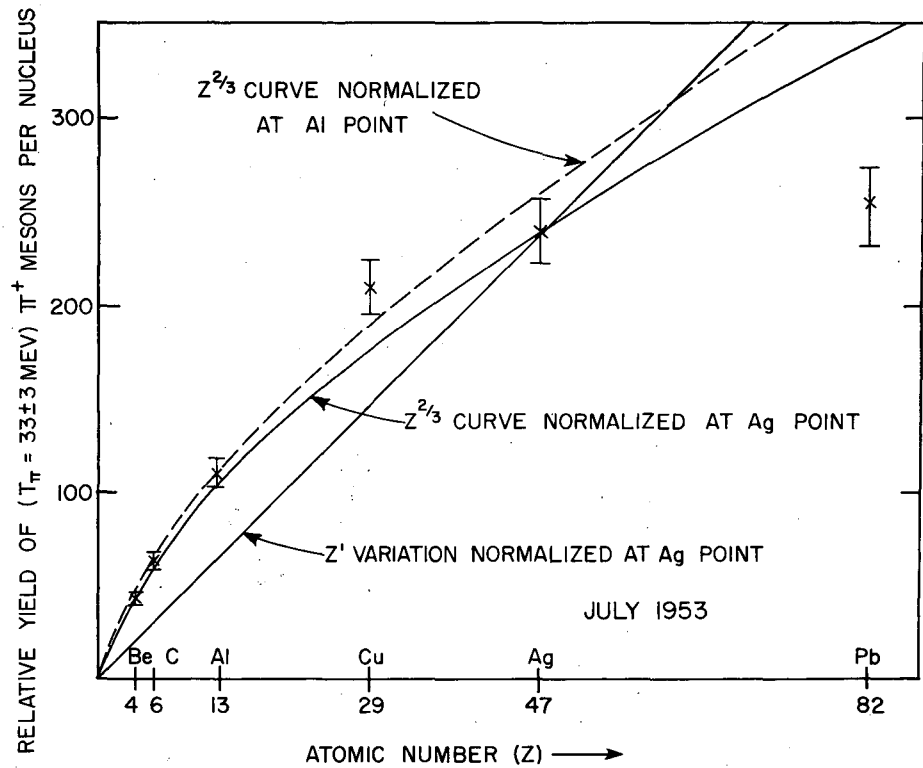

MU-5811

Fig. 2 Relative ( $T_{\pi} = 33 \pm 3 \text{ Mev}$ )  $\pi^+$  production cross sections as a function of atomic number illustrating the variation of experimental data from a  $Z^1$  and  $Z^{2/3}$  dependence.