

UC Berkeley

Fisher Center Working Papers

Title

Assessing the Impacts of Residential Growth Caps-- The San Diego Experience

Permalink

<https://escholarship.org/uc/item/6wg532c7>

Authors

Kroll, Cynthia A.
Landis, John D.
Griesenbeck, Bruce
et al.

Publication Date

1988-10-01

Peer reviewed



Institute of
Business and
Economic Research

University of
California,
Berkeley

**CENTER FOR REAL ESTATE
AND URBAN ECONOMICS
WORKING PAPER SERIES**

WORKING PAPER NO. 88-149

ASSESSING THE IMPACTS OF RESIDENTIAL
GROWTH CAPS - THE SAN DIEGO EXPERIENCE

BY

CYNTHIA A. KROLL

JOHN D. LANDIS

BRUCE GRIESENBECK

TIMOTHY STROSHANE

DENA BELZER

**These papers are preliminary
in nature: their purpose is
to stimulate discussion and
comment. Therefore, they
are not to be cited or quoted
in any publication without
the express permission of
the author.**

GRADUATE SCHOOL OF BUSINESS ADMINISTRATION

**CENTER FOR REAL ESTATE AND URBAN ECONOMICS
UNIVERSITY OF CALIFORNIA AT BERKELEY**

The Center was established in 1950 to examine in depth a series of major changes and issues involving urban land and real estate markets. The Center is supported by both private contributions from industry sources and by appropriations allocated from the Real Estate Education and Research Fund of the State of California.

INSTITUTE OF BUSINESS AND ECONOMIC RESEARCH

The Institute of Business and Economic Research is a department of the University of California with offices on the Berkeley campus. It exists for the purpose of stimulating and facilitating research into problems of economics and of business with emphasis on problems of particular importance to California and the Pacific Coast, but not to the exclusion of problems of wider import.

ASSESSING THE IMPACTS OF RESIDENTIAL GROWTH CAPS--
THE SAN DIEGO EXPERIENCE

by

Cynthia A. Kroll
John D. Landis
Bruce Griesenbeck
Timothy Strohane
Dena Belzer

Center for Real Estate and Urban Economics
University of California, Berkeley

WORKING PAPER NO. 88-149

October 1988

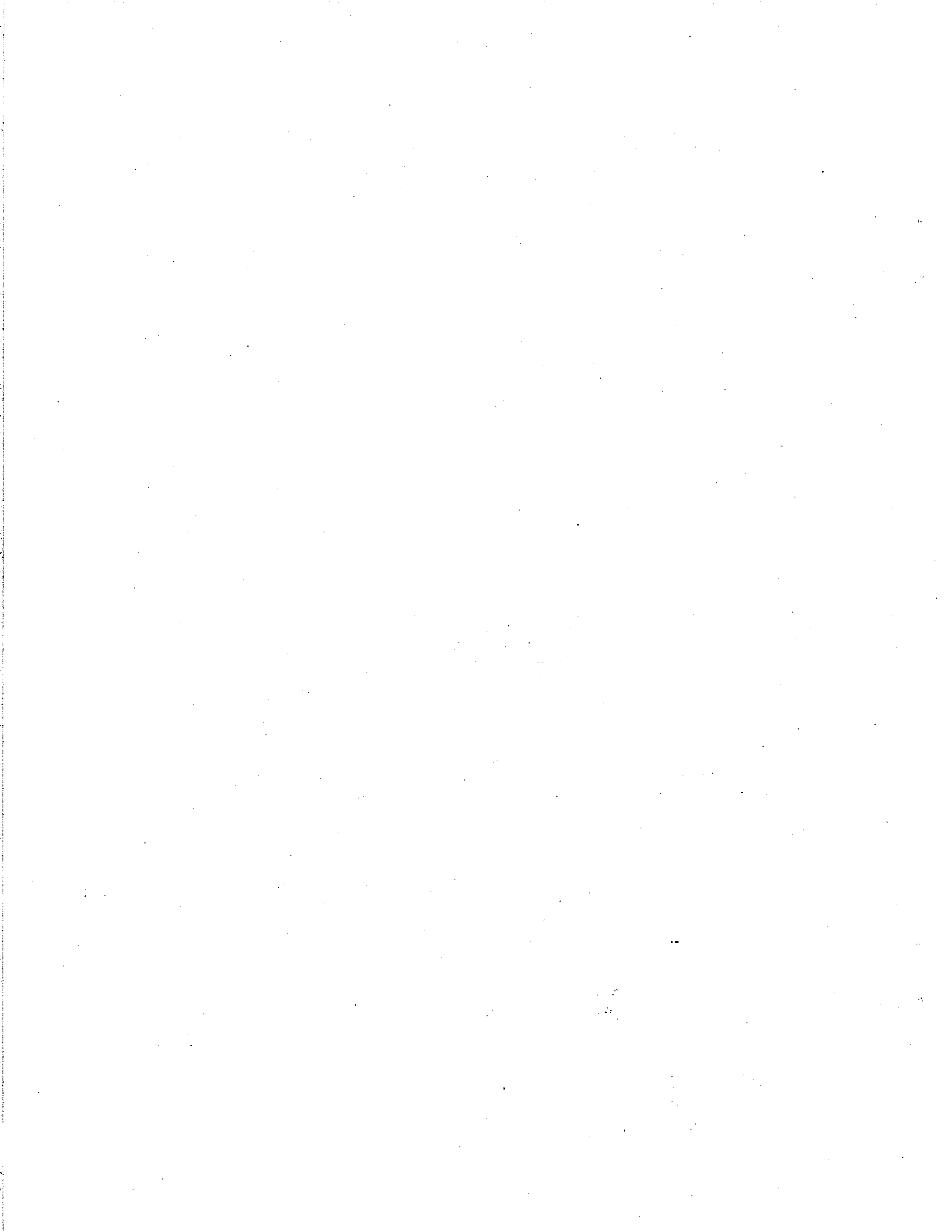

ASSESSING THE IMPACTS OF RESIDENTIAL GROWTH CAPS--THE SAN DIEGO EXPERIENCE

**by Cynthia A. Kroll, John D. Landis, Bruce Griesenbeck,
Timothy Stroshane and Dena Belzer**

**Center for Real Estate and Urban Economics
University of California at Berkeley**

ABSTRACT

In 1987, the City of San Diego became the largest city in the United States to enact a residential building permit cap. While the initial cap was for an 18 month period only, it appears likely that some level of building cap will be adopted for at least a 5 year period by the end of 1988. The possibility that housing production in the city may be reduced in the future has raised concerns over the impacts of such reductions on the housing market and the broader economy.

This paper reports an analysis performed for the City of San Diego on the effects of a citywide residential building cap on the housing market and economy of San Diego County. Time-series econometric models are used to identify the key external factors driving the basic sectors of the San Diego economy and the key internal factors driving other employment sectors in the economy. Interactions between economic growth, housing production, housing prices, income and population growth are also identified. Growth of the San Diego economy is forecast through 1995 with and without building activity restrictions, giving estimates of employment, population, housing production and housing price levels. The effects on these factors of alternative caps are evaluated.

The analysis finds that the countywide impacts of a housing cap enacted in the City of San Diego would be moderated by the size of the existing housing base and economy and by expected construction activity elsewhere in the county. A housing cap of 4,500 in the City of San Diego is likely to reduce population and employment levels by less than 1 percent in 1995, while increasing countywide housing prices by about 2 percent and decreasing real per capita income levels by a similar amount. When the distribution of these impacts is considered, however, the housing price effects are substantially higher within the City of San Diego, especially where building activity is most curtailed, and the income effects are likely to be concentrated on a small segment of the population. Because housing and employment levels will not be significantly reduced, caps appear to have no effect on the concerns addressed in growth control initiatives. Thus, the measures will have significant housing and income impacts on some segments of the population without resolving the county's very serious problems of traffic congestion and infrastructure constraints.

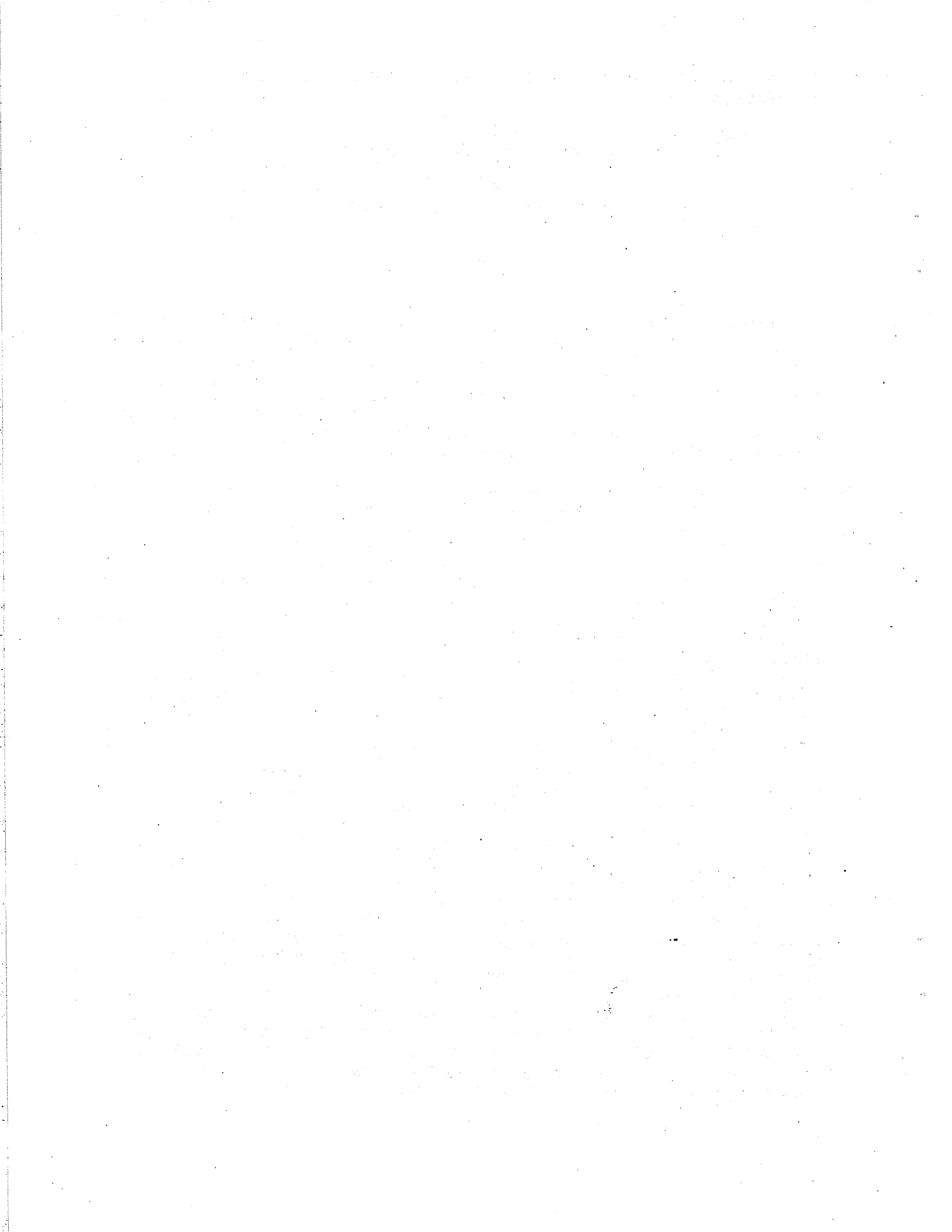

ASSESSING THE IMPACTS OF RESIDENTIAL GROWTH CAPS--THE SAN DIEGO EXPERIENCE

I. Introduction

With strong economic growth and a healthy housing market, California has experienced an intensification of growth management activity since the mid 1980s. Local residents, using the initiative process, and local government officials are grappling with the concerns that arise with rapid growth--traffic congestion, the changing visual character of the environment, and infrastructure inadequacies. The latest wave of California growth controls has emerged particularly strongly in Southern California. Once seen by builders and envious Northern California business officials as highly accommodating to growth, Southern California counties and cities have demonstrated a sharp reversal in attitudes towards growth over the past few years. Residential growth controls have become widespread, enacted in small towns and the largest cities, while a smaller but significant number of nonresidential growth control measures have also been enacted (Kroll and Griesenbeck 1987).

The City of San Diego has the distinction of being the largest city, both in Southern California and in the United States, to enact a residential growth cap. A temporary residential building permit cap was adopted in mid-1987, and at the time of the research reported here, various alternative cap levels were under consideration for the November 1988 ballot (Citizens for Limited Growth 1988, Growth Management Element 1988).

Measures of this type raise a number of critical issues for

planners and business leaders concerned with housing, land use patterns and economic growth in California. First, how do caps on residential construction activity affect housing supply, sales prices and rents? Second, how is employment growth affected by caps, both through the curtailment of construction jobs and through the response of other sectors to the added costs of doing business in the region? Third, what are the effects of caps on the geographic distribution of the population and on the relative prices faced by different groups in the population? Finally, to what extent do growth control measures such as residential caps address the problems towards which they are directed? How effective is a limitation on building activity in slowing the growth of traffic or protecting sensitive environmental areas?

The research effort described in this paper involved the development of a regional model to assess the impacts of a policy of residential building caps in the City of San Diego on the economy, housing market and rate of growth of the city and San Diego County. The results of the modeling effort contribute to an understanding of the likely effectiveness of different types of growth measures in resolving the problems concerning local residents.

The paper begins with a short summary of related theoretical and empirical work. A description of recent growth management history in San Diego is next, followed by a brief discussion of methodological issues and the structuring of the model. Discussion of the model results focuses on our analysis of the structure of the regional economy, linkages between the economy

and building activity, and the forecasting of future growth and housing prices in the region with and without growth. We also address concerns around the reliability of the findings.

Finally, we outline the implications of the results for growth control policy in the City of San Diego and more generally for the use of land use policy as a means of limiting or encouraging growth.

II. Research on the Impacts of Growth Management

The economic theory of the impacts of growth management on housing prices is quite straightforward. Restrictions on expansion of the housing stock, through such measures as moratoria or annual caps on building permits, will reduce the rate of growth of the overall supply of housing and thus increase housing prices from the levels they would otherwise reach (Lillydahl and Singell 1987). Higher home prices will affect the rate of homeownership and may possibly slow the rate of population growth either through delaying family formation among existing residents or through reducing the level of in-migration to the community. If the size of the labor market is affected or the cost of labor (because of housing related cost of living increases), this will affect employment growth (Rubinfeld 1978).

On the nonresidential side, caps on retail, office or industrial space will reduce the growth in supply of space and increase the costs of space from the level it would otherwise reach (Rosen and Shragowitz 1985). A lower square footage/higher cost market will affect employment expansion in sectors sensitive to space availability and cost.

Proponents and opponents of growth control measures refer to these theoretical effects at great length in their debates. Opponents of the measures argue that the economic costs in terms of higher housing prices, slower job growth, and income effects will be severe (San Diego Economic Development Corporation 1987). Proponents of such measures may cite the same job slowdown statistics to suggest that growth control measures may in fact achieve exactly what they set out to do--a smaller labor force with the added benefit of higher earnings for existing residents.

The theoretical arguments, however, do not answer the key questions that arise in discussions of growth management policy. These are first, how large, and thus how significant, are the direct impacts on housing prices, population growth, office rents, and employment growth, and second, what are the direction as well as magnitude of second order impacts, such as the effects of higher home prices on the supply of labor, business mix, the costs of goods and services, and income.

Empirical research to date has addressed two aspects of this primarily--the effects of residential land use controls on housing prices and the effects of nonresidential growth measures on rent levels and employment growth. Lillydahl and Singell 1987 provide a comprehensive review of empirical research on housing prices. There is strong evidence that land use controls that restrict the rate of growth of housing can have significant effects on housing prices. Rosen and Katz 1980, for example, compared prices across San Francisco Bay Area communities and found housing prices in communities with growth management systems or moratoria were raised 18 to 28 percent by these

measures. Other studies indicated the complexity of trying to determine growth control impacts on housing prices. Elliot 1981 found housing price increases to be highest (on the order of 35 percent) in communities where controls focused directly on the rate of construction, rather than on quality. Zorn, Hansen and Schwartz 1986 found that the City of Davis's growth control program, which includes measures to mitigate price effects by favoring low and moderate income projects, nevertheless had housing price levels about 10 percent greater than similar communities that did not control growth. In contrast, work by Miller (Miller 1986) on the Boulder housing market suggests that strong policies favoring affordable housing may mitigate the overall price effects of a growth control ordinance.

Work on nonresidential caps is much sparser. Rosen and Shragowitz used an econometric analysis to analyze the potential impacts of a cap on office square footage in the City of San Francisco on employment growth, income, rents and property taxes (Rosen and Shragowitz 1985). They apply their model retrospectively and find that had the city had a severe cap in building permits between 1974 and 1984, total office stock would have been 20 percent below the actual level reached in 1984. The impacts of the square footage reduction (and related rent increases) on job level would have surprisingly small--2.7 percent below a base case for 1984 with no building caps. Impacts on rents and revenues, however, were much more severe, dropping property tax revenues by 33 percent and raising rent levels by 44 percent. Thus, a rather small decrease in

employment levels (and presumably in growth related problems such as traffic congestion) would be bought at a relatively high cost in terms of lost property tax revenues. The major benefits of the policy would accrue to existing property owners through rent and property value increases.

Other work emphasizes the role that factors beyond the locality play in determining the severity of growth control impacts. Kroll argues that employment effects of nonresidential growth restrictions would be muted in San Francisco Bay Area suburbs in the mid-1980s because heavy overbuilding has resulted in vacancy rates exceeding 20 percent (Kroll 1986b). Dowall and Landis point to the difference in the price effects of housing restrictions depending on the policies of surrounding communities (Dowall and Landis 1981). Price increases locally and regionwide will be smaller if neighboring communities do not restrict supply, allowing new construction to shift to a nearby location.

Little empirical work has been done on the impacts of housing prices on employment growth, income levels and unemployment. Theoretical work by Rubinfeld suggests that land use regulations directed towards the housing supply may affect the number of jobs, wages demanded and paid, and commuting patterns in suburban communities (Rubinfeld 1978). Suburban housing restrictions could either decrease local employment growth or could increase commuting from the central city and exurban areas. Housing restrictions are likely to slow job growth regionwide, but the smaller employment base may carry higher wages and lower unemployment levels, as labor force growth also slows.

Some exploratory work done in the course of our research on San Diego indicates that the link between housing prices and job growth is a weak one at best. For example, all of the major U.S. metropolitan areas receiving strong high-tech employment growth in the first half of the 1980s also had very high housing prices even prior to that growth.¹ The Rosen/Shragowitz analysis indicates that many job sectors may be quite insensitive to square footage costs as well. On the other hand, common sense tells us that at some point severe restrictions on housing and office/industrial expansion, especially if prevalent regionwide, must have significant effects on both the rate of population growth and the growth and composition of the employment base of a region. The key question for San Diego, then, is the role real estate factors play in the region's economy, and whether measures directed to land use can successfully divert the problems of growth without serious distortions to the housing market and economic base.

III. Growth and Growth Concerns in San Diego

San Diego is a growing metropolitan county in a state that has also experienced strong growth in the 1980s. The county's rate of population and housing growth have far exceeded growth in the state or nation. Since 1980, San Diego's population has grown at about 2.7 percent annually, compared to statewide annual population growth of 2.0 percent annually and a U.S. rate of under 1.1 percent annually (see Table 1). San Diego's employment growth has been equally strong. Civilian jobs in San Diego County have increased at an annual rate of 4.9 percent in the

TABLE 1: COMPARISON OF INDICATORS OF GROWTH IN SAN DIEGO, THE STATE AND THE NATION, 1980-87

	SAN DIEGO COUNTY		SAN DIEGO CITY		CALIFORNIA		U.S.	
	1980	1987	1980	1987	1980	1987	Ann. Rate of Change	Ann. Rate of Change
Population	1,861,846	2,240,659	876,000	1,031,800	2.37%	1.99%	1.99%	1.05%
Housing	718,211	856,700	341,575	402,600	2.38%	1.75%	1.75%	1.82%
Employment	722,500	1,011,000	358,469	573,853	6.95%	2.64%	2.64%	1.79%

Sources: Statistical Abstract of United States 1988, Bureau of Census;
 General Social and Economic Characteristics 1980, Bureau of Census;
 Population and Housing Estimates for California Cities and Counties 1980, 1987,
 Department of Finance, Population Research Unit;
 Annual Averages of Monthly Labor Force Data for Counties 1970, 1980,
 Employment Development Department, Employment Data and Research Division;
 Monthly Labor Review, U.S. Department of Labor, Bureau of Labor Statistics, May 1988;
 Housing Completions, Current Construction Reports, U.S. Department of Housing
 and Urban Development, April 1988;
 Series 7 Regional Growth Forecast, San Diego Association of Governments, 1987.

1980s, compared to a California annual rate of 2.6 percent and a U.S. rate of 1.8 percent.

Both residential and nonresidential building activity have been strong in the county. San Diego County has just over 8 percent of the state's population but has accounted for over 10 percent of the state's population growth and almost 14 percent of the state's residential building permit value in the 1980s (Kroll 1986a). Despite rapid housing construction, the county has absorbed at least as much housing as it has added, according to housing stock estimates by the state Department of Finance (see Table 2).

San Diego's nonresidential building activity appears less extreme compared to the rest of the state. The county accounted for almost 12 percent of employment growth in the first half of the 1980s but for less than 8 percent of the value of California's nonresidential building permits (Kroll 1986a). Nevertheless, office and industrial space have expanded rapidly in the county in the 1980s. Vacancy rates for both office and industrial space in the county were close to 25 percent in 1986 and 1987 (San Diego Economic Development Corporation 1987b and Greater San Diego Chamber of Commerce 1987), rates significantly above statewide averages.

The City of San Diego is the county's largest city, and with a population of 1 million, accounts for 46 percent of the county's population. The city is large geographically as well, covering 320 square miles, 8 percent of the county's land base. As the county's central city, its population has grown less rapidly than countywide, but still at a strong 2.4 percent

TABLE 2: HOUSING STOCK GROWTH AND ABSORPTION, SAN DIEGO COUNTY, 1980-19

LOCATION/YEAR	HOUSING STOCK	OCCUPIED HOUSING	ADDED FROM PREVIOUS PERIOD	ABSORBED FROM PREVIOUS PERIOD	ABSORBED RELATIVE TO ADDED
SAN DIEGO COUNTY					
1980	720,346	670,094			
1987	857,098	809,342	136,752	139,248	101.8%
1988	894,333	846,164	37,235	36,822	98.9%
CITY OF SAN DIEGO					
1980	341,928	321,060			
1987	402,604	382,342	60,676	61,282	101.0%
1988	416,423	396,948	13,819	14,606	105.7%

Source: Computed by authors from data provided by the California Department of Finance (telephone communication).

annually, while the city's employment growth rate has exceeded the county's, expanding at almost 7 percent annually. This typical pattern of development involving the separation of workplace from residences has contributed to countywide increases in traffic that mirror changes occurring throughout Southern California. As shown in Figure 1, between 1980 and 1985 population in San Diego County grew by about 11 percent, the number of licensed drivers grew by 14 percent, and annual vehicle miles traveled increased by 33 percent. Not only transportation systems but social facilities, and especially schools, have been strained by this pace of growth (Rick 1978).

Rapid growth has not proceeded unquestioned by any means in San Diego County. Small communities, such as the City of Del Mar have had severe building restrictions for a decade or more, while state and local limits related to coastal zone management have also restricted building activity in a number of areas of the city and county since the 1970s (Rick 1978). Growth management for the City of San Diego was a subject of debate throughout the 1970s. Proposals covered a range of approaches--moratoria on new permits in specific development areas; a Sierra Club initiative restrict building permits until growth slowed to the national rate of increase; or more growth accomodating measures to allow for infrastructure provision in areas where new growth will occur (Stepner 1986). In 1980, the City of San Diego adopted a general plan which set aside portions of the city as an "urban reserve," allowed development in "planned urbanizing" communities only in conjunction with the "orderly extention of public facilities" (often paid for by new development), and encouraged infill in

Figure 1: Percentage Change in Indicators of Travel Demand in San Diego County, 1980-85

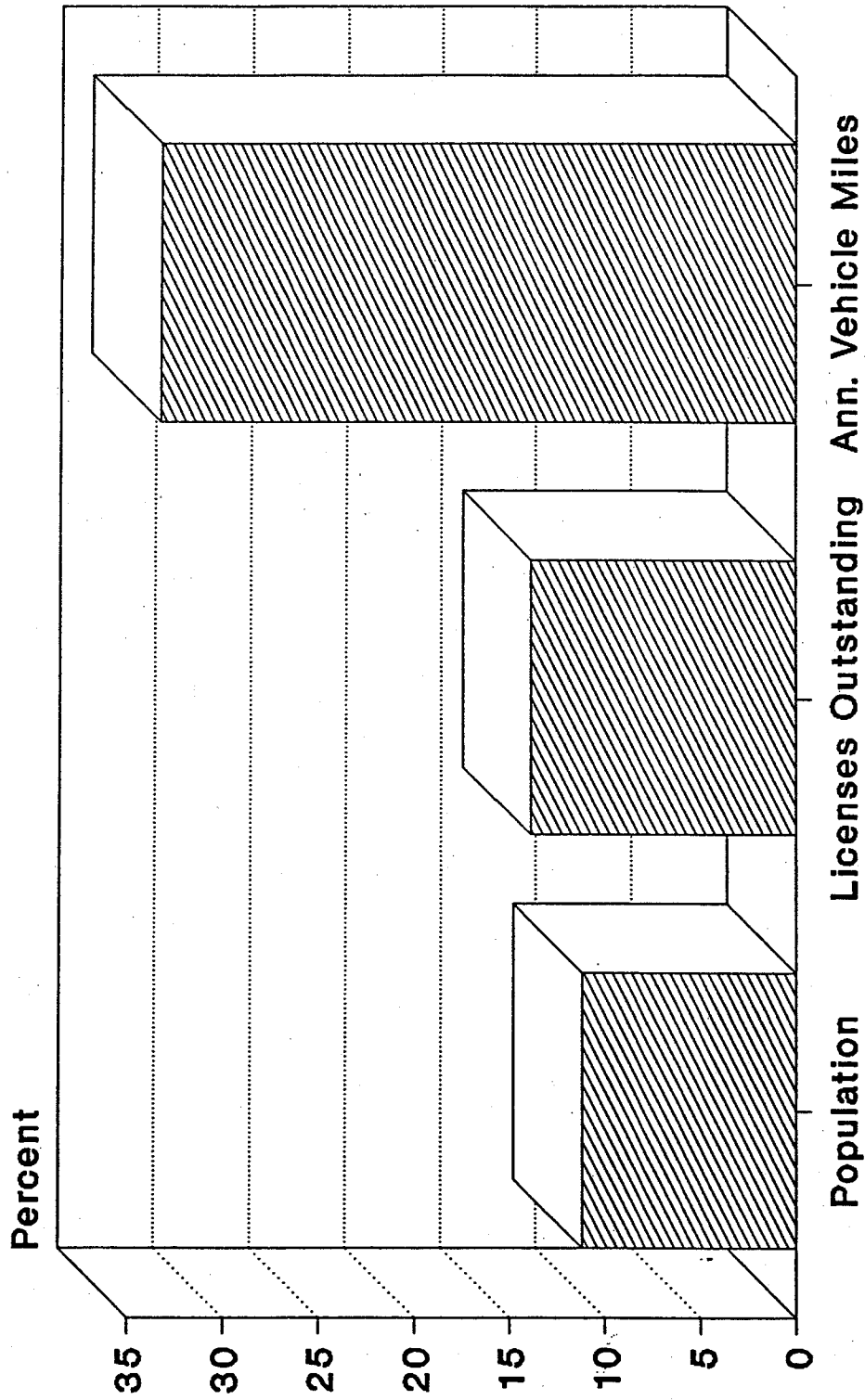

Population Licenses Outstanding Ann. Vehicle Miles
 Source: CREUE, using data from the California Department of Finance, the Department of Motor Vehicles, and CALTRANS.

existing "urbanized communities" (Stepner 1986). This plan was quite successful in the newly developing portions of the city, but led to infill in older urban areas without providing for expansion and maintenance of the communities' existing infrastructure capacity (Colburn 1986).

Since 1980 growth control has become far more than a set of proposals in San Diego's cities and the surrounding county area. A survey of county residents, commissioned by SANDAG and implemented in early 1987 found widespread concern with growth and its perceived impacts in the region. An open-ended question on what people liked least about living in San Diego found the top three areas of concern to be traffic congestion (mentioned by 35 percent of respondents), too many people (22 percent) and too rapid growth (19 percent). When asked specifically about concerns arising from the rate of growth, the three most frequently mentioned factors were overcrowding/congestion at public places (31 percent), traffic congestion (14 percent) and the impact on public services (8 percent). While less than one fourth of respondents favored a government policy actively limiting growth, more than half favored planning for growth, and less than 5 percent wished to see government actively promoting growth (Analysis Research Limited 1987).

While expressed sentiments appeared to favor managing, rather than limiting growth, growth control policies have been adopted in many parts of the region in recent years. By mid-1987 residential building caps were in place in 3 cities (Oceanside, Carlsbad and Vista), 2 other cities (Encinitas and Solana Beach) had moratoria on residential development, 2 more cities (San

Marcos and El Cajon) had restrictions on multi-family permits, 1 city (Poway) had stopped issuance of letters of sewerage availability, and 1 other city (Escondido) had residential limitations that restricted rezoning to higher density levels. In addition, Del Mar had added planning and voting requirements for commercial development to its already restrictive residential zoning policies. Thus, apart from the City of San Diego, 11 of the county's 18 cities had significant residential growth limitations in place (SANDAG 1987).

By 1987, both the City of San Diego and San Diego County were deeply involved in growth management considerations as well. The county had instituted a multi-jurisdictional task force to examine growth concerns affecting the entire region, while the city appointed a Citizen's Advisory Commission on Growth and Development (CACGD) to examine goals and policy options for the City of San Diego. In April 1987 the first of several versions of an interim development ordinance (IDO) for the City of San Diego came under consideration. The IDO was designed to regulate the rate at which building permits were issued and the locations for which permits could be obtained over an 18 month period, until more permanent policies addressing growth issues could be adopted. The council accepted the ordinance in principle in June 1987, and the details of its implementation were worked out over the following summer. In the months following the adoption of the IDO, citizen initiatives qualified for the November 1988 ballot in both the City of San Diego and San Diego County. The "Quality of Life" initiative (in the city) and the Rural

Preservation and Traffic Control Initiative (county) would place very severe building caps on the city and unincorporated county unless major improvements were to occur in factors such as air quality, sewage treatment and system capacity, water supply, solid waste disposal, and traffic levels (Citizens for Limited Growth 1987a and 1987b).

The planning activity that took place in the city of San Diego with regard to growth management during 1987 and 1988 was influenced by this political climate. The planning department and CACGD devoted resources both towards trying to understand the economic ramifications of any growth control measures and towards developing an alternative to the initiatives that would meet the citizen's apparent desire for some type of growth limit while also realistically addressing the transportation, infrastructure and environmental problems faced by the city. The analysis reported here was funded by the City of San Diego to provide information on the ramifications of alternative growth control policies.

IV. A Regional Analysis of Residential Caps in the City of San Diego

Although initially conceived as a means of evaluating a number of alternative approaches to growth management, our research ultimately was shaped by the political requirements of the City of San Diego to understand the implications specifically of residential building caps. Our analysis was designed to address several questions, including:

- a) the impacts of residential building caps on housing.

- prices,
- b) the impacts of residential building caps on employment growth,
 - c) the effects of any job impacts on the industrial and occupational mix of employment in the region, and
 - d) the effects of changes in housing production on the mix and affordability of housing.

The questions are complex ones, and the research addressed these questions using a variety of techniques. The full project involved the use of a short term hedonic housing price model, a multi-regional analysis across major U.S. metropolitan areas influenced by high-technology industries, a time-series model of the San Diego economy, a shift-share model forecasting alternative growth scenarios, an intra-regional location analysis, and a matrix analysis based on simple multipliers to identify some of the implications of change for the regional labor force mix. The structure of these models and their results are reported in detail in Landis, Kroll, Griesenbeck, Belzer, Evrengis, Stroshane and Leigh-Preston 1988 and in a forthcoming working paper. The discussion that follows focuses primarily on the contribution of the time series analysis to understanding the implications of a residential building cap policy on the region.

A. Modeling the San Diego Economy over Time

In developing a long term picture of the San Diego economy we were concerned not with the question of how building caps would have affected housing prices had they been imposed in 1986 and the first half of 1987, but in the longer term, how the effects of caps would be felt compared to likely future building

patterns in the 1990s. Thus, we needed to be able to forecast how growth might occur absent any new controls. A set of time series and multiplier models of San Diego employment and related economic factors allowed us to identify the structure of the economy and the factors driving economic growth, to examine the relationship of housing prices and housing construction activity to the region's economy, and to describe the effects of employment growth and building activity on housing prices. Because the economy's economic linkages are largely regional in scope, the analysis focuses on regional impacts of the city's residential growth policy, rather than on impacts as they might be felt within the city alone.

The time series analysis involved both econometric models calibrated on a data series covering 21 years and multiplier estimates with multiplicative factors calculated from historic trends. The analysis incorporates several different model elements (see Figure 2). First, sectors driven in large part externally are calculated using U.S. trends as dependent variables. These include high technology manufacturing, other manufacturing and tourism. Other economic sectors are driven largely by changes in San Diego's externally driven sectors. Total or basic employment is a key dependent variable in calibrating econometric models of population, per capita income, housing prices and rents. Housing permit and additions to housing stock are calculated using multipliers drawn from historic experience.

The econometric equations that form the basis of the

Figure 2: Diagram of Time Series Analysis

SAN DIEGO ECONOMY

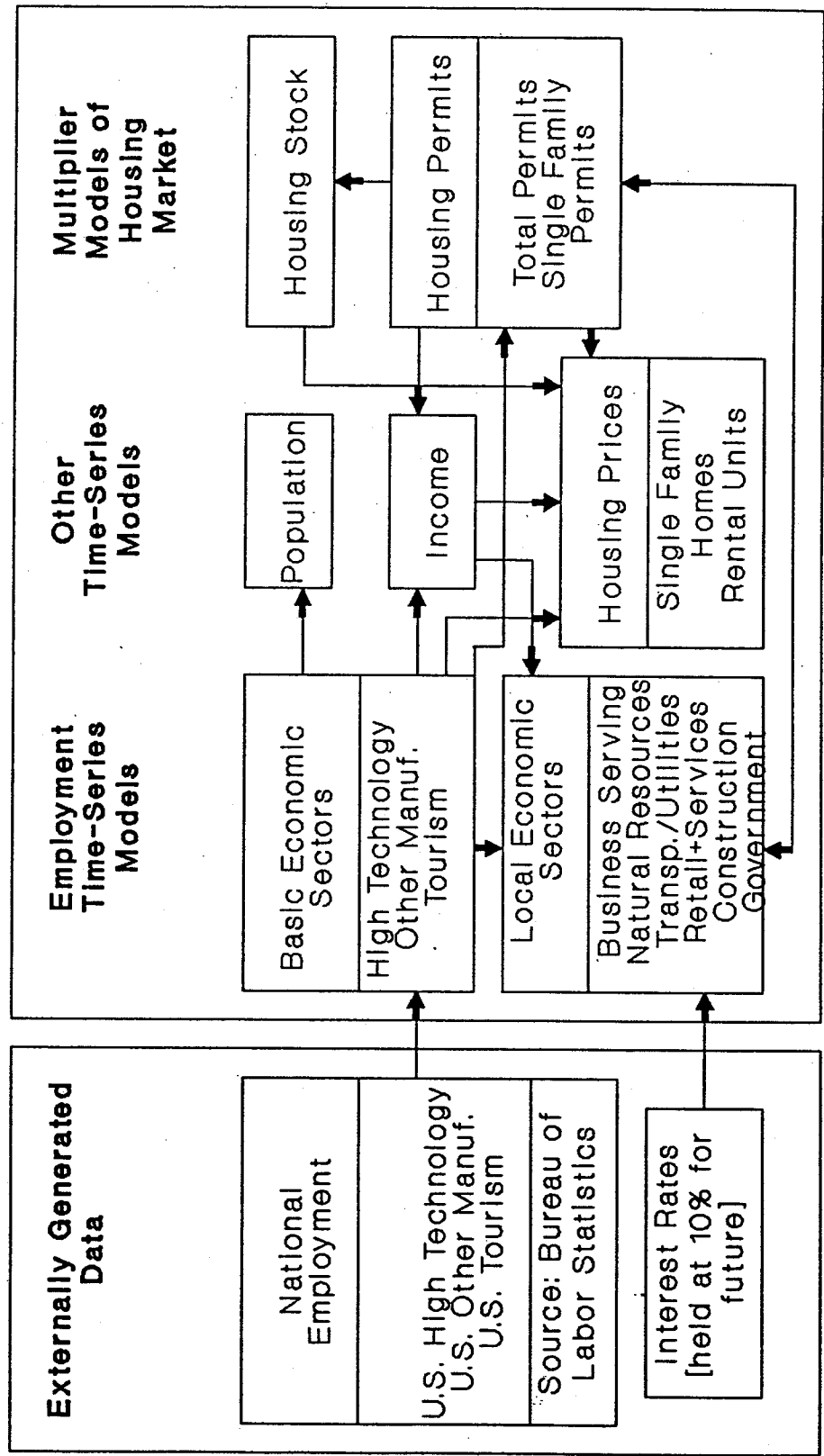

Source: Center for Real Estate and Urban Economics.

forecasting model are linear and calculate absolute employment levels rather than employment change in a given year. The variables are mostly untransformed. Equations for different factors generally interact recursively, rather than simultaneously--a reflection of our observation that lags occur between many effects (e.g. between issuance of a building permit and the employment created by construction activity).

In the course of developing the models, we examined other structural forms for modeling, including non-linear model forms (e.g. log on log) and models based on the annual increment of change, rather than absolute employment levels (e.g. the annual change in tourism employment explained as a function of the annual change in U.S. tourism employment). We rejected these structures for the final model because they proved to be very unstable for forecasting. However, the relationships identified through early modeling efforts were important in defining which sectors were export based and which sectors were most influential in contributing to building permit activity.

Appendix A gives a detailed description of data sources used. Historic employment data for San Diego and the United States is from County Business Patterns, with the exception of government data (drawn from the California Employment Development Department figures). We use U.S. Bureau of Labor Statistics forecasts to determine rates of future employment growth in aggregate sectors at the national level. Population, housing stock, and per capita income are from California's Department of Finance. Housing permit data came from publications from Security Pacific Bank. Home price and rental level indices were

constructed from data compiled by the Greater San Diego Chamber of Commerce, while interest rate data was drawn from a CITIBASE series on the secondary market yield on FHA insured loans.

B. Employment Analysis

The analysis aggregates economic activity in the San Diego region into nine sectors--high technology manufacturing, other manufacturing, natural resources, tourism, construction, transportation/communications/utilities (TCU), business-serving, local-serving, and government. The detailed categories composing each of these aggregate sectors are shown in Table 3. The use of aggregate sectors enabled us to track basic trends without having to account for the severe fluctuations that might occur in a single 2-digit category due to changing conditions for 1 or 2 large employers.

Figure 3 illustrates the basic structure of the San Diego economy while Table 4 gives the model characteristics in detail for the employment equations. Analysis of factors inducing growth in key sectors indicates that three aggregate sectors, high technology manufacturing, other manufacturing, and tourism are spurred directly by the strength of those sectors nationally. Existing size of the industries within San Diego (i.e. last year's employment) also contributes to employment levels in each of these basic sectors in future years. While the high technology aggregate appears to be entirely export based, more interaction within the local economy occurs with the other two aggregate export sectors. Non-high tech manufacturing jobs, in addition to being influenced by U.S. non-high tech sectors are

TABLE 3: DEFINITIONS OF THE SECTORS FORECASTED BY EMPLOYMENT MODELS

SAN DIEGO COUNTY EMPLOYMENT IN:	IS COMPOSED OF THESE INDUSTRY SECTORS:
HIGH TECHNOLOGY	Chemicals, machinery except electrical, electrical and electronic equipment, transportation equipment, instruments
OTHER MANUFACTURING	All manufacturing other than high technology
NATURAL RESOURCES	Agricultural services, fishing and mining
TOURISM	Restaurants, hotels, amusement and recreation places, and museums
CONSTRUCTION	All construction sectors
TRANSPORT., COMM., & UTILITIES	All transport, communications and utilities sectors except local transport
BUSINESS SERVING	Wholesale, banking, savings and loans, and business services
LOCAL SERVING	All retail except restaurants, local transport, finance, insurance and real estate, except business-related, and services except tourism-related
GOVERNMENT	Federal, state, and local governments

Source: Center for Real Estate and Urban Economics.

Figure 3: Structure of San Diego County Economy

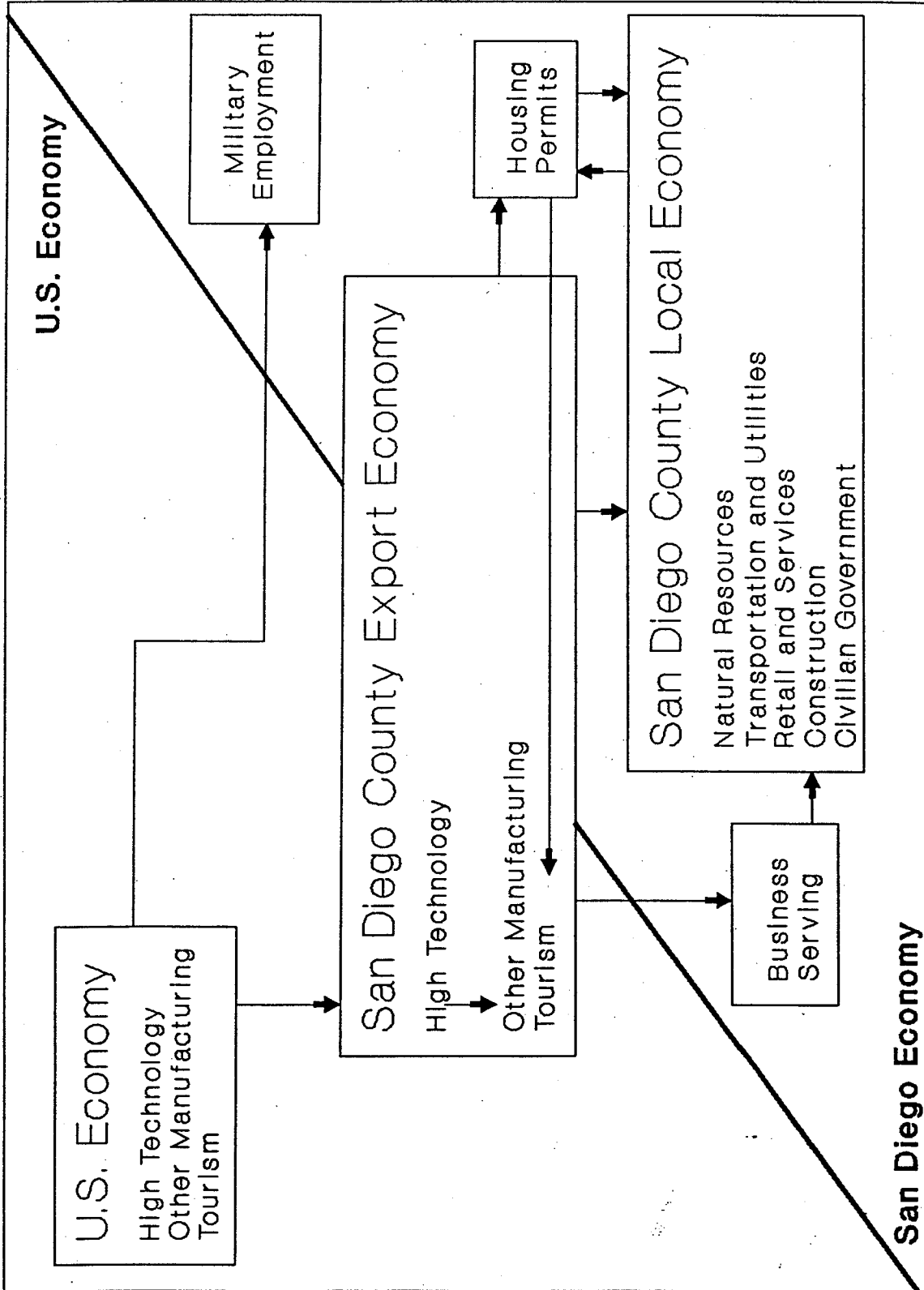

Source: Center for Real Estate and Urban Economics

TABLE 4: SUMMARY OF EMPLOYMENT TIME-SERIES MODELS OF THE SAN DIEGO ECONOMY

SAN DIEGO COUNTY EMPLOYMENT IN	DEPENDS ON:				
	U.S. Sectors	Employment Last Year Same Sector	Other S.D. Sectors	Building Activity	Other Factors
HIGH TECHNOLOGY *	Current U.S. High Tech Jobs	County High Tech Jobs Last Year			
Adjusted R2: .9526					
Durbin Watson: 2.276					
Coefficient:	.0069	.9259			
(t statistic):	(3.7969)	(17.4076)			
OTHER MANUFACTURING *	Current U.S. Other Manuf.	County Other Manuf. Last Year	Current S.D. High Tech Jobs		
Adjusted R2: .9464					
Durbin Watson: 1.682					
Coefficient:	.0017	.6133	.1291		
(t statistic):	(3.3236)	(4.2142)	(2.4240)		
TOURISM	U.S. Tourism	County Tourism Last Year			County Per Capita Income
Adjusted R2: .9914					
Durbin Watson: 2.089					
Coefficient:	0.0067	0.3848			6.3246
(t statistic):	(3.4862)	(2.9289)			(1.7583)
NATURAL RESOURCES		County Nat. Res. Last Year	Current S.D. Manu- facturing	Last Year's S.F. Permits (sq.root)	Interest Rates^2 2 Yrs Ago
Adjusted R2: .9550					
Durbin Watson: 2.040					
Coefficient:		0.3727	0.0617	8.1200	-5.0684
(t statistic):		(1.8454)	(3.6826)	(2.2248)	(-1.8653)
CONSTRUCTION			Current S.D. Manuf. + Tourism	Current Bus. Serving Growth	Last Years Housing Permits
Adjusted R2: .9540					
Durbin Watson: 1.552					
Coefficient:			0.1804	0.6391	0.1976
(t statistic):			(13.0168)	(4.4552)	(3.7110)
TRANSPORT., COMM., & UTILITIES		TCU Jobs Last Year	Current S.D. Nat. Res. Jobs		Last Years Housing Permits (sq.root)
Adjusted R2: 0.9754					
Durbin Watson: 1.702					
Coefficient:		0.7498	0.7754		9.5200
(t statistic):		(9.7752)	(3.0676)		(2.0630)

(continued)

TABLE 4: SUMMARY OF EMPLOYMENT TIME-SERIES MODELS OF THE SAN DIEGO ECONOMY (continued)

SAN DIEGO COUNTY EMPLOYMENT IN	DEPENDS ON:				
	U.S. Sectors	Employment Last Year Same Sector	Other S.D. Sectors	Building Activity	Other Factors
BUSINESS SERVING			Current Tourism	Current High Tech	Interest Rates (Last Year)
Adjusted R2: 0.9827					
Durbin Watson: 1.685					
Coefficient:			1.0032	0.7043	-1207.3
(t statistic):			(7.9276)	(3.7163)	(-1.7896)
RETAIL TRADE AND SERVICE			Current Tourism Jobs	Current High Tech Jobs	
Adjusted R2: 0.9955					
Durbin Watson: 2.334					
Coefficient:			2.6786	0.3847	
(t statistic):			(18.9102)	(2.29)	
GOVERNMENT		S.D. Gov't Jobs Last Year	Current Total S.D. Private Jobs		
Adjusted R2: 0.9421					
Durbin Watson: 2.245					
Coefficient:		0.8883	0.0250		
(t statistic):		(9.3581)	(1.9111)		

* In the Moderate Forecast, forecasts for these sectors are developed exogenously, based on the U.S. moderate forecasts and competitiveness coefficients derived from a shift-share analysis.

Note: Does not include self-employed persons, employed in the armed forces, or in agricultural production.

Source: Center for Real Estate and Urban Economics.

also influenced by high tech activity within the region-- apparently a number of firms exist as suppliers to high tech companies. The tourism sector, which includes activities such as eating and drinking places, not surprisingly is influenced by local per capita income levels as well as by tourism activity at the nationwide level.

We explored several means of identifying the influence of real estate factors on the region's economy. Whatever form of model was used (linear/non linear; total employment/change on change), we found no evidence of a direct negative relationship between housing prices or price levels relative to the U.S. on the rate of growth or level of employment in the San Diego region. This lack of evidence could indicate a) that no effect exists, b) that the absolute or comparative measures we were using were not accurate enough, disaggregated enough, or in the appropriate context to identify a relationship that indeed exists, or c) it was not possible to separate the negative effects of high prices on job growth from the simultaneous, strongly positive effect of employment growth on housing prices.

In contrast, the effects of housing construction activity, as measured by the level of building permits the previous year, clearly influenced growth in a number of sectors. Construction activity was of course closely linked to housing permit levels but was also influenced by nonresidential growth, as measured by basic employment growth and closely linked business serving activities. Natural resource sectors, often export based activities in many economies, in the San Diego economy proved to be largely local serving and very closely linked to building

activity. Distributive activity (TCU) was also closely linked to building permit levels. Retail Trade and Services and Tourism were indirectly linked to housing construction as well, through the effects of housing permits on per capita income levels, which in turn affected employment levels in these sectors.

C. Population and Income

Table 5 indicates the models used to forecast per capita income and population levels. The economic sectors showing clear links to the region's per capita income were high tech employment and tourism. It is interesting to note that despite much lower average wages in tourism than in high tech manufacturing, the coefficients for the two sectors are almost identical, indicating the importance of proprietor's income as well as wage levels in determining total income levels.

Calibration of the population model was constrained by the fact that the annual figures available are themselves estimates based in part on building activity. The model selected for our analysis ties population to basic employment levels, a reasonable assumption for a rapidly growing economy. Some alternative models are discussed in Appendix B.

D. Modeling Housing Prices and Building Activity

The analysis covers several components of the housing market. These include housing prices, total and single family housing permits, and housing stock.

1. **Housing Prices**--Econometric models are used to identify the effect of building activity and employment levels on home prices. Relative housing prices are affected by the level of

TABLE 5: FORECAST MODELS OF ECONOMIC FACTORS RELATED TO SAN DIEGO EMPLOYMENT

ECONOMIC FACTOR	DEPENDS ON:				
	EMPLOYMENT LEVELS	EMPLOYMENT CHANGE	BUILDING ACTIVITY	OTHER FACTORS	
TIME SERIES MODELS					
POPULATION	S.D. Manuf. & Tourism Jobs				
Adjusted R2:	.9743				
Durbin Watson:	1.063				
Coefficient:		7.6380			
(t statistic):		(27.5522)			
PER CAPITA INCOME	S.D. High Tech Jobs Last Year	S.D. Tourism Jobs Last Year	Last Year's Housing Permits		
Adjusted R2:	.9626				
Durbin Watson:	2.109				
Coefficient:	0.0090	0.0089	0.0128		
(t statistic):	(3.2954)	(4.0340)	(9.0164)		
RELATIVE HOUSING PRICES (Single Family Sales)	(see other factors)		Last Year's Housing Permits	Housing Stock/ Total Jobs	Per Capita Income Last Year
Adjusted R2:	.9497				
Durbin Watson:	1.552				
Coefficient:			-0.0059	-750.8646	0.3463
(t statistic):			(-4.8374)	(-4.1806)	(3.5452)
RELATIVE HOUSING PRICES (Rents)	(see other factors)		Housing Permits Last 2 Years	Housing Stock/ Total Jobs	Per Capita Income Last Year
Adjusted R2:	.9268				
Durbin Watson:	1.140				
Coefficient:			-0.0015	-293.6826	0.1954
(t statistic):			(-3.4653)	(-2.6735)	3.2049

(continued)

TABLE 5: FORECAST MODELS OF ECONOMIC FACTORS RELATED TO SAN DIEGO EMPLOYMENT (continued)

ECONOMIC FACTOR	DEPENDS ON:			
	EMPLOYMENT LEVELS	EMPLOYMENT CHANGE	BUILDING ACTIVITY	OTHER FACTORS
MULTIPLIER GENERATED FORECASTS				
TOTAL PERMITS--UNCAPPED	Minimum of (8000) or (2 * Change in (Manuf. + Tourism + Bus. Serv.))			
TOTAL PERMITS--CAPPED	Minimum of (Forecast Permits) or (County Share of Forecast Permits (0.5851) + City Cap)			
S.F. PERMITS--UNCAPPED	0.66 * County Share of Permits + 0.42 * City Share of Permits (0.34 * City Share for Urban Caps)			
S.F. PERMITS--CAPPED	0.66 * County Share of Permits + 0.42 * City Share of Permits (0.34 * City Share for Urban Caps) } Calculated from Capped Housing Permits			
HOUSING UNITS	Last Year's Units + 0.8 * Last Year's Permits			

Source: Center for Real Estate and Urban Economics.

building activity, as measured by building permits issued in the previous year, by the overall availability of housing, as measured by the ratio of total housing stock to employment levels, and by per capita income. (Vacancy rates were not useful as an alternative measure of availability both because time series measures of the necessary length were not available and because forecasts of vacancy variables were difficult to accomplish reliably). The models indicate that housing prices and rents are lower when building activity is high and when housing stock expands more rapidly than the job base. Prices become higher when housing stock expands slowly and when real per capita income increases.

2. **Building Permits**--The housing permit forecast is based on multiplier estimates rather than econometric models. This approach avoids two pitfalls. First, econometric analyses show building permit levels fluctuating sharply with interest rates. Thus, the reliability of any forecasts would depend on the accuracy of interest rate forecasts. Second, wide fluctuations in building permit activity in San Diego that could not be explained by traditional economic measures made it impossible to calibrate an econometric model with reliable forecasting capability. The model selected uses a multiplier against added jobs in high-tech, other manufacturing, tourism, and business services (the four sectors unrelated to housing production in the employment models). Long term averages for the San Diego region indicate that historically, building permits have run at the level of between 1.5 and over 2 housing units for every new job in these four sectors combined. The results presented here use a

multiplier of 2, a level which gives a population to housing ratio of between 2.6 and 2.7 over the forecast period (in the unconstrained cases). The major impact of this approach on our analysis is to reduce some of the fluctuations induced by interest rate variability and by ideosyncratic characteristics of the building climate in San Diego. This would tend to reduce the magnitude of our findings on the construction and housing price impacts of a building cap in peak years. (The effects on our findings of altering the multiplier level is discussed in Appendix B).

The share of permits in single family housing is also forecast using multipliers. Based on historic experience, two thirds of permits issued outside the city and between one third and two fifths of permits in the city are for single family housing.

In forecasting building permit activity in years when a constraining cap might be in effect, spillover considerations must be taken into account. In reality, a significant building cap in the City of San Diego could have repercussions for building activity throughout the rest of the county. At one extreme, if the county and neighboring cities are accomodating, much of the building activity diverted from the city might occur in neighboring places, thus sharply modifying the regionwide price and employment impacts of a cap. At the other extreme, a strong cap in the city could induce retaliatory responses in neighboring communities, leading to further decreases regionwide in building activity. Our analysis assumes that neither extreme

occurs. The results described here assume that no spillovers occur. Thus, with or without caps in the City of San Diego, the rest of the county will continue to issue about 60 percent of the total building permits forecast in the unconstrained model. While the absence of spillover housing production theoretically may exaggerated growth control impacts, we do not believe this is the case for the City of San Diego analysis because of the prevalence of growth concerns and restrictions elsewhere in the county.

3. **Housing Stock**--Additions to housing stock are directly related to but are not the simple addition of new building permits to existing stock. Historically, not all permits have been built out, for whatever reason. An econometric model relating housing stock additions to permit activity indicates that additions to stock in the current year equals 0.5 times building permits in the preceding year plus 0.3 times building permits two years previously. In actual experience, this proves to be almost identical to adding 80 percent of last year's permits in a given year. Because building permits were not predicted using an econometric model, we chose to use this 80-percent multiplier instead for assessing increases in the housing stock.

In sum, then, the housing portions of the model indicate that housing construction occurs in response to growth in economic activity, while home prices are affected by a variety of factors ranging from employment growth to income levels and housing availability.

V. Forecasting San Diego's Unconstrained Future

A key factor in determining how extensively building permit caps will affect the local economy is the assessment of the level of growth expected for the San Diego region in coming years. As noted earlier, employment and population have expanded very rapidly in San Diego in the 1980s. Recent concern with the rate of growth relates not only to traffic levels but to the perception that building permit levels have doubled in recent years from the historic rates of the past decade and a half. Residents fear that growth will continue at this accelerated pace. The purpose of the employment forecast is to see if indeed the levels of today are likely to persist. Our findings indicate that this is not the case.

San Diego's recent growth has been a function of its specialization in sectors that have enjoyed strong rates of growth in the United States over the past decade, and its diversification into at least two strong sectors which are not closely linked (high-tech manufacturing and tourism). While the region may continue to show a high level of innovation in new, rapidly expanding industries, its growth is most likely to be affected by the rate at which its basic sectors expand in the U.S. as a whole. High tech and other manufacturing sectors will be affected by the level of demand for goods nationwide and the ability of U.S. firms to compete with foreign producers. Tourism growth in San Diego is dependent on the overall level of prosperity nationwide.

Table 6 shows three alternative forecasts for the San Diego County economy over the next decade. The low growth scenario

TABLE 6: COMPARISON OF EMPLOYMENT GROWTH SCENARIOS BY MAJOR SECTOR FOR SAN DIEGO COUNTY, 1985-1995

SECTOR	1985 Base	1995 FORECASTS AND 1985-1995 GROWTH RATES					
		Low Growth Scenario		Moderate Growth Scenario		High Growth Scenario	
		1995	1985-95 % Change	1995	1985-95 % Change	1995	1985-95 % Change
High Technology	88,003	88,385	0.4%	98,869	12.3%	115,813	31.6%
Other Manufacturing	33,175	31,424	-5.3%	35,743	7.7%	44,053	32.8%
Tourism	81,456	105,751	29.8%	107,170	31.6%	110,656	35.8%
Business Serving	103,739	129,977	25.3%	138,785	33.8%	154,214	48.7%
Natural Resources	6,736	6,972	3.5%	8,464	25.7%	11,190	66.1%
Construction	47,226	39,145	-17.1%	43,466	-8.0%	52,202	10.5%
Transportation/Util.	28,453	32,586	14.5%	36,427	28.0%	42,990	51.1%
Retail Trade/Services	256,503	323,289	26.0%	331,123	29.1%	346,978	35.3%
TOTAL PRIVATE EMPLOYMENT:	645,291	757,529	17.4%	800,047	24.0%	878,096	36.1%
CIVILIAN GOVERNMENT:	145,700	157,238	7.9%	161,309	10.7%	167,268	14.8%
POPULATION:	2,128,100	2,334,539	9.7%	2,458,447	15.5%	2,677,952	25.8%
HOUSING UNITS:	787,194	925,043	17.5%	948,604	20.5%	993,144	26.2%
RELATIVE HOME PRICES (1985=100):							
Single Family Sales	100.00	131.88	31.9%	138.84	38.8%	150.71	50.7%
Multifamily Rents	100.00	108.54	8.5%	114.31	14.3%	123.62	23.6%
REAL PER CAP. INCOME (1967 \$s):	4,524	4,524	0.0%	4,672	3.3%	5,028	11.1%

Note: Does not include self employed, agricultural production, or military employment.

Source: Center for Real Estate and Urban Economics.

assumes that the U.S. economy grows at the moderate rate forecast by the Bureau of Labor Statistics (BLS) through the year 2000 (Bureau of Labor Statistics 1988), and that this affects growth in San Diego's basic sectors (high-tech, other manufacturing, and tourism) through the models shown in Table 4. The high growth scenario assumes that the U.S. economy grows at the high rate forecast by the BLS, again affecting manufacturing and tourism in the ways calibrated by the econometric models.

The moderate growth scenario is also based on the BLS moderate forecast for the U.S. economy. However, rather than using the time series models for the two aggregate manufacturing groupings, forecasts for these sectors are based on a modified shift-share forecast for San Diego. The shift-share model used assumes these two aggregate manufacturing sectors continue to show a strong, but converging advantage in their rate of growth over the U.S. rate of growth. For example, while high tech jobs in San Diego grew 22 percent faster than growth nationwide from 1980 to 1985, this advantage will shrink to 11 percent between 1985 and 1990 and to 5.5 percent in later years. This is consistent with the 1975 to 1985 experience, where the differential advantages for the San Diego economy began to narrow.

Because all three scenarios are based on BLS forecasts, they include a recession in 1990, which affects the expected rate of growth in the near term. However, the recession effects are much greater in the time series dependent forecasts (high and low scenarios) than in the shift-share forecast). In each of the

low, moderate, and high growth scenarios, the non-basic employment sectors are projected using the econometric models described in Table 4.

In our assessment, based on our qualitative understanding of the San Diego economy (a result of many interviews of business, government and labor representatives) as well as on the quantitative analysis described here, we think either the moderate or high growth scenario is likely to occur, while the low growth scenario is quite unlikely. It is also important to note that even our "high growth" scenario indicates that we expect growth to occur at a slower rate of increase than it has in the past decade. If the forecasts are too low and, as some fear or hope, San Diego continues to expand at its recent pace or faster, the impacts of building caps on the economy and especially on the housing market would be much more severe than the following discussion implies.

VI. The Impacts of Alternative Building Caps

With three alternative scenarios for the future, we were able to analyze the effects of three alternative building permit cap levels in the City of San Diego (12,000, 8,000, or 4,500 units) on the countywide economy. Under the low growth scenario, a cap as low as 4,500 may not reduce building levels from the expected market level, while under the high growth scenario, even the 12,000 unit cap would reduce permit levels in some years. Even the results of the most severe cap under high growth are fairly modest regionwide. Because we think this level of economic growth is quite likely, we focus much of the discussion

here on the results for the "high growth" scenario.

Apart from any effects of land use or permit allocation policies, it is important to note that the rate of inflation of housing prices and the growth of real income are affected by the rate at which the economy grows. Faster economic growth is likely to lead both to higher real levels of income, relative to prices in the U.S. as a whole, and to higher housing prices in the San Diego region. Relative home prices are projected to be substantially higher under high growth than under low growth. However, real per capita income is forecast to grow about 20 times faster under high than under low growth.

To understand the findings of the analysis, it is important to understand the underlying levels of building permit activity in San Diego County historically and in the future. Housing permit activity fluctuates widely over time, in response to changing growth levels in the economy and other factors such as interest rates. For example, between 1975 and 1985, housing permits in San Diego County varied from a low of 7,700 in 1982 to a high of 38,000 in 1985. Without dwelling unit cap restrictions in the City of San Diego, annual countywide housing permit activity could vary from a low of 8,000 units during the first half of the 1990s (under a low employment growth forecast) to as much as 27,000 units (under high rates of employment growth). Under high economic growth conditions, a 4,500 dwelling unit cap could reduce total building permits by almost 40,000 between 1989 and 1995.² If economic growth is more moderate during the early 1990s, the effects of the proposed dwelling unit caps on housing supplies would be substantially reduced, as is illustrated in

Figure 4.

Table 7 summarizes the effects of alternative residential building cap levels in the City of San Diego on the economy and housing market of San Diego County if the employment growth would otherwise be strong (the high growth scenario). The model results indicate that employment and population impacts of even a 4,500 unit building cap in the City of San Diego would be very small. The total percentage increase in private employment for the decade from 1985 to 1995 would be reduced by 1 percentage point, from 36 percent to 35 percent. A mere half percentage point decrease would occur in population growth rates for the decade, which would remain at about 26 percent.

Housing stock would no longer grow at a rate matching population growth (about a 26 percent increase between 1985 and 1995), but expansion of the housing stock would drop 3 percentage points, to 23 percent for the ten year period. Because San Diego County's housing stock is quite large, the impact on the overall housing market, in terms of price levels, can be expected to be small. Nevertheless, even regionwide, they are significant. Without caps, forecasts indicate that single family home prices would rise by 51 percent in a high growth situation, while caps would force prices up by an additional 3 percentage points, leading home prices to be on average 2 percentage points higher with caps than they would be without caps. Real per capita income (relative to U.S. prices, not San Diego housing-related prices) would rise by only 9 percent under a 4,500 cap instead of by 11 percent, leading to real percapita incomes at 2 percent

Figure 4: Forecasts of Total Permits for San Diego County, 1985-1995

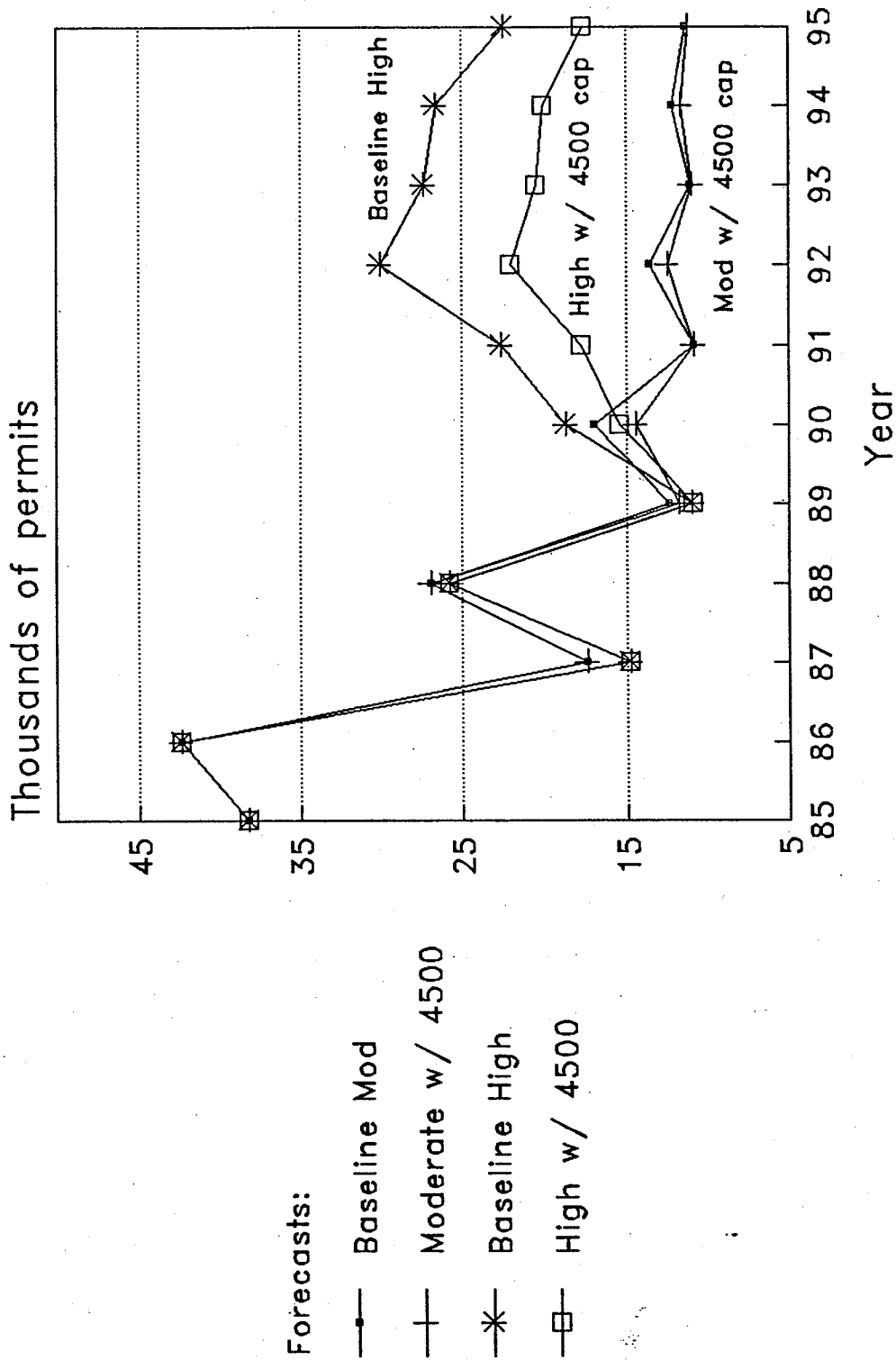

Source: Center for Real Estate and Urban Economics.

TABLE 7: SUMMARY COMPARISON OF GROWTH RATE FORECASTS
UNDER HIGH GROWTH

SECTORS AND OTHER CATEGORIES			
	BASELINE	8000 CAP	4500 CAP
INDUSTRY SECTORS			
High Technology	31.6%	31.6%	31.6%
Other Manufacturing	32.8%	32.8%	32.8%
Tourism	35.8%	35.3%	34.7%
Business Serving	48.7%	48.2%	47.7%
Natural Resources	66.1%	65.5%	64.1%
Construction	10.5%	9.1%	7.4%
Transport/Utilities	51.1%	49.9%	47.9%
Retail Trade/Services	35.3%	34.8%	34.3%
PRIVATE EMPLOYMENT	36.1%	35.6%	35.0%
GOVERNMENT	14.8%	14.6%	14.4%
POPULATION			
	25.8%	25.7%	25.5%
HOUSING UNITS			
	26.2%	24.9%	23.2%
RELATIVE HOME PRICES (1980=100)			
Single Family Sales	50.7%	51.9%	53.8%
Multi Family Rents	23.6%	24.3%	25.3%
REAL PER CAPITA INCOME	11.1%	10.2%	9.1%

Source: Center for Real Estate and Urban Economics.

below the level that would otherwise be reached.

It is not surprising that a drop in housing stock of less than 3 percent would affect housing prices by an amount on the order of 2 percent and incomes at a similar level. Similarly, it is not surprising that employment and population levels are relatively insensitive to changes of this magnitude. Under strong growth and a 4,500 unit per year building cap, population per household would rise from 2.7 to 2.75 persons per household. It is easy to conceive of this type of adjustment occurring--it involves not a nightmarish image of families doubling up in single-family homes, but more moderate responses of 2 adults sharing an apartment each might otherwise inhabit alone, of adult children remaining at their parent's homes for an additional year or two before living independently, and of immigrant families continuing to live in extended family groups, rather than separating into smaller family units.

While the model cannot be used to disaggregate results among areas, other portions of the research (for example, the short term hedonic housing price model, reported in Landis, Kroll, Evrengil and Griesenbeck 1988) indicate that the cost and per capita income effects will not be spread evenly throughout the county or among population groups. First, if caps occur in the City of San Diego alone, they will certainly affect home prices in the city far more than in the county--probably on the order of 5 to 10 percent, or even higher in certain parts of the city. The areas where housing construction would otherwise occur most rapidly will feel the strongest housing price impacts. If the largest projects involve moderate priced homes then the cutbacks

in homes at this price level could have quite serious impacts on affordable housing while having less of an effect on the highest or lowest priced homes.

Income effects are likely to be felt most strongly in the sectors directly and indirectly linked to construction activity-- construction, natural resources, TCU, retail trade and services, and some tourism-related activities.

In conclusion, the model results seem to indicate that residential building caps are unlikely to significantly effect employment and population levels, at least through the mid 1990s, while they may have significant housing price and negative income effects on some segments of the population. Thus, it is likely that the underlying growth problems will not be addressed by residential building restrictions at all, while some costs to local population groups from the measures seem certain. Depending on how building caps are implemented, it is possible that they could even exacerbate some traffic and infrastructure problems, if people are forced to move further out to find affordable housing.³

VII. The Limitations of the Results

While the regional model in one sense is complex, with many different parameters, it also represents a major simplification of economic relationships. The inaccuracies of such models have been well documented for many years (see, for example, Lee 1973). How useful are these results, then, for making decisions about public policy? To answer this question, it is helpful to review some major limitations of the models and to discuss the

implications of these limitations for interpreting the model results.

First, the model components describe historic relationships. Forecasts from these models assume that these relationships will remain unchanged in the future. This is not an unreasonable assumption over a ten-year period. At the same time, it is not necessarily correct. Other counties (San Francisco and Contra Costa counties in the San Francisco Bay Area, for example) have undergone dramatic changes over the course of a decade in the composition of the employment base. In San Diego County, a potential transformation could occur if innovations change the structure of basic industry, possibly leading to far faster growth than is forecast by our high growth scenario. If this is the case, housing price and per capita income effects of a building cap may be underestimated.

A second error that could arise from the structure of the model is that, while housing prices were not found to directly affect employment growth, in a tighter housing market situation, employment effects might begin to appear. Under such circumstances, the employment and population impacts of housing restrictions might be greater than they appear in our model. Should this occur, we would expect the impacts to be felt differentially among sectors, affecting particularly those sectors that rely on low priced clerical and middle professional labor and that at the same time do not depend on a high quality environment to attract labor force or customers. Similarly, because good data was not available, we were unable to estimate

the effects of higher or lower wages on growth in different employment sectors. Thus, any effects of housing prices on the cost of labor are not included in our estimates.

A third concern is that the use of multipliers to estimate building permit and construction activity may underestimate peaks and troughs of building activity, thus underestimating the impacts of building restrictions on housing prices in peak construction years. Furthermore, again because of data limitations, we were unable to assess the impacts of nonresidential building activity on employment growth.

Despite these limitations, we feel the implications of the research are quite clear. In the course of our analysis, we did a great deal of sensitivity testing over the underlying assumptions in various equations. Even significantly different equations (e.g. more sectors showing sensitivity to building activity; housing permit models projecting housing growth at levels far above reasonable expectations) tended to give similar comparative results in terms of the effects of reduced housing production both on employment and on housing prices. Overall, employment and population impacts of residential restrictions were very slight, while housing price effects regionwide were stronger.

VIII. The Implications for Growth Control Policy

Our results indicate that residential building caps will certainly raise housing prices, while it is likely that the effects of caps on economic and population growth will be very small. While they may shift the burden of infrastructure use

from one location to another, building caps are likely to offer little in the way of improvements to the basic problems faced by the City of San Diego and the surrounding region. Traffic problems, street capacity, open space availability and use, and environmental impacts of growth are all factors with regionwide implications. Policies that address the specific issues, whether through road improvements, open space acquisition, or sensitive lands protection, have far greater likelihood of being effective than a policy of residential building caps.

More generally, this research contributes to a slowly growing body of evidence on the effectiveness of land use policy as a way of controlling or directing economic trends. In general, it appears that factors such as land availability and the price of housing or industrial space is far more likely to be the result of specific growth patterns (positive or negative) rather than the cause of those patterns. Economic development specialists and growth management advocates alike would be wise to turn their attention towards the more fundamental causes of employment growth or related infrastructure and environmental concerns in trying to develop effective responses to those problems.

Footnotes

1. A forthcoming working paper describes analysis performed at CREUE as part of the San Diego research that examined factors affecting growth rates in basic employment sectors among major high-tech manufacturing metropolitan areas between 1980 and 1985.
2. Because of our method of estimating housing permits, this is a less extreme fluctuation than may actually occur. The estimates reflect responses to demand generated by employment growth, and not to speculative periods or the effects on demand of changing interest rates.
3. Again, because of the present size of the San Diego County housing market, the analysis reported in Landis, Kroll, Griesenbeck, Belzer, Evrengil, Stroshane and Leigh-Preston 1988 found that any additional commuting impacts from spillover and relocation would probably be small compared to established travel patterns.

REFERENCES

- Analysis Research Limited. 1987. A Survey of San Diego Region Residents Concerning Population Growth Issues. San Diego: Prepared for the San Diego Association of Governments.
- Citizens for Limited Growth. 1987a. Quality of Life Initiative. September 27.
- Citizens for Limited Growth. 1987b. Rural Preservation and Traffic Control Initiative. December 24.
- Colburn, George A. 1986. San Diego: Beyond Spit and Polish. From Porter, Douglas R., ed. Growth Management: Keeping on Target?. Washington, D.C.: ULI--the Urban Land Institute, with the Lincoln Institute of Land Policy.
- Dowall, David E. and John Landis. 1981. Land-Use Controls and Housing Costs: An Examination of San Francisco Bay Area Communities. Berkeley: Center for Real Estate and Urban Economics, University of California at Berkeley, Working Paper 81-24.
- Elliott, Michael. 1981. The Impact of Growth Control Regulations on Housing Prices in California. AREUEA Journal 9, 2: 115-133.
- Greater San Diego Chamber of Commerce. 1987. San Diego Office Building Guide 1986/1987.
- Kroll, Cynthia A. 1986a. California Growth Trends--Setting the Stage for the Rest of the Decade. Quarterly Report. Berkeley: Center for Real Estate and Urban Economics, University of California at Berkeley. Third Quarter.
- Kroll, Cynthia A. 1986b. Suburban Squeeze II: Responses to Suburban Employment Growth. Berkeley: Center for Real Estate and Urban Economics, University of California at Berkeley, Working Paper 86-110.
- Kroll, Cynthia A. and Bruce Griesenbeck. 1987. Emerging Growth Issues in Southern California. Quarterly Report. Berkeley: Center for Real Estate and Urban Economics, University of California at Berkeley. Third Quarter.
- Landis, John D., Cynthia A. Kroll, Efza Evrengil and Bruce Griesenbeck. 1988. Estimating the Housing Price Effects of Growth Management Strategies in the City of San Diego. Berkeley: Center for Real Estate and Urban Economics, University of California at Berkeley, Working Paper 88-148.
- Landis, John, Cynthia Kroll, Bruce Griesenbeck, Dena Belzer, Efza Evrengil, Tim Stroshane and Nancey Leigh-Preston. 1988. The Impacts of Residential Growth Controls on San Diego's Housing Market and Employment Base. Berkeley: Center for Real Estate

and Urban Economics, University of California at Berkeley, report prepared for the San Diego Citizens Advisory Committee on Growth and Development and the City of San Diego. May.

Lee, Douglas. 1973. Requiem for Large-Scale Models. Journal of the American Institute of Planners 39, 3: 163-178.

Lillydahl, Jane H. and Larry D. Singell. 1987. The Effects of Growth Management on the Housing Market: A Review of the Theoretical and Empirical Evidence. Journal of Urban Affairs 9, 1: 63-77.

Miller, Thomas I. 1986. Must Growth Restrictions Eliminate Moderate-Priced Housing? Journal of the American Planning Association Summer: 319-325.

Rick, William B. 1987. Growth Management in San Diego. Urban Land. April: 3-5.

Rosen, Kenneth T. and Lawrence F. Katz. 1981. Growth Management and Land-Use Controls: The San Francisco Bay Area Experience. AREUEA Journal 9, 4: 321-344.

Rosen, Kenneth T. and Ruth Shragowitz. 1985. The Proposed Growth Limit on Commercial Construction in San Francisco. Berkeley: Center for Real Estate and Urban Economics, University of California at Berkeley, Working Paper 85-94.

Rubinfeld, Daniel L. 1978. Suburban Employment and Zoning: A General Equilibrium Analysis. Journal of Regional Science 18, 1: 33-44.

SANDAG (San Diego Association of Governments). 1987. Growth Management Activities in the San Diego Region and Southern California. San Diego: Agenda Report No. R-75. July 31.

San Diego Economic Development Corporation. 1987a. Growth Management and the Economy.

San Diego Economic Development Corporation. 1987b. Guide to Industrial/R&D Space: San Diego County 1986-1987.

Stepner, Michael J. 1986. San Diego's System: Is it Working? From Porter, Douglas R., ed. Growth Management: Keeping on Target? Washington, D.C.: ULI--the Urban Land Institute, with the Lincoln Institute of Land Policy.

Zorn, Peter M., David E. Hansen, and Seymour I. Schwartz. Mitigating the Price Effects of Growth Control: A Case Study of Davis, California. Land Economics 62, 1: 46-57.

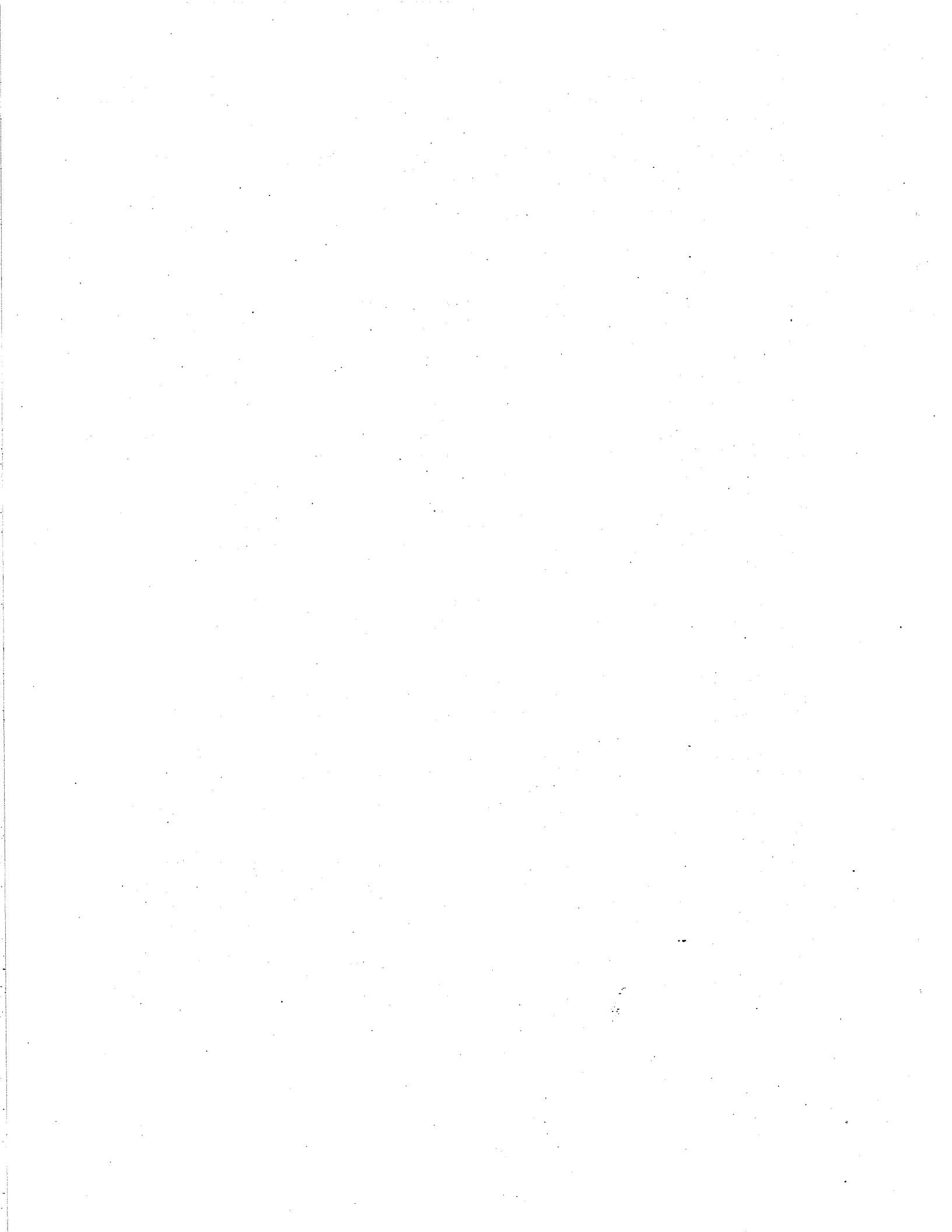

APPENDIX A

DATA SOURCES USED IN THE SAN DIEGO TIME SERIES ANALYSIS

Data for the analysis came primarily from published sources. Some of the data required adjustments to allow for a consistent 21-year time series. The major adjustments made are described here.

Private Employment Data

All of the private employment data used to calibrate the time series models is from the U.S. Census Bureau's annual publication County Business Patterns (CBP). CBP is the one source of employment data for San Diego that was available in an annual series of at least 2 decades (we used the 21 years between 1965 and 1985). In 1972 some Standard Industrial Classification Codes (SIC Codes) were redefined, but this change was generally at a more detailed level (3 and 4-digit SICs) while our analysis relied on broader aggregations of industries (groupings of 2-digit SICs). Analysis with dummy variables did not find the SIC classification changes to be significant; our analysis assumes the broad aggregates defined for the San Diego economy (see Section III of this appendix) contain essentially the same sorts of industries in 1965 as they do in 1985.

United States Employment Forecasts

CBP data was used for historic time series for the United States as well as for San Diego, to keep data sources as consistent as possible. For forecasting purposes, however, growth rates for the relevant U.S. sectors were taken from the U.S. Bureau of Labor Statistics, Industry Forecasts to the Year

2000 (unpublished detailed computer print-outs). These growth rates were applied to the aggregate U.S. sectors created for this study (e.g. high tech manufacturing employment), to produce U.S. forecasts to drive the basic-sector San Diego models.

Public Sector Employment

Public sector employment data for local, state, and federal employees was obtained from the California Employment Development Department's (EDD) Annual Planning Information publication for San Diego County, covering the period 1972-1986. Data for 1987 was provided in preliminary form by John Nowell, the EDD labor market analyst for San Diego County. EDD does not have consistent data for years prior to this period, while CBP does not report government employment. For consistency, EDD's total private sector employment was used as the explanatory variable in calibrating the model, rather than CBP data. Before deciding to incorporate EDD's government employment data for the time series employment models we checked the private employment data against the CBP data. The EDD data was quite close to CBP numbers for total private employment. Only 15 years worth of data are used in the government model.

Population

Time series population data for San Diego County was obtained from the Population Research Unit of the California Department of Finance (DOF). DOF publishes July 1st estimates of population for all California cities and counties, including San Diego. Birth and death statistics were taken from annual publications on California Vital Statistics. These were used,

with DOF population estimates, to calculate net migration. DOF's population estimates appear to be "smoothed out" or linearized between the U.S. decennial censuses so that fluctuations in population growth rates of an area may have been averaged out over the period. Consequently, population changes may not be completely accurate on a yearly basis, while the long-term population change may be quite accurate. This feature of the DOF population estimates may have made our residual estimates of net migration less accurate, contributing to difficulties in modelling net migration into the San Diego region.

Housing Permits

Housing permit data were gathered from two commensurable sources. Security Pacific National Bank published California Construction Trends from 1974 through 1986, and Monthly Report on Building Activity in California from 1969 through 1973. Both publications yielded single family and multi-family housing permits in every California city and county unincorporated areas, along with county-wide totals. We supplemented this series with the Greater San Diego Chamber of Commerce's data on single-family and multi-family permits for the period 1965 to 1968. To assure that the general trends between the Chamber's data and Security Pacific's were commensurable in both magnitude and direction, we compared the succeeding years' data (that is, 1969-85) for each set and found them to be quite similar.

Housing Stock

Our data on San Diego County housing stock came from estimates made by DOF for 1975 through 1985. Earlier years were estimated from building permit activity. An econometric model

relating housing units added to the two previous years of building permits showed new units in any given year to equal one third of permits issued two years previously plus half of permits issued in the past year. Thus, housing stock in 1974 was estimated as 1975 housing stock minus the sum of half of 1974 housing permits and one third of 1973 housing permits. The 1970 housing unit count estimated by this "backtracking" method was very close to the U.S. census count for San Diego housing stock in that year.

Relative Home Sales Prices and Rents

Relative single family home prices were obtained from surveys of home sales prices reported annually by the Greater San Diego Chamber of Commerce. Rental prices were taken from surveys the Chamber of Commerce did for the American Chamber of Commerce Research Association (ACCRA). ACCRA publishes quarterly price data in its Cost of Living Indicators publication going back to 1968. Our time series for rental rates in San Diego covers the period 1968-85. Second and fourth quarter apartment rents were averaged to represent the average annual rent for the San Diego region. The rent data is based on a typical 2 bedroom, 1 bath, 900 square foot apartment.

Per Capita Income

Per capita income data for 1965 through 1984 was obtained from DOF. The data is adjusted to constant dollars (1967 base) using the U.S. consumer price index.

Interest Rates

Interest rate data for the modelling period was obtained

from Citicorp's Citibase data base. The only time series available for the full period was the secondary market yield on FHA insured loans. Comparison of this variable with conventional home mortgage rates for more recent years showed a close correlation between the two.

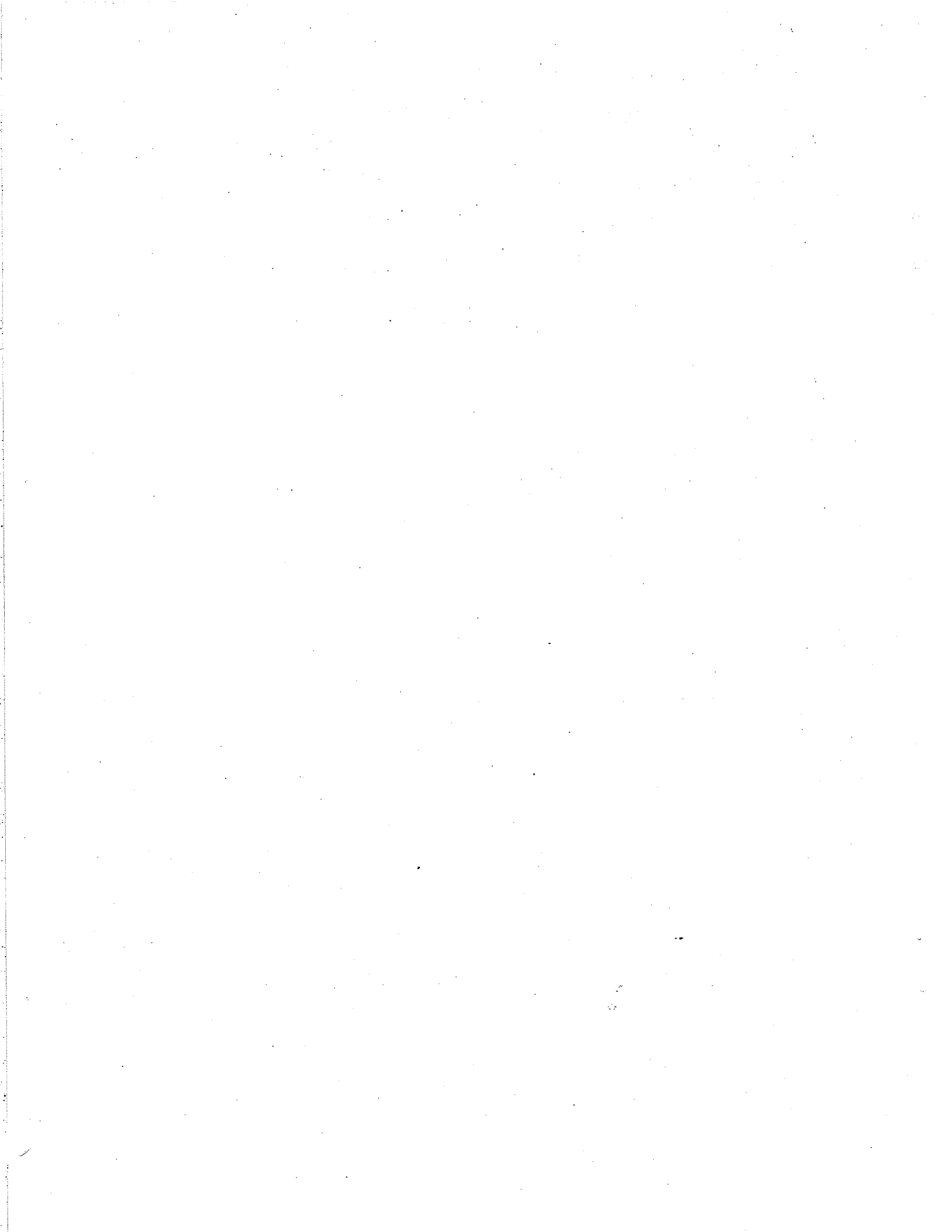

APPENDIX B

ALTERNATIVE POPULATION AND HOUSING PERMIT ESTIMATES

Two key issues in doing an analysis of housing cap impacts are how caps are likely to affect 1) housing production and 2) population growth. Thus, it is disturbing that these two factors give quite unsatisfactory results in econometric modeling. This appendix describes some alternative models to those presented in the text and discusses the sensitivity of results to variations in model structure and in multiplier levels used.

Population Models

Annual population figures available at the city and county level in California are based on estimates by the California Department of Finance (DOF). New housing units are an element used in making the population estimates. Thus, using housing permits as an element in the econometric model would simply be to reproduce the DOF estimating technique, rather than to identify the underlying causal factors in population growth. Instead, models with several different types of explanatory variables were tested. The explanatory variables tested included:

MODEL I: Basic employment levels (R-Squared 0.974, Durbin-Watson 1.063). This is the model reported in the text.

MODEL II: Basic employment levels, the ratio of population to employment (R-Squared .975, Durbin-Watson 1.005).

MODEL III: Last year's population (R-Squared .998, Durbin-Watson, 1.502).

MODEL IV: Last year's population, the rental CPI (R-Squared .998, Durbin-Watson 2.1).

At first glance, Model IV appears very promising. However, because the model has no labor force demand component, the forecasts it produces are completely unsupportable. For example, because the rental CPI grows much more slowly with slow economic growth than under high growth, this model forecasts a total population increase from 1985 to 1995 of 18.5 percent under high growth and 21.1 percent under low growth. Model III also has a somewhat better fit than Models I and II, but it is completely insensitive to all economic factors, which also seems quite unlikely. Models I and II have similar R-Squared levels and equally poor Durbin-Watson statistics. The forecasts produced by Model II are slightly lower than those produced by Model I (a 10-year population increase of 22 percent under Model II, compared to 26 percent under Model I). Model I is used in the report as a compromise, showing the impacts of basic employment on population growth, but also allowing population to grow at a level that may include some growth unrelated to employment opportunities.

The critical question with all of these models is how do they fare in showing the impacts of housing stock restrictions on population growth. All four models found very small population growth impacts from restricted housing production. The least sensitive model, of course, is Model IV, which shows no impacts, while the most sensitive is Model III, where population growth levels dropped from 18.5 percent to 17.8 percent over the 10 year period. Thus, the impacts of caps are consistently small under each of the population growth models calibrated.

Varying the Housing Multiplier

Time series econometric models of housing permit activity in San Diego County give R-Squared levels ranging from less than 0.4 to at best 0.75. Even the best of these models tended to be either implausible or explosive in predicting building permit levels. For example, a model with relatively good explanatory power, and with an acceptable Durbin-Watson statistic might still predict building permit levels to proceed at 3 or 4 times the number of new jobs added (totally contrary to historic experience).

The multiplier approach to calculating building permit levels has the advantage of producing believable levels of building permit activity and of eliminating the need to forecast future interest rates. However, the size of the multiplier can vary considerably over time, depending on other aspects of the economy, and especially on interest rate levels. If the multiplier is as low as 1.75, then the housing price impacts are somewhat lower than those reported in the text. Housing prices might be raised by only 1.5 percent under caps, if unconstrained housing production would be at the lower 1.75 multiplier level. In contrast, if the multiplier were 2.25 (as might occur if interest rates are low during much of the period), then the price differential between capped and uncapped growth would be close to 3 percent countywide.

Summary

Clearly, the limitations in modeling these two aspects of the economy make the results of the analysis indeterminate. We

cannot say that price effects will be 2 percent, not 1 percent or 3 percent. However, in a more general sense, the results are quite consistent from one form of the model to another. Because of the existing size of the San Diego economy and housing base, the effects of housing caps on population levels will be very small, at least over the first decade. The effects on housing prices may also be small when averaged over the county, but the effects on specific parts of the city and specific consumer groups are likely to be significant.