

Lawrence Berkeley National Laboratory

Recent Work

Title

DESIGN OF THE CRYOPUMPING VACUUM SYSTEM FOR ESCAR

Permalink

<https://escholarship.org/uc/item/6x2986c4>

Author

Wolgast, Richard C.

Publication Date

1975-03-01

To be presented at the 1975 Particle
Accelerator Conference, Washington, DC,
March 12-14, 1975

LBL-3372
c.2

DESIGN OF THE CRYOPUMPING VACUUM SYSTEM FOR ESCAR

Richard C. Wolgast

March 1975

Prepared for the U. S. Atomic Energy Commission
under Contract W-7405-ENG-48

TWO-WEEK LOAN COPY

*This is a Library Circulating Copy
which may be borrowed for two weeks.
For a personal retention copy, call
Tech. Info. Division, Ext. 5545*

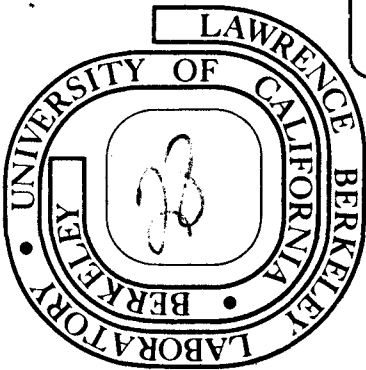

LBL-3372
c.2

DISCLAIMER

This document was prepared as an account of work sponsored by the United States Government. While this document is believed to contain correct information, neither the United States Government nor any agency thereof, nor the Regents of the University of California, nor any of their employees, makes any warranty, express or implied, or assumes any legal responsibility for the accuracy, completeness, or usefulness of any information, apparatus, product, or process disclosed, or represents that its use would not infringe privately owned rights. Reference herein to any specific commercial product, process, or service by its trade name, trademark, manufacturer, or otherwise, does not necessarily constitute or imply its endorsement, recommendation, or favoring by the United States Government or any agency thereof, or the Regents of the University of California. The views and opinions of authors expressed herein do not necessarily state or reflect those of the United States Government or any agency thereof or the Regents of the University of California.

DESIGN OF THE CRYOPUMPING VACUUM SYSTEM FOR ESCAR*

Richard C. Wolgast
Lawrence Berkeley Laboratory
University of California
Berkeley, California 94720

Summary

ESCAR is an experimental superconducting accelerating and storage ring for protons.

Scattering collisions with residual gas degrades the quality of proton beams that are stored for long time periods. The loss of quality will be small if the average gas density in the path of the beam is kept less than about 10^6 molecules per cm^3 , depending upon the gas species. This density corresponds to a room temperature pressure for nitrogen-like gases of 3×10^{-11} Torr. We plan to achieve this vacuum goal in the ESCAR ring by distributed cryopumping at 4.5°K , the operating temperature of the superconducting magnets. In the magnet sections the cold bore of the magnet will provide the condensing surface. In the straight sections, 4.5°K beam tube or distributed cryopumps will be provided consistent with the function of the particular section. The large cryosurface area provides effective pumping capacity for H_2 by utilizing sub-monolayer adsorption. The surfaces can be degassed of H_2 by a temperature rise to 15°K . The cycle can be accomplished during routine maintenance periods. We expect the interval between the degassing of the magnet quadrants to be of the order of months. Because of the experimental nature of ESCAR, sector valves will be provided to permit the isolation of each straight section from the ring to allow ready accessibility for equipment testing and modification. Each section will have a roughing and conditioning pumping station. We plan to use valved, bare surface cryopumps, augmented by cryosorption on CO_2 , to finish roughing and for pumping during the H_2 degas cycles.

Introduction

The ESCAR ring consists of four magnet quadrants containing the superconducting bend magnets and quadrupoles separated by straight sections. The ring circumference is 96 m and each straight section is 6 m long. The clear diameter of the bend magnet bore is 14cm. Seventy-five percent (75%) of the ring will be enclosed in the magnet cryostats, and most of this length will operate at 4.5°K with short lengths at 80°K . These low temperatures create a friendly vacuum environment in which the vapor pressures of all gases except H_2 and He are less than 10^{-16} Torr and outgassing and permeation rates fall to negligible values.

Beam-Gas-Wall Desorption

The proton beam may disturb this environment. Beam protons collide with residual gas molecules, some of the molecules become ionized and are driven toward the wall by the electrostatic field of the beam. When the ion strikes the wall it can desorb as many as $50,000^1$ molecules depending on the energy of the ion and the amount and kind of gases adhering to the wall. If the number of molecules desorbed exceeds the number of ions trapped there will be a rise in pressure. The increased pressure will be a stable value if the pumping speed is greater than the desorption rate. If the pumping speed is less than the desorption rate there will be an unstable pressure rise. This pressure runaway has been experienced on the ISR at CERN and has been thoroughly investigated.⁹ During the last year or so the analysis has been applied to prospective cold bore accelerators,^{2,3,4} and is summarized below.

The removal rate of the gas molecules by distrib-

uted cryopumping is given by:

$$n \cdot \alpha A S_m (1 - \sqrt{T_g/T_s} P_{eq}/P_o)$$

where n = molecular density of gas in the tube, and the remaining terms express the pumping speed of a condensing surface, where

- α = condensation coefficient
- A = total cryopump area
- S_m = theoretical maximum pumping speed of a unit area (= mean molecular velocity/4)
- P_{eq} = vapor pressure of the gas in equilibrium with a surface at temperature T_s
- P = pressure of the gas at temperature T_g .

The rate of desorption is given by: $N v \sigma d$, where

- N = number of beam particles
- v = velocity of beam particles
- σ = cross section for beam-gas ion production
- d = number of ions desorbed per impinging ion.

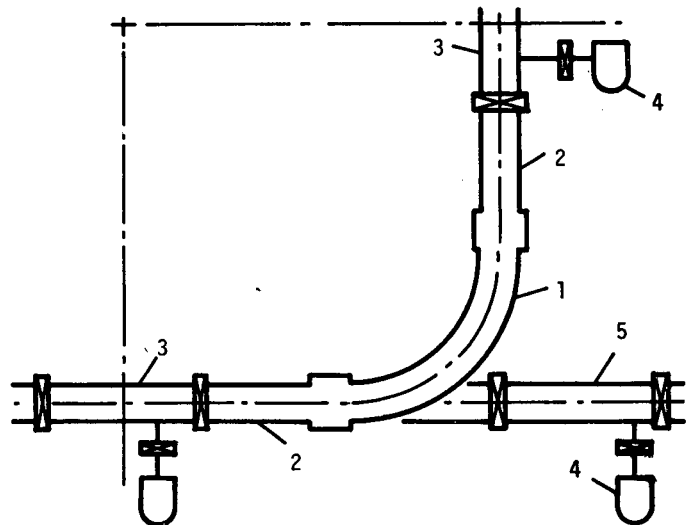

Fig. 1. Quadrant of vacuum system: 1. bend magnet bore, 2. quad bore, 3. straight section, 4. cryogenic cond. pump, 5. injection line transition pump.

There can be an equilibrium if the removal rate is equal to the production rate:

$$n \alpha A S_m (1 - \sqrt{T_g/T_s} P_{eq}/P_o) = N v \sigma n d \quad (1)$$

Assuming $T_g = T_s$ and transposing, gives the equation shown in Fig. 2.

The critical condition for pressure runaway occurs when the denominator becomes zero or:

$$\alpha A S_m = N v \sigma d \quad (2)$$

This expression is equivalent to that given by Eq. (1) (Halama³) if his second term, representing auxiliary pumping at intervals is omitted. (We see the critical condition is independent of the initial pressure.) The equation in Fig. 2 is plotted with d as the abscissa, using values appropriate to ESCAR, and assuming that the predominant gas is hydrogen:

$\alpha = 1$
 $A = 4.2 \times 10^5 \text{ cm}^2$
 $S_m = 5400 \text{ cm}^3/\text{cm}^2 \text{ s}$
 $N = 5 \times 10^{12} \text{ protons}$
 $v = c = 3 \times 10^{10} \text{ cm/s}$
 $\sigma = 5 \times 10^{-19} \text{ cm}^2 \text{ for H}_2$

σ is a function of proton beam energy and should be more definitely determined in the ESCAR energy range from 50 MeV to 4 GeV. d is a function of the energy of the impinging ion which depends on the beam current and its bunching characteristics, and of the amount of H_2 adsorbed on the surface. Our best estimate of d is about 5000, which would give a pressure rise of 5%. If H_2 coverage is kept lower than one monolayer, d cannot exceed 10,000, which would give a pressure rise of 40%. These values are sufficiently below the critical value of 34,000 for us to try the simple cold bore design for ESCAR.

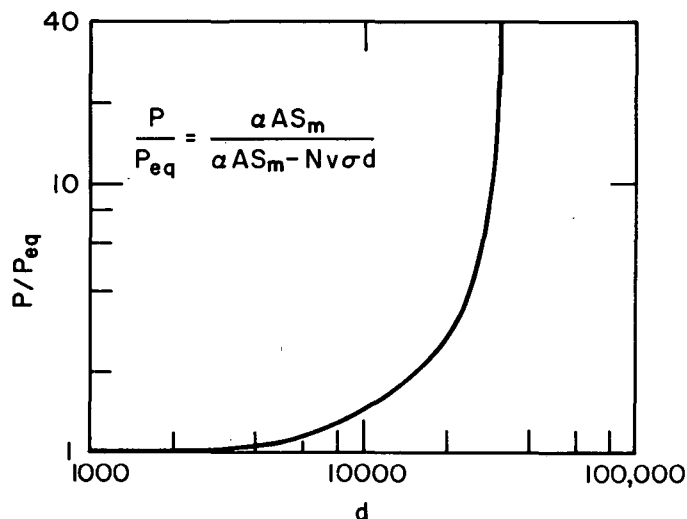

Fig. 2. Graph of P/P_{eq} , ratio of pressure in the presence of beam to the P_{eq} equilibrium pressure without beam, vs d , the number of gas molecules desorbed per incident ion; for a cryopumping bore tube.

For higher current accelerators it may be necessary to protect the cryopumping surface from impinging ions. This can be accomplished by a baffle such as the chevron shown in Fig. 3. In the presence of the high pumping speed the baffle will be quickly cleared of adsorbed gas and will provide low desorption rates. Such a baffle could be added to ESCAR if it proves necessary.

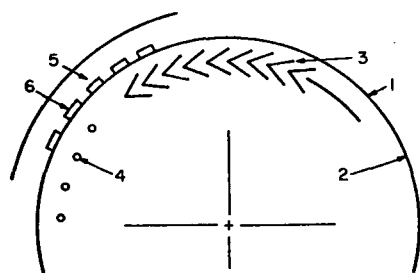

Fig. 3. Alternative magnet bore cross sections, 1. stainless steel bore tube, 2. plating to provide desired beam impedance, 3. chevron baffle, 4. wire grid alternative, 5. epoxy-fiberglass, 6. prospective liquid He cooling channels.

A calculation was made with John Chubb's Monte-Carlo computer program⁵ (named CHUBBY at LBL) for the situation where a molecule is desorbed from a tube wall and bounces back and forth until it is pumped away, in case 1) by condensing on the cryopumping bore tube; or case 2) by being captured in one of the pumps located at intervals L along the beam tube of diameter D . The pump in case 2) was represented by a length of tube wall of area equal to the tube cross section with a capture

coefficient of 0.3. CHUBBY calculated the total path length of each randomly desorbed molecule through a beam space which occupies 80% of the tube diameter. The program was run for $L/D = 10$ and three values of condensation coefficient. The ratio of the total path lengths (for the same number of desorbed molecules in each case) are:

Condensation coefficient	Total path length ratio: warm bore/cold bore
.05	7.55
.2	30.8
.8	120.8

The results were then corrected for the effect of gas temperature and analytically extended to $L/D = 40$. Molecular velocity varies as $T^{1/2}$.

Cond. coef.	Assumed gas temp. ($^{\circ}\text{K}$)	Total residence time ratio: warm bore/cold bore	
		$L/D = 10$	$L/D = 40$
.05	80	4.23	26.
.2	80	17.5	109.
.8	160	24.7	154.
.8	4.5	15.8	98.

Since the residence time is inversely proportional to the rate of removal of the desorbed molecules, the numbers of the last two columns express the improvement in pumping speed and critical beam current that can be expected from distributed pumping, assuming other factors are kept equal.

The condensation coefficients in the calculation can be related to practical designs. An effective coefficient of .05 can represent a baffled cold bore with 15% of the circumference chevron baffles (or the equivalent) with a capture coefficient of 1/3 and the rest of the circumference a solid shield; a coefficient of 0.2 a baffle 60% chevron; and the coefficient of 0.8 the unbaffled cold bore. It is worth noting that the baffled cold bore can be better than unbaffled bore on the basis of pumping speed alone, a result also noted by Benvenuti.⁴

Image and Eddy Currents

Another possible disturbance to the vacuum environment by the beam is the image current accompanying a bunched beam. This is a surface current of high frequency which flows in the longitudinal direction. The wall must provide a minimum impedance to provide longitudinal stability and to prevent excessive RF heating of the walls. The currents fall in the range of temperature and frequency of the anomalous skin depth. Eddy currents from the rising magnetic field also flow in the longitudinal direction and require a wall of low conductivity to limit magnetic field distortion and excessive eddy current heating. Considerations by the RF Group indicate that a thin coating of one of the good conductors such as Al, Au, or Cu, for which the electron mean free path at low temperature is much greater than the coating thickness, should satisfy both the pulsed field and image current heating requirements. Therefore we plan to investigate experimentally the properties of the ESCAR magnet bore tube of 0.5 mm (.020 in.) stainless steel coated internally with thicknesses in the range of 1000 Å of these metals to find a good procedure and material combination. The resulting image current heating from the completely bunched (1 m long) beam of 5×10^{12} particles is expected to be 2-3 W/m due to the anomalous skin effect. The eddy current heating in the stainless will be 1.3 W/m; and in the coating the eddy current heating will be much less than the "classical" value of 1 to 1.5 W/m as would be obtained by assigning

the bulk conductivity to the thin film, because the conductivity of the 1000 A layer at dc is expected to be a few percent of the bulk value. Timewise the eddy current heating occurs during acceleration and the image current heating occurs during storage and strong bunching. Careful heat transfer design will be required so that the transient temperature rises will be small enough not to disturb the cryopumping. Liquid helium cooling channels may be provided on the outside of the bore tube, or alternatively a longitudinal grid of wires may be inserted in the bore to carry the image currents (Fig. 3). They could be capacitively connected at one end of the ring quadrant to interrupt the eddy current circuit and could be allowed to float in temperature.

The Straight Sections

Distributed 4.5°K cryopumping will be designed for each straight section with adequate capacity to handle the section's gas load and prevent excessive gas flow into the adjoining magnet quadrants. The cryopanel will be supplied by a separate series circuit of liquid helium from the main refrigerator and can be cooled before the magnets.⁶ A warm helium gas circuit will be provided to speed warm-up. Room temperature outgassing areas and the number of warm to cold transitions will be kept to a minimum, consistent with required functions. Each warm to cold transition in the 14 cm diam beam line could cause a radiant heat load as large as 8 W from room temperature to 4.5°K, with an accompanying degradation of the cryopumping, and a conductive heat load through the thermal isolation bellows of 0.3 W from 80°K to 4.5°K.

If certain components, such as the RF gaps or the inflector, show persistent high rates of H₂ outgassing, cryosorption pumping may be added.

The experimental straight section will provide access for accelerator development and diagnostic equipment. Ports will be provided at each end of the section and at the beam focal point at the center. There will be two, 2m, lengths of 4.5°K beam tube between the access points. The 80°K shield will be extended through the access ports and the equipment will operate at 80°K wherever practicable.

A design study for this section is shown in Fig. 4.

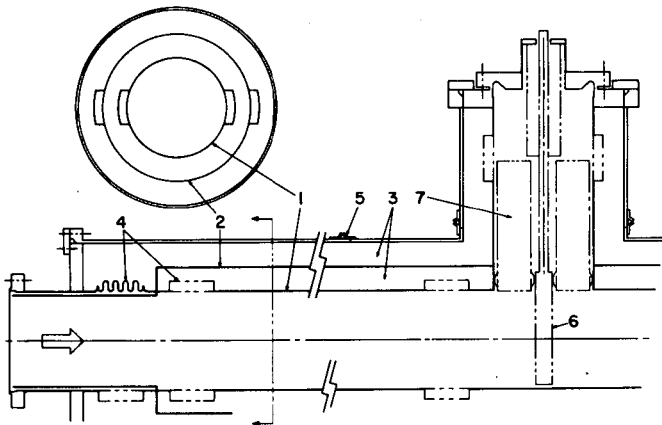

Fig. 4. Experimental straight section: 1. liquid helium cooled bore tube, 2. liquid nitrogen cooled shield, 3. insulating vacuum, 4. bellows for thermal isolation, 5. joints in the removable insulating vacuum jacket, 6. retractable beam probe, 7. thermal and RF shielding.

The separate insulating vacuum will permit the use of multilayer thermal insulation. The insulating jacket is elastomer sealed and may be removed to localize leaks.

The injection straight section will contain a septum magnet, electrostatic inflector, two access ports for beam probes, and three pulsed bump magnets to steer orbiting beam around the inflector. The bump magnets will be warm bore magnets. A preliminary layout of this section is described by Tanabe.⁷

The RF section will include a pair of cavities borrowed from Brookhaven for first harmonic acceleration and a new cavity for continuing the acceleration on the 11th harmonic. We plan to rebuild the BNL cavities to handle higher voltages and to enlarge the bore to accept tubular cryopanel. All the vacuum wall except for a short length near the RF gap will be at cryogenic temperatures. This approach seems desirable because there is no free length available for external pumping. Any shortening of the cavities causes a sharp increase in RF power requirements. The new cavity will have integral cryopanel and a port for the conditioning pump.

The fourth straight section will be used for beam extraction and the strong-bunching cavities. Specific design studies have not yet been made.

Injection Line Transition Pump

Normal economical operation of the present injection line results in pressures around 10⁻⁶ Torr. At the point where the line approaches the ESCAR ring the pressure must be attenuated by a factor of 10⁻⁵. To do this in any reasonable length requires that the line-of-sight molecular flow be intercepted. We are designing to do this by running a 4.5°K bore tube through the last injection line bend magnet. This flow situation was calculated by the CHUBBY program, which handles axisymmetric cases. The geometry of the bent tube was modeled by the reflecting central body which intercepts the line-of-sight molecules, Fig. 5. The results

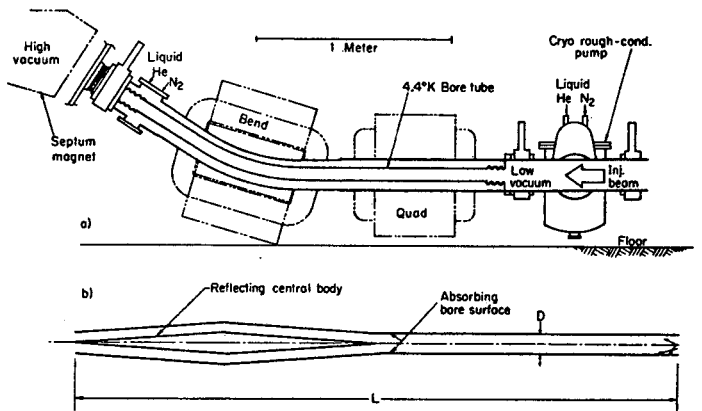

Fig. 5. a) Injection line transition cryopump. b) Mathematical model (axi-symmetric), of the transition pump, used in CHUBBY computer program. L/D = 15.

describe a nearly exponential pressure decay of the form $P = P_0 \exp(-k x/D)$ where x is the distance down the tube, in the straight section of the tube; and then a leveling of the pressure in the region where the line-of-sight molecules are scattered. For values of condensation coefficient of 0.2 and 0.4, the values of k were 0.74 and 0.9 respectively. From these results we were able to calculate that an L/D = 22 would give the required attenuation.

CO₂ cryosorption will be used to provide convenient time intervals between degas cycles. Mild routine bake-out facility will be provided for the transition cryopump.

Roughing, Finishing, and Conditioning

The system will be pumped from atmosphere to 0.1 Torr by a liquid N₂ trapped mechanical pump. The pressure will not be allowed to fall below this value during roughing, by the automatic addition of boil-off N₂ gas, to prevent oil backstreaming. The N₂ gas flow will flush atmospheric He from the system. Pumping from 0.1 Torr to < 10⁻⁶ Torr will be accomplished by the 4.5°K cryogenic pump, Fig. 6. At the beginning of this pumping phase the pump will be throttled to keep the pressure inside the pump less than about 5 x 10⁻³ Torr. The nitrogen reservoir will be designed to withstand 8 atm so the shield temperature can be held at 100°K to prevent CO₂ from condensing on the shield. This pump will also be used as the conditioning pump during the H₂ degas cycles, using a CO₂ deposit to adsorb the H₂.⁸ We expect to use the pump only for intermittent operation so it was not designed with a He gas cooled shield to reduce heat leak. A well-trapped diffusion pump could be used for finishing and conditioning. We want to try the cryopump because of its inherent safety advantage and the availability of liquid helium.

Bakeout

We do not expect that routine high temperature baking will be required, and it will not be possible nor needed in the magnet sections, which operate entirely at cryogenic temperatures. The straight sections could be baked to high temperature, if necessary, by heated helium gas flow in the channels normally used for cooling, and by external mantles applied to the single wall areas. All the materials in the ring vacuum will be bakeable to 350°C, and will be cleaned and baked before installation. Particular attention will be given to critical components which will be at ambient temperature during operation. The degree of bakeout required after initial installation will be investigated in our test program.

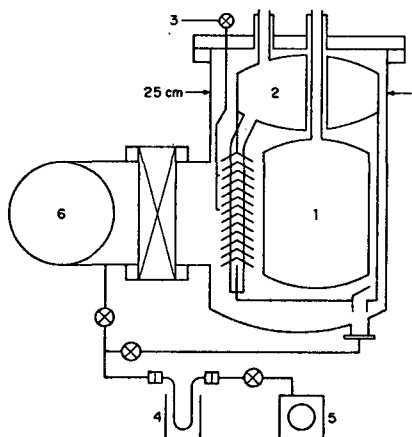

Fig. 6. Roughing, finishing, and conditioning pumping system: 1. liquid helium, 2. liquid nitrogen, 3. CO₂ inlet manifold, 4. liquid nitrogen U trap, 5. mechanical pump, 6. ESCAR ring vacuum.

Leak Detection and Helium

Four leak detector sensing heads will be permanently mounted around the ring. They will be provided with improved electronics according to plans developed by Milleron and Grazier to substantially increase the sensitivity. The new electronics will permit scanning over the low molecular mass range. A prototype is being completed for testing.

No guard vacuum in the magnet bore is planned for ESCAR. This approach can be successful if leak checking during fabrication is performed at the operating condi-

tions of temperature and stress with maximum sensitivity. Although the specific cryosorption capacity for He is small, a substantial number of leaks below the detectable limit can be pumped effectively, because of the large surface area. The permanently mounted detectors will be used to monitor the He level in the ring.

Vacuum Testing Program

A test program has been started to accompany the design studies. A test chamber 1.3 m long by 0.5 m diam with a full length of liquid N₂, and liquid He cryopanel has been completed.

Acknowledgement

A special acknowledgment is due Norman Milleron for his continuing consultations and guidance.

References

- * Work performed under the auspices of the U. S. Atomic Energy Commission.
- 1. S. K. Erents and G. M. McCracken, Desorption of Solid Hydrogen by Energetic Protons, Deuterons, and Electrons, *J. Appl. Physics*, **44** (7) (July 1973).
- 2. J. R. J. Bennett, Hot or Cold Bore for a Superconducting EPIC Ring?, Rutherford Lab internal report, EPIC/MC/42 (Jan. 1974) and private letter, May 1974.
- 3. H. J. Halama and J. W. Bittner, Some Remarks on Cold Bore Vacuum Systems, Brookhaven National Lab., Accelerator Department Informal Report AADD 74-3 (May 1974).
- 4. C. Benvenuti, Vacuum System for Proton Storage Rings Equipped with Superconducting Magnets, FERMI-LAB-74/109 (Dec. 1974).
- 5. J. N. Chubb, A Monte Carlo Computer Programme for Analysis of Molecular Gas Flow, United Kingdom Atomic Energy Authority CLM-R54, H. M. Stationery Office (1966).
- 6. R. A. Byrns, M. A. Green, The ESCAR Refrigerator System, Paper K-6, Particle Accelerator Conf., Washington, D. C. (March 1975).
- 7. J. Tanabe, J. Staples, R. Yourd, Design of the ESCAR Injection Beam Line, Paper I-26, Particle Accelerator Conf., Washington, D. C. (March 1975).
- 8. K. Becker, et al., Cryopumping of Hydrogen by Adsorption on Condensed Gases, *Proc. of the 4th Int. Cryo. Engr. Conf.*, Eindhoven, p. 319 (May 1972).
- 9. O. Gröbner and R. S. Calder, Beam Induced Gas Desorption in the CERN Intersecting Storage Rings, *IEEE Trans. on Nucl. Sci.*, **NS-20** (3) (June 1973).
- 10. Superconducting Accelerator MINI-PROJECT, Lawrence Berkeley Laboratory (Oct. 1973).

LEGAL NOTICE

This report was prepared as an account of work sponsored by the United States Government. Neither the United States nor the United States Atomic Energy Commission, nor any of their employees, nor any of their contractors, subcontractors, or their employees, makes any warranty, express or implied, or assumes any legal liability or responsibility for the accuracy, completeness or usefulness of any information, apparatus, product or process disclosed, or represents that its use would not infringe privately owned rights.

TECHNICAL INFORMATION DIVISION
LAWRENCE BERKELEY LABORATORY
UNIVERSITY OF CALIFORNIA
BERKELEY, CALIFORNIA 94720