

UC Irvine

UC Irvine Previously Published Works

Title

Multifrequency cross-correlation phase fluorometer using synchrotron radiation

Permalink

<https://escholarship.org/uc/item/6z5671pq>

Journal

Review of Scientific Instruments, 55(4)

ISSN

0034-6748

Authors

Gratton, E
Jameson, DM
Rosato, N
[et al.](#)

Publication Date

1984-04-01

DOI

10.1063/1.1137777

Copyright Information

This work is made available under the terms of a Creative Commons Attribution License, available at <https://creativecommons.org/licenses/by/4.0/>

Peer reviewed

Multifrequency cross-correlation phase fluorometer using synchrotron radiation

E. Gratton

Department of Physics, University of Illinois at Urbana-Champaign, Urbana, Illinois 61801

D. M. Jameson

Department of Pharmacology, University of Texas Health Science Center at Dallas, Dallas, Texas 75235

N. Rosato

Laboratorio di Biofisica e Biologia Molecolare, Pisa, Italy

G. Weber

Department of Biochemistry, University of Illinois at Urbana-Champaign, Urbana, Illinois 61801

(Received 28 October 1983; accepted for publication 22 November 1983)

The construction and operation of a cross-correlation phase and modulation fluorometer using the synchrotron radiation facility at the ADONE-Frascati electron storage ring is described. In the frequency domain the high repetition rate pulsed source gives a large series of equally spaced harmonic frequencies. Use of cross-correlation techniques in conjunction with such a light source permits one to isolate one harmonic frequency from the adjacent frequencies with high precision. The cross-correlation frequency required for the analysis of the phase delay and modulation ratio is obtained using two coupled frequency synthesizers, one of which drives the radio-frequency cavity of the storage ring and the other which modulates the response of the photomultipliers used for the signal detection. The accuracy, reproducibility, and sensitivity of the instrumentation have been determined on a number of systems and are reported.

PACS numbers: 07.65.Eh,

INTRODUCTION

Time-resolved fluorescence emission is one of the basic methodologies used to study spectroscopic properties of excited molecules. A pulsed light source as provided by synchrotron radiation is particularly appropriate for excitation because of the possibility of continuously varying the wavelength range, and because of the short duration and high repetition rate of the pulse. Generally, the fluorescence emission after a pulse excitation is measured in the time domain using the popular technique of time-correlated single-photon counting (SPC). Phase fluorometry, however, can also be used in conjunction with a high repetition rate pulsed light source with the attendant advantages of the harmonic method. These advantages include the high accuracy of the lifetime determination, the ease of measuring subnanosecond lifetimes, and the rapidity of data collection.

Conventional phase fluorometers use a high-intensity arc lamp or a continuous-wave laser.¹⁻⁶ The intensity of the continuous light source is generally modulated by an acousto-optic modulator or electro-optic device. The frequency of the light modulation ranges from 1 to 200 MHz depending upon the particular experimental arrangement used. In the past the main criticism concerning phase fluorometry was that multiexponential or nonexponential decays could not be analyzed. This criticism is valid only if phase data at a single-modulation frequency is considered. If a wide set of modulation frequencies are available, heterogeneous emissions can, in fact, be accurately analyzed; for a recent review on the principles and applications of multifrequency phase fluorometry, see Jameson *et al.*³

I. PHASE FLUOROMETRY

The theory of the phase fluorometer was given in detail by Dushinsky⁷ who demonstrated that a fluorescent species can be illuminated by light modulated at circular frequency ω according to the expression

$$E(t) = E_0[1 + M_E \sin(\omega t)], \quad (1)$$

where M_E is the modulation factor corresponding to the ratio of the ac to the dc part of the signal. When the fluorescence is due to a population decaying according to a single exponential $e^{-t/\tau}$, where τ is the lifetime, then

$$F(t) = F_0[1 + M_F \sin(\omega t + \phi)], \quad (2)$$

and

$$\tan \phi = \omega \tau^p, \quad (3a)$$

$$\cos \phi = M = [1 + (\omega \tau^p)^2]^{-1/2}. \quad (3b)$$

In a typical phase and modulation measurement, the phase delay and modulation ratio for scattered light (from glycogen or a suspension of latex particles) and the fluorescence are obtained relative to a reference photomultiplier or internal reference signal (Fig. 1). The absolute phase delay of the fluorescence ϕ is then given as

$$\phi = (\phi_R - \phi_F) - (\phi_R - \phi_S), \quad (4)$$

where ϕ_R represents the phase of the internal electronic reference signal (or the signal from the reference photomultiplier) and ϕ_F and ϕ_S represent the measured phase readings for the fluorescent and scattered signals, respectively. The modulation of the fluorescence M is defined as

$$M = (\text{ac/dc})_F / (\text{ac/dc})_S, \quad (5)$$

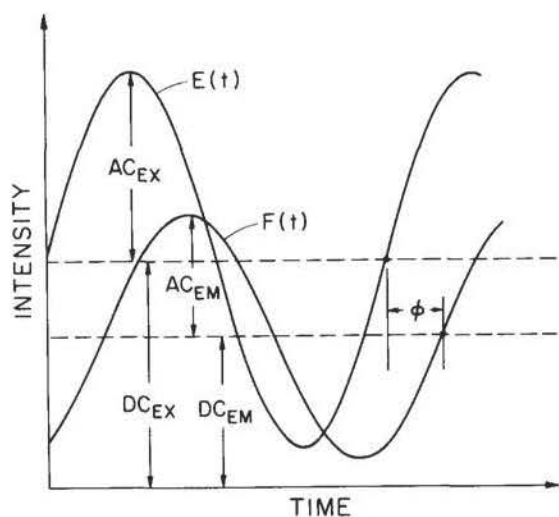

FIG. 1. Schematic representation of the excitation $E(t)$ and fluorescence $F(t)$ waveforms. Fluorescence is delayed by an angle ϕ and demodulated with respect to the excitation.

where the suffixes F and S refer to fluorescence and scattering and the ac and dc terms refer to the alternating and direct current contributions to the signal.

The relationship for the phase angle ϕ and square amplitude M^2 observed for a mixture of sinusoidally modulated components of phases ϕ_1 , modulations M_1 , and fractional intensities f_1 are given by

$$\tan \phi = \left(\sum f_1 M_1 \sin \phi_1 \right) / \left(\sum f_1 M_1 \cos \phi_1 \right), \quad (6a)$$

$$M^2 = \left(\sum f_1 M_1 \sin \phi_1 \right)^2 + \left(\sum f_1 M_1 \cos \phi_1 \right)^2. \quad (6b)$$

A heterogeneous emitting population, in the absence of excited-state reactions will display an apparent lifetime by phase τ^P , which is shorter than the apparent lifetime by modulation τ^M . Moreover, the higher the modulation frequency the shorter will be these measured lifetimes. Various approaches for obtaining the component lifetimes and fractional contributions have been recently reviewed.³

II. PHASE FLUOROMETRY AND SYNCHROTRON RADIATION (SR)

A. General

Gratton and Lopez-Delgado⁸ suggested that a high repetition rate pulsed light source could be employed for multifrequency phase fluorometry instead of a sinusoidally modulated source. The advantage of using a high repetition rate pulsed light source consists of having a large number of modulation frequencies contemporaneously. A typical high repetition pulsed light source is the synchrotron radiation emitted in synchrotrons and storage rings. Consider the time characteristic of the radiation emitted by a storage ring such as the ADONE facility in Frascati. Electrons travel in bunches rather than being dispersed along the orbit and, when the ring is operating in the single-bunch mode, the interval between two pulses is 346 ns. This interval depends

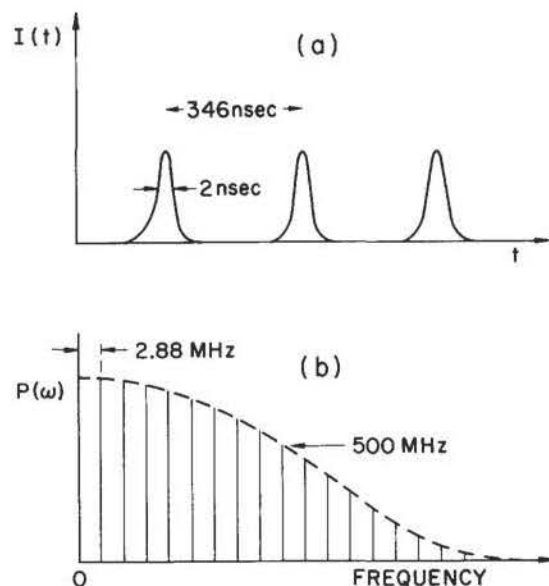

FIG. 2. (a) Schematic representation of the light pulses emitted by the storage ring operating in the single-bunch mode. (b) The power spectrum of the pulse train shown in (a).

on the diameter of the ring and on the energy of the electrons. The shape of the light pulse is approximately Gaussian with a half-width of about 2 ns [Fig. 2(a)]. The corresponding frequency transform consists of a set of harmonic frequencies 2.886167 MHz apart. This frequency set (a comb function) has a Gaussian envelope with a half-width of 500 MHz [the inverse of 2 ns; Fig. 2(b)]. This source is ideal for multifrequency phase fluorometry. The major problem is selecting a particular harmonic frequency while rejecting adjacent frequency components. Cross-correlation methods provide a simple yet powerful technique for selecting a single-harmonic frequency; this technique will be discussed in detail in Sec. II C.

Some preliminary applications of phase techniques in conjunction with synchrotron radiation have been described.^{9,10} In these reports, however, only one or two harmonic frequencies were employed and the powerful cross-correlation technique was not utilized.

Using synchrotron radiation a continuously variable wavelength range is available. The intensity in the near-ultraviolet region of the spectrum is comparable to or greater than that from conventional arc lamps. Another interesting characteristic of synchrotron radiation is that all wavelengths are emitted simultaneously. This property can form the basis of a direct differential measurement on emission resulting from excitation at different wavelengths.

B. Consideration of the signal available at different harmonics

As shown in Fig. 2(b) the intensity of the component at zero frequency (the average value) has approximately the same intensity as the component at 2.88 MHz. The intensity of the next component decreases only slightly while by 500 MHz, the intensity has dropped twofold. The dc component represents the average light intensity. All the photons emitted contribute to this component and the measurement of

the average light intensity is, of course, performed using the full light intensity. By the same argument all photons contribute to the first harmonic frequency, since the intensity of the first harmonic is approximately the same as that of the dc component. Again, the measurement at the n th harmonic is performed using the full light intensity. (In the time domain this situation is equivalent to considering the light pulse as being composed of the sum of all its photons, each photon in the pulse contributing to the pulse shape.) To summarize, in multifrequency measurements the average signal measured at the n th harmonic frequency has approximately the same intensity as the complete fluorescence signal, the sensitivity being the same at all frequencies.

C. Application of the cross-correlation technique to synchrotron radiation

A great improvement in phase fluorometry was the introduction of cross-correlation techniques, as described in detail by Spencer and Weber.¹ The advantage of using cross-correlation resides mainly in the high sensitivity, low noise, and extremely high accuracy in the determination of the phase delay and modulation ratio.

For sinusoidal excitation the emitted light intensity can be described by the following function:

$$F(t) = F_0 [1 + M_F \sin(\omega t + \phi)], \quad (7)$$

where F_0 is the average fluorescence intensity, M_F the modulation ratio, and ϕ the phase delay. In the cross-correlation method the detected emission is multiplied by a sinusoidal signal of frequency ω_c ,

$$C(t) = C_0 [1 + M_c \sin(\omega_c t + \phi_c)], \quad (8)$$

where C_0 is the average value of the multiplying function, M_c the modulation ratio, and ϕ_c the phase delay. The resulting product signal is the new function

$$F_0 C_0 [1 + M_F \sin(\omega t + \phi) + M_c \sin(\omega_c t + \phi_c) + M_F M_c \sin(\omega t + \phi) \sin(\omega_c t + \phi_c)]. \quad (9)$$

Using trigonometric relationships the last term in Eq. (9) can be rearranged:

$$M_F M_c [\sin(\omega t + \omega_c t + \Delta\phi) + \sin(\Delta\omega t + \Delta\phi)]/2, \quad (10)$$

where $\Delta\omega = \omega_c - \omega$ and $\Delta\phi = \phi_c - \phi$. If ω_c is chosen to be very close to ω , Eq. (9) contains a constant term, plus a term of frequency ω , plus a term of frequency 2ω , and, finally, a term of frequency $\Delta\omega$. This last term contains all the phase and modulation information of the original fluorescence signal and can be totally filtered from the remaining terms.

For synchrotron radiation the light intensity cannot be approximated by a pure sinusoidal signal. Furthermore, in real systems the electronic signal used for the cross-correlation product is also not purely sinusoidal.⁵ The effect of the harmonic content of the $F(t)$ and $C(t)$ signals is discussed next.

D. Analysis of the harmonic content

For a pulsed source the exciting light can be approximated by the series

$$I(t) = \sum I_k \sin(k\omega t + S_k), \quad (k = 0, 1, 2, \dots), \quad (11)$$

where I_k is the amplitude at frequency $k\omega$, S_k is a phase shift characteristic of each frequency, and ω is the base repetition frequency. The modulation of the exciting light is defined as the ratio of the intensity at a given frequency to the intensity at zero frequency. Each individual harmonic at a frequency $k\omega$ is attenuated and phase shifted by the fluorescence sample. The signal detected by the photomultiplier due to the emission has the form

$$F(t) = \sum F_k \sin(k\omega t + \phi_k). \quad (12)$$

The cross-correlation signal for the modulation of the photomultiplier response can be described by a similar expression

$$C(t) = \sum C_l \sin(l\omega_c t + \phi_{c,l}). \quad (13)$$

The waveform at the output of the photomultiplier, after the cross-correlation product is obtained, is

$$V(t) = \sum F_k \sin(k\omega t + \phi_k) \sum C_l \sin(l\omega_c t + \phi_{c,l}). \quad (14)$$

The average value of $V(t)$ is given by the term at zero frequency

$$\langle V(t) \rangle = F_0 C_0. \quad (15)$$

This voltage constitutes the dc signal.

To calculate the harmonic content of $V(t)$ consider the term at the lowest frequency. If ω_c is very close to ω the lowest frequency term corresponds to $\Delta\omega = \omega_c - \omega$ and is obtained for $k = 1$ and $l = 1$:

$$F_1 C_1 \sin(\omega t + \phi_1) \sin(\omega_c t + \phi_{c,1}). \quad (16)$$

This term is the only one giving a frequency $\Delta\omega$. All other combinations of k and l give a frequency $2\Delta\omega$ or greater. This term at $\Delta\omega$ is called the ac signal. The modulation, i.e., the ac/dc ratio is given by

$$M = F_1 C_1 / F_0 C_0. \quad (17)$$

In practice we measure the modulation of the fluorescence with respect to the modulation of a scatter solution, a quantity called the modulation ratio. This ratio depends only on the demodulation of the fluorescence signal and not on the details of the electronics.

III. DESCRIPTION OF THE INSTRUMENTATION

A. Optical arrangement

The light port utilized is situated on the second floor of the PULS facility at Frascati. The light for this port is obtained from a ring section of about 10 mrad at one of the bending magnets. A mirror sends half of this light to the second floor where another mirror splits the beam in two. Finally, the beam is deviated by a plane mirror and passes through a sapphire window. From this point on the light travels in air and, consequently, the spectral region available is limited to wavelengths longer than about 200 nm. Only one-fifth of the original light intensity at the ring is available at our port due to the beam splitting by the mirrors; further

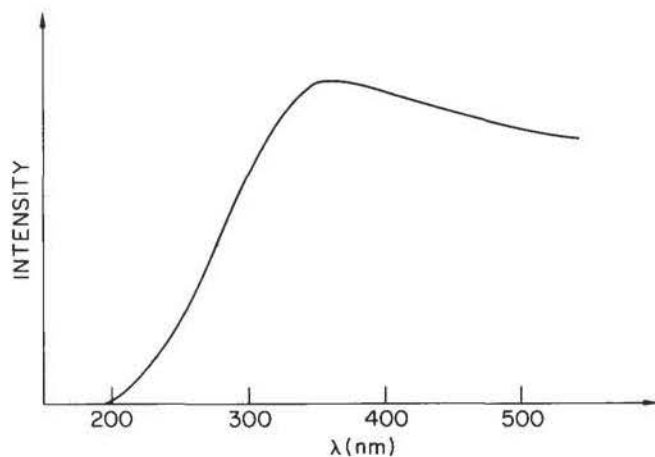

FIG. 3. Spectrum of the incident light passed by the excitation monochromator and detected by the reference photomultiplier.

attenuation by reflection from the various optical surfaces also occurs.

The light is focused by a quartz lens onto the entrance slit of a holographic grating monochromator (SLM) model 320A). The grating has 1500 lines/mm and is maximized at 300 nm. After traversing the monochromator the light enters an optical module (SLM OP 450) equipped with a rotating turret to permit facile exchange between the sample and reference. Standard fluorescence cuvettes as well as solid samples can be employed. For liquid samples a circulating thermostatic bath can be used to control the temperature. Solid samples are mounted on a cryostat which can be used from 4 K to room temperature.

A quartz beam splitter, placed in the optical path prior to the sample, directs a fraction of the exciting light to a reference photomultiplier (Hamamatsu R928) which measures the intensity and phase of the excitation signal. The emission is collected with a large aperture lens and focused onto a photomultiplier (Hamamatsu R928). Generally, the emission is viewed through a suitable cut-off filter or through an interference filter. Calcite prism polarizers can be interposed in the excitation and emission light paths. The spectrum of the exciting light measured with our monochromator/photomultiplier system is reported in Fig. 3, and corresponds to the product of the spectral distribution of the synchrotron radiation and the response characteristics of our system.

B. Cross-correlation electronics

An improvement on the original Spencer and Weber cross-correlation phase fluorometer was recently reported.⁵ In this later version a continuously variable frequency range is available. Virtually the same method of obtaining the cross-correlation frequency was applied to synchrotron radiation. The interested reader can find in Ref. 5 the operational principles of the multifrequency phase fluorometer, as well as a discussion of the possible instrumental artifacts. The repetition frequency of the synchrotron radiation is controlled by a frequency synthesizer (Hewlett-Packard model 3525A) which drives the radio-frequency cavity of the storage ring at 8.568500 MHz (Fig. 4). The frequency for the cross correlation is produced by a second frequency synthe-

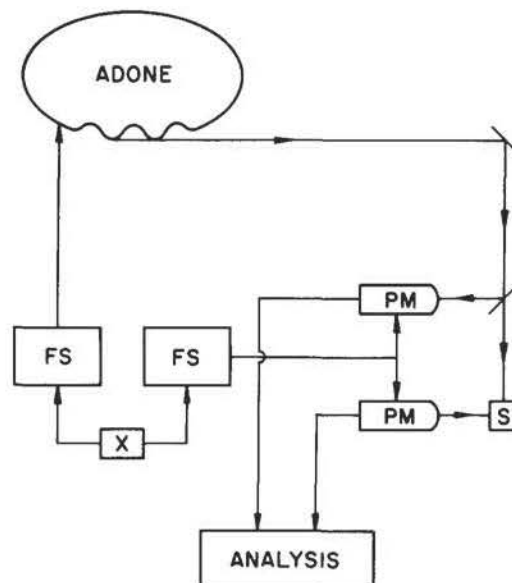

FIG. 4. Block diagram of the instrument. ADONE: storage ring at Frascati; PM: Hamamatsu R928 photomultiplier; S: fluorescence sample; FS: frequency synthesizer; X: crystal oscillator.

sizer (Rockland 5600A) which uses the same crystal oscillator as the Hewlett-Packard synthesizer. The output of this synthesizer, which is phase coherent with the radio frequency of the storage ring, can be varied in order to obtain a frequency equal to the fundamental frequency, or to one of the harmonic components, plus 24 Hz. The small difference, 24 Hz, is the cross-correlation frequency. The output of the synthesizer is amplified by a rf power amplifier (ENI 503L), split into two equal parts and applied to the last dynode of the reference and sample photomultipliers. The detail of the photomultiplier circuit is described in Ref. 5. The cross-correlation frequency at 24 Hz was extremely stable in both the short and long term. Over a period of 2 h the maximum deviation of the cross-correlation frequency was less than 0.01 Hz. This stability implies that the oscillations of the electron beam in the storage ring are time averaged and do not influence the phase delay and modulation ratio measurements.

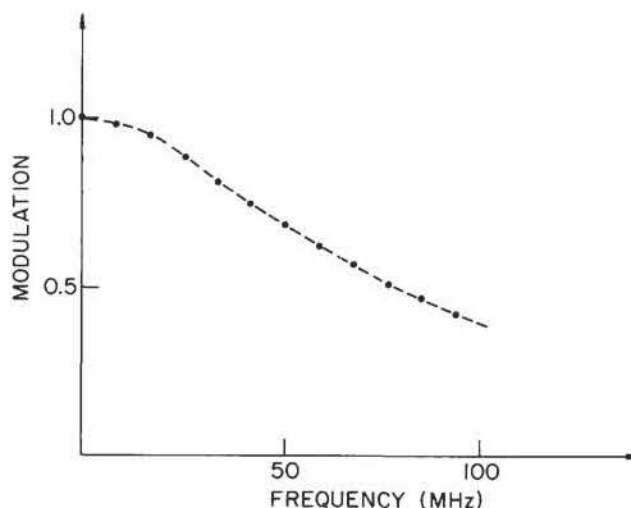

FIG. 5. Relative modulation measured at harmonic frequencies below 100 MHz.

Due to the limited range of the frequency synthesizer utilized, the phase delay and the modulation ratio were measured at each harmonic frequency only up to 100 MHz. In principle higher frequencies can be used, but the real limit then becomes the frequency response of the detector. The photomultiplier employed (Hamamatsu R928) has a maximum operational frequency of about 200–300 MHz. In Fig. 5 we report the measured modulation ratio as a function of the frequency for a scattering solution. Frequencies as high as 100 MHz are attenuated only one-half with respect to the fundamental, demonstrating that high-frequency measurements are feasible.

C. Electronic detection system

The electronic module for signal acquisition and analysis was built from commercial components. In Fig. 6 we report a block diagram of the electronics. The output of the two photomultipliers are analyzed separately by two identical channels. In the following we describe the operation of only one of the channels.

After an initial amplification stage (A1), the signal is separated into dc and ac components. The dc component is integrated (I) in order to generate a dc signal proportional to the average intensity of the detected signal. The ac component is amplified (A2) and filtered by a bandpass active filter (F) to select the 24-Hz component. The output of the filter is rectified (R) and integrated (I) to produce a continuous voltage proportional to the ac component. The dc and ac parts of each channel are continuously monitored by four digital voltmeters. These voltmeter readings are not utilized for data acquisition, but only for rapid inspection of the signal levels. Accurate measurements of the signals are carried out by a precision-integrating digital voltmeter (DVM) consisting of a voltage-to-frequency converter (V/F) and counting electronics. A switch (S1) selects the signal (ac or dc) input to the counter which is timed by a 1-MHz clock. The resolution of the DVM is 0.1 mV per 1-s integration time. The digitized dc or ac components are presented on a six-digit display. The ratio of the ac to the dc part can be obtained by replacing the 1-MHz clock by the output of the V/F converter utilized for the dc component (switch S2). In the ratio mode the resolution of the modulation measurement is 1/10 000. The phase difference between the reference and the sample signal is measured by a digital phasemeter. The output of the two active filters (channel 1 and channel 2) are sent to zero-cross-

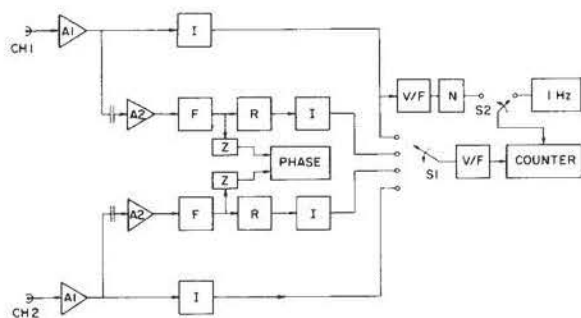

FIG. 6. Block diagram of the electronic detection system. A1, A2: low-frequency amplifiers; I: integrator; F: bandpass filter at 24 Hz; R: rectifier; Z: zero-crossing detector; V/F: 100-kHz voltage-to-frequency converter.

ing detectors (Z), where two square waves are produced. The positive-going edge of these square waves is used to start and stop the phase counter. The input of the phase counter is the 1-MHz clock. The content of the counter, in microseconds, is proportional to the phase difference between the signals from the two channels and is monitored by a six-digit display (phase display). The resolution for phase measurements is 1 μ s, which corresponds to an angular resolution of about 0.01°. One may integrate phase readings for effective integration periods of 1, 2, or 8 s.

IV. APPLICATIONS

A. Instrument performance tests

A large number of measurements were performed with the aim of testing the resolution, sensitivity, accuracy, and reproducibility of the lifetime determinations. Well-characterized fluorophores with lifetimes ranging from 100 ps to 30 ns were studied utilizing the entire attainable frequency range.

1. Short lifetimes; accuracy

A solution of *p*-terphenyl in cyclohexane was excited at 280 nm (8-nm slits) and the emission was observed through a cut-off filter ($\lambda_{em} > 350$ nm). The solution was thermostated at 20°C but was not degassed; the optical density at 280 nm was 0.1. In Fig. 7 the phase and modulation values corresponding to this emission are plotted. The solid lines correspond to a fit using a single exponential with $\tau = 0.973 \pm 0.027$ ns. The fit is obtained using the nonlinear least-squares routine described by Jameson and Gratton.¹¹ We note that (a) the fit to a single exponential is quite good as judged by the value of the reduced X^2 , (b) the measured lifetime corresponds to the literature value,¹² and (c) frequency-dependent systematic errors do not occur.

2. Long lifetimes; color errors

The lifetime of a solution of DENS (2, 5, diethylaminoethyl-naphthalenesulfonate) in water was measured. The excitation wavelength was 360 nm and the emission was measured using a cut-off filter ($\lambda_{em} > 420$ nm). The purpose of

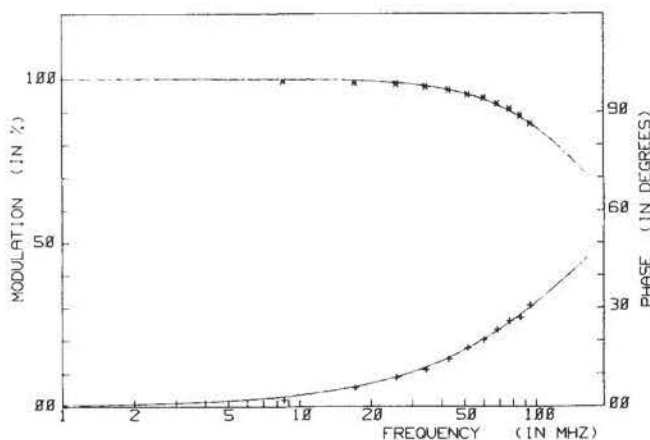

FIG. 7. Multifrequency phase (+) and modulation (*) data for *p*-terphenyl in cyclohexane at 20°C. Solid lines correspond to the best fit using a single-exponential component $\tau_0 = 973 \pm 27$ ps.

TABLE I. Lifetimes for DENS in water: $\lambda_{em} > 420$ nm; τ^P and τ^M in ns.

Frequency (MHz)	λ_{exc} τ^P	240 nm τ^M	λ_{exc} τ^P	360 nm τ^M
8.568	—	—	30.572	30.351
17.137	—	—	29.401	30.315
25.705	30.417	30.395	29.289	30.304

this experiment was to study color delays. Jameson and Weber¹³ have shown that the color delay will be amplified using a long-lifetime fluorophore. At high-modulation frequency a large apparent value of lifetime can be measured using phase data if there is a lengthening of the phase due to color effect. (A recent pulse study by Ware *et al.*¹⁴ reported on the wavelength-dependent timing response for the Hamamatsu R928 photomultiplier, the same photomultiplier utilized in our work.) In Table I we report the measured values of lifetimes using phase and modulation data for DENS. No apparent lengthening is detected. On the contrary, a small shortening of the phase lifetime is observed. This result is consistent with a very weak component of short lifetime.

3. Reproducibility

To test the reproducibility of the measurements we performed a series of lifetime determinations on solutions of NADH. At 2-h intervals fresh solutions were prepared and the lifetime was measured at 94.253 MHz. Excitation was at 340 nm and the emission ($\lambda_{em} > 380$ nm) was observed through a cut-off filter. In Table II we report the result of this study. The errors shown in Table II correspond to the standard deviation of a series of six successive lifetime determinations for each sample. All phase lifetime determinations fall in a range of 6 ps. Normal operating conditions were used; no attempt was made to work in the best instrumental condition (maximum ring current, longer averaging time, etc.).

4. Sensitivity

To test the sensitivity of the instrument the lifetimes of two weakly emitting fluorophores, *bis*-ANS and *bis*-TNS (*bis*-toluidyl-aminonaphthalenesulfonate),¹⁵ were measured. The phase and modulation data obtained for *bis*-ANS are reported in Fig. 8. The excitation wavelength was 370 nm (8-nm slits) and the emission was observed through a cut-off filter ($\lambda_{em} > 430$ nm). The least-squares analysis of the data show a single component of 196 ± 10 ps. For *bis*-TNS in water an even shorter lifetime, 113 ± 5 ps, was measured. We should note that at the normal optical densities used

TABLE II. Lifetimes for NADH in water: λ_{exc} 340 nm; $\lambda_{em} > 420$ nm (Frequency = 94.253 MHz).

Sample #	Phase lifetime	Modulation lifetime
1	464 ± 11 ps	494 ± 14 ps
2	470 ± 4 ps	499 ± 9 ps
3	470 ± 5 ps	478 ± 18 ps
4	471 ± 10 ps	474 ± 20 ps

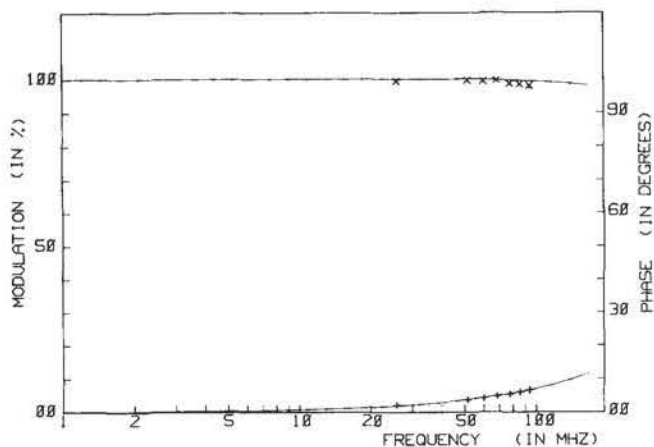

FIG. 8. Multifrequency phase (+) and modulation (x) data for *bis*-ANS in water at 20°C. Solid lines correspond to the best fit using a single-exponential component $\tau_0 = 196 \pm 10$ ps.

(< 0.1 O.D.) the emission intensities of these compounds are comparable to the water Raman band intensity.

B. Tryptophan studies

An extensive study was performed on tryptophan solutions at two different pH values. Tryptophan is the most important natural occurring fluorescent amino acid in proteins and its fluorescence has been largely characterized, although controversies persist regarding the molecular origin of the emission properties. Our measurements confirm some of the findings which have been debated in the literature. Our results also demonstrate the applicability of the experimental protocol to double-exponential decaying systems.

1. Neutral pH; single-exponential decay

Phase and modulation values of a tryptophan solution at pH = 6.9 in 55-mM sodium phosphate buffer at 20°C were measured. The excitation wavelength was 280 nm using 4-nm slits, and the emission was analyzed using a Corning 0-

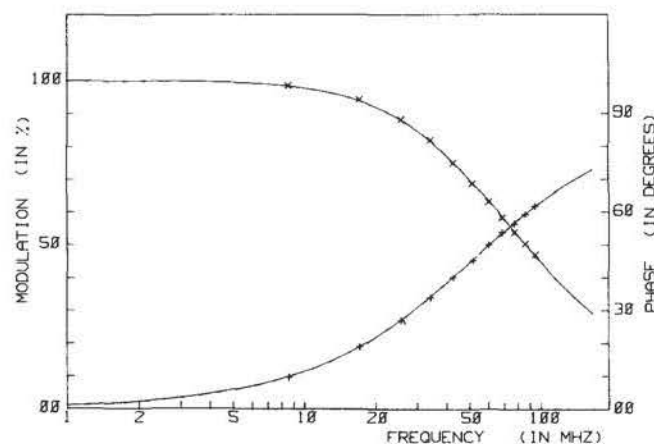

FIG. 9. Multifrequency phase (+) and modulation (x) data for tryptophan at 20°C pH = 6.9. Solid lines correspond to the best fit using two exponential components: $\tau_1 = 3.106 \pm 0.013$ ns, $\tau_2 = 9.00$ ns, and $f_1 = 0.968 \pm 0.005$.

TABLE III. Results of heterogeneity analysis on tryptophan lifetimes. Two-component analysis.

Condition	τ_1 (ns)	τ_2 (ns)	f_1	χ^2
pH 6.9 $\lambda_{em} > 350$ nm	3.106 ± 0.013	9.000 (fixed)	0.968 ± 0.006	0.852
pH 9.25 $\lambda_{em} > 350$ nm	3.193 ± 0.047	9.000 (fixed)	0.396 ± 0.099	6.093
pH 6.9 $\lambda_{em} = 313$ nm	3.117 ± 0.275	0.742 ± 0.878	0.896 ± 0.104	16.627
	3.106 (fixed)	0.710 ± 0.218	0.900 ± 0.016	4.181

52 filter ($\lambda_{em} > 350$ nm). The results are presented in Fig. 9. The analysis using the nonlinear least-squares routine gives a double-exponential decay with a very small amount of a long component, corresponding to a small fraction of the anion form present at high *pH* (Table III).

2. Alkaline *pH*; double-exponential decay

Using the same experimental conditions described in the previous paragraph, phase and modulation values of a tryptophan solution at *pH* = 9.25 were measured and the results reported in Fig. 10. The solid lines correspond to the best fit obtained using two exponential components. The derived values for the lifetime and fractional contribution of each component are also reported in Table III. The component lifetimes are in good agreement with the values expected for a mixture of the zwitterionic and anionic form of tryptophan. This experiment also shows the resolving power of the instrumentation for a two-component system.

3. Short-wavelength component

The decay of the tryptophan emission was measured at an emission wavelength of 313 nm using an interference filter (bandwidth 4 nm). The aim of this experiment was to test for the existence of a fast component at short wavelength as reported by Rayner and Szabo.¹⁶ The result of the two-component analysis using the nonlinear least-squares routine is presented in Table III. The results are in close agreement with the values reported by Rayner and Szabo; also, the er-

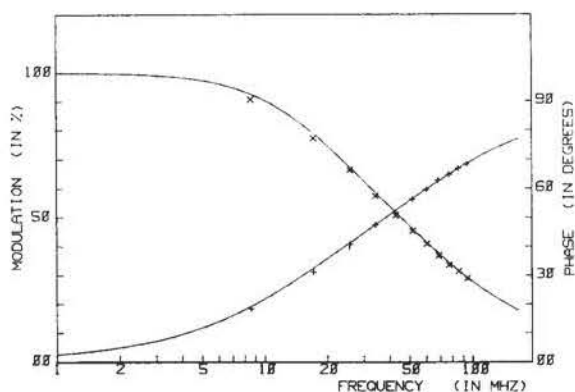

FIG. 10. Multifrequency phase (+) and modulation (x) data for tryptophan at 20°C *pH* = 9.25. Solid lines correspond to the best fit using two exponential components: $\tau_1 = 3.193 \pm 0.026$ ns, $\tau_2 = 9.00$ ns, and $f_1 = 0.396 \pm 0.005$.

ror on the short component is markedly reduced when the value of the long component is fixed in the analysis.

V. QUANTITATIVE COMPARISON BETWEEN SPC AND PHASE TECHNIQUES USING SYNCHROTRON RADIATION

A. Light intensity

In normal SPC operation a maximum of one photon is detected for each incident light pulse. This limitation is of no consequence if the average number of emitted photons per second is less than the average number of pulses per second since, in that case, all emitted photons are collected. In phase fluorometry all photons are collected irrespective of the average number of emitted photons per second.

In our experiments at Frascati we have measured an average photocurrent of about 10^{-6} A in a typical fluorescence experiment which translates to about 10^6 photons detected per second given the gain of the photomultiplier (Hamamatsu R928 at 900 V). This counting rate is quite high for single-photon counting experiments and could result in the loss of some counts due to pulse pileup. However, it is fair to say that if such signal intensity is available, SPC experiments are very easy to perform. We have also carried out measurements with an intensity corresponding to 1000 to 10 000 photons per second using an integration time of 8 s, and reliable values of phase and modulation have been obtained. We believe that the lower limit for the light level for the present phase fluorometer is in the range of 100 to 1000 photons per second. This figure provides a quantitative evaluation of the sensitivity of the instrument.

We conclude that phase methods or SPC methods are comparable regarding sensitivity. If the signal intensity is low then both methods use all the photons and are equivalent; if the signal intensity is high, although phase methods make better use of all the photons, the sensitivity of single-photon counting is sufficient for all practical purposes.

B. Deconvolution for the finite pulse width

Using phase methods there is no deconvolution for the finite light pulse width and for the electronic response of the detection system because phase delays and modulation ratios are measured relative to the incident radiation. The problem of deconvolving for the finite pulse width of the system, which is a major problem of pulse methods,^{17,18} is greatly simplified when synchrotron radiation is employed, because the shape of the pulse is known *a priori* and is invariant from pulse to pulse in the single-bunch mode. However, for the measurements of lifetime of the order of 1 ns or less, the deconvolution can be important even using synchrotron radiation, because the decay time can be within the pulse width (depending on the particular synchrotron radiation source employed). With respect to the deconvolution problem, phase fluorometry offer a distinct advantage.

C. Differential measurements

Phase methods are intrinsically differential because the phase delay is measured with respect to a reference phase.

The reference can be conveniently chosen and usually, for an absolute lifetime measurement, the phase delay and modulation ratio of the emission are measured with respect to a scattering sample which is assumed to have the phase and modulation ratio of the incident radiation. Instead of the scattering sample, a different reference can be chosen. For example, for the measurement of the decay of the emission anisotropy the phase delay of the light emitted with parallel polarization (with respect to the excitation) is measured with respect to the phase delay of the light emitted with perpendicular polarization. Following the theory of differential phase fluorometry,¹⁹ this measurement, when carried out as a function of the frequency, contains the same information as the decay of the emission anisotropy using pulse methods. The differential method has the same accuracy as the absolute lifetime measurement, because only two phase measurements are necessary in each case. Another interesting application of differential measurements is the detection of the delay of the emission of the blue and red part of the spectrum of certain molecules.²⁰

The direct differential method is not available for SPC. A differential operation can be performed, as shown recently,²¹ by deconvolution of the pulse response by an appropriate function. For example, if the pulse response in the blue part of the spectrum is known for a given molecule, then the difference between red and blue emission can be obtained by deconvolution of the red response using the blue response. The differential deconvolution method is the equivalent of the differential phase (and modulation ratio) measurement. Needless to say, a computer is always necessary in order to obtain the desired deconvolution from the pulse response. For differential phase measurements the desired phase difference is directly available.

D. Thinking of phase methods in terms of single-photon counting

A more quantitative comparison between phase fluorometry and single-photon counting decay measurements can be made if we perform measurements of phase delay and modulation ratios using single-photon counting techniques as suggested below.

Suppose we fix the modulation frequency at 100 MHz. Consider now a period at that frequency, and suppose we want to measure the phase and modulation of the fluorescence with respect to a reference. Divide the period in 360 bins of 1° each and count the photons in each bin for a fixed amount of time. Once the photons have been collected reconstruction of the emitted sine wave and determination of the phase delay and modulation ratio of the fluorescence with respect to the reference is straightforward. Instead of 360 bins we can equally well use 4 bins of 90° each. Furthermore, instead of measuring phase delay and modulation ratio at 100 MHz, we can continue to use the cross-correlation principle and perform the measurement at 24 Hz. In this case the cross-correlation product at the photomultiplier can be seen as a gating of the photomultiplier with a square wave that can be shifted by 90° for each bin. Evidently, using this method we lose one-half of the photons because the photomultiplier is turned on for only half a period. The procedure sug-

gested above is exactly what is done in phase fluorometry, however, instead of using photon counting, we use analog detection. Because the signal noise is very low in the bandwidth of our experiment (0.1 Hz at 100 MHz), the two methods, bin collection and analog detection, are completely equivalent.

E. Discussion

There may be some cases in which the time domain cannot be substituted by the frequency domain. In fact the frequency domain measurement requires a repetitive source. The comparison here is made only for high repetition rate frequency sources. This requirement restricts us to synchrotron radiation, mode-locked lasers, and modulation of cw sources. Furthermore, we are primarily interested in very fast decays, on the order of a few nanoseconds to picoseconds. In this particular time range, the measurement in the frequency domain appears to be equivalent or superior to the direct time recording. This superiority is due to the higher sensitivity, to the fact that no deconvolution for the finite time response of the system is needed, to the possibility of performing direct differential measurements, and to the high-intrinsic accuracy of phase delay and modulation ratio measurements.

Finally, we note that phase methods provide an absolute measurement of the lifetime. The calibration of the time scale, an operation always necessary in the time domain, is not required in the frequency domain.

ACKNOWLEDGMENTS

We are deeply indebted to the staff of the PULS laboratory at Frascati for their invaluable help during the construction of the phase fluorometer. In particular, we are grateful to F. Antonangeli, F. Bassani, F. Campolungo, U. Grassano, A. Finazzi-Agro, M. Piacentini, and N. Zema. Financial support for this research was in part provided by NSF Project No. 82-FR-47. We also want to acknowledge the financial support of the Italian CNR during the 6-month period of activity at the Frascati storage ring for one of us (EG).

- ¹R. D. Spencer and G. Weber, *Ann. N. Y. Acad. Sci.* **158**, 361 (1969).
²F. W. J. Teale, in *Time Resolved Fluorescence Spectroscopy in Biochemistry and Biology*, edited by R. B. Cundall and R. E. Dale (Plenum, New York, 1983), Vol. 69A, pp. 59.
³D. M. Jameson, E. Gratton, and R. D. Hall, *Appl. Spectrosc. Rev.* (in press).
⁴E. Gratton, D. M. Jameson, and R. D. Hall, *Ann. Rev. Biophys. Bioeng.* **13**, 105 (1984).
⁵E. Gratton, and M. Limkeman, *Biophys. J.* **44**, 315 (1983).
⁶H. P. Haar and M. Hauser, *Rev. Sci. Instrum.* **49**, 632 (1978).
⁷F. Dushinsky, *Z. Phys.* **81**, 7 (1933).
⁸E. Gratton and R. Lopez-Delgado, *Nuovo Cimento B* **56**, 110 (1980).
⁹A. P. Sabersky and I. H. Munro, in *Picosecond Phenomena*, edited by C. V. Shank (Springer, New York, 1979).
¹⁰P. Sebban and I. Moya, *Biochim. Biophys. Acta* **722**, 436 (1983).
¹¹D. M. Jameson and E. Gratton, in *New Directions in Molecular Luminescence*, edited by D. Eastwood (American Society for Testing and Materials, Philadelphia, 1983), pp. 67.
¹²L. Brand, J. B. A. Ross, and W. R. Laws, *Ann. N. Y. Acad. Sci.* **366**, 197

- (1982).
- ¹³D. M. Jameson and G. Weber, *J. Phys. Chem.* **85**, 953 (1981).
- ¹⁴W. R. Ware, M. Pratinidhi, and R. K. Bauer, *Rev. Sci. Instrum.* **54**, 1148 (1983).
- ¹⁵F. J. Farris, G. Weber, C. C. Chiang, and I. C. Paul, *J. Am. Chem. Soc.* **100**, 4469 (1978).
- ¹⁶D. M. Rayner and A. G. Szabo, *Can. J. Chem.* **56**, 743 (1978).
- ¹⁷A. G. McKinnon, A. G. Szabo, and D. R. Miller, *J. Phys. Chem.* **81**, 1564 (1977).
- ¹⁸D. V. O'Connor, W. R. Ware, and J. C. Andre, *J. Phys. Chem.* **83**, 1333 (1979).
- ¹⁹G. Weber, *J. Chem. Phys.* **66**, 4081 (1977).
- ²⁰J. R. Lakowicz, H. Cherek, and D. Bevan, *J. Biol. Chem.* **225**, 4403 (1980).
- ²¹J. R. Lakowicz and A. Balter, *Biophys. Chem.* **16**, 223 (1982).