

UC Merced

Proceedings of the Annual Meeting of the Cognitive Science Society

Title

Complex Mental Time Travel

Permalink

<https://escholarship.org/uc/item/718723m7>

Journal

Proceedings of the Annual Meeting of the Cognitive Science Society, 35(35)

ISSN

1069-7977

Author

Stocker, Kurt

Publication Date

2013

Peer reviewed

Complex Mental Time Travel

Kurt Stocker (kurt.stocker@psychologie.uzh.ch)

Department of Psychology, Binzmühlestrasse 14/22
8050 Zürich, Switzerland

Abstract

This article argues that investigating the conceptual structure underlying the use of the pluperfect and the future perfect reveals a new complex type of nested dual mental time travel: mental time travel into posteriority embedded into mental time travel into “anteriority in the past” (underlying the pluperfect) versus mental time travel into posteriority embedded into mental time travel into “anteriority in the future” (underlying the future perfect). Additionally this article also offers the following novel notions for temporal cognition: a mental time line where past/anteriority and future/posteriority have become nondispersible; dual temporal direct viewings at the present moment; and looking into the future from the past (rather than the more typical looking into the future from the present moment). Implications for cognitive modeling are discussed.

Keywords: mental time travel; tense system; Talmyan concept structuring; Talmyan perspective point (PP); mental time line; models

Introduction

Until recently mental time travel has mainly been characterized as mentally construing oneself as looking forward or backward in time from the present moment (e.g., Addis et al., 2009; Schacter & Addis, 2007; Tulving, 1972, 2002). By synthesizing findings from cognitive psychology and cognitive linguistics and by additionally applying cognitive-linguistic methodology, Stocker (2012a) then introduced the idea—based on a sketch by Talmy (2000, pp. 86–87)—that in addition to this basic type of mental time travel there might also be more complex types of mental time travel. For instance: a person may mentally construe herself as looking back from the present moment to a particular point in time in the past, but may additionally also conceptualize herself as mentally looking forward from this past point to a “later time” that is still in the past. Such examples have been referred to as examples of nested dual mental time travel (“mental time travel embedded within mental time travel”) (Stocker, 2012a, p. 408). Investigating the conceptual structure underlying the linguistic use of *before/after* sentences that additionally are set in the past or future tense, Stocker (2012a) has thus far basically identified one form of nested dual mental time travel: mental time travel into anteriority or posteriority (underlying *before/after*) embedded in mental time travel into the past or future (underlying past/future tense). It is important to distinguish anteriority/posteriority (“earliness/lateness”) from past/future since the former is more generic and does not depend upon the present moment as a reference point (e.g., Núñez & Sweetser, 2006, p. 404). For instance: One event may have occurred later in time

than another event (say my first day at school versus my birth), but both events have occurred in the past.

This article investigates how this anteriority/posteriority versus past/future distinction can help us to reveal the temporal-conceptual structure underlying the pluperfect and future perfect. The theoretical strategy I adopt is the same as used in Stocker (2012a): using language as an entree to a conceptual level that seems deeper than language itself (Pinker, 2007; Talmy, 2000). This strategy is supported by recent findings that many conceptualizations observed in relation to our use of language also exist in mental representations that are more basic than language itself (e.g., Boroditsky, 2000; Casasanto & Boroditsky, 2008; McGlone & Harding, 1998; Núñez, Motz, & Teuscher, 2006). In the present investigation language can assist us to identify complex forms of mental time travel—complex forms of how we can mentally project through time.

The basic theoretical framework used is Talmyan concept structuring (Talmy, 2000), with the further refinement for temporal cognition by Stocker (2012a). There are many other basic theoretical frameworks that one could adopt when investigating the conceptual structure underlying the tense system or the conceptual structure of mental time in general—for example: formal accounts of tense (e.g., Comrie, 1985; Declerck, 1986; Jespersen, 1924; Reichenbach, 1947), conceptual semantics (Jackendoff, 1987, pp. 398–402; cf. also Pinker 1989, pp. 205–206), formal semantics (e.g., Bennett & Partee, 1978; Montague, 1973; Pendlebury, 1992), or temporal (tense) logic (e.g., Allen, 1984; Kowalski & Sergot, 1986; Lichtenstein & Pnueli, 2000; Prior 1967). While the current investigation is basically set in a Talmyan framework, it also, as we will see, benefits greatly from the formal-tense analysis of Comrie (1985).

One of the main motivations for choosing Talmyan concept structuring as a basic theoretical framework for the present investigation is that it offers a ready means to incorporate mental temporal perspective (Stocker, 2012a; Talmy, 2000, pp. 68–76+86–87). In the other above-mentioned approaches (formal tense, conceptual semantics, formal semantics, temporal logic), mental perspective is usually not considered or is only mentioned marginally, without incorporating it into the formal descriptive apparatus (e.g., in Jackendoff, 1987, p. 399). In contrast, in Talmyan concept structuring, perspective is an integral part of the overall theoretical descriptive system.

The present investigation will reveal several basic novel notions in relation to temporal cognition (as summarized in the discussion section). It will also be discussed if the current account of complex mental time travel could be used to refine modeling approaches which have incorporated mental

temporal perspective into their models (Brown, Neath, & Chater, 2007).

Mental time travel underlying the pluperfect

Undertaking an extensive cross-linguistic investigation, the linguist Bernard Comrie characterizes the temporal-relational structure of the pluperfect (*I had already eaten when ...*) in the following way:

“The meaning of the pluperfect is that there is a reference point in the past, and that the situation in question is located prior to that reference point, i.e. the pluperfect can be thought of as ‘past in the past’” (1985, p. 65).

As we will see later on in this section, a still more refined characterization of the meaning of the pluperfect—rather than saying that it signifies “past in the past”—is to characterize it as “anteriority in the past.” To start investigating the temporal-conceptual structure underlying the pluperfect, we use one of Comrie's own examples for illustration (1985, p. 66):

(1) John had already left when Mary emerged from the cupboard.

According to Comrie the temporal relations underlying the use of the pluperfect can be formalized in the following terms (1985, p. 125):

(2) pluperfect: E before R before S

E stands for the event which is to be located in time. In Comrie's example, the event of John's leaving is the event to be located prior to Mary's emerging from the cupboard. Hence the event in the pluperfect clause (John's leaving) is E. R stands for the temporal reference point in relation to which E is defined. Thus Comrie's formula correctly predicts that E (John's leaving) occurs before R (Mary's emerging from the cupboard). S stands for moment of speech (i.e., the present moment). Comrie's formula again correctly predicts that R (Mary's emerging from the cupboard) occurs before S (the present moment).¹

¹ Comrie's (1985) ERS notation for the pluperfect represents a further development—and major departure—from the famous tense formulations of Reichenbach (1947, pp. 287–298; cf. also Jespersen, 1924, pp. 262–264). Comrie's formulations are mainly taken over because it is Comrie's analysis that allows one to characterize the pluperfect as involving “anteriority in the past” and the future perfect as involving “anteriority in the future”—which has major implications when one adds mental perspective to the pluperfect and future perfect constructions, as shall be demonstrated in this article. Taken over from Prior in the analysis in this paper, is the argumentation that there is no need to—as Reichenbach does—“make such a sharp distinction between the point or points of reference and the point of speech” (1967, p. 13). This is so, as also pointed out by Prior, because the present moment (“the point of speech”) itself can function as a reference point. This argumentation of Prior is taken over by allowing the present moment to function as a Ground (see below in this article). “Ground” is the Talmyan technical term for what one might also refer to as a “ref-

As has just been demonstrated, (2) can correctly predict all temporal-relational structure of the pluperfect. The question we now turn to is: How could mental temporal perspective (Stocker, 2012a; Talmy, 2000, pp. 72–76+86–87) be added to this basic account of the temporal-relational structure of the pluperfect? One theoretical solution to this question, the one to be adopted in this article, is to integrate Comrie's findings into the theoretical framework of Talmy—an concept structuring—because Talmyan concept structuring can describe temporal relations and temporal perspective in one coherent theoretical framework (Stocker, 2012a; Talmy, 2000). As a starting point, let us reformulate Comrie's pluperfect formula in Talmyan terms. In Talmyan concept structuring spatial or temporal relations are captured with the notions of Figure (F) and Ground (G) (Talmy, 2000). In temporal Figure/Ground, one event serves as temporal reference point—G—in relation to which the temporal location of the other event—F—is defined. Thus (2) can be captured in the following way in Talmyan terms:

(3) pluperfect: F₁ before G₁; F₂ (G₁) before G₂ (G₂ = present moment)

We again exemplify the formalized temporal relationship with (1). Now it is F₁ which stands for the event which is to be located in time (John's leaving). G₁ stands for the temporal reference point (Mary's emerging from the cupboard) in relation to which F₁ is defined. Thus (3) correctly predicts that F₁ (John's leaving) occurs before G₁ (Mary's emerging from the cupboard). However, G₁ also functions as another F, since the temporal position of G₁ is also defined in relation to the present moment. Hence, one is in a position to postulate that G₁ (Mary's emerging from the cupboard) also functions as an F (a second F in the overall temporal complex: F₂) whose temporal position is defined in relation to the present moment (which functions as a second G: G₂). Thus, (3) also correctly predicts that F₂ (Mary's emerging from the cupboard) occurs before G₂ (the present moment).

Thus far, Comrie's pluperfect (2) and the Talmyan pluperfect (3) formalization are equipotent in terms of theoretical explanatory power: they both correctly predict the complex temporal relations that underlie our use of the pluperfect. But having it phrased in Talmyan terms allows us now to add mental temporal perspective (Stocker, 2012a; Talmy, 2000, pp. 72–76+86–87) to the temporal-relational description. Both Talmy and Stocker have cognitive-linguistically argued in detail that a complex temporal sentence (a temporal sentence with a main and a subordinate clause) underlies a temporal direct viewing of the F event in relation to the content of the main clause and a temporal indirect (prospective or retrospective) viewing of the G event in relation to the content in the subordinate clause. Taking over this analysis (see Stocker, 2012a; Talmy, 2000, pp. 72–76+86–87 for argumentation), we derive at the (perspective-

reference point.” For a different theoretical approach to the notion of a temporal perspective point see Declerck (1986, pp. 320–321).

including) temporal-conceptual structure underlying our use of the pluperfect as it is depicted in Fig. 1.

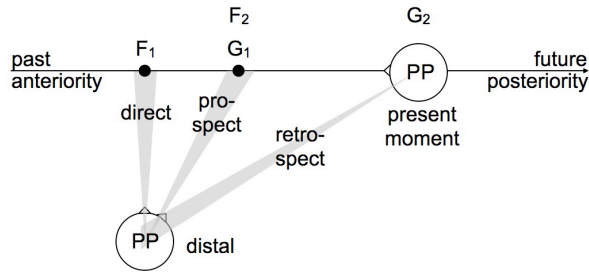

Figure 1: Mental time travel into posteriority (to G_1) embedded into mental time travel into anteriority in the past (to the F_1 -co-located PP), a nested dual form of mental time travel underlying the pluperfect. This temporal-conceptual structure (and the cognition thereof) is in many respects identical to the one proposed by Stocker (2012a) for before/past-tense constructions (p. 408). However, the crucial difference is that in before/past-tense constructions there are two distinct temporal Reference Frames (anteriority/posteriority and past/future RFs) whereas in constructions containing a pluperfect these two RFs have fused into one larger, more complex anteriority-past/posteriority-future RF.

When taking a look at this figure, the temporal structure (and perspectival cognition thereof) might at first glance seem identical to the conceptual structure underlying our use of a temporal complex sentence containing *before* and the past tense (a before/past-tense construction like *I shopped at the store before I went home*; cf. with Fig. 9 in Stocker, 2012a, p. 408). This is also not surprising: Comrie's characterization of the pluperfect clause as the "past in the past" could also be paraphrased as "past event before another past event." We should also note that Comrie's pluperfect characterization of "the past in the past" just serves him as a first rough characterization of the pluperfect (he uses the phrase to introduce the pluperfect). Crucially, Comrie notes that in relation to (2):

"Since the relation *before* is transitive (i.e. if X is before Y and Y is before Z, then necessarily X is before Z), one can deduce *E before S* from the representation of the pluperfect, but this is not part of the formal representation of the pluperfect; the importance of this observation will become clear when we discuss the future perfect" (1985, p. 125).

In other words, what Comrie is saying is that the pluperfect is basically speaking not "a past in the past" (i.e., this can only be deduced), but anteriority in the past (since he says that S—the present moment—is in no way directly related to E). All that is inherent in (2)—or (3)—is that the event in the pluperfect must occur earlier than its reference event in the past. As with Comrie, we examine the importance of this observation when we examine the temporal-conceptual structure underlying the future perfect (see next section). The observation that the pluperfect signifies "anteriority in the past" also leads us to the basic temporal-conceptual difference between before/past-tense construc-

tions and complex sentences containing a pluperfect in the main clause and the simple past in the subordinate clause. In a before/past-tense construction, one can identify two distinct temporal Reference Frames (RFs): an anteriority/posteriority RF (underlying *before*) that is embedded in a past/future RF (underlying past/future-tense; as examined in Stocker, 2012a, where the term RF is also technically defined). But in a pluperfect construction, one cannot disentangle the anteriority/posteriority RF and the past/future RF. The observation that the pluperfect stands for "anteriority in the past" means that the temporal conceptual structure underlying the pluperfect has fused these two RFs into a larger complex whole: the pluperfect carries components of both these RFs within it. Trying to tease them apart would result in the dissolving of the sine qua non of the pluperfect: that it refers to an event that must occur earlier than another event in the past. It is in this sense that a pluperfect construction is more complex than a before/past-tense construction: underlying a pluperfect structure is a more complex RF (a mental time line) where components of two separate RF-systems have formed a new complex whole.

Additionally cognitive-linguistic analysis of complex temporal sentences in relation to Talmyan mental perspective points (PPs) suggests that F and G are cognized as points (punctual events) on the mental time line and they are mentally cognized from a distal PP (as detailed in Stocker 2012a; Talmy 2000, pp. 61–62). A distal PP means mentally zooming out as much from an event as to collapse the entire duration of an event to a single temporal point. The self needs to zoom out this much in order to be able to cognize two events—that is the relationship between the two events—from one perspective point. Note also that the observation that the pluperfect indicates that self travels back from the present moment to a point in time prior to another past event (to F_1) means that the reference point in the past (G_1) can only be located in a prospective (later) direction when viewed from the perspective of F_1 . Thus the self at the point in the past that is prior to another event in the past must mentally travel forward in order to establish the posterior reference point (in order to establish G_1). That the self travels from temporal F co-location to G (to establish a reference point at the temporal G point) has been examined in detail for *before/after* temporal constructions (Stocker, 2012a).

Stocker (2012a) also argues in detail (by providing cognitive-linguistic evidence) that the schematic geometric representations, as for instance shown in Fig. 1, are not merely a didactic aid that allows us to illustrate the underlying cognitive-temporal structure. Rather it is proposed that such geometry is actually construed in our mind when we conceptualize time. For instance: the depicted time line is proposed to be an actual, mentally construed spatial structure in our mind that allows for mental time travel—for instance in relation to the pluperfect by projecting one's mental gaze along this mentally construed line once in a retrospective direction (to "anteriority in the past") and once in a prospective direction (to the reference point in the past). The pro-

positional that the “mental time line” is mentally construed when we engage in mental time travel is also supported by a growing number of recent experimental behavioral findings. The mental time line is for instance frequently conceptualized in relation to the cognizer's body along the sagittal (back to front) or transversal (left to right) axis (e.g., Hartmann & Mast, 2012; Miles, Nind, & Macrae, 2010; Ulrich & Maienborn, 2010).

Mental time travel underlying the future perfect

Drawing—as in the pluperfect—extensively on cross-linguistic data, Comrie concludes that the temporal-conceptual structure underlying the future perfect (*I will have eaten when ...*) differs to the one underlying the pluperfect in only one way: the reference point (G_1 in the Talmyan framework) is set in the future rather than in the past (Comrie 1985, p. 69–74). Accordingly, Comrie (p. 126) formalizes the temporal-relational structure underlying the pluperfect in the following way (cf. with (2)):

(4) future perfect: E before R after S

Reformulation in Talmyan concept structuring (cf. with (3)); this will again enable us to integrate PP into the temporal cognition:

(5) future perfect: F_1 before G_1 ; F_2 (G_1) after G_2 (G_2 = present moment)

Both formulations—(4) and (5)—encode a remarkable finding of Comrie about the pluperfect (a finding that holds true cross-linguistically): that all that the future perfect indicates is that there must be a reference point (G_1) in the future—but while the event referred to (F_1) most typically also occurs in the future, it can also occur in the present or even in the past. Comrie:

“Let us start with the example *John will have finished his manuscript by tomorrow*. Let us suppose moreover that I do not know whether or not John has already finished his manuscript (or at least do not wish to reveal this knowledge), but I know (and am prepared to divulge) that he will have finished it by tomorrow – say, because he made a promise to this effect several days ago, and is judged by me to be reliable. Then there are three sets of circumstances in which I can felicitously and truthfully utter this statement. One set of circumstances is where John finishes his manuscript between the moment of my uttering this sentence and the reference point ‘tomorrow’. The second is where John is in fact finishing his manuscript at this very moment, but I am unaware (or wish to give the impression that I am unaware) of this fact. The third is where John has already finished his manuscript, but I am unaware (or wish to appear unaware) of the fact. Thus the time reference of John's finishing his manuscript is left open as to whether it is future, present, or past relative to the present moment, the only stipulation

being that it must be prior to the reference point in the future, the sine qua non of the future perfect” (1985, p. 71).

This leads to three kinds of temporal relations that can underlie our use of the perfect: future perfect with future interpretation, future perfect with present interpretation, and future perfect with past interpretation (Comrie, 1985, p. 70). It is in this context where the anteriority/posteriority versus past/future distinction becomes highly relevant: whereas the structure underlying the pluperfect (by deduction) can be characterized as a “past in the past” (but is more precisely “anteriority in the past”; cf. previous section), this is no longer true for the structure underlying the future perfect. As the analysis of Comrie demonstrates, the temporal relations underlying the future perfect could not (also not by deduction) be characterized as “past in the future” (since this would only correctly characterize the future perfect with past interpretation). The only characterization that can capture the sine qua non of the future perfect is “anteriority in the future”—that is, a reference point (G_1) in the future in relation to which an earlier event (F_1) is defined, an event that can be located in the future, present, or past.

If we now add—as we did with the temporal-conceptual structure underlying the pluperfect—mental temporal perspective (Stocker, 2012a; Talmy, 2000, pp. 72–76+86–87), then these three possible interpretations of the future perfect naturally lead to three different kinds (subtypes) of nested dual mental time travel, as illustrated in Figs. 2–4.

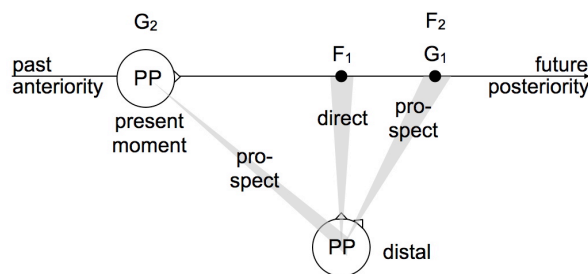

Figure 2: Mental time travel into posteriority (to G_1) embedded into mental time travel into anteriority in the future (to the F_1 co-located PP), where the anterior event is also set in the future—a nested dual form of mental time travel underlying the future perfect with future interpretation.

The temporal-conceptual structure and cognition underlying the future perfect with future interpretation (Fig. 2) is largely identical to complex *before*-sentences that would additionally be marked as occurring in the future (cf. Stocker, 2012a). However, the vital difference is again—as in *before*-past-tense constructions (cf. previous section)—that in a *before*-relation where both events are set in the future there are two distinct temporal Reference Frames (anteriority/posteriority and past/future RFs) whereas in a construction containing a future perfect these two RFs have fused to one larger, more complex anteriority/past-posteriority/future RF where the two RFs can no longer be disentangled.

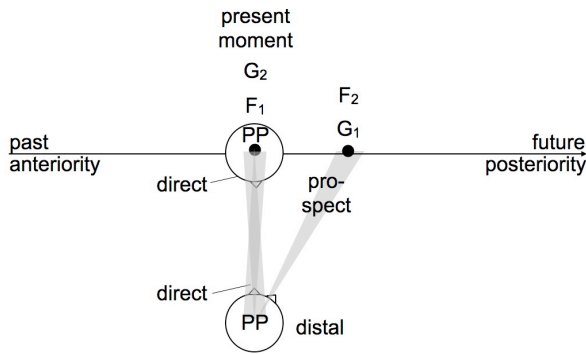

Figure 3: Mental time travel into posteriority (to G_1) embedded in “mental time travel” into anteriority in the future (to the F_1 co-located PP), where the anterior event is set at the present moment, a nested dual form of mental time travel underlying the future perfect with present interpretation.

The novel finding in the temporal-conceptual structure and cognition underlying the future perfect with present interpretation (Fig. 3) is that computational logic requires us to place the self twice at the present moment: the self must be located at the present moment in order to look out at the embedded self that is a distal distance removed from the time line (cf. previous diagrams); the second (embedded) self a distal distance away from the time line (but still co-located with the present moment) needs to look at the present moment on the time line so that F_1 can be cognized in a temporally direct way (cf. also previous diagrams). More technically speaking, the novel proposal is the existence of a dual form of temporal direct viewing, where both viewings are located at or co-located at the present moment. Note also that “mental time travel” into anteriority in the future is not really mental time “travel” in the present-interpretation case—since the anterior point happens to be at the present moment, the self at the present moment must cognize an embedded self a distal distance away from the timeline (but since this all happens at the present moment, the self does not really “travel” anywhere, at least not in a “forward/backward in time” sense).

The major novel observation in the temporal-conceptual structure and cognition underlying the future perfect with past interpretation (Fig. 4) is a looking forward from a past point (from the PP that is co-located with F_1) to a future point (to G_1)—that is, a prospective projection through mental time that starts off in the past and extends (passing by the present moment as it were) right into the future.

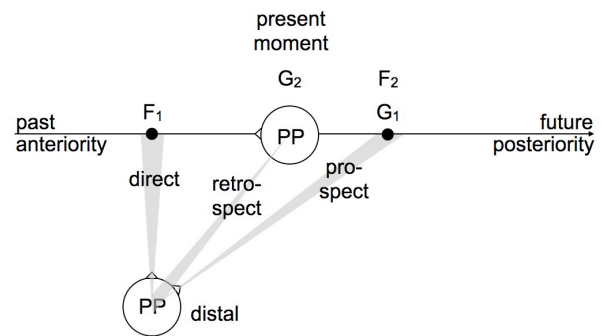

Figure 4: Mental time travel into posteriority (to G_1) embedded in mental time travel into anteriority in the future (to the F_1 co-located PP), where the anterior event is set in the past—a nested dual form of mental time travel underlying the future perfect with past interpretation.

Discussion

The current investigation has—in addition to the findings of Stocker (2012a)—identified one more complex form of mental time travel: mental travel into posteriority embedded into mental time travel into “anteriority in the past” (underlying the pluperfect) versus mental time travel into posteriority embedded into mental time travel into “anteriority in the future” (underlying the future perfect). Additional novel notions include: a mental time line where past/anteriority and future/posteriority have become nondispersible; dual temporal direct viewings at the present moment; and looking into the future from the past (rather than the more typical looking into the future from the present moment). The last two of these novel notions have only been possible to identify because the current investigation uses a basic theoretical approach (Talmyan concept structuring for time: Stocker, 2012a; Talmy, 2000) that inherently incorporates temporal mental perspective into the explanatory framework.

One advantage for cognitive science in general that comes out of the current work (and of Stocker 2012a, 2012b) is that it offers a systematic and detailed explanatory framework how mental perspective can be included in a theory of temporal cognition. The relevance of this can for instance be illustrated in relation to cognitive models of memory retrieval. Brown et al. (2007) have introduced a retrieval model they call SIMPLE (scale independent memory, perception, and learning):

„... memory traces can be seen as located and individuated at least partly in terms of their position along a temporal continuum receding from the present into the past. This time line is logarithmically compressed, such that recent locations are more easily discriminable from one another than are more temporally distant locations“ (p. 541).

As in SIMPLE, the current investigation has also identified a self who is looking back from the present moment along a mental time line to multiple temporal points (locations) in the past. Furthermore, the current investigation (see also Stocker, 2012a; Tulving, 1972, 2002) suggests that the

self at the present moment also mentally cognizes an *additional* (remembered) self in the past itself (in Figs. 1–4 this is always the self at the F₁-co-located PP, a distal distance away from the time line). In the current framework, it is this remembered embedded self that looks out at the actual past events. In addition, Stocker (2012b) has reviewed findings that suggest how this embedded distal self in the past can take on an embodied (field) or disembodied (observer) mental perspective. Future research could address the question, whether it might be fruitful for temporal-perspective-including models (like SIMPLE) to incorporate this „additional self“ in the past. This then would allow such models to investigate if this embedded self (i) cognizes the memory items in the past in a temporally direct or temporally indirect (prospective or retrospective) way and (ii) if it cognizes the items in an embodied (field) or disembodied (observer) perspective. Such refinements are likely to be relevant for a recall model. For instance: In field (embodied) memories one is known to retrieve richer accounts of affective reactions, physical sensations, and psychological states whereas in observer (disembodied) memories one is known to retrieve richer accounts of the external environment, such as where things were located in the remembered surroundings (e.g. McIsaac and Eich, 2002).

Acknowledgments

This research was supported by the Cogito Foundation, Wollerau, Switzerland (R-135/12).

References

- Addis, D. R., Pan, L., Vu, M. A., Laiser N., & Schacter, D. L. (2009). Constructive episodic simulation of the future and the past: Distinct subsystems of a core brain network mediate imagining and remembering. *Neuropsychologia*, 47, 2222–2238.
- Allen, J. F. (1984). Towards a general theory of action and time. *Artificial intelligence*, 23, 123–154.
- Bennett, M. & Partee, B. H. (1978). *Toward the logic of tense and aspect in English*. Indiana University Linguistics Club.
- Boroditsky L. (2000). Metaphoric structuring: Understanding time through spatial metaphors. *Cognition*, 75, 1–28.
- Brown, G. D., Neath, I., & Chater, N. (2007). A temporal ratio model of memory. *Psychological Review*, 114, 539–576.
- Casasanto, D., & Boroditsky, L. (2008). Time in the mind: Using space to think about time. *Cognition*, 106, 579–593.
- Comrie, B. (1985). *Tense*. Cambridge: Cambridge University Press.
- Declerck, R. (1986). From Reichenbach (1947) to Comrie (1985) and beyond: Towards a theory of tense. *Lingua*, 70, 305–364.
- Hartmann, M. & Mast, F. W. (2012) Moving along the mental time line influences the processing of future related words. *Consciousness and Cognition*, 21, 1558–1562.
- Jackendoff, R. (1987). The status of thematic relations in linguistic theory. *Linguistic Inquiry*, 18, 369–411.
- Jespersen, O. (1924) *The philosophy of grammar*. London: Allen & Unwin.
- Kowalski, R. & Sergot, M. (1986). A logic-based calculus of events. *New Generation Computing*, 4, 67–94.
- Lichtenstein, O. & Pfeiffer, A. (2000). Propositional temporal logics: Decidability and completeness. *Logic Journal of IGPL*, 8, 55–85.
- McIsaac, H. K. & Eich, E. (2002). Vantage point in episodic memory. *Psychonomic Bulletin & Review*, 9, 146–150.
- McGlone, M.S. & Harding, J. L. (1998). Back (or forward?) to the future: The role of perspective in temporal language comprehension. *Journal of Experimental Psychology: Learning, Memory, and Cognition*, 24, 1211–1223.
- Miles, L., Nind, L., & Macrae, C. (2010). Moving through time. *Psychological Science*, 21, 222–223.
- Montague, R. (1973). The proper treatment of quantification in ordinary English. In J. Hintikka, J. Moravcsik, & P. Suppes (Eds), *Approaches to natural language*. Dordrecht: Reidel.
- Núñez, R. E., Motz, B. A., & Teuscher, U. (2006). Time after time: The psychological reality of the ego- and time-reference-point distinction in metaphorical construals of time. *Metaphor and Symbol*, 21, 133–146.
- Núñez, R. E. & Sweetser, E. (2006). With the future behind them: Convergent evidence from Aymara language and gesture in the crosslinguistic comparison of spatial construals of time. *Cognitive Science*, 30, 401–450.
- Pendlebury, M. (1992). Elementary formal semantics for English tense and aspect. *Philosophical Papers*, 21, 215–241.
- Pinker, S. (1989). *Learnability and cognition: The acquisition of argument structure*. Cambridge, MA: MIT Press.
- Pinker, S. (2007). *The stuff of thought: Language as a window into human nature*. New York: Viking.
- Prior, A. N. (1967). *Past, present and future*. Oxford: Clarendon Press.
- Reichenbach, H. (1947). *Elements of symbolic logic*. New York: Collier-Macmillan.
- Schacter, D. L. & Addis, D. R. (2007). Constructive memory: The ghosts of past and future. *Nature*, 445, 27.
- Stocker, K. (2012a). The time machine in our mind. *Cognitive Science*, 36, 385–420.
- Stocker, K. (2012b). Toward an embodiment-disembodiment taxonomy. *Cognitive Processing*, 13, S347–S350.
- Talmy, L. (2000). *Toward a cognitive semantics. Vol. 1: Concept structuring systems*. Cambridge, MA: MIT Press.
- Tulving, E. (1972). Episodic and semantic memory. In E. Tulving & W. Donaldson (Eds.), *Organization of memory*. New York: Academic.
- Tulving, E. (2002). Episodic memory: From mind to brain. *Annual Review of Psychology*, 53, 1–25.
- Ulrich, R. & Maienborn, C. (2010). Left–right coding of past and future in language: The mental timeline during sentence processing. *Cognition*, 117, 126–138.