

Lawrence Berkeley National Laboratory

Lawrence Berkeley National Laboratory

Title

NITRIC OXIDE DETERMINATION BY A ZEEMAN-TUNED FREQUENCY-MODULATED ATOMIC LINE SOURCE

Permalink

<https://escholarship.org/uc/item/7406p7np>

Author

Koizumi, Hideaki

Publication Date

1979-03-01



Lawrence Berkeley Laboratory

UNIVERSITY OF CALIFORNIA

Engineering & Technical Services Division

Submitted to Analytical Chemistry

NITRIC OXIDE DETERMINATION BY A ZEEMAN-TUNED
FREQUENCY-MODULATED ATOMIC LINE SOURCE

Hideaki Koizumi, Tetsuo Hadeishi and Ralph D. McLaughlin

March 1979

RECEIVED
LAWRENCE
BERKELEY LABORATORY

MAR 14 1980

LIBRARY AND
DOCUMENTS SECTION

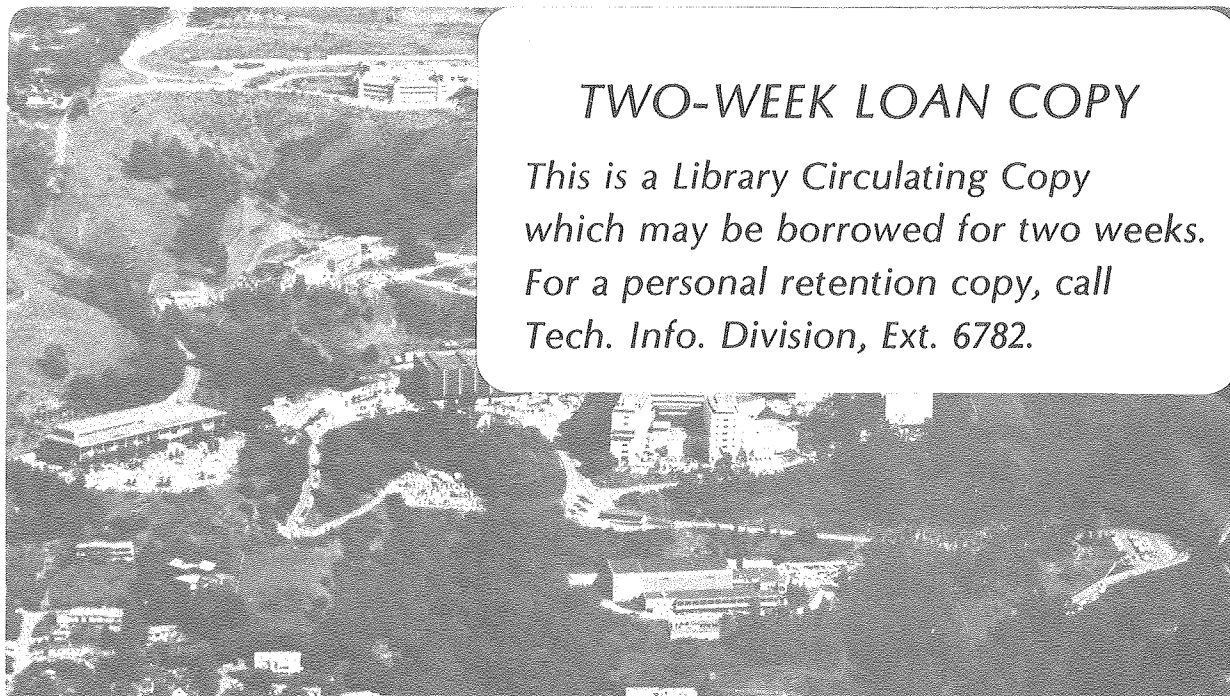

TWO-WEEK LOAN COPY

*This is a Library Circulating Copy
which may be borrowed for two weeks.
For a personal retention copy, call
Tech. Info. Division, Ext. 6782.*

LBL 10400 e2

DISCLAIMER

This document was prepared as an account of work sponsored by the United States Government. While this document is believed to contain correct information, neither the United States Government nor any agency thereof, nor the Regents of the University of California, nor any of their employees, makes any warranty, express or implied, or assumes any legal responsibility for the accuracy, completeness, or usefulness of any information, apparatus, product, or process disclosed, or represents that its use would not infringe privately owned rights. Reference herein to any specific commercial product, process, or service by its trade name, trademark, manufacturer, or otherwise, does not necessarily constitute or imply its endorsement, recommendation, or favoring by the United States Government or any agency thereof, or the Regents of the University of California. The views and opinions of authors expressed herein do not necessarily state or reflect those of the United States Government or any agency thereof or the Regents of the University of California.

NITRIC OXIDE DETERMINATION BY A ZEEMAN-TUNED
FREQUENCY-MODULATED ATOMIC LINE SOURCE⁺

Hideaki Koizumi,* Tetsuo Hadeishi and Ralph D. McLaughlin

Lawrence Berkeley Laboratory, University of California
Berkeley, CA 94720

+ This worked was prepared under the auspices of the Office of Health and Environmental research of the U.S. Department of Energy under Contract No. W-7405-ENG-48.

* Present address: Naka Works, Hitachi Ltd., Katsuta Ibaraki 312, Japan.

NITRIC OXIDE DETERMINATION BY A ZEEMAN-TUNED
FREQUENCY-MODULATED ATOMIC LINE SOURCE

Hideaki Koizumi,* Tetsuo Hadeishi and Ralph D. McLaughlin

Lawrence Berkeley Laboratory, University of California
Berkeley, CA 94720Abstract

Magnetically tuned emission lines from ions and atoms were utilized to determine concentrations of NO gas with high selectivity and high sensitivity. One of the Zeeman components of an emission line was shifted to exactly coincide with a single rotational-vibrational line of NO, whereas the other component was shifted away from the NO line. The coincident component indicated the extent of NO absorption and the noncoincident component measured the extent of background absorption. By making use of a differential measurement, light scattering and molecular absorption caused by coexisting small particles and gases were cancelled out. Detection limits of NO in N₂ were about 30 ppb and 150 ppb at low pressure and at atmospheric pressure, respectively.

*Present address: Naka Works, Hitachi Ltd., Katsuta Ibaraki 312, Japan.

Introduction

Nitric oxide is a necessary reagent in the photochemical reactions that are responsible for smog formation caused by emission of automobile and plant exhausts into the atmosphere. In situ detection of NO in flames is an important tool for combustion diagnostic research programs that may be important in the control of emissions. Traditionally, the detection of NO has been accomplished by oxidation to NO₂ followed by absorption into a solution containing a colorimetric reagent (1). In addition, infrared absorption spectrometry has been used. However, these techniques severely suffer from interferences caused by large concentrations of coexistent gases and do not have the capability for in situ measurements or, in the case of infrared spectroscopy, do not have the sensitivity for in situ measurement.

Because of the need for highly sensitive and accurate determinations of NO, several new techniques have been developed. These include Laser Magnetic Resonance using a H₂O far-infrared laser (2-4), Zeeman-modulated infrared absorption using a CO laser (5), infrared optoacoustic spectroscopy with a CO laser (6) and UV absorption using a field modulated NO light source (7).

In general, because of the differences in the values of the oscillator strengths for transitions, a measurement that depends on an electronic transition of a molecule will be more sensitive than one that depends on a vibrational-rotational transition in the infrared (IR) or far infrared (FIR) spectral region. The sensitivity of photodetectors is also better in the UV region than in the IR region. However, the spectrum due to electronic vibrational-rotational transitions in the UV is much more complicated and less selective than vibrational-rotational IR

or rotational FIR transitions. In the vast majority of cases, the rotational structures can be resolved in the IR and FIR spectrum, but not in the UV spectrum except for the case of small molecules (8). Even for small molecules, high resolution (~50,000) is required for the observation of rotational structure. Since the sharp structure that is necessary for high specificity is difficult to observe, UV spectroscopy has not been used as frequently as IR spectroscopy for the analysis of contaminants that coexist with other kinds of molecules.

Recently, we have developed a new technique for NO determination by utilizing UV absorption of a magnetically tuned and frequency modulated atomic line source. This method allows high resolution spectra to be obtained without the difficulties associated with the use of a high resolution spectrograph. In this technique, one of the Zeeman components of the emission line is exactly tuned to coincide with a single rotational-vibrational line of NO while the other component is shifted away from the NO line. The matching component indicates the extent of NO plus background absorption and the unmatching component indicates background absorption only. A differential measurement is made of the intensity of these two components. In addition to being highly specific, this technique is capable of high sensitivity because the oscillator strengths of electronic transitions in the UV, VUV and visible regions are much larger than these for vibrational-rotational transitions in the IR and FIR regions. Furthermore, the true absorption coefficients of NO electronic transition have been shown to be several hundred times larger than values obtained from low resolution measurements (9). By using an exactly tuned very narrow atomic line, the high sensitivity predicted by the true absorption coefficient can be obtained. It could not be possible to obtain the high signal to noise ratio continuous source like

a usual D_2 lamp because the light intensity over the small spectral interval of a few GHz is too low. This is the same situation as exists in the field of atomic absorption spectroscopy where neither high sensitivity nor good linearity can be obtained by D_2 and Xe lamps because of the relatively broad band pass of the detection monochromator.

In a vast majority of cases, this technique does not suffer from interference because of absorption and light scatterings caused by coexistent large molecules and small particles in the absorption region. This is true because the absorption due to electronic transitions of polyatomic molecules is almost always constant over a spectral region of a few GHz and hence there is no difference in absorption between the two Zeeman components. Reasons why continuous absorption is associated with electronic transitions in polyatomic molecules are discussed by Hertzberg (8). Because of high moments of inertia, predissociation is likely, which results in line broadening. Also, there are many allowed transitions which increase the likelihood of overlap which results in continuous spectra. Even a simple IR spectrum may not predict a simple UV spectrum because the rotational constants may differ greatly between the upper and lower state. Furthermore, even if another molecule in the sample displayed rotational structure, it would be very unlikely that a component magnetically tuned to the NO line would also overlap the rotational line of the other molecules. Since the two components are equally diminished by Rayleigh and Mie scattering caused by molecules and small particles, no differential signal is produced because of these effects. Therefore, this approach should be very powerful for in situ analysis of NO in samples containing smoke, or a mixture of various kinds of gases.

Experimental Design

Experimental instruments and parameters are listed in Table I. A block diagram of the system is shown in Fig. 1. Figure 2 shows the construction of the light source. This light source is a modification of a magnetically confined arc lamp, described by Hadeishi, et al (10). The pole pieces were made of permendur and the chamber of stainless steel. Ar gas flowed through the light source at a pressure of 2-5 Torr. The cathode was made of a metal or compound that would yield the desired spectrum. To obtain a Zn spectrum, brass was used. To get Cd ion and atomic spectra, CdO powder was packed in a hole in the cathode (diameter: 3mm). When Cd hyperfine structure caused problems, a single isotope (^{114}CdO , ^{114}Cd : 99, prepared by Oak Ridge National Laboratory) was used. The anode was surrounded by an insulator to minimize the likelihood of discharge to the wall. Both D.C. and R.F. power were applied to the light source simultaneously (as Koizumi, et al reported, 11). The R.F. power reduced the discharge voltage by a factor of ten, increased the stability of the discharge in the high magnetic field and decreased self absorption. The gas temperature of the discharge was directly measured utilizing a small thermocouple insulated by a thin ceramic coating. The gas temperature changed from 150° to 250° with the D.C. power, R.F. power, gas pressure and gas flow within the ranges shown in Table I. Under the mostly used condition, the gas temperature was 198°.

The pole pieces were welded to the discharge chamber (Fig. 2). A hole in the magnet through the pole piece and a yoke allowed the radiation to be observed in a direction parallel to the magnetic field. A small condenser lens was placed in the pole piece to increase the amount of light escaping from the chamber. A new type of half-wavelength plate was developed for this experiment. It consisted of a fused quartz

block that was under pressure because of the action of a vise on a strong spring. The applied pressure caused an optoelastic effect and produced a retardation of the phase of the light. The amount of retardation is proportional to the applied pressure. Half wavelength retardation was observed by using crossed polarizers, and quarter wavelength retardation was observed by using a quartz Fresnel rhomb. A linear polarizer was fixed on the shaft of a synchronous motor. Light from a direction parallel to the magnetic field was allowed to pass through a hole made through the shaft of the motor. Then, the right handed and left handed circularly polarized emission from the light source were alternately observed with the rotation of the polarizer.

Figure 3 shows the oscilloscope traces for signals from the pre-amplifier (upper traces) and from the synchronous rectifier (lower traces). The natural Cd (II) line at 214.4 nm was used in this case. With this line only one Zeeman component coincides with the NO line of $Q=10.5$. As the polarizer rotates first the σ^- component passes through the absorption cell and is absorbed by NO. As the rotation continues the σ^+ component then passes through the absorption cell but is not absorbed by NO. In a vast majority of cases, the intensity of σ^+ and σ^- components is equally diminished by absorption due to other molecules or by light scattering. It follows that a sine shaped signal is observed if NO exists in the absorption cell. The frequency of this signal will correspond to the frequency of rotation of the motor. The differential absorption between σ^+ and σ^- components results in a output signal from the synchronous rectifier. Since the rotation speed of the polarizer is 3600 r.p.m., the signal can follow rapid changes in NO density and can correct for rapidly changing background absorption. The signal from the synchronous rectifier was recorded on the chart with a time constant of 0.5 sec.

A differential type pressure gauge with the accuracy of ± 0.2 Torr. was used to measure the pressure in the absorption cell in the pressure range between 0.5 - 110 Torr. High pressure and high purity NO and NO-N₂ mixtures were stored in a reservoir made of monel metal. Gases were carried into the absorption cell by evacuating the system.

Results and Discussion

As shown in Fig. 4a, NO exhibits sharp γ bands in the UV spectral region. The transition corresponding the γ band is $A^2_{\pi} - X_2$. The NO γ bands were studied by a number of researchers (12-19). Under high resolution, the vibrational lines in Fig. 4a exhibit a number of narrow rotational lines, which have also been assigned (12-13). Even at N₂ pressures of one atmosphere, the rotational structure of these NO bands appears sharp (14). It is because these rotational lines are so very sharp that it has been difficult to obtain high sensitivity by making a UV absorption measurement using a continuum source. Figure 4a shows the absorption spectrum of NO bands obtained by using a D₂ lamp and a monochromator with a resolving power of 0.1 nm. Figure 4b shows rotational lines in the R₁ branch of the (1,0) (vibrational) transition that are contained in the 214 nm band. These wavelengths were taken from the literature (13) and the intensity was calculated from the Boltzman distribution of the X₂ 1/2 ground state at room temperature. The Doppler half intensity width of the individual rotational lines is 2 GHz at 300 K. For NO measurements, one of the Zeeman components of an atomic line is made to coincide with one of the rotational-vibrational lines of NO while the other Zeeman component is shifted away from the rotational-vibrational line.

Accidental near coincidence between rotational-vibrational lines and atomic lines have been used by several researchers to excite a single level of the NO γ bands. Cadmium ion lines at 204.9, 214.4 and 226.5 nm were used to excite (2', 0"), (1', 0") and (0', 0") transitions of NO, respectively (14-18). Recently, Melton, et al also reported many atomic line coincidences in the study of energy transfer in monochromatically excited NO (19). We selected several emission lines to use for the present study. Cadmium ion lines at 214.438 nm and 226.502 nm and Zn line at 213.856 nm were selected in this experiment because they have simple Zeeman patterns and high intensity. Energy level diagrams for NO, showing the transition that nearly coincide with these ion and atomic lines, are shown in Fig. 5. v , K and J refer to the vibrational quantum number, rotational quantum number and the vector sum of the rotational and spin quantum numbers, respectively.

Naturally occurring Cd consists of a large number of stable isotopes. ^{111}Cd (12.75 %) and ^{113}Cd (12.26 %) have the nuclear spin of 1/2. Although the resonance line 228.8 nm shows only a very small splitting, the ion lines at 214.4 and 226.5 nm show a fairly large effect (20). The separation of the components due to the odd isotopes in the 214.4 nm line is $0.519 \pm 0.004 \text{ cm}^{-1}$ ($15.57 \pm 0.12 \text{ GHz}$), and in the 226.5 nm line the separation is $0.491 \pm 0.007 \text{ cm}^{-1}$ ($14.73 \pm 0.21 \text{ GHz}$). To avoid the effects of the hyperfine structure, a single isotope, ^{114}Cd , was used in the basic studies of this technique.

Naturally occurring zinc also contains several isotopes. However, the width of the 213.9 nm line due to hyperfine structure is only about 1 GHz (21). The only isotope with nuclear spin is ^{67}Zn and its abundance is only 4.11 %. Therefore, it is not necessary to use a single isotope of Zn in this experiment. Figure 6, which we shall discuss

later, explains the concept of the present technique and shows the relation between the σ^+ and the σ^- Zeeman components and rotational-vibrational lines of NO. The terms of the upper and the lower states for the atomic lines are listed in Table II. Only the ^{114}Cd (II) line at 214.4 nm (Fig. 6a) has two components of the same circular polarization. The other lines have a single σ component of each circular polarization. As shown in Fig. 6, one σ component matching a NO line is used for the measurement of NO absorption while the other component is used to determine the background absorption. In this case, the separation between the σ^+ and the σ^- components is around 2 cm^{-1} (60 GHz, 0.0092 at 214.4 nm).

In order to determine the conditions for maximum sensitivity, the magnetic field strength, giving the maximum differential absorption between the σ^+ and the σ^- components, was measured for the two ion lines and the atomic line.

Figure 7 shows the relation between the strength of the magnetic field applied to the light source and the difference of intensity between the σ^+ and σ^- components for the Cd (II) line at 214.4 nm. A minor peak in the curve was observed at a field strength of 5.3 kG because of the presence of two components of the same circular polarization when the single isotope ^{114}Cd was used. When natural Cd was used, the minor peak disappeared because the emission line was broadened by the hyperfine structure. A higher sensitivity could be obtained using the single isotope because the emission line is as sharp as the NO absorption line. The highest sensitivity was obtained at 9.2 kG. This measurement was carried out at low pressure so the NO absorption line was very narrow.

Figure 8 shows the relation between the field strength and the intensity of differential absorption for the Zn line at 213.9 nm. There is

only one σ component of the same circular polarization in this line. The curve in Fig. 8 contains information that would allow the profile of the vibrational rotational NO line to be calculated by correcting for the 1.6 GHz width of the emission line. The highest sensitivity in this case was obtained at the field strength of 20 kG.

These figures also demonstrate the selectivity of this technique. Since the splitting of the Zeeman components is so small, it is highly probable that the background absorption will be constant over this spectral region. If other molecules in the sample show sharp rotational structure, it is highly improbable these lines will coincide with the NO line. For the Cd line at 226.5 nm, the maximum differential absorption was obtained at a field strength of 16.5 kG. The magnetic field strengths giving the maximum difference in absorption between the σ^+ and σ^- components for all the lines are listed in Table II. For routine analysis at near room temperature, the Cd line at 214.4 nm would be the best to use because it does not require high magnetic field. However, for measurement at high temperatures, the Zn line at 213.9 nm should be used because the population of the $J = 29.5$ level as determined by the Boltzmann distribution becomes maximum at 3994°C. In this situation, this line would result in a higher sensitivity than the Cd 214.4 nm line since the population of the $J = 12.5$ level would decrease. Hence, the Zn line should be used for measurement in flames or other combustion systems.

Figure 9 shows one example of NO signals obtained with a 20 cm cell. The lower trace shows the differential absorption between the σ^+ and σ^- components in absorbance units and the upper trace shows the average transmittance of the σ^+ and σ^- components through the cell. In this experiment, the noise level of the base line corresponded to about 4.5×10^{-4} absorbance units. Nitric oxide at the 5 ppm level causes a signal

of 0.025 absorbance units. The detection limit is usually defined by the quantity of NO giving rise to a signal twice as large as the noise level. Using this criterion, the lower limit of detection is 180 ppb with the present technique. We also used a 120 cm cell. By putting a lens in the cell, the noise level was almost the same as that with the 20 cm cell. In this case, the detection limit was about 30 ppb. Higher sensitivity could be obtained by using a long path cell such as is used in IR spectroscopy because the Cd line can be made very intense.

Figure 10 illustrates the capability of this technique to correct for other molecules in the absorption region. The lower trace show the differential absorption between the σ^+ and σ^- components in absorbance units and the upper trace the average absorption of the σ^+ and σ^- components in transmittance units. The scale is the same as that of Fig. 9. Acetic acid vapor and nitro-benzene vapor were introduced into the absorption cell because both of these compounds have strong absorption bands near the Cd line at 214.4 nm. This indicates that when the absorption from non-NO species is as high as 70%, good measurements can still be made.

If oxygen is present, at room temperature, NO will react to form NO₂. Since this compound does not produce a differential absorption signal, it is possible to measure the change of NO concentration when air is introduced into the cell. The reaction $2\text{NO} + \text{O}_2 \rightarrow 2\text{NO}_2$ proceeds with a reaction rate proportional to the square of NO concentration, and hence is very slow when the NO concentration is a few ppm (22).

It is difficult to use the fluorescence from NO as a detection method because of quenching by O₂, H₂O, etc. The quenching half pressures of O₂ and H₂O are 1.1 Torr and 0.65 Torr, respectively (23). Hence, NO fluorescence cannot be used to detect NO in the atmosphere. Using the

present Zeeman technique, however, atmosphere measurement of NO is possible, though, of course, the NO concentration changes by the reaction with O_2 .

It was also observed that a surface reaction will rapidly reduce the NO concentration at high temperature when a stainless steel cell was used instead of a quartz cell. The NO concentration rapidly decreased at temperatures about $79^\circ C$, even when there was no oxygen in the cell.

The NO signal depends upon the pressure of a foreign gas. The emission line width of Cd or Zn is less than 3 GHz, which is determined by the gas temperature of the plasma. The pressure broadening of the emission line is negligibly small because the Ar gas pressure is only a few Torr. The effective cross section for the Lorentz broadening of NO is relatively large. The line width becomes larger than 10 GHz at a foreign gas pressure of 1 atm, whereas it is only 2 GHz at less than 10 Torr at room temperature (24). Therefore, the sensitivity decreases with the foreign gas pressure. Figure 11 shows the relationship between NO absorption and the pressure of N_2 . The intensity of NO absorption in N_2 at 1 atm is about one-fourth of that in N_2 at 10 Torr. It is also possible to obtain the pressure dependence of NO absorption when O_2 was the foreign gas. The reaction of NO with O_2 was very slow because the NO concentration was only 20 ppm. The relation between the O_2 pressure and the differential signal was almost the same as that when N_2 was used. Although the signal strength varies with a big change of foreign gas pressure, it should be emphasized that the differential absorption is completely free from the quenching effects that make fluorescent measurements so difficult. The present technique is also applicable to the determination of SO_2 , NO_2 and HCHO. It will be reported in the near future.

References

- (1) A.C. Stern, Ed., "Air Pollution," Vol. 3, Chap. 7, Academic Press, New York, 3rd edition (1976).
- (2) M. Mizushima, K.M. Evenson and J.S. Wells, Phys. Rev., A, 5, 2276 (1972).
- (3) P.A. Bonczyk, Chem. Phys. Lett., 18, 147 (1973).
- (4) S.M. Freund, J.T. Hougen and W.J. Lafferty, Can. J. Phys., 53, 1929 (1975).
- (5) A. Kaldor, W.B. Olson, A.G. Maki, Science, 176, 508 (1972).
- (6) L.B. Kreuzer and C.K.N. Patel, Science, 173, 45 (1971).
- (7) T.T. Kikuchi, Appl. Opt., 13, 329 (1974).
- (8) G. Herzberg, "Molecular Spectra and Molecular Structure, II. Spectra of Diatomic Molecules, III. Electronic Spectra and Electronic Structure of Polyatomic Molecules," Van Nostrand Reinhold Co., New York (1966).
- (9) H. Okabe, "Photochemistry of Small Molecules," Wiley Inter Science, Somerset, NJ (1978).
- (10) T. Hadeishi and T. Anderson, Opt. Com., 23, 252 (1977).
- (11) H. Koizumi and K. Yasuda, Spectrochim. Acta, 31B, 237 (1976).
- (12) L. Gero and R. Schmid, Proc. Phys. Soc., London, 60, 533 (1948).
- (13) R. Engleman, Jr., P.E. Rouse, H.M. Peek and V.D. Baiamonte, Los Alamos Scientific Laboratory Report LA-4364 (1970).
- (14) A.G. Gaydon and A.R. Fairbairn, Proc. Phys. Soc., A67, 474 (1954).
- (15) O.R. Wulf, Phys. Rev., 46, 316 (1934).
- (16) G.E. Moore, O.R. Wulf and R.M. Badger, J. Chem. Phys., 21, 2091 (1953).

- (17) A.B. Kreuhzeps, Onmuka U Cnekmpocknie, 1, 469 (1956).
- (18) H.P. Broida and T. Carrington, J. Chem. Phys., 38, 136 (1963).
- (19) L.A. Melton and W. Klemperer, J. Chem. Phys., 59, 1099 (1973).
- (20) F.M. Kelly and J.B. Sutherland, Can. J. Phys., 34, 521 (1956).
- (21) M.F. Crawford, W.M. Gray, F.M. Kelly and A.L. Schawlow, Can. J. Res., 28, 138 (1950).
- (22) J. Heicklen and N. Cohen, "The Role of Nitric Oxide in Photochemistry," Advance in Photochemistry, Vol. 5, P 157, Interscience Publishers, New York (1968).
- (23) F.P. Schwarz and H. Okabe, Anal. Chem., 47, 703 (1975).
- (24) H. Koizumi, T. Hadeishi and R.D. McLaughlin: unpublished work.

This work was performed under the auspices of the U.S. Department of Energy under Contract No. W-7405-ENG-48.

TABLE I. Experimental apparatus and parameters.

Light Source	DC-HF magnetically confined arc lamp (10) (11) D.C.: 50-200V, 50-150mA HF: 70 MHz, 10W Ar gas pressure: 2-5 Torr, flow rate: 0.1 L/min at 1 atm
Electromagnet	Varian Associates Model V-4004,
Quarter wave plate	Photoelastic variable retarder 25 x 12.5 x 12.5 mm suprasil, stress: 0-100 kg
Polarizer	Rochon prism (Ohyokohden Laboratory Co.), artificial quartz crystals with optical contact.
Rotator	Hollows shaft synchronous motor, hole diameter: 7 mm 3600 r.p.m.
Monochromator	J-Y Optical Systems, Model H-20 UV-V, Aperture F:4.2, dispersion: 4 nm/mm
Photomultiplier	Hamamatsu TV, R955
Thermometer	Doric Digital Trendicator 400 Type K/°C (iron constantan thermocouple)
Log. amplifier	Analog Devices, 755N
Lock-in amplifier	120 Hz Q=25, t=1 sec.
NO gas	Matheson Gas Products Co., Pure NO, 450 ppm NO in N ₂ , 0.70 ppm NO in N ₂ (<0.20 ppm)
Pressure Gauge	Hasting Vacuum Gauge (thermocouple): 10 ⁻³ to 5 Torr, Wallace and Tierman Model FA-141 (differenetial diaphragm gauge): 0.5 to 110 Torr, U.S. Gauge (diaphragm gauge): 25 to 760 Torr
Vacumm pump	The Welch Scientific Co., Duo Seal Vacuum Pump, 17 L/min.

TABLE II. Comparison of atomic lines with near-coincident molecular lines

Atomic (ion) line	Wavelength (nm)	Transition	Rotational line, J	Observed separation (GHz)	Field strength for matching (kg)
Cd(II)	214.438	$2S_{1/2}-2P_{3/2}$	$R_1(12-1/2)$	-12.5	9.2
Cd(II)	226.502	$2S_{1/2}-2P_{1/2}$	$Q_2(10-1/2)$	-30.8	16.5
Zn	213.856	$1S_0-1P_1$	$Q_1(29-1/2)$	28.0	20.0

Figure Captions

- Fig. 1. Block diagram of the experimental apparatus.
- Fig. 2. Magnetically confined arc lamp.
- Fig. 3. Oscilloscope traces of the signal from the photomultiplier and from the synchronous rectifier.
- Fig. 4. a) Absorption spectrum of NO γ bands 1870 ppm in N₂ 1 atm., 10 cm cell.
b) The rotational-vibrational lines designated by J values in the R₁ branch due to the (1,0) vibrational transition of the NO γ band, at 300K.
- Fig. 5. NO energy level diagrams showing those transitions that nearly coincide with the atomic and ion lines used in this study.
- Fig. 6. The concept of the present technique and relationship between the rotational-vibrational line of NO and the Zeeman split atomic line.
- Fig. 7. Relation between the magnetic field strength and the differential absorption caused by NO for the Cd (II) line at 214.4 nm.
- Fig. 8. Relationship between the field strength and the differential absorption caused by NO for the Zn line at 213.9.
- Fig. 9. NO signal with the present technique. Lower trace: differential signal; upper trace: transmittance of light through the cell.
- Fig. 10. Correction for light scattering and absorption by other molecules. Lower trace: differential signal; upper trace: transmission through the cell in absorbance unit.
- Fig. 11. Relation between the differential absorption signal of NO and the pressure of the coexisting N₂ gas.

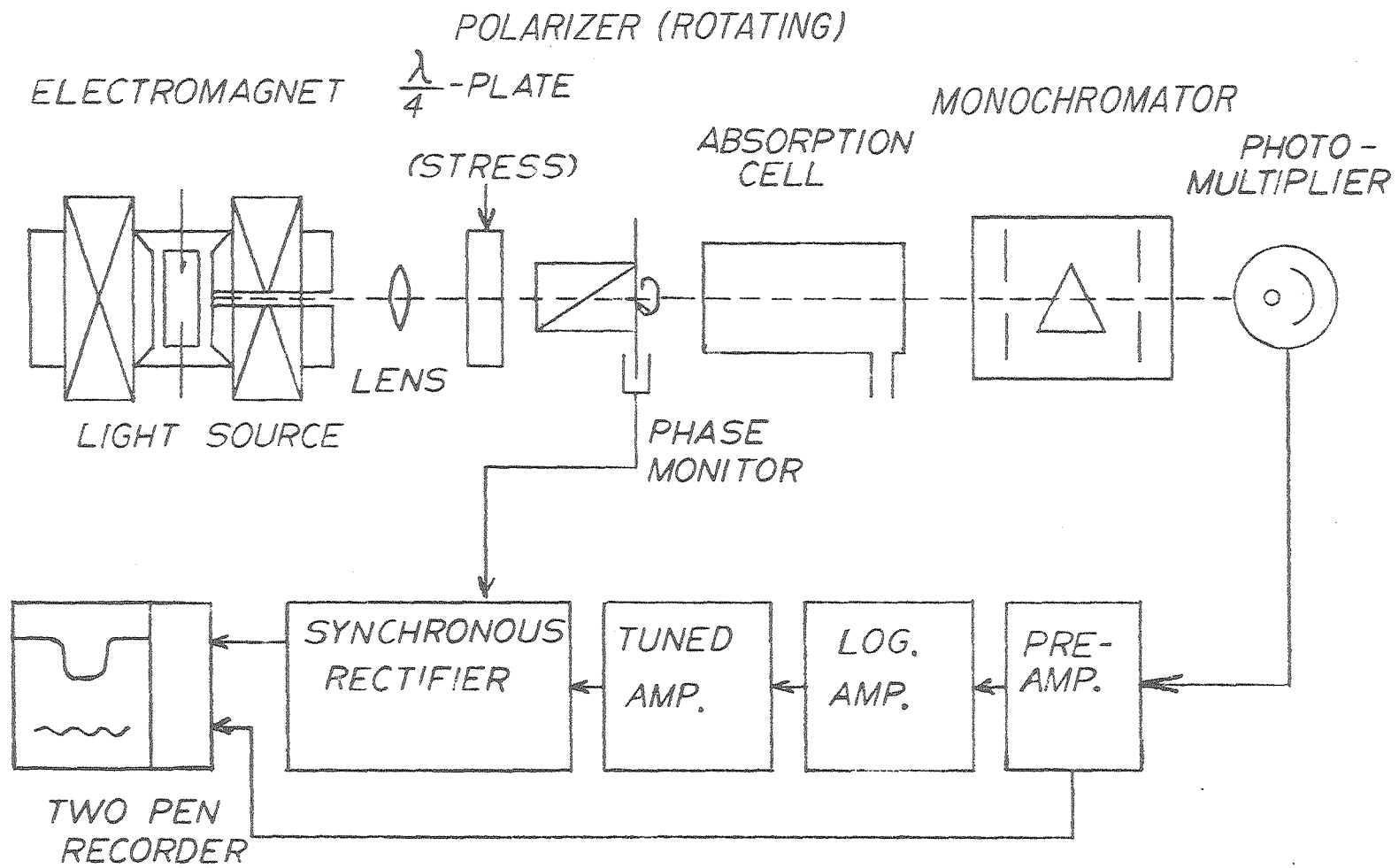
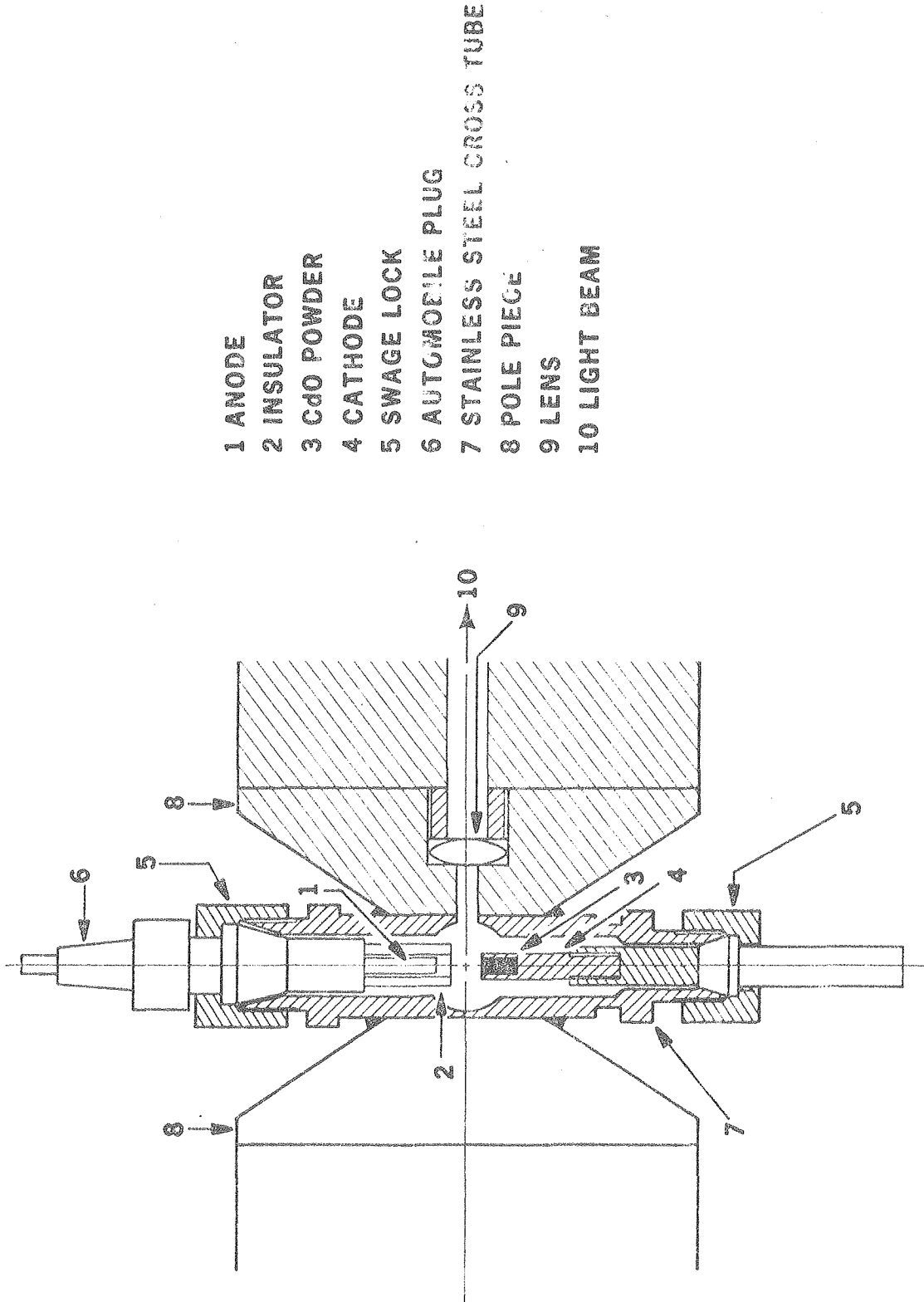

Fig. 1

XBL 789-10688A



- 1 ANODE
- 2 INSULATOR
- 3 CdO POWDER
- 4 CATHODE
- 5 SWAGE LOCK
- 6 AUTOMOBILE PLUG
- 7 STAINLESS STEEL CROSS TUBE
- 8 POLE PIECE
- 9 LENS
- 10 LIGHT BEAM

XBL 795-1603B

Fig. 2

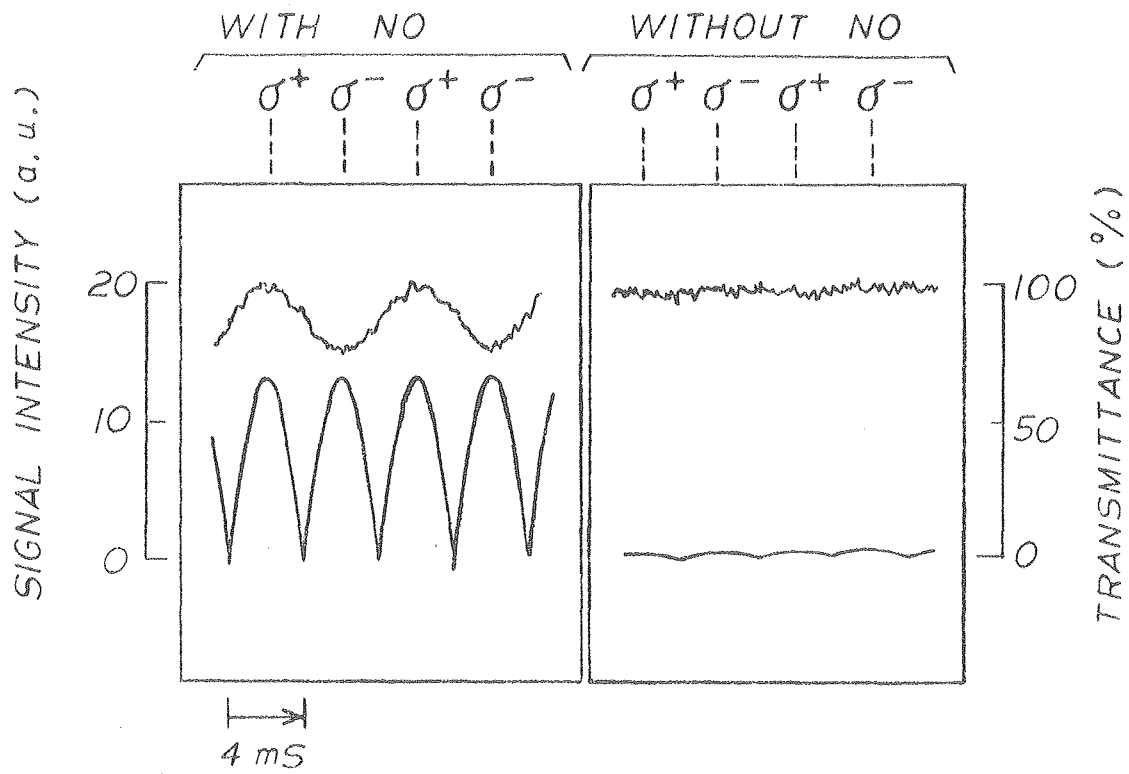

XBL 789-10689

Fig. 3

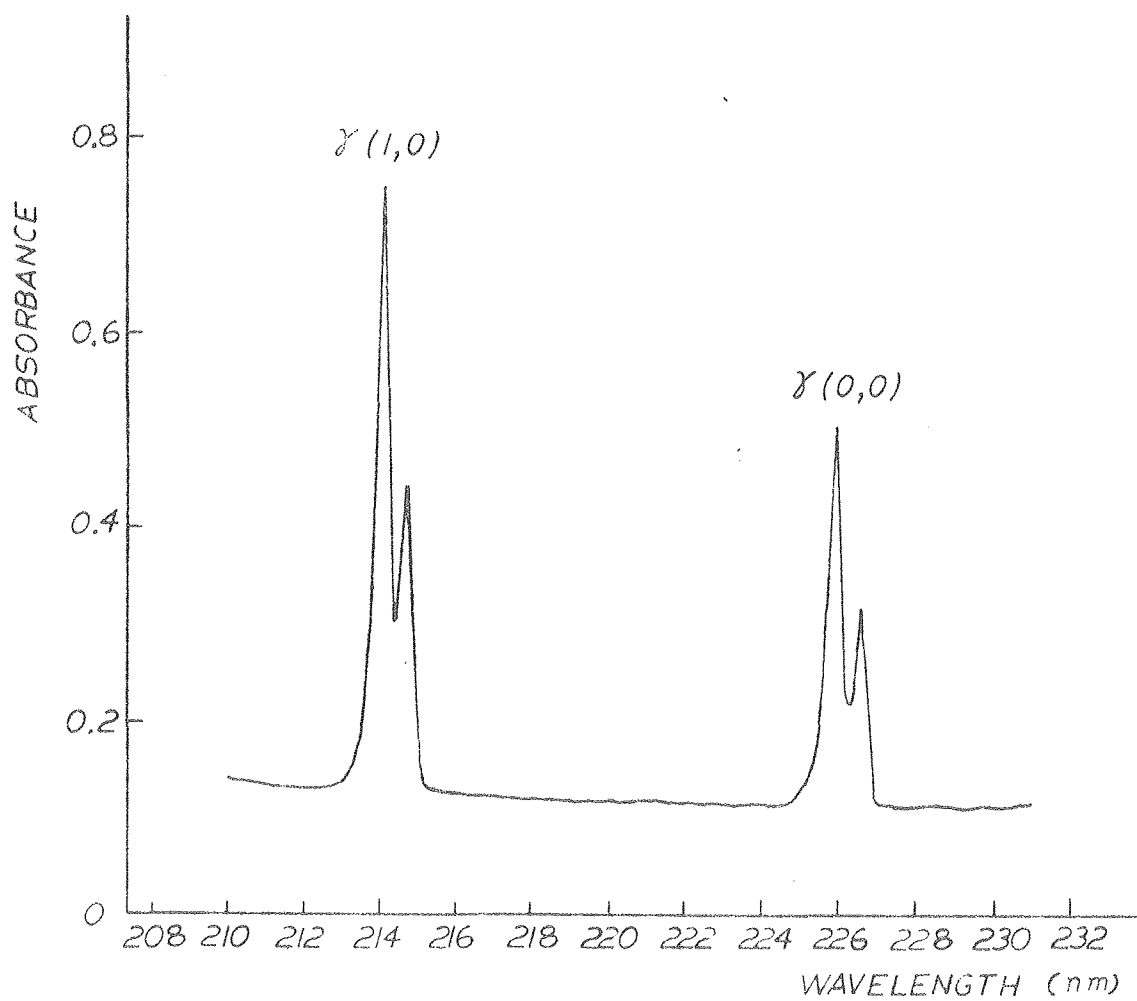

XBL 789-10690A

Fig. 4a

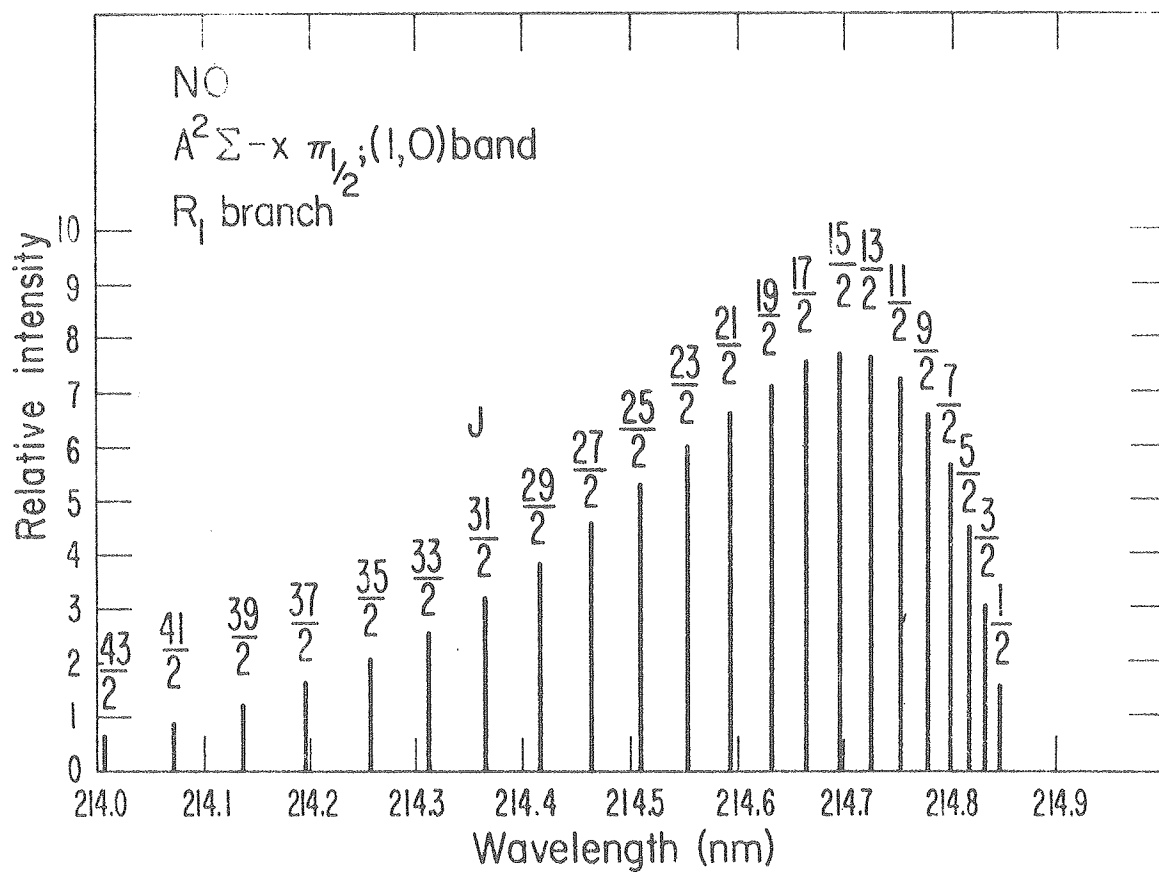

XBL 795-1607A

Fig. 4b

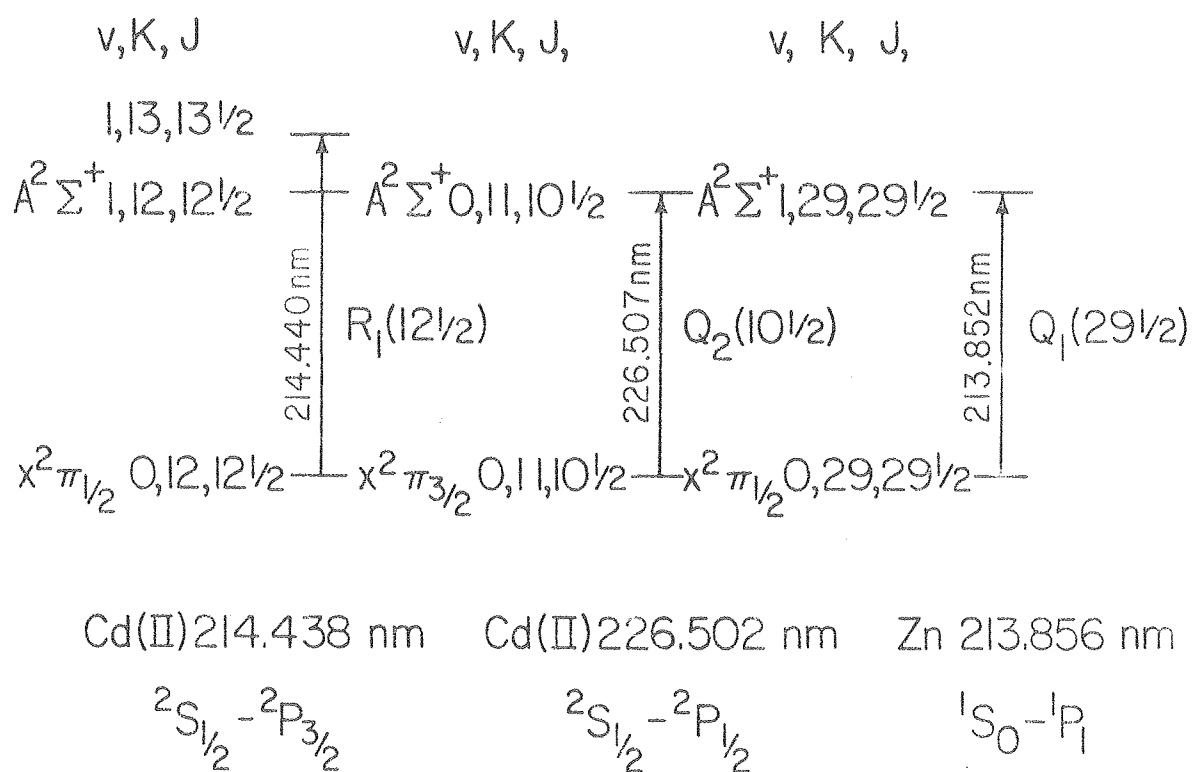

XBL 795-1604 A

Fig. 5

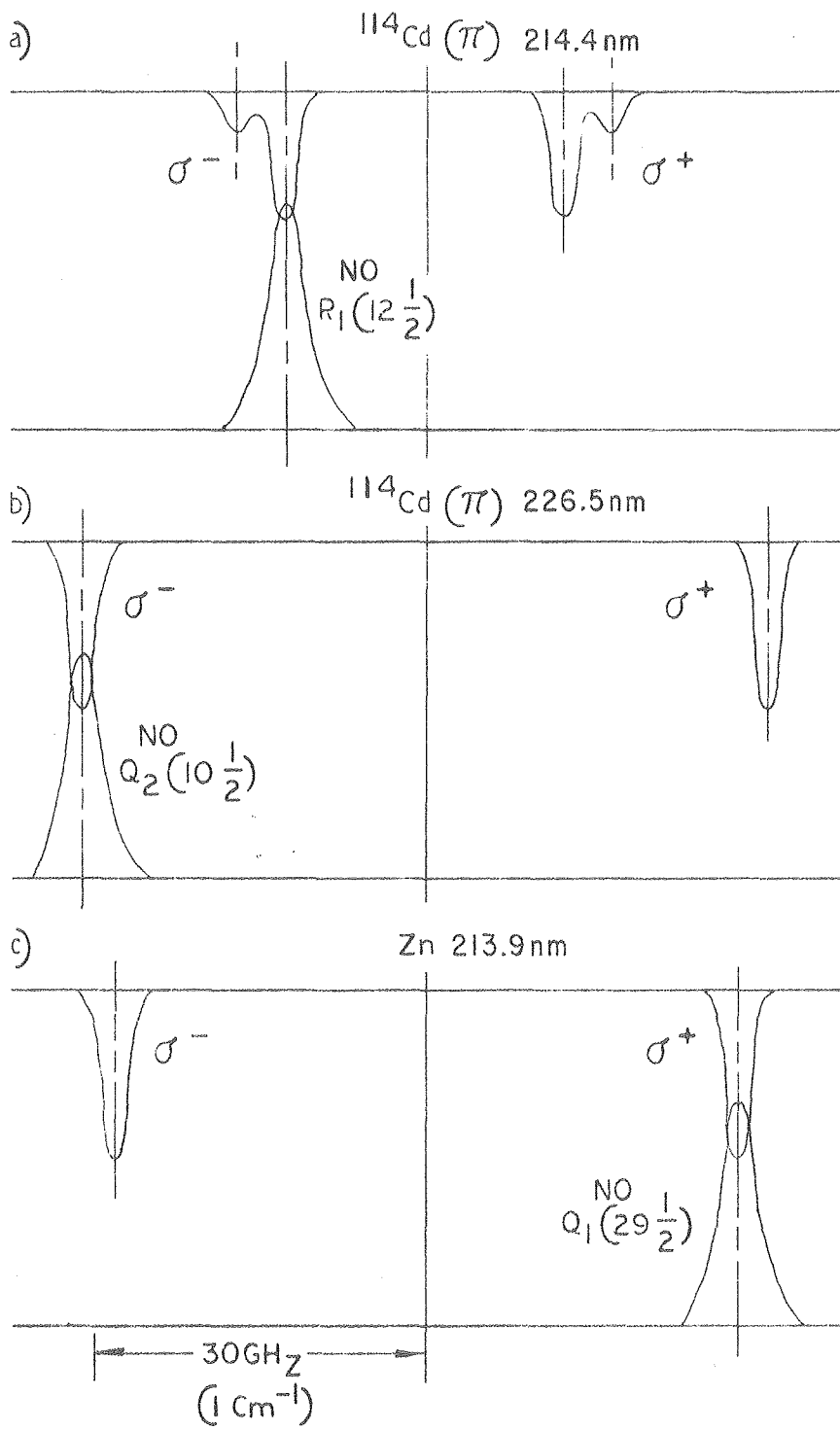

XBL 789-10687A

Fig. 6

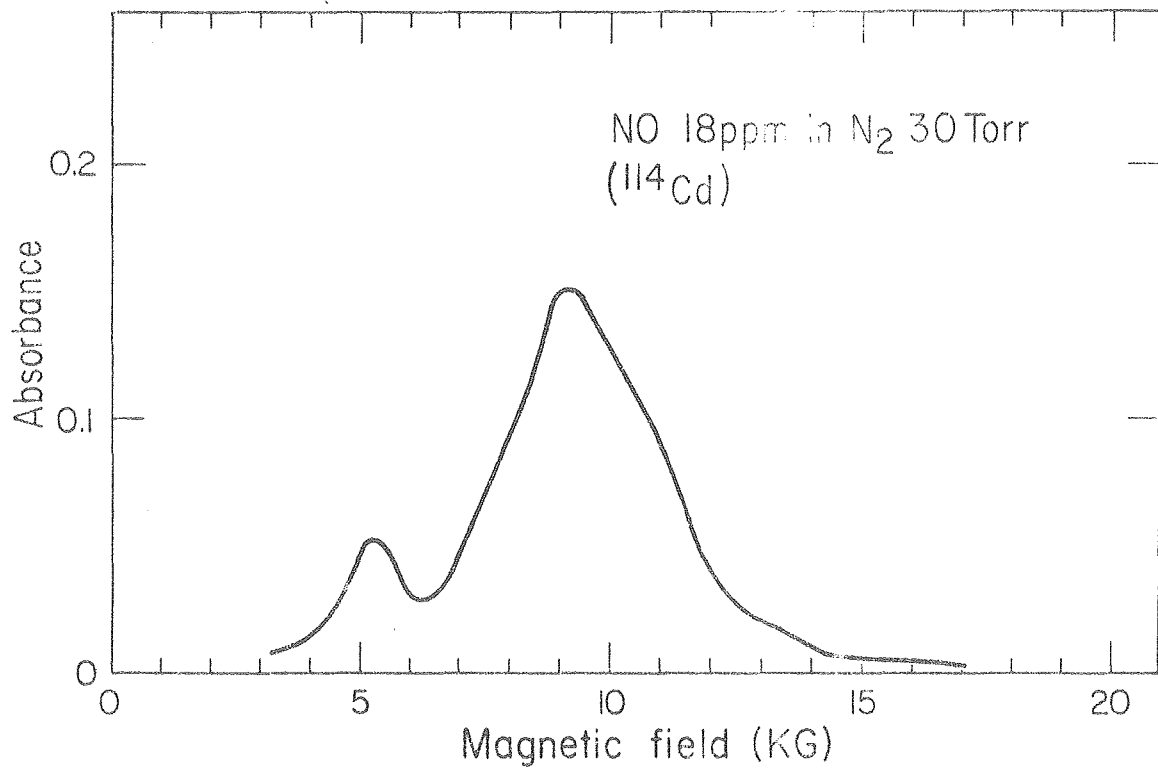

XBL 795-1605A

Fig. 7

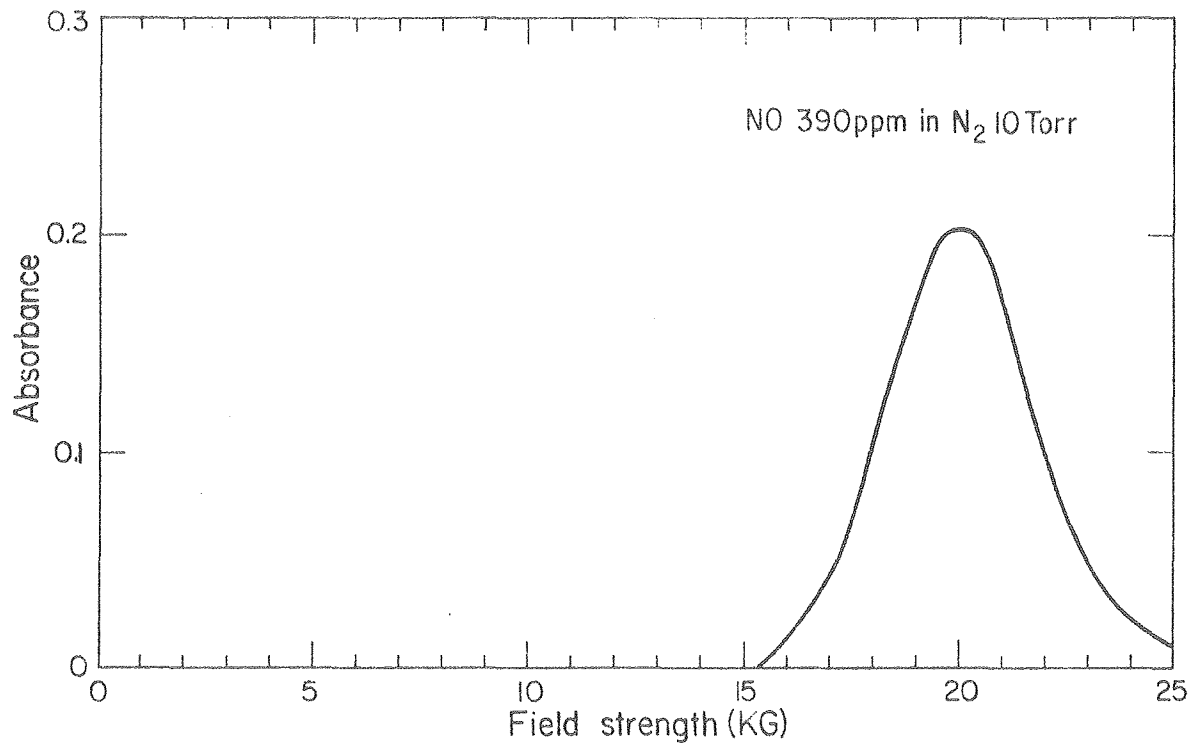

XBL 795-1606 A

Fig. 8

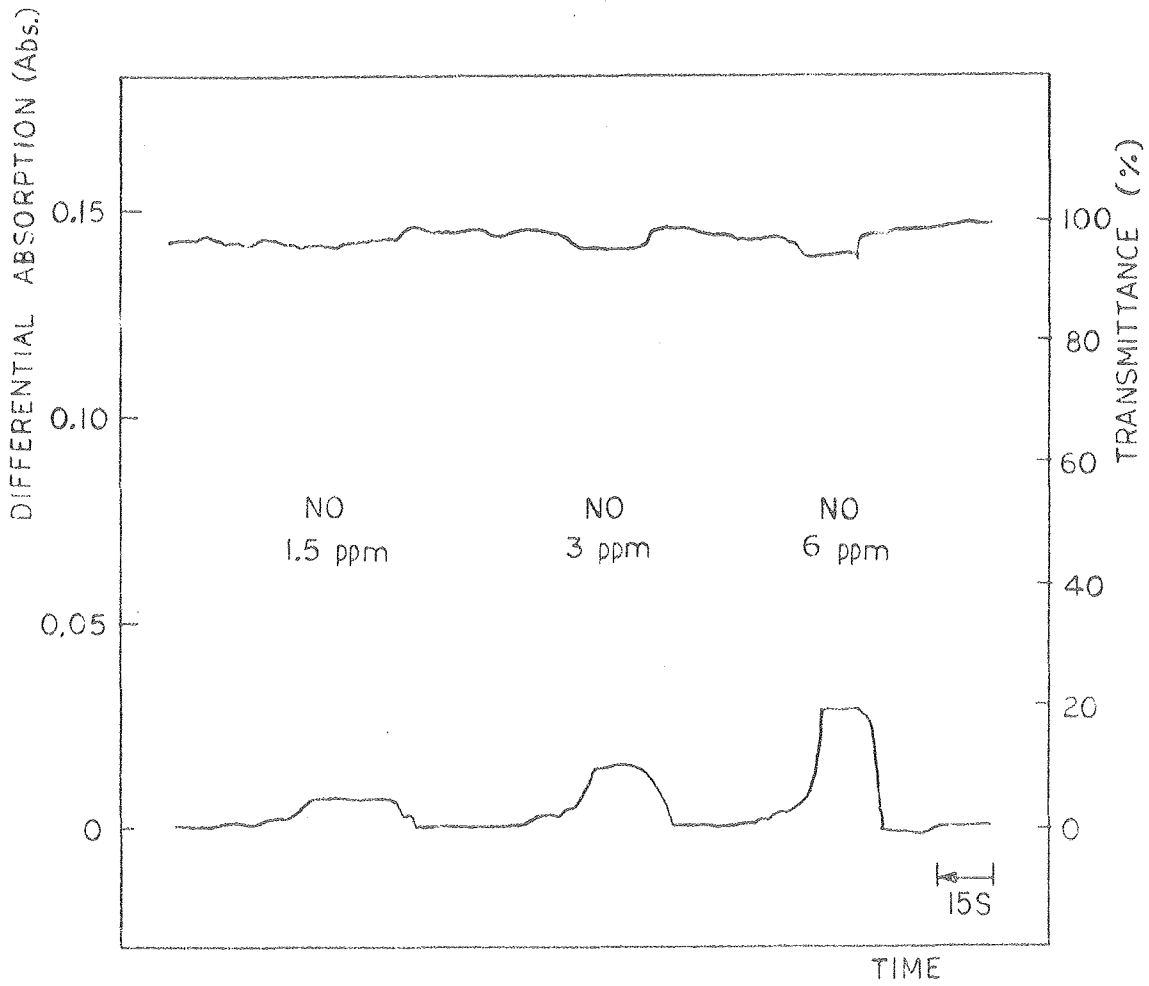

XBL 789-10678A

Fig. 9

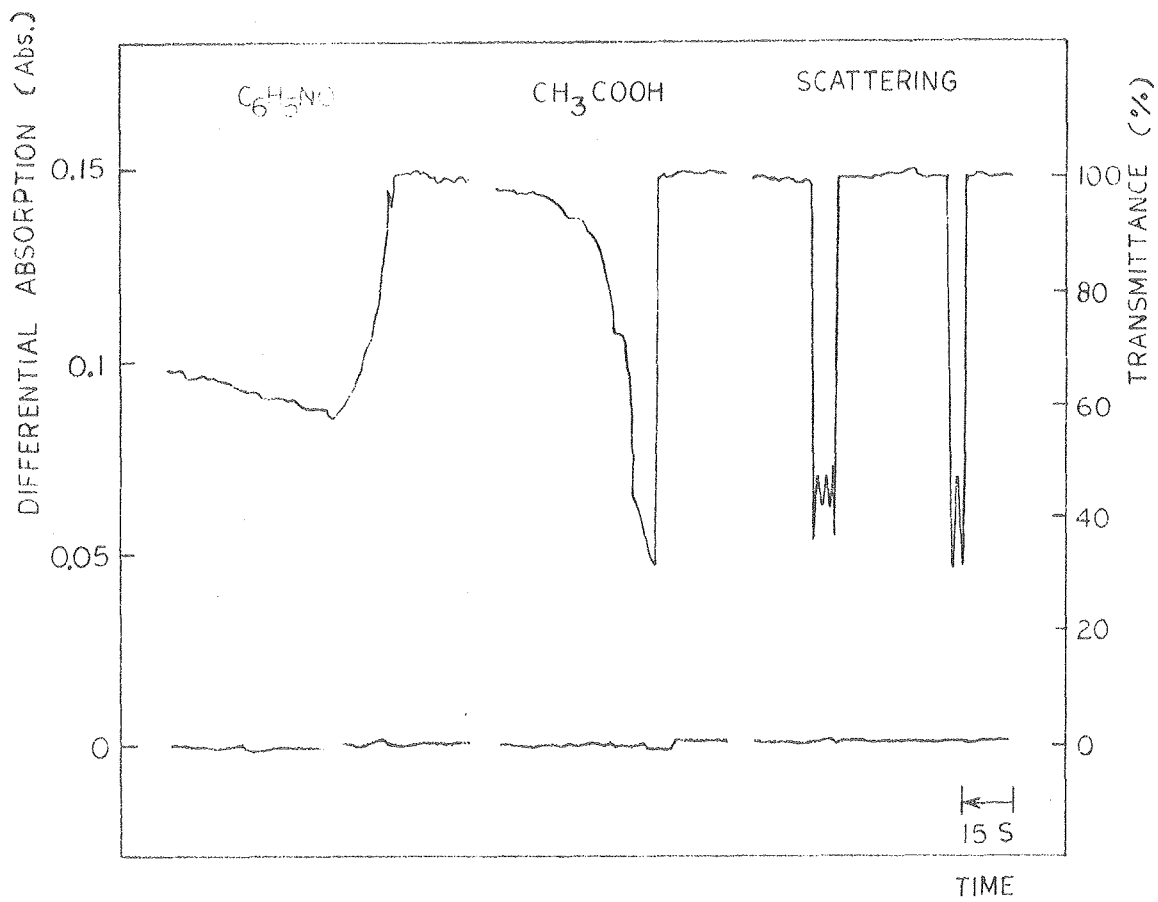

XBL 789-10677

Fig. 10

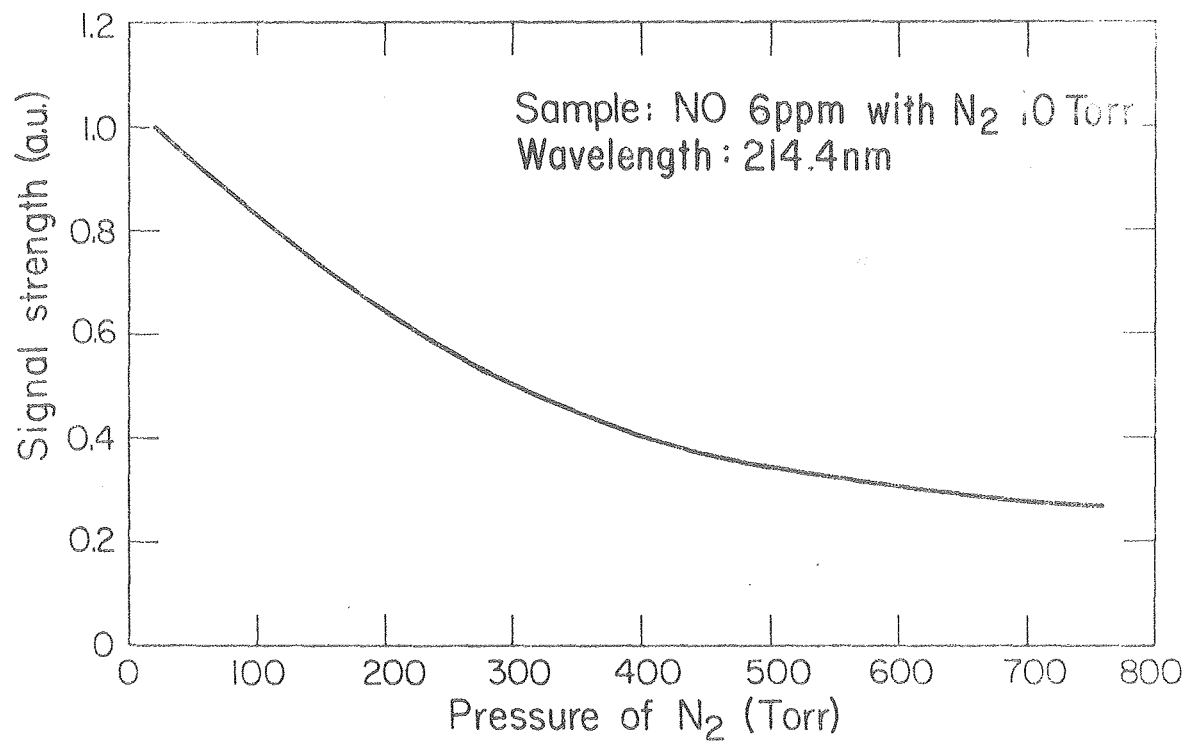

XBL 795-1608A

Fig. 11

