

Lawrence Berkeley National Laboratory

Recent Work

Title

VISUALIZATION OF FLY-ASH PARTICLES IN MACROPHAGES USING COLAR X-RAY MAPPING

Permalink

<https://escholarship.org/uc/item/7463n4w8>

Author

Pawley, James

Publication Date

1977-09-01

C.2

VISUALIZATION OF FLY-ASH PARTICLES IN
MACROPHAGES USING COLOR X-RAY MAPPING

James Pawley and Gerald Fisher

DONNER LABORATORY

September 1977

RECEIVED
LAWRENCE
BERKELEY LABORATORY

JUN 1 1978

LIBRARY AND
DOCUMENTS SECTION

Prepared for the U. S. Department of Energy
under Contract W-7405-ENG-48

TWO-WEEK LOAN COPY

*This is a Library Circulating Copy
which may be borrowed for two weeks.
For a personal retention copy, call
Tech. Info. Division, Ext. 6782*

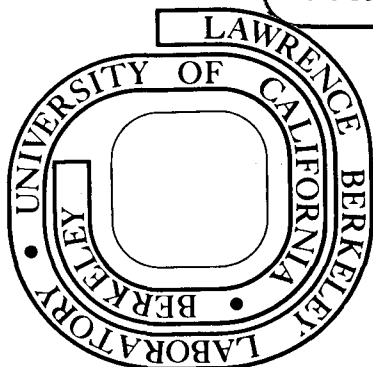

C.2

DISCLAIMER

This document was prepared as an account of work sponsored by the United States Government. While this document is believed to contain correct information, neither the United States Government nor any agency thereof, nor the Regents of the University of California, nor any of their employees, makes any warranty, express or implied, or assumes any legal responsibility for the accuracy, completeness, or usefulness of any information, apparatus, product, or process disclosed, or represents that its use would not infringe privately owned rights. Reference herein to any specific commercial product, process, or service by its trade name, trademark, manufacturer, or otherwise, does not necessarily constitute or imply its endorsement, recommendation, or favoring by the United States Government or any agency thereof, or the Regents of the University of California. The views and opinions of authors expressed herein do not necessarily state or reflect those of the United States Government or any agency thereof or the Regents of the University of California.

Pulmonary Macrophage and Epithelial Cells

**Proceedings of the
Sixteenth Annual Hanford Biology Symposium
at Richland, Washington, September 27-29, 1976**

**Sponsored by
Division of Biomedical and Environmental Research
Energy Research and Development Administration
and
Pacific Northwest Laboratories
Battelle Memorial Institute**

**Editors
C. L. Sanders
R. P. Schneider
G. E. Dagle
H. A. Ragan
Pacific Northwest Laboratories**

1977

**Published by
Technical Information Center
Energy Research and Development Administration**

Library of Congress Cataloging in Publication Data

Hanford Biology Symposium, 16th, Richland, Wash., 1976.
Pulmonary macrophage and epithelial cells.

(ERDA symposium series ; 43)
"CONF-760927."

Includes bibliographical references and index.

1. Macrophages—Congresses. 2. Epithelium—Congresses. 3. Lungs—Congresses. I. Sanders, Charles Leonard, 1938- II. United States. Energy Research and Development Administration. Division of Biomedical and Environmental Research. III. Battelle Memorial Institute, Columbus, Ohio. Pacific Northwest Laboratories, Richland, Wash. IV. Title. V. Series: United States. Energy Research and Development Administration. ERDA symposium series ; 43.
[DNLM: 1. Macrophages—Congresses. 2. Lung—Congresses. 3. Epithelial cells—Congresses. W3 HA21 1976p / WF600 H238 1976p]
QR185.8.M3H36 1976 599'.02 77-12024
ISBN 0-87079-204-0

Available as CONF-760927 for \$12.50 from

National Technical Information Service
U. S. Department of Commerce
Springfield, Virginia 22161

ERDA Distribution Category UC-48

September 1977

Visualization of Fly-Ash Particles in Macrophages Using Color X-Ray Mapping

JAMES PAWLEY* and GERALD FISHER†

*Donner Laboratory, Lawrence Berkeley Laboratory, Berkeley, California; †Radiobiology Laboratory, University of California, Davis, California

ABSTRACT

A new method is described for applying color X-ray mapping to the microanalysis of coal fly ash both before and after ingestion of the fly ash by mouse pulmonary alveolar macrophages. The system uses a scanning electron microscope with energy dispersive X-ray spectrometer and a color television monitor to produce simultaneous X-ray maps of three elements. Because higher average real-time count rates are possible when the sample is scanned at television rate, three element maps of fields containing 100 to 200 particles can be produced in 1 to 5 min, and thus the system is valuable as a screening tool. Particles having cross sections as small as 0.5% of the scanned area can be detected, provided that the element being mapped constitutes at least 10 to 20% of the mass of the particles. Particles inside critical point dried pulmonary alveolar macrophages, previously exposed to respirable polydisperse stack fly ash in vitro, have been mapped successfully.

As the energy industry increases its reliance on coal, there has been a renewed interest in the ultimate fate and possible biological effects of the by-products of coal production and combustion.¹⁻⁴

In 1974, 6×10^8 tons of coal were mined in the United States and, after combustion, 11% of this was ash. In modern utility boilers fired with pulverized coal, 80% of the ash is converted to fly ash. Most of this is removed from the flue gas by electrostatic precipitators or other collection devices, but approximately 10^6 tons is probably released to the atmosphere. The material most likely to escape the precipitators is small [mass median diameter (MMD) $< 5 \mu\text{m}$] and this prolongs its residence time in the atmosphere and also

increases the probability that, once inhaled, the material will be deposited in the lung.⁵ Furthermore, some of the trace elements that are known to be biologically harmful seem to be preferentially concentrated in or on smaller particles.⁶

The massive quantity of this material produced must not blind us to the fact that most biological effects will be produced at the cellular level by a small number of particles weighing a few picograms. Because these particles are too small for careful study in the light microscope, the study of fine particulates on a particle-by-particle basis requires such microtechniques as scanning and transmission electron microscopy and electron microprobe analysis. Obtaining information on elemental composition using the microprobe is complicated by the difficulty of obtaining data on a statistically significant number of particles either in their free state or after their interaction with biological targets, such as the pulmonary macrophage.

This paper describes an optimized method of color X-ray mapping which we hope can help alleviate this problem by permitting a large number of particles to be screened for the presence of up to three elements simultaneously. This method differs from previous methods of color X-ray mapping^{7,8} because it is 10 to 30 times more rapid and requires minimal operator involvement.

METHODS

Since a preliminary version of this system has been described⁹ and a more complete description containing examples of colored X-ray maps will soon be available,¹⁰ only a brief outline of the operation of the system is included here.

The sample is scanned at television rate in a scanning electron microscope (SEM) using a current sufficient to produce the maximum possible average real-time count rate from an attached dispersive X-ray spectrometer detector (about 3000 cps for a detector with a linear amplifier time constant, $t_c = 8$ to $10 \mu\text{sec}$). The output of the linear amplifier is applied to three single-channel analyzers [Fig. 1(a)] so arranged that a high logic signal is passed to one of three latches whenever the linear amplifier signal is in that window. A strobe pulse is produced by the linear amplifier at the instant that the linear output reaches a peak, which is exactly $44 \mu\text{sec}$ after the X ray is detected (t_0). This strobe pulse triggers the latches so that their outputs continue to mirror the state of their inputs at the instant that the strobe pulse arrives. The latch outputs are each fed to one input of an AND gate. The strobe pulse is also

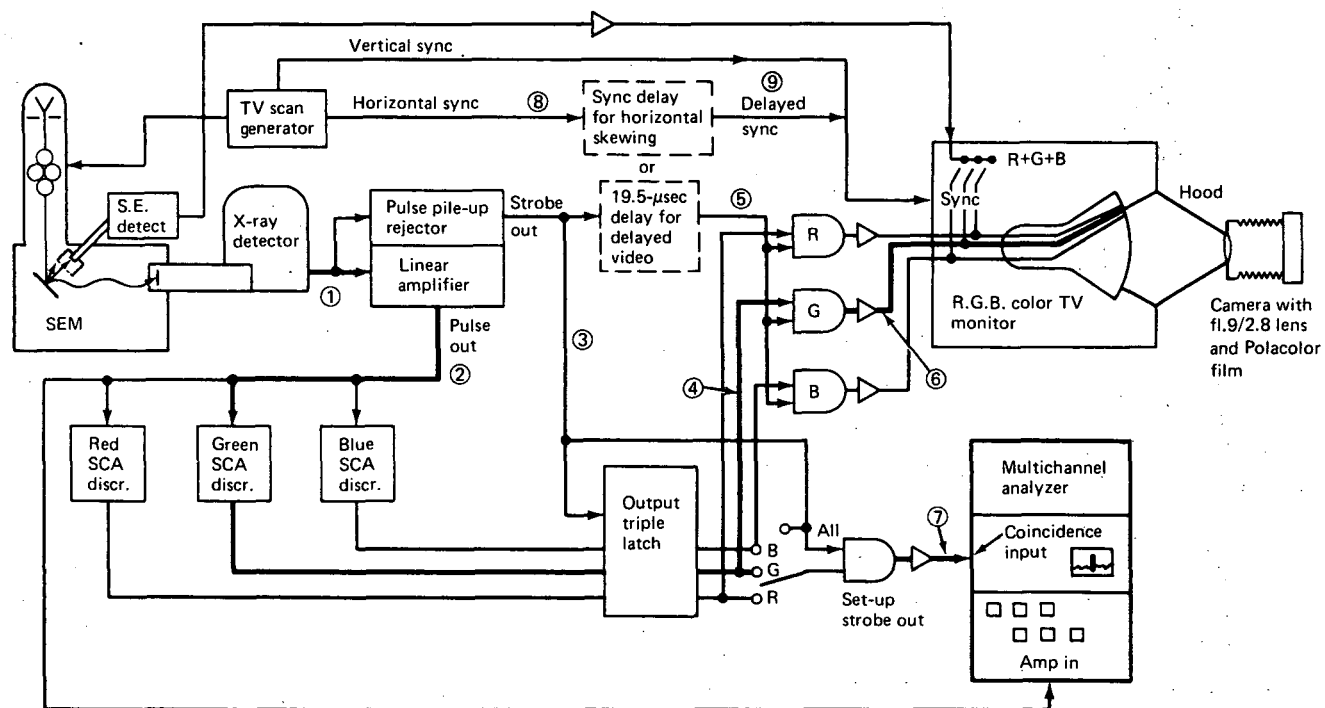

(a)

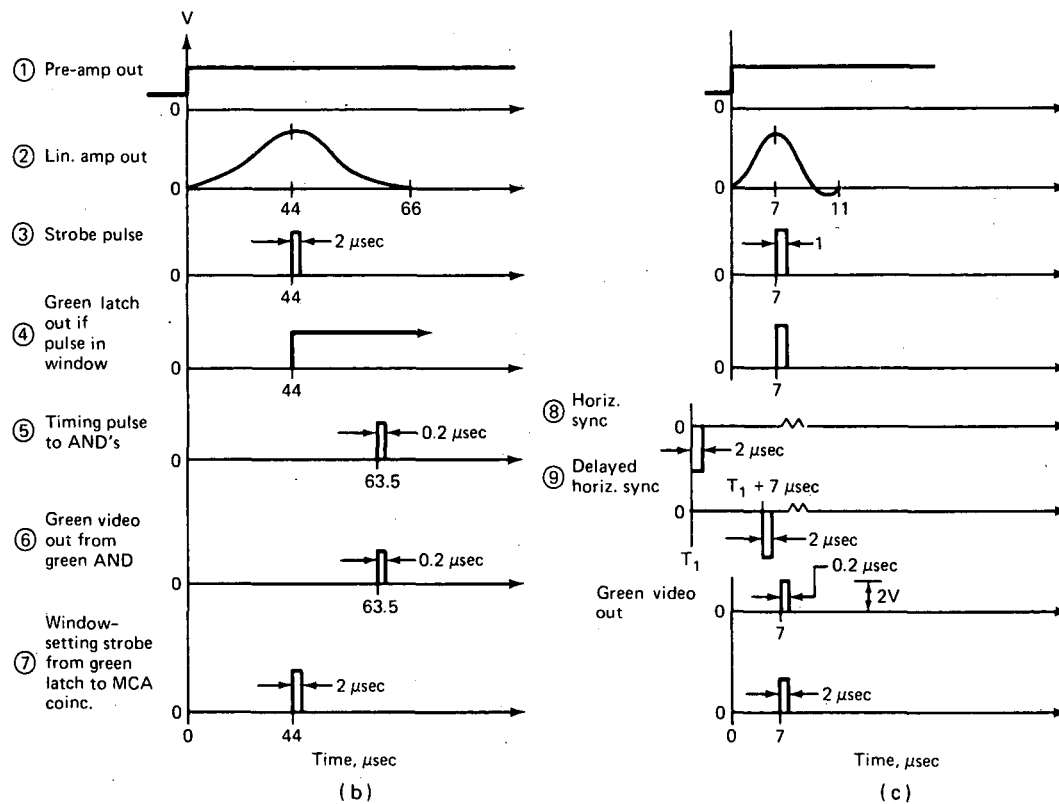

Fig. 1 Block diagram of simultaneous three-element color X-ray mapping system. Signals present in the system, when used in delayed video mode or horizontal scan skewing mode, are diagrammed in parts (b) and (c), respectively.

used to produce a delayed video pulse 0.2 μsec wide and delayed by exactly 19.5 μsec , which is applied to the second input of all three AND gates. These gates will therefore produce a 0.2- μsec pulse a total of $44 + 19.5 = 63.5$ μsec after t_0 only if the linear-amplifier output pulse peak was in the appropriate window. After this pulse is buffered, it is passed to one input of a red-blue-green color television monitor, where it is displayed as a dot of a particular primary color. This dot is then recorded on instant process color film. The delay circuitry is necessary because the time between t_0 and the time that the linear amplifier output can be analyzed (44 μsec) is long compared to television horizontal sweep rate (63.5 $\mu\text{sec}/\text{line}$). The delay procedure has the effect of displaying an X-ray count exactly one line below the point from which it is detected and is called delayed video. The pulses referred to are shown in Fig. 1(b); the circled numbers indicate the parts of the schematic diagram where each pulse will be found.

Delayed video produces a display dead time of 63.5 μsec , which is comparable to the dead time of an amplifier having a $t_c = 8$ μsec . If a linear amplifier having $t_c < 8$ μsec is used to increase the maximum real-time count rate at some loss in energy resolution, a different system may be used to compensate for the delay between t_0 and the linear amplifier peak. This second method is called horizontal scan skewing, and the relevant pulses are shown in Fig. 1(c). The video pulses are not delayed but are passed on immediately after the strobe pulse arrives. Registration is preserved by delaying the horizontal sync pulses sent to the monitor so that the display beam lags the probing beam by the correct amount.

A signal composed of the output of a switch-selected latch ANDed with the strobe pulse is passed to an attached multichannel analyzer (MCA) used in the coincidence mode. This allows a spectrum composed of only the counts in a particular window to be generated on the MCA, and thus the window is easy to set.

The samples used to prepare the maps shown during the symposium, which are not included here because publishing considerations do not permit the reproduction of figures in color, consist of NBS No. SRM-1633* coal fly ash, size-classified stack fly ash, or mouse pulmonary alveolar macrophages exposed to the stack fly ash. The NBS fly ash was deposited onto smooth carbon SEM stubs and coated with carbon by vacuum evaporation. A fine fraction

*National Bureau of Standards, Standard Reference Material, No. 1633, *Trace Elements in Coal Fly Ash*.

(MMD = 2.2 μm) stack fly ash¹ was deposited on Formvar-coated copper EM grids to reduce the bremsstrahlung production in the substrate. The mouse pulmonary alveolar macrophages were obtained by lung lavage and exposed to stack fly ash of 2.2- μm MMD by a modification of the method detailed elsewhere in this volume.^{1,2} After exposure, drops of cell suspension were placed on Formvar-coated EM grids that had first been dipped in 0.1% poly-lysine solution^{1,3} and then blotted dry. The poly-lysine made the cells adhere to the Formvar while the grids were first fixed in cacodylate-buffered glutaraldehyde-formaldehyde and then dehydrated in ethanol before being critical point dried using amyl acetate and liquid CO_2 . After the grids were dried, they were coated with evaporated carbon.

With a 25-kV beam voltage, we recorded maps and corresponding secondary electron images from the television monitor. Exposure times were 3 to 10 min, and 5×10^4 to 3×10^5 counts were recorded at magnifications of 2000 to 5000x (on the print). Elements mapped during the initial studies reported here included aluminum, sulfur, potassium, calcium, titanium, and iron, although future studies will map elements known to have deleterious biological effects, such as cadmium, selenium, arsenic, and lead.

RESULTS AND DISCUSSION

The results showed the method to be effective in producing images in 1 to 5 min which were sufficient to detect particles having high concentrations of a mapped element in fields containing up to 200 particles. The samples of NBS and fine stack fly ash proved to be very heterogeneous, and several maps showed that virtually all of a particular element in a field of over 100 particles was concentrated in a single particle. Conclusions based on such maps regarding the elemental composition of individual particles were verified by spot-mode analysis of the particles involved. Fine particles containing high concentrations of iron, calcium, or titanium which had been phagocytized by pulmonary alveolar macrophages could be clearly visualized, particularly if they were near the cell surface. One map included a part of a copper EM grid in the field of view, and, although this gave rise to a perceptible increase in the background level, this increased background level is in no way comparable to the intensities produced by the intracellular particles.

Our studies are just beginning, but we hope to use this tool to discover whether trace elements of biological interest, such as cadmium, selenium, arsenic, zinc, and lead, are distributed nonuni-

formly, as are the elements mapped in this study. This knowledge will permit a better estimation of the biological toxicity of such particles. It may also provide a test for one theoretical explanation for the predominance of such elements in smaller particles because, if small particles show the increased concentration simply because they provide a greater specific surface area on which volatile elements can condense as the flue gases cool,^{6,14} then we would not expect large variations in concentration between particles of the same size. Finally, by correlating information on the elemental composition of particles within pulmonary alveolar macrophages with the morphological appearance of the cells after various periods of incubation, we hope to determine differential uptake rates and toxicity on a cell-by-cell basis.

ACKNOWLEDGMENTS

We are grateful to Dr. T. L. Hayes, Donner Laboratory, Lawrence Berkeley Laboratory, and to Dr. W. S. Tyler, California Primate Research Center, University of California, Davis, for their encouragement and support. We also thank Dr. C. Mosher, Nuclear Equipment Corp., San Carlos, Calif., for his aid in the technical design of the prototype. This project was supported, through the Donner Laboratory, by the Energy Research and Development Administration, Environmental Protection Agency Award D5-E681, and the National Heart and Lung Institute of the National Institutes of Health (Fellowship 1 F32 HL 02884-01); and, through the Radiobiology Laboratory, by the Energy Research and Development Administration.

REFERENCES

1. R. L. Davison, D. F. S. Natusch, J. R. Wallace, and C. A. Evans, Jr., Trace Elements in Fly Ash, *Environ. Sci. Tech.*, 8(13): 1107-1113 (1974).
2. W. L. Faith and A. A. Atkinson, Jr., *Air Pollution*, 2nd ed., Wiley-Interscience, New York, 1972.
3. G. L. Fisher, D. P. Y. Chang, and M. Brummer, Fly Ash Collected from Electrostatic Precipitators: Microcrystalline Structures and the Mystery of the Spheres, *Science*, 192: 555-557 (1976).
4. J. M. Ondov, R. C. Ragaini, R. E. Heft, G. L. Fisher, D. Silberman, and B. A. Prentice, *Interlaboratory Comparison of Neutron Activation and Atomic Absorption Analyses of Size-Classified Stack Fly Ash*, Proceedings of the Eighth Methods and Standards for Environmental Measurement Materials Research Symposium, National Bureau of Standards, Gaithersburg, Maryland, 1976 (in press).

5. D. F. S. Natusch and J. R. Wallace, Urban Aerosol Toxicity: The Influence of Particle Size, *Science*, 186: 695-699 (1974).
6. D. F. S. Natusch, J. R. Wallace, and C. A. Evans, Toxic Trace Elements: Preferential Concentration in Respirable Particles, *Science*, 183: 202-204 (1974).
7. H. Yakowitz and K. F. T. Heinrich, Color Representation of Electron Microprobe: Area-Scan Images by a Color Separation Process, *J. Res. Natl. Bur. Stand., A*, 73: 113 (1969).
8. M. P. Jones, J. Gavrilovic, and C. H. M. Beaven, Colour Synthesis as an Aid to Electron Probe X-Ray Microanalysis, *Trans. Inst. Min. Met., B*, 75: B274 (1966).
9. J. B. Pawley, T. L. Hayes, and T. H. Falk, Simultaneous Three Element X-Ray Mapping Using Color TV, in *Proceedings of the 9th SEM Symposium*, Toronto, Canada, Om Johari (Ed.), pp. 187-195, Univ. Chicago Press, Chicago, 1976.
10. J. B. Pawley and G. L. Fisher, Rapid Elemental Characterization of Coal Combustion By-Products Using Simultaneous Three-Color X-Ray Mapping and Digital Scan-Stop, *J. Microsc.* (in press).
11. A. R. McFarland, G. L. Fisher, B. A. Prentice, and R. W. Bertch, A Fractionator for Size-Classification of Aerosolized Solid Particulate Matter, *Environ. Sci. Tech.* (in press).
12. F. F. Hahn, G. L. Newton, and L. Bryant, In Vitro Phagocytosis of Monodisperse Particles by Alveolar Macrophages (this volume).
13. D. Mazia, G. Schatten, and W. Sale, Adhesion of Cells to Surfaces Coated with Poly-Lysine: Applications to Electron Microscopy, *J. Cell Biol.*, 66: 198-200 (1975).
14. R. W. Linton, A. Loh, and D. F. S. Natusch, Surface Predominance of Trace Elements in Airborne Particles, *Science*, 191: 852-854 (1976).

This report was done with support from the Department of Energy. Any conclusions or opinions expressed in this report represent solely those of the author(s) and not necessarily those of The Regents of the University of California, the Lawrence Berkeley Laboratory or the Department of Energy.

TECHNICAL INFORMATION DEPARTMENT
LAWRENCE BERKELEY LABORATORY
UNIVERSITY OF CALIFORNIA
BERKELEY, CALIFORNIA 94720