

# Lawrence Berkeley National Laboratory

## Recent Work

### Title

REPORT ON THE 1984 LBL WORKSHOP ON DETECTORS FOR RELATIVISTIC NUCLEAR COLLISIONS

### Permalink

<https://escholarship.org/uc/item/7bn1587m>

### Author

Schroeder, L.S.

### Publication Date

1984-11-01

c2



# Lawrence Berkeley Laboratory

UNIVERSITY OF CALIFORNIA

RECEIVED

LAWRENCE  
BERKELEY LABORATORY

JAN 7 1985

LIBRARY AND  
DOCUMENTS SECTION

Invited talk at the Conference on Instrumentation  
for Heavy Ion Research, Oak Ridge, TN,  
October 22-24, 1984

REPORT ON THE 1984 LBL WORKSHOP ON DETECTORS  
FOR RELATIVISTIC NUCLEAR COLLISIONS

L.S. Schroeder

November 1984

**TWO-WEEK LOAN COPY**  
*This is a Library Circulating Copy  
which may be borrowed for two weeks.*

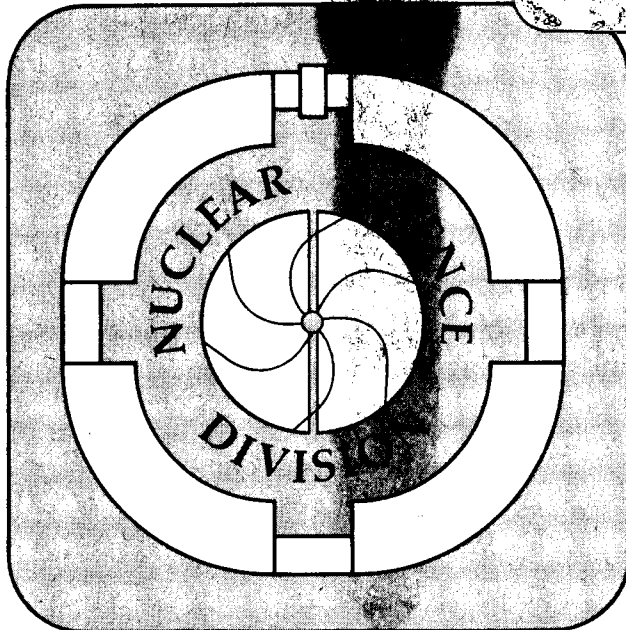

LBL-18626  
c2

## **DISCLAIMER**

This document was prepared as an account of work sponsored by the United States Government. While this document is believed to contain correct information, neither the United States Government nor any agency thereof, nor the Regents of the University of California, nor any of their employees, makes any warranty, express or implied, or assumes any legal responsibility for the accuracy, completeness, or usefulness of any information, apparatus, product, or process disclosed, or represents that its use would not infringe privately owned rights. Reference herein to any specific commercial product, process, or service by its trade name, trademark, manufacturer, or otherwise, does not necessarily constitute or imply its endorsement, recommendation, or favoring by the United States Government or any agency thereof, or the Regents of the University of California. The views and opinions of authors expressed herein do not necessarily state or reflect those of the United States Government or any agency thereof or the Regents of the University of California.

LBL-18626

REPORT ON THE 1984 LBL WORKSHOP ON DETECTORS FOR  
RELATIVISTIC NUCLEAR COLLISIONS

L.S. Schroeder

Nuclear Science Division  
Lawrence Berkeley Laboratory  
University of California  
Berkeley, California 94720

November 1984

This work was supported by the Director, Office of Energy  
Research, Division of Nuclear Physics of the Office of High Energy  
and Nuclear Physics of the U.S. Department of Energy under Contract  
No. DE-AC03-76SF00098.

REPORT ON THE 1984 LBL WORKSHOP ON DETECTORS FOR  
RELATIVISTIC NUCLEAR COLLISIONS\*

L.S. SCHROEDER  
Nuclear Science Division  
Lawrence Berkeley Laboratory  
University of California  
Berkeley, California 94720

In this talk I will be reviewing the highlights of the recent Workshop on Detectors for Relativistic Nuclear Collisions, held March 26-30, 1984, at the Lawrence Berkeley Laboratory. For a more complete report I refer you to the Proceedings of the Workshop.<sup>1</sup> The Workshop was also summarized at the Quark Matter '84 meeting in Helsinki this last June.<sup>2</sup> For additional information on detector requirements for high energy nuclear collisions, consult the talks of T. Ludlam, H. Specht, and A. Sandoval given at this Conference.

In the time available, I want to not only give you a feeling for the detector concepts discussed and in many cases developed at the Workshop, but also I hope to leave you with an overall impression of the tremendous strides that have been made in coming to grips with the very complex collisions that we will encounter at higher energies.

---

\*This work was supported by the Director, Office of Energy Research, Division of Nuclear Physics of the Office of High Energy and Nuclear Physics of the U.S. Department of Energy under Contract No. DE-AC03-76SF00098.

L.S. SCHROEDER

1. INTRODUCTION

There were several reasons for having a dedicated Detector Workshop at this time, including: (i) at Brookhaven a transfer line between the Tandem Van de Graaff and the AGS will provide light ions ( $A \leq 32$ ) at energies up to 15 GeV/nucleon beginning in late 1986; (ii) at the same time, an upgrade of the CERN PS injector by a GSI/LBL collaboration will provide  $^{16}\text{O}$  ions in the SPS at energies from 15-225 GeV/nucleon beginning in late 1986; (iii) in late 1983, the Nuclear Science Advisory Committee of the Department of Energy and the National Science Foundation recommended<sup>3</sup> that the next major nuclear physics facility in the U.S. should be a relativistic nuclear collider to explore the domain of high energy and baryon densities and hopefully shed light on deconfined hadronic matter--the quark-gluon plasma (QGP); and finally (iv) several national laboratories (BNL, LBL, ORNL) in the U.S. have active programs to look at collider options.<sup>4-6</sup>

Since the new fixed target capabilities will be coming on-line within two years, we felt it was both timely and necessary to start looking at the detector requirements imposed by these much higher energies. For the more distant colliders, an early start on detectors is also called for. Earlier meetings had considered detector requirements,<sup>7-9</sup> but we wanted to go beyond these and in particular hoped to identify any detector elements thought to be on the critical path for investigating the QGP that require an R&D effort.

To provide a focus for the Workshop it was decided to concentrate on the detection of the QGP. However, be aware that the conclusions arrived at for detectors are really in the context of high energy and baryon density achievable in central high energy nucleus-nucleus collisions and apply to

REVIEW OF 1984 LBL DETECTOR WORKSHOP

a potentially broader and richer range of phenomena than just the QGP. The individual working groups were roughly set up along lines of observables of the QGP.<sup>10,11</sup> Figure 1 is a representation of the evolution of a central nucleus-nucleus collision in the temperature ( $T$ ) and relative baryon density ( $\rho/\rho_0$ ) plane. Two trajectories, one emphasizing the baryon-rich plasma, the other the meson-rich (so-called "transparency") regime, are shown. In order for a detection scheme to be sensitive to the presence of the quark-gluon phase, measurements of direct radiation from the plasma itself (region 1) or from the rehadronized phase (region 2)

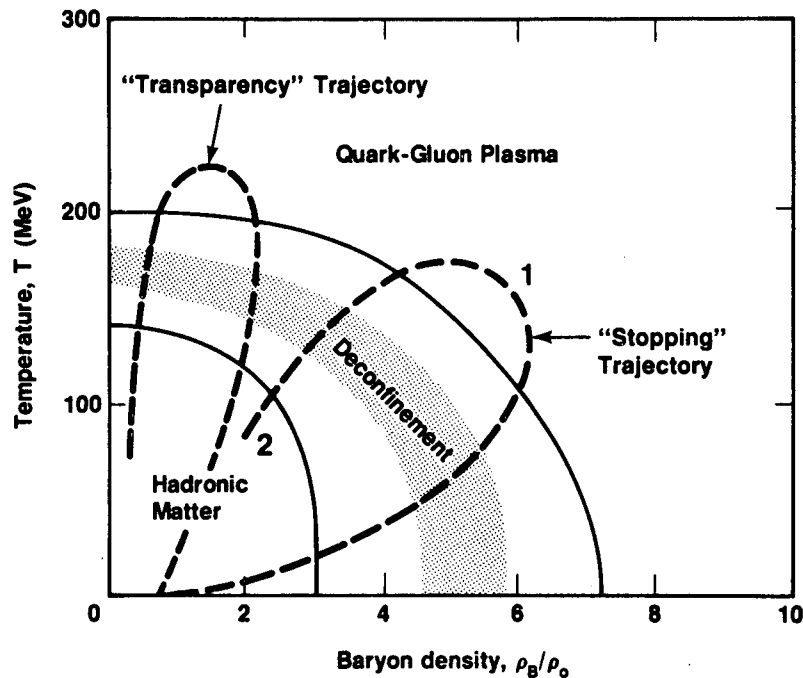

Experimental Signatures

- Region 1: Direct radiation from plasma (photons, leptons, lepton pairs)
- Region 2: Recondensed hadronic matter ( $\pi$ ,  $K$ ,  $p$ ,  $\bar{p}$ ,...)  
Possible free quarks, diquarks

FIGURE 1 Phase diagram with nuclear collision trajectories.

L.S. SCHROEDER

will be required. Figure 2 graphically illustrates some of the diagnostic tools that have been suggested for uncovering the QGP. Since the plasma is not thought to be stable, radiation from both regions could be present in each event. A device measuring hadrons in the final state would detect hadrons arising from ordinary hadronization processes found, for example, in nucleon-nucleon collisions and hadrons produced by quark and gluon recombination processes in the plasma phase. Theoretical guidance will certainly be required to differentiate between these sources.

At the Workshop we identified three areas of detector measurements which were used as the focus for individual groups. These were: (i) hadrons--generally concerning detection of strange particles and antibaryons, i.e., few particle measurements, often with reduced solid angle, (ii) event parameters--experiments with nearly  $4\pi$  acceptance, measuring many of the particles in the final state, and (iii) penetrating probes--measurements of photons, leptons, lepton pairs, etc., which are thought to be suitable in probing the hot, compressed stage of the collision. In each category there was a working group for fixed target and collider geometries. Each group had conveners who organized and guided the efforts of the group.<sup>12</sup> The conveners are the ones who made the Workshop a success.

## 2. WHAT LIES AHEAD AT HIGHER ENERGIES?

As we increase the bombarding energy the most immediate consequence in a central nucleus-nucleus collision is that the multiplicity of final state particles will increase dramatically. At the Bevalac the GSI/LBL Plastic Ball experiment (see talk by H.-A. Gustafsson in this Proceed-



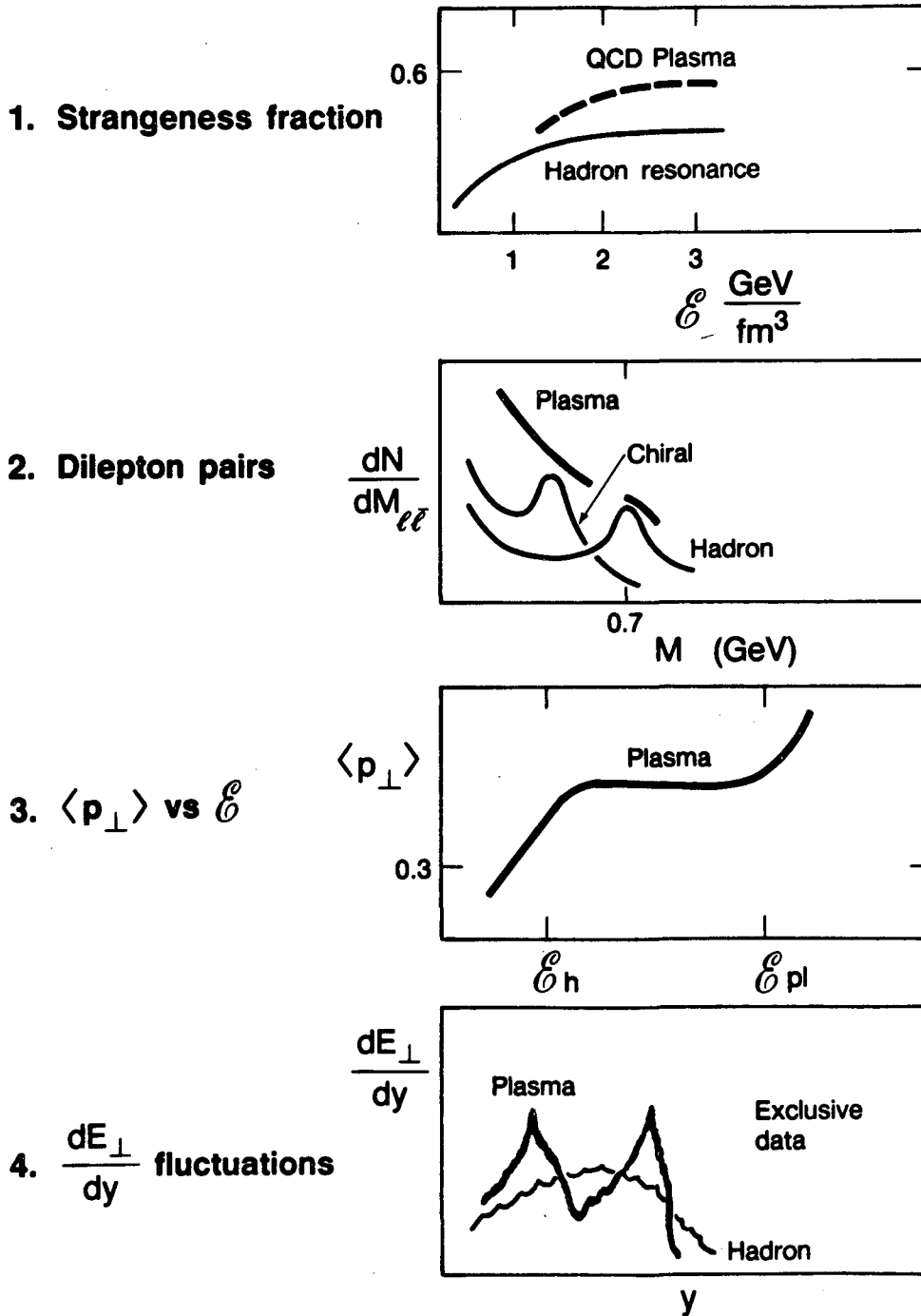

FIGURE 2 Some possible diagnostic tools for looking at the quark-gluon plasma.

L.S. SCHROEDER

ings) observes ~100-200 charged particles being produced in central Au + Au collision at 1.05 GeV/nucleon. In this region, the final states are dominated by nucleons and light fragments with pions making up ~10-20%. At 10 GeV/nucleon, corresponding to energies available at the AGS, we anticipate several hundred pions will be created, comparable to the number of nucleons. At much higher energies, such as the Si + Ag JACEE event<sup>13</sup> at ~4-5 TeV/nucleon (laboratory energy), we expect to see a thousand or more mesons ( $\pi, K$ ) being created. These estimates are in line with results from recent event simulations based on extrapolations of pp and pA data. Many detector-related questions naturally arise when considering the high multiplicity final states resulting from central collisions, including: (i) to what extent will tracking of individual particles still be possible? (ii) will calorimetry replace tracking in high multiplicity environment? (iii) what are the appropriate central collision triggers? (iv) how to record and process all the information?, and (v) are there existing detector designs (e.g., UA1/UA2) that can do the job?

### 3. DETECTORS IN FIXED TARGET AND COLLIDER GEOMETRIES

A brief comment about some of the differences to be expected for experiments done in fixed target versus collider modes. As one increases the incident energy, the center of mass for fixed target experiments moves rapidly forward. This means that the large multiplicity of particles produced in these collisions will be tightly focused in the forward direction, putting severe demands on the granularity of detector elements if one wishes to preserve individual particle identification (ID) capability. At the same time the

## REVIEW OF 1984 LBL DETECTOR WORKSHOP

momenta of the outgoing particles will span a large dynamic range, again testing one's ability to provide particle ID over as large a range as possible. However, the large momentum boost experienced by unstable particles (e.g.,  $\Lambda^0$ ,  $\bar{\Lambda}^0$ ) will make them more accessible to detection by increasing their apparent lifetime. In collider geometry, particle emission is over  $4\pi$ , somewhat easing the demands on detector granularity. The energy range of particles being produced will generally be in the few hundred MeV to few GeV range at mid-rapidity (generally thought to be the region of most interest for the QGP). Here particle identification techniques are generally well understood. The most forward ( $\theta_{\text{cm}} \approx 0-15^\circ$ ) and backward ( $\theta_{\text{cm}} \approx 165-180^\circ$ ) sections of collider detectors correspond to large values of rapidity and will look quite similar to detectors at forward angles for fixed target work.

Now I want to review results from the individual working groups. Again, I can only cover some of the highlights and refer you to the Workshop Proceedings<sup>1</sup> for a more complete picture.

### 4. HADRONS-FIXED TARGET

This group considered fixed target experiments measuring single-particle or few-particle observables. Generally such experiments would be done with reduced solid angle coverage. Experiments considered were: (i) measurement of strange particles and antibaryons for flavor tasting of the QGP, (ii) Hanbury-Brown/Twiss (HBT) like-particle interferometry to obtain information on the space-time evolution of the particle source, and (iii) production of heavy flavors such as  $\phi(1020) = \phi(s\bar{s})$ ,  $\psi(3100) = \psi(c\bar{c})$ , to be used as probes of

L.S. SCHROEDER

the quark content of the QGP. A description of two of the detectors considered follows below. Other detectors such as streamer chambers (see talk by A. Sandoval in this Proceedings), solid state track detectors, and emulsion chambers, although discussed in the Workshop Proceedings, will not be covered here.

Considerable attention was paid to the question of how to trigger on central collisions. One possibility is the so-called "spectator veto" where one vetos events that produce near beam-rapidity particles in the projectile fragmentation region. Specifically, the spectator nucleons associated with the projectile will be emitted into a narrow cone of  $\Delta\theta < 1^\circ$  about the beam axis at 15 GeV/nucleon, and  $\Delta\theta < 0.1^\circ$  at 225 GeV/nucleon.

Figure 3 shows a relatively large solid angle spectrometer being designed by Gruhn et al.<sup>14</sup> for detecting strange baryons and antibaryons. Particular attention is given to  $\Omega$  production since being an (sss) system it could be a very sensitive probe of the plasma phase of the collision. The main elements of the detector are a superconducting magnet (3-7 T) to sweep away low momentum particles from the forward cone, a multiplicity array for centrality tagging, and a downstream projectile calorimeter in which low energy deposition would be used to signal a central event. The heart of the apparatus is a micro-TPC ( $\mu$ TPC) that will be used to recognize and identify both the initial and final strange particle decays (e.g.,  $\Xi^- \rightarrow \Lambda^0 \pi^-$  followed by  $\Lambda^0 \rightarrow p \pi^-$ ). Three planes of drift chambers would be used in front of the  $\mu$ TPC to increase momentum resolution.

Small solid angle devices also received attention. They offer several advantages, including: (i) excellent particle identification; (ii) good momentum resolution,

REVIEW OF 1984 LBL DETECTOR WORKSHOP

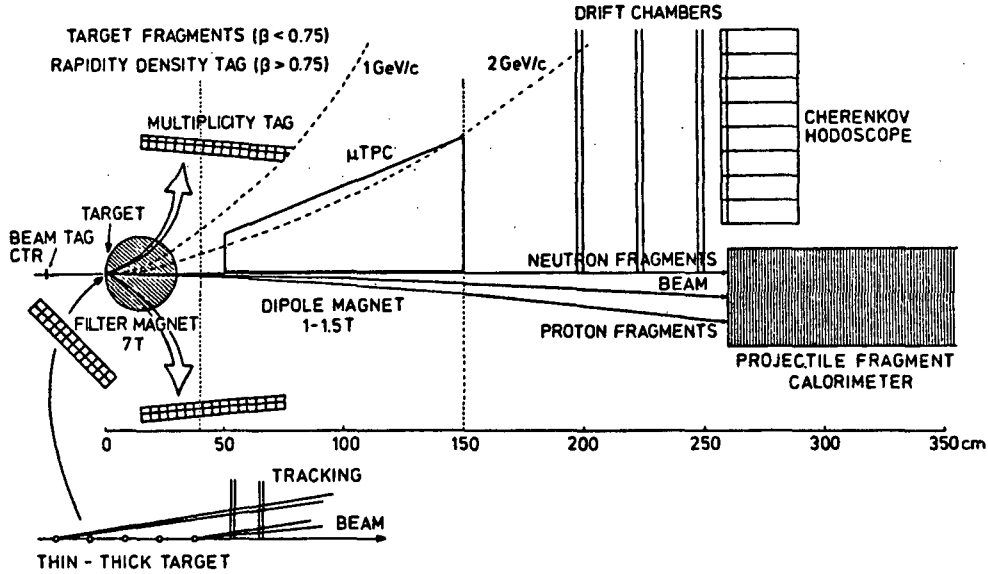
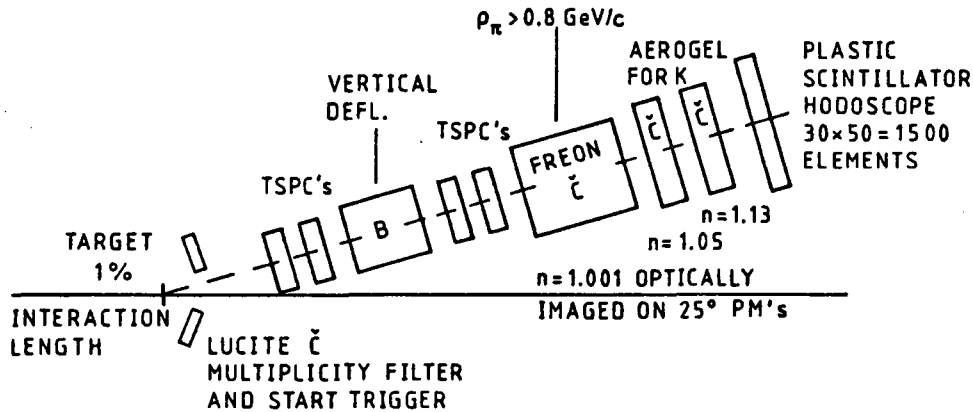

FIGURE 3 Proposed layout of an experiment to study strange baryon and antibaryon production with  $^{16}\text{O}$  beams at the CERN SPS.

$\Delta p/p \lesssim 1\%$ ; and (iii) are capable of taking high beam intensity. Figure 4 shows an example of a small solid angle ( $\Delta\Omega \approx 10$  msr) spectrometer being considered for studying charged particle spectra ( $\pi^\pm, K^\pm, p, \bar{p}, \Lambda^0$  decays) in the central rapidity region ( $5^\circ \lesssim \theta_{\text{Lab}} \lesssim 20^\circ$  for  $^{32}\text{S} + \text{Au}$  collisions at 15 GeV/nucleon). For  $10^7$  particles on target per sec up to 10 particles per event could be tracked and identified in the spectrometer. The main elements of the detector are the track segment projection chamber (TSPC), a large aperture vertical deflection magnet, and several arrays of threshold Cherenkov and aerogel counters. A lucite multisegmented Cherenkov multiplicity filter would be used to tag central events. The device would be employed to measure inclusive spectra of strange and nonstrange particles. Comparison of these spectra at several beam energies would provide information on the "nuclear temperature" of the participant zone,

L.S. SCHROEDER



Overall length 12 m,  $\theta: 5^\circ - 20^\circ$  Typically 10-15 particles to track

FIGURE 4 Single arm spectrometer being considered for possible use at the AGS (15 GeV/nucleon) with light ion beam ( $A \leq 32$ ).

and the strange particle yields have of course been suggested as a probe of the plasma phase.<sup>10,11,15</sup>

#### 5. EVENT PARAMETERS--FIXED TARGET

The group concentrated on detectors for fixed target work having nearly  $4\pi$  solid angle (i.e., complete azimuthal coverage). Four types were discussed, of which I shall present only the results for the so-called "idealized" detector. Two others, a nonmagnetic spectrometer and a streamer chamber, are very close to the systems being described by A. Sandoval elsewhere in this Proceedings.

The detectors were designed for both 15 GeV/nucleon  $^{32}\text{S}$  at the AGS and 225 GeV/nucleon  $^{16}\text{O}$  beams at the SPS. The range of physics they wished to cover included: (i) measurement of negative particle (mostly  $\pi^-$ ) and total multiplicity, (ii) pseudo-rapidity ( $dn/d\eta$ ) and rapidity ( $dn/dy$ ) distributions for charged particles, (iii) total  $\pi^\pm$  and  $\pi^0$

REVIEW OF 1984 LBL DETECTOR WORKSHOP

energy, (iv)  $E_T$  and  $p_T$ , (v) shape measurements (e.g., equilibration flow, jets), and (vi) particle correlations (e.g., HBT).

The idealized dipole detector conceived by this group is shown in Figure 5. It consists of a target surrounded by a cube of CCD detecting planes which act as vertex detector and multiplicity counter inside the uniform magnetic field region. Three-dimensional tracking chambers are spread throughout the volume of the magnet, with electromagnetic and hadronic calorimeters (located inside return yoke of dipole coils) and time-of-flight counters providing angular coverage (down to  $\theta_{\text{Lab}} \approx 20^\circ$ ). Downstream of the magnet would be additional tracking chambers, possible RICH (Ring Image Cherenkov) detectors for particle identification and more time-of-flight and calorimetry.

As suggested earlier, the number of particles will be large. For example, the results of a HIJET calculation<sup>16</sup> for  $^{16}\text{O} + \text{Au}$  at 15 GeV/nucleon for impact parameters  $b \leq$

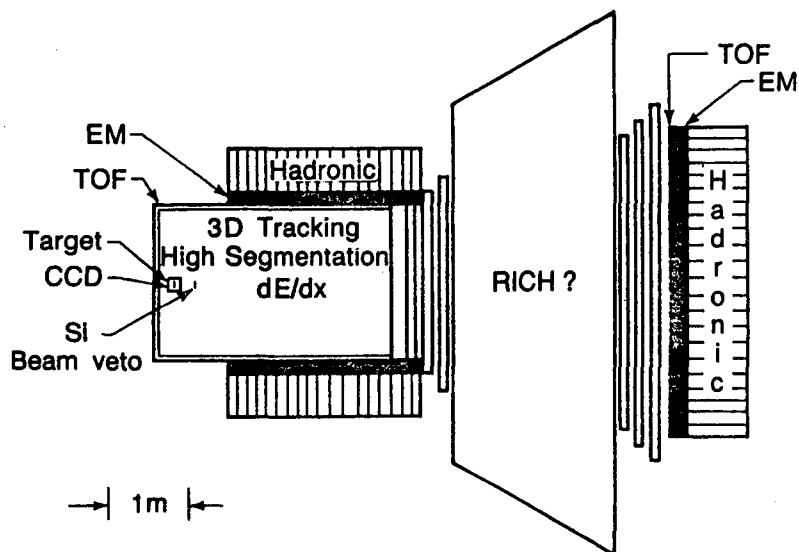

FIGURE 5 Idealized detector.

L.S. SCHROEDER

4 fm suggest several hundred particles. To see what this means for a detector like the idealized system of Figure 5, the group simulated what a typical central event at 15 GeV/nucleon would look like. Figure 6(a) shows such an event in the nonbend plane where pattern reconstruction is easier (tracks are straight lines). Figure 6(b) shows the same event in the bend plane (for a 0.5 T field). Clearly at 225 GeV/nucleon, due to the larger number of particles

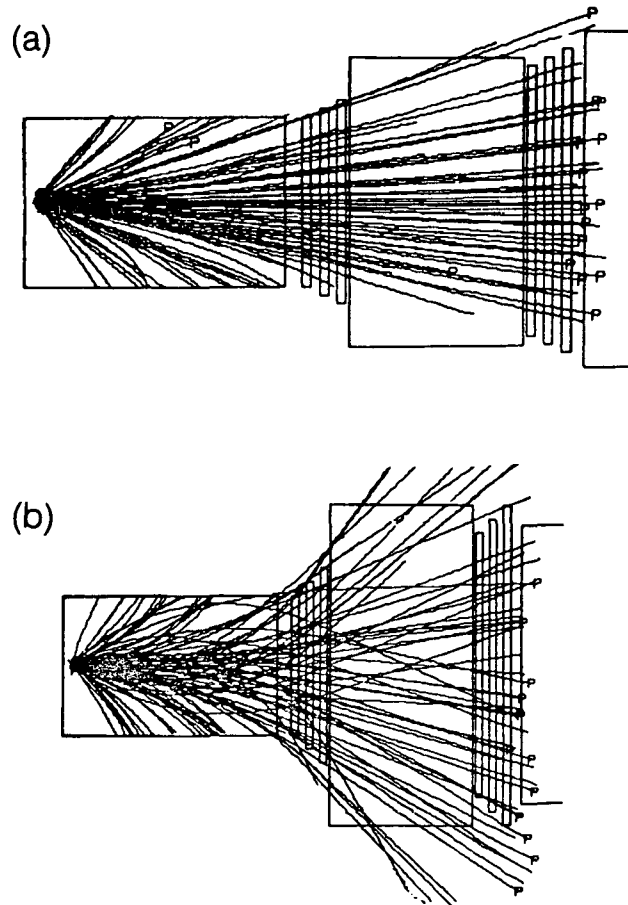

FIGURE 6 (a) 15 GeV/nucleon  $^{16}\text{O} + \text{Au}$  central collisions tracked in the nonbend plane of the idealized detector. (b) Same event in the bend plane with a field of 0.5 T.



## REVIEW OF 1984 LBL DETECTOR WORKSHOP

and their stronger forward focus, it will be even harder. The group suggests that a system like the European Hybrid Spectrometer which uses a series of dispersing dipoles spaced along the beam line would possibly be a better solution. They further concluded that heavy beam (Au + Au) fixed target experiments look very difficult at 15 GeV/nucleon and only calorimetry at 225 GeV/nucleon look feasible, even for  $^{16}\text{O}$ .

### 6. PENETRATING PROBES--FIXED TARGET

Efforts were directed at systems designed to detect directly produced electromagnetic probes (photons, leptons, lepton pairs) in light ion collisions over the energy range of 15-225 GeV/nucleon. Since these probes do not interact strongly with matter, they should carry information on the hot, compressed stage of the collision.

Although several different detectors were identified by the group, I will only mention plans to measure high mass muon pairs using a combination (NA34) of a spectrometer being designed for proton-nucleus experiments and the existing NA3 spectrometer to be used as the downstream muon spectrometer. Its elements are shown in Figure 7. Strong filtering ( $\approx 10$  interaction lengths) after the target is used to remove hadrons and limit decays of  $\pi$ 's and K's into muons. In this way they hope to get around problems arising from high multiplicities, lepton identification, and combinatorics. Multiple scattering in the filter will of course impose limits on the mass resolution and  $p_T$  of the dimuon pair. The front-end of the detector consists of a vertex detector and hadron calorimeter. In addition, they will also incorporate electron identification in the front-

L.S. SCHROEDER

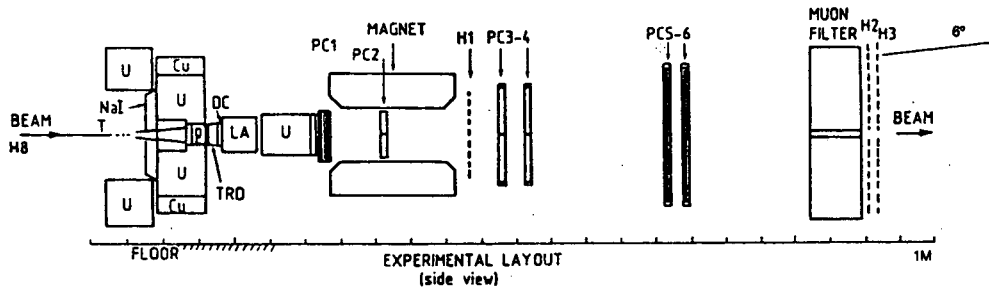

FIGURE 7 NA34 detector being proposed for light ion experiments at CERN.

end so that the low mass spectrum ( $m_{ee} < 1000$  MeV) can be studied. However, at the time of the Workshop, studies indicated that due to the large multiplicities expected (they quote  $\sim 300$  charged particles within a  $5^\circ$  cone for  $^{16}\text{O} + ^{195}\text{Pt}$  at 225 GeV/nucleon), individual electron tracking and identification may not be possible. Furthermore, the 150  $\pi^0$ 's expected/central event will yield between 1 and 2 e-pairs via Dalitz decay alone--complicating the process. A possible future development is the addition of a pair spectrometer (placed in an opening in the calorimeter section) to measure soft photons and electrons. Figure 8 shows, as an example, previous results on "low mass" dimuon pairs taken by the NA3 component of the system. These data represent dimuon pairs with  $p_T > 2$  GeV/c, a requirement that significantly increases the laboratory energy of the muons, thereby reducing the effects of multiple scattering. Please refer to the talk by H. Specht in this Proceedings for more complete information on the NA34 system.

## 7. PENETRATING PROBES--COLLIDER

This working group employed the same criteria for the physics and kinematic regimes of interest as described in Sec-

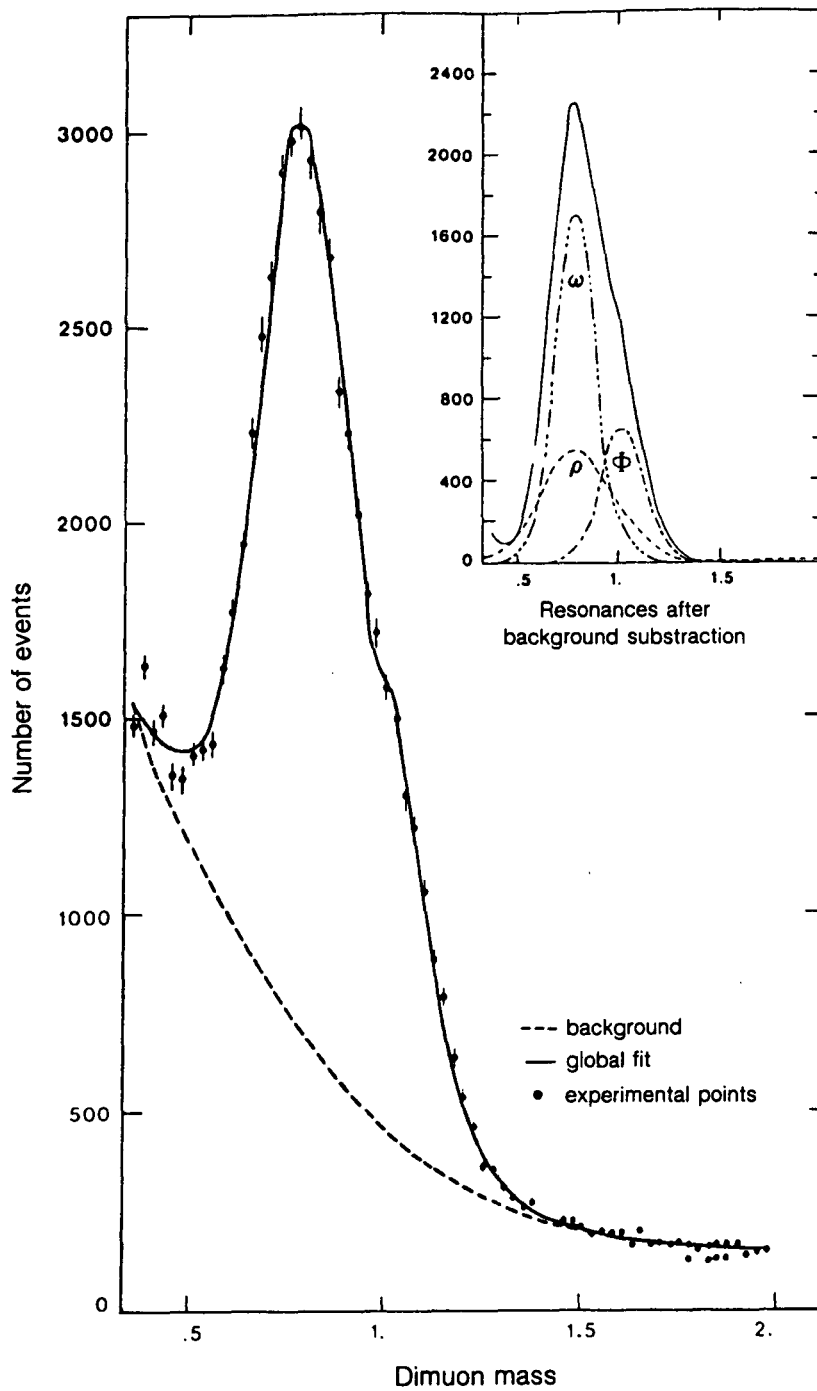

FIGURE 8  $\mu^+ \mu^-$  mass spectrum obtained by NA 3 experiment in 150 GeV/c  $\pi p$  interactions.

L.S. SCHROEDER

tion 6, the difference being that they were concerned with experiments done in the colliding beam mode, where the particles of interest spread out over  $4\pi$ . Figure 9 displays a picture of the geometry and kinematics in the collider frame of reference (positions of detector elements are shown). Note that the average momenta associated with different rapidity values are not large ( $<1-2$  GeV/c) for values of  $y$  near mid-rapidity. Also note that the extended source present in the collider will require some close-in tracking capability in order to differentiate between multiple event vertices.

The group did not undertake the design of a specific apparatus; however, they did conclude that a device as shown in Figure 10 (asymmetric version of a detector discussed at the Bielefeld<sup>7</sup> meeting) had many of the features required to

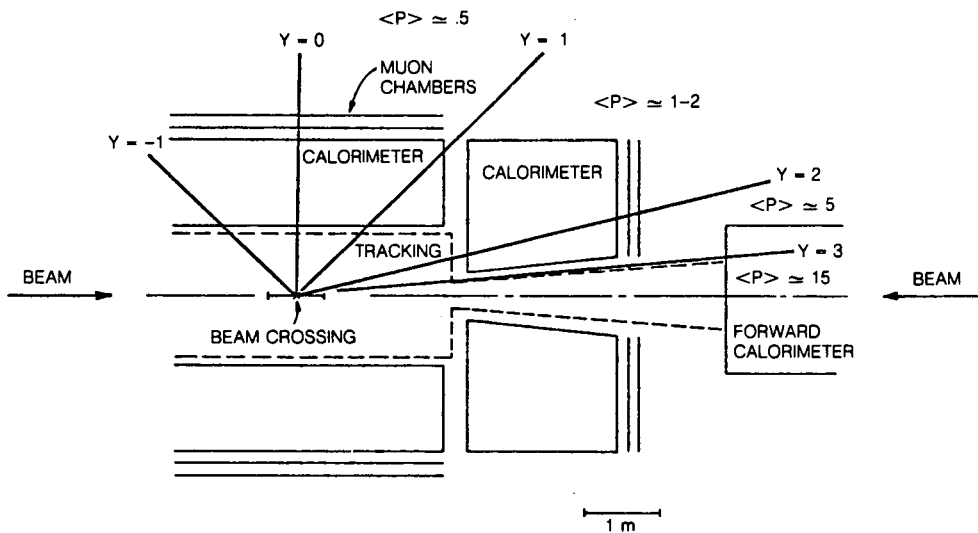

FIGURE 9 Schematic layout of the forward half of a collider detector showing the angular correspondence with pseudo-rapidity ( $y = -\ln(\tan \theta/2)$ ); this corresponds to the rapidity of particles whose  $m \ll p_T$ . The approximate average momentum,  $\langle p \rangle$ , is given for each rapidity interval.

## REVIEW OF 1984 LBL DETECTOR WORKSHOP

make it a useful dimuon detector. That is, it should be compact (to filter out hadrons) and be able to detect muons with  $p_{\mu} > 5 \text{ GeV}/c$  (momentum needed for effective hadron filtering). Also if one is interested in studying the small pair mass and transverse momentum characteristics of the plasma, one is restricted to  $|y| > 2$ , where the geometry and kinematics are similar to fixed target experiments, consistent with the design in Figure 10. The practical limit for pair mass muons in the central region in a collider would be  $M_{\mu\mu} > 3 \text{ GeV}$ --well above the mass region expected to be strongly populated by a thermalized quark-gluon plasma.

Using low mass electron pairs for probing the plasma will be difficult due to the high multiplicity expected. It was suggested that any electron detector should exploit the reduced numbers of particles expected at mid-rapidity. Dif-

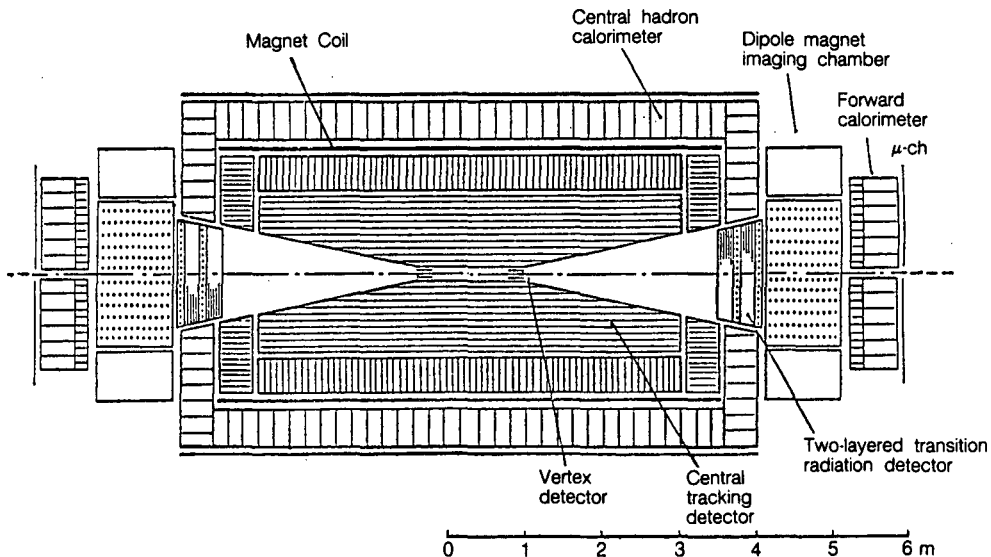

FIGURE 10 A  $4\pi$  detector for high energy colliding beam operations derived from a workshop study (Ref. 7) for a fixed target device at the CERN SPS. To make this detector, two of the SPS fixed target designs were placed back-to-back.

L.S. SCHROEDER

difficulties arise due to tracking in this environment, and an electron/hadron rejection of  $\geq 10^5$  is needed to be able to identify direct electrons. A specialized detector with relatively small aperture at  $\theta_{c.m.} = 90^\circ$  appears to be the best choice. The group noted that electron identification techniques are not easily incorporated in a large acceptance system, such as the one shown in Figure 10.

High  $p_T$  photons ( $p_T \geq 8$  GeV/c) are rare processes in hadron-hadron collisions and require high luminosities to be seen. However, they may be enhanced in central nucleus-nucleus collisions and should be looked for (luminosity will be a dominant issue). Shower counters, capable of resolving individual photons, will be required--all in a high multiplicity environment. The group concluded that much work remains in this area before experiments are undertaken.

One final physics point is worth noting. They discussed the possibility that jet-production<sup>17</sup> may be an interesting new signature for the plasma. Collider energies in excess of 50-75 GeV/nucleon will be required before such studies can even be started.

#### 8. HADRONS AND EVENT PARAMETERS--COLLIDER

This group considered detectors that address a broad range of needs for both hadron and event parameter experiments. For hadron studies they considered detection of baryons, mesons, and their antiparticles with the idea of obtaining information on: (i) strange/nonstrange and baryon/antibaryon production ratios; (ii) relative yields of particles with  $|s| = 0, 1, 2, 3$ ; (iii)  $\pi\pi$ ,  $KK$ ,  $pp$  intensity interferometry; and (iv) studies of multipion and multikaon systems.

## REVIEW OF 1984 LBL DETECTOR WORKSHOP

Event parameter measurements include: (i) multiplicity and energy and momentum flow as functions of rapidity and azimuthal emission angle, (ii) correlations between  $dn/dy$  and  $\langle p_T \rangle$ , and (iii) fluctuations in these observables.

Also considered were the similarities and differences for collider detectors operating between 2 + 2 GeV/nucleon and 100 + 100 GeV/nucleon. One immediate comment is that if the plasma is characterized by a temperature, say  $T = 200$  MeV, the average energies of particles emitted from such a thermal source will be relatively low (e.g.,  $\pi$ 's  $\approx 500$  MeV,  $K$ 's  $\approx 400$  MeV). This means that the detector (particularly at mid-rapidity) will generally be sampling soft hadrons. This puts an added burden on calorimetry for these particles. In addition, the relatively low energy reduces the survival probability for those particles which are unstable (e.g.,  $\sim 88\%$  of the pions produced from a 200 MeV plasma will survive a 3 meter flight path and  $\sim 52\%$  of the kaons).

The group's general aim was to define a relatively simple collider detector, one employing tracking over a limited solid angle while providing calorimetry over the remaining nearly  $4\pi$ . In this scheme, the target/projectile fragmentation regions were not considered, since at collider energies most of the fragmentation products remain inside the beam pipe. Figure 11 shows the layout of a collider detector. It consists of the following elements: (i) a multiplicity barrel surrounding the interaction region capable of measuring  $dn/d\eta$  with good accuracy, (ii) electromagnetic and hadronic calorimetry over at least the central two units of rapidity ( $40^\circ \lesssim \theta_{c.m.} \lesssim 140^\circ$ ), and (iii) an open region into which one could place either a visual detector like a streamer chamber or a charged particle spectrometer with the ability to track up to 20 particles. The general philosophy

L.S. SCHROEDER

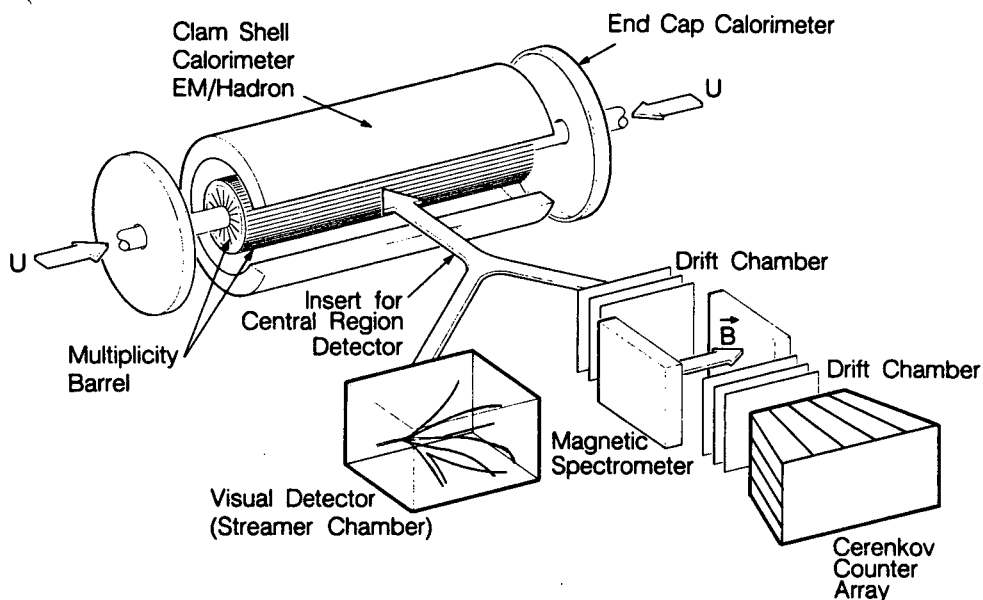

FIGURE 11 Possible collider detector.

was to use the calorimetry section for triggering (high  $p_T$  or  $E_T$ ) and the streamer chamber or spectrometer arm for measuring single and few particle correlations. The capabilities of a streamer chamber are well known for relatively high multiplicity events and for observing decays of unstable particles like  $\Lambda^0 \rightarrow p\pi^-$ . The magnetic spectrometer arm would have to possess good tracking and particle identification capabilities. Note that the bending will be in the vertical plane, allowing equal acceptance for positive and negative particles. Such a device, concentrating on the physics of the central region, should have a large dynamic range of operation, i.e., work as well at a few GeV/nucleon as at tens of GeV/nucleon, since the plasma once achieved should be characterized by a single temperature (relatively independent of incident energy).

The group performed a simple Monte Carlo study of the magnetic spectrometer arm's acceptance for HBT experiments.



## REVIEW OF 1984 LBL DETECTOR WORKSHOP

They assumed: (i)  $10^5$  pairs needed to provide a sensitivity of  $\Delta$  (radius)  $\approx 0.2$  fm,  $\Delta$  (lifetime)  $\approx 0.7$  fm/c, and  $\Delta$  (intercept-degree of coherence)  $\approx 0.1$ ; (ii) luminosity ( $\mathcal{L}$ ) of  $10^{24}$   $\text{cm}^{-2}\text{sec}^{-1}$  for uranium-uranium collisions; and (iii) rate  $\propto \sigma \mathcal{L}(\text{dn/dy})^2$ . From the Monte Carlo they obtained  $1.5 \times 10^4$  like sign  $\pi$ -pairs/day, so that about one week's run would provide detailed HBT information.

### 9. CONCLUSIONS

Several lessons were learned from the Workshop, including:

1. Experiments are do-able, but: (i) in high flux environment one will probably have to give up tracking all particles and go to calorimetry, (ii) selective tracking will be required (e.g., to distinguish between multiple interaction vertices in collider experiments).

2. R&D issues identified: (i) particle identification (thin TPC's, RICH, TRD (Transition Radiation Detectors)), (ii) low mass detectors needed to reduce conversions of  $\gamma$ -rays ( $\gamma \rightarrow e^+e^-$ ), secondary interactions, and production of  $\delta$ -rays (particularly by high-Z projectiles) that can produce a soft background in detectors and decrease spatial resolution of drift/wire chambers, and (iv) use and development of high technology items (e.g., Li-strip detectors).

3. Need for input from high energy physics: (i) both their interest and participation, (ii) experience and expertise with large detectors such as UA1 allows us to obtain information on tracking algorithms, pattern recognition problems, and how to calibrate large-scale systems.

4. More theoretical work needed on question of signatures of the quark-gluon plasma (QGP)--theorist's R&D.

L.S. SCHROEDER

## 10. ACKNOWLEDGMENTS

I want to express my appreciation to the Organizing Committee of this Conference for inviting me to speak. Special thanks to the conveners at the LBL Detector Workshop; without their considerable efforts, the Workshop would not have been the success it was.

## REFERENCES

1. Proceedings of the Workshop on Detectors for Relativistic Nuclear Collisions, edited by L.S. Schroeder, LBL-18225 (September 1984).
2. L.S. SCHROEDER, Detectors for High Energy Nucleus-Nucleus Collisions, LBL-18310 (August 1984), to be published in the Proceedings of the Quark Matter '84 Meeting, held in Helsinki, Finland, June 17-21, 1984.
3. A Long Range Plan for Nuclear Science, A report by the DOE/NSF Nuclear Science Advisory Committee, (December 1983).
4. RHIC and Quark Matter, Proposal for a Relativistic Heavy Ion Collider at Brookhaven National Laboratory, BNL-35237 (August 1984).
5. L.S. SCHROEDER, The Berkeley Mini-Collider, LBL-17990 (June 1984), to be published in the Proceedings of the Conference on the Intersections Between Particle and Nuclear Physics, held in Steamboat Springs, Colorado, May 23-30, 1984.
6. G.R. YOUNG, J.A. MARTIN, and J.B. BALL, Nucl. Phys. A418, 361 (1984).
7. See detector related sections of the Proceedings of the Bielefeld Workshop, Quark Matter Formation and Heavy Ion Collisions, edited by M. Jacob and H. Satz, (World Scientific, Singapore, 1982).
8. See detector related sections in the Proceedings of the Third International Conference on Ultra-Relativistic Nucleus-Nucleus Collisions (Brookhaven, September 1983), edited by T.W. Ludlam and H.E. Wegner, published in Nucl. Phys. A418 (1984).
9. See detector related sections in the Proceedings of the Workshop on SPS Fixed Target Physics in the Years 1984-1989, Vol. I and II, edited by J. Mannelli, CERN 83-02 (February 10, 1983).

REVIEW OF 1984 LBL DETECTOR WORKSHOP

10. M. GUYLASSY, Nucl. Phys., A418, 59 (1984).
11. L. McLERRAN, Signatures for New Phenomena, to be published in the Proceedings of the Quark Matter '84 Meeting, held in Helsinki, Finland, June 17-21, 1984.
12. The conveners were: Fixed Target: Hadrons--C. Gruhn (LBL), I. Otterlund (Lund); Event Parameters--K. Foley (BNL), and A. Poskanzer (LBL); Penetrating Probes--J. Carroll (UCLA), M. Goldberg (Syracuse); Collider: Hadrons and Event Parameters--W. Carithers (LBL), T.J.M. Symons (LBL), G. Young (ORNL); Penetrating Probes--T. Ludlam (BNL), L. Madansky (Johns Hopkins).
13. T.M. BURNETT et al., Phys. Rev. Lett., 50, 2062 (1983).
14. C. GRUHN et al., SPS Proposal, CERN/SPSC 84-13 (1984).
15. J. RAFELSKI and M. DANOS, GSI-83-6 (1983) and references therein.
16. T. LUDLAM, private communication.
17. T. LUDLAM, F. PAIGE, L. MADANSKY, Very High Energy Probes of the Quark-Gluon Plasma, Proceedings of the Workshop on Detectors for Relativistic Nuclear Collisions (Ref. 1 above), p. 115.

This report was done with support from the Department of Energy. Any conclusions or opinions expressed in this report represent solely those of the author(s) and not necessarily those of The Regents of the University of California, the Lawrence Berkeley Laboratory or the Department of Energy.

Reference to a company or product name does not imply approval or recommendation of the product by the University of California or the U.S. Department of Energy to the exclusion of others that may be suitable.

TECHNICAL INFORMATION DEPARTMENT  
LAWRENCE BERKELEY LABORATORY  
UNIVERSITY OF CALIFORNIA  
BERKELEY, CALIFORNIA 94720