

UC Irvine

SSOE Research Symposium Dean's Awards

Title

2018 AIAA Design/Build/Fly (Low Aspect Ratio Plate Aircraft)

Permalink

<https://escholarship.org/uc/item/7dq74644>

Authors

Luu, Ryan
Macias, Carlos
Torres, Karen
et al.

Publication Date

2018-03-15

Peer reviewed

What is Design/Build/Fly?

Design/Build/Fly is an annual competition sponsored by the AIAA, Textron, and Raytheon that challenges students to design, manufacture and optimize an aircraft to meet competition requirements

Goals and Objectives

- Develop the engineering, teamwork, and communication skills
- Optimize the aircraft through an iterative process of aircraft development and testing
- Continue to document all processes related to operations, management, design, development and optimization
- Develop an aircraft that is able to yield the highest score at the 2018 AIAA DBF Competition

Flight Course

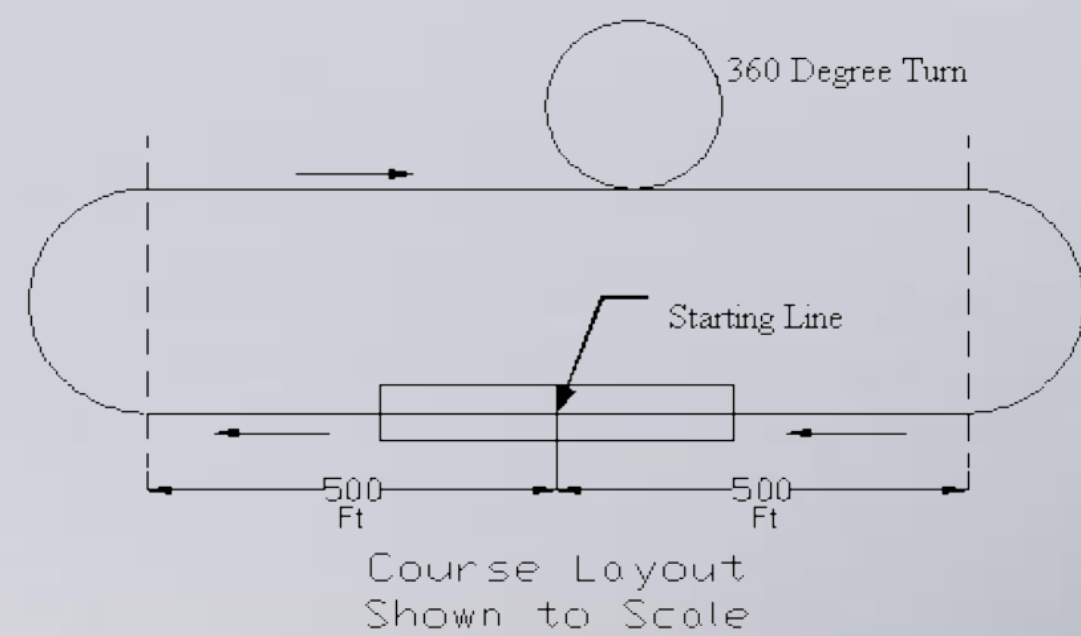

Competition Mission Objectives

Ground Mission	Mission 1
Removal and replacement of two Line Replaceable Units (LRUs)	Complete three laps without payload within five minutes
Mission 2	Mission 3
Complete three laps with "passengers" as quickly as possible	Complete as many laps as possible with cargo and passengers in under ten minutes

Requirements

- Must take off in under 150 feet
- Must use NiMh or NiCad batteries
- Must have LRUs
- Low empty weight
- Short wingspan

Timeline

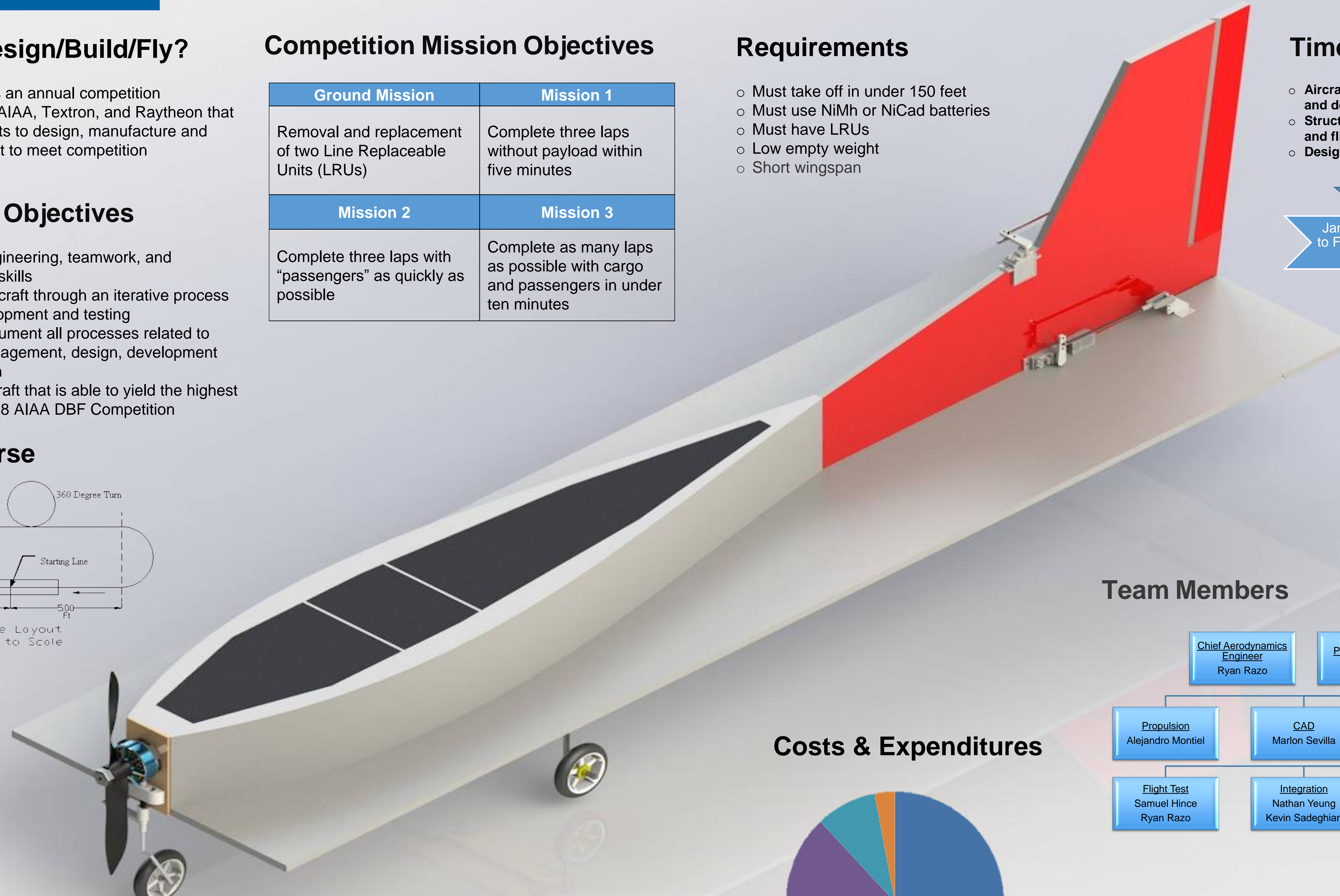
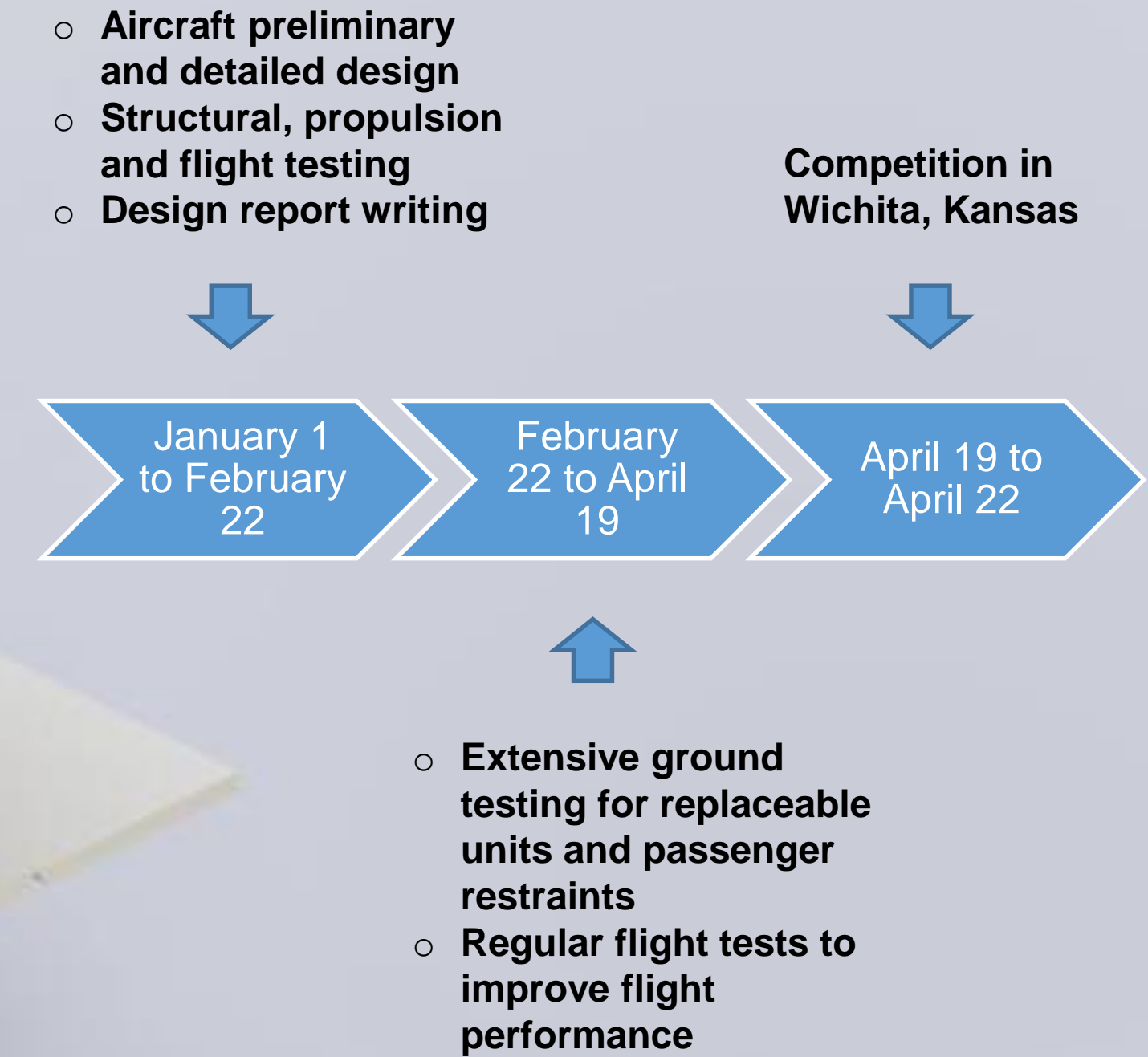

Team Members

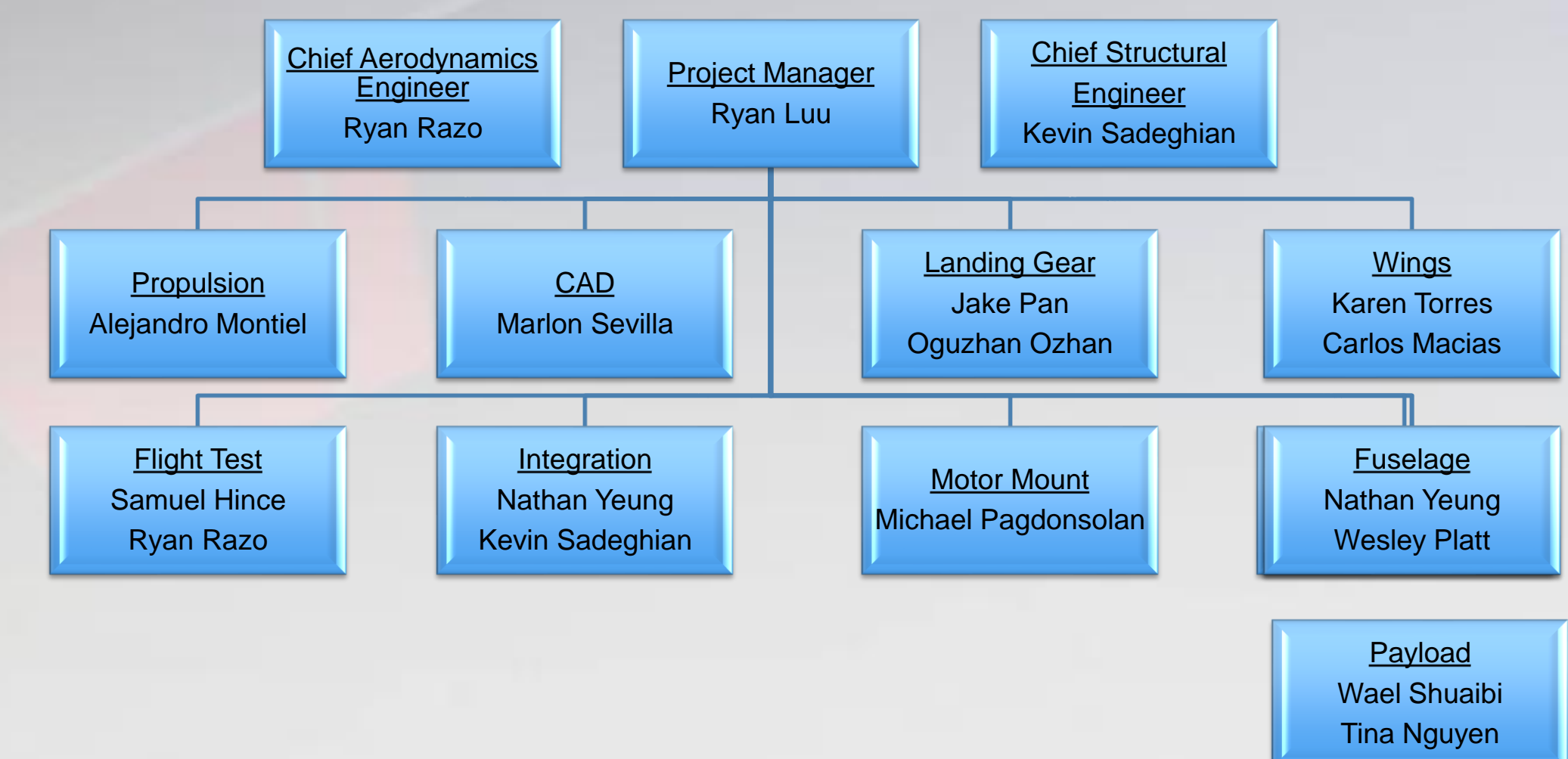

Costs & Expenditures

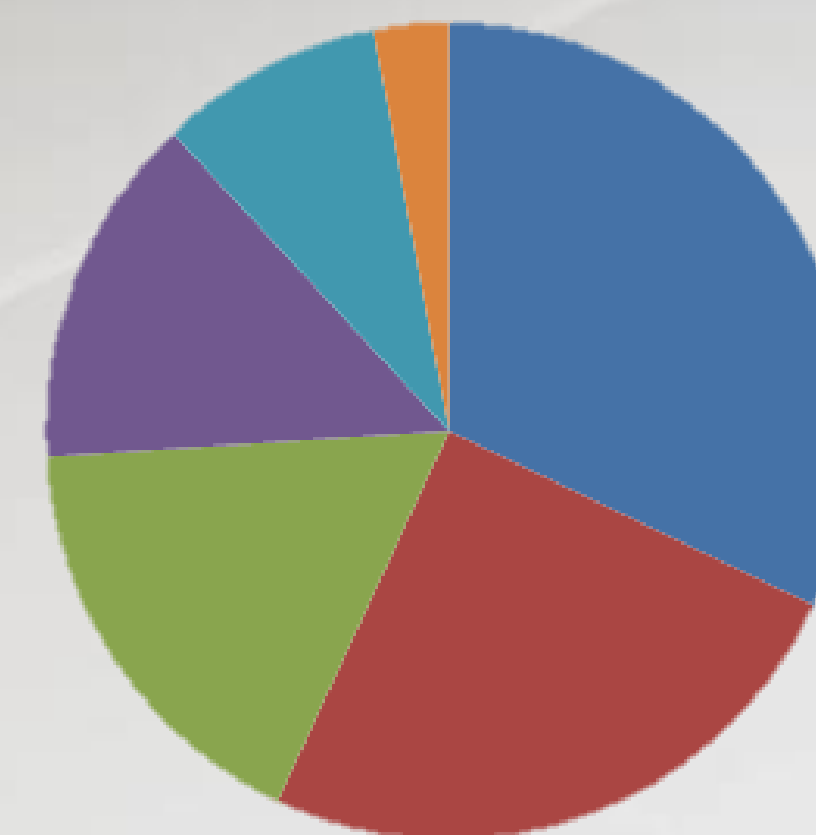

- Electronics
- Fabrication Materials
- Transportation
- Tooling
- Housing
- Off the Shelf Components

Grand Total: \$4,804.09

Contact the DBF Team

Project Manager: Ryan Luu (rnluu@uci.edu)
 Co-Chief Engineer: Ryan Razo (rrazo@uci.edu)
 Co-Chief Engineer: Kevin Sadeghian (ksadeghi@uci.edu)
 Email: dbfuci2017@gmail.com
 Facebook: <https://www.facebook.com/dbfuci/>
 For more information, visit: www.aiaadbf.org

