

Lawrence Berkeley National Laboratory

Recent Work

Title

PROCESS EVALUATION UNIT (PEU) OPERATING MANUAL

Permalink

<https://escholarship.org/uc/item/7q8997jw>

Author

Figueroa, C.

Publication Date

1981



Lawrence Berkeley Laboratory

UNIVERSITY OF CALIFORNIA

ENERGY & ENVIRONMENT DIVISION

PROCESS EVALUATION UNIT (PEU) OPERATING MANUAL

C. Figueroa

January 1981

For Reference

Not to be taken from this room

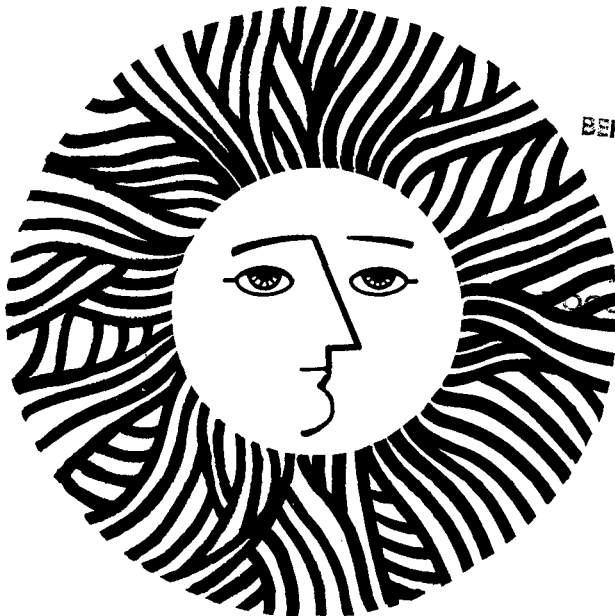

RECEIVED
LAWRENCE
BERKELEY LABORATORY

MAR 24 1981

LIBRARY AND
DOCUMENTS SECTION

PUB-3013 c.1

DISCLAIMER

This document was prepared as an account of work sponsored by the United States Government. While this document is believed to contain correct information, neither the United States Government nor any agency thereof, nor the Regents of the University of California, nor any of their employees, makes any warranty, express or implied, or assumes any legal responsibility for the accuracy, completeness, or usefulness of any information, apparatus, product, or process disclosed, or represents that its use would not infringe privately owned rights. Reference herein to any specific commercial product, process, or service by its trade name, trademark, manufacturer, or otherwise, does not necessarily constitute or imply its endorsement, recommendation, or favoring by the United States Government or any agency thereof, or the Regents of the University of California. The views and opinions of authors expressed herein do not necessarily state or reflect those of the United States Government or any agency thereof or the Regents of the University of California.

PUB-3013

PROCESS EVALUATION UNIT (PEU) OPERATING MANUAL.

Figueroa, C. (LBL) Jan. 1981. 11 p.

c.1 Ref.

c.2 3-24-81

PUB-3013

PROCESS EVALUATION UNIT (PEU) OPERATING MANUAL.
Figueroa, C. (LBL) Jan. 1981. 11 p.

c.1 Ref.

c.2 3-24-81

PROCESS EVALUATION UNIT (PEU)

OPERATING MANUAL

C. Figueroa
Lawrence Berkeley Laboratory
University of California
Berkeley, California 94720

January 1981

This work was supported by the Assistant Secretary for Conservation and Solar Energy, Office of Solar Applications for Industry, Biomass Energy Systems Division of the U.S. Department of Energy under Contract No. W-7405-ENG-48.

This work was funded through Battelle Pacific Northwest Laboratory, Lead Laboratory for the U.S. Department of Energy, Biomass Energy Systems Division, Thermochemical Conversion Program under contract No. DE-AC06-76RLO 1830.

PROCESS EVALUATION UNIT

The operating manual described in this report was written for the Process Evaluation Unit (PEU) which was designed and constructed by Lawrence Berkeley Laboratory for the Department of Energy.

The purpose of the PEU is to efficiently test new biomass liquefaction process concepts in a continuous fashion on a bench scale. The PEU consists of the following:

- (1) weighed, recirculating feed system
- (2) mass-controlled gas feed system
- (3) tubular reactor
- (4) product collection system
- (5) off-gas automatic analysis
- (6) central data logger and controller.

The simplicity of the PEU will allow examination of a wide range of process conditions as well as different process configurations.

OPERATING MANUAL

CONTENTS	PAGE
I. START UP	1
A. Check List	1
B. Pressure Test	3
C. Gas Supply Build-up	3
D. Gas and Water Flows	3
E. Heat Tracing	5
II. LIQUEFACTION MODE	5
A. Reactor Heat-up	5
B. Steady State (Water/Gas Only)	5
C. Biomass Liquefaction	5
D. Product Collection Method	6
E. Data Collection	6
III. SHUT DOWN	6
A. Normal	6
B. Emergency	9
IV. INTERLOCKS, SAFETY, AND TRAINING	11

I. START-UP

A. CHECKLIST (Start-Up)

1. Minimum gas supply and slurry requirements
 - a. 4 - High pressure nitrogen cylinders (6,000 psi)
 - b. 4 - Low pressure reducing gas cylinders
 - c. 100 pounds of freshly refined slurry
2. Visually inspect all lines, valves, vessels, and electrical connections.
3. Switch cooling water on to compressors.
4. Check air supply pressures.
 - a. 20 psi to main back pressure control valve
 - b. 100 psi to on/off air operated valves
5. Electrical supply on
6. Check correct operation of air operated valves.
7. Computer on
 - a. List program and compare to previous listing for changes.
 - b. Inspect data listing for temperatures and pressures for unusual readings.
 - c. Test interlocks for pump and compressors
8. Charge the slurry to the hold tank and begin recirculation.
9. Prime high pressure pump with water.
10. Set-up gas chromatograph according to the following instructions:

G. C. Carle - Gas Analysis Procedure

1. Set Helium (He) supply at 50 psi; set Nitrogen (N₂) regulator at 60 psi.
2. Use soap bubble flow meter to establish that gas is purging the system as measured at ports "X" and "N₂exhaust."
3. Turn on data station and allow to warm up.
4. Turn on upper and lower power switches. Upper: set column temperature at 75°C. Lower: turn switch to ON and set temperature. Adjust control at 60 (600°C). Note: never allow setting to exceed 70.
5. Allow 30-45 minutes for temperature equilibration.
6. Initialize G.C. data station program.
7. Follow instruction [AGC-111 (Filaments)] on G.C. instruction manual.
8. Carrier gas flow rates
 - a. N₂: 40-60 ml/min. (adjust by means of regulation).
 - b. He: adjust flow at port X (V₁=1; V₂=1) to 28 ml/min. (21-22 sec.) by means of regulator.
 - Then V₂=2, adjust restrictor A for same flow.
 - Measure flow at port Y, adjust restrictor B for same flow again (V₂=1).
9. Press "Ready" button to inject sample.
10. Press "Inject" button for sample. The G.C. will cycle for 12 minutes until the machine is ready for the next sample.

Shutdown Procedure (G.C.)

- 1A. If planning to use again within 24 hours, turn bridge setting to OFF, output to test, and carrier gas pressures to approximately 10 psig.

CAUTION: It will take at least 30 minutes before pressure in carrier gas lines will become stabilized. Do not leave until you are sure that gas flow has stabilized.

- 1B. If not planning to use again within 24 hours, turn both power switches OFF. Stabilize carrier gas flow at approximately 10 psig as above. Carrier gas may be shut off the next day.

B. Pressure Test

1. 100 psi nitrogen pressure test
2. 1000 psi nitrogen pressure test
3. 3000 psi nitrogen pressure test
 - a. Isolate sections and monitor for leaks overnight.
 - b. Estimate leak rate.

C. Gas Supply Build-up

1. Depressurize gas surge vessel (see figure 1) and supply lines.
2. Introduce reducing gas at 200 psi.
3. Open supply valves.
4. Switch on compressor to electronic control. Compressors are now on automatic control from computer.
5. Wait until the compressor shuts off at 4000 psi. The gas feed supply is now ready.

D. Gas/Water Flows

1. Switch pump on to desired flow.
 - a. Verify flow by deadheading pump and by monitoring pressure increase.
2. Set the thermal mass flowmeter for desired mass flowrate of gas.

ENGINEERING NOTE

SUBJECT

FIG 1

NAME
CARLOS FZS
DATE
8-15-80

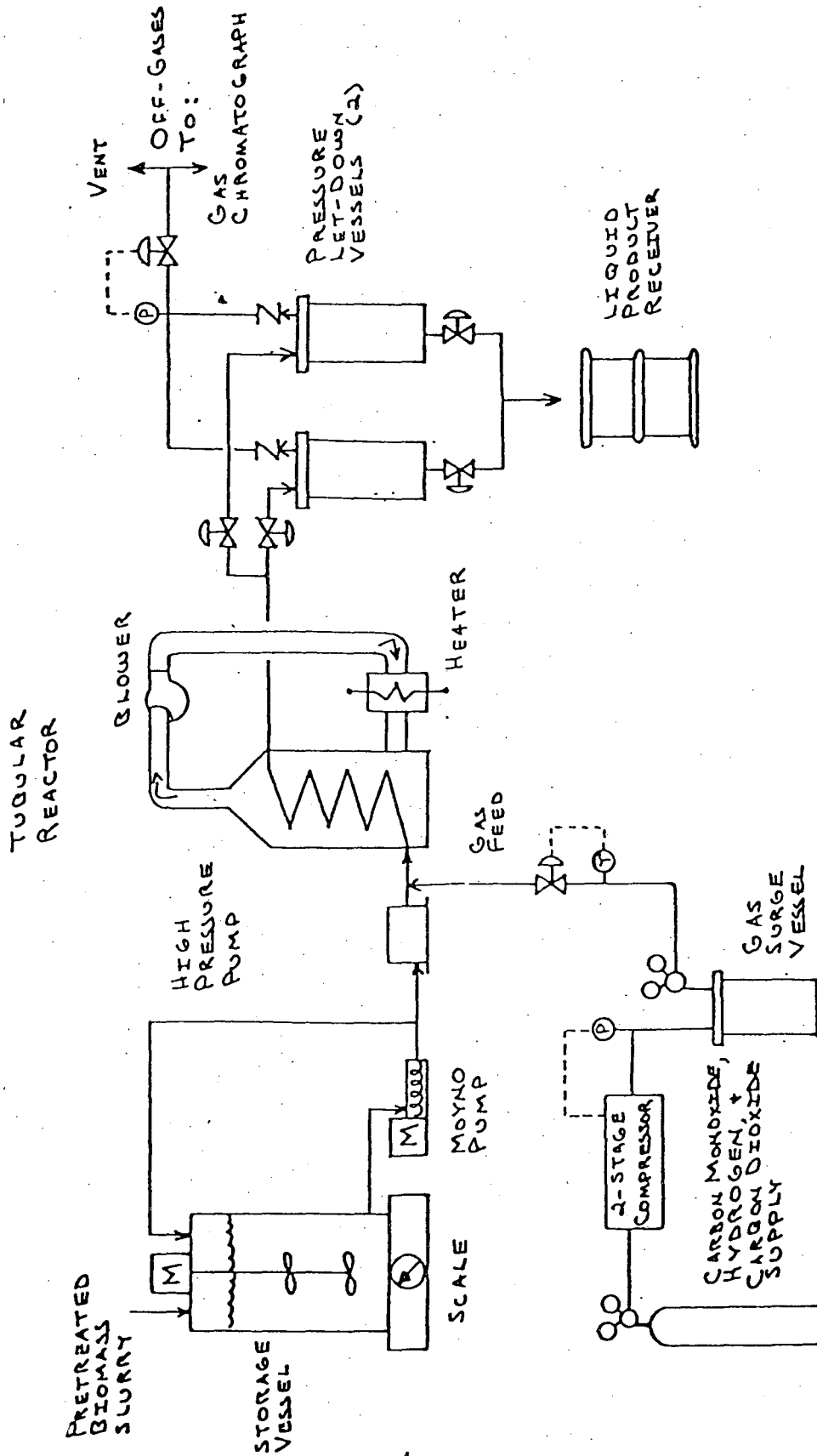

LBL PROCESS EVALUATION UNIT (PEU)

3. Open gas feed lines to the reactor inlet. Turn surge tank gas regulator to supply thermal mass flowmeter at 3200 psi.
4. Switch automatic back pressure controller on.
5. Verify gas flow from dry test meter.
6. Water and reactant gas flow are now established.

E. Heat Tracing

1. Turn on heat tracing to 300^oF for:
 - a. Back pressure control valve and check valves.
 - b. Depressurization and pressurization valves for let-down vessels.

II. LIQUEFACTION MODE

A. Reactor Heat-Up

1. Turn on heat fan.
2. Close butterfly cooling valves.
3. Turn on heaters.

B. Steady State (initial)

1. Wait for steady pressures and temperatures to be reached.
 - a. Reactor outlet (selected)
 - b. Input temperature to pressure vessels: 300^oF
 - c. Pressure let-down vessel: 250^oF

C. Biomass Liquefaction

1. Switch pump feed from water to slurry.
2. Monitor system until steady state is reach.

D. Product Collection Method

1. Description

Liquid product is collected in one of two 2-gallon pressure vessels. Once 50-80% of a vessel is filled, the vessel is isolated, depressurized, purged, emptied of product, and repressurized for the next cycle.

2. Valve sequence for product collection: (See Table I and Figure II.)

E. Data Collection

1. Temperatures and pressures are recorded automatically by the central data logging system.
2. Record weight of slurry tank before and after any steady state collection period.
3. Operate gas chromatograph every 15 minutes. Gas chromatograph is automated to complete an analysis in 12 minutes.
4. Record ambient air concentrations of carbon monoxide and hydrogen.
5. Record weight of collected liquid product and off-gas dry test gas meter total cubic feet.

III. SHUTDOWN

A. Normal

1. Switch from slurry to water supply.
2. Switch from reducing gas to nitrogen supply.
3. Open butterfly valves for reactor cool-down.
4. Continue until all slurry, oil and $H_2 + CO$ are purged from the system.
5. When the system is purged and cool; depressure the whole system and turn off all gas, water, and electrical supplies.

ENGINEERING NOTE

SUBJECT

VALVE SEQUENCE FOR PRODUCT COLLECTION

NAME

DATE

I. NORMAL OPERATION

	VALUE LOCATION							
	A	B	C	D	E	F	G	H
1) PVI Product Collection	O	C	C	C	C	C	C	C
2) Open PVI (full PVI)	O	O	C	C	C	C	C	C
3) Isolate PVI (fill PVI)	C	O	C	C	C	C	C	C
4) Depressurize PVI	C	O	O	C	O	C	C	C
5) Purge PVI (low P N ₂)	C	O	C	O	O	C	C	C
6) Repeat 4) + 5) Several Times								
7) Pressure PVI (20psi N ₂)	C	O	C	O	O	C	C	C
8) Isolate PVI	C	O	C	C	C	C	C	C
9) Discharge PVI	C	O	C	C	C	C	O	C
10) Repeat 7) - 9)								
11) Isolate PVI	C	O	C	C	C	C	C	C
12) Pressure PVI (3000psi N ₂)	C	O	C	O	O	C	C	C
+ Isolate PVI	C	O	C	C	C	C	C	C
13) PVI Ready for collection								
14) Open PVI	O	O	C	C	C	C	C	C
15) Isolate PVI	O	C	C	C	C	C	C	C
16) Depressure PVI	O	C	O	C	C	O	C	C
17) Purge PVI (low P N ₂)	O	C	C	O	C	O	C	C
18) Repeat 16) + 17) Several Times								
19) Pressure PVI (20psi N ₂)	O	C	C	O	C	O	C	C
20) Isolate PVI	O	C	C	C	C	C	C	C
21) Discharge PVI	O	C	C	C	C	C	C	O
22) Repeat 19) - 21)								
23) Pressure PVI (3000psi N ₂)	O	C	C	O	C	O	C	C
24) Isolate PVI	O	C	C	C	C	C	C	C

Go To 1) ↑

FIGURE II.

ENGINEERING NOTE

SUBJECT

PRODUCT COLLECTION SYSTEM

NAME

DATE

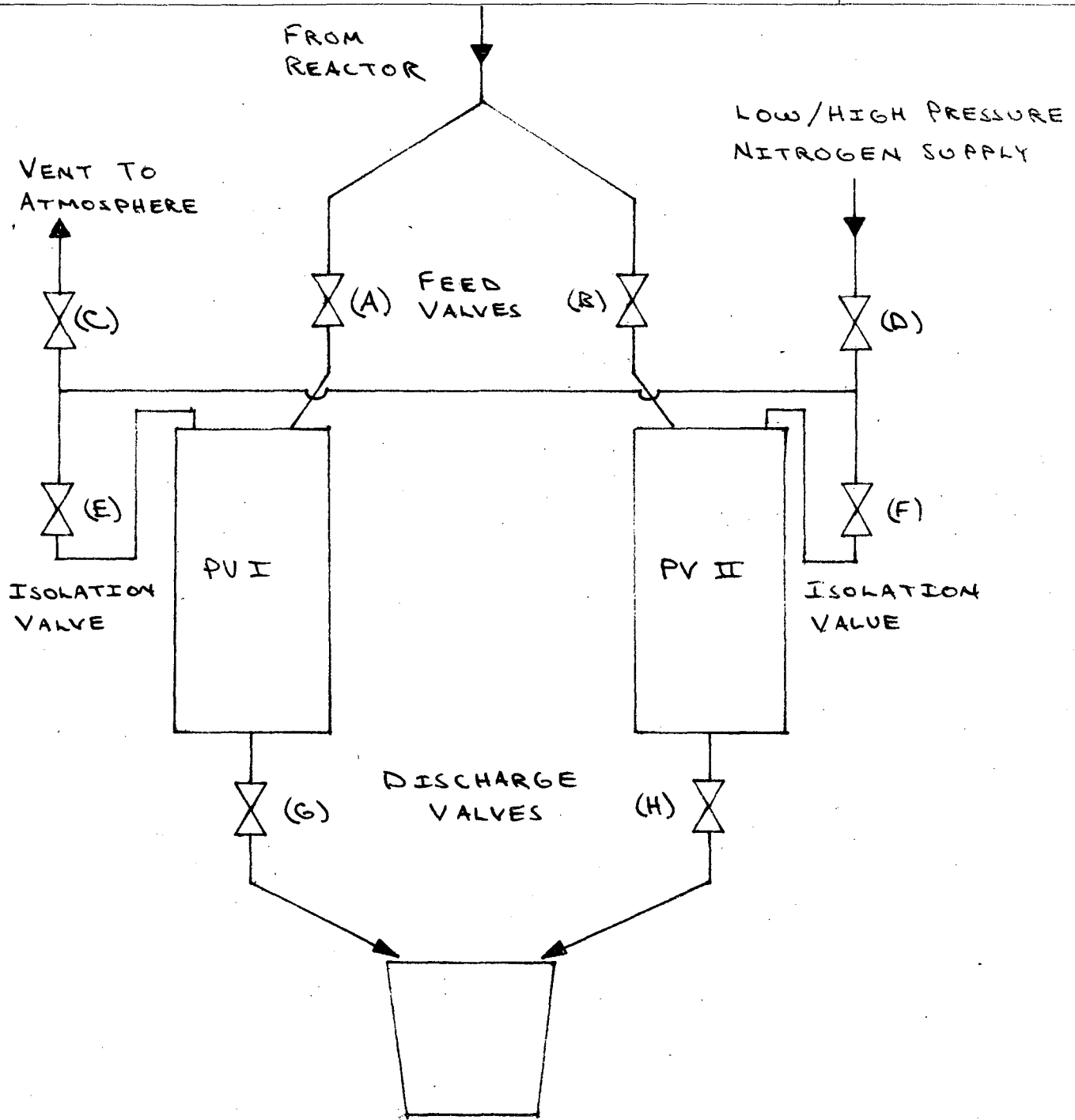

B. Emergency Shutdown Mode

1. General Emergency Shutdown Procedure

- a. Switch compressor feed to N_2
- b. Switch pump feed to H_2O
- c. Turn off air heater
- d. Open cold air feed and exhaust valves in air recirculation system
- e. Close hot air bypass valve
- f. Turn off moyno pump and stirrer
- g. In case of failure of individual units in 1-6 above, see specific system instruction.

2. Slurry Feed System

a. pressure crisis

- i. Switch pump feed to H_2O
- ii. Exit pressure exceeds 100 psi (stable operation = 60-80 psi)
 - Open and close bypass valve twice to break clog near pump exit.
 - Activate N_2 Blowout system for clogs far from exit.
- iii. Exit pressure heat disappears
 - Check pump seals.
 - Be sure bypass valve is closed.Plunger through throat to unclog feed line

b. Slurry feed system electrical crisis

- i. Pump failure to start
 - Check wall circuit breaker
 - Check wall cord
 - Check reset of thermal fuses
 - Check pressure
 - Check reset of pressure relay
 - Check solder points

c. Pump failure after start

- Switch pump to H₂O
- Check all items in list above
- Replace slurry feed if pumping resumes
- Discontinue run if unable to resume pumping.
(Emergency Shutdown)

3. Gas Supply System

a. Pressure crisis

- i. Cyclic on-off operation expected at operating pressure
 - Computer shut off at 4000 psi and turns on at 3500 psi.
- ii. If pressure is exceeded and computer does not shut off, alarm should sound.
- iii. Switch pump feed to H₂O.
- iv. Shut off computer manually and switch to N₂.
 - Turn off reducing gas feed
 - Turn on high pressure N₂ feed to correct flow.
- v. No flow indicates plugged gas feed line.
 - Shut off N₂ and follow general shutdown procedure.
 - Dismantle line to locate plug.
- vi. If under pressure condition occurs, computer will also shut off compressors.

b. Temperature crisis

- i. Monitor exit temperature of coolant fluid.
- ii. Double flow until exit H₂O temperature $\leq 40^{\circ}\text{C}$ (100°F).
- iii. Monitor exit gas temperature coolant flow for $T > 150^{\circ}\text{C}$.

IV. INTERLOCKS, SAFETY, AND TRAINING

A. Interlocks

1. High pressure feed pump electronic over pressure protection
2. The compressor(s) system have a low pressure gas supply automatic shut-off interlock as well as an over pressure shut-off.
3. The reactor heater controller has an over temperature interlock.

B. Safety

1. The high pressure lab contains a pair of independent ambient air monitors for carbon monoxide and hydrogen. (March 1981 installation)
 - a. One CO/H₂ set is located above the equipment.
 - b. The second set is located in the laboratory away from the experiment.

C. Training

1. All operating personnel shall be thoroughly trained on the system with water and nitrogen initially.
2. All personnel shall wear safety clothing, eye protection at all times. Lab courses in CPR and high pressure equipment operation, and breathing gear usage shall be mandatory.

This report was done with support from the Department of Energy. Any conclusions or opinions expressed in this report represent solely those of the author(s) and not necessarily those of The Regents of the University of California, the Lawrence Berkeley Laboratory or the Department of Energy.

Reference to a company or product name does not imply approval or recommendation of the product by the University of California or the U.S. Department of Energy to the exclusion of others that may be suitable.

TECHNICAL INFORMATION DEPARTMENT
LAWRENCE BERKELEY LABORATORY
UNIVERSITY OF CALIFORNIA
BERKELEY, CALIFORNIA 94720