

MOCHE TOMBS at DOS CABEZAS



Christopher B. Donnan

MOCHE TOMBS
at
DOS CABEZAS

MOCHE TOMBS
at
DOS CABEZAS

Christopher B. Donnan

COTSEN INSTITUTE OF ARCHAEOLOGY AT UCLA
MONOGRAPH 59

The Cotsen Institute of Archaeology at UCLA is a research unit at the University of California, Los Angeles that promotes the comprehensive and interdisciplinary study of the human past. Established in 1973, the Cotsen Institute is a unique resource that provides an opportunity for faculty, staff, graduate students, research associates, volunteers and the general public to gather together in their explorations of ancient human societies.

Former President and CEO of Neutrogena Corporation Lloyd E. Cotsen has been associated with UCLA for more than 30 years as a volunteer and donor and maintains a special interest in archaeology. Lloyd E. Cotsen has been an advisor and supporter of the Institute since 1980. In 1999, The UCLA Institute of Archaeology changed its name to the Cotsen Institute of Archaeology at UCLA to honor the longtime support of Lloyd E. Cotsen.

Cotsen Institute Publications specializes in producing high-quality data monographs in several different series, including Monumenta Archaeologica, Monographs, and Perspectives in California Archaeology, as well as innovative ideas in the Cotsen Advanced Seminar Series and the Ideas, Debates and Perspectives Series. Through the generosity of Lloyd E. Cotsen, our publications are subsidized, producing superb volumes at an affordable price.

The Cotsen Institute of Archaeology at UCLA
Charles Stanish, Director
Elizabeth Klarich, Assistant Director
Shauna K. Mecartea, Executive Editor & Media Relations Officer
Eric C. Gardner, Publications Coordinator

Editorial Board of the Cotsen Institute of Archaeology
Jeanne E. Arnold, Christopher B. Donnan, Shauna K. Mecartea, John K. Papadopoulos, James Sackett, and Charles Stanish

Editorial Advisory Board
Chapurukha Kusimba, Joyce Marcus, Colin Renfrew, and John Yellen

This book is set in 12-point Columbus, with titles in 40-point Columbus.
Edited by Marjorie Pannell
Designed by Christopher B. Donnan
Index by Donald McClelland

Cotsen Institute of Archaeology at UCLA
308 Charles E. Young Drive North
A163 Fowler
Los Angeles, CA 90095-1510

Requests for permission to reproduce material from this work should be sent to the Cotsen Institute of Archaeology at UCLA at the above address.

Printed and bound in Hong Kong by South Sea International Press Ltd.

Library of Congress Cataloging-in-Publication Data

Donnan, Christopher B.
Moche tombs at Dos Cabezas / Christopher B. Donnan.
p. cm. -- (Monograph / Cotsen Institute of Archaeology at University of California ; 59)
Includes bibliographical references and index.
ISBN 978-1-931745-51-2 (pbk. : alk. paper) -- ISBN 978-1-931745-52-9 (cloth : alk. paper)
1. Dos Cabezas Site (Peru) 2. Mochica Indians--Peru--Jequetepeque River Valley--Antiquities. 3. Mochica Indians--Funeral customs and rites--Peru--Jequetepeque River Valley. 4. Mochica pottery--Peru--Jequetepeque River Valley. 5. Excavations (Archaeology)--Peru--Jequetepeque River Valley. 6. Tombs--Peru--Jequetepeque River Valley. 7. Grave goods--Peru--Jequetepeque River Valley. 8. Elite (Social sciences)--Peru--Jequetepeque River Valley. 9. Jequetepeque River Valley (Peru)--Antiquities. I. Cotsen Institute of Archaeology at UCLA. II. Title.
F3430.1.M6D69 2007
985'.14--dc22

2007036310

Copyright © 2007 Regents of the University of California
All rights reserved. Printed in the USA.



MONOGRAPHS

Contributions in Field Research and Current Issues in Archaeological Method and Theory

- MO05 *The Archaeology of Oak Park, Ventura County, California*
- MO06 *Obsidian Dates II: A Compendium of Obsidian Hydration Determinations Made at the UCLA Obsidian Hydration Laboratory*
- MO07 *History and Prehistory at Grass Valley, Nevada*
- MO08 *Papers on the Economy and Architecture of the Ancient Maya*
- MO09 *The Late Minoan I Destruction of Crete: Metal Groups and Stratigraphic Considerations*
- MO10 *Rock Art of East Mexico and Central America: An Annotated Bibliography*
- MO11 *The Archaeology of Oak Park, Ventura County, California*
- MO12 *The Running Springs Ranch Site: Archaeological Investigations at VEN-65 and VEN-261*
- MO13 *Archaeological Investigations at the Ring Brothers Site Complex, Thousand Oaks, California*
- MO14 *Papers in Cycladic Prehistory*
- MO15 *Inland Chumash Archaeological Investigations*
- MO16 *Obsidian Dates III: A Compendium of Obsidian Hydration Determinations Made at the UCLA Obsidian Hydration Laboratory*
- MO17 *Excavations in Northern Belize, Central America*
- MO18 *Studies in Cypriote Archaeology*
- MO19 *Prehistoric Indian Rock Art: Issues and Concerns*
- MO20 *Messages from the Past: Studies in California Rock Art*
- MO21 *Pictographs and Petroglyphs of the Oregon Country, Part 1*
- MO22 *The Archaeology of Two Northern California Sites*
- MO23 *Pictographs and Petroglyphs of the Oregon Country, Part 2*
- MO24 *Pots and Potters: Current Approaches in Ceramic Archaeology*
- MO25 *Prehistoric Production and Exchange in the Aegean and Eastern Mediterranean*
- MO26 *Excavations at Mission San Antonio 1976-1978*
- MO27 *Andean Archaeology, Papers in Memory of Clifford Evans*
- MO28 *Archaeological Field Research in the Upper Mantaro, Peru, 1982-1983: Investigations of Inka Expansion and Exchange*
- MO29 *Obsidian Dates IV: A Compendium of Obsidian Hydration Readings from the UCLA Obsidian Hydration Laboratory*
- MO30 *Archaeology of the Three Springs Valley, California. A Study in Functional Cultural History*
- MO31 *Investigaciones Arqueológicas de la Costa Sur de Guatemala*
- MO32 *Western Pomo Prehistory: Excavations at Albion Head, Nightbirds' Retreat and Three Chop Village, Mendocino County, California*
- MO33 *Girikibaciyan: A Halafian Site in Southeastern Turkey*
- MO34 *Settlement Archaeology of Cerro de las Mesas, Veracruz, Mexico*
- MO35 *Pottery of Prehistoric Honduras: Regional Classification and Analysis*
- MO36 *New Light on Old Art: Recent Advances in Hunter-Gatherer Rock Art Research*
- MO37 *Hawaiian Adze Production and Distribution: Implications for the Development of Chiefdoms*
- MO38 *Approaches to the Historical Archaeology of Mexico, Central and South America*
- MO39 *Recent Advances in the Archaeology of the Northern Andes. In Memory of Gerardo Reichel-Dolmatoff*
- MO40 *Prehistory of Agriculture: New Experimental and Ethnographic Approaches*
- MO41 *Rethinking Mycenaean Palaces: New Interpretations of an Old Idea*
- MO42 *Pompeian Households: An Analysis of the Material Culture*
- MO43 *Pottery of Postclassic Cholula, Mexico*
- MO44 *Ceramic Production and Circulation in the Greater Southwest*
- MO45 *Pathways to Prismatic Blades*
- MO46 *Domestic Ritual in Ancient Mesoamerica*
- MO47 *Archaeology in the Borderlands: Investigation in Caucasia and Beyond*
- MO48 *Yeki bud, yeki nabud: Essays on the archaeology of Iran in honor of William M. Sumner*
- MO49 *Perspectives on Ancient Maya Rural Complexity*
- MO50 *Settlement Archaeology and Political Economy at Tres Zapotes, Veracruz, Mexico*
- MO51 *Maya Zooarchaeology: New Directions in Theory and Method*
- MO52 *Archaeological Research on the Islands of the Sun and Moon, Lake Titicaca, Bolivia: Final Results from the Proyecto Tiksi Kjarka*
- MO53 *Us and Them: Archaeology and Ethnicity in the Andes*
- MO54 *Advances in Titicaca Basin Archaeology - 1*
- MO55 *Roman Foodprints at Berenike: Archaeobotanical Evidence of Subsistence and Trade in the Eastern Desert of Egypt*
- MO56 *Berenike 1999/2000*
- MO57 *Kasapata and the Archaic Period of the Cuzco Valley*
- MO58 *Moche Finesline Painting From San José de Moro*
- MO59 *Moche Tombs at Dos Cabezas*
- C. W. Clewlow, Jr., Allen Pastron, and Helen F. Wells (editors)
- C. W. Meighan and P. I. Vanderhoeven (editors)
- C. W. Clewlow, Jr., Helen F. Wells, and Richard Ambro (editors)
- Raymond Sidrys (editor)
- Hara Georgiou
- Matthias Strecker
- C. William Clewlow, Jr. and David S. Whitley (editors)
- Jack Prichett and Allen McIntyre
- C. W. Clewlow, Jr., David S. Whitley and Ellen L. McCann (editors)
- Jack L. Davis and John F. Cherry (editors)
- David S. Whitley, E. L. McCann, and C. W. Clewlow, Jr. (editors)
- Clement Meighan and Glenn Russell
- Raymond Sidrys
- Jane C. Biers and David Soren
- JoAnne Van Tilburg and Clement W. Meighan (editors)
- Clement W. Meighan (editor)
- Malcolm Loring and Louise Loring
- Delmer E. Sanburg, F. K. Mulligan, Joseph Chartkoff, and Kerry Chartkoff
- J. Malcolm Loring and Louise Loring
- Prudence Rice
- A. Bernard Knapp and Tamara Stech (editors)
- Robert L. Hoover and Julio J. Costello (editors)
- Ramiro Matos M., Solveig Turpin, Herbert Eling, Jr. (editors)
- Timothy Earle et al. (editors)
- Clement W. Meighan and Janet L. Scalise (editors)
- Brian D. Dillon and Matthew A. Boxt
- David S. Whitley and Marilyn P. Beaudry (editors)
- Thomas N. Layton
- P. J. Watson and S. LeBlanc
- Barbara Stark (editor)
- J. S. Henderson and M. Beaudry-Corbett
- D. W. Whitley and L. L. Loendorf (editors)
- Barbara Lass
- Gasco, Greg Charles Smith, and Patricia Fournier-Garcia
- Augusto Oyuela-Caycedo and J. Scott Raymond (editors)
- Patricia C. Anderson (editor)
- Michael L. Galaty and William A. Parkinson (editors)
- Penelope M. Allison
- Geoffrey McCafferty
- Donna M. Glowacki and Hector Neff (editors)
- Kenneth Hirth and Bradford Andrews (editors)
- Patricia Plunket (editor)
- Adam T. Smith and Karen S. Rubinson (editors)
- Naomi F. Miller and Kamyar Abdi (editors)
- Gyles Iannone and Samuel V. Connell (editors)
- Christopher A. Pool (editor)
- Kitty F. Emery (editor)
- Charles Stanish and Brian S. Bauer (editors)
- Richard Martin Reyecraft
- Charles Stanish, Amanda B. Cohen, and Mark S. Aldenderfer
- René T.J. Cappers
- Steven E. Sidebotham and Willeke Wendrich (editors)
- Brain S. Bauer (editor)
- Donna McClelland, Donald McClelland, and Christopher B. Donnan
- Christopher B. Donnan

TO BILL, BOB, AND ELIZABETH LENDE

CONTENTS

<i>Preface</i>	xi
CHAPTER 1 <i>Introduction</i>	1
CHAPTER 2 <i>Tomb A</i>	19
CHAPTER 3 <i>Tomb B</i>	29
CHAPTER 4 <i>Architectural Modifications</i>	41
CHAPTER 5 <i>Tomb 2</i>	65
CHAPTER 6 <i>Tomb 3</i>	149
CHAPTER 7 <i>Tomb 1</i>	169
CHAPTER 8 <i>Observations and Conclusions</i>	191
<i>Appendix Vertebrate Faunal Remains</i>	211
<i>References Cited</i>	231
<i>Index</i>	235

PREFACE

This study focuses on five Moche tombs that were excavated at the site of Dos Cabezas, on the north coast of Peru, between 1997 and 2000. My goal is to provide full documentation of the tombs and their contents, describe the chronology of construction phases for the pyramid in which they were found, and explain how these tombs expand our understanding of Moche civilization. The excavation of these tombs is only part of the work that was accomplished at Dos Cabezas in the eight field seasons that we worked there (1994–2001). Our objective was to obtain information on all periods of the Pre-Columbian occupation, and most of our focus was on the domestic and ceremonial architecture. That material will be presented in future publications.

Our work at Dos Cabezas involved many individuals and institutions. Of great importance was the participation of Guillermo “Willy” Cock, who was co-director of the project and was largely responsible for helping secure the excavation permits from, and submitting annual reports to, the National Institute of Culture in Lima. His participation in the excavation of these tombs and his loyal support of the Dos Cabezas project were invaluable.

Alana Cordy-Collins also played a major role in the excavation. Her primary responsibility was to recover, analyze, and publish the human skeletal remains, and she is currently working on a book that will provide full documentation of that aspect of the research. All of the information in this publication regarding the age, sex, and pathology of the human skeletal remains is derived from her analyses and published articles. Alana was also involved in the delicate excavation of nearly all of the tomb contents. She has an extraordinary ability to recover fragile objects intact — an ability that constantly amazed those of us who worked with her — and was extremely helpful in the excavation of the tombs.

Four archaeologists who had recently graduated from the Universidad Nacional de Trujillo also participated in the project: Carmen Oliden, Jeisen

Navarro, Estuardo La Torre, and Hildebrando Paredes. They did excellent work, both in the field and laboratory, and were instrumental in interpreting the archaeological material.

Many men were hired to work with us on the excavation. All were from the nearby town of Jequetepeque, where I have had a home for many years. Most of them had worked with me on other projects in this region and were already well aware of excavation procedures. They are wonderful people — I have always felt privileged to work with men of this quality. Four were particularly important in the success of our work at Dos Cabezas: Desposorio Vera, Genaro Arana, Rodolfo Arana, and Henry Soto.

Walter Alva, former director of the Museo Bruning in Lambayeque, kindly made the metallurgical conservation facility of the museum available for the metal objects from the Dos Cabezas tombs. Thus we were able to store the objects in an environment with constant temperature and humidity. He also allowed us to employ Ethel Oblitas Durand, one of their metallurgical conservators, who worked full-time for more than four years cleaning and conserving these objects. Her work was excellent, as were the numerous observations that she made about the form and manufacture of the objects.

Thomas Wake made a detailed analysis of the vertebrate faunal remains from these tombs and produced an excellent report on the results of his study. I am pleased that it is included as an appendix to this book since it is the first detailed account of animal remains included in Moche burials.

Three talented artists worked closely with me to produce the line drawings in this report: Alberto Gutierrez of Lambayeque, and Jorge Gamboa of Trujillo, and Patrick Finnerty of Los Angeles. They were a pleasure to work with. I particularly appreciate their patience in working with me until we found good solutions to the various kinds of illustrations that were required. John Byron Daquioag was very helpful in creating the digital images that illustrate this volume, and Don McClelland, Marydee Donnan, and Steve Bourget not only patiently proofread several versions of the text, they also provided numerous thoughtful suggestions for improving various parts of it.

The preparation of this publication was made possible by support from the Cotsen Institute of Archaeology at UCLA, Yvonne and Harry Lenart, the Elbridge and Evelyn Stuart Foundation, the Lende Foundation, the Committee on Research of the Academic Senate at the University of

California, Los Angeles, and the Sainsbury Research Unit at the University of East Anglia.

The primary funding for our excavation at Dos Cabezas was provided by the National Geographic Society. Partial support also came from the Latin American Center at the University of California, Los Angeles, and the Lende Foundation of San Antonio, Texas.

Bill, Bob, and Elizabeth Lende became interested in my plans to excavate at Dos Cabezas even before the project began, and through the Lende Foundation they generously provided support for the first season of excavation. When I was able to obtain National Geographic support for the subsequent seasons, they continued to provide funding for the analysis, conservation, and publication of the material recovered. I am profoundly grateful to them for their generous financial support, but equally for their enthusiasm for the research, and their wonderful friendship. This book is affectionately dedicated to them.

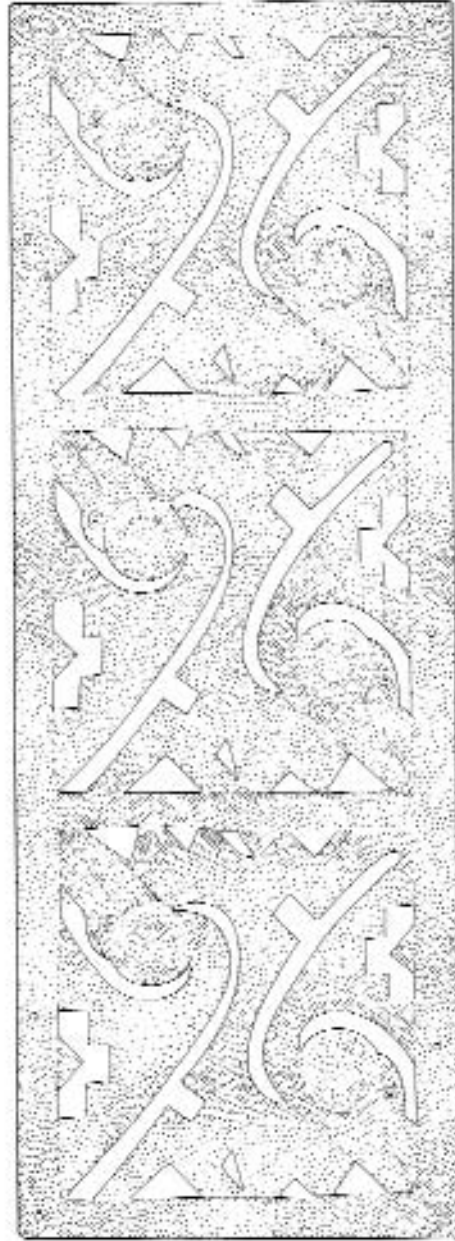

Chapter 1

INTRODUCTION

Moche civilization flourished on the north coast of Peru between approximately AD 100 and 800. Although the Moche had no writing system, they left a vivid artistic record of their beliefs and activities. Their potters created beautifully modeled and painted ceramic vessels. Their metalworkers made remarkable objects of gold, silver, and copper, skillfully creating objects in sheet metal and in lost wax castings. Their weavers produced sumptuous fabrics from cotton and wool, often elaborated with colorful woven or embroidered designs. The Moche also pyroengraved gourds, and carved and inlaid bone, wood, and stone. Tens of thousands of these objects can be seen today in museums and private collections throughout the world. Unfortunately, nearly all of them have been looted from Moche tombs by grave robbers, and thus there is no record of the grave, or the archaeological site, or even the valley from which they came. There is no record of what objects were found together in a single grave, or how those objects were placed in the burial chamber. The lack of this information severely limits what could have been learned about the Moche if the graves had been excavated archaeologically and their contents systematically recorded.

This study focuses on five Moche tombs that were archaeologically excavated at the site of Dos Cabezas. The tombs are remarkable not only for the objects they contained but also because we now know whom the objects were buried with, how the tombs were constructed, and how the tombs relate to one another both spatially and temporally. Thus they provide an unusual opportunity to understand aspects of Moche funerary practice that are lost when Moche tombs are looted, and to appreciate the extraordinary artistic and technological sophistication of this ancient Peruvian civilization.



Figure 1.1 Map of the north coast of Peru showing the area of Moche occupation.

THE MOCHE

The Moche inhabited an arid coastal plain, bordered on the east by the Andean Cordillera and on the west by the Pacific Ocean (Fig. 1.1). Most of their settlements were located in a series of valleys whose rivers flow across the coastal plain, carrying water from the mountains to the sea. Archaeologists have traced the human occupation of this area from the end of the Pleistocene, around 10,000 years ago, through the development of settled village farming communities and the subsequent rise and fall of civilizations that took place prior to the arrival of Europeans in the sixteenth century.

Centuries before Moche civilization began, the area was occupied by highly stratified societies that constructed monumental architecture and developed sophisticated weaving, ceramics, and metallurgy. The Moche took the arts, technology, and social organization they inherited from previous civilizations and developed them to form their own distinctive culture.

By channeling the rivers into a complex network of irrigation canals, the Moche greatly extended the land under cultivation, which supported abundant agriculture. They grew a wide variety of crops, including corn, beans, guava, avocados, squash, chili peppers, and peanuts. From the Pacific Ocean and from rivers, marshes, and lagoons, they harvested a rich catch of fish, shrimp, crabs, crayfish, and mollusks. Domesticated llamas, guinea pigs, and ducks were additional sources of food, along with other animals, birds, snails, and wild plants that were occasionally hunted or gathered. With an abundant and nutritious diet, the Moche sustained a dense, highly stratified population and were able to allocate large numbers of workers to the construction and maintenance of irrigation canal systems, pyramids, palaces, and temples.

The area inhabited by the Moche was not large. At its maximum it included only the valleys from Piura to Casma, a distance of approximately 550 kilometers north-south (Fig. 1.1). Its east-west extent was considerably smaller. Moche settlements are found only between the ocean shoreline and the point where the valley floodplains narrow as they enter the canyons leading up into the Andean mountain range — usually a distance of 50 to 80 kilometers. Yet the Moche maintained trade relationships with people living far beyond the borders of their territory. They obtained lapis lazuli from hundreds of kilometers to the south, in what is now Chile, and *Spondylus* shells

from hundreds of kilometers to the north, in what is now Ecuador.

The Moche probably did not have markets or money, but they almost certainly practiced the system of redistribution characteristic of Andean people at the time of European contact. Local lords received from their subjects food and commodities, which they redistributed to nobles of lesser rank. In this way, vast quantities of food, raw materials, and handmade goods were systematically collected and redistributed in an efficient manner. The surplus from redistribution supported a corps of full-time artisans who created objects for the elite. Many of these items were used by the lords to demonstrate their power and wealth; others were given by them to lesser nobility to maintain social and political allegiances and to disseminate ideology. With skilled craft specialists supported in this way, an ideal climate was created to stimulate artistic excellence and innovate sophisticated technology.



Figure 1.2 Map of the lower Jequetepeque Valley showing Dos Cabezas, the archaeological sites that are related to it, and the modern towns.

DOS CABEZAS

Dos Cabezas is a spectacular archaeological site located near the delta of the Jequetepeque River (Figs. 1.2, 1.3). Extending over an area of approximately one square kilometer, the site consists of pyramids, palaces, and domestic structures that reflect a rich and complex Pre-Columbian occupation (Donnan 2001, 2003). It is bordered by the Pacific Ocean on the west, by cultivated fields on the south and east, and by the Jequetepeque River on the north. The Jequetepeque River originates at an elevation of more than 2,800 meters in the Andean Cordillera and flows for more than 150 kilometers before finally reaching the sea at this location. Here it forms a beautiful intertidal lagoon filled with fish, waterfowl, and marsh plants. The resources from this lagoon, combined with those from the adjacent ocean, augmented the abundant food

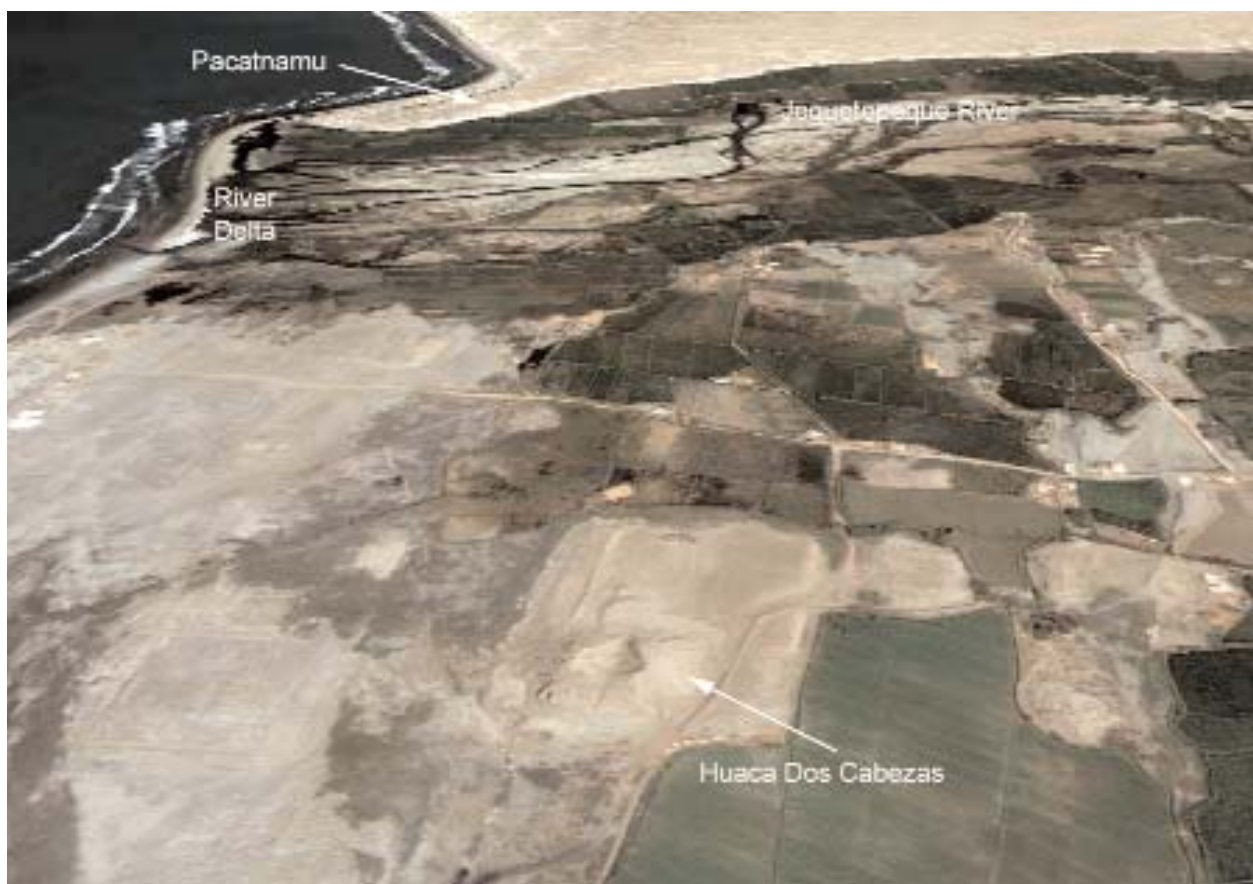

Figure 1.3 Oblique view of the lower Jequetepeque Valley, looking north.

that resulted from intensive cultivation of the rich farmland of the lower Jequetepeque Valley, thus sustaining a dense population in ancient times. Today, the area is inhabited by only a few families that work in the nearby fields and graze their cows, sheep, and goats in and around the ancient ruins.

No archaeological excavation had ever been carried out at the site of Dos Cabezas prior to 1994, when our project began, and little was known about its ancient occupation. Our excavation there over a period of eight field seasons (1994–2001) demonstrated that the site was occupied as early as the Preceramic Period, ca. 1800 BC, and may have been inhabited continuously from that time up to the beginning of the Moche occupation, approximately AD 200.

The site flourished during the Moche occupation, reaching its greatest size and population. Most of the monumental architecture was constructed at that time — Huaca Dos Cabezas (Fig. 1.4) was built, as were four smaller adobe pyramids to the east of it (designated Huacas 1, 2, 3, and 4 in Fig. 1.5), and one low platform to the west (designated Area E). A large pyramid was



Figure 1.4 The site of Dos Cabezas, looking southeast. The large structure, Huaca Dos Cabezas, is in the background, and the flat-topped structure, Huaca La Mesa, is in the center.

also built west of Huaca Dos Cabezas, consisting of thick retaining walls that encased massive amounts of loose fill (designated Area G).

The Moche occupation appears to have ended around AD 600 as a result of severe inundation by windblown sand that buried much of the site (Moseley et al. ms.). Following this abandonment, the site was unoccupied for several centuries.

Around AD 900, the northern part of the site was reoccupied by people who used Lambayeque style ceramics. They built the large, flat-topped pyramid called Huaca La Mesa, at the northern part of the site, with smaller pyramids surrounding it, and several large walled enclosures. The Lambayeque occupation ended around AD 1370. No Chimú, Chimú Inca, or Colonial



Figure 1.5 The site of Dos Cabezas showing the location of the major structures.



Figure 1.6 Moche fineware ceramic fragments from Dos Cabezas.



Figure 1.7 Moche domestic ceramic fragments from Dos Cabezas.

Period material has been found at Dos Cabezas, suggesting that the site was not occupied after the Lambayeque occupation.

Our excavations in various parts of Dos Cabezas uncovered numerous fragments of Moche ceramics (Figs. 1.6, 1.7). These included spout fragments, along with beautifully painted and polished pieces of chambers modeled in the form of animals, birds, humans, and supernatural creatures. These high-quality Moche ceramics were repeatedly found associated with common utility ware and figurines that have generally been identified as Gallinazo style — a style that is generally thought to precede Moche. It is now clear, however, that this style of domestic ware was used for centuries on the north coast of Peru, and was produced by both the Gallinazo and Moche people (Donnan 2006b, ms.b).

There were three types of Moche domestic architecture at Dos Cabezas. The simplest structures had cane walls coated with mud, and dirt floors. More elaborate architecture had adobe walls and clay floors (Fig. 1.8). The most elaborate architecture had adobe walls that were plastered with clay and often painted white, and very well-prepared clay floors. The adobes used in the domestic structures were large and cane-marked. Similar adobes were used to construct Huaca Dos Cabezas and the other pyramids and walled enclosures built by the Moche.



Figure 1.8 Excavation of Moche domestic structures at Dos Cabezas.

HUACA DOS CABEZAS

The huge structure in the southern part of the site is called Huaca Dos Cabezas (Fig. 1.9). It is the largest structure ever built in the Jequetepeque Valley and one of the largest ever constructed in South America. It consists of a rectangular platform and a pyramid on top of the platform (Figs. 1.9, 1.10). The platform is extremely large, measuring approximately 231 meters north-south by 167 meters east-west, and rising more than 6 meters above the surrounding terrain. It was constructed by building a retaining wall more than 4 meters thick along each of its four sides, and then filling the area inside these walls with loose sandy fill.

A large truncated pyramid was then constructed on the south side of the platform near its southwest corner. In contrast to the platform, the pyramid was built of solid adobe masonry. Today, this pyramid measures approximately 90 meters north-south by 90 meters east-west, and its summit is more than 30 meters above the surrounding terrain.

A massive adobe wall was also built on top of the large platform.



Figure 1.9 Huaca Dos Cabezas today, looking south.

Extending more than 100 meters along the west side of the platform, it was at least 8 meters thick and 6 meters high (Figs. 1.10, 1.11). Its south end abuts the northwest corner of the pyramid. There were probably walls on the north, east, and south sides of the platform as well, although no evidence of them has been found. The walls along the sides of the platform would have created an enormous patio more than 200 meters north-south by 150 meters east-west, with the pyramid situated near its southwest corner.

During the early Colonial Period, the central portion of the pyramid was removed during a large-scale looting operation. Nearly the entire center of the pyramid was dug out, and thousands of cubic meters of broken adobe and clay mortar were removed through a large cut near the center of its north side. This material was dumped along the pyramid's north face, completely burying much of the construction under an enormous pile of backdirt (Figs. 1.9 - 1.11). This left the summit with two humps or heads — thus the name Huaca Dos Cabezas (pyramid of two heads). Today, the entire archaeological site is known simply as Dos Cabezas.

Unfortunately, Huaca Dos Cabezas has been heavily eroded by both wind and water since its abandonment around AD 600. This erosion and the

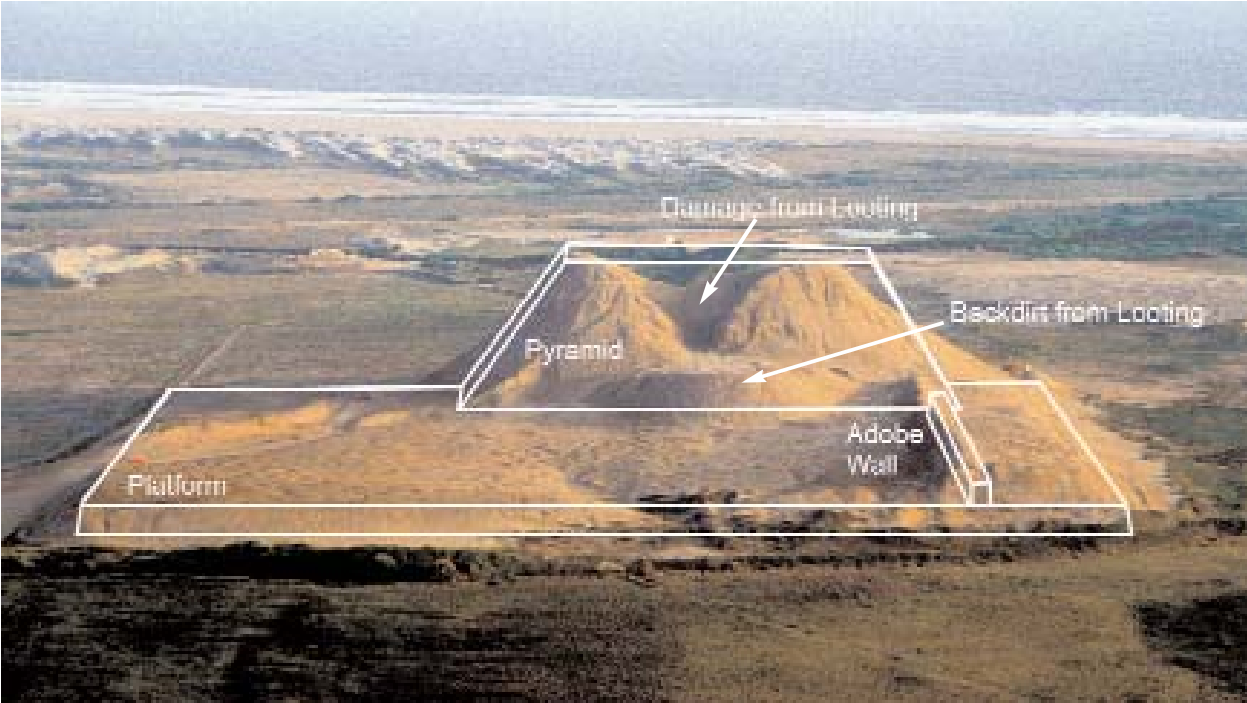

Figure 1.10 Original form of Huaca Dos Cabezas, showing damage and backdirt from looting.

damage from the massive looting operation during the early Colonial Period have together made the pyramid's original size and form extremely difficult to reconstruct. It is clear, however, that it was built in a series of construction phases, many of which tended to encapsulate the earlier stages with thick sections of solid adobe masonry. In the process the pyramid became larger, its footprint expanded, and it grew in height.

THE SOUTHWEST CORNER OF HUACA DOS CABEZAS

The massive retaining walls of the platform served to contain loose sandy fill, with rudimentary interior walls of broken adobes that served to stabilize the fill and maintain its position (Fig. 1.12). Tombs were subsequently construct-



Figure 1.11 Huaca Dos Cabezas, showing where the tombs were located.



Figure 1.12 The southwest corner of Huaca Dos Cabezas, looking northeast.

ed in the upper part of the sandy fill. As the pyramid was enlarged, it eventually expanded out over these tombs. During one of its construction phases, three additional tombs were created, not in the sandy fill of the platform but above it in the solid adobe masonry of the pyramid.

In the centuries that have passed since Huaca Dos Cabezas was abandoned, strong prevailing winds and intermittent periods of heavy rainfall have extensively eroded its southwest corner. This erosion exposed some of the tombs that were in the sandy fill of the platform, which led to the recent looting by grave robbers. These grave robbers also cut into the west face of the solid adobe pyramid, leaving an area approximately 18 meters north-south by 15 meters east-west, with scattered pits and piles of backdirt.

In an effort to learn as much as possible about the tombs that had been looted, we carefully removed the looters' backdirt (Fig. 1.13). In the process,

all pieces of ceramics, metal, bone, textile, and wood were collected. These included a great quantity and diversity of objects that had been strewn about when the tombs were looted. Most common were ceramic fragments, including pieces of Moche style fineware and domestic ware — the same types of ceramics found together in the Moche domestic architecture at Dos Cabezas (e.g., Figs. 1.6, 1.7).

Llama and human skeletal remains were also abundant. The llama remains were almost exclusively crania and lower legs — the parts most often used as offerings in Moche burials. The human bone included the remains of at least 26 adults, three adolescents, and four infants. Individuals of both sexes were represented. A few small, badly decomposed textile fragments were recovered, along with small pieces of copper and gilded copper that were



Figure 1.13 Removing the loose soil that resulted from the looting of the southwest corner of Huaca Dos Cabezas.

badly corroded and broken into tiny fragments.

While exposing the piles of looters' backdirt, we found remnants of several burial chambers. They were all oriented north-south (Figs. 1.14, 1.15), and varied between 250 and 300 centimeters in length, 170 and 200 centimeters in width, and 100 and 120 centimeters in height. Each had been made by digging a hole in the sandy fill, building a rectangular enclosure of adobe walls inside the hole, and then moving the loose fill back around the exterior of the walls. The chambers were roofed with large wood or cane beams, and then buried with more sand.

The looted tombs were all in the sandy fill of the platform and were on approximately the same level. Although we excavated into the fill below these looted tombs, we found no others below them. Therefore, all of the tombs in



Figure 1.14 Remnants of looted tombs revealed when the looted area was cleaned, looking south. Note the remains of three contiguous tomb chambers on the left.

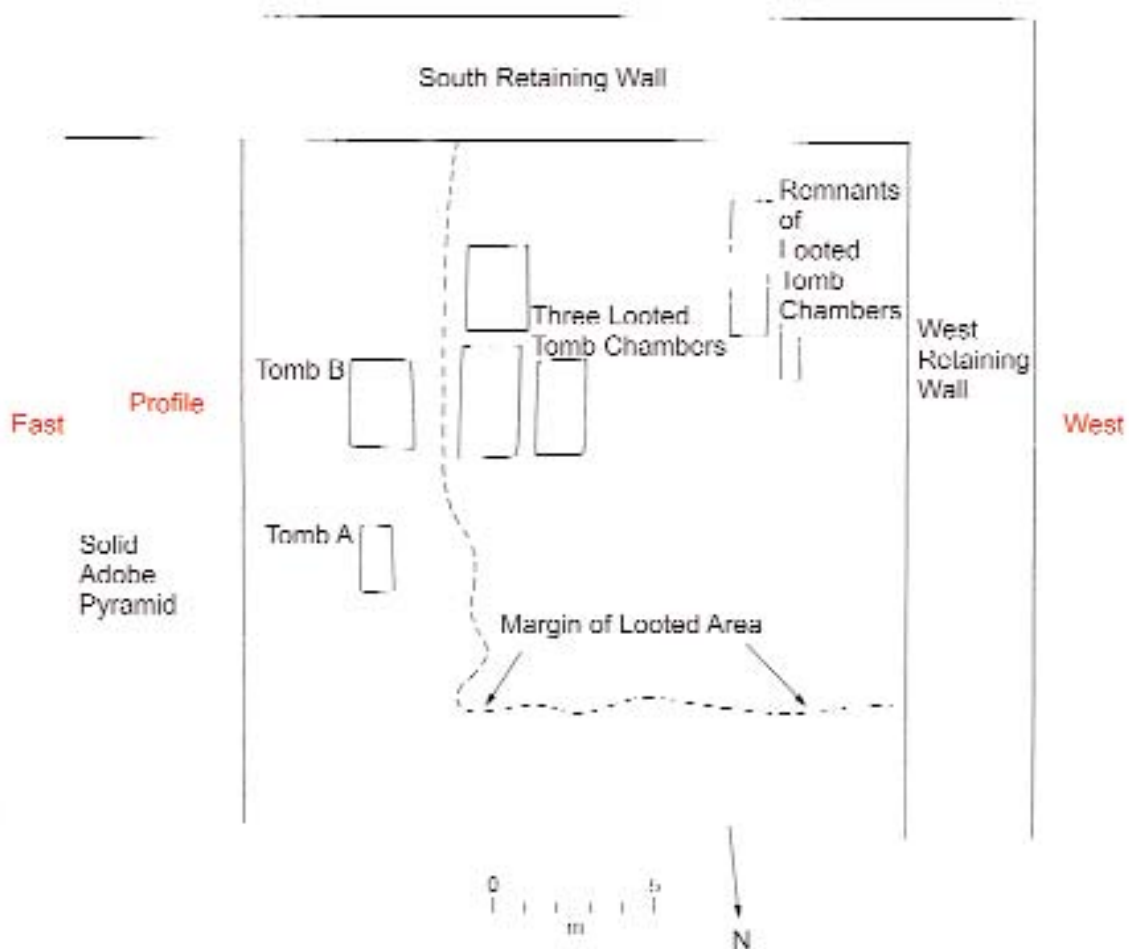

Figure 1.15 Plan of the southwest corner of Huaca Dos Cabezas showing remnants of looted tombs, as well as Tomb A and Tomb B.

the fill may well pertain to a single period in the occupation of the site.

Along the east side of the looted area we located two unlooted tombs. They were on the same level as the tombs that had been recently looted by grave robbers and were in the same sandy soil (Figs. 1.15, 1.16). They also were similar in form and construction to the remnants of the looted tombs in this area. These tombs, which are referred to as Tomb A and Tomb B, are described in the following chapters.

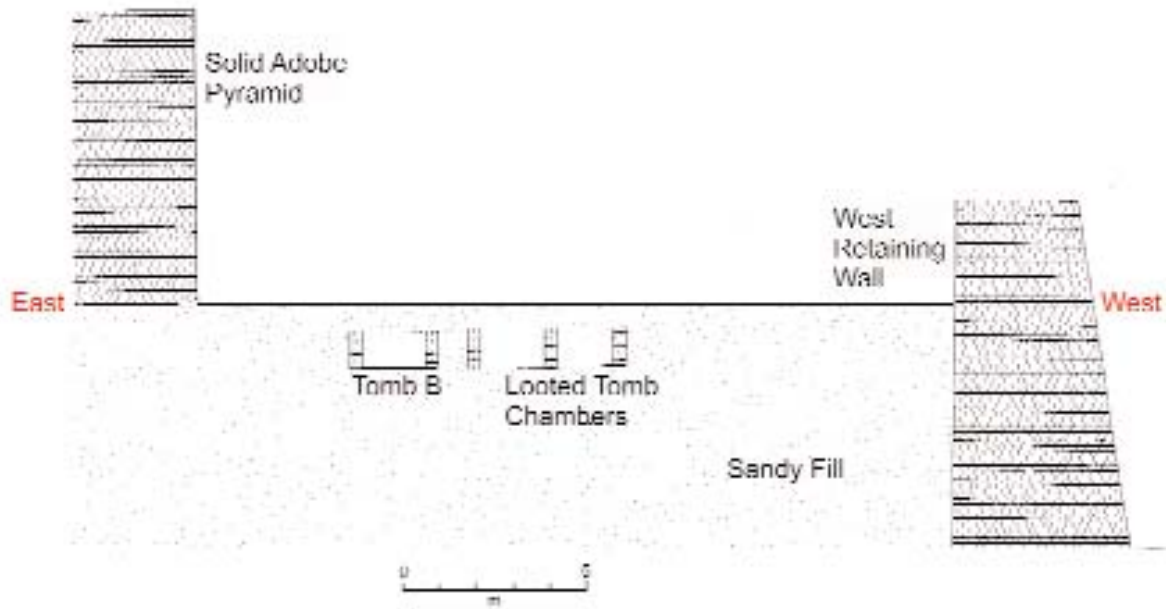

Figure 1.16 East-west profile across the southwest corner of Huaca Dos Cabezas showing the looted tomb chambers and Tomb B in the sandy fill.



Chapter 2

TOMB A

Tomb A was located near the east side of the area looted by grave robbers, together with Tomb B and the cluster of three contiguous looted tomb chambers (Figs. 1.15, 2.1). Tomb A had been dug into the loose sandy fill of the platform, and the roof was covered with approximately 60 centimeters of the same sandy soil.¹

There were numerous objects above and around the roof of the tomb (Figs. 2.2, 2.3). They were in two clusters, one at the south end of the tomb (primarily in the southeast corner) and the other at the north end of the tomb (primarily in the northeast corner). At the south end were ten ofrendas — small, crudely made vessels that are unpainted and unburnished. There were also five larger unpainted and unburnished ceramic jars (Fig. 2.3 C1–C5, Fig. 2.4) and a llama skull. In the southeast corner was a well-made jar that was painted with a white-on-red geometric design (Fig. 2.3 C17, Fig. 2.5).²

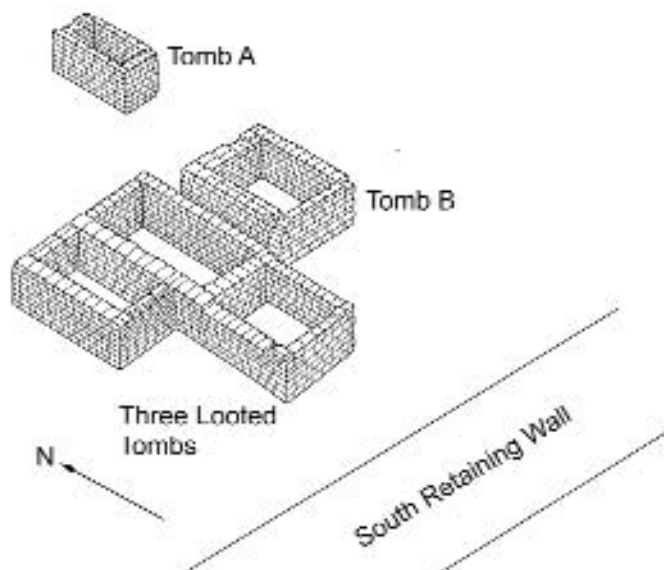

Figure 2.1 Tombs at the east side of the looted area, looking northeast.



Figure 2.2 Objects above and around the roof of Tomb A.

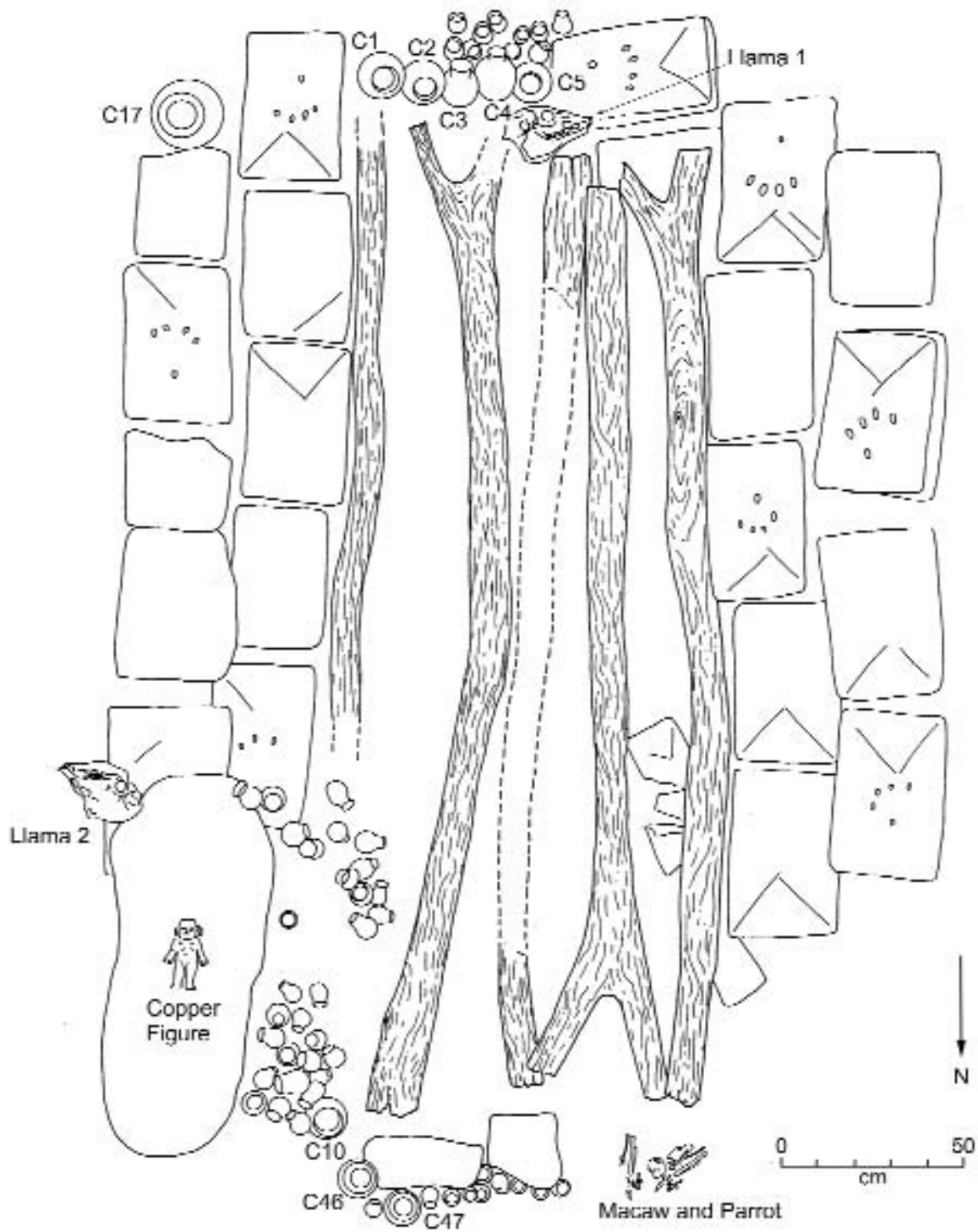

Figure 2.3 Objects above and around the roof of Tomb A.

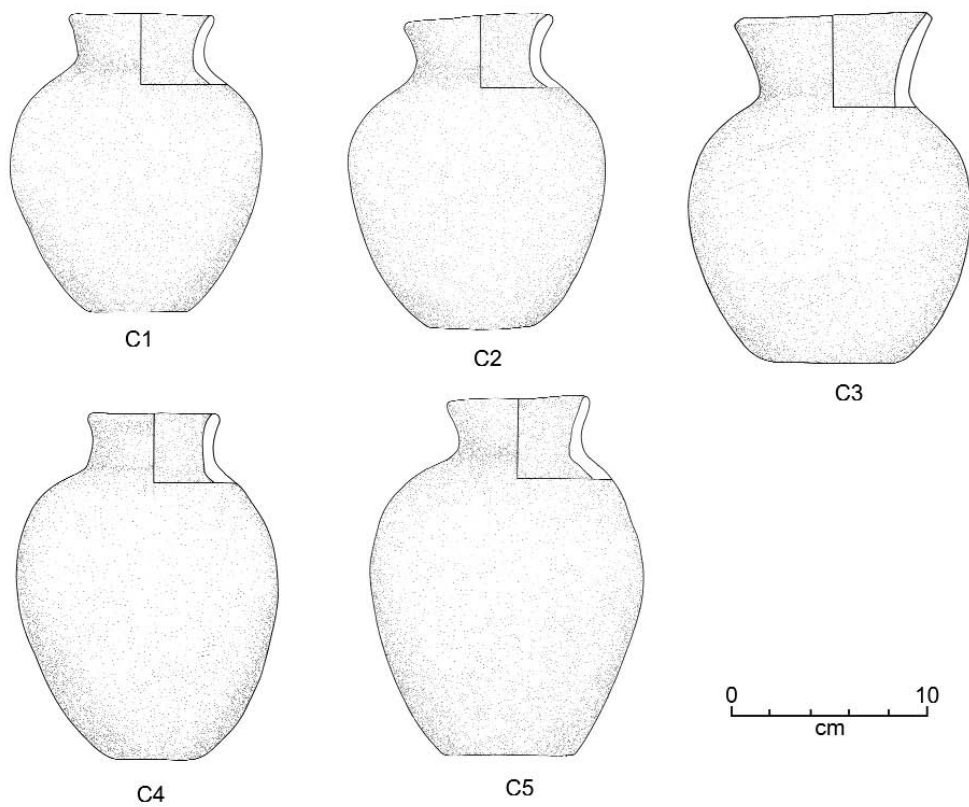

Figure 2.4 Unpainted and unburnished ceramic jars above the south end of Tomb A.

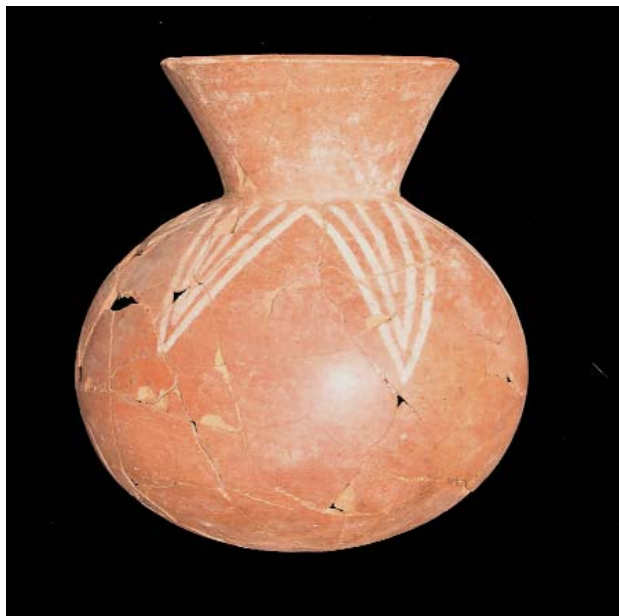

Figure 2.5 Painted jar (C17) above the southeast corner of Tomb A (height 21 cm).

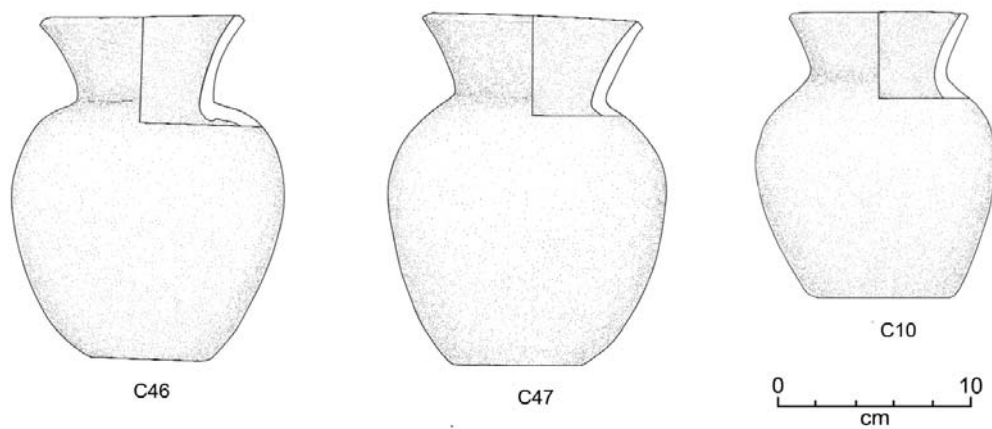

Figure 2.6 Unpainted and unburnished ceramic jars above the northeast corner of Tomb A.



Figure 2.7 Copper figure in situ.



Figure 2.8 Copper figure after cleaning and restoration (height 18.6 cm).



Figure 2.9 Roof beams over the burial chamber of Tomb A.

At the north end of the tomb were ten ofrendas, three larger unpainted and unburnished ceramic jars (Fig. 2.3 C46, C47, Fig 2.6), and a parrot skeleton. In the northeast corner were 30 ofrendas, one unpainted and unbur-

nished ceramic jar (Fig. 2.3 C10, Fig. 2.6), a llama skull, and a bundle of badly decomposed textiles containing a small copper figure lying on his back with his head to the south. The copper figure was badly broken from the weight of the soil above it (Fig. 2.7), but it was possible to reconstruct it (Fig. 2.8).

The roof of the tomb was supported by five algarobo beams that extended north-south over the burial chamber (Fig. 2.9). Three of these were Y-shaped posts of the type frequently shown in Moche architecture (Fig. 2.10). Remains of caña brava (*Gynerium sagittatum*), marsh grass (*Phragmites communis*), and cattail (*Typha angustifolia*) were found on top of the roof beams, apparently the remains of roofing material. Because these materials were extremely decomposed, it was not clear how or in what sequence they had been used. Nevertheless, the roof clearly had been substantial and was meant to create an open burial chamber.

The burial chamber was small. Its interior measured approximately 215 centimeters north-south, 105 centimeters east-west, and 110 centimeters deep (Fig. 2.11). All four walls of the chamber were made of adobes laid in fairly even courses. Because the adobes were not set with mortar, however, the pressure of the soft fill on the outside of the tomb caused portions of the walls to move into the tomb chamber. The movement was most pronounced on the long walls – those on the east and west – and less on the shorter north and south walls. The chamber had no prepared floor but consisted simply of the loose sandy soil similar to the fill of the platform.

The inside of the burial chamber had originally been an open space, presumably containing the body of one or more individuals and some associated objects. As the roofing material decomposed, loose sandy soil fell in and completely filled the chamber. Before that occurred, however, the burial chamber was reentered through an opening that was made at the northwest corner. This must have occurred when the roof was still in good condition and was supporting the material above it.

Parts of the body of an individual were found near the floor of the burial chamber (Fig. 2.11). This may have been the individual who had originally been buried in the tomb. If so, it appears that his body was removed,



Figure 2.10 Moche fineline painting of a structure with Y-shaped posts.

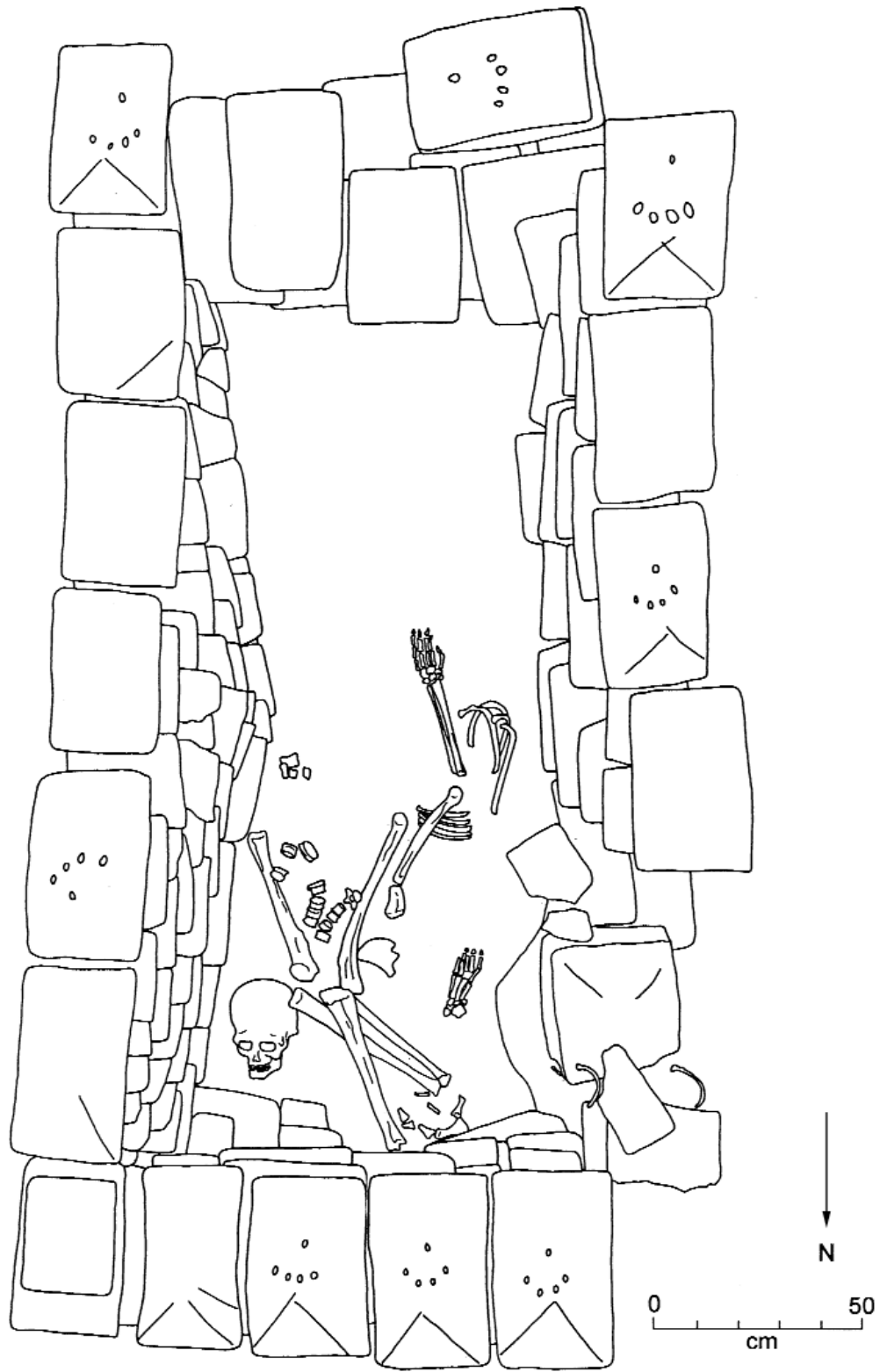

Figure 2.11 Inside the burial chamber of Tomb A.

along with any associated objects, and sometime later returned to the burial chamber.

Before the body was returned, grayish white sand was carefully smoothed over the bottom of the burial chamber. This sand was then covered with a textile that subsequently decomposed to a red powder. Portions of this textile extended up over the lower adobes at the northwest corner where the burial chamber had been opened.

Assuming that the body parts were those of the individual originally buried in the tomb, considerable time must have elapsed between when the body was originally buried and when it was removed and subsequently returned. The corpse had become so dry that it broke into sections when it was moved; the legs, arms, and head separated from the torso, and portions of the limbs broke apart. Nevertheless, enough soft tissue was still preserved to maintain the articulation of many of the bones. Since none of the bones had cut marks, the dismemberment must have resulted entirely from the movement of the body after it had desiccated.

The body was returned in pieces to the burial chamber. The skull appears to have been returned first. It was placed upright in the northeast corner of the burial chamber. The other parts of the body appear to have been returned in no particular order. The right radius was the only missing bone — presumably misplaced in the process of returning the corpse to the burial chamber. A few ribs were found where the burial chamber had been opened at the northwest corner. It is likely that there were ceramics and other objects originally inside the burial chamber. If so, they must have been removed along with the individual's body, but not returned.

Analysis of the skeleton of this individual indicates that he was an adult male, approximately 18–20 years of age at the time of his death. However, he was considerably taller than most Moche males. He would have been 175 centimeters in height, while the majority of Moche males ranged between 147 and 167 centimeters (Verano 1997).

The reentry of this burial chamber, removal of its contents, and replacement of the body must have been done by the Moche people who were occupying the site at that time. It is unlikely that the tomb reentry was done clandestinely. None of the objects on the roof appears to have been disturbed, even though it probably would have been easier to enter the burial chamber

from above, and at the same time remove the painted jar (Fig. 2.5) and the copper figure (Fig. 2.8). It is more likely that the reentry was sanctioned and that the replacement of the body, on top of a textile and carefully smoothed sand, followed known ritual procedures. The excavation of Tomb B, which is discussed in the next chapter, provides additional evidence for the ritual nature of tomb reentry.

NOTES

¹ The original field number of this tomb is A53T2.

² This jar is very similar in form and decoration to a jar found in Tomb 1 (Fig. 7.5).

Chapter 3

TOMB B

Tomb B was located near the east side of the area that had been looted by grave robbers (Fig. 1.15).¹ It was east of three contiguous tomb chambers that they looted, and approximately 2.30 meters north of Tomb A (Fig. 3.1). All of these tomb chambers were constructed of adobes, in holes that had been dug into the loose sandy soil that was used as fill to create the platform (see Chapter 1). Their roofs were all at about the same level.

There was approximately 1.40 meters of sandy fill above the roof of the Tomb B. In that fill, approximately 1 meter above the roof, there was a young male (Burial 1), approximately 15–18 years of age, lying on his right side with his left leg flexed and his head to the south (Fig. 3.2). There were no artifacts associated with him.

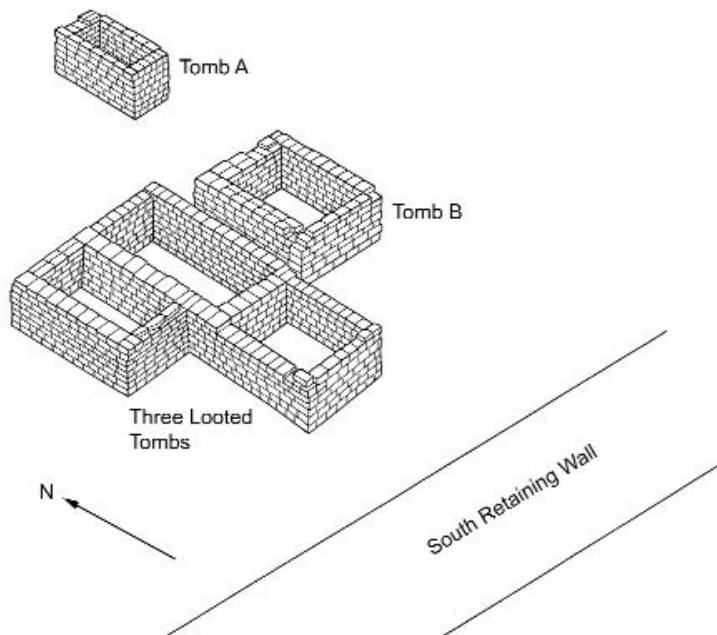

Figure 3.1 Tombs at the east side of the looted area, looking northeast.

Approximately 1 meter southwest of this burial were the remains of an offering consisting of burned textiles and fragments of ceramics that had been broken over a large stone (Fig. 3.3). The stone had been placed in the soft sand and some liquid had been poured around it, leaving a thin lamina of fine soil. A fire was then made over and around the stone and elaborate textiles were burned, leaving only ash remnants. At least four ceramic vessels were subsequently broken on the stone and their pieces scattered on top of the burned textiles. Many fragments from the broken ceramic vessels were missing, but since the offering was on the margin of the area disturbed by the grave robbers, it is possible that all of the fragments had originally been left in place, and some were later removed by the looters. The fragments recovered were from a stirrup spout bottle portraying a seated figure (Fig. 3.4), a plain jar whose form could not be reconstructed, and a matched pair of large jars portraying figures chewing coca. One of the latter was complete enough to be reconstructed (Fig. 3.5). There were also several small ofrendas.



Figure 3.2 Burial 1, partially exposed, in the fill above Tomb B.



Figure 3.3 Remains of the offering above Tomb B.



Figure 3.4 Fragments of a ceramic vessel from the offering above Tomb B.

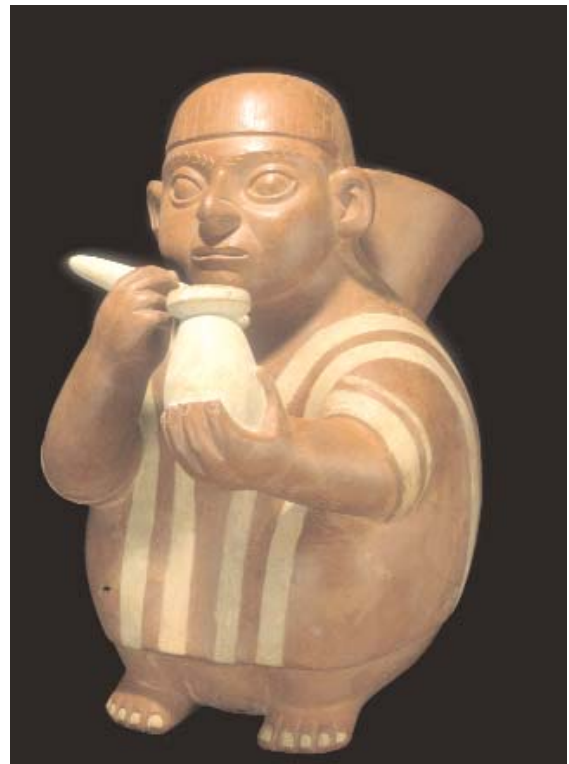

Figure 3.5 One of two ceramic jars depicting a coca chewer, after reconstruction (height 34.7 cm). From the offering above Tomb B.

At the level of the roof beams along the east side of the tomb were two adult males. They were lying on their backs in a fully extended position, with their heads to the south (Figs. 3.6, 3.7). The one furthest to the east (Burial 2) was approximately 20 years of age, while the other (Burial 3) was approx-



Figure 3.6 The material above the roof beams of Tomb B. One individual, Burial 2, is still in the side wall on the left.

imately 40 years of age. There were no artifacts associated with either of these individuals.

Along the south side of the tomb was a female (Burial 4), approximately 50 years of age, lying extended with her head to the east. Analysis of the

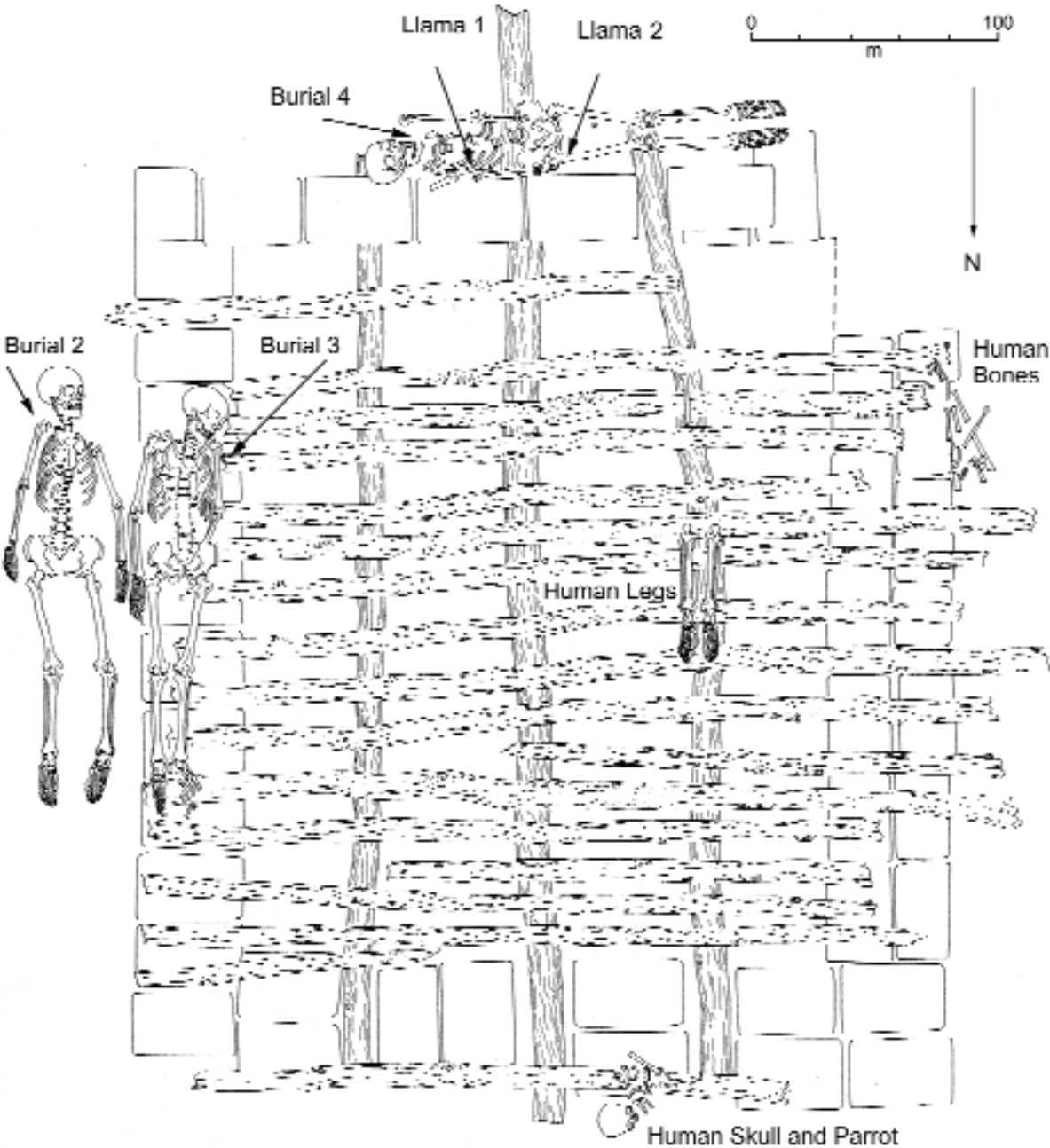

Figure 3.7 Plan of the material above the roof beams of Tomb B.



Figure 3.8 An oblique view, looking east, of the material above the roof beams of Tomb B. Burial 4 is on the far right.

position of her bones indicated that her body was almost certainly curated for some time before she was buried adjacent to this tomb. Much of her soft tissue had decomposed, allowing the bones in her torso to fall out of position (Fig. 3.9). Associated with the woman were seven spindle whorls (Fig. 3.10) and two llama skulls — one beneath her torso and the other beneath her right thigh.

Two human lower legs with their feet were found above the center of the roof (Fig. 3.11), and other human bones were found near its southwest corner (Fig. 3.12). Above the north end of the roof were more bones, including the skull of a man about 40 years of age, and parts of a parrot (Fig. 3.13).

The roof was made with large beams extending both north-south and east-west (Fig. 3.7). Some decomposed organic material was found above and between the roof beams. It appears to have been cane that formed part of the



Figure 3.9 Burial 4 showing displacement of bones in the torso.

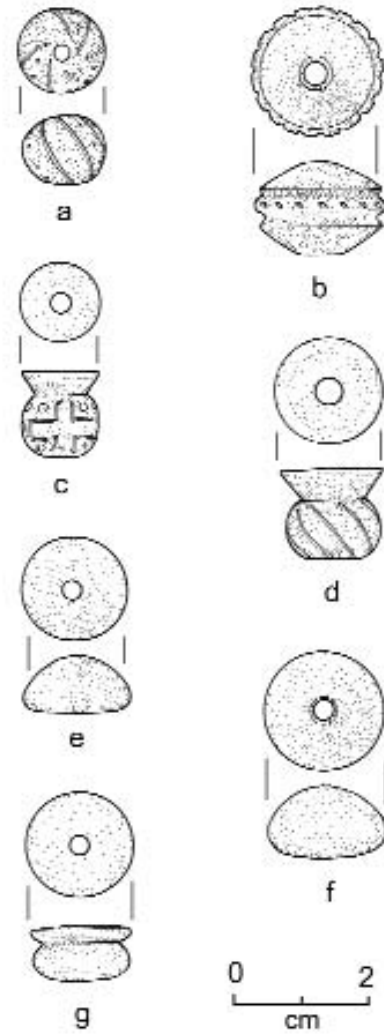

Figure 3.10 Spindle whorls associated with Burial 4.



Figure 3.11 Human lower legs on the roof of Tomb B.



Figure 3.12 Human bones on the roof of Tomb B.



Figure 3.13 Parrot on the roof of Tomb B.

roof. These materials were extremely decomposed, however, and it was not clear how they had been used. Nevertheless, the roof was clearly substantial and was meant to create an open burial chamber.

The burial chamber was considerably larger than that of Tomb A. Its interior measured approximately 295 centimeters north-south by 205 centimeters east-west, and 110 centimeters deep. The upper portion of the chamber was filled with chunks of broken adobes and loose fill, along with a few

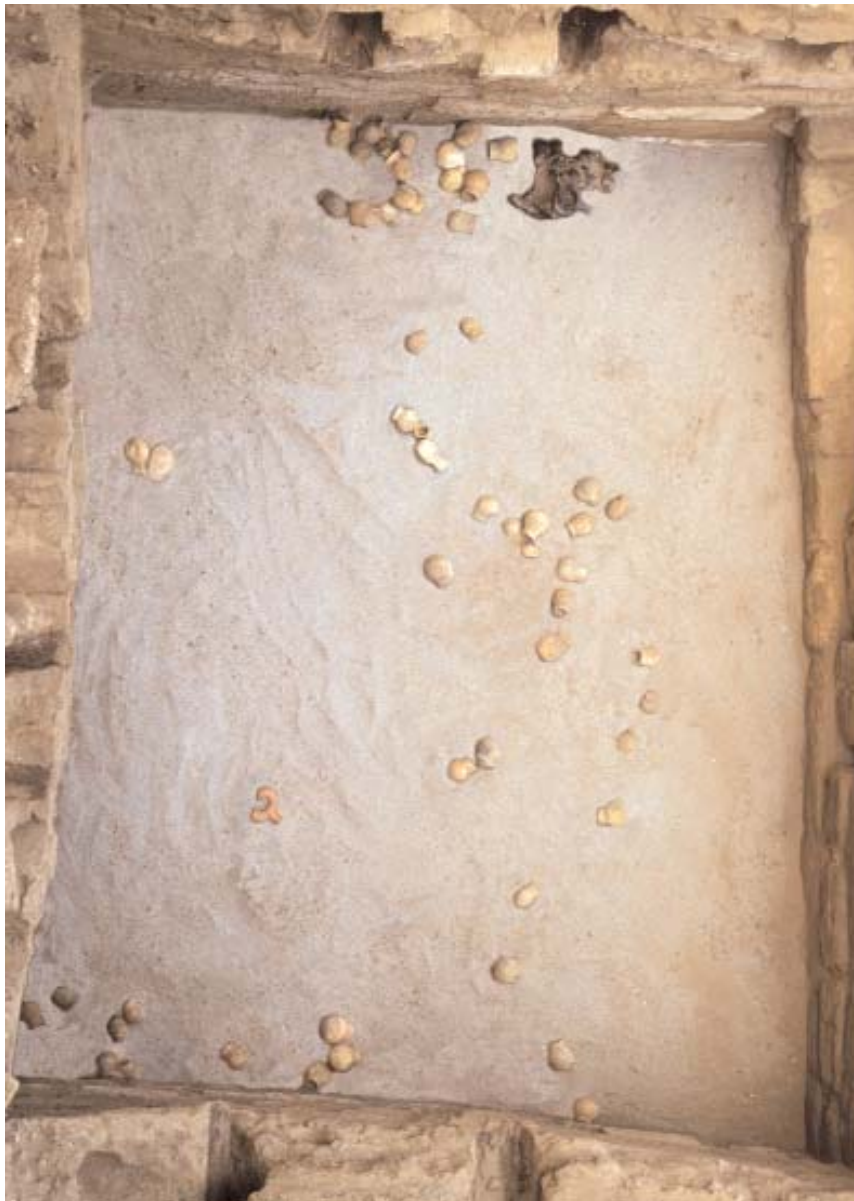

Figure 3.14 The floor of Tomb B with its associated artifacts.

human bones, two fragments of copper, and two shell beads. This material appears to have fallen in as the roof decomposed and collapsed.

On the floor of the burial chamber (Figs. 3.14, 3.15) were 70 ofrendas, one stirrup spout that had broken off a bottle that was missing (Fig. 3.15 C1), and most of another stirrup spout bottle in the form of a reclining feline (Fig. 3.15 C2, Fig. 3.16). These ceramics were resting on traces of what appeared to be a textile that had decomposed, leaving a red and a white residue.

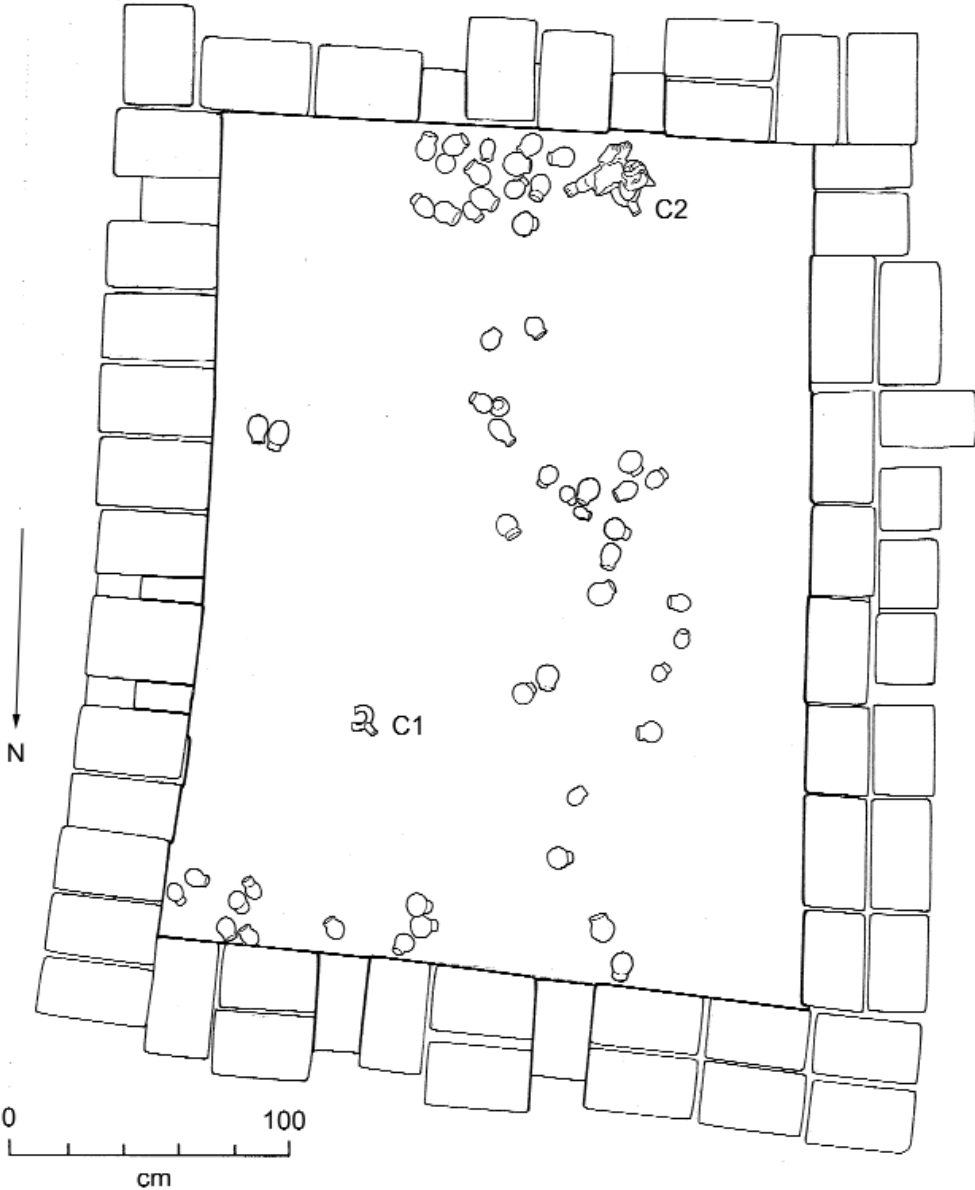

Figure 3.15 Plan of the floor of Tomb B.



Figure 3.16 *Reclining feline C2 (height 17.4 cm).*

Beneath this residue was a layer (approximately 2 centimeters thick) of clean, grayish white sand that had been carefully smoothed and leveled. Beneath the sand was the floor of the tomb, which consisted of small chunks of clay.

The tomb did not contain either a skeleton or any additional artifacts, suggesting that it, like Tomb A, had been reentered sometime after the burial was completed. There was a hole in the southwest corner of the tomb wall that would have allowed access to the burial chamber. As with Tomb A, this could not have been made in recent years by grave robbers; it must have occurred when the roof was still intact and able to support the material above it. Otherwise, tunneling into the burial chamber after the roof had collapsed would have been nearly impossible and would have disturbed the burials and offerings that were on top of the roof.

Tombs A and B were clearly of the same type and the same time period as the tombs that had been looted by grave robbers. Their form, construction, and orientation were the same, and they were on approximately the same level within the sandy fill of the platform. It is not possible to determine when Tombs A and B were reentered, although various factors suggest that their

reentries may have occurred at about the same time: they are adjacent to one another, both were entered through a corner on the west side of their burial chambers, both had a thin layer of grayish white sand carefully smoothed over the floor, and both apparently had a textile placed on this sand, with objects placed above the textile.

Sometime after Tombs A and B were reentered, the Moche built over them in a series of construction stages. This clearly demonstrates that the reentry occurred during the Moche occupation of Dos Cabezas, while the ceremonial architecture was still being modified.

The construction that covered Tombs A and B occurred along the west face of the pyramid and consisted of solid adobe masonry. During the expansion, three tombs were built into the new adobe masonry. They are clearly later in time than Tombs A and B and will be referred to as Tombs 1, 2, and 3 in the chapters that follow.

NOTE

¹ The original field number of Tomb B is A50T1.

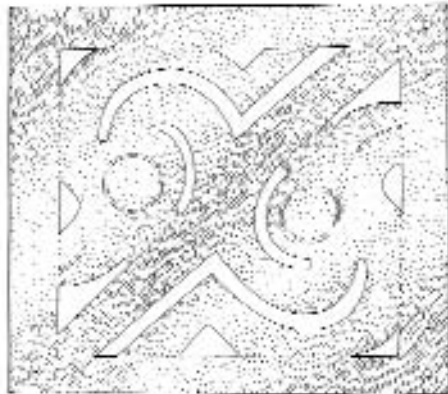
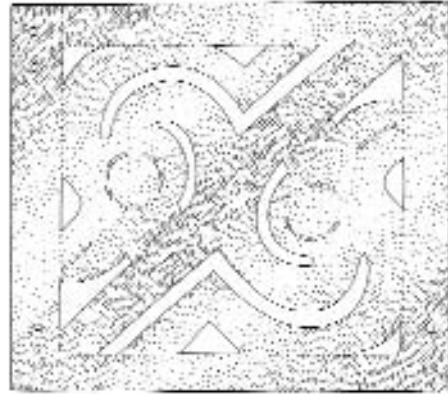

Chapter 4

ARCHITECTURAL MODIFICATIONS

Before describing the tombs found in the solid masonry construction, it is important to understand the sequence of construction at the southwest corner of the pyramid after Tombs A and B were reentered in Moche times. This will make it possible to understand how Tombs 1, 2, and 3 were subsequently constructed in the solid masonry above, and how they relate to Tombs A and B in the sand fill below.

Although we attempted to identify, in as much detail as possible, the successive construction stages at the southwest corner of the pyramid, our efforts were limited by four factors:

1) The extensive erosion that has occurred at this corner of the pyramid due to the prevailing winds from the southwest, combined with periods of rainfall that have eroded much of the pyramid's outer surface.

2) The extensive looting in this area which demolished large portions of the solid masonry construction.

3) The limited scope of our excavation. Every effort was made to dismantle as little of the architecture as possible. Therefore, nothing was excavated unless there was compelling reason to believe that it would reveal important information about the burial patterns or architectural sequence. Some rooms, walls, and floors extended beyond the limits of our excavation, but to expose them completely would have required dismantling extensive portions of the pyramid. This was not warranted, and thus the complete size of many of the rooms, walls, and floors could not be determined.

4) The lack of absolute dates for the successive stages of construction. Although we were able to identify the sequence of construction, we could not determine how much time elapsed between stages, and in some cases whether two

portions of the architecture were remodeled at the same time or one part was completed before the other began.

In spite of these limitations, we were able to identify 13 sequential construction stages, based on evidence of successive remodeling and reuse of the architecture. The first nine stages are discussed in this chapter in order to demonstrate the changing use of the pyramid's southwest corner and the chronology of the burials that we found there.

STAGE 1

As discussed in Chapter 1, the first stage was the construction of a large rectangular platform. Massive retaining walls approximately 4 meters thick and at least



Figure 4.1 Excavation of the architectural modifications at the southwest corner of the Dos Cabezas pyramid. View looking east.

7 meters high formed its sides. The area within these retaining walls was filled with loose sandy material.

STAGE 2

In Stage 2, the platform was used as a cemetery. Holes were dug into the loose fill and lined with adobes to create rectangular burial chambers, which were roofed with cane or algarrobo beams. These tombs, which were all on approximately the same level, included Tombs A and B, as well as the burial chambers in the sandy fill that had been recently looted by grave robbers (Figs. 1.15, 1.16, 4.2, 4.3).

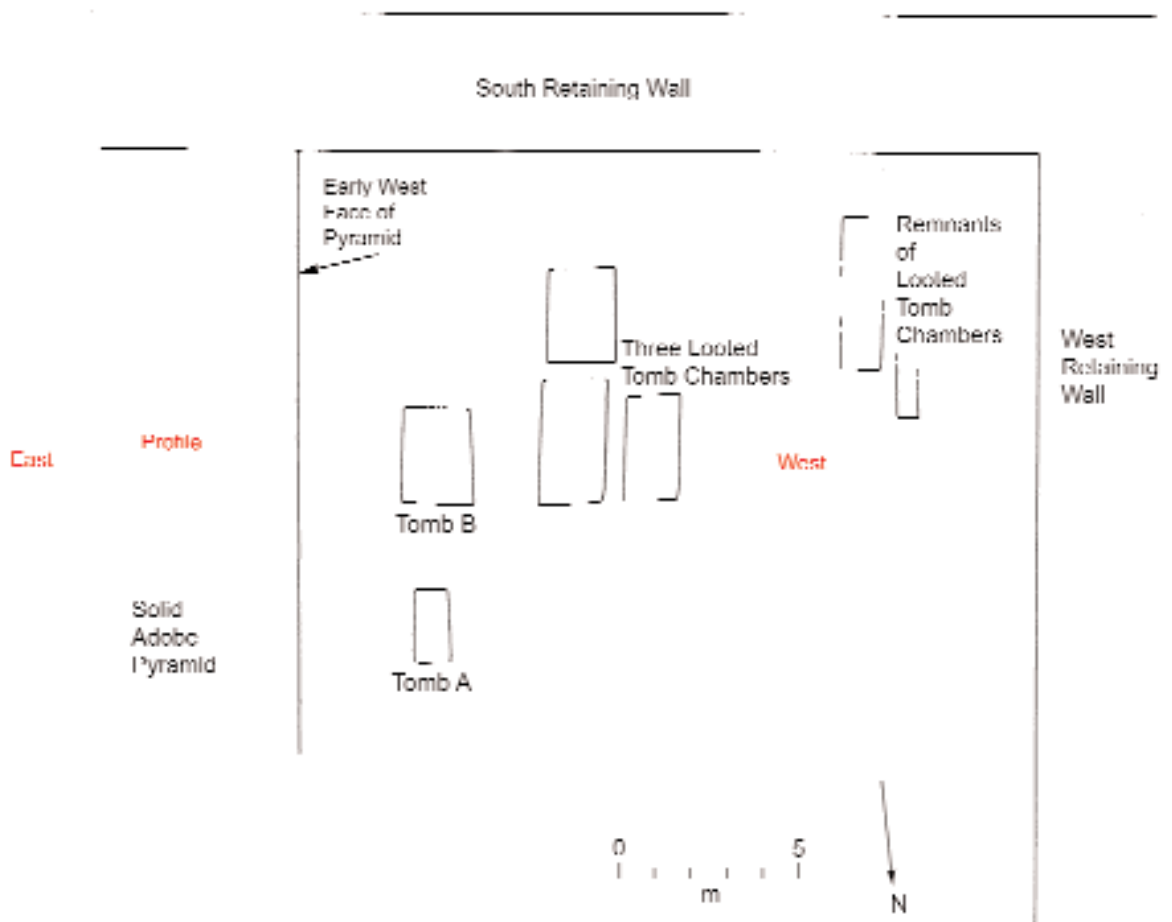

Figure 4.2 STAGE 2: Plan of the southwest corner of the platform showing the retaining walls, the solid adobe pyramid, and the tombs that had been built into the sandy fill.

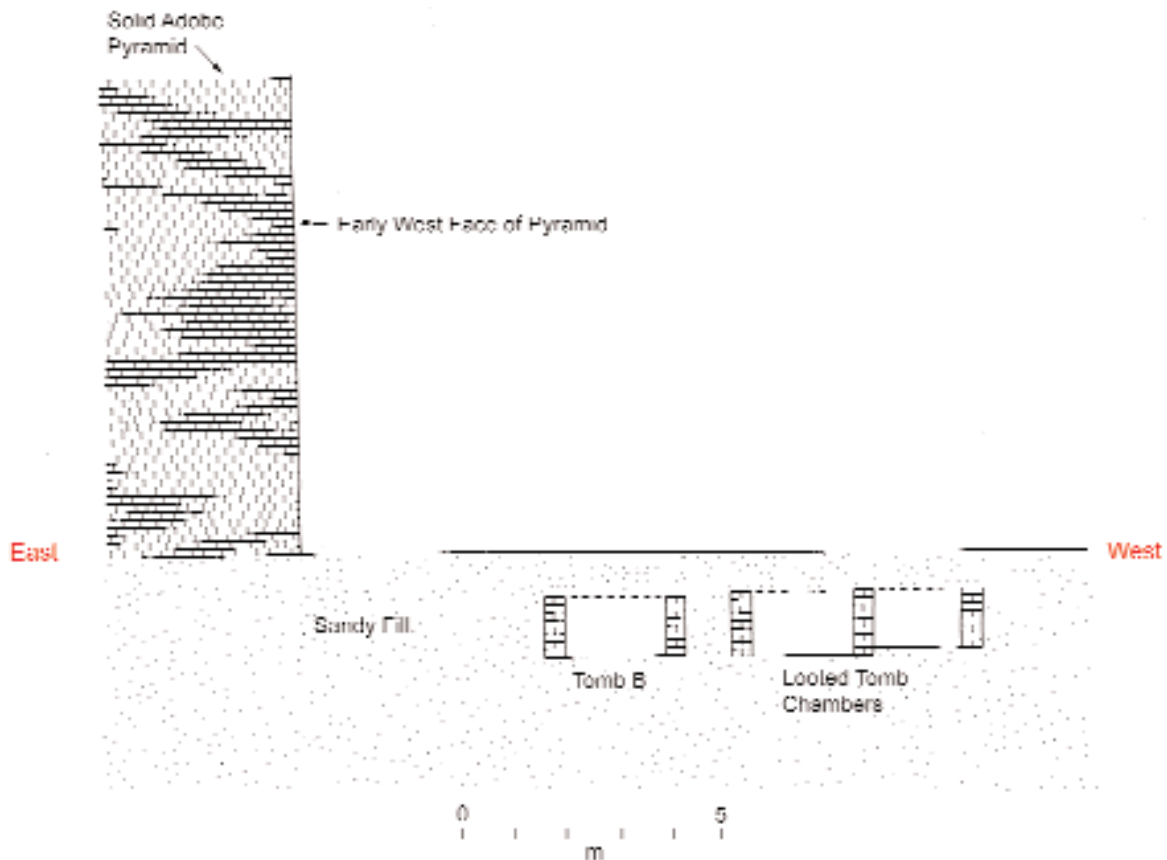

Figure 4.3 STAGE 2: East-west profile as indicated in Fig. 4.2, showing the tomb chambers in the sandy fill of the platform.

STAGE 3

After the tombs in the platform's sandy fill had been constructed and both Tombs A and B had been reentered, radical changes took place at the southwest corner of Huaca Dos Cabezas. In Stage 3, a large room was built against the west side of the solid adobe pyramid, covering both Tombs A and B (Figs. 4.4, 4.5). The room had two large walls aligned in a north-south orientation. The wall on the east abutted the pyramid, while the one on the west was free standing. The two walls were very well built, smoothly plastered, and painted white. The floor was divided into rectangular bins, each measuring approximately 90 centimeters by 90 centimeters, with a depth of approximately 46 centimeters. The walls that formed these bins were approximately 20 centimeters thick, and were also smoothly plastered and painted white on all sur-

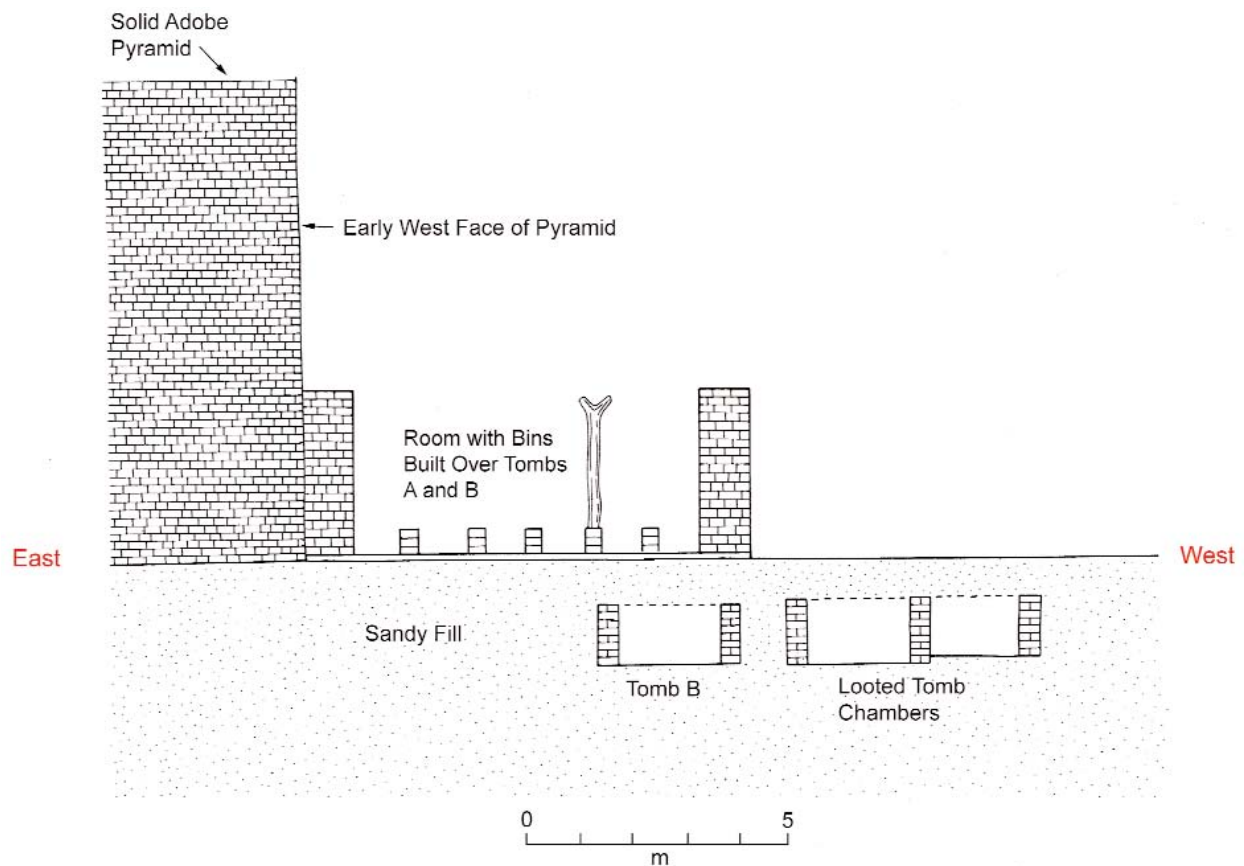

Figure 4.4 STAGE 3: East-west profile as indicated in Fig. 4.2, showing the room with bins that was built over tomb chambers in the sandy fill of the platform.

faces. White paint covered the floors of the bins as well. The bins were empty and exhibited no sign of significant wear or use.

The room had a north-south row of postholes, suggesting that it once had a roof partially supported by Y-shaped posts (Figs. 4.4, 4.5). The posts were located at the intersecting walls of the bins and were evenly spaced, approximately 2 meters apart. The row of posts was not located along the center of the room, with an equal number of bins on each side of the posts. Instead, there were two rows of bins west of the posts and four rows east of them.¹ The entrance to this room was probably at its north or south end, but the south end had been destroyed by grave robbers and the north end was beyond the limit of our excavation.

It may be that the entire southwest corner of the sand-filled platform was covered over at this time with a floor and/or additional buildings.

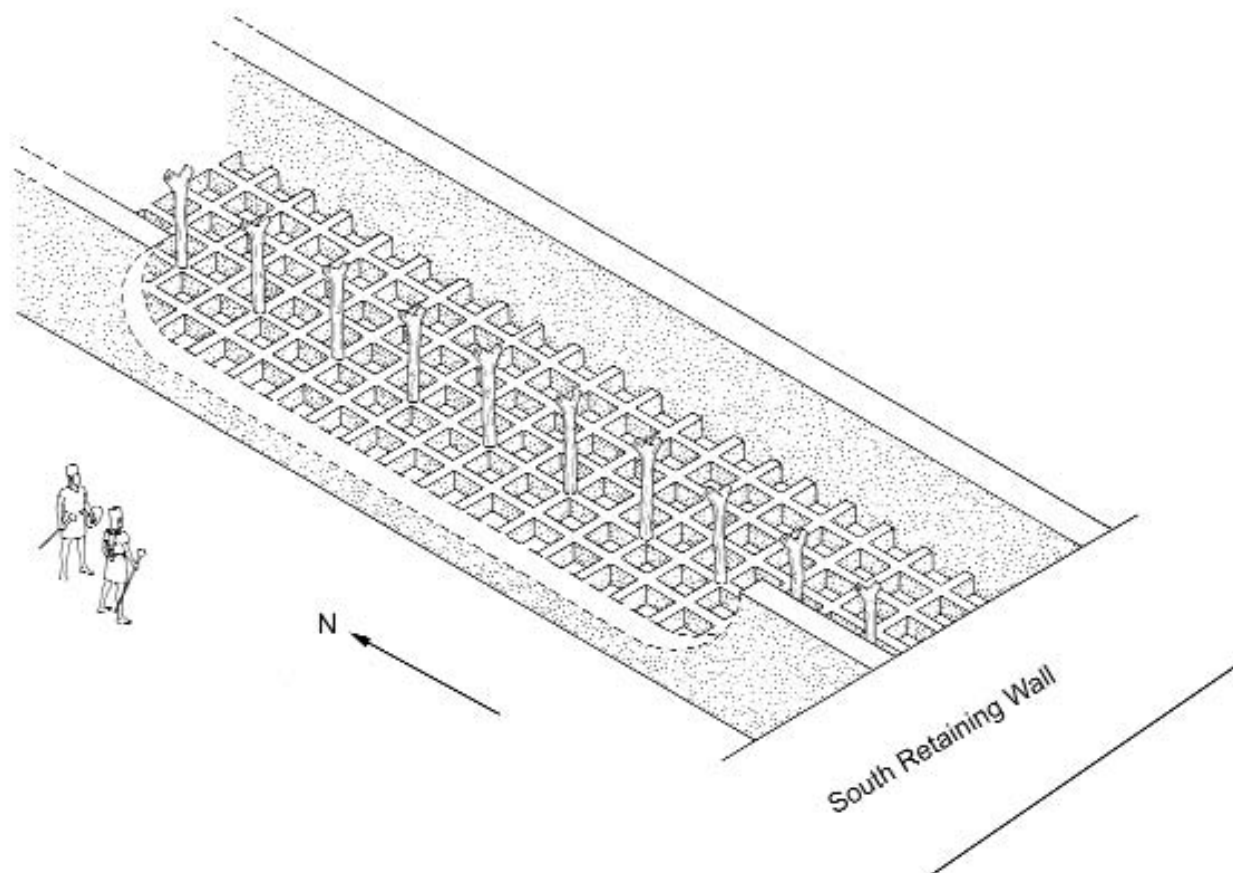

Figure 4.5 STAGE 3: A room with white bins was constructed over the sandy fill of the platform, covering Tombs A and B.

Alternatively, the western part of it could have remained as an open cemetery area while only the eastern part was covered with new construction. Unfortunately, the extensive looting in this area destroyed all evidence that would resolve this issue.

It is possible that the white bins in the room were for storage. An area of high-status domestic architecture at the Pyramids at Moche had two small rooms, each divided into four bins by low walls (Pozorski and Pozorski, 2003). The floors and walls of those bins were plastered but not painted; it is assumed that they were for storage. If the large room with white bins at Dos Cabezas was for storage, it may have been to store prestigious commodities — perhaps serving for the massive accumulation of wealth that was warehoused by the ruling elite.

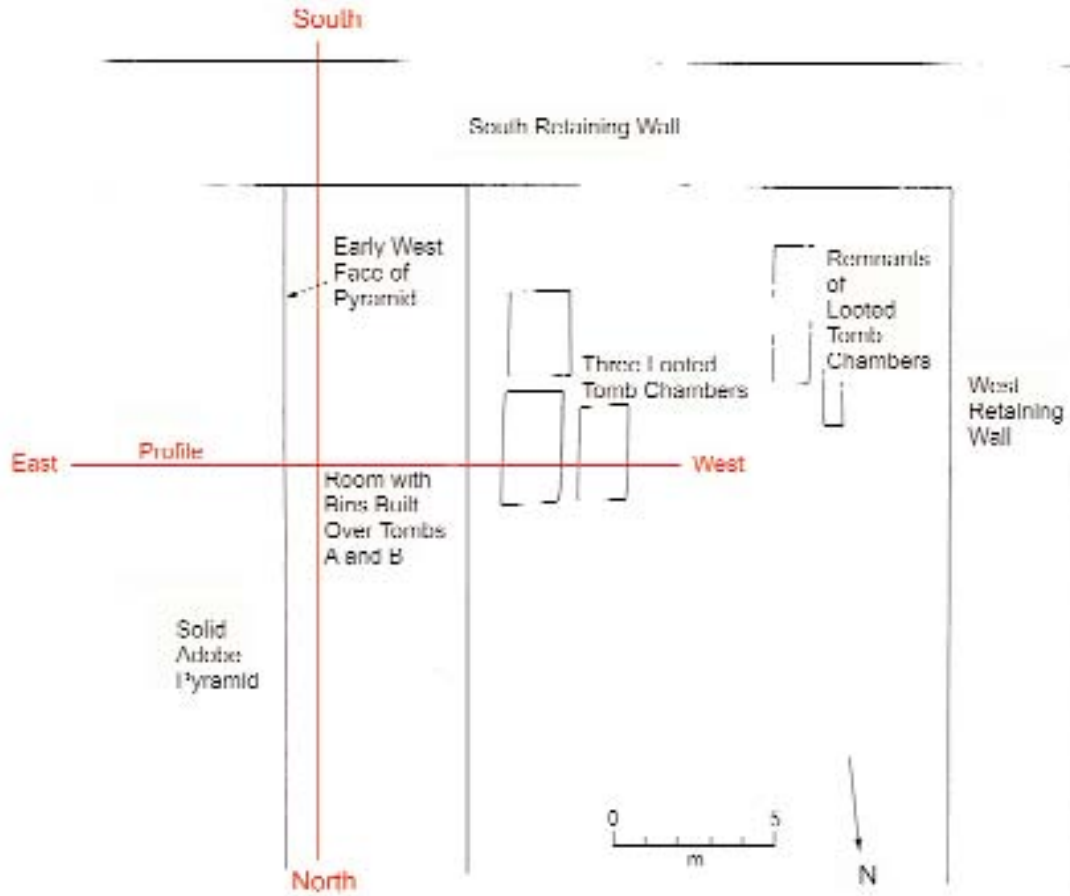

Figure 4.6 STAGE 3: Plan of the southwest corner of the platform showing the retaining walls, the solid adobe pyramid, and the room with bins that was built over Tombs A and B.



Figure 4.7 Remnants of the bins on the floor of the room constructed during Stage 3.

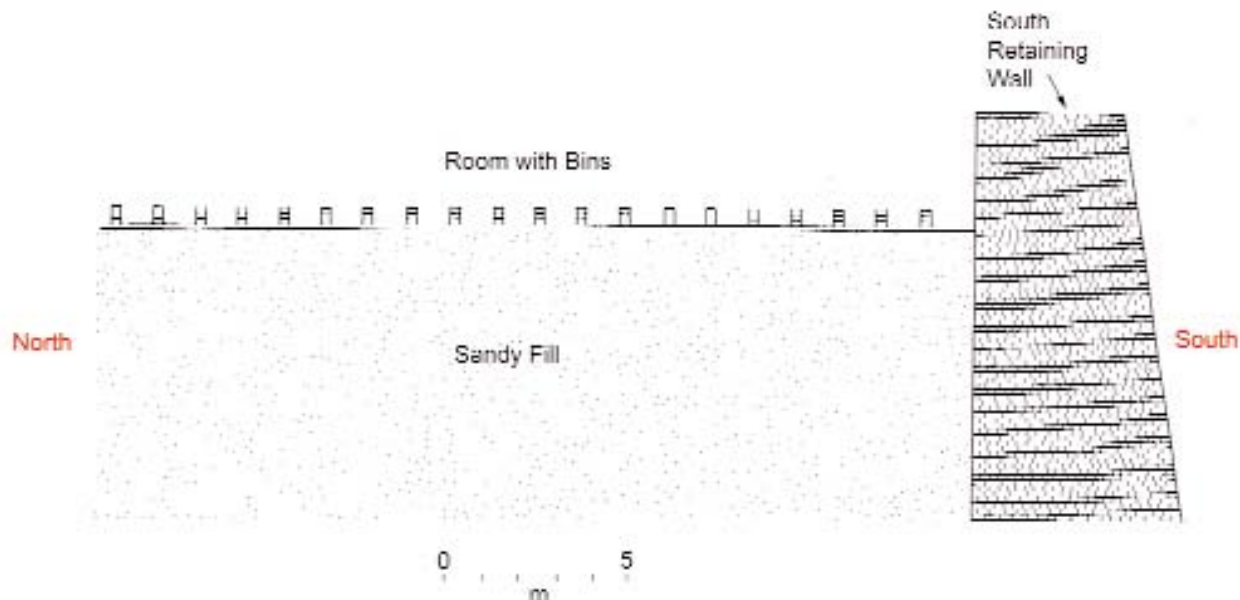

Figure 4.8 STAGE 3: North-south profile as indicated in Fig. 4.6, showing the room with bins that was built over the sandy fill of the platform.

STAGE 4

Sometime after the large room with white bins was constructed, there was another major period of building. The solid masonry construction of the pyramid was expanded further west, completely covering the northern portion of the room with bins (Fig. 4.9). A thick (approximately 90 centimeters) east-west wall was built, dividing what remained of the large room into a small North Room and a larger South Room (Fig. 4.10). To build this wall, the bins where the wall was to be located were demolished to floor level, the wall was constructed, and the bins abutting it on both sides were repaired. The repaired bins, as well as the sides of the new wall, were smoothly plastered and painted white. The original north-south row of posts was maintained, and one of the posts was encapsulated by the thick east-west wall that divided the North Room from the South Room.

The east side of the North Room was reduced by the construction of a large solid bulk to support a high walkway along the west face of the pyramid (Fig. 4.9). This walkway turned east into the pyramid, presumably giving access to an interior room.

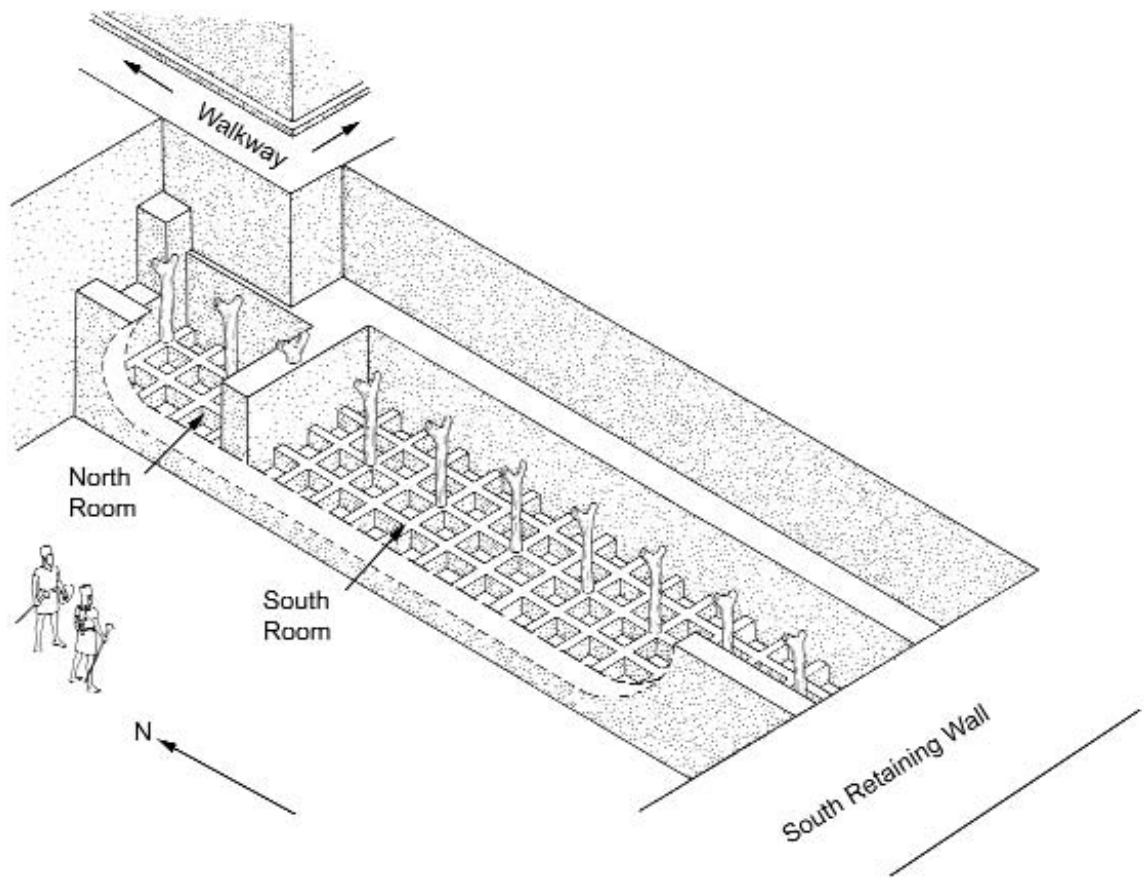

Figure 4.9 STAGE 4: The room with bins was reduced in width and divided into the North Room and South Room.



Figure 4.10 View looking northeast showing the remnant of the wall between the North Room and the South Room.

A solid bulk of adobes was constructed along the east wall of the South Room, thus reducing its width from approximately 6 meters to approximately 4 meters (Figs. 4.9, 4.11). As a result, the row of posts became centered along the north-south axis of the room, with two rows of bins on the west and two rows on the east. The new east wall of this room rose to a height of approximately 2.5 meters, and then was stepped back approximately 85 centimeters before extending higher. Its original height could not be determined because of erosion.

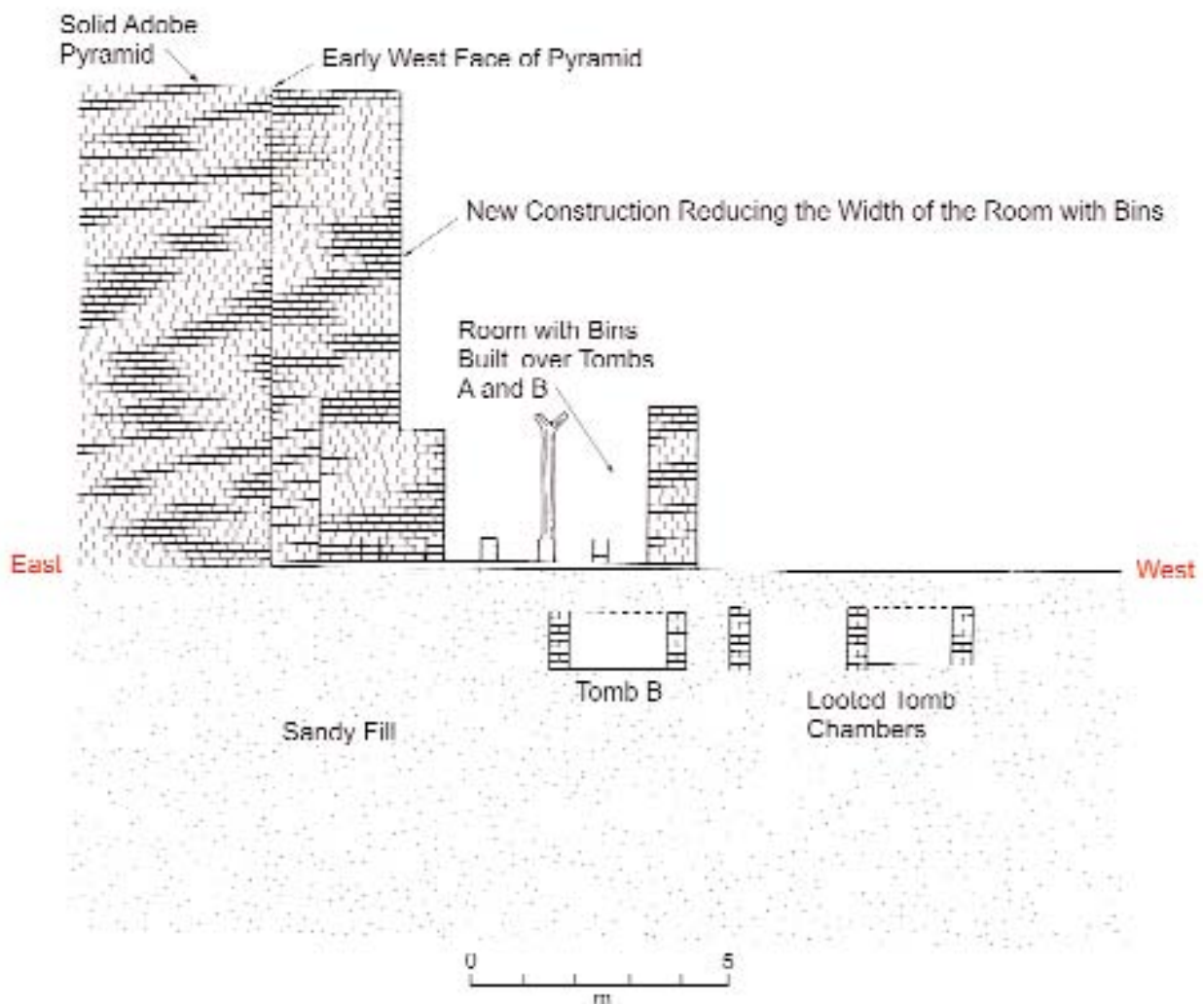

Figure 4.11 STAGE 4: East-west profile as indicated in Fig. 4.6, showing the solid bulk of adobes that reduced the width of the South Room.

STAGE 5

During Stage 5, a significant change occurred in the North Room. Its west wall was dismantled, thus giving access to the room from the west (Figs. 4.12, 4.13). The white bins in the North Room were also removed, and a thin layer of clay was applied to the floor to make it smooth. The walls of the bins that abutted the lower part of the north, south, and east walls of the North Room were also covered with a thin layer of clay (Fig. 4.13). The two posts in this room remained in use, presumably to support a roof.

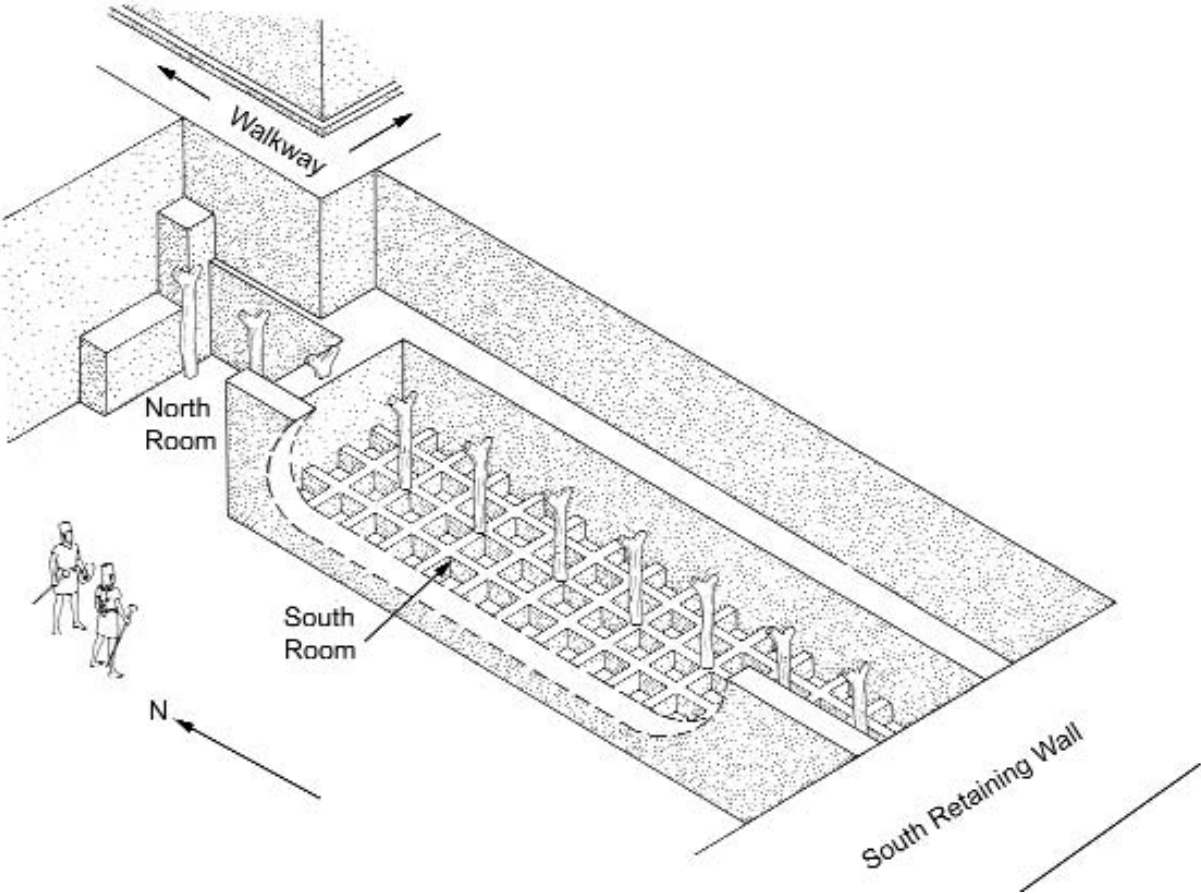

Figure 4.12 STAGE 5: The west wall of the North Room and the bins on its floor were dismantled.



Figure 4.13 The North Room viewed looking east. Note the two postholes near the far wall.

STAGE 6

At this stage, preparation was made for the next major building phase. It would expand the solid construction of the pyramid 2.80 meters to the west, thus covering the remaining portions of both the North Room and the South Room, and would extend the solid bulk of the pyramid out over the area where Tomb A and Tomb B were located.

When Stage 6 began, all of the posts were removed from both the North and South Rooms (Figs. 4.14, 4.15). Removal of the post that was encapsu-

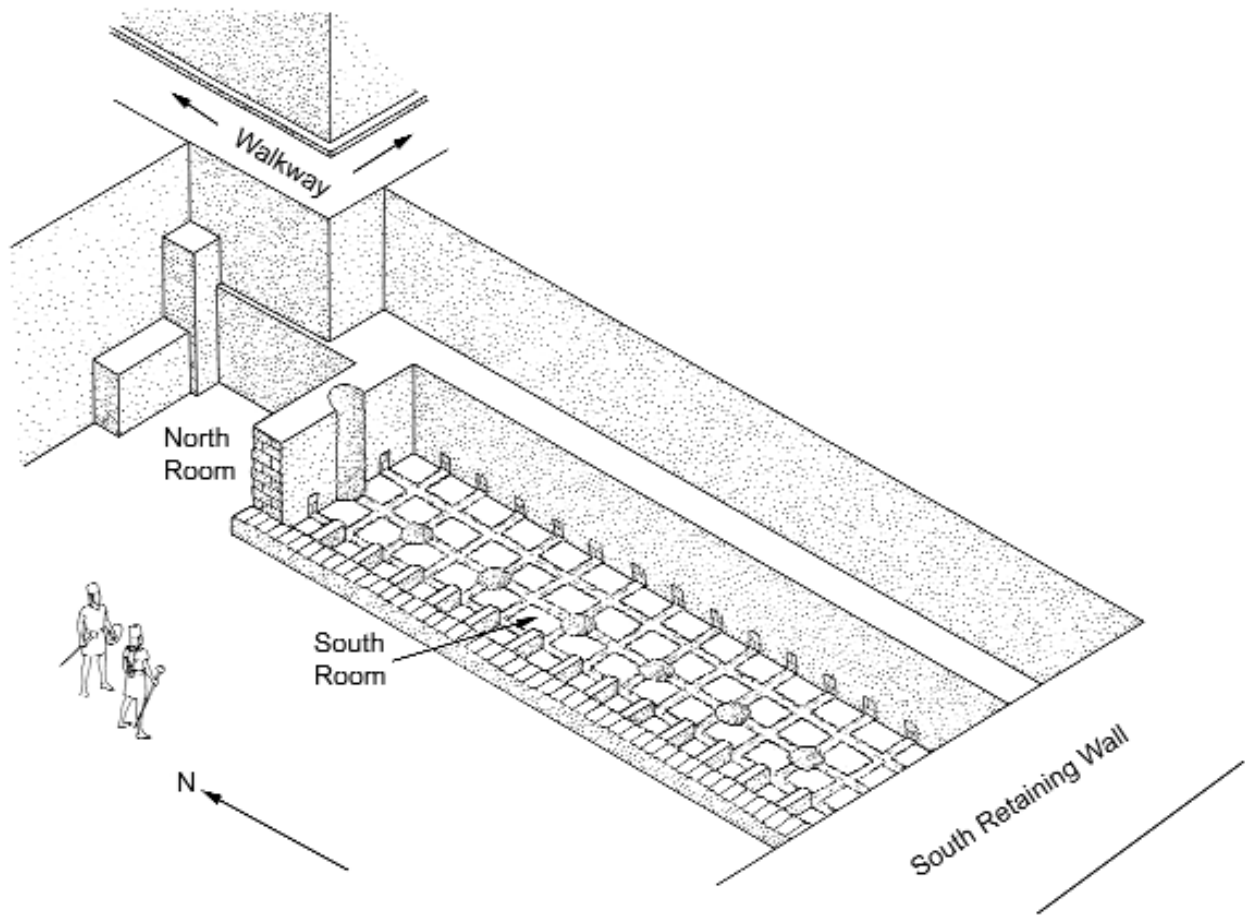

Figure 4.14 STAGE 6: The west wall and the bins of the South Room were dismantled and all of the posts were removed.

lated in the thick east-west wall separating these rooms left a deep scar in the south side of the wall (Figs. 4.14, 4.16).

The west wall of the South Room was dismantled to approximately 30 centimeters above the floor, as were the walls of the white bins adjacent to it. This left these bins approximately 30 centimeters deep, with the upper part of their walls rough and irregular (Fig. 4.7). All other bins in the South Room were dismantled to floor level, leaving squares of white where their floors had been, surrounded by intersecting bands of unpainted clay floor (Figs. 4.14, 4.16).²

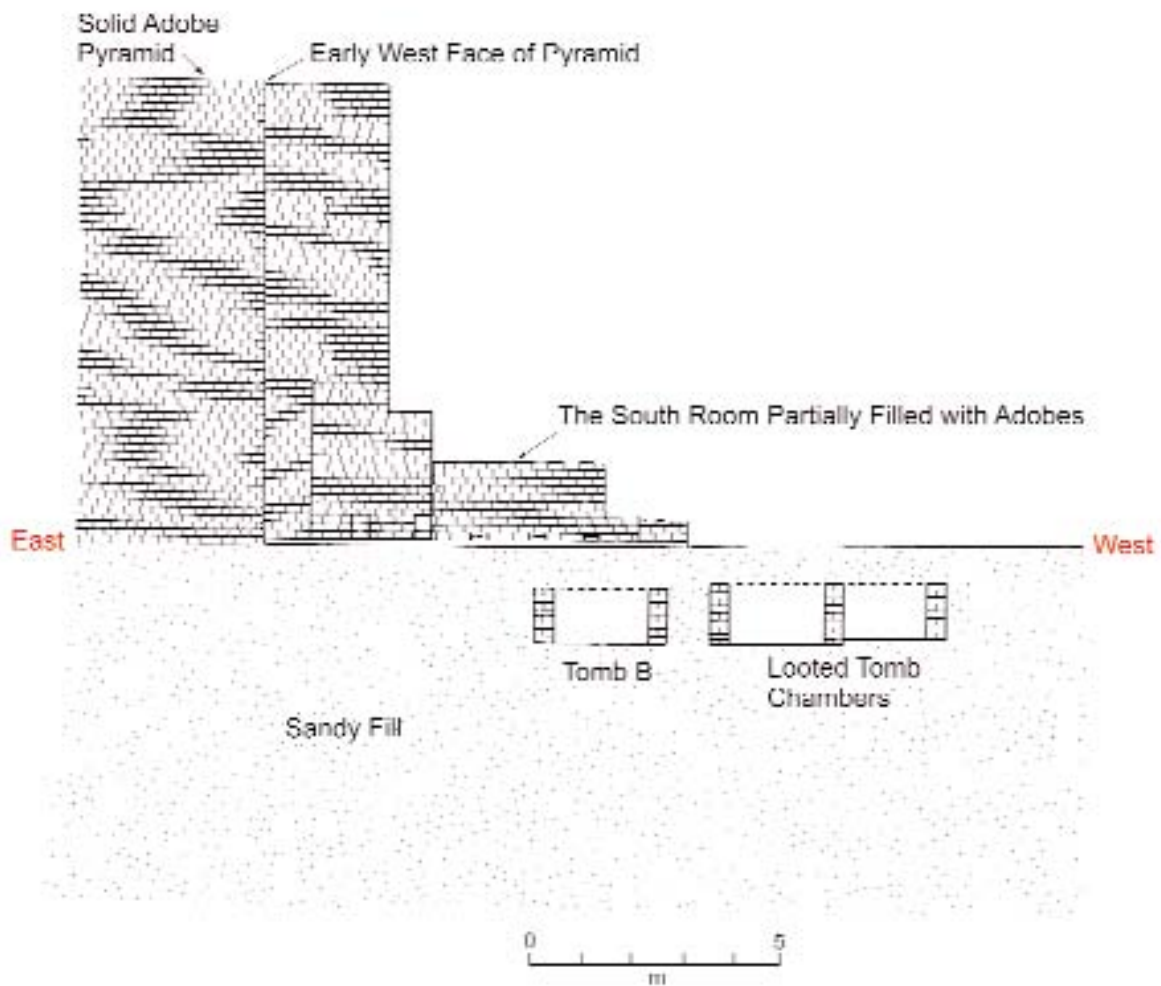

Figure 4.15 STAGE 6: East-west profile as indicated in Fig. 4.6, showing the removal of the posts and bins in the South Room and the dismantled west wall.



Figure 4.16 View of the South Room looking north. Holes along the center of the room indicate where posts were located, and traces of white pigment indicate the floors of the bins that were dismantled to floor level. Note the deep scar on the far wall where a post was removed.

STAGE 7

The floors of the North and South Rooms were covered with layers of adobes. This encapsulated the bins along the west side of the South Room, which had been only partially demolished, and raised the floor of the North Room. The construction involved spreading a layer of clay over a large area and, while the clay was still moist, covering it with a layer of adobes. Dirt mixed with broken adobe was then filled in around the edges of the adobes, and another layer of clay was spread on top of them. Then another layer of adobes was put in place, and more dirt with broken adobe was filled in around them. This procedure was repeated layer by layer to create a large mass of solid adobe masonry (Fig. 4.17).

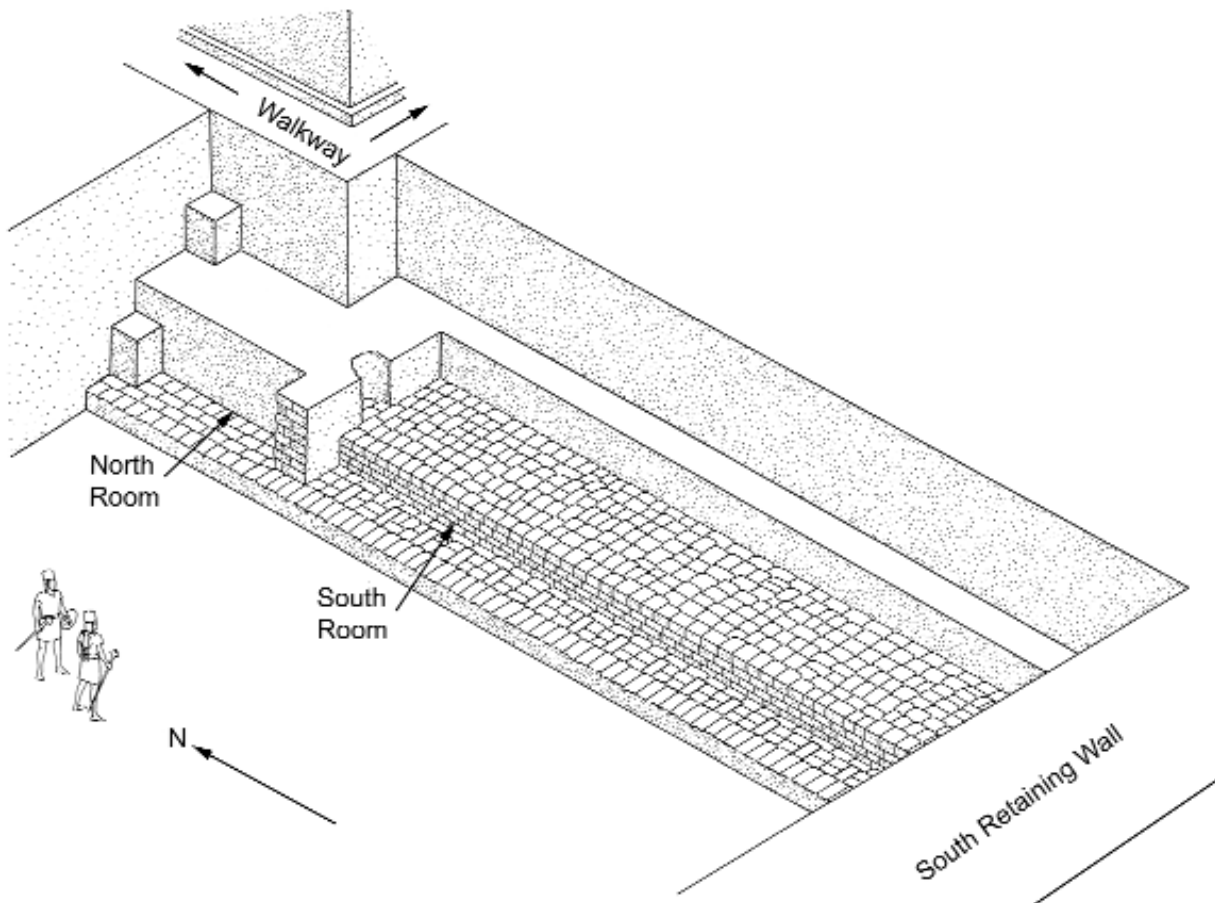

Figure 4.17 STAGE 7: Nearly the entire North Room was filled with solid adobe masonry to the height of the wall separating it from the South Room. The South Room was partially filled with layers of adobes.

Apparently, after the first layer of adobes above Tombs A and B was in place, the builders noticed that the area of new construction above Tomb B was not rigid. Perhaps the roof beams spanning the large burial chamber were sagging under the weight of the newly constructed masonry, or perhaps some of the burials on top of its roof beams had partially decomposed and the weight of the new masonry pressed down on them, causing the layer of adobes to slump. In an effort to correct this, the builders placed a diagonal row of beams on top of the first layer of adobes that had been laid above Tomb B (Fig. 4.18) and filled the spaces between the beams with clay. These diagonal beams helped support the weight of the additional masonry that would be constructed above this tomb, thus preventing the adobes above the tomb chamber from slumping. Once the diagonal beams were in place, construction of the solid adobe masonry continued as before.

There were no diagonal beams above Tomb A. The builders apparently did not feel that the masonry in this area needed to be reinforced, possibly because the burial chamber of Tomb A was considerably smaller than that of



Figure 4.18 Wood beams were placed diagonally over the adobes above Tomb B to prevent the new construction from slumping under the weight of the solid adobe masonry that was being added to fill the South Room.

Tomb B, and the roof beams could span the distance between its walls without sagging under the weight of the masonry above. Also, there were no partially decomposed bodies on the roof of Tomb A that would have compressed under the weight of the overlying masonry, causing the adobes to slump.

The newly raised floor of the North Room was given another layer of clay, and pieces of animal bone were embedded in it along its east side. The bones were fairly evenly spaced at intervals of approximately 65 centimeters. Their function is unknown. Nevertheless, the new layer of clay on the North Room floor suggests that it was in use while the South Room was being filled with successive layers of adobes.

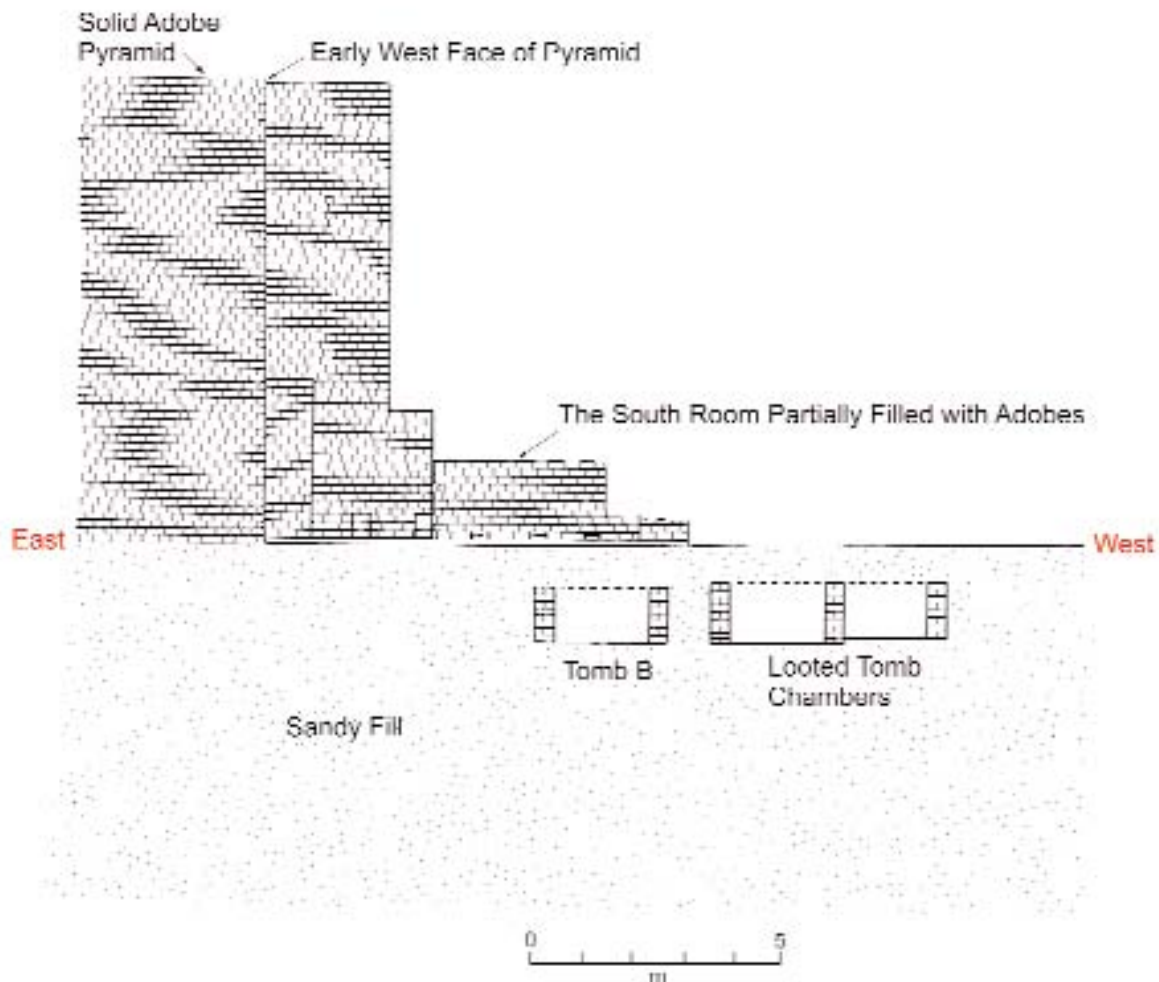

Figure 4.19 STAGE 7: East-West profile as indicated in Fig. 4.6, showing the South Room partially filled with layers of adobes.

STAGE 8

While layers of adobes were being added to fill the South Room, there was a major period of rainfall that caused severe damage to the pyramid. Two deep erosion channels were cut into the west wall of the South Room, and as water cascaded down them it splashed against the upper surface of the recently laid adobes, creating two rounded concavities (Figs. 4.20, 4.21). Water that flowed across the top course of new adobes in the South Room made the adobes fuse with the mortar around them. When this dried, it became a much denser and harder matrix than the adobe levels below them.

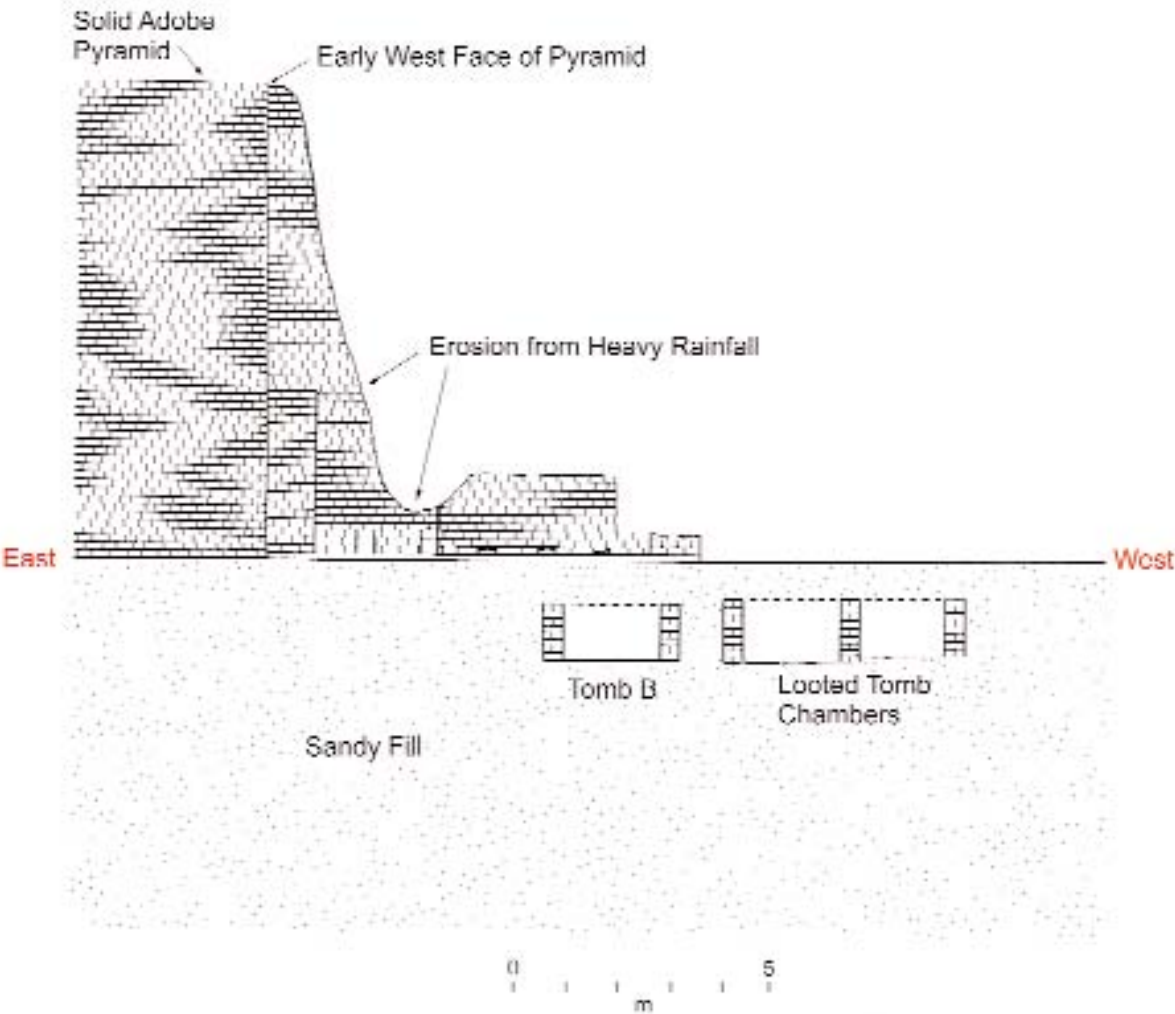

Figure 4.20 STAGE 8: East-west profile as indicated in Fig. 4.6, showing the erosion caused by heavy rainfall.

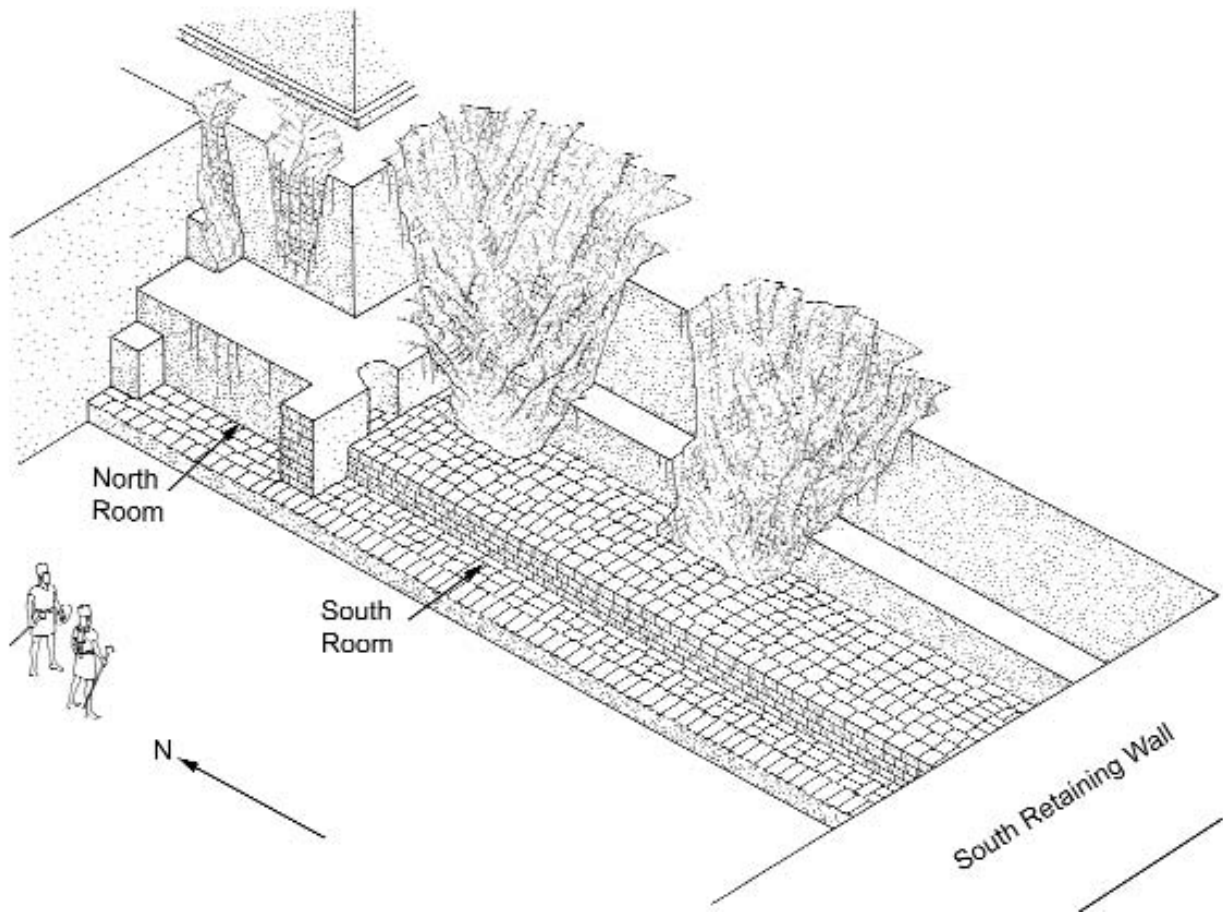

Figure 4.21 STAGE 8: Before the South Room was filled with solid adobe masonry, a period of heavy rainfall cut two large erosion channels in the west wall of the pyramid and created large concavities in the newly constructed masonry .

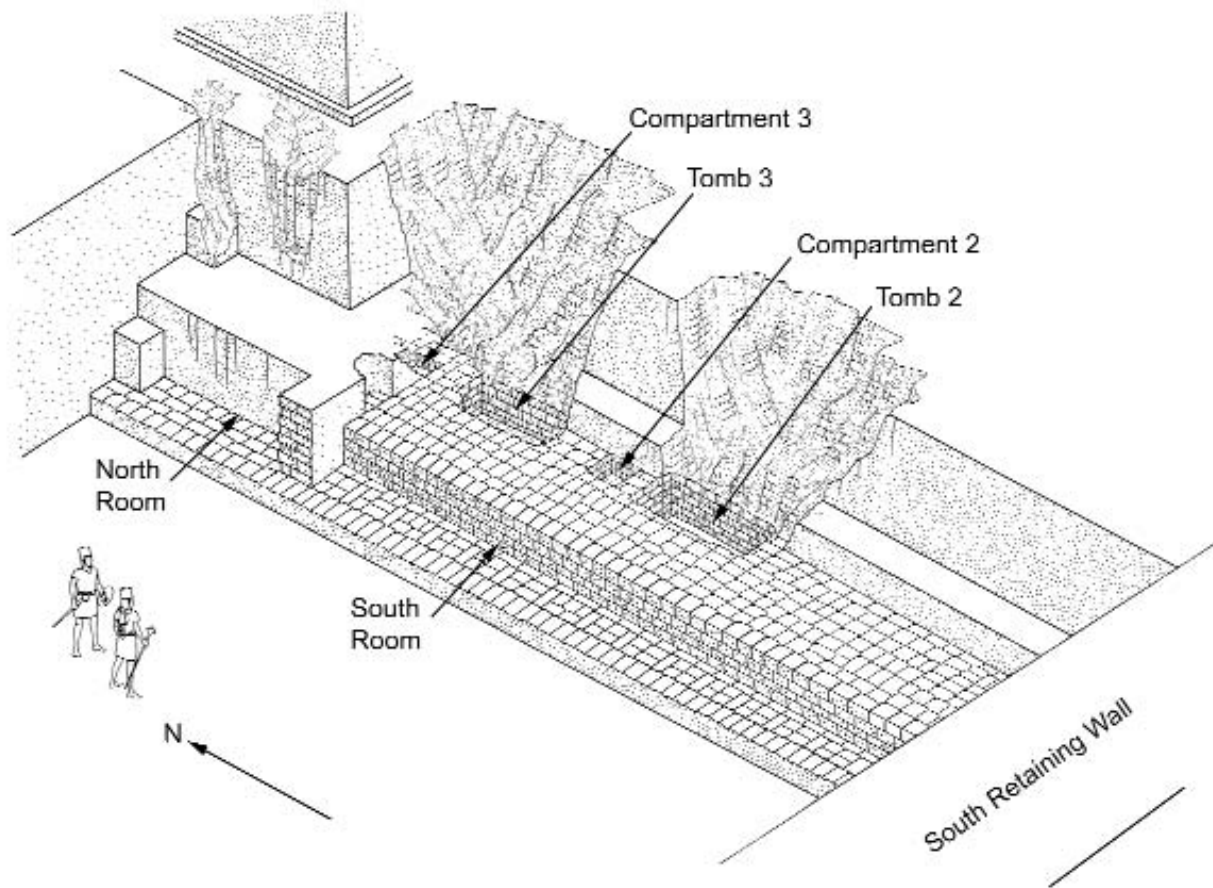

Figure 4.22 STAGE 9: Adobes were removed to enlarge the two eroded concavities in the South Room, thus making them into the burial chambers of Tomb 2 and Tomb 3. A small compartment at the north end of each tomb was also created by removal of adobes.

STAGE 9

After the rains stopped, Tomb 1, Tomb 2, and Tomb 3 were constructed. The location of the burial chambers of Tombs 2 and 3 seems to have been determined by the location of the two rounded concavities that were created by water erosion. These were simply enlarged and deepened to the desired size and shape of burial chambers by breaking out adobes from the recently constructed masonry bulk (Figs. 4.22–4.24).

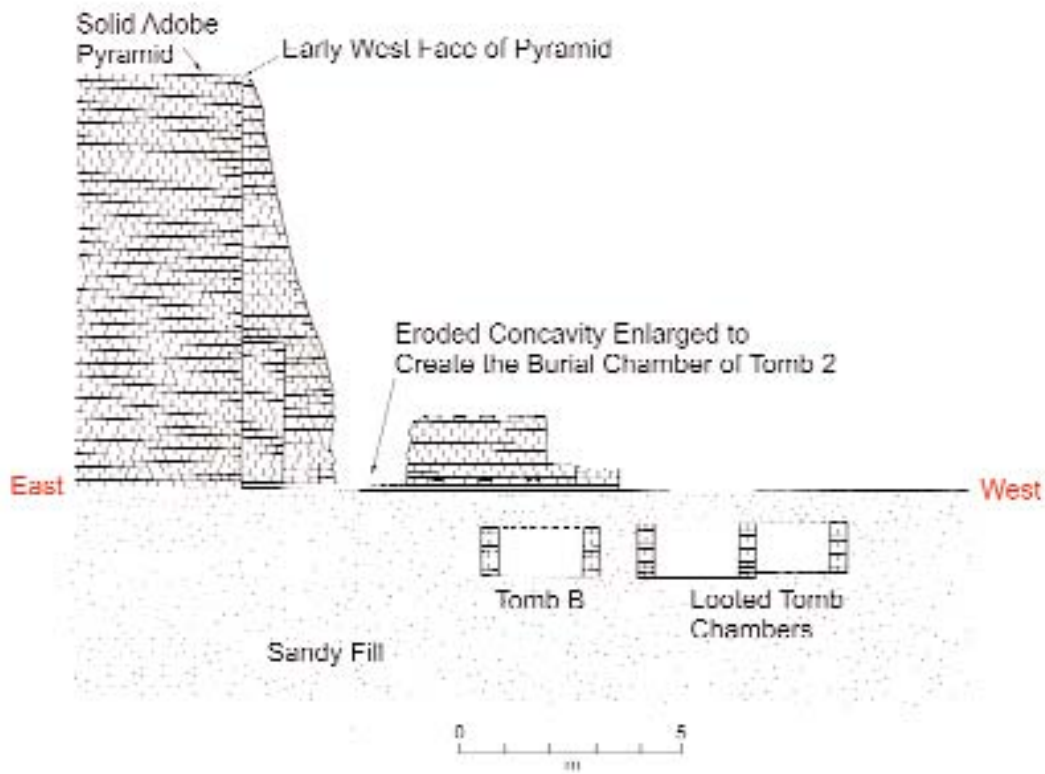

Figure 4.23 STAGE 9: East-west profile as indicated in Fig. 4.6, showing the enlargement of an eroded concavity to create the burial chamber of Tomb 2.

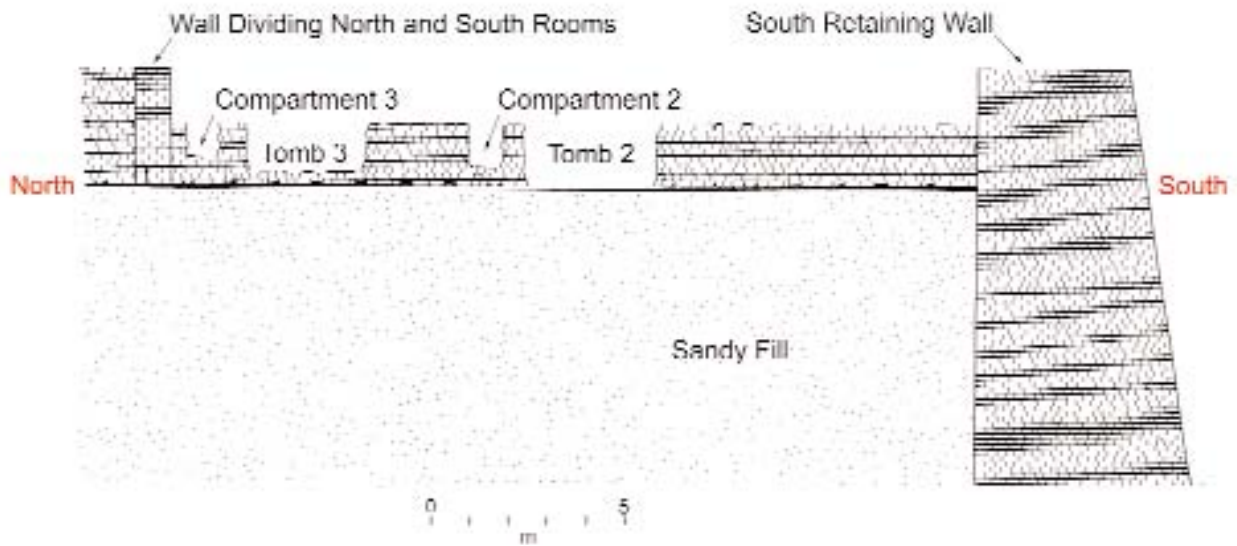

Figure 4.24 STAGE 9: North-south profile as indicated in Fig. 4.6, showing the enlargement of eroded concavities to create the burial chambers of Tomb 2 and Tomb 3.

Clearly, there were numerous successive modifications of the architecture between the time that Tombs A and B were covered over and the time that Tombs 1, 2, and 3 were constructed. This implies that considerable time elapsed between the two sets of tombs. Precisely how much time is impossible to determine, but it must have been a minimum of several years (see Chapter 8).

There is evidence that Tombs 1, 2 and 3 were all constructed within a brief time period. The tombs are numbered in the order that we excavated them; however, Tombs 2 and 3 appear to be slightly earlier than Tomb 1. Therefore, they are discussed first in the chapters that follow.

NOTES

¹ If the roof was flat, placing the posts along the center of the room would have been more functional in evenly distributing the weight of the beams and roofing material.

² The different degree of demolition may be because they were planning to build solid masonry to a considerable height, with considerable weight, above the area they demolished to floor level, whereas the area where the bins were partially left standing was simply to become a low bench, with relatively little weight.

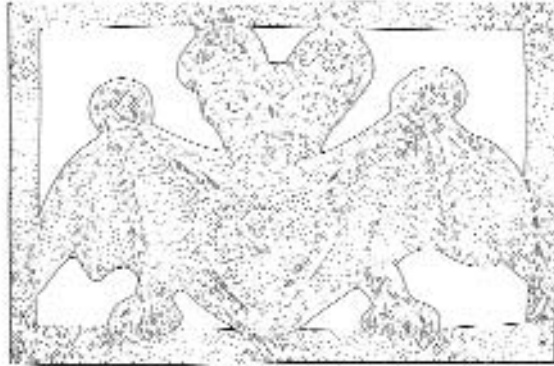

Chapter 5

TOMB 2

Tomb 2 was one of three tombs that were found in the solid adobe construction of the pyramid.¹ All three tombs and their adjacent compartments were located along a north-south axis (Fig. 5.1). The burial chamber of Tomb 2 was in an eroded pocket in the adobe masonry that was created during a period of intense rainfall, when water cascaded down the west face of the pyramid and splashed onto the upper surface of the recently constructed addition (see Chapter 4, STAGE 9). The erosion cut into the new addition and into the west face of the pyramid. The Moche simply enlarged this newly eroded pocket by breaking adobes out of both the old and new construction to create a burial chamber measuring approximately 330 centimeters north-south, 150 centimeters east-west, and 115 centimeters deep. This left the sides of the chamber irregular.

In contrast, the floor of the burial chamber was a smooth clay surface with traces of white pigment. This pigment was not applied at the time the tomb was constructed but remained from the earlier construction of the room with white bins (see Chapter 4, STAGE 3). The builders of the tomb chamber probably discovered this earlier floor accidentally and decided to use it as the tomb floor.

Above the roof of the burial chamber were two skeletons, a human and a llama, lying parallel to one another with their heads to the south (Figs. 5.2, 5.3). The human was a female, approximately 15 years old, lying fully extended on her stomach with her right arm flexed so that her right hand was beneath her right shoulder. A small copper bead was adjacent to the west side of her neck, but it may not have been deliberately placed next to her. It may have simply been in the fill that was put around her body at the time of burial. There were no artifacts associated with the llama.

The young female and llama were probably sacrificed, although there

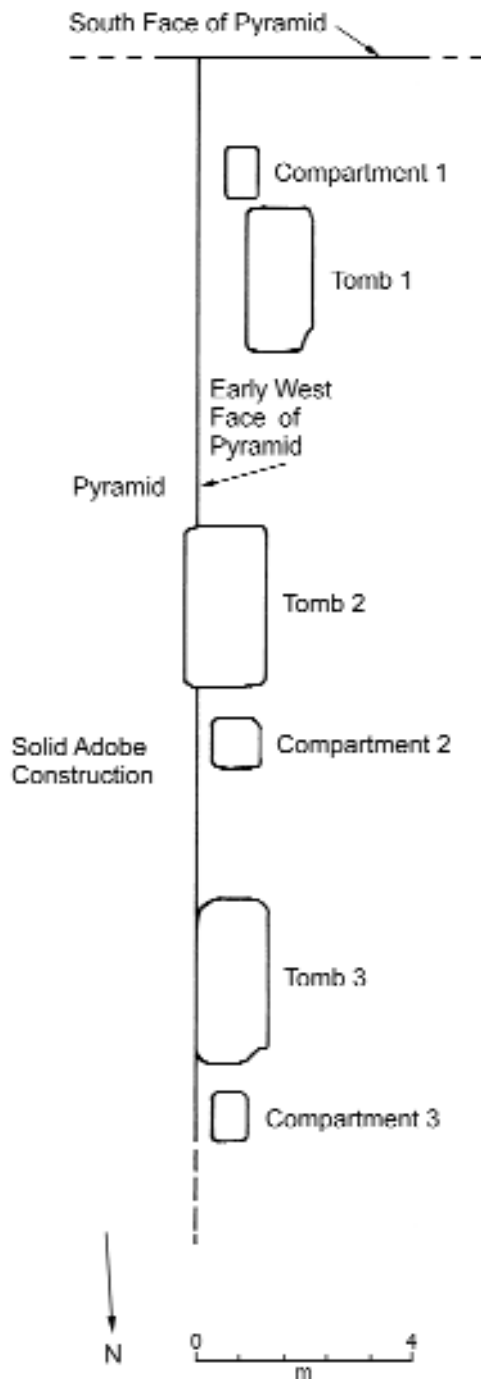

Figure 5.1 Plan of the three tombs in the solid adobe pyramid.

was no sign of violent death. Neither had any traces of textile or cane encasing them. They were lying on a surface of mud bricks with additional mud bricks around and between them, thus creating a separate enclosure for each. Once the bodies were in position, the space around them was filled with dirt and chunks of broken adobe.

The first layer of adobes beneath the female and llama had been laid without mortar. The adobes had been previously used, but were whole and in good condition. Their placement was irregular. In contrast, the second layer of adobes

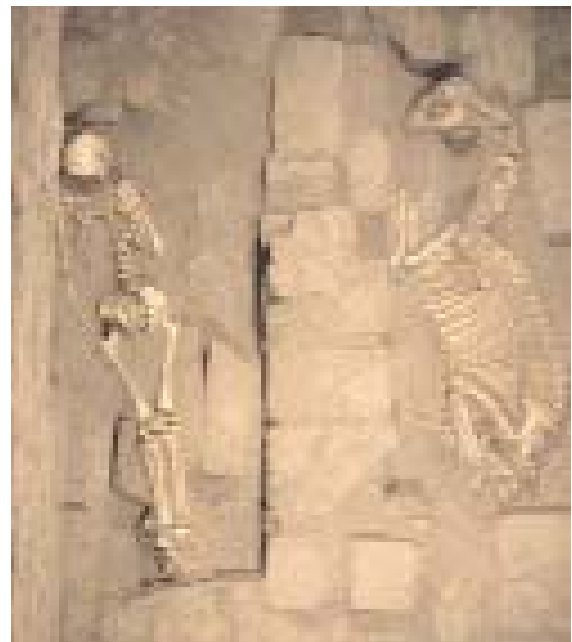

Figure 5.2 The female and llama above the roof of Tomb 2.

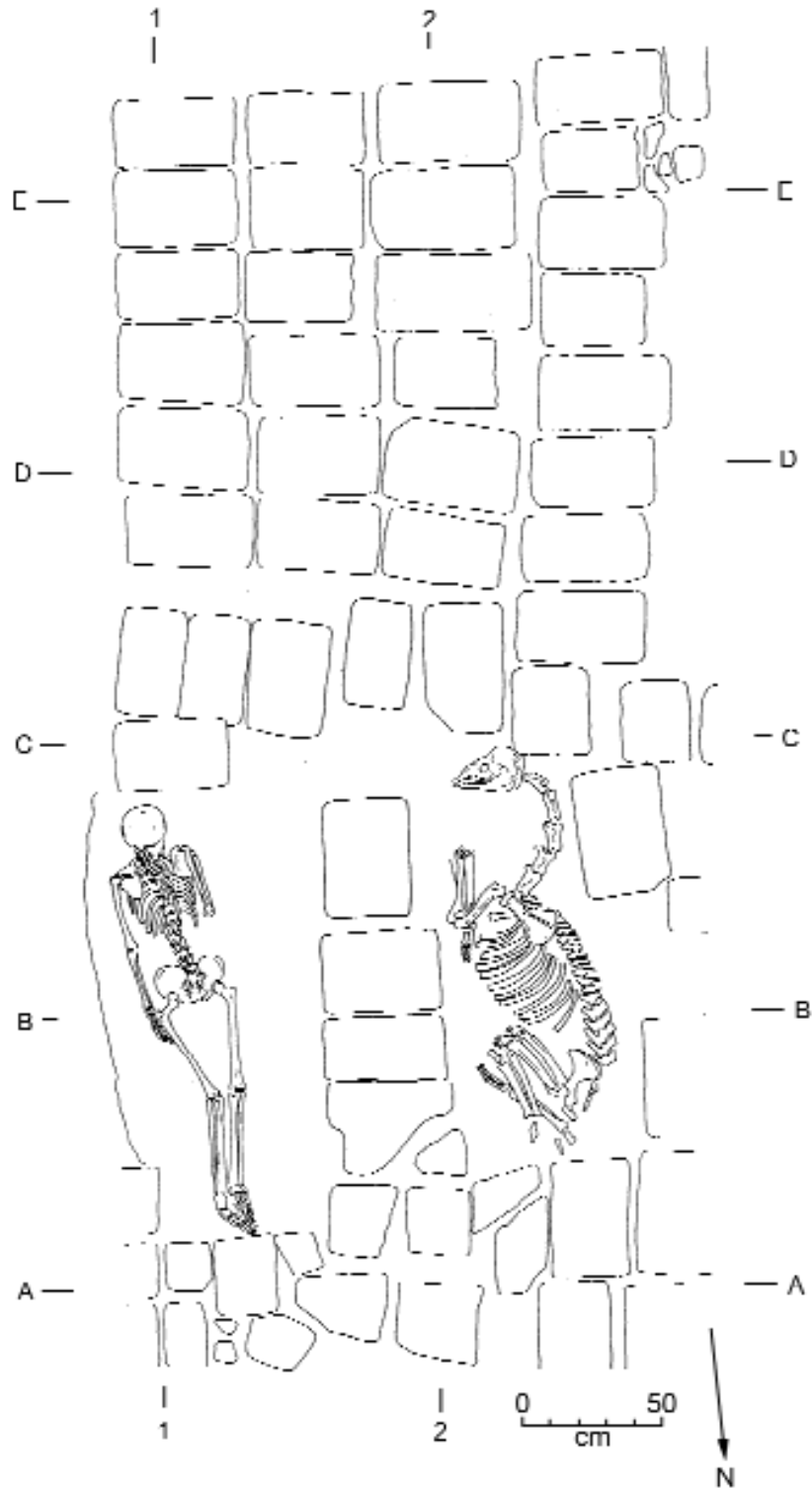

Figure 5.3 Plan of the layer above the roof of Tomb 2 showing the female and llama.

beneath the female and the llama was well ordered. It consisted of 40 adobes, carefully positioned with 20 adobes at the north end separated by a space from 20 more adobes at the south end (Figs. 5.4. 5.5). Each set of 20 was arranged in four rows, with five adobes in each row.



Figure 5.4 The layer of adobes on top of the roof beams. Note the impressions of the decomposed roof beams under the adobes in the foreground.

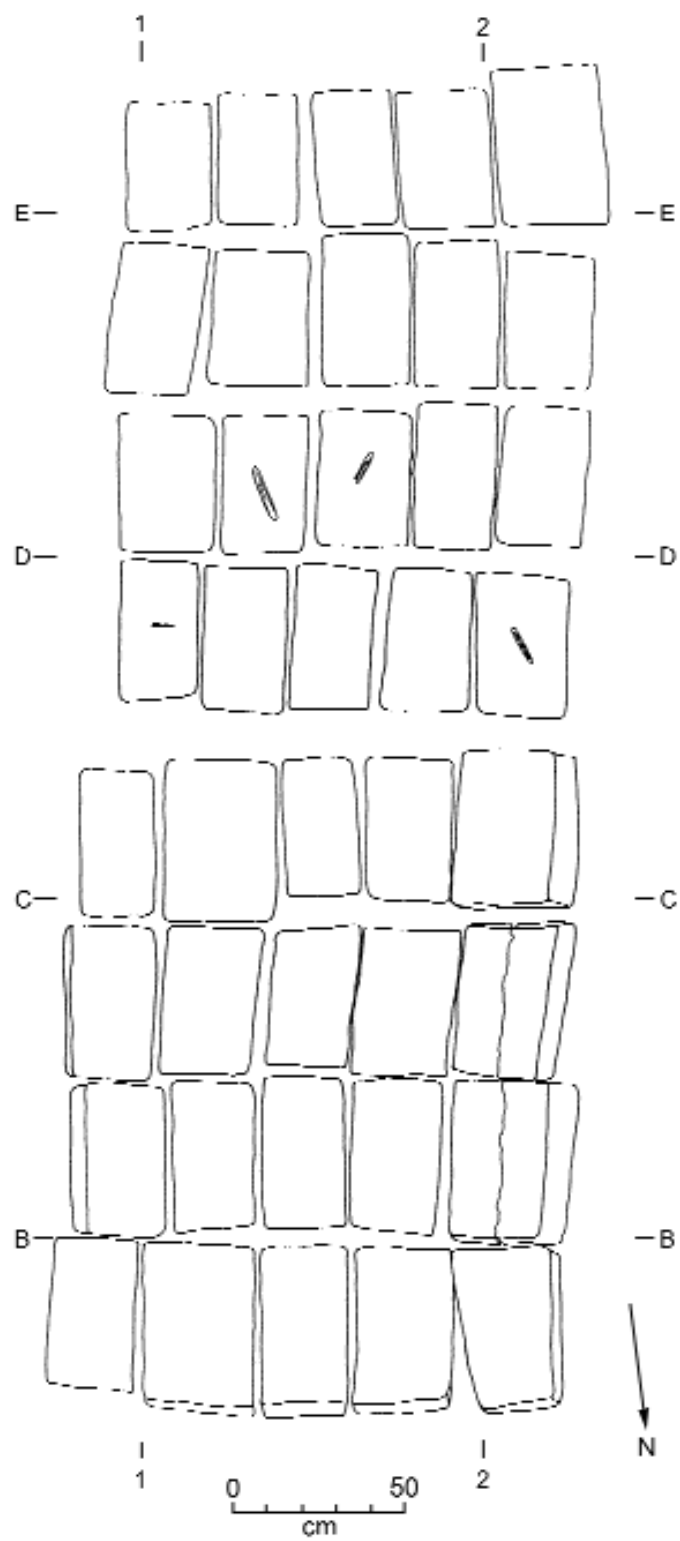

Figure 5.5 Plan of the adobes above the roof beams.

The layer of 40 adobes rested directly on top of wooden beams that formed the roof of the burial chamber. The beams were completely decomposed; only a soft powder remained of what had been wood. Nevertheless, their size and form could be reconstructed from the impressions they left in the soil around them (Fig. 5.6). Ten large beams extended north-south, resting on the edges of the burial chamber. Under these were four transverse beams extending east-west. The east ends of the transverse beams were inserted into holes that had been cut into the west face of the pyramid, while the

west ends rested on the edge of the burial chamber.² One crooked beam was found at the southwest corner of the tomb (Fig. 5.7); its function is not clear.

Near the south end of the tomb there was a length of cane extending east-west on top of the roof beams (Fig. 5.7). It helped support a thick layer of cane extending north-south over the southern one-third of the funerary chamber. Although this cane layer was badly decomposed, it appears to have been originally about 10 centimeters thick. This would have created a substantial roof over the south end of the tomb — over the head of the tomb's occupant in the burial chamber below.³



Figure 5.6 Cleaning the impressions of the decomposed roof beams.

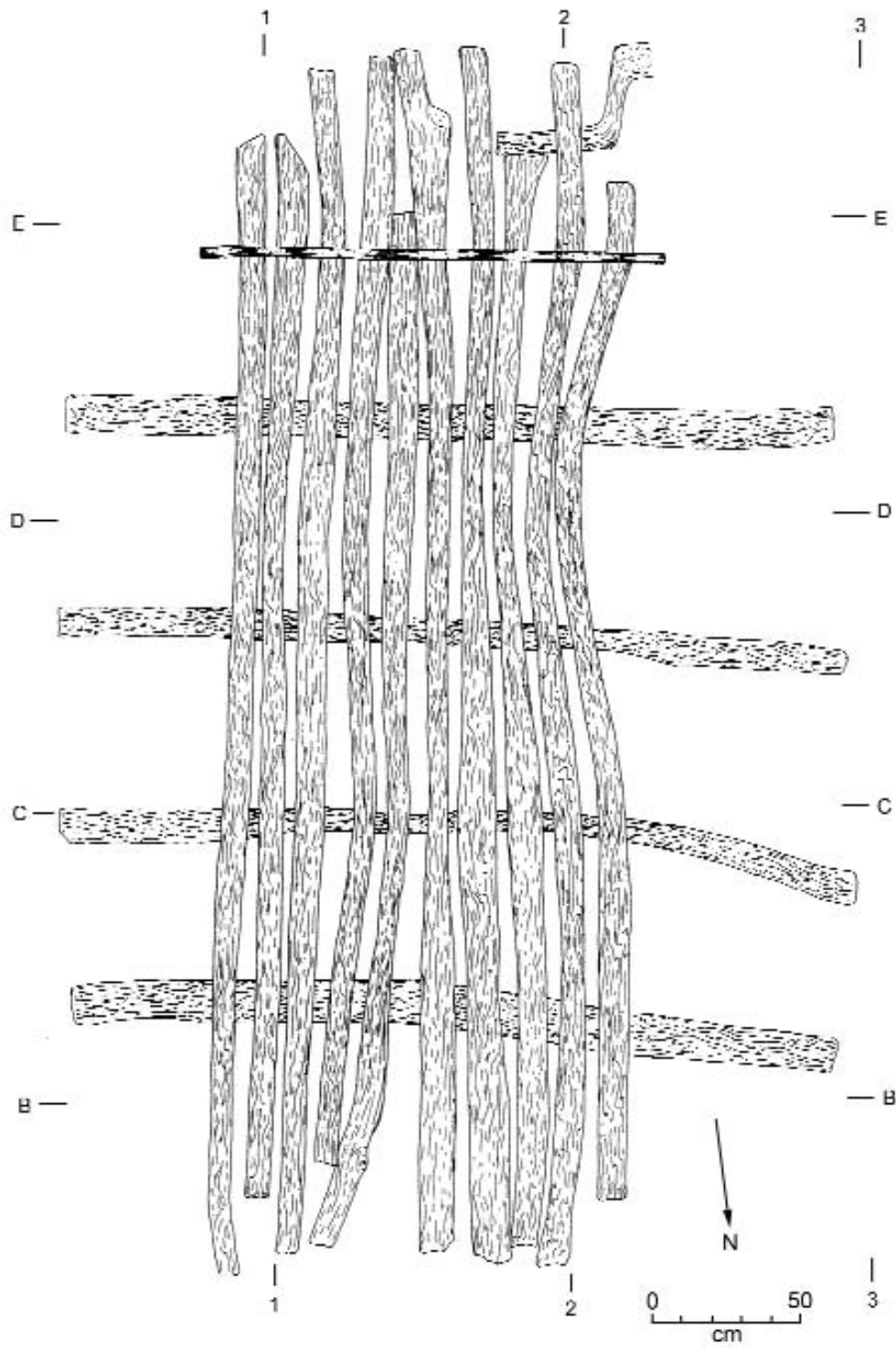

Figure 5.7 Plan of the roof beams.

The burial chamber was filled with tightly compacted sand that tended to be banded horizontally or in slightly tilted layers. In some areas there were thin laminae of fine clay among these bands. These deposits were not there when the roof was constructed but accumulated slowly and intermittently during subsequent centuries — presumably during periods of rainfall, when water seeping through the pyramid's adobe matrix would have washed sediments into the tomb chamber. At first only small amounts would have entered, but as time passed and the roof began to decompose, greater quantities of material were deposited.⁴ There were also some chunks of broken adobe within the bands of sand and clay. They apparently broke off the side walls or fell through the roof while the sand and clay were filling the chamber.

The clay floor of the burial chamber had been covered with approximately 2 centimeters of grayish white sand.⁵ All of the contents of the chamber were then placed on top of this sand. The principal individual was in the center of the floor, wrapped in a large bundle of textiles (Figs. 5.8, 5.9). The sides and upper portion of the bundle were then covered with a thick layer of fine, moist clay. This clay shell had broken with the compression of material above it as the roof decomposed. Large chunks of it were found on top of the decomposed textiles of the funerary bundle. The clay near the floor, in most areas, was well preserved. At the south end of the bundle the clay was approximately 11 centimeters thick, and became thinner toward the north end.

The clay was extremely well refined, consisting of clay platelets with almost no impurities. When we conducted experiments to determine its suitability for making ceramic vessels, it proved to be ideal for that purpose. Even without adding temper, it did not crack during either drying or firing. Moreover, as it dried, its surfaces could be burnished to achieve a very glossy appearance. Thus, encasing the funerary bundle with this clay appears to have been a deliberate use of very high-quality material.



Figure 5.8 The floor of Tomb 2 with the funerary bundle in the center. Remnants of the clay that had encased it can be seen around the margins of the bundle. Ceramics and animal remains were placed near the corners of the chamber.

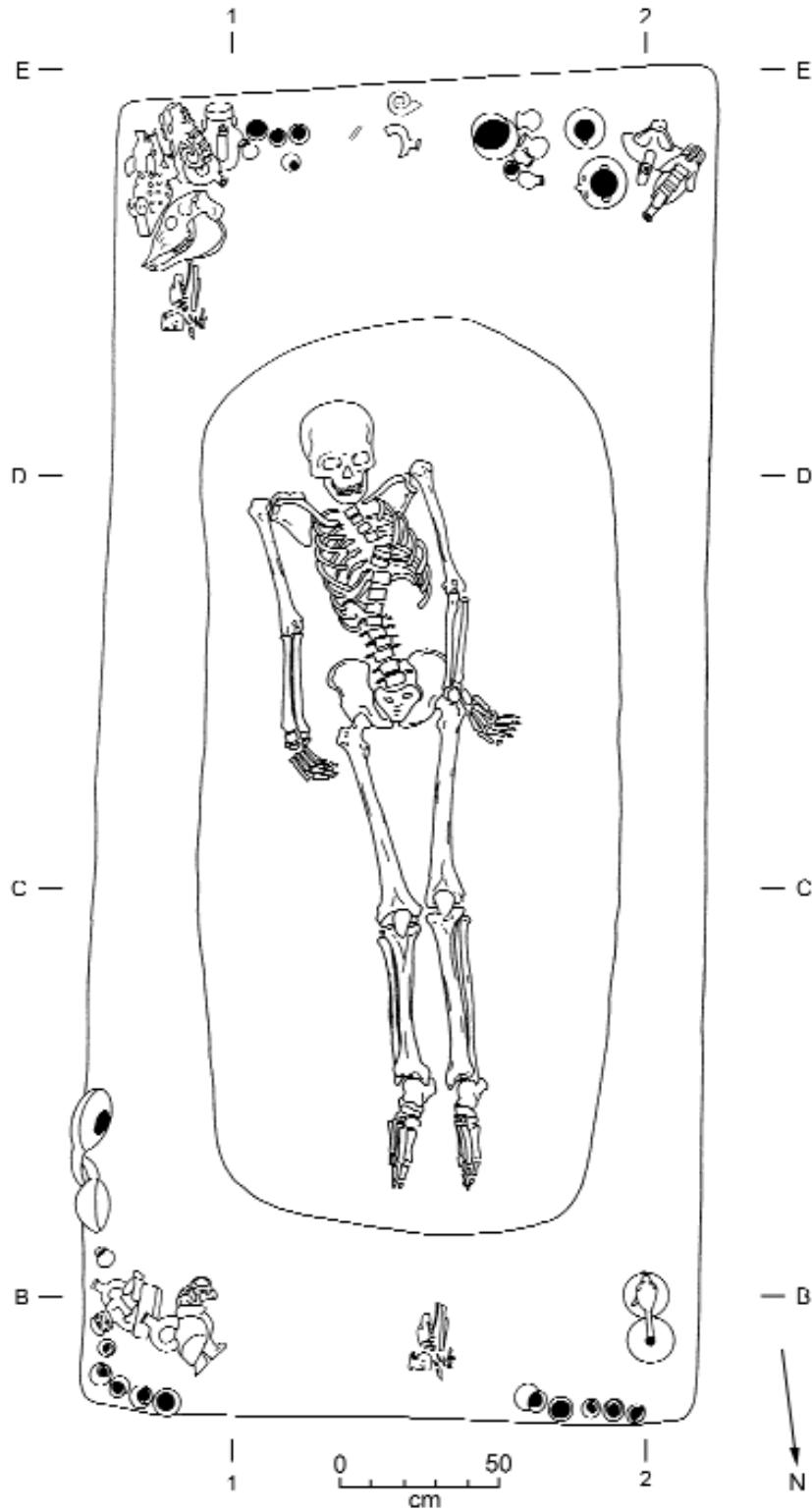

Figure 5.9 Floor plan of Tomb 2 showing the funerary bundle and the objects placed near the corners of the chamber.

Because the clay was still moist when it was placed over the bundle, its inner surface retained impressions of the textile that formed the bundle's outer wrapping — a coarse twill weave cloth, almost certainly made of cotton (Fig. 5.10). Its outer surface carried impressions of a herringbone weave mat that had covered it (Fig. 5.11). This mat had almost entirely decomposed, and thus its placement and dimensions could not be reconstructed. It is clear, however, that it covered the southern half of the funerary bundle and extended over much of the floor at the south end of the burial chamber.

A great quantity and variety of objects had been wrapped inside the



Figure 5.10 Twill weave textile impression from the interior of the moist clay that was packed around the funerary bundle (width 11.5 cm).



Figure 5.11 Herringbone weave impression from a woven mat that was placed over the exterior of the moist clay packed around the funerary bundle (height 8.7 cm).

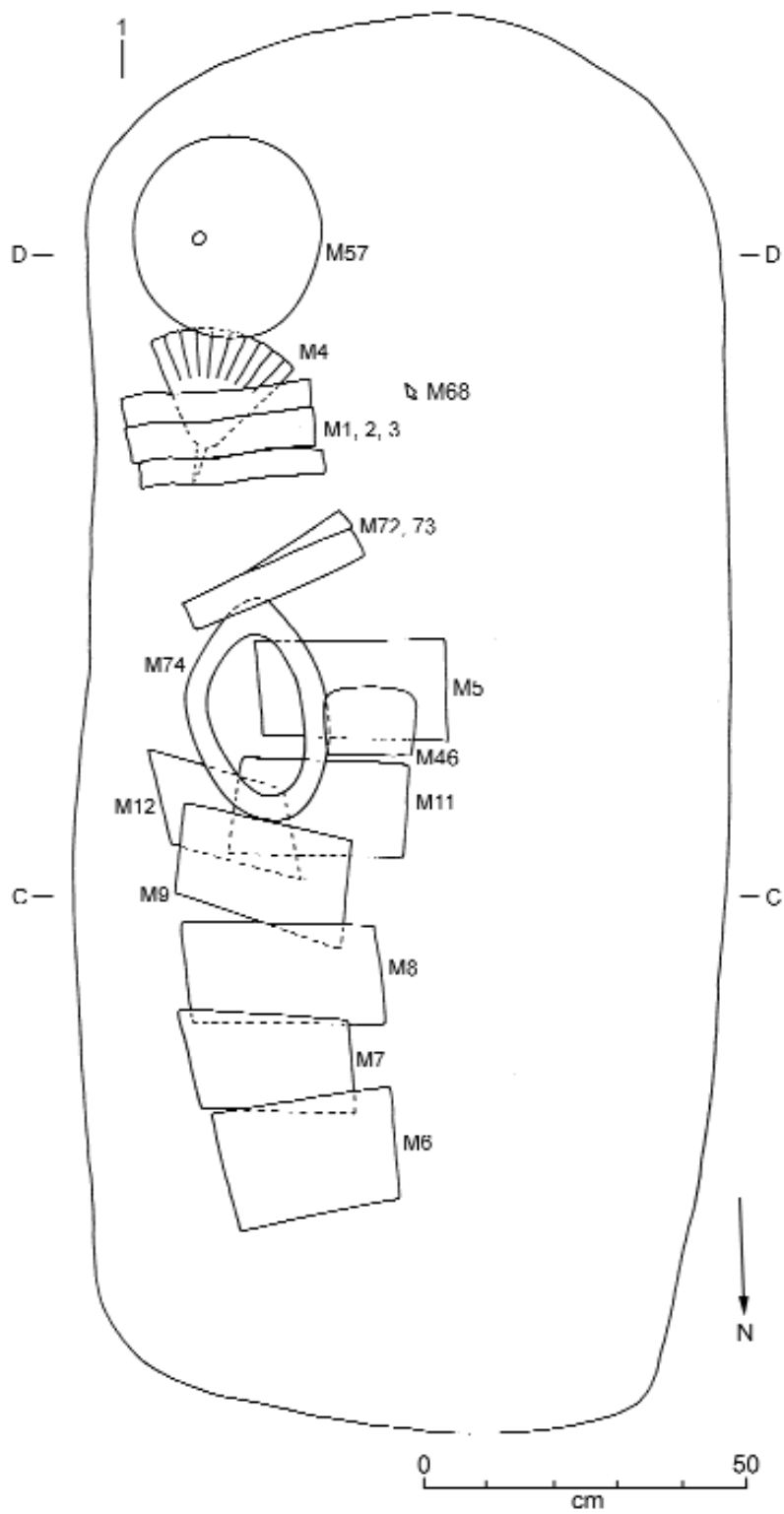

Figure 5.12 Plan of the objects in Layer 1 inside the funerary bundle.

funerary bundle, but because the textiles had decomposed to a powdery mass, it was not possible to determine the relationship between distinct textile layers and the objects wrapped within them. Therefore, the objects were arbitrarily recorded in six successive layers as they were excavated, and the description that follows is organized according to these layers.

LAYER 1

In the first layer (Fig. 5.12) there was a large copper bowl, shaped like a gourd, with a dimple at the center of its base (Fig. 5.12 M57). It was upside down near the south end of the bundle (Fig. 5.13). There was a small pair of gilded copper tweezers northwest of it (Fig. 5.12 M68, Fig. 5.14) and an axe-like copper implement over the central part of the bundle (Fig. 5.12 M46, Fig. 5.15). The latter originally had a wooden handle that fit into its base, held in place with copper rivets.



Figure 5.13 Large copper bowl shaped like a gourd M57 (diameter 35.5 cm).

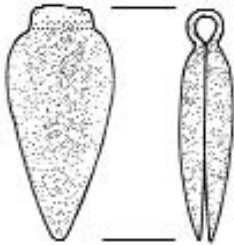

Figure 5.14 Tweezers M68 (height 3.4 cm).

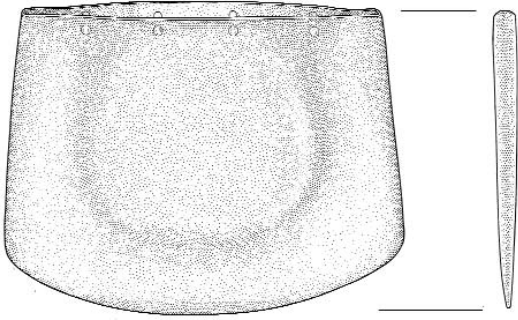

Figure 5.15 Axe-like copper implement M46 (height 10.4 cm).

In the powdered residue of decomposed textiles along the upper part of the bundle, there were ten headdresses. Most were made of open-ended cylinders of basketry that would fit over the head like a crown. The cylinders were made with coils of junco grass (*Juncus* sp.) bound with white cotton thread and then covered with textile. Most of them had platelets of gilded copper attached to the textile around the periphery of the basketry cylinder (e.g., Figs. 5.16–5.21). The platelets were of two types: small undecorated platelets suspended horizontally from wire rings along the top and bottom borders of the cylinder, and large decorated platelets sewn to the central portion. Some of the headdresses had decorated platelets only in front, while the back was covered with columns of identical small rectangular platelets that formed borders around the top and bottom of the cylinders (e.g., Figs. 5.16, 5.18).

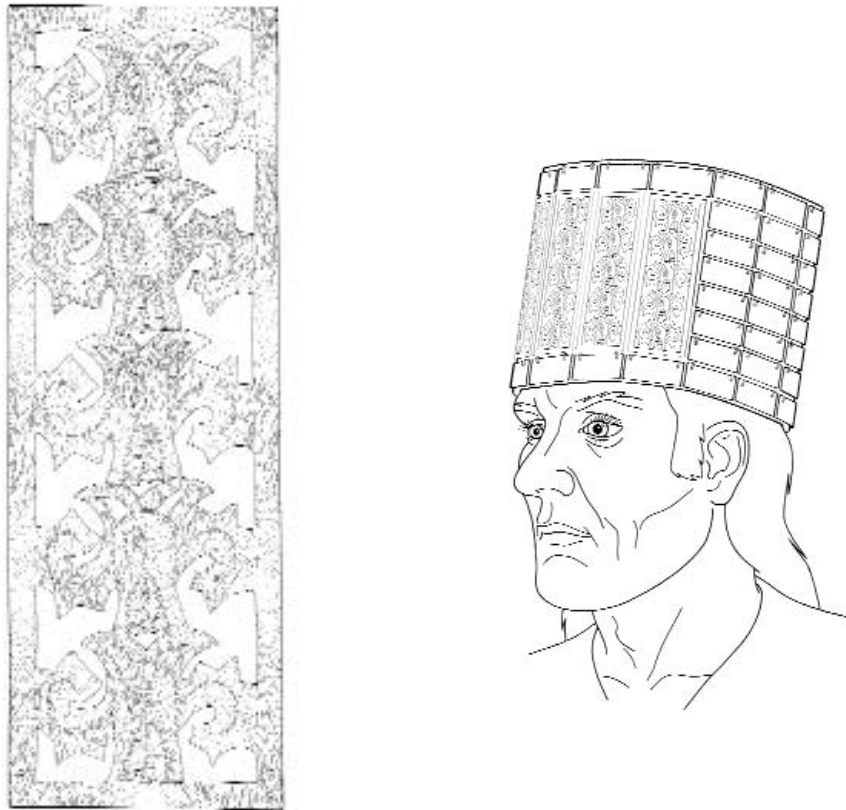

Figure 5.16 Headdress M6. Left, one of the platelets (height 12.2 cm). Right, original appearance of the headdress.

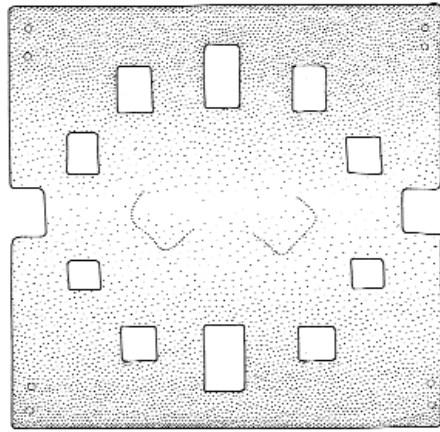

Figure 5.17 Headdress M7. Left, one of the platelets (height 4.1 cm).
Right, original appearance of the headdress.

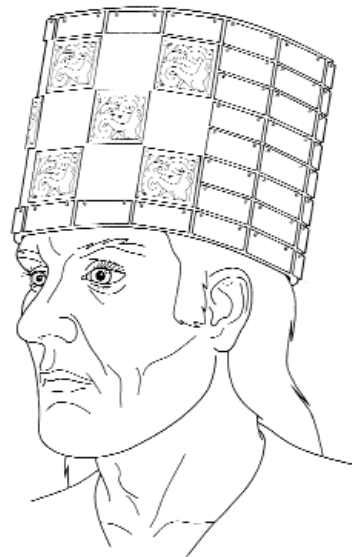
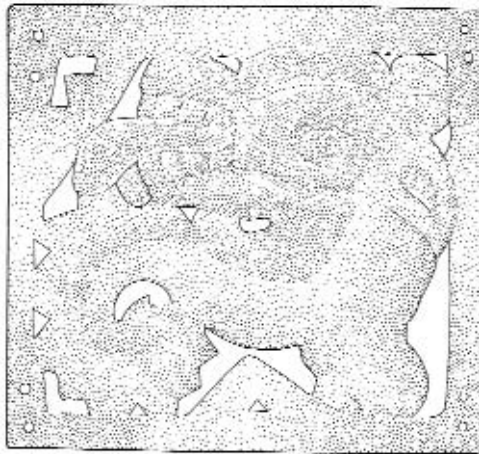

Figure 5.18 Headdress M8. Left, one of the platelets (height 3.9 cm).
Right, original appearance of the headdress.

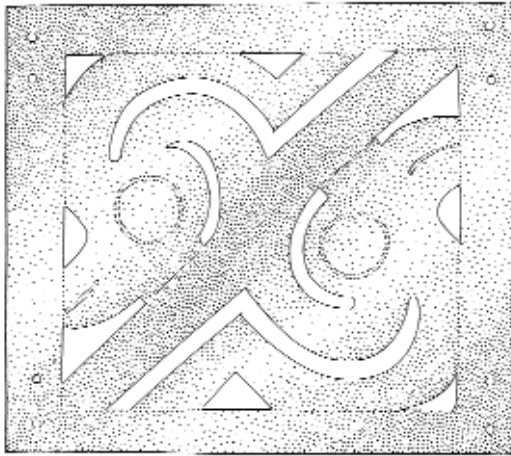

Figure 5.19 Headdress M9. Left, one of the platelets (height 4.1 cm).
Right, original appearance of the headdress.



Figure 5.20 Headdress M12. Left, one of the platelets (height 12 cm).
Right, original appearance of the headdress.

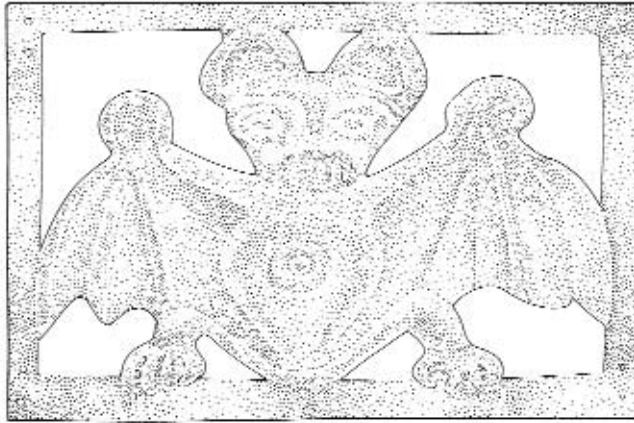

Figure 5.21 Headdress M11. Left, one of the platelets (height 3.9 cm). Right, original appearance of the headdress.

At the time of the burial, each of the cylindrical headdresses had been turned on its side and flattened before it was placed over the body. Although the basketry and textile material used to construct the headdresses had almost completely decomposed, the platelets were still in position (Fig. 5.22).⁶ They were usually found spread over a distinct rectangular area, which is outlined on the drawings of the objects inside the funerary bundle (Fig. 5.12).



Figure 5.22 Headdress platelets in situ. Headdress M6 in the center portion of the photograph and platelets of Headdress M7 in the upper portion.

The headdresses were in a north-south row over the east side of the individual's body, usually with the southern edge of one headdress overlapping the northern edge of the adjacent one (Fig. 5.12). This overlapping indicated that the first headdress was placed over the upper part of the body, near the head, and the others were then added sequentially toward the feet.

Each headdress was unique, and many different styles were represented. The headdress at the north end of the funerary bundle (Fig. 5.12 M6), presumably the last placed over the body, had tall rectangular platelets in front and columns of border platelets in back (Fig. 5.16). Each of its front platelets depicts five Crested Animal heads. The Crested Animal is a mythical figure that is frequently depicted in Moche art. It has a large crest that spirals back from the top of its head and a smaller crest spiraling over its snout. In this case, the spiral over the snout is not shown but the head is nearly identical to two Crested Animals depicted on ceramic vessels in this tomb (e.g., Fig. 5.120), and the spiral from the bottom of each head may represent a seahorse tail.

The next three headdresses (Fig. 5.12 M7, M8, M9) had rectangular platelets arranged in a checkerboard fashion in three horizontal rows (Figs. 5.17–5.19). The platelets on these headdresses depict a geometric pattern (Fig. 5.17), the Crested Animal with the lower body of a seahorse (Fig. 5.18), and two stylized bird heads (Fig. 5.19).

The next headdress (Fig. 5.12 M11) also had tall rectangular platelets with three sets of stylized bird heads (Fig. 5.20). The next headdress (Fig. 5.12 M11) had platelets depicting bats with their wings spread (Fig. 5.21), sewn to the headdress in three horizontal rows, the center row having a space between each platelet.

The next headdress (Fig. 5.12 M74) was unique among those in the funerary bundle, since it was not made over a basketry cylinder. Although the organic material had almost completely decomposed, the headdress appears to have been a donut-shaped ring of junco grass that was covered with textile, with numerous gilded copper discs attached with wires to its exterior.⁷

All of the remaining headdresses in this layer of objects were made on basketry cylinders. One (Fig. 5.12 M5) had small rectangular platelets with geometric representations of two rays, one facing up and the other facing

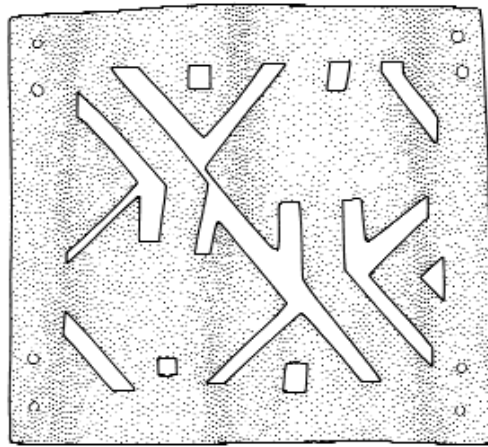

Figure 5.23 Headdress M5. Left, one of the platelets (height 4.1 cm). Right, original appearance of the headdress.

down (Figs. 5.23, 5.24). The design is created entirely with cutout sections instead of low relief. The back side of the platelets had impressions of feathers that suggest they had been sewn to a basketry cylinder covered with a feathered textile (Fig. 5.24).



Figure 5.24 A platelet from Headdress M5 (height 4.1 cm) with impressions of feathers in the surface corrosion.

The final two headdresses in this layer were not made of platelets of gilded copper but rather of decorated bands of gilded copper that were sewn around the exterior of basketry cylinders. The first (Fig. 5.12 M72, 73) had two bands depicting Decapitators, anthropomorphized creatures holding tumis (Figs. 5.25, 5.26). The two bands were found overlapping one another, suggesting that the headdress was only two-thirds the height of the other headdresses that had been excavated.



Figure 5.25 A portion of the band of Headdress M72, 73 after cleaning (height 4.2 cm).



Figure 5.26 Headdress M72, 73. Left, a portion of one of the bands (height 4.2 cm). Right, original appearance of the headdress.



Figure 5.27 A portion of a decorated band from Headdress M1, 2, 3 after cleaning (height 4.4 cm).

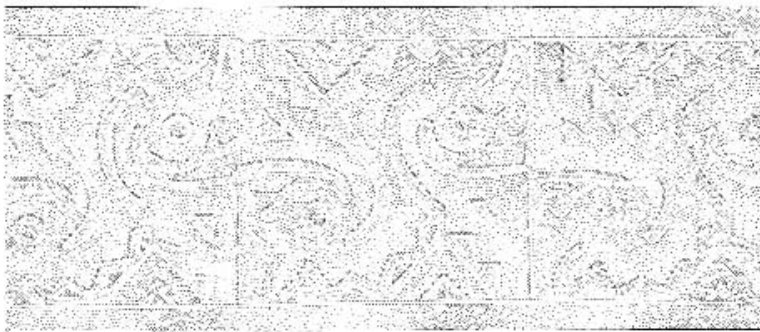

Figure 5.28 Headdress M1, 2, 3. Left, a portion of one of the decorated bands (height 4.4 cm). Right, original appearance of the headdress.

In contrast, the bands of the second headdress (Fig. 5.12 M1, 2, 3, Fig. 5.27) were separate from one another when found, suggesting that they had been sewn around the top and bottom of a cylinder of more typical height (Fig. 5.28). The bands were decorated with a repeating pattern of two bird heads. Beneath this headdress was a gilded copper headdress ornament (Fig. 5.12 M4) in the form of a plume with ten feathers (Fig. 5.29).



Figure 5.29 Gilded copper plume M4 after cleaning (height 24.9 cm).

LAYER 2

In the second layer of objects within the funerary bundle (Fig. 5.30) there were two more headdresses. One (Fig. 5.30 M13, 14) was made with bands decorated with a complex geometric scroll motif (Fig. 5.31). The space between the bands when they were in situ suggests that they had been sewn around the top and bottom of a tall basketry cylinder.

The second headdress in this layer (Fig. 5.30 M15) is unusual in having gilded copper platelets in the form of volutes (Fig. 5.32). Though distinct from the rectangular platelets sewn to other headdresses, the volutes were arranged in formal vertical columns to provide a similar appearance.

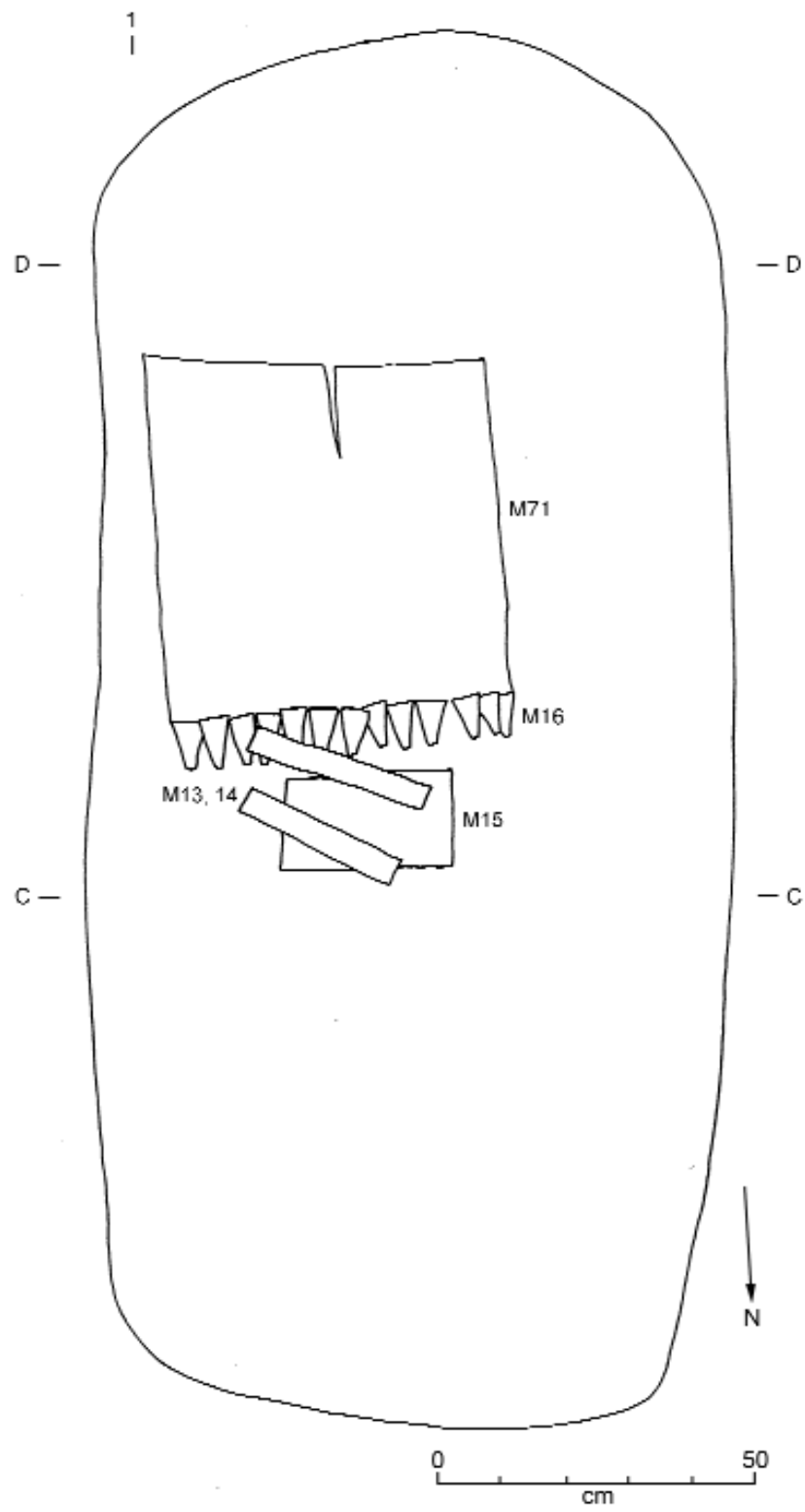

Figure 5.30 Plan of the objects in Layer 2 inside the funerary bundle.

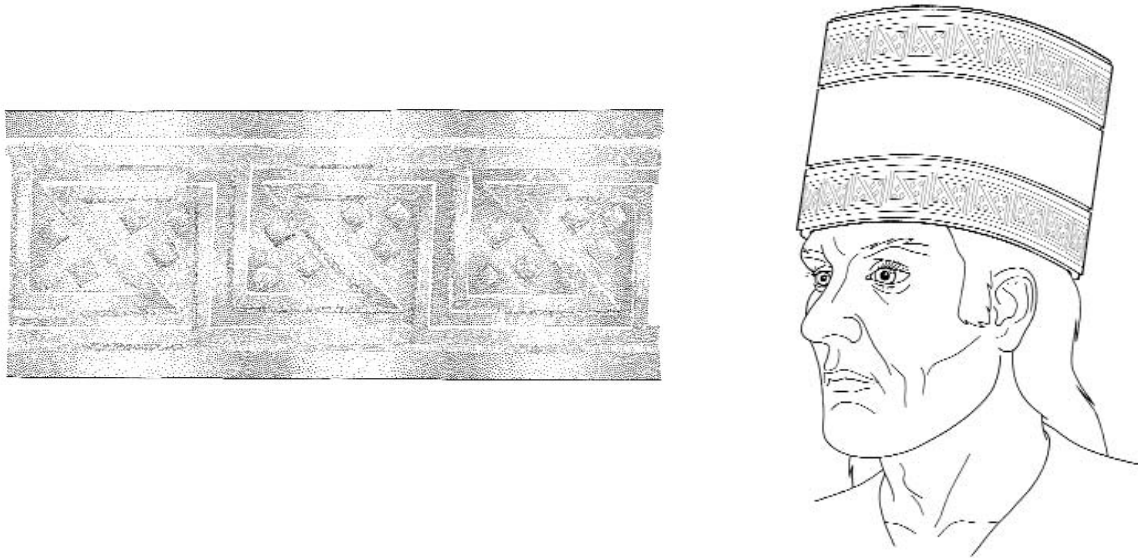

Figure 5.31 Headdress M13, 14. Left, a portion of one of the bands (height 4.1 cm).
Right, original appearance of the headdress.

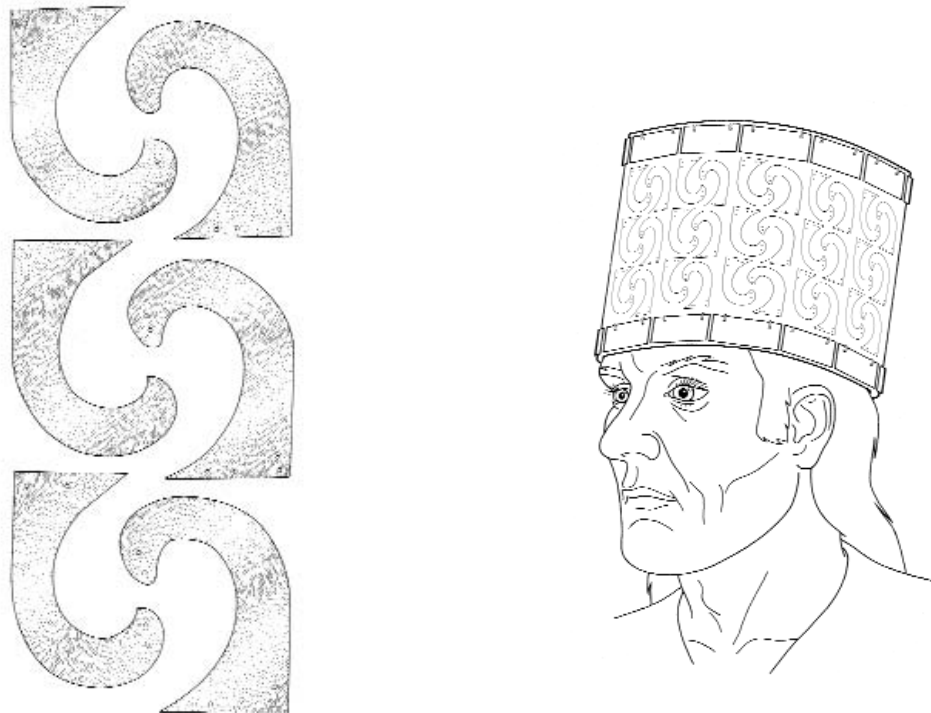

Figure 5.32 Headdress M15. Left, a column of platelets (height of column 11.4 cm).
Right, original appearance of the headdress.

In addition to these headdresses, Layer 2 contained two rows of flat trapezoidal gilded copper platelets (Fig. 5.30 M16). One was above the other, with 16 platelets in each row (Fig. 5.33). Their size and position suggest that they decorated the hem of a shirt approximately 72 centimeters wide. The central portion of the shirt (Fig. 5.30 M71), which had almost entirely decomposed, appears to have consisted of a textile covered with variously shaped platelets sewn onto it (Fig. 5.34). Only a small portion of these platelets appeared to be in their original position (Fig. 5.35); the others had shifted position as the funerary bundle and its organic contents decomposed. The platelets that were still in their original position appeared to be randomly placed, but they may well have been part of a larger image or pattern.

Nearly all of the platelets that decorated this shirt — the variously shaped platelets covering its central portion, as well as the trapezoidal platelets that decorated the hem — had traces of feathers in their surface corrosion. This suggests that the shirt was made of a feathered textile.

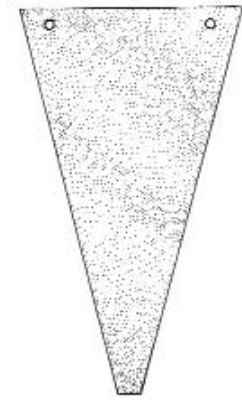

Figure 5.33 A gilded copper platelet from M16 (height 8.5 cm).

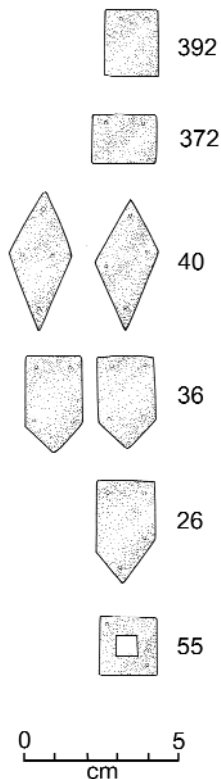

Figure 5.34 The types of platelets in M71, with the number of each that were recovered.

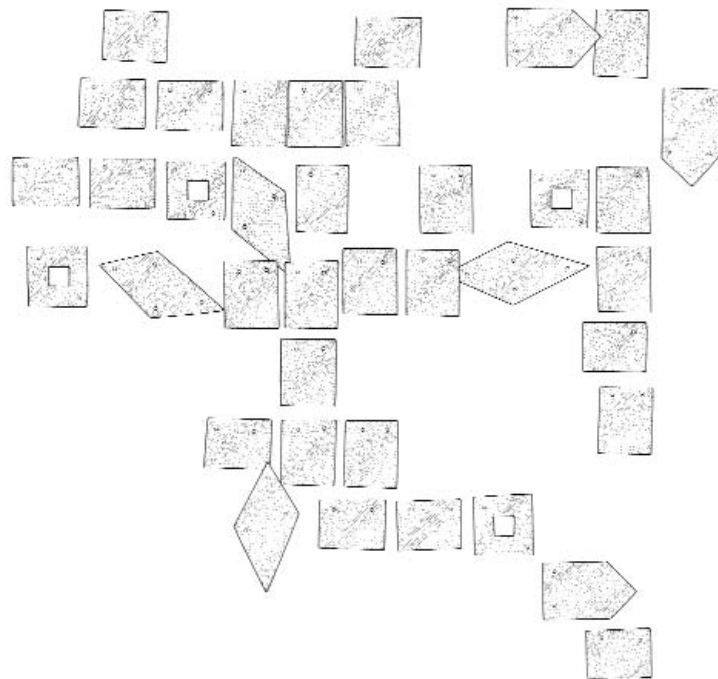

Figure 5.35 The pattern of platelets in M71 that appeared to be in their original position.

LAYER 3

In the third layer of objects within the funerary bundle (Fig. 5.36) there was a headdress consisting of a tall cylindrical sheet of gilded copper with a row of gilded copper discs around its upper and lower edges (Fig. 5.36 M25, Fig. 5.37). It is not clear if it had been attached to the exterior of a basketry cylinder.

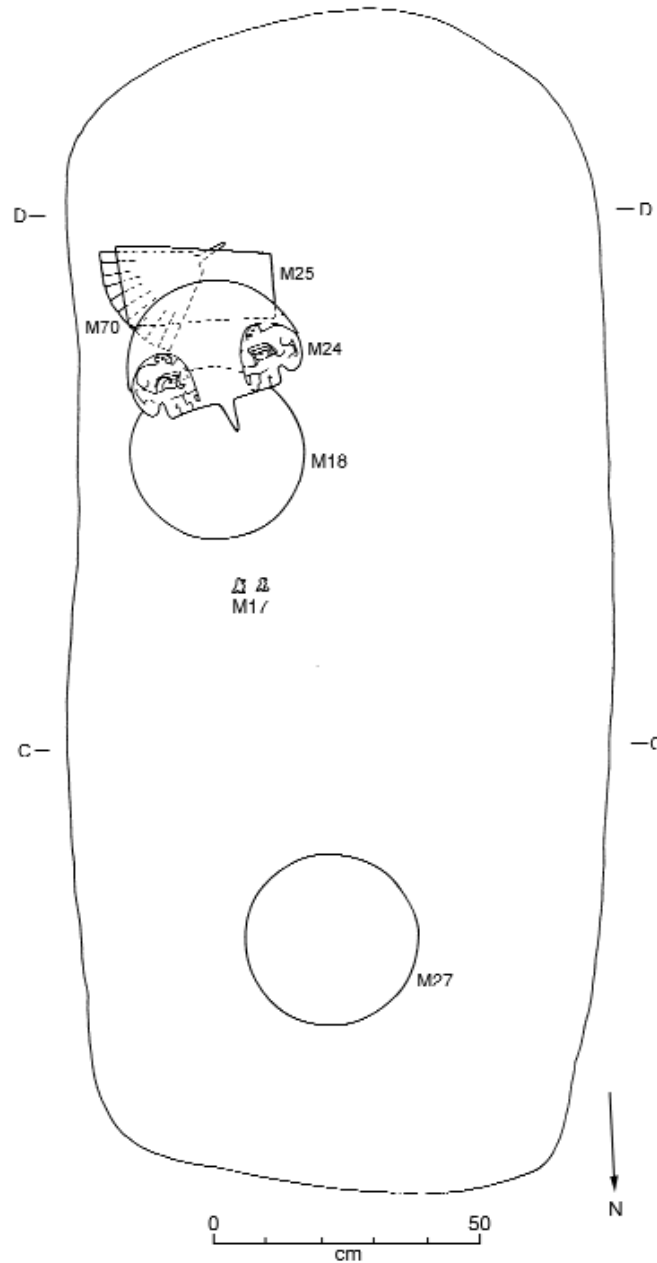

Figure 5.36 Plan of the objects in Layer 3 inside the funerary bundle.

Adjacent to the cylindrical headdress were two gilded copper headdress ornaments. One is a large crescent flanked by male figures with monkeys above their heads (Fig. 5.36 M24, Fig. 5.38). The other is a feather plume of gilded copper (Fig. 5.36 M70) that is nearly identical to the one found directly above it in Layer 1 (Fig. 5.29). These gilded feather plumes may have been used to adorn one or more of the headdresses in this tomb. Because the large crescent-shaped ornament was found between the two shaped like feather plumes, it is also possible that the three may have been used together, with the plumes flanking the crescent the way they are sometimes shown in Moche art (Fig. 5.39).

Also in Layer 3 there were two circular shields covered with platelets of gilded copper (Fig. 5.36 M18, M27). One (Fig. 5.40) has



Figure 5.37 Headdress M25 (height 16.5 cm). Its original appearance.

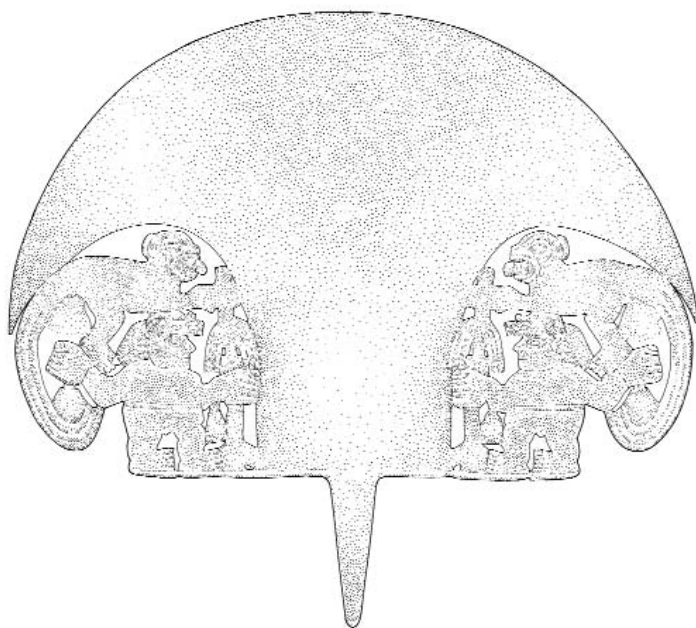

Figure 5.38 Headdress ornament of gilded copper M24 (height 14.7 cm).



Figure 5.39 Moche fineline painting of a warrior wearing a headdress with plumes flanking a crescent-shaped ornament.

rectangular platelets, while the other (Fig. 5.41) has triangular platelets. Although nearly all of the organic material used in their construction had decomposed, it was clear that they were made of a cane framework that was covered with a textile. The gilded copper platelets were then sewn on the textile, covering the front side of the shield.

Positioned between the shields were two small birds made of gilded copper (Fig. 5.36 M17, Fig. 5.42). Although their function is not clear, perforations along their edges suggest that they were to be sewn to a textile.

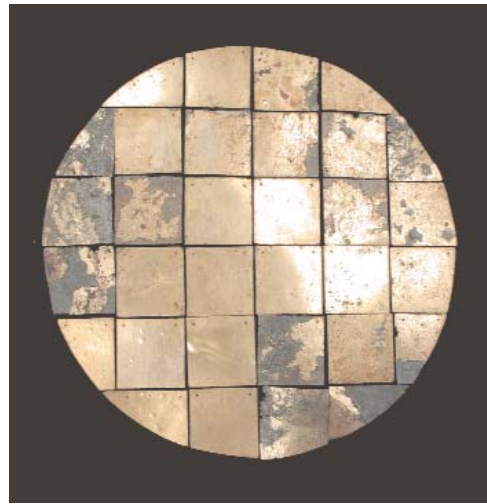
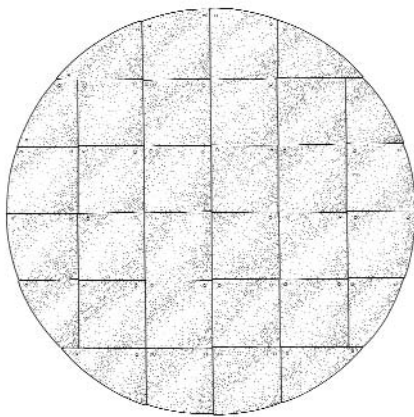

Figure 5.40 Shield with rectangular platelets M18 (diameter 32.3 cm). Right, after cleaning

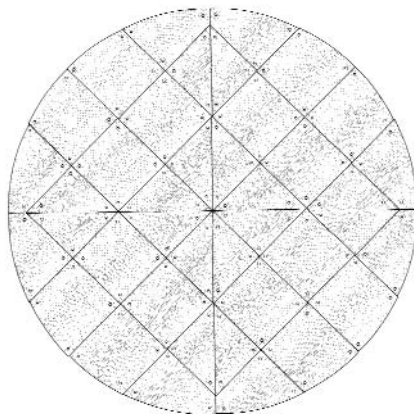

Figure 5.41 Shield with triangular platelets M27 (diameter 32.6 cm).

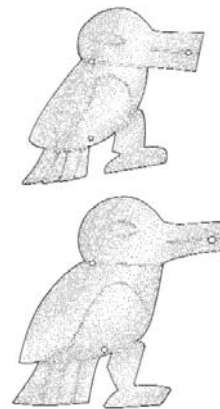

Figure 5.42 Two small gilded copper birds M17 (height of upper 6.6 cm).

LAYER 4

The fourth layer of objects within the funerary bundle (Fig. 5.43) included another cylindrical headdress with three bands of gilded copper (Fig. 5.43

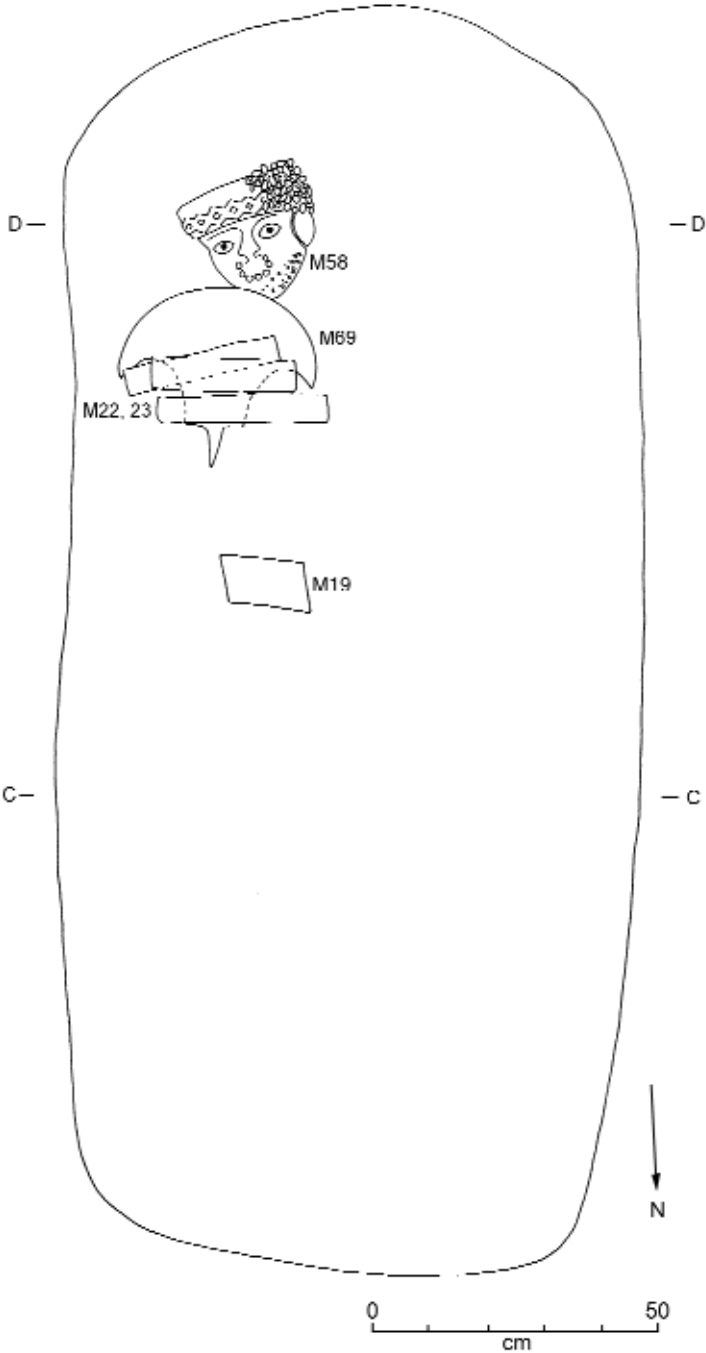

Fig. 5.43 Plan of the objects in Layer 4 inside the funerary bundle.

M22, 23, Figs. 5.44, 5.45). The center band is plain, while the upper and lower bands are decorated with Decapitators similar to those on the banded headdress found in the first layer of objects within the funerary bundle (Figs. 5.25, 5.26). The Decapitators in that headdress, however, are low-relief designs accentuated with cut-out sections. In this headdress the Decapitators are created exclusively in low relief.

Beneath the banded headdress was another crescent-shaped headdress ornament of gilded copper (Fig. 5.43 M69, Fig. 5.46). It is about the same



Figure 5.44 A portion of the band of Headdress M22, 23 after cleaning (height 5.3 cm).

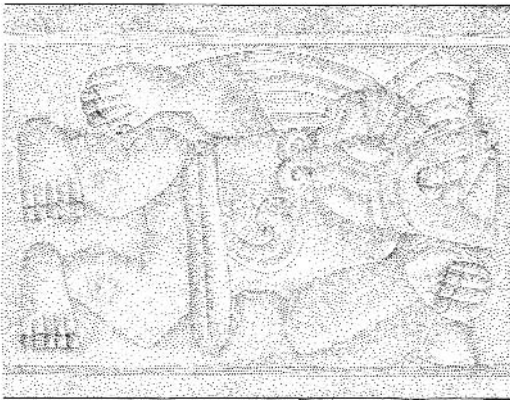

Figure 5.45 Headdress M22, 23. Left, a portion of one of the bands (height 5.3 cm). Right, original appearance of the headdress.

size as the one found in the third layer (Fig. 5.38), but it is not flanked by human figures.

North of this headdress ornament was a group of small rectangular copper platelets (Fig. 5.43 M19). Each platelet was approximately 2 by 2.4 centimeters, and together they covered an area approximately 8 centimeters north-south by 15 centimeters east-west. The function of these platelets is not clear, but they may have been part of a banner similar to those that are sometimes depicted in Moche art (Fig. 5.47).⁸

The individual inside the funerary bundle was an adult male lying on his back in an extended position with his arms at his sides and his head to the south. The large copper bowl found in Layer 1 in the upper part of the funerary bundle (Fig. 5.12 M57, Fig. 5.13) had been turned upside down over his head.

Beneath the bowl, and directly over the face of the individual was a metal burial mask (Fig. 5.43 M58, Figs. 5.48–5.53). Along the upper left side of the mask were numerous small platelets of gilded copper (Figs. 5.48, 5.49) that had originally been attached with wire loops to a textile, possibly a head cloth or turban. As the textile decomposed, the platelets fell out of position and cascaded down around the mask.



Figure 5.48 Burial mask M58 in situ. Note the platelets of gilded copper above and around the upper part of the mask.

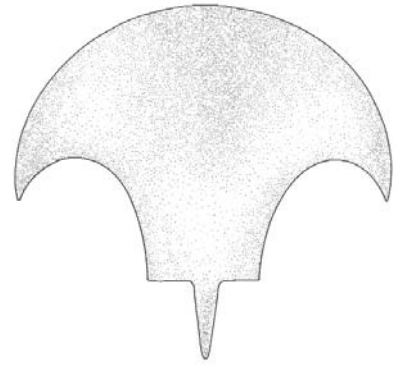

Figure 5.46 Headdress ornament M69 (height 32.4 cm).



Figure 5.47 Moche depiction of a warrior holding a banner in his right hand.

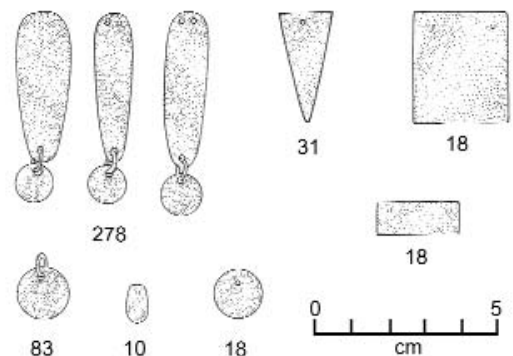

Figure 5.49 The types of gilded copper platelets found adjacent to the mask, with the number of each that were recovered.



Figure 5.50 The burial mask M58 after cleaning (height 27.5 cm).

The mask is almost lifesize and has a gilded copper nose ornament. The eyes are inlaid with white shell and dark violet-colored stones representing the pupils of the eyes. Small discs of gilded copper, each suspended from a wire projecting out from the lower part of the face, appear to represent a beard. A separate band of gilded copper covering the eyebrows and the bridge of the nose is incised with a geometric design of interlocking rays. Across the forehead is another gilded copper band with a repetitive diamond shape, incised with a chevron pattern. Both of these bands are attached with tabs.

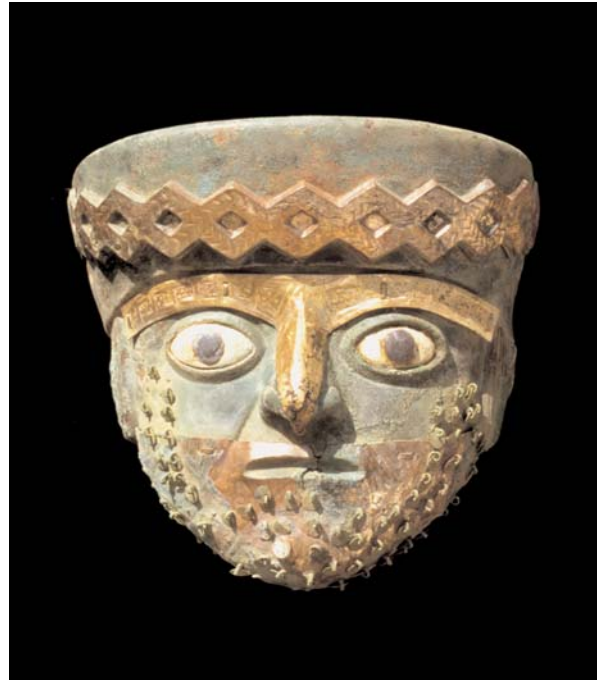

Figure 5.51 Front of the burial mask M58 after cleaning, with the nose ornament removed (height 27.5 cm).



Figure 5.52 Detail of the eye of the burial mask (M58), the staple used to attach the eye band, and the discs suspended from wire loops .



Fig. 5.53 Nose ornament from the burial mask M58 (height 5.4 cm).



Figure 5.54 The face of the individual. There were two ornaments below his nose and one along the left side of his face.

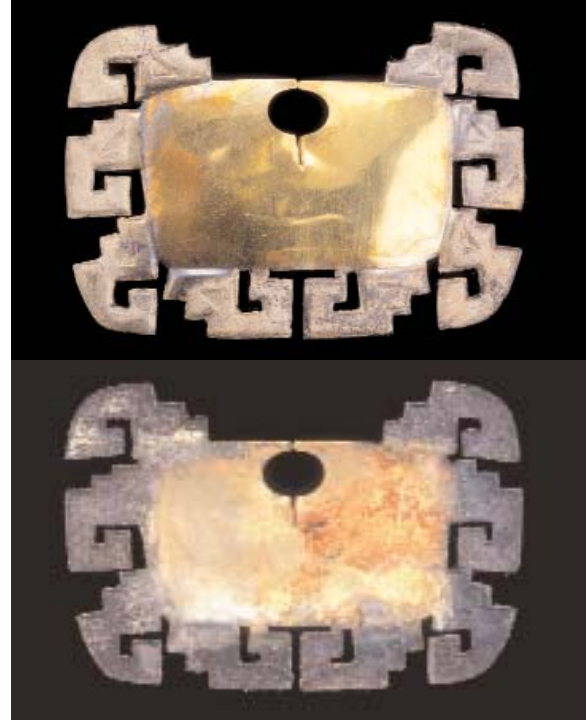

Figure 5.55 Nose ornament that was nearest the individual's face (width 7.5 cm). Above, front after cleaning. Below, back before cleaning, with red pigment.

Immediately beneath the burial mask was the individual's skull, which had been broken by the weight of material above it (Fig. 5.54). There were three ornaments in the area of his mouth (Figs. 5.55–5.57). One was a nose ornament consisting of a semirectangular sheet of gold surrounded by a geometric step design of silver (Fig. 5.55). It was found adjacent to the individual's face and may have been worn by him at the time of burial. Its inside surface had traces of red pigment, as did some of the bones of his face. This suggests that his face was painted red, possibly with cinnabar, when he was buried, and some of the pigment transferred to the inside of the nose ornament as his body decomposed.

The second nose ornament had fallen down along the left side of his face. It is crafted of gold in the form of an X, with a monkey head in the center flanked by Crested Animals (Fig. 5.56). Above the monkey head are two serpents. The left eye of the monkey is inlaid with black stone. The inlay from the right eye is missing.



Figure 5.56 Gold nose ornament with the head of a monkey (width 9 cm).



Figure 5.57 Gold disc with wire loop (diameter 3.8 cm).

The third ornament, which was found over his lower face, was a gold disc with a loop of gold wire (Fig. 5.57). One side of the disc is plated with white gold, giving it a silvery appearance that contrasted with the yellow gold of the other side. It may have been one of a pair of ear ornaments, similar to those frequently depicted in Moche art (Fig. 5.58). Alternatively, it could have been another nose ornament, since there was only one in the tomb, and it was found over the face rather than in the area of the ears. Moreover, a human head looted from the Moche tomb at La Mina (Narvaez 1994) wears a nose ornament consisting of a gold disc suspended from a wire loop (Fig. 5.59).



Figure 5.58 Moche portrait vessel showing an individual wearing disc ear ornaments with wire loops. Not from Dos Cabezas.



Figure 5.59 Moche metal object depicting an individual wearing a disc nose ornament with wire loop. Not from Dos Cabezas.



Figure 5.60 The five gold objects that were in the individual's mouth, as found.

There were five gold objects in the individual's mouth — four nose ornaments and a piece of thin gold foil.⁹ All appear to have been deliberately folded or misshapen (Fig. 5.60). A gold, oval-shaped nose ornament was folded in half. Another gold nose ornament, in the form of an owl head, was compressed inward from the sides and its beak was bent out of position. Two other gold nose ornaments, hinged so the lower part could swing freely, had been dented, and one had a corner bent at a right angle. The piece of gold foil was crumpled into a small lump.

These objects were later cleaned and restored to their original shape. The oval nose ornament (Fig. 5.61) had a slightly concave cross section. The owl nose ornament (Fig. 5.62) consists of flattened bands of gold. The eyes had been inlaid, but only the mastic remained. The beak, which projects forward from the face, is crafted of white gold — thus contrasting subtly with the yellowish gold used to create the rest of the owl's head. The two hinged nose ornaments (Figs. 5.63, 5.64) would have shimmered when worn as the platelets moved and reflected light. The lump of foil had been carefully cut into a long oval shape, with tab-like elements projecting from its ends (Fig. 5.65). Its function remains an enigma.



Figure 5.61 The oval nose ornament, cleaned and unfolded (width 5.6 cm).



Figure 5.62 The owl nose ornament, cleaned and straightened (width 5 cm).

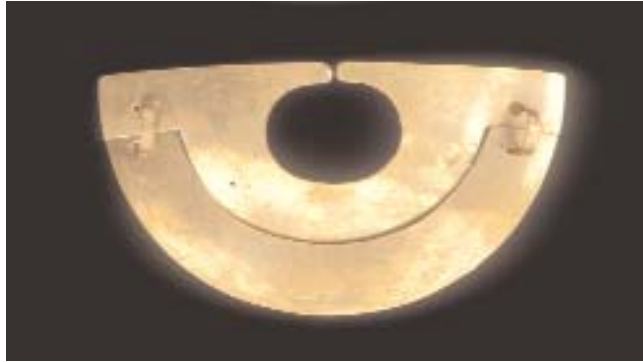

Figure 5.63 The large hinged nose ornament, cleaned and unfolded (width 3.7 cm).

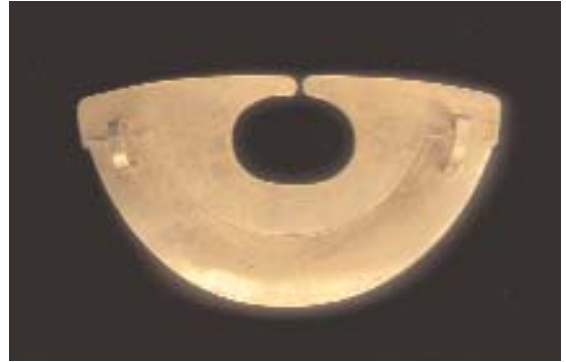

Figure 5.64 The small hinged nose ornament, cleaned and unfolded (width 3.4 cm).



Figure 5.65 The lump of foil, cleaned and unfolded (length 6.5 cm).



Figure 5.66 The individual was buried wearing a quartz crystal necklace and a beaded pectoral.



Figure 5.67 Quartz crystal beads (diameter of largest bead 2.02 cm).

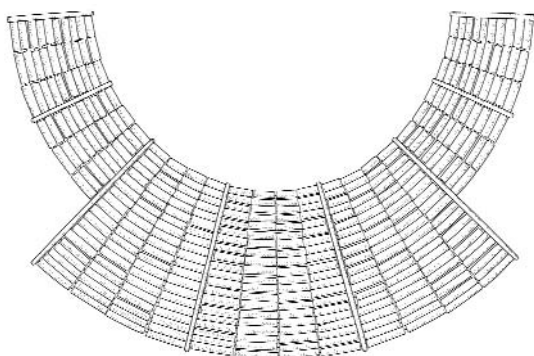

Figure 5.68 The original appearance of the beaded pectoral (height 23.9cm).

At this stage in the excavation, the pieces of the individual's skull were removed and reconstructed and the skull was put back in position so it could be seen in photographs as the excavation continued (Fig. 5.66). The green discoloration on the upper face had been caused by corrosion of the burial mask.

Near the individual's neck there were 40 rock crystal beads from a necklace that he was wearing at the time of burial (Fig. 5.67). Each bead is biconically drilled and polished, so it is transparent. The beads are in graded sizes, varying from 1.16 to 2.02 centimeters in diameter. Some are extremely round, smooth, and well polished while others are less well polished and have somewhat irregular surfaces.

In addition to the rock crystal necklace, the individual was buried wearing a pectoral — a large bib-like ornament that covered the upper part of his chest and shoulders and was tied at the back of the neck. It consisted of white tubular shell beads strung in rows that were kept parallel with spacer bars made of bone (Fig. 5.68). There were two lengths of spacer bars: four short ones (6.2 centimeters long with ten holes) and four long ones (11.6 centimeters long with 20 holes). Although some of the beads and spacer bars had partially decomposed and were not in their original position, the pectoral's original form could be inferred by counting and measuring what remained (Fig. 5.68).

LAYER 5

In the fifth layer of objects inside the funerary bundle (Fig. 5.69) there were small metal hands on each side of the individual's skull (Fig. 5.69 M31E,

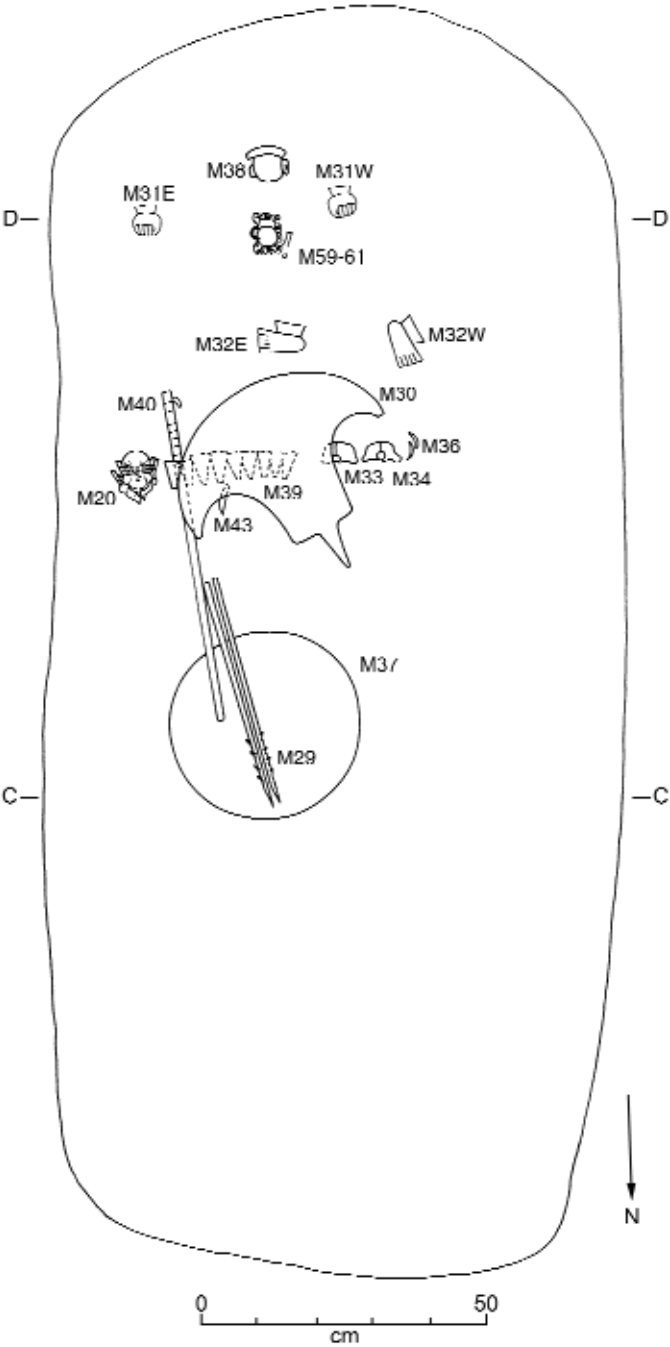

Figure 5.69 Plan of the objects in Layer 5 inside the funerary bundle.

M31W, Fig. 5.70, 5.72) and to the north and northwest of the skull were small metal feet (Figs. 5.69 M32E, M32W, Fig. 5.71). These were made of copper gilded with yellow gold. Their fingernails and toenails, which were made separately and attached with tabs, were made of copper gilded with white gold (Fig. 5.72).

Beneath the individual's neck was a small masklike head of gold and copper, facing down. Its eyes were inlaid with Spondylus shell. Although it was heavily corroded and shattered in many pieces when it was found, much of it was subsequently reconstructed (Fig. 5.73). The head, hands, and feet were probably sewn to a textile or leather panel that was cut in the form of a human with the arms and legs spread (Fig. 5.74). In Moche ceramics, this accessory is sometimes portrayed being worn on the backs of warriors (Fig. 5.75).¹⁰

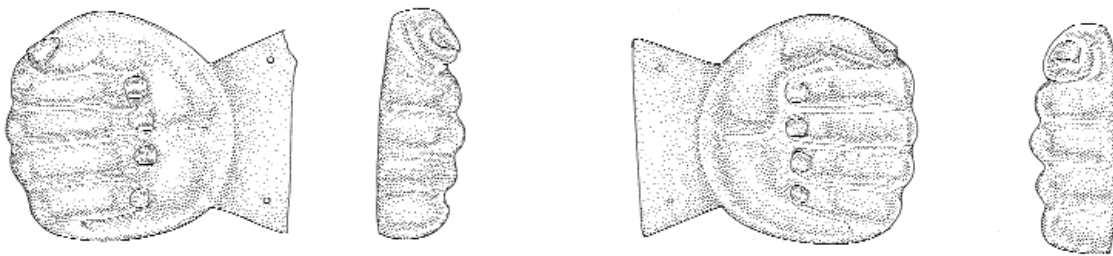

Figure 5.70 Gilded copper hands. Left, M31W (height 5.1 cm). Right, M31E (height 5.2 cm).

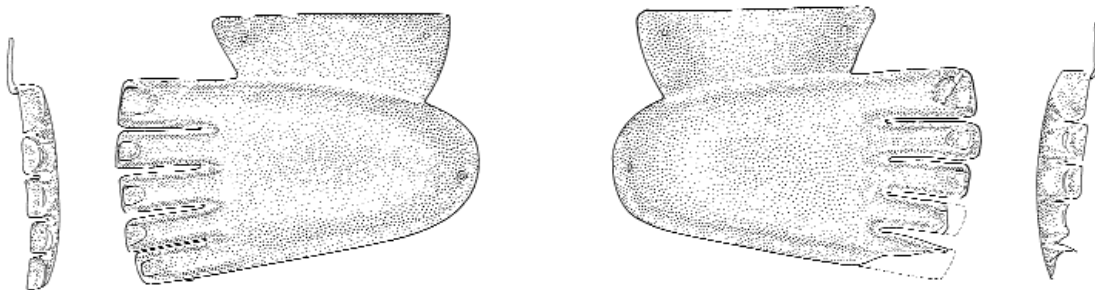

Figure 5.71 Gilded copper feet. Left, M32E (height 5.4 cm). Right, M32W (height 5.4 cm).



Figure 5.72 Gilded copper hand after cleaning M31W (height 6.2 cm). Left, exterior. Right, interior. Note the attachment of the fingernails, with tabs inserted from the exterior and spread on the interior.

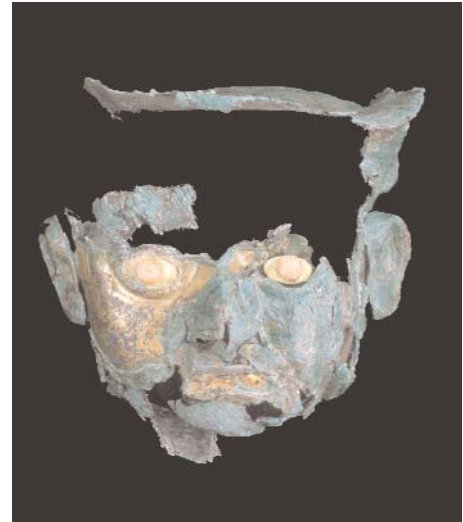

Figure 5.73 Head with Spondylus eyes M38 (height 9.5 cm).

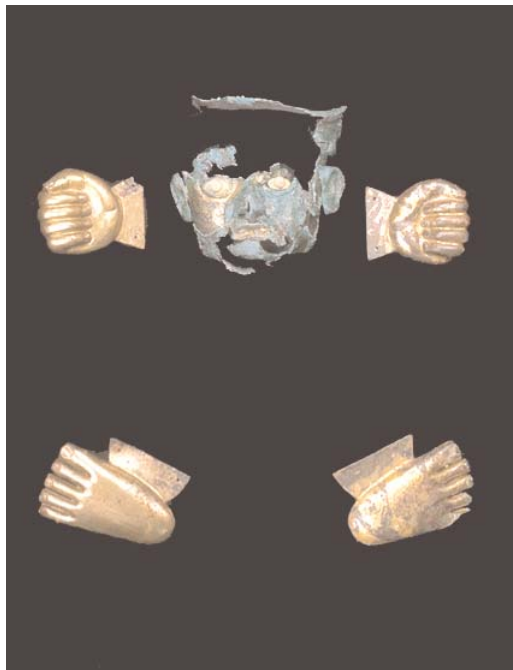

Figure 5.74 The hands, feet, and head combined to form an accessory worn on the back, as shown in Fig. 5.75.

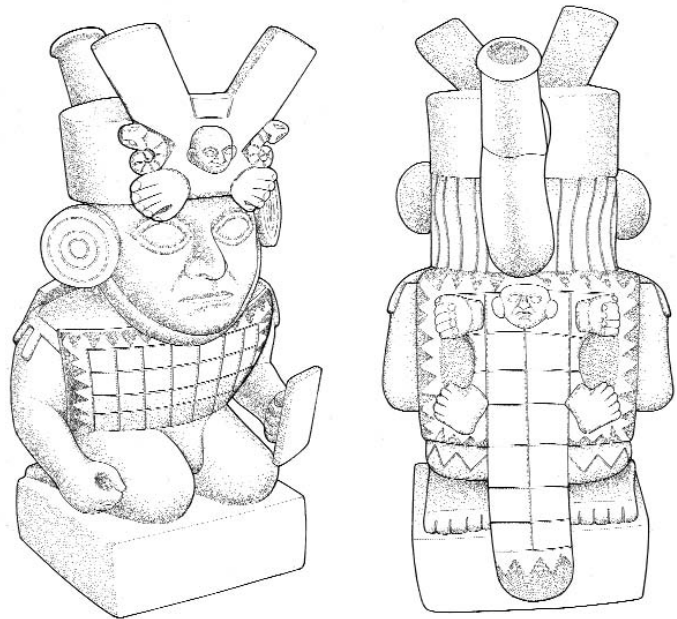

Figure 5.75 Drawing of a Moche ceramic vessel depicting a warrior wearing an accessory on his back that combines hands, feet, and a head.



Figure 5.76 Large crescent-shaped headdress ornament M39 in situ.

Over the individual's lower torso was another crescent-shaped headdress ornament (Fig. 5.69 M43, Figs. 5.76, 5.77). It was similar to the one in the level above but was considerably larger. Moreover, one half was made of copper gilded with yellow gold and the other of copper gilded with white gold. They were joined with tabs on one half that were inserted into slits on the other half. The Moche frequently paired gold and silver, which appears to have had a symbolic meaning. It almost always involved exhibiting gold on the proper right side of the individual and silver on the proper left side, just as was found in the funerary bundle.¹¹

On the western edge of this headdress ornament were three more nose ornaments (Fig. 5.69 M36, M33, M34.). One, which was made of silver, was broken in two, apparently by having been folded and opened repeatedly (Fig. 5.78). It is very similar in size and form to the oval gold nose ornament that had been folded in half and placed in the individual's mouth (Fig. 5.61). The other two nose ornaments are nearly identical to one another. One half is gold and the other half silver, with a lizard depicted in low relief on each half (Fig. 5.69 M34, Fig. 5.79). The eyes of the lizards are inlaid with black stone. These nose ornaments exhibit no evidence of folding or denting, but the silver portion of each is heavily corroded and partially missing.



Figure 5.77 Large crescent-shaped headdress ornament M39 after cleaning (height 37 cm).



Figure 5.78 Silver nose ornament M36 after cleaning and joining the two halves (height 5.8 cm).

Beneath the eastern edge of the crescent-shaped headdress ornament was a gold nose ornament in the form of a bat (Fig. 5.69 M43, Fig. 5.80). When found, the left foot was folded back underneath. It could not be determined whether it had been bent deliberately.



Figure 5.79 One of two lizard nose ornaments of gold and silver M33 after cleaning (width 7 cm).



Figure 5.80 Bat nose ornament of gold M43 after cleaning (width 9.3 cm).

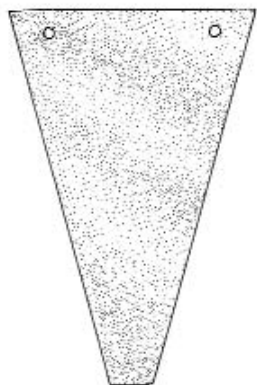

Figure 5.81 One of the trapezoidal platelets of gilded copper M39 (height 7.9 cm).



Figure 5.82 Moche painting of a warrior wearing a conical helmet with triangular elements on the chinstrap.

Beneath the east side of the crescent-shaped headdress ornament there was a line of trapezoidal platelets of gilded copper (Fig. 5.69 M39, Fig. 5.81). These are similar to the ones in Layer 2 that ornamented the hem of a shirt (Fig. 5.33), but they are smaller and there were fewer of them. Although they may have ornamented the hem of a smaller shirt, it is also possible that they were attached to the chin strap of a helmet. Similar chin straps are frequent-

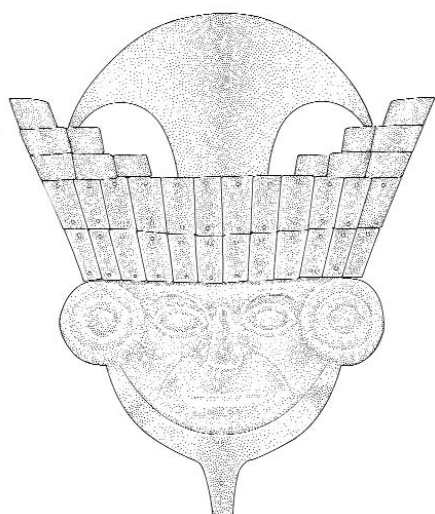

Figure 5.83 Headdress ornament M20 (height 16.5 cm).

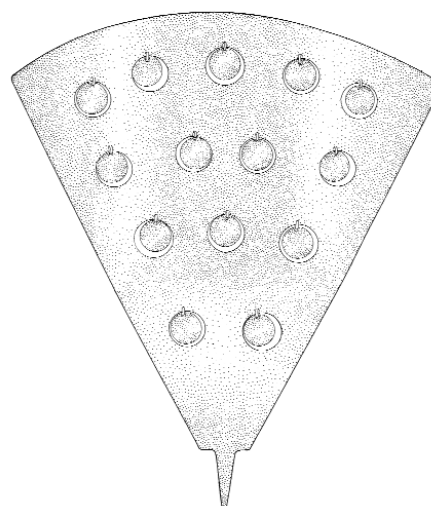

Figure 5.84 Headdress ornament M20 (height 16.2 cm).

ly portrayed in Moche art (Fig. 5.82).

Immediately east of the trapezoidal platelets was a stack of eight plumelike objects of gilded copper (Fig. 5.69 M20). Four were in the form of human heads wearing ear ornaments and elaborate headdresses (Fig. 5.83), while the other four were triangular, with discs suspended inside circular cutouts (Fig. 5.84). Both types are probably headdress ornaments and may have been used to adorn the headdresses in this tomb.

Beneath the east edge of the large crescent-shaped headdress ornament was a spear thrower (Fig. 5.69 M40, Figs. 5.85–5.87). The upper end of the spear thrower was capped with gilded copper, and the shaft was further elaborated with bands of gilded copper. Its engaging spur was cast in the form of a lizard, whose eyes were inlaid with black stones (Fig. 5.87).

The lower end of the spear thrower was resting on another shield (Fig. 5.69 M37). The front of this shield was covered with small gilded copper platelets. Although many of the platelets had completely decomposed from corrosion, it was possible to reconstruct the shield's original size and form (Fig. 5.88).



Figure 5.85 The central and upper part of the individual's body. Note the spear thrower along the right arm and the shield over the upper legs, with two copper spear points resting on top of it.

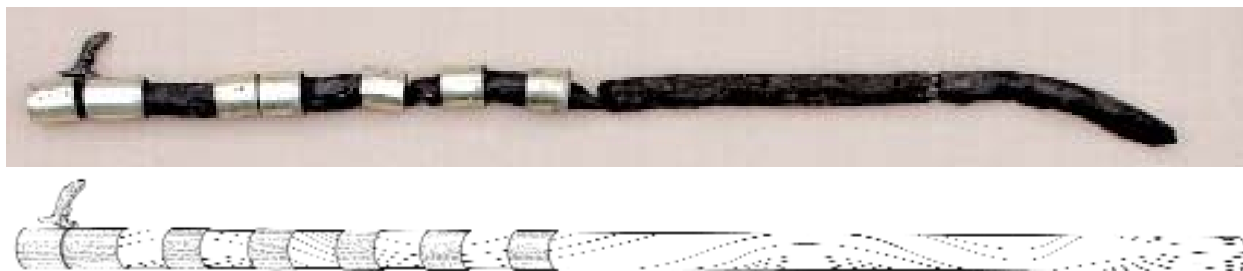

Figure 5.86 Spear thrower M40. Upper, after cleaning. Lower, its original appearance (length 49.2 cm).

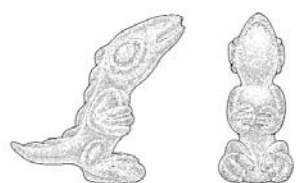

Figure 5.87 Engaging spur of spear thrower M40 (height 8.2 cm).

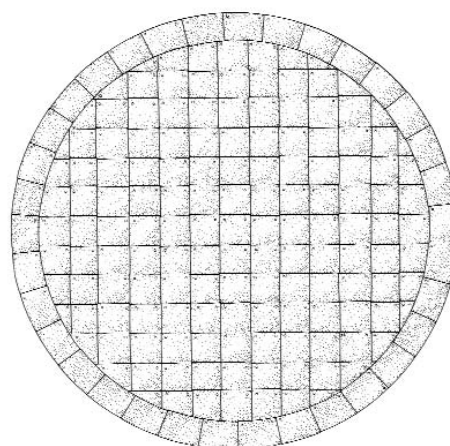

Figure 5.88 Shield M37 (diameter 30 cm).

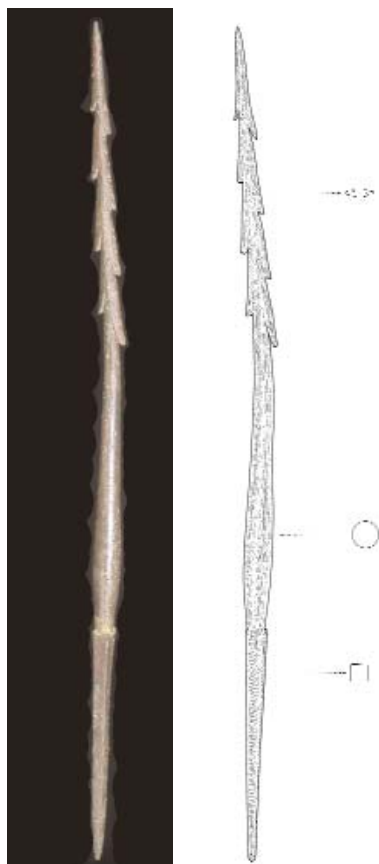

Figure 5.89 One of the barbed spear points M29 (height 32.5 cm). Left, after cleaning. Right, drawn with cross sections.

Two barbed copper spear points were also lying on the shield (Fig. 5.69 M29, Figs. 5.85, 5.89). One end of these points showed evidence of having been wrapped with string, probably to facilitate being socketed into a length of cane that would have served as the spear shaft.

When the objects in Layer 5 were removed, the skeleton of the deceased could be fully exposed (Fig. 5.90). He was an adult male between 18 and 20 years of age. His height is estimated to have been 181 centimeters — even taller than the individual in Tomb A, and clearly another individual of great stature compared to most Moche males. There were no indications of the cause of death. There was also no evidence that he was wearing garments, foot coverings, or head coverings at the time of burial, but these could have been made of organic materials that decomposed.



Figure 5.90 The individual with a war club and a scepter along the inside of his right arm and three tumi knives over his torso.

LAYER 6

In the individual's right hand were four small metal chisels (Figs. 5.92 M44, Fig. 5.93a-d), and in his left hand was another metal chisel (Fig. 5.92 M52,

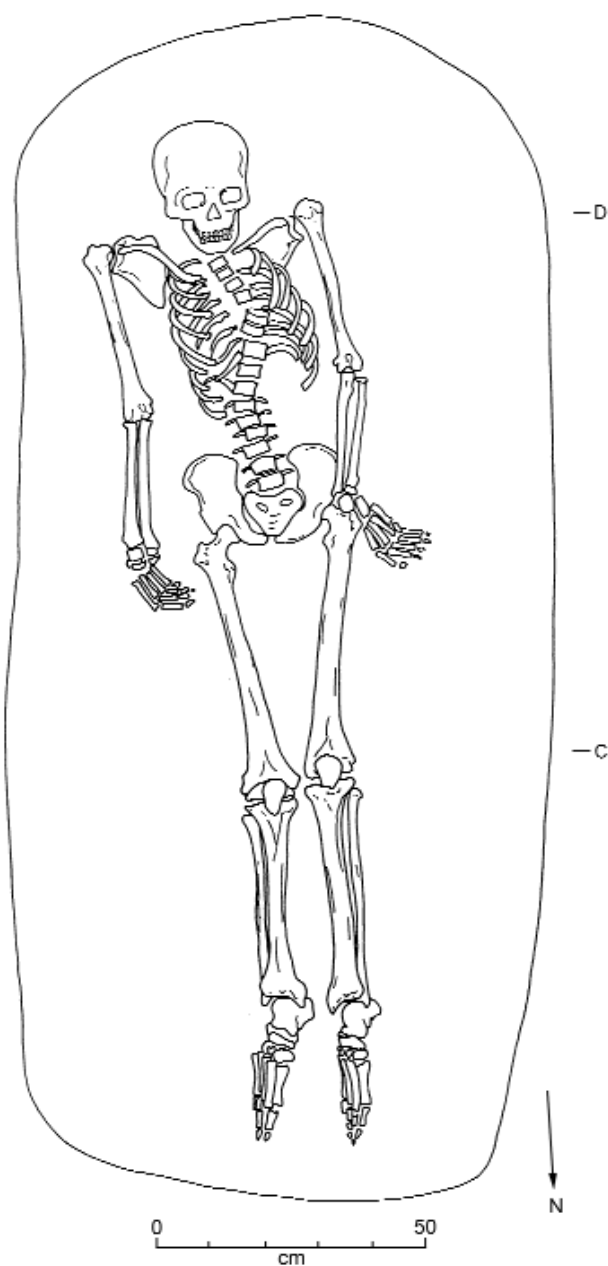

Figure 5.91 Plan of the skeleton in Layer 6 inside the funerary bundle.

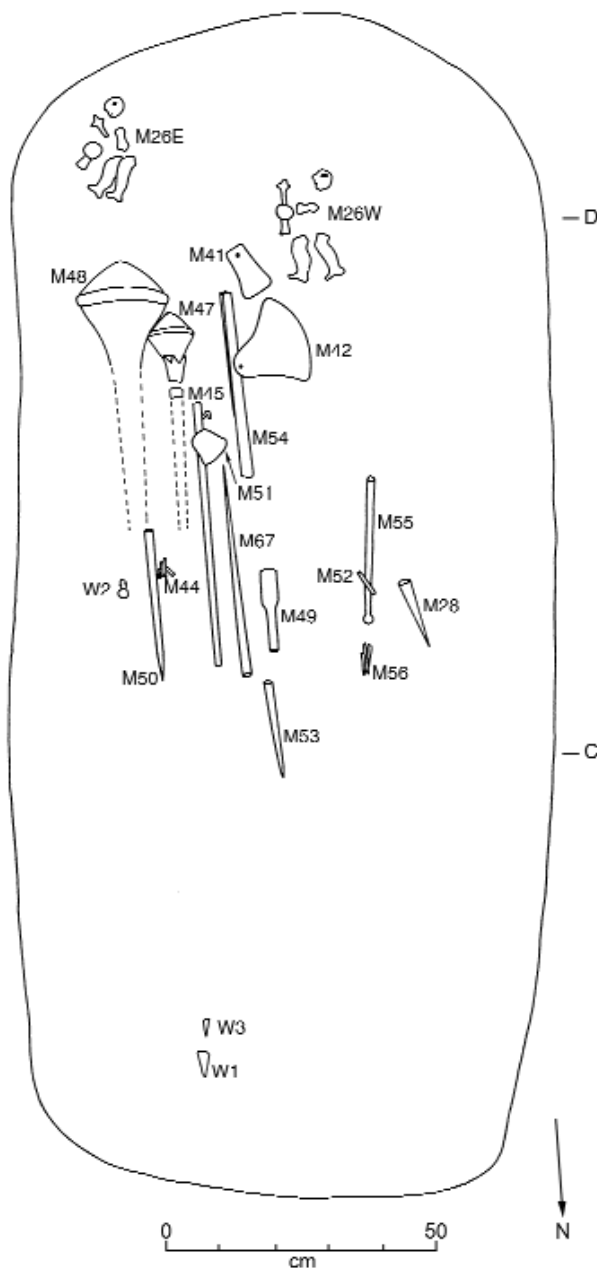

Figure 5.92 Plan of the objects in Layer 6 inside the funerary bundle.

Fig.5.93e).¹² The four in his right hand are almost pure copper (more than 98%), while the one in his left hand is an alloy of approximately 52% copper, 29% gold, 18% silver, and 2% arsenic. These chisels are of a size and form that could have been used in working sheet metal — cutting, incising, or creating low-relief décor. No chisels have ever before been excavated in the hands in Moche burials. Why they were in his hands, what they signified, and whether they were his or belonged to someone else are questions that cannot be answered on the basis of available information.

Southeast of the individual's skull was a small human figure, portrayed in profile (Fig. 5.92 M26E), and a mirror image of this figure was found northwest of the skull (Fig. 5.92 M26W). Each figure consists of two legs, one arm, a head, a club, and a shield (Fig. 5.94). The lower face and chin of each head are recessed, and a series of holes around the depressed portion suggests that something was attached there. It may have been something of perishable material, possibly representing a beard. The function of these metal figures is not clear, but each of their metal parts is perforated at the edge, suggesting that they were to be sewn to a textile. Strangely, their torsos and headdresses are missing; perhaps they were made of perishable material.

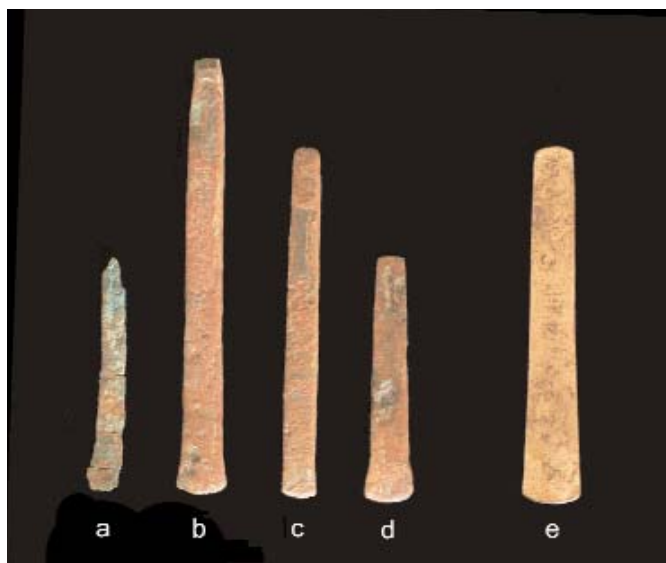

Figure 5.93 Small chisels. a-d. M44 in right hand. e. M52 in left hand (height of longest chisel 12.7 cm).



Figure 5.94 Small human figures. Left, M26E. Right, M26W (height 17.4 cm).

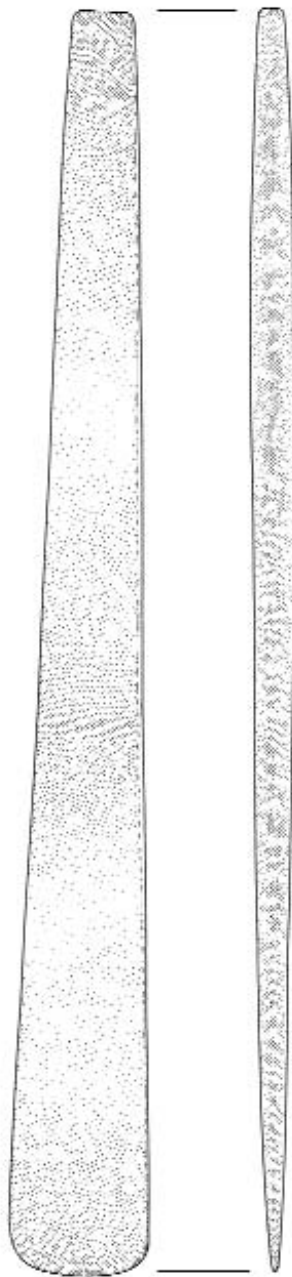

Figure 5.96 Chisel M54 (height 44.2 cm).



Figure 5.95 Tumis a. M51 (height 6 cm). b. M41 (height 9.5 cm). c. M42 (height 15 cm).

Beneath the individual's torso were three tumis (Fig. 5.92 M41, M42, M51). All three were made of copper, but each was unique in size and form (Fig. 5.95). They all had a hole at the upper part of the handle through which a cord would have been strung. The upper end of one tumi was on top of a large copper chisel (Fig. 5.92 M54, Fig. 5.96).¹³

Beneath the individual's upper right leg and pelvis was another spear thrower (Fig. 5.92 M45, Fig. 5.97). It was much simpler than the one in Layer 5 (Fig. 5.86). Its engaging spur was a plain hook (Fig. 5.98), and there were no gilded copper elements elaborating its wood shaft.

Parallel to this spear thrower and slightly to the west was the longest of four metal points (Fig. 5.92 M67, Fig. 5.99b). The second longest point (Fig. 5.92 M50, Fig. 5.99c) was beneath the individual's right wrist. The third longest (Fig. 5.92 M53, Fig. 5.99a) was beneath his lower right femur, and the shortest (Fig. 5.92 M28, Fig. 5.99c) was near his left hand. All four points have deep sockets in their bases to facilitate hafting to wooden shafts. Wood residue was found in the socket of each, but beyond the base of the points the wood had completely decomposed. Although the length of the wooden



Figure 5.97 Spear thrower M45 (length 51.2 cm).

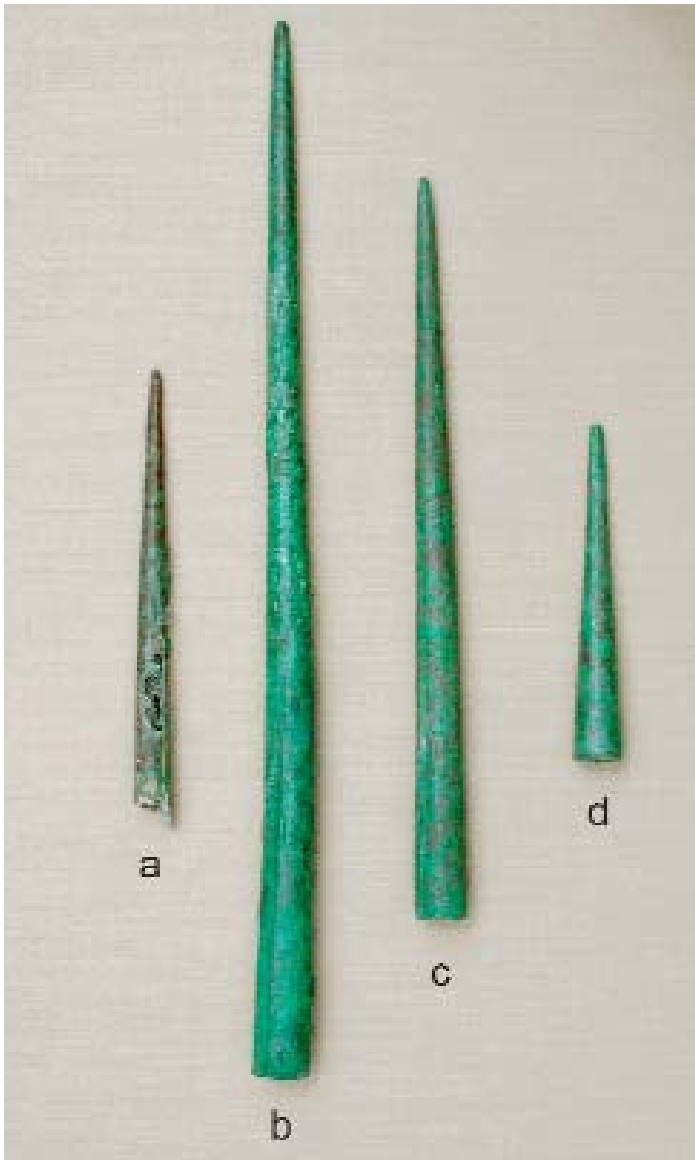

Figure 5.99 Spear points. a M53 (length 18.2 cm). b M67 (length 39.6 cm). c M50 (length 28 cm). d M28 (length 12.4 cm).

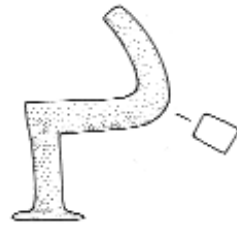

Figure 5.98 Engaging spur of spear thrower M45 (height 3.5 cm).

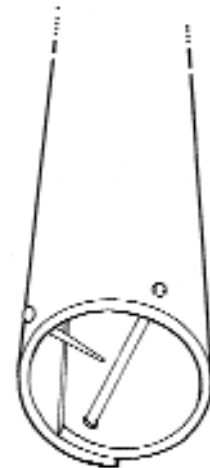
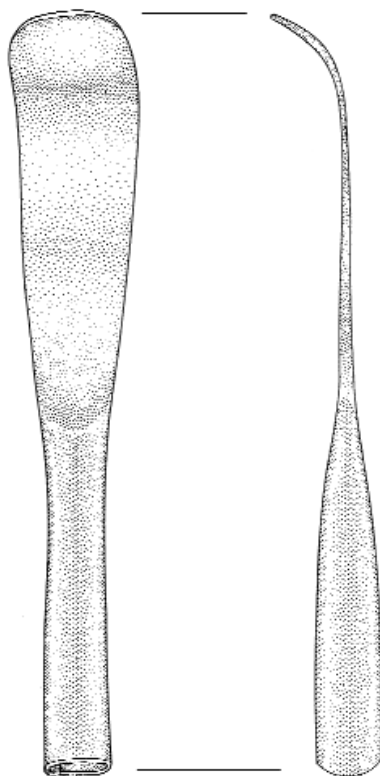

Figure 5.100 Detail of the base of the spears showing the use of nails and rivets for attachment to the wood shaft.

shafts could not be determined, it is likely that they were long and that the implements were spears with copper points. The points were attached to the wooden shafts with nails and/or rivets (Fig. 5.100).

Two other objects also had deep sockets at their bases and contained residue of decomposed wood held in place with nails or rivets. One, which was between the individual's legs, had a curved, spatula-like blade (Fig. 5.92 M49, Fig. 5.101). The other, which was beneath the left hand, had a solid sphere at one end (Fig. 5.92 M55, Fig. 5.102). Unfortunately, because the handles had decomposed, it was impossible to determine their original length. Nothing like these implements has been found in excavations nor identified in Moche art, and their functions remain an enigma.

Under the right shoulder were the remains of a large war club (Fig. 5.92 M48), identical to those depicted in Moche art (Figs. 5.39, 5.82). It appeared to have been carved from a single piece of wood, and had a band of copper



*Figure 5.101 Curved spatula
M49. (height 15.2 cm.)*



*Figure 5.102 Shaft with solid
sphere M55. (height 18.9 cm.)*

around the equator of the club head. Unfortunately, most of the wood had decomposed, and thus it was not possible to determine its original length. Adjacent to it was what appeared to be a smaller war club (Fig. 5.92 M47). It had decorative bands of gilded copper around the shaft (Figs. 5.103, 5.104). The copper portion that looks like a club head is hollow and contains three hollow copper spheres that would have rattled when the implement was shaken. Perhaps it is a scepter or a symbolic war club for ceremonial use. Its lower end had entirely decomposed and thus it was not possible to determine its original length.

There was a cluster of small rectangular metal objects west of the individual's left leg (Fig. 5.92 M56) and two small pieces of wood east of his right foot (Fig. 5.92 W1, W3). These were parts of objects whose function could not be determined, although one



Figure 5.103 The upper parts of the scepter in the form of a war club M47.

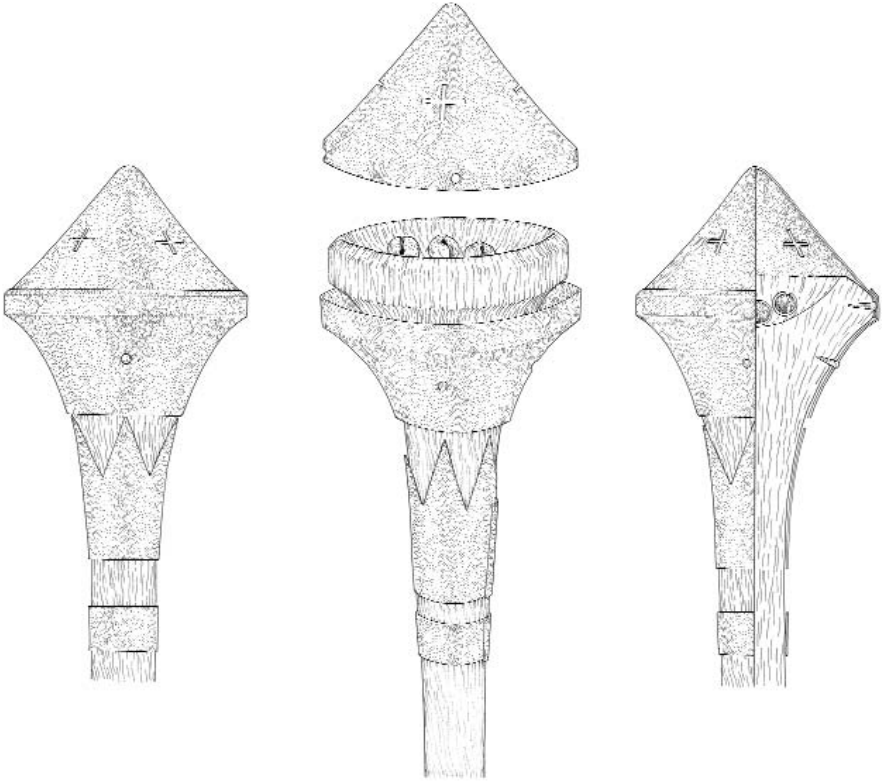

Figure 5.104 Assembly of the scepter in the form of a war club M47. Note how the upper portion of copper fits over the wooden portion to encase metal spheres, thus creating a rattle (height of copper portion when top and bottom are joined 9.4 cm).

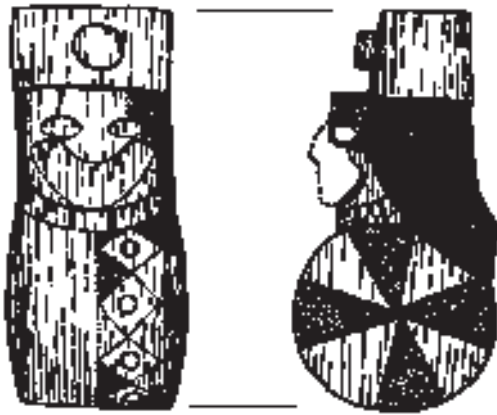

Figure 5.105 Wood and clay object depicting a head on a drum-shaped base W2 (height 5.2 cm).



Figure 5.106 Moche ceramic vessel depicting a head on a drum-shaped base. Not from Dos Cabezas.

of the wood pieces (Fig. 5.92 W1) may be the pointed end of the war club (Fig. 5.92 M48) and the other (Fig. 5.92 W3) may be the pointed end of the scepter (Fig. 5.92 M47).

West of his right hand was a small piece of carved wood depicting a head on a drum-shaped base (Fig. 5.92 W2, Fig. 5.105). The hair was created with a gray clay-like material. Moche ceramics sometimes depict a human head on top of a drum (Fig. 5.106), but what it symbolizes is not known.

Unfortunately, the numerous textiles that had been wrapped around the individual's body, forming the large funerary bundle, had decomposed into a thick mass of brown, black, red, and gray powder. In only a few instances, where they were adjacent to copper objects, were any traces of them preserved. These are enough, however, to demonstrate that the textiles were very elaborate and colorful, utilizing both wool and cotton yarns in complex weaves. It is likely that many of the textiles carried elaborate iconography.

There were two kinds of plant remains inside the funerary bundle: espingo seeds (*Nectandra* sp.) and ulluchus. Espingo seeds are frequently depicted in Moche art, where they appear to be drilled and strung on long cords. They are still sold this way in herb markets on the north coast of Peru. They have a strong and distinct odor and are used by folk healers to treat a variety of symptoms (Montoya 1999). All of the espingo seeds found in Tomb 2 were

perforated (Fig. 5.107).

Ulluchus are also frequently depicted in Moche art, but they are not used in contemporary folk healing and are not available in modern Peruvian herb markets (Fig. 5.108). In fact, although extensive effort has been made to identify the plant from which they come, it still remains an enigma (McClelland, ms.). Their presence in Tomb 2 is very unusual, for they have only been excavated in one other Moche context — in a royal tomb at Sipán, where they were sewn onto banners beneath gilded copper platelets that had been embossed to depict ulluchus (Alva and Donnan 1993:189; Alva 1994:184).

The espingo seeds and ulluchus were found scattered within the funerary bundle. Many may have moved from their original position as the textiles decomposed. Most were found adjacent to the body of the deceased, and their locations were recorded accordingly (Fig. 5.109). Others were found beneath the small metal hands and feet of the human-like object worn over the individual's back (Fig. 5.74). Perhaps they had been placed between the metal hands and feet and the panel on which they were sewn. It is also possible, however, that their location beneath the hand and feet was spurious — no botanical remains were noted beneath one of the metal feet (Fig. 5.71 M32E).



Figure 5.107 Two of the espingos excavated in Tomb 2. Exterior above, interior below (length of the one below 2.3 cm).



Figure 5.108 One of the ulluchus excavated in Tomb 2 (length 2.9 cm).

Location	Espingo	Ulluchu
Adjacent to the body		
Inner side of upper right arm	1	
Above right elbow		5
At tip of left hand		4 (possibly 5)
West side of lower right arm	2	7
Chest area	18	
Adjacent to objects		
Under west metal hand (M31W)		1
Under east metal hand (M31E)		2
Under west metal foot (M32W)	1 (possibly 2)	1

Figure 5.109 The location of espingos and ulluchus inside the funerary bundle.

OUTSIDE THE FUNERARY BUNDLE

Outside the funerary bundle there were numerous objects on the tomb floor (Figs. 5.8, 5.9). In the southeast corner (Fig. 5.110) a llama skull, a parrot skeleton, five ofrendas (C25-C29), and three stirrup spout bottles (C15-C17) were recovered. One of the latter (Fig. 5.110 C17) portrays a seated figure wearing a cylindrical headdress with an elaborate frontlet consisting of octopus tentacles and an owl head (Fig. 5.111). The cylindrical headdress is similar in appearance to one found inside the funerary bundle in this tomb (Fig. 5.26). He also wears bracelets and a necklace of large beads in the form of animal heads.¹⁴

The other two stirrup spout bottles portray the Crested Animal. One (Fig. 5.110 C15) has four legs (Fig. 5.112); the other (Fig. 5.110 C16) has two front legs and the lower body like that of a seahorse (Fig. 5.113). Both vessels were damaged before they were placed in the tomb, and portions of them were missing.

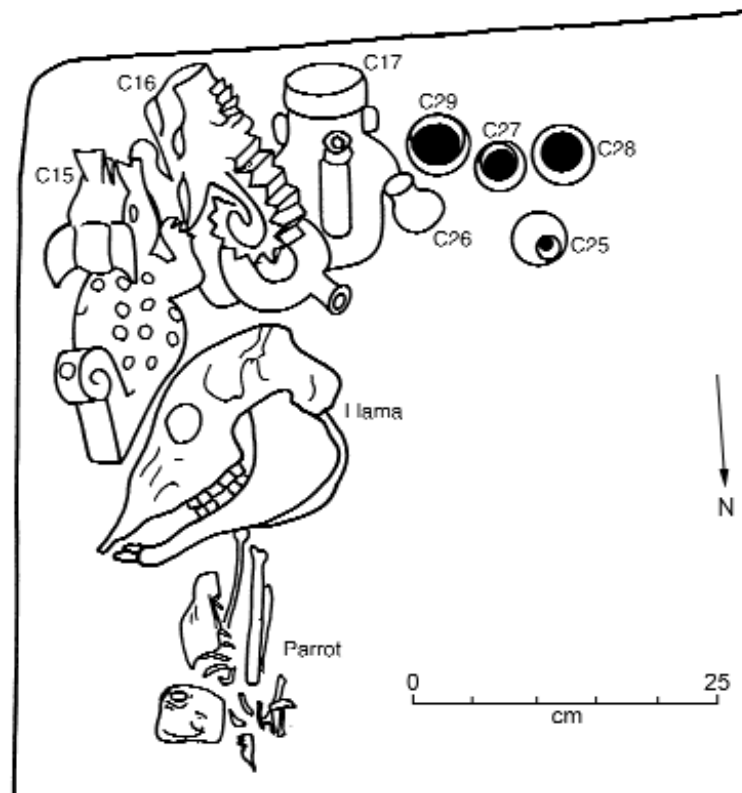

Figure 5.110 Objects in the southeast corner of the burial chamber.



Figure 5.111 Seated figure C17. Left, oblique view. Right, top view (height 20 cm).



Figure 5.112 Crested Animal with four legs C15 (height 20 cm).



Figure 5.113 Crested Animal with a lower body like that of a seahorse C16 (height 17.4 cm).

In the southwest corner of the burial chamber there were ten ceramic vessels, four of which were ofrendas (Figs. 5.114-C10, C12–C14). The other six consisted of three jars, one olla, and two stirrup spout bottles (Fig. 5.114 C1–C5, C11). One of the jars (Fig. 5.115) was small — about the size of an ofrenda but well made and slip painted with a white-on-red geometric design. The other two jars were well made and slip painted (Figs. 5.116, 5.117). The

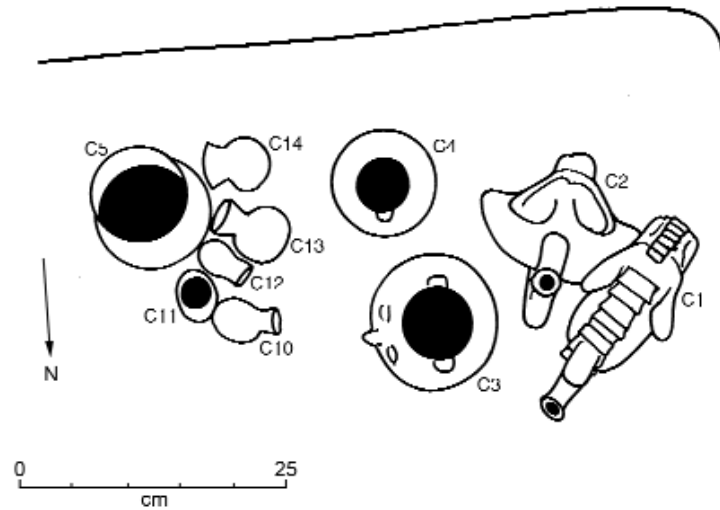

Figure 5.114 Objects in the southwest corner of the burial chamber.



Figure 5.115 Miniature jar C11 (height 6.9 cm).



Figure 5.116 Jar C4 (height 13.5 cm).



Figure 5.117 Jar C5 (height 15.3 cm).



Figure 5.118 Olla C3 (height 14.2 cm).



Figure 5.119 Bat C2 (height 18.2 cm).



Figure 5.120 Crested Animal with the lower body like that of a seahorse C1 (height 20 cm).

olla, which was made of coarse clay and was not slip painted, had an owl face depicted on its chamber (Fig. 5.118).¹⁵

One of the stirrup spout bottles in the tomb's southwest corner depicts a bat (Fig. 5.114 C2, Fig. 5.119). Though made of white clay, red slip paint accentuates the nose, the hooks on the wings, and the narrow tongue that extends along the floor of the bat's open mouth. Its upper left fang had broken off before it was placed in the tomb. The other stirrup spout bottle portrays the Crested Animal (Fig. 5.114 C1, Fig. 5.120). It is nearly identical to

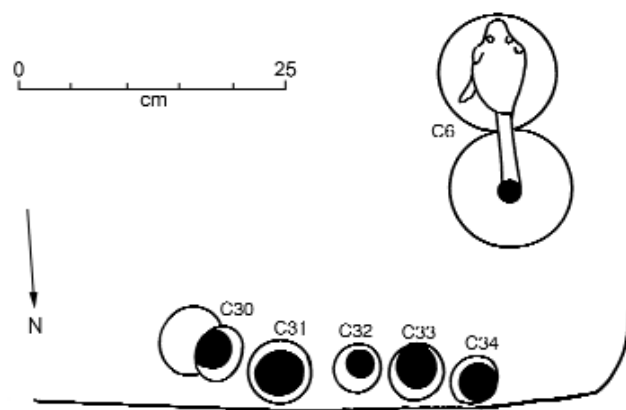

Figure 5.121 Objects in the northwest corner of the burial chamber.



Figure 5.122 Double chambered whistling bottle with sea lion C6 (height 15.6 cm).

the one with a seahorse body found in the tomb's southeast corner (Fig. 5.113) and may have been made by the same potter. This bottle, however, was complete when it was placed in the tomb.

In the northwest corner of the burial chamber there were five ofrendas (Fig. 5.12 C30–C34) and a double-chambered whistling bottle with a sea lion sculpted on one of the chambers (Fig. 5.121 C6, Fig. 5.122).

Finally, in the northeast corner of the burial chamber were six ofrendas (Fig. 5.123 C9, C20–C24), two dippers, and two stirrup spout bottles. The

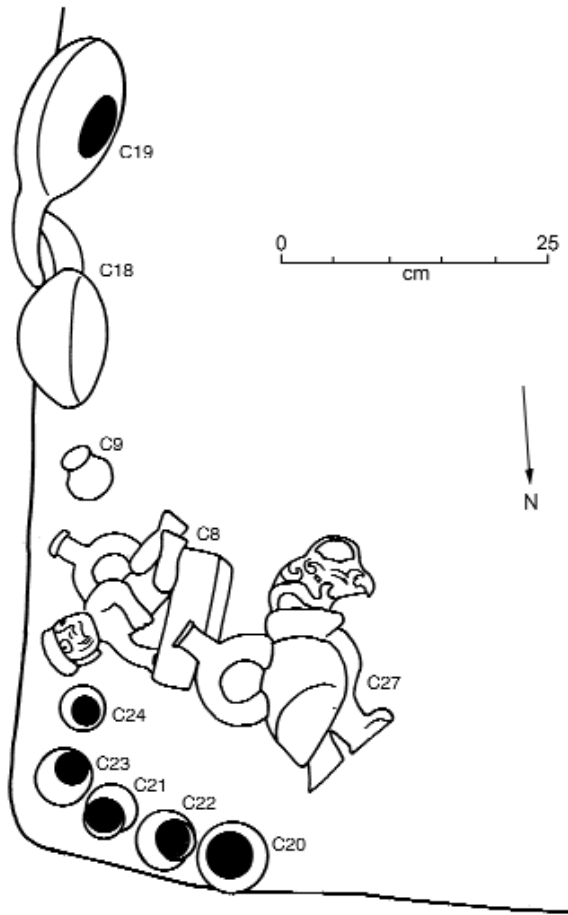

Figure 5.123 Objects in the northeast corner of the burial chamber.



Figure 5.124 Blackware dipper C18 (length 22 cm).



Figure 5.125 Redware dipper C19 (length 26.5 cm).

dippers, one of which was blackware (Fig. 5.123 C18, Fig. 5.124) and the other redware (Fig. 5.123 C19, Fig. 5.125), were leaning against the east side of the tomb chamber with their handles crossed.

One of the stirrup spout bottles (Fig. 5.112 C27, Fig. 5.126) depicts a condor. The other (Fig. 5.123 C8, Fig. 5.127) depicts a nude male lying on his side, supporting himself with his right arm. His face, with inlaid shell eyes, is vertically divided in half — the left half is normal, while the right half is contorted. Beneath his torso is a shallow container with round objects.¹⁶ The shell inlay depicting the left pupil was missing when this bottle was placed in the tomb, but otherwise the vessel is intact.

There were five other objects on the floor of the tomb. One, located near



Figure 5.126 Condor C27 (height 20.1 cm).



Figure 5.127 Reclining figure C8 (height 18.7 cm).

the center of the north wall, was a parrot skeleton (Fig. 5.9). The other three, located near the center of the south wall, were fragments of a stirrup spout bottle (Figs. 5.9, 5.128). All three fragments had the same paste, color, and texture and thus were almost certainly from the same vessel. They are nearly identical to portions of the Crested Animal in Figure 5.112, which was found in the southeast corner of the burial chamber. The spiral fragment (Fig. 5.128b) matches the spiral portion of the tail of that Crested Animal, while the long fragment with red spots (Fig. 5.128c) matches the straight horizontal base of its tail. Furthermore, the stirrup spout fragment (Fig. 5.126a) is almost certainly a match for the stirrup spout that is missing from the Crested Animal in Figure 5.112, but since it does not fit on that bottle, it must be from another one. These three fragments are from a vessel that was probably made by the same potter that made the Crested Animal in Figure 5.112, just as the vessels illustrated in Figures 5.113 and 5.120 were probably made by the same potter. It is not known why these three fragments were placed on the floor of the funerary chamber.



Figure 5.128 Vessel C15 found in the southeast corner of the burial chamber and three ceramic fragments from a similar vessel found nearby. a. stirrup spout fragment. b. curve of the tail. c. fragment of the base of the tail.

SUB-FLOOR BURIAL

There was a large oval area of soft soil on the floor of the burial chamber, directly beneath the funerary bundle. The clay floor was broken in this area, and the solid adobe masonry beneath it had been removed to create an oval burial chamber measuring approximately 200 centimeters north-south, 85 centimeters east-west, and 38 centimeters deep. The walls and floor of the chamber were irregular. On the floor was the skeleton of an adult male lying on his back in an extended position with his head to the south (Fig. 5.129).

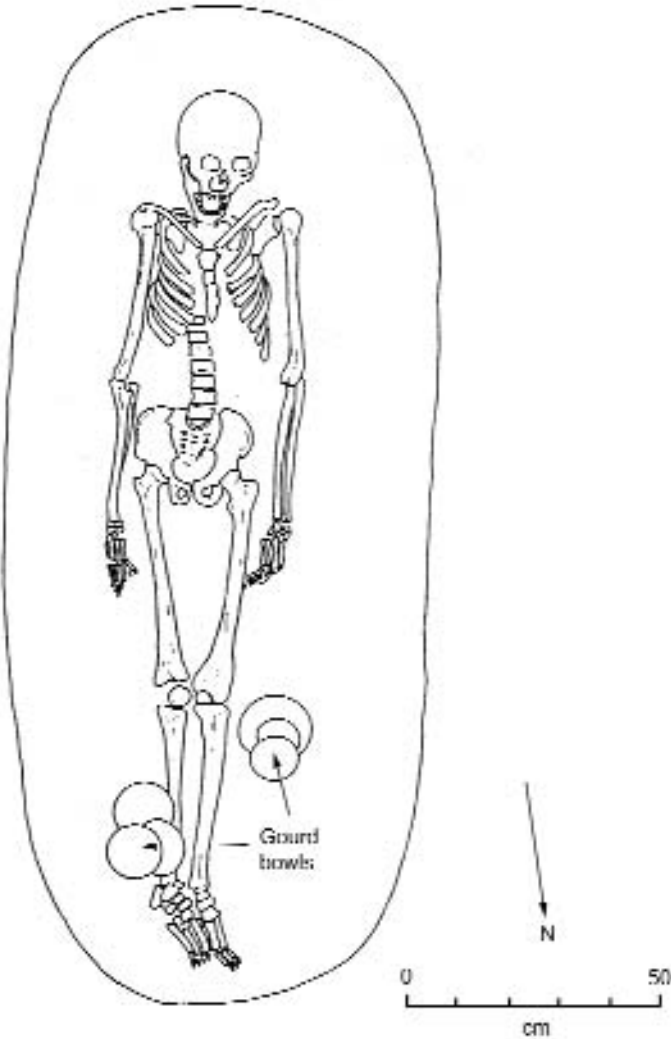

Figure 5.129 Sub-floor burial directly beneath the funerary bundle of the principal individual in Tomb 2.

Near his lower legs there had been two stacks of gourd bowls, all measuring between 12 and 14 centimeters in diameter (Fig. 5.129). Three were stacked over the individual's right leg and two others were stacked near his left knee.¹⁷

The only other object associated with this burial was a small piece of sheet copper near the individual's mouth. It was heavily corroded and shattered into so many pieces that its original form could not be determined. It may have been a copper nose ornament, and if so, he was probably wearing it at the time he was buried. There was no evidence that he had been dressed in garments or wrapped in a funerary bundle, but these may have decomposed. He was approximately 18 years old at the time he died. There was no evidence of the cause of death. His stature is estimated to have been 165–167 centimeters — within the normal range for adult Moche males.

Once the individual and associated burial offerings were placed on the floor of this chamber, it was filled with dirt and chunks of broken adobe — presumably the material that was broken out of the pyramid's solid adobe masonry when the chamber was created.

COMPARTMENT 2

Approximately 38 centimeters north of Tomb 2 there was a rectangular compartment that measured approximately 87 centimeters north-south, 84 centimeters east-west, and 62 centimeters deep.¹⁸ It had been formed by breaking adobes out of the pyramid's solid adobe masonry, and thus all four walls and the floor were irregular. Its upper edge was on the same level as the upper edge of the burial chamber of Tomb 2.

The compartment was filled to its upper edge with dirt and chunks of broken adobe. Approximately 6 centimeters below its upper edge, there were ofrendas and llama offerings (Fig. 5.130). The ofrendas were arranged in two groups of ten, one forming a line near the south side of the compartment (Fig. 5.130-C1–C10) and the other forming a line along the north side (Fig. 5.130-C15–C24). One of the latter, C16, is unique among all of the ofrendas in the tombs because it was painted with red slip before it was fired (Fig. 5.131).

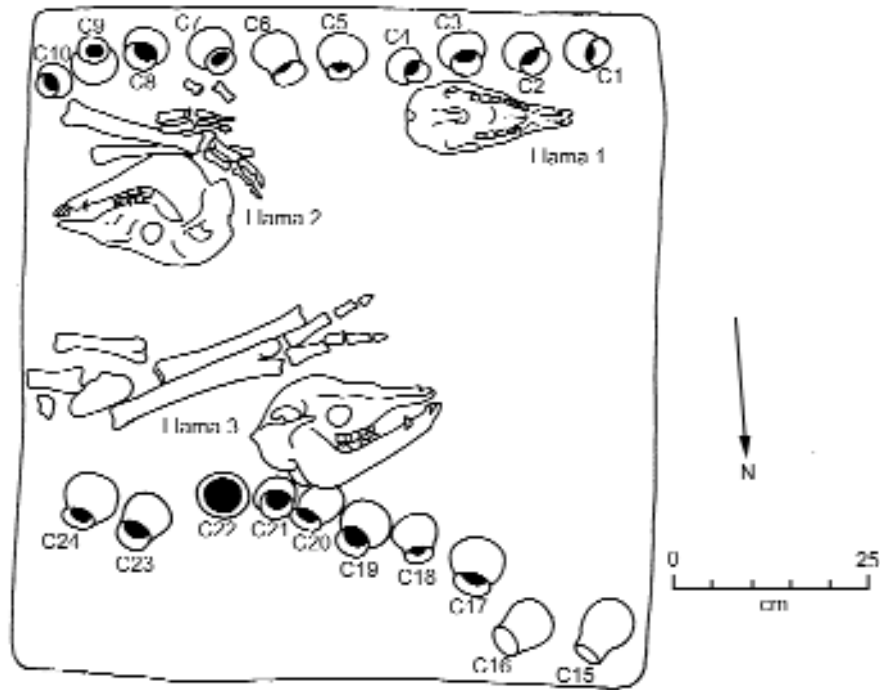

Figure 5.130 The upper layer of objects inside Compartment 2.

Between the two rows of ofrendas were three llama offerings. The one in the southwest corner of the compartment consisted of only the skull, whereas the other two, at the north end and southeast corner, consisted of the skull, legs, and toes. The ofrendas and llama offerings in this upper level were placed in fill consisting of dirt and chunks of broken adobes.

Approximately 17 centimeters below the upper edge of the compartment the fill changed abruptly to clean grayish white sand — similar in color and texture to the sand that had been spread over the floors of Tomb A, Tomb B, and Tomb 2. In the upper part of this fill were four ceramic bottles that had been broken by compression of the soil above them (Fig. 5.132). Along the east side of the compartment was a blackware stirrup spout bottle in the form of a reclining feline (Fig. 5.132 C1, Fig. 5.133), nearly identical to the partial feline bottle found in Tomb B (Fig. 3.16). Adjacent to it was a blackware double-chambered whistling bottle in the form of a parrot (Fig. 5.132 C2, Fig. 5.134).

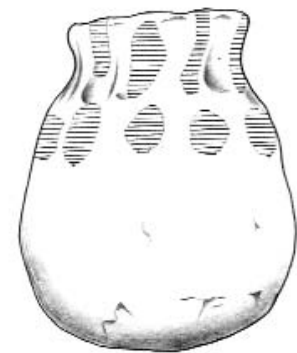

Figure 5.131 Ofrenda C16 with traces of red slip paint (height 6.3 cm).

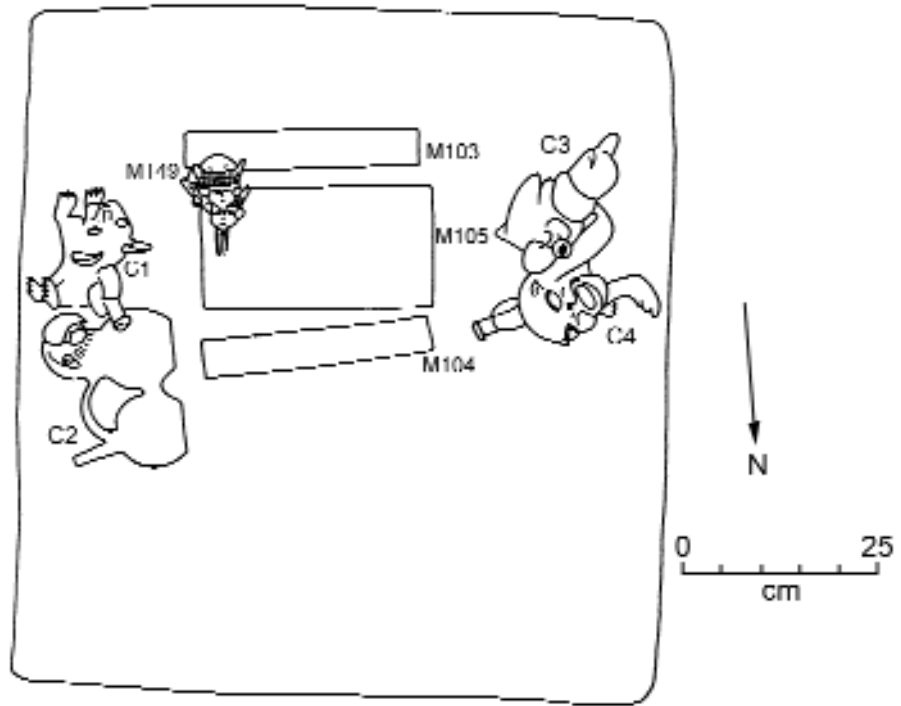

Figure 5.132 Second layer of objects inside Compartment 2.



Figure 5.133 Feline C1 (height 17.2 cm).



Figure 5.134 Parrot C2 (height 16 cm).



Figure 5.135 Condor C3 (height 20.3 cm).



Figure 5.136 Sea lion C4 (height 19 cm).

Along the west side of the compartment was a stirrup spout bottle in the form of a condor (Fig. 5.132 C3, Fig. 5.135). It is very similar to the one found in the northeast corner of Tomb 2 (Fig. 5.126) but is painted red on white rather than white on red. Adjacent to it was a blackware stirrup spout bottle in the form of a sea lion with its front flippers extending out to the sides (Fig. 5.132 C4, Fig. 5.136).

Approximately 34 centimeters below the upper edge of the compartment there was a stack of four small plumelike objects of gilded copper (Fig. 5.132 M149). They are identical in size and form to four others found inside the funerary bundle in Tomb 2 (Figs. 5.83, 5.84).

Beneath the plumelike objects were two headdresses. Both were made as cylinders, like most of the headdresses in Tomb 2. The center headdress (Fig. 5.132 M105) appeared to have been turned on its side and flattened like the headdresses in Tomb 2. It was then wrapped in a plain, open-weave cotton



*Figure 5.137 Headdress M105. Left, one of the platelets (height 4 cm).
Right, original appearance of the headdress.*

textile. It has rectangular platelets with four abstract bird heads (Fig. 5.137).

The other headdress (Fig. 5.132 M103, M104) consists simply of two decorated bands found parallel to one another, one on the north side and one on the south side of the previous headdress. The bands were so far apart in the compartment that they probably had not been assembled into a headdress, but in form and decoration they are so similar to bands used in other headdresses found in Tomb 2 that there is little doubt of their function. They may have been intended for a headdress with the two bands adjacent to one another (Figs. 5.138, 5.139), or they may have had a space between them, like the headdresses illustrated in Figures 5.28 and 5.31. The bands were decorated in low relief with what appear be Crested Animals.¹⁹



Figure 5.138 A portion of a decorated band from Headdress M103, M104 after cleaning (height 4.8 cm).

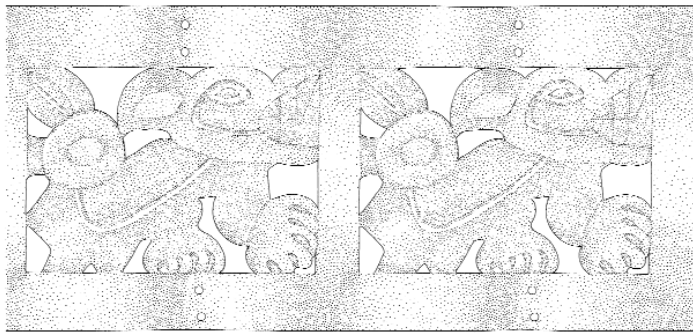

Figure 5.139 Headdress M103, M104. Left, a portion of one of the decorated bands (height 4.8 cm). Right, original appearance of the headdress.

In the third layer of objects inside the compartment there were three more headdresses (Fig. 5.140). One consisted of two rows of small rectangular platelets decorated with human faces (Fig. 5.140 M106, Fig. 5.141). Another had tall vertical platelets depicting human figures holding staffs and wearing headdresses with an animal or animal pelt (Fig. 5.140 M101, Fig. 5.142). The third headdress (Fig. 5.140 M102) is badly decomposed but appears to have been a donut-shaped ring, similar to the donut-shaped head ring found in Tomb 2 (Fig. 5.12 M74). This one, however, had a feline head, feline claws, and metal discs attached to it. The claws, ears, and pelt of the feline are made of sheet metal, while the eyes are of shell. Although this headdress was too decomposed to reconstruct, it appears to have been similar to the feline head rings depicted in Moche art (Fig. 5.143).

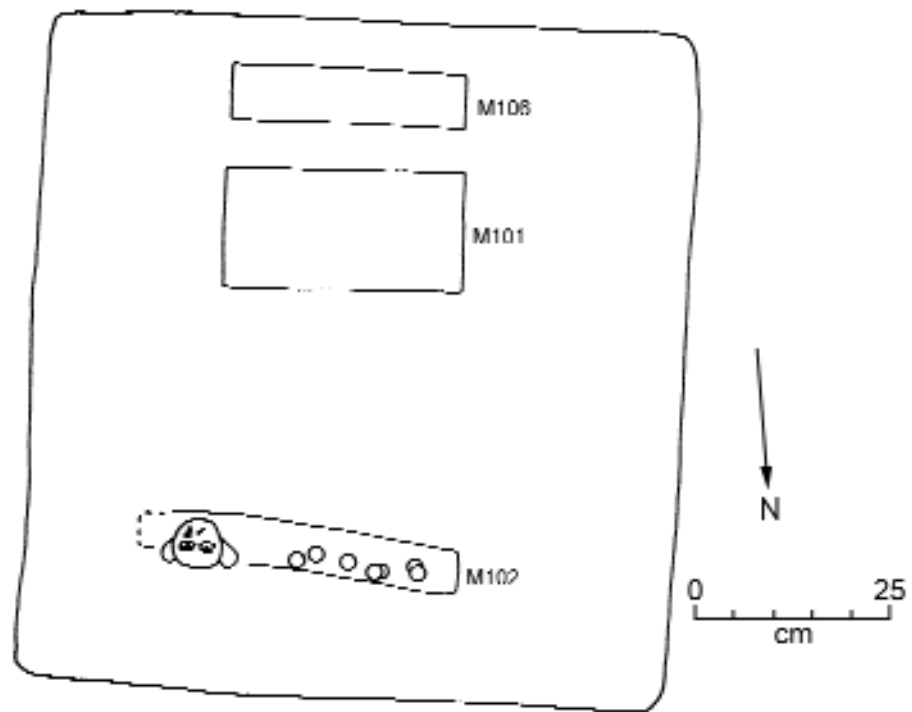

Figure 5.140 Third layer of objects inside Compartment 2.

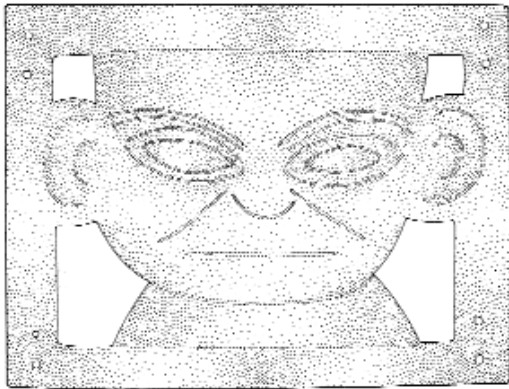

Figure 5.141 Headdress M106. Left, one of the platelets (height 3.7 cm).
Right, original appearance of the headdress.

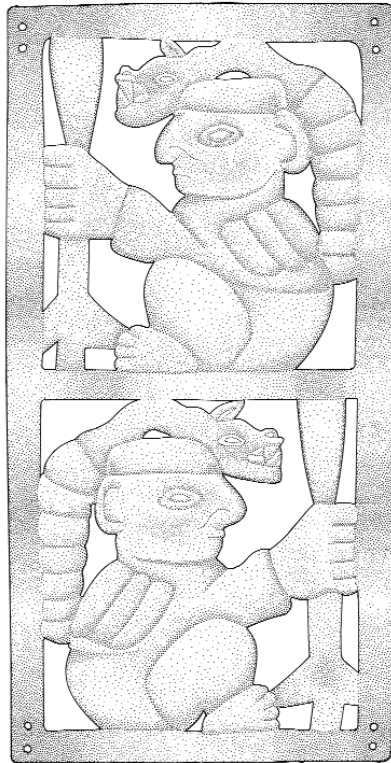

Figure 5.142 Headdress M101. Left, one of the platelets
(height 12 cm). Right, original appearance of the headdress.



Figure 5.143 Moche ceramic vessel depicting a feline headdress, apparently similar to Headdress M102. Not from Dos Cabezas.

On the floor of the compartment was a bundle of decomposed textiles. Inside it was a small human figure of sheet metal that was very similar in size and form to the one found on top of the roof of Tomb A (Figs. 2.3, 2.7, 2.8). And like that one, it was lying on its back with its head to the south (Figs. 5.144, 5.145). This one, however, was associated with numerous miniature objects, nearly all of which were tiny versions of the objects inside the funerary bundle of Tomb 2.



Figure 5.144 Copper figure and associated objects on the floor of Compartment 2.

Above the body of the copper figure were two miniature shields. The one placed over the feet had rectangular platelets (Fig. 5.145 M116, Fig. 5.146a), while the one over the torso had triangular platelets (Fig. 5.145 M115, Fig. 5.146b). They were very similar to two of the shields found in Tomb 2 (Figs. 5.40, 5.41). There were also two miniature war clubs: one of wood along his left side (Fig. 5.145 W101, Fig. 5.146c,) and the other of wood and copper along his right side (Fig. 5.145 M121, Fig. 5.146d). The latter had a hollow club head, made of sheet copper, like the scepter in Tomb 2 that rattled (Figs. 5.103, 104).

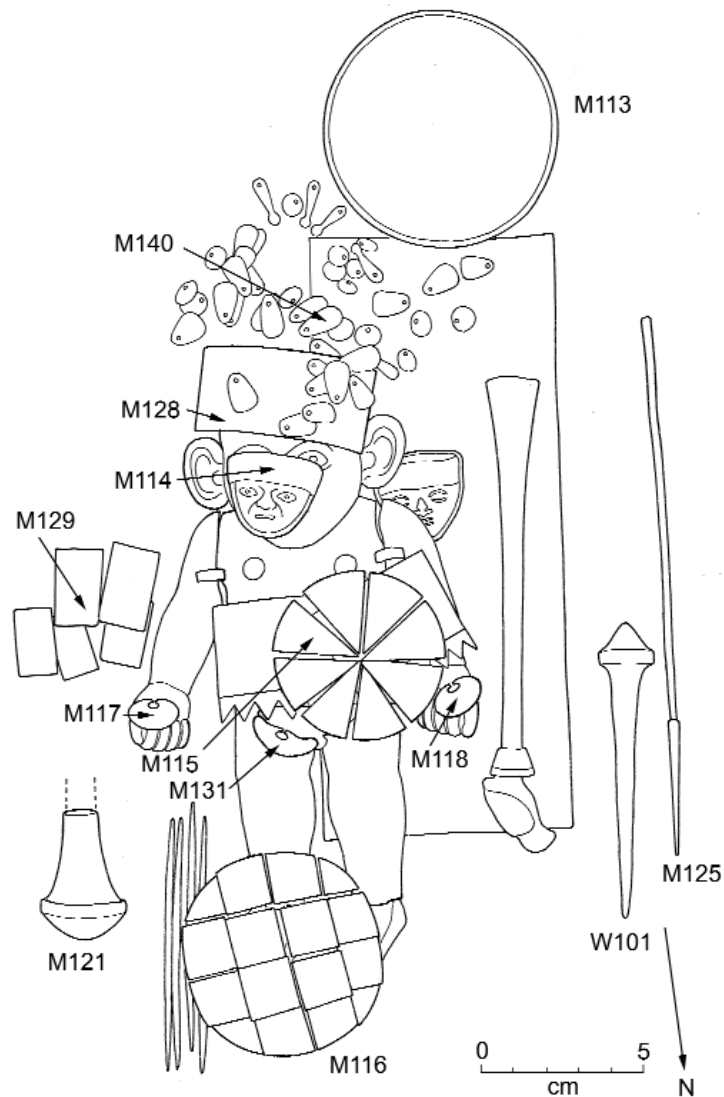

Figure 5.145 Copper figure and associated objects on the floor of Compartment 2.



Figure 5.146 *Miniature objects associated with the copper figure on the floor of Compartment 2.*

South of the copper figure was a round cup-like object (Fig. 5.145 M113, Fig. 5.146g), probably the counterpart of the large copper bowl that was turned upside down over the head of the deceased in Tomb 2 (Fig. 5.13). Over his face was a miniature burial mask (Fig. 5.145 M114, Fig. 5.146h) — the counterpart of the burial mask over the face of the individual in Tomb 2 (Figs. 5.48–5.52). Above the head of the copper figure were numerous circular and elliptical platelets that may have been attached to a head cloth (Fig. 5.145 M140, Fig. 5.147) — miniatures of the ones that were apparently on a head cloth above the burial mask in Tomb 2 (Figs. 5.48, 5.49).

Above each hand of the copper figure was a miniature oval nose ornament of gilded copper (Fig. 5.145 M117, M118, Fig. 5.146e, f).²⁰ Another miniature nose ornament was over the upper part of his right leg (Fig. 145 M131).

Over the figure's forehead was a miniature headdress made of a single band of gilded copper (Fig. 5.145 M128, Fig. 5.146i). It would have been similar to the full-sized headdress that was closest to the head of the individual in Tomb 2 (Fig. 5.37, but it did not have discs around the upper and lower edges. Another miniature headdress, made of separate platelets of copper, was adjacent to the figure's right arm (Fig. 5.145 M129, Fig. 5.146j). It was presumably meant to be a miniature of a full-sized headdress with platelets like one of those in the Tomb 2.

As some of these objects were removed, additional objects were revealed (Figs 5.148, 5.149). South of the figure's head was another miniature headdress made of separate platelets of gilded copper (Fig. 5.149 M130, Fig. 5.150a). It still had remnants of a miniature basketry cylinder that the platelets had been sewn to — the counterpart of the full-sized basketry cylinders that were used in constructing the headdresses in Tomb 2. Over his lower torso was a miniature shirt with triangular elements along its hem (Fig. 5.149 M134, Fig. 5.150b) — the counterpart of the shirt with triangular elements forming the hem in Tomb 2 (Fig. 5.30 M71).

Beneath the left shoulder was a mask, very similar to the one over the individual's face (Fig. 5.149 M112, Fig. 5.150c). In this instance, however, it was facing down. Perhaps it was meant to be the counterpart of the one found under the neck of the deceased in Tomb 2 (Figs. 5.73, 5.74). We did not find

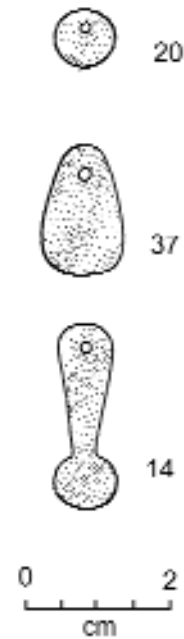

Figure 5.147 The types of gilded copper platelets found above the head of the copper figure (Fig. 5.145 M140), with the number of each that were recovered.



Figure 5.148 Copper figure and associated objects on the floor of Compartment 2.

the metal hands and feet that would have been associated if it was the counterpart of the accessory worn on the back, but it is possible that they were made of perishable material and had decomposed.

On the west side of the copper figure, adjacent to the wooden war club, was a miniature spear consisting of a long wooden shaft and a copper spear point (Fig. 5.149 M125, Fig. 5.150d). In addition, there were three similar copper points (Fig. 5.150e), like the full-sized copper points found in Tomb

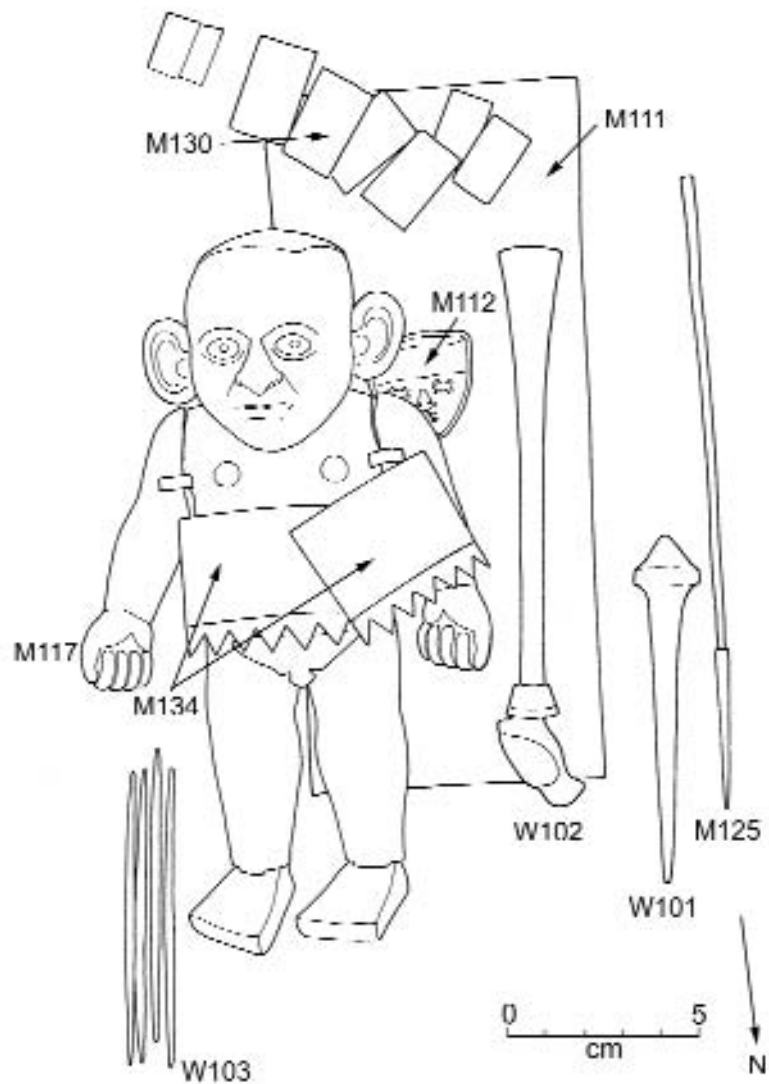

Figure 5.149 Copper figure and associated objects on the floor of Compartment 2.

2 (Fig. 5.99). Near the right foot of the figure were five wooden darts (Fig. 5.149 W103, Fig. 5.150f), miniatures of the dart points found in Tomb 2 (Fig. 5.89). Adjacent to his left arm was a long wooden staff with its upper end carved in the form of an owl (Fig. 5.149 W102, Fig. 5.150g).

Partially under the figure's body was a large rectangular object of copper (Fig. 5.149 M111). It may represent the cane or wooden frame that is sometimes placed beneath the body of the deceased in Moche burials to keep



Figure 5.150 Miniature objects associated with the copper figure on the floor of Compartment 2.

the body rigid (Donnan 1995:125–134). There may have been a frame under the body of the deceased in Tomb 2, but nearly all of the organic material in that burial had decomposed, and no evidence for a frame was recovered.

In addition to these objects, there were other diminutive versions of objects found in Tomb 2. These included a miniature axe-like implement (Fig. 5.150h) like the one in Tomb 2 (Fig. 5.15), a miniature chisel (Fig. 5.150i) like the one in Tomb 2 (Fig. 5.96), and three miniature head-dress ornaments (Fig. 5.150j–l) like those in Tomb 2 (Fig. 5.29). There was a miniature spear thrower (Fig. 5.150m) like the one with gilded copper bands in Tomb 2 (Fig. 5.86), a miniature implement with a sphere at one end (Fig. 5.150n) similar to the one in Tomb 2 (Fig. 5.102), and a tiny wooden object carved in the form of a human head on top of a drum (Figs. 5.150o, 5.151). The latter was similar to the larger version found in Tomb 2 (Fig. 5.105).

Finally, there were additional triangular elements, presumably from a shirt (Fig. 5.150p), that may have been from a second shirt like the one found over the figure's torso (Fig. 5.150b), but made of textile rather than metal. The two sizes of triangular elements parallels the two sizes of triangular elements found in Tomb 2 (see Fig. 5.33).

The copper figure, like the one found on the roof of Tomb A, had neither clothing nor headdress (Fig. 5.152). One nipple and his naval are represented by gilded copper discs, and his genitals are represented with another sheet of gilded copper. He had been wrapped, along with his associated miniature objects, in textiles to form a miniature funerary bundle. Clearly, he was meant to be a miniature of the individual buried in Tomb 2, with a very similar inventory of associated miniature objects.



Figure 5.151 Wooden object depicting a head on a drum-shaped base (height 2.6 cm).



Figure 5.152 The copper figure in Compartment 2 (height 19.6 cm).

NOTES

¹ The original field number of this tomb is A53T1.

² The transverse beams were approximately 10 centimeters higher on the west side of the tomb than they were on the east side, and thus the roof would have sloped down slightly to the east.

³ Moche burials often exhibit special care in encasing and/or protecting the head of the deceased. This is reflected in the greater quantity of rope used to wrap the head end of a cane coffin compared to that used to wrap the other parts (Donnan and Barreto 1997:260).

⁴ The transverse beam at the north end of the tomb may have broken before the space beneath it was filled with soil. As a result, that portion of the roof collapsed into the burial chamber, breaking some of the adobes that were above the roof beams. The other roof beams appear to have decomposed when the area beneath them had already filled with soil, thereby preventing a collapse similar to that which occurred at the north end.

⁵ This sand is similar to the sand found on the floors of Tomb A and Tomb B.

⁶ There was, however, nothing holding them together. Moreover, because they were made of gilded copper they were badly oxidized and extremely fragile. Many had shattered into small pieces.

⁷ One Moche headdress, made over a donut-shaped ring of junco grass covered with textile, was excavated in the Viru Valley (Strong and Evans 1952: 159; Donnan 2004: 62)

⁸ The only Moche banners that have been found previously were in the royal tombs of Sipán (Alva and Donnan 1993:64–67).

⁹ The Moche often placed metal objects in the mouth of the deceased before they were buried — most often a copper ingot or part of a broken copper implement (Donnan 1995:147).

¹⁰ A pair of sheet metal warriors was found at Loma Negra, one wearing the human accessory and the other a feline accessory (The Metropolitan Museum of Art, New York, catalogue numbers 1981.459.31 and 1981.459.32).

¹¹ This is consistent with beliefs and practices of the native people of Peru at the time of European contact. Early Colonial Period accounts state that the native people believed in the duality and complementarity of right and left halves. They associated gold with masculinity and the right side and silver with femininity and the left side. Placement by the Moche of gold on the right and silver on the left strongly suggests that these metal and gender associations were also part of their culture.

¹² In Moche funerary practice, metal objects were often placed in the mouth and hands of the deceased (Donnan 1995:147).

¹³ The chisel weighs 859 grams and is one of the heaviest Moche metal objects ever reported.

¹⁴ These beads are remarkably similar to beads that were looted from a tomb at Sipán (Alva and Donnan 1993:Figs. 24, 25).

¹⁵ This style of ceramics has often been seen as Viru (or Gallinazo), but we now realize it is a style of domestic ware that was made and used by the Moche.

¹⁶ There are other Moche ceramics depicting figures similar to this one. The figures usually have a contorted face, a shallow container with round objects beneath their torsos, and similar round objects on their body. They are thought to portray individuals who are suffering from an illness that causes sores on the body.

¹⁷ These appeared as two voids that had been formed when the gourd vessels decomposed, leaving their impressions in the soil around them. Therefore, the voids were cast with plaster before the soil around them was excavated.

¹⁸ The original field number of this compartment is A53RN.

¹⁹ The lower part of their body is serrated like the lower body of a sea-horse, similar to the way the Crested Animal is depicted in Figure 5.120. Although they do not have crests on their heads, their ears, eyes, and snouts are similar to those of Crested Animals.

²⁰ The individual in Tomb 2 did not have nose ornaments on or under his hands, but the individual in Tomb 1 (see Chapter 7) had an oval copper nose ornament under each hand.



Chapter 6

TOMB 3

The burial chamber of Tomb 3 was located approximately 240 centimeters north of Compartment 2 (Fig. 6.1).¹ It had a roof supported by wood beams, with a layer of adobes on top. Above these adobes, at the north end of the tomb, was a person approximately 11 years of age who was lying face up with feet to the west and head to the east (Figs. 6.2, 6.3). Although the sex of the individual could not be determined from the skeletal remains, it seems likely that it was a female, analogous to the young female on top of Tomb 2. Moreover, a spindle whorl (Fig. 6.4) was found next to one of the individual's finger bones, and spindle whorls in Moche burials are almost invariably found with females (Donnan 1995:150).

When the roof beams decomposed and fell inside the burial chamber, the layer of adobes above them also fell, along with the individual. This left the adobes so broken and out of position that their original placement could not be reconstructed (Fig. 6.5). Therefore it is not possible to determine whether they had been arranged in sets like the adobes above the roof of Tomb 2 (Fig. 5.5).

The roof of Tomb 3 was constructed in a different way than the roof of Tomb 2. There were ten roof beams, all of which extended east-west. Their west ends rested on the upper edge of the burial chamber and their east ends were supported by a post-and-beam frame. This frame had one post in the southeast corner, one in the northeast corner, and a beam extending north-south on top of them. The lower half of the burial chamber appears to have been deliberately filled with soil and broken adobes before the roof was constructed; the posts of the frame rested on this fill rather than on the tomb floor. The frame was kept upright by simply leaning it against the east wall of the burial chamber. At the time that the roof was constructed, the upper half of the burial chamber was empty.

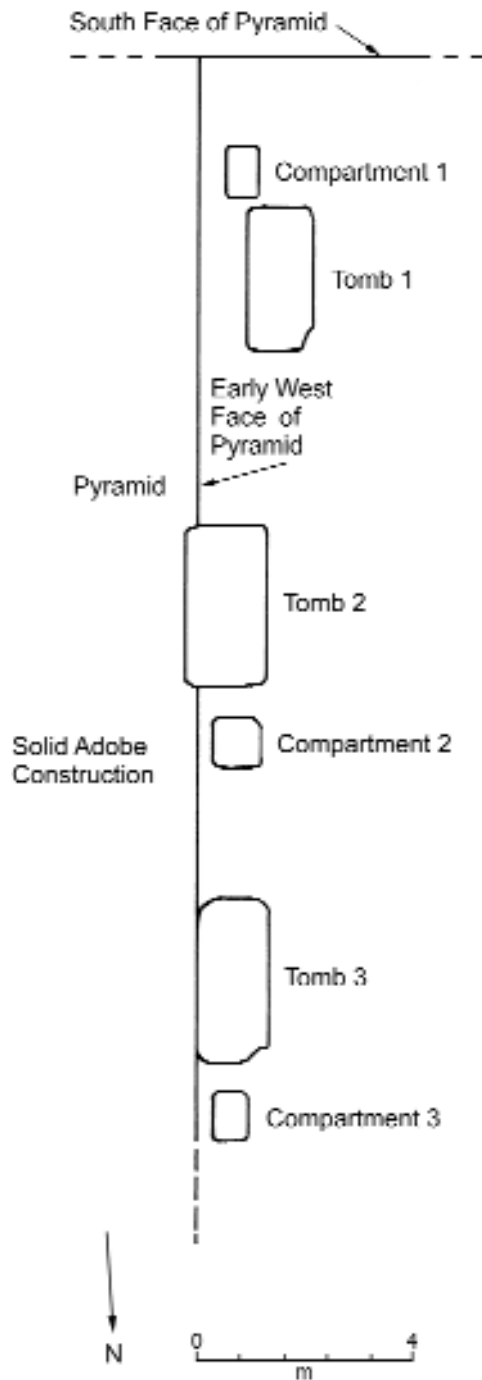

Figure 6.1 Plan of the three tombs in the solid adobe pyramid.



Figure 6.2 View looking north at the individual whose body fell into the tomb chamber when the roof collapsed.

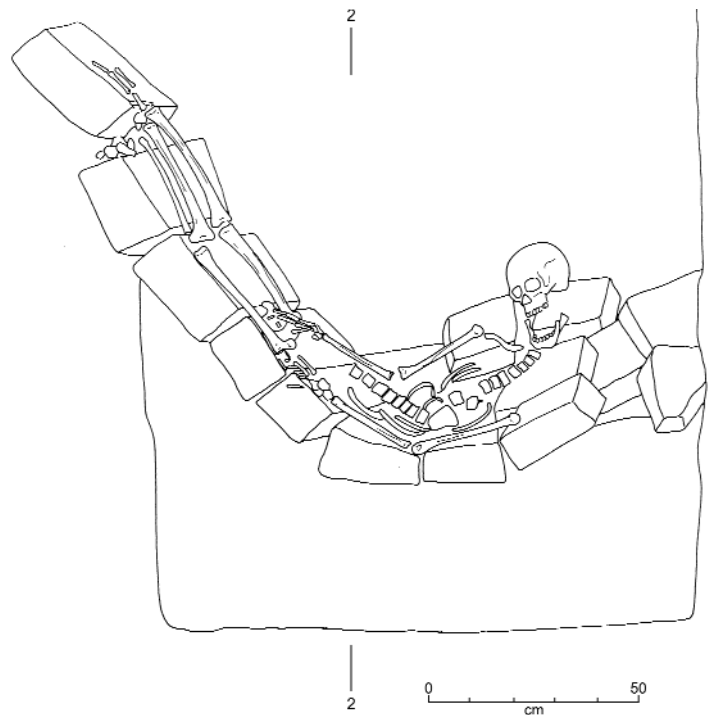

Figure 6.3 View looking north showing the individual's position relative to the burial chamber.

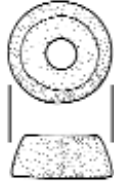

Figure 6.4 Spindle whorl (diameter 1.7 cm) associated with the individual whose body fell into the burial chamber when the roof collapsed.

The upper edge of the burial chamber was on the same level as the upper edge of the burial chamber of Tomb 2. It measured approximately 300 centimeters north-south by 132 centimeters east-west, and 87 centimeters deep. Like the burial chamber of Tomb 2, it was located where water had eroded a pocket into the west wall of the pyramid where it adjoined the top of the solid adobe matrix that was being constructed to expand the pyramid and create a new west face (Fig. 4.22). The burial chamber was made by enlarging this eroded pocket – breaking out adobes from both the old and the new construction. As a result, its walls and floor were irregular.

There were two individuals on the floor of the burial chamber. One was a child, approximately nine years of age, whose sex could not be determined. It was on the east side of the floor, lying fully extended on its back with the head to the south (Figs. 6.6, 6.7). There was only a small fragment of textile associated with this individual; the body may not have been dressed or wrapped in a shroud when it was buried. The other individual was an adult male who was wrapped in many layers of textiles, forming a large funerary bundle that was placed near the center of the floor.

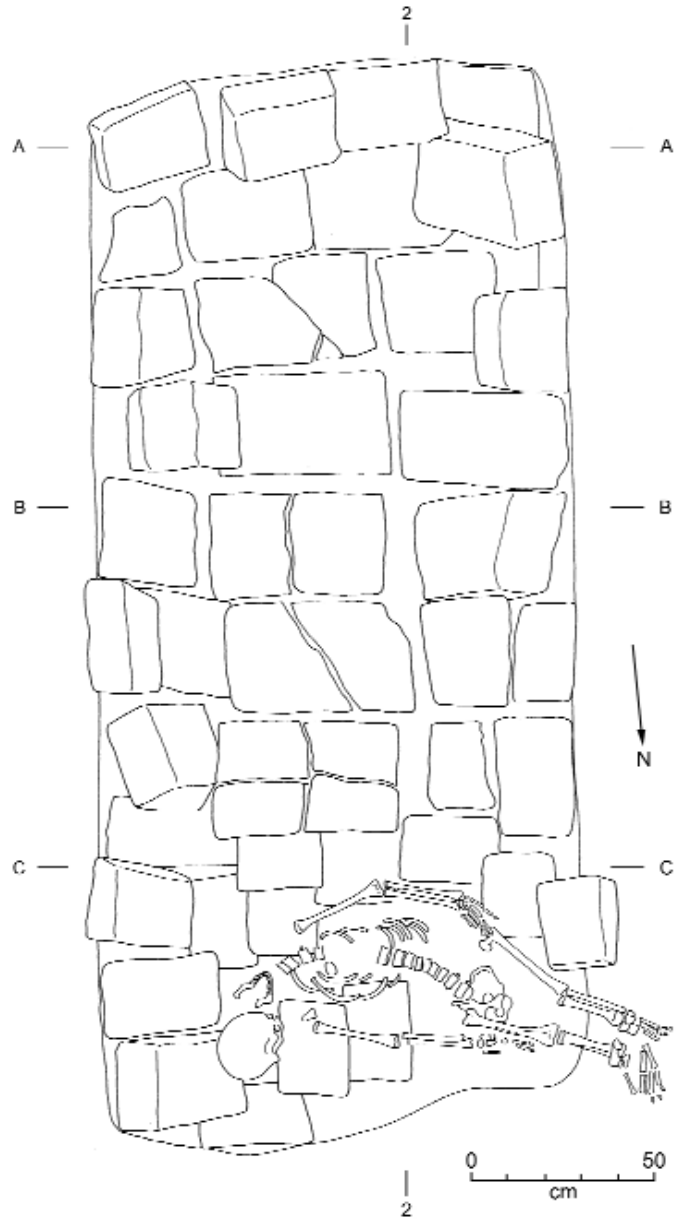

Figure 6.5 Plan of the adobes and the individual whose body fell into the burial chamber when the roof collapsed.



Figure 6.6 The floor of Tomb 3.

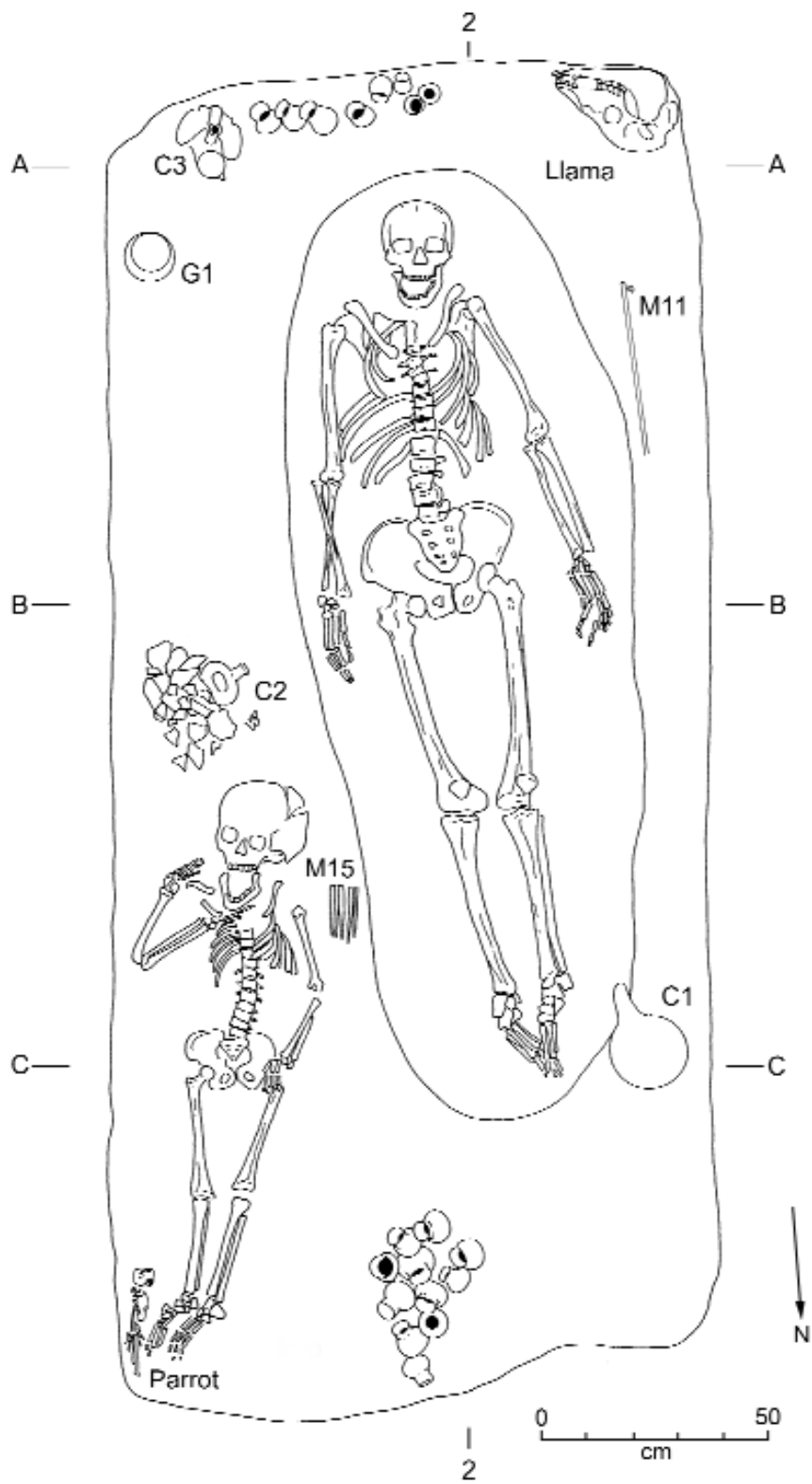

Figure 6.7 Plan of the floor of Tomb 3.



Figure 6.8 Dipper C1 (length 24.5 cm).



Figure 6.9 Bird C3 (height 17 cm).



Figure 6.10 Lizards C2 (height 18.8 cm).



Figure 6.11 Copper points M15 (height of longest 11.4 cm).

Various objects were on the burial chamber floor. There was a parrot skeleton in the northeast corner, a llama skull in the southwest corner, a dipper along the west wall (Fig. 6.7 C1, Fig. 6.8), and two stirrup spout bottles. One, near the southeast corner, was blackware, sculpted in the form of a bird (Fig. 6.7 C3, Fig. 6.9). The other, near the east wall, was made of white clay, with the chamber depicting four lizards (Fig. 6.7 C2). It was shattered from the compression of the soil above the tomb but could be reconstructed (Fig. 6.10). There were also two clusters of ofrendas: eleven at the north end of the burial chamber and eight at the south end.

There was a small gourd bowl near the southeast corner (Fig. 6.7 G1).² Near the left shoulder of the child was a cluster of nine copper points (Fig. 6.7 M15, Fig. 6.11), probably for spears that were thrown with a spear thrower. They had a residue of string wrapped around their bases, which probably served to fit them snugly into cane shafts. They may have had shafts when they were put into the grave; if so, the shafts had decomposed. On the west side of the bundle there was a spear thrower with a simple copper engaging spur (Fig. 6.7-M11, Figs. 6.12, 6.13). It is similar to the one on the plain spear thrower found in Tomb 2 (Figs. 5.97, 5.98).



Figure 6.12 Engaging spur of spear thrower M11, with residue of the wooden shaft.

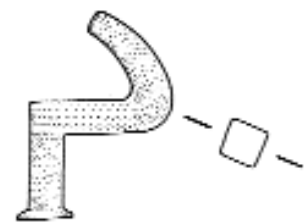

Figure 6.13 Engaging spur of spear thrower M11 (height 2.7 cm.).



Figure 6.14 The floor of Tomb 3 with the interior of the funerary bundle exposed.

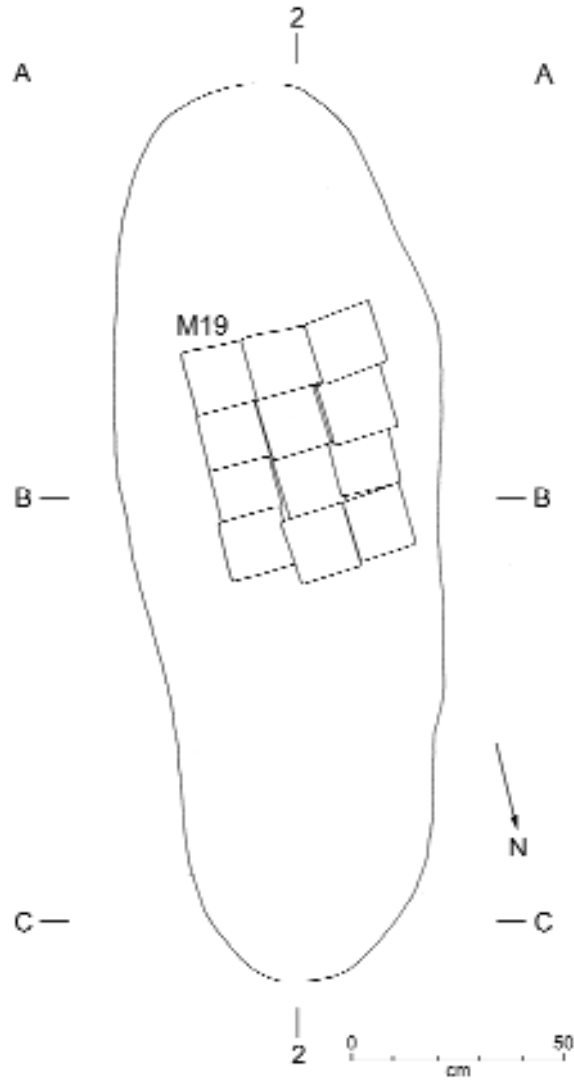

Figure 6.15 Plan of the upper level inside the funerary bundle.

The textiles that formed the funerary bundle of the adult male had almost entirely decomposed to a powdery mass. Many objects had been placed within them when they were wrapped around the body, but due to the decomposition of the textiles, it was not possible to determine their original placement within the bundle.

Over the individual's body was a large rectangular object consisting of 12 square platelets of gilded copper, each measuring approximately 15 by 18 centimeters (Fig. 6.14, Fig. 6.15 M19). It covered the lower part of his torso, pelvis, and upper legs. Its function is not clear.

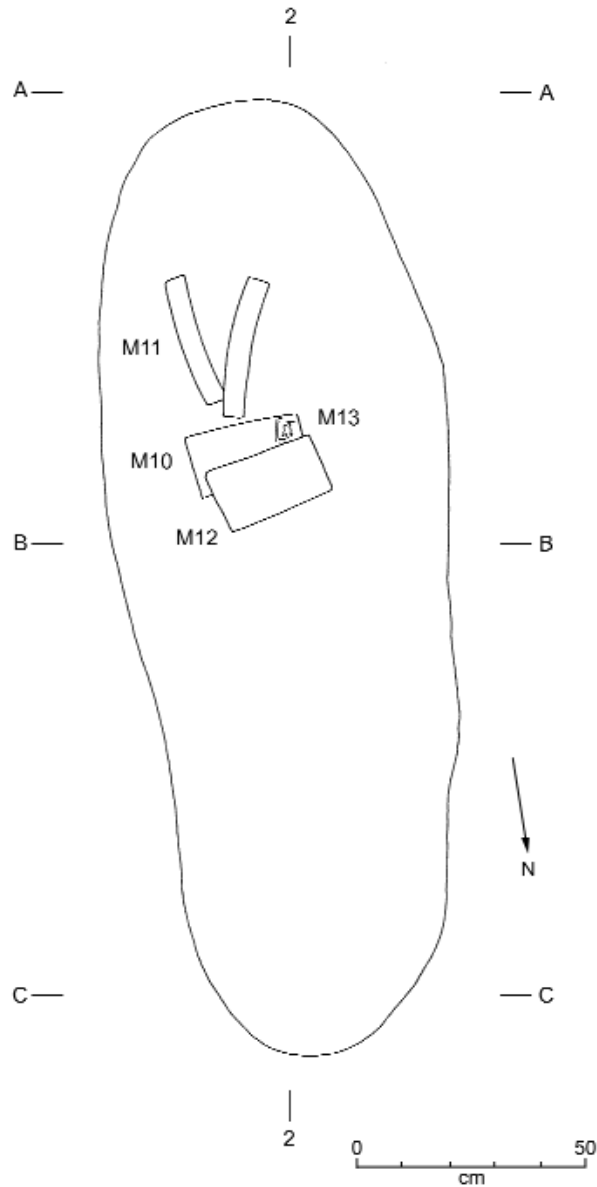

Figure 6.16 Plan of the second level inside the funerary bundle.

Under the object composed of rectangular platelets were fragments of at least two gilded copper birds (Fig. 6.16 M13, Fig. 6.17). They were badly decomposed but appeared to have been sewn to a textile, each with a rectangular frame consisting of a gilded copper band.

Beneath the birds were three headdresses. All were open-ended cylinders like those found in Tomb 2. One, which was over his chest, consisted of two undecorated bands of gilded copper (Fig. 6.16 M11, Fig. 6.18). The other

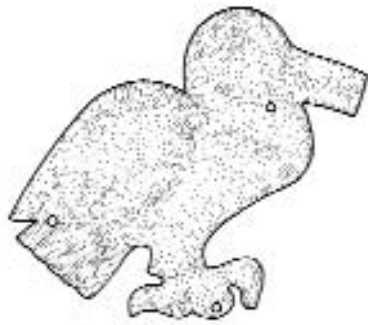

Figure 6.17 Gilded copper bird M13 (height 4.2 cm).

two, which were over his torso, were made with rectangular platelets of gilded copper. One had platelets depicting the Crested Animal (Fig. 6.16 M10, Fig. 6.19). The other had platelets depicting a condor eating a human head (Fig. 6.16 M12, Fig. 6.20).



Figure 6.18 Original appearance of Headdress M11.

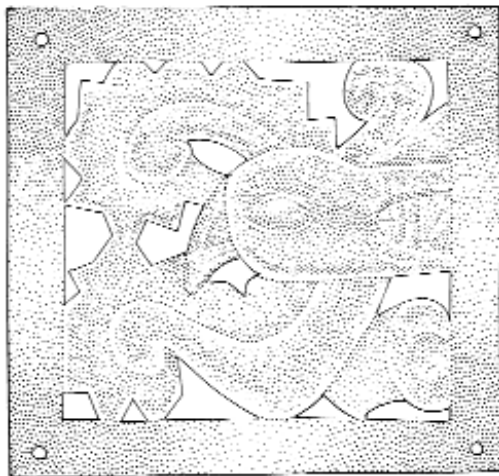

Figure 6.19 Headdress M10. Left, one of the platelets (height 3.9 cm). Right, original appearance of the headdress.

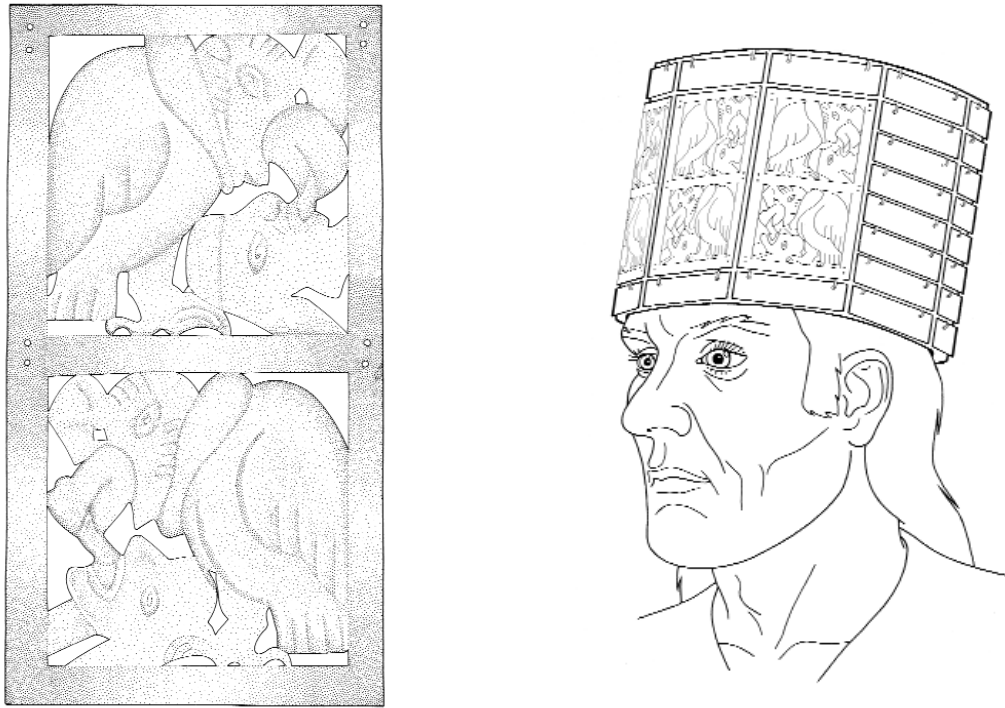

Figure 6.20 Headdress M12. Left, one of the platelets (height 11.6 cm). Right, original appearance of the headdress.



Figure 6.21 The principal individual wearing a beaded pectoral.

The adult male was buried wearing a beaded pectoral (Fig. 6.21). It is similar to the one excavated in Tomb 2 (Fig. 5.68) but smaller and with fewer beads and spacer bars. The tubular beads were made of shell, while the spacer bars were made of bone. Because both the beads and the spacer bars in this pectoral were better preserved than those in Tomb 2, it was possible to reconstruct its original form (Fig. 6.22). It is remarkably similar to a pectoral portrayed on a Moche ceramic vessel (Fig. 6.23).

There were nine nose ornaments in



Figure 6.22 Beaded pectoral (height 27 cm).

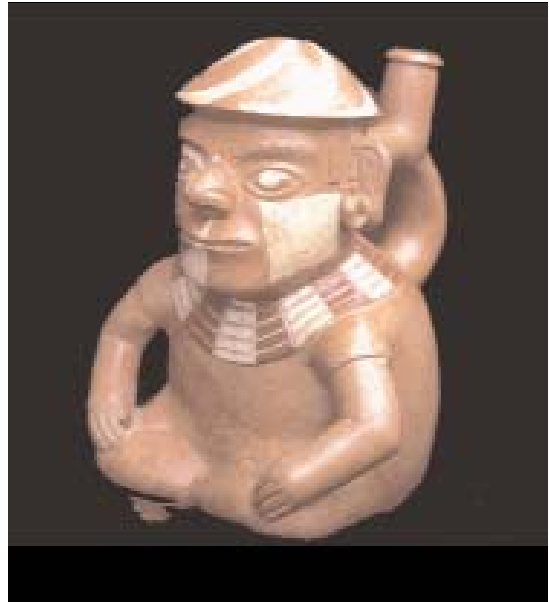

Figure 6.23 A Moche ceramic vessel showing an individual wearing a beaded pectoral. Not from Dos Cabezas.

the funerary bundle (Fig. 6.24). Two gold nose ornaments (Figs. 6.24a, c, 6.26) were over the individual's mouth and may have been worn by him when he was buried. In his mouth were two silver nose ornaments (Fig. 6.24g, i) and two small droplets of metal, one gold and the other silver. Beneath his chin were five more nose ornaments: four of gilded copper (Figs. 6.24b, d, f, h, 6.27) and one of silver (Figs. 6.24e, 6.25). The latter was elaborately decorated with representations of the Crested Animal; their eyes had been inlaid with black stones.



Figure 6.24 The nine nose ornaments found in Tomb 3.



Figure 6.25 Silver nose ornament shown in Fig. 6.24e (height 4.3 cm).



Figure 6.26 Gold nose ornament shown in Fig. 6.24c (height 4.3 cm).



Figure 6.28 The principal individual fully exposed.



Figure 6.27 Gilded copper nose ornament shown in Fig. 6.24b (height 2.5 cm).

The adult male was buried fully extended, lying on his back with his head to the south (Fig. 6.28). He was between 18 and 22 years of age. Like the individuals in Tomb A and Tomb 2, he was much taller than most Moche males; his height was approximately 175 centimeters.

COMPARTMENT 3

Like Tomb 2, Tomb 3 had a rectangular compartment. It was located approximately 45 centimeters north of Tomb 3 (Fig. 6.1) and was approximately 85 centimeters north-south, 68 centimeters east-west, and 40 centimeters deep.³ It was created by breaking adobes out of the pyramid's solid masonry construction, leaving the walls and floor irregular. Its upper edge was on the same level as the upper edge of Tomb 3. It had been filled with dirt and chunks of broken adobes, presumably material that had been broken out of the compartment during its construction.

On the floor of the compartment were two sets of ten ofrendas (Figs. 6.29–6.31): one set in southwest corner (Fig. 6.31 C1–C10) and another in the northwest corner (Fig. 6.31 C11–C20). There was also a llama skull near the center of the south wall (Fig. 6.31 L1).



Figure 6.29 The floor of Compartment 3.



Figure 6.30 The floor of Compartment 3 with the copper figure exposed.

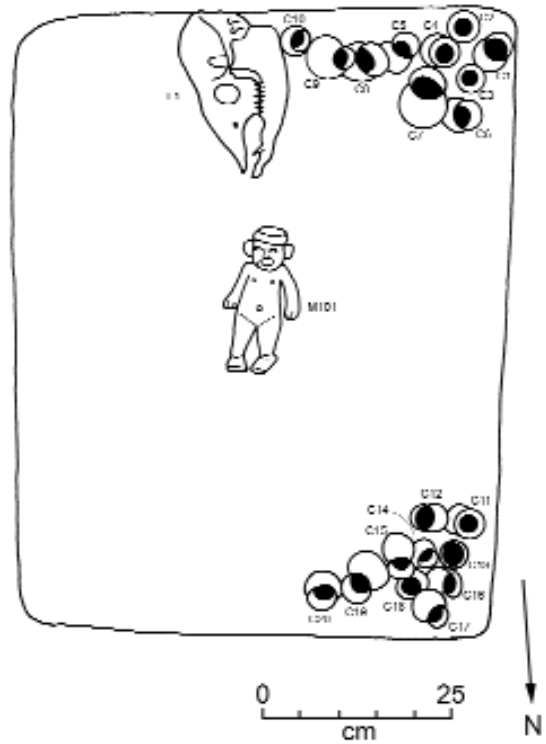

Figure 6.31 Plan of the floor of Compartment 3.



Figure 6.32 The copper figure of Compartment 2 in situ.



Figure 6.33 The copper figure M101 (height 18.3 cm) after cleaning.

In the center of the floor was a bundle of decomposed textiles. Inside it was a copper figure lying on his back with his head to the south (Figs. 6.30, 6.31 M101, 6.32, 6.33). It was very similar in size and form to the copper figures excavated in Tomb A (Fig. 2.8), and Compartment 2 (Fig. 5.152).

Clearly, Compartment 3 was meant to be a miniature of Tomb 3. The copper figure, wrapped in multiple layers of textiles and lying fully extended with its head to the south, was meant to be a miniature of the principal individual in Tomb 3.

For a variety of reasons that will be discussed in Chapter 8, Tomb 2 and Tomb 3 must have been contemporary with one another and completed at about the same time. Soon after their funerary rituals were completed, construction began again on the expansion of the west side of the pyramid. This is identified as Stage 10 in the construction sequence (Fig. 6.34). As the construction resumed, a layer of clay was spread over a large area, and while the

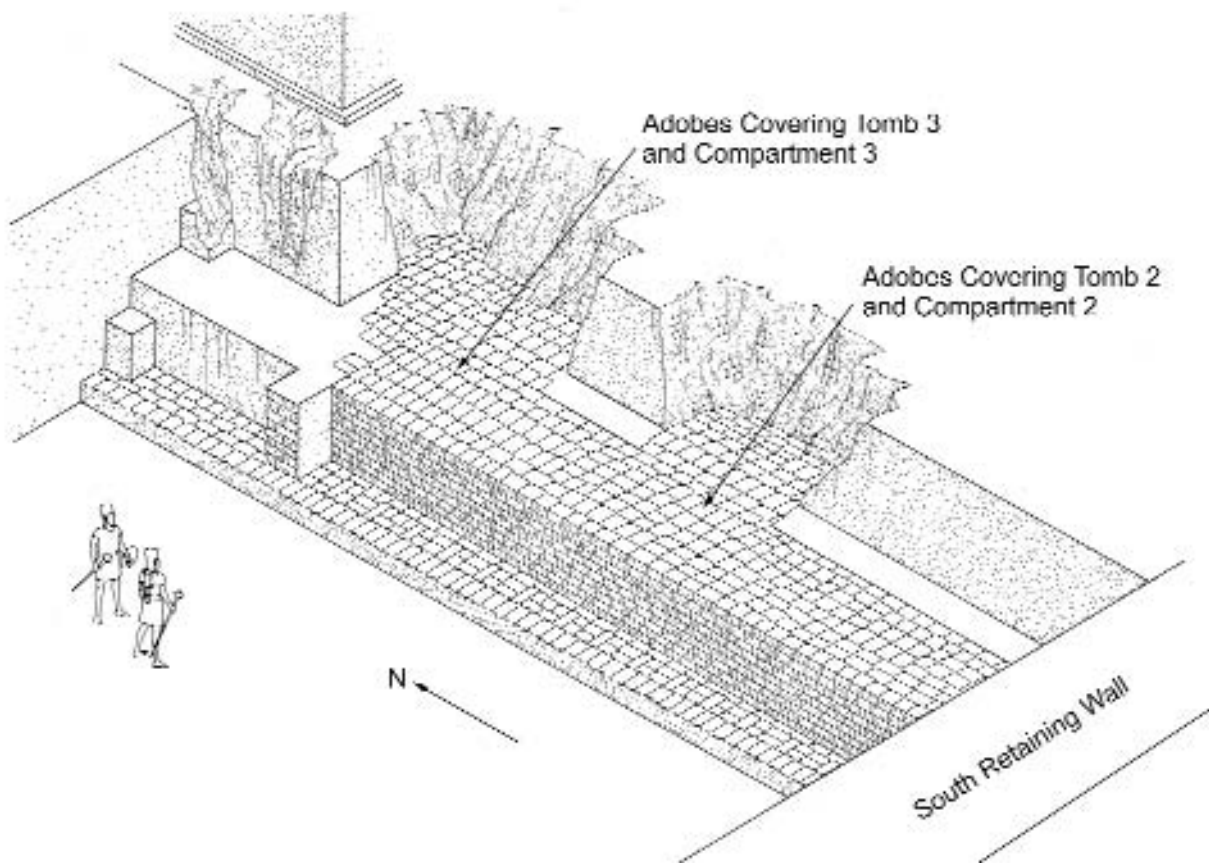

Figure 6.34 STAGE 10: Layers of adobes were added that covered Tombs 2 and 3 and their compartments.

clay was still moist it was covered with a layer of adobes. Dirt mixed with broken adobe was then filled in around the edges of the adobes, and another layer of clay was spread on top of them. Then another layer of adobes was put in place, and more dirt and broken adobes was filled in around them. This procedure was repeated to raise the height of the solid adobe masonry in the South Room while at the same time filling in the deep erosion channels that had been cut into the old west face of the pyramid.

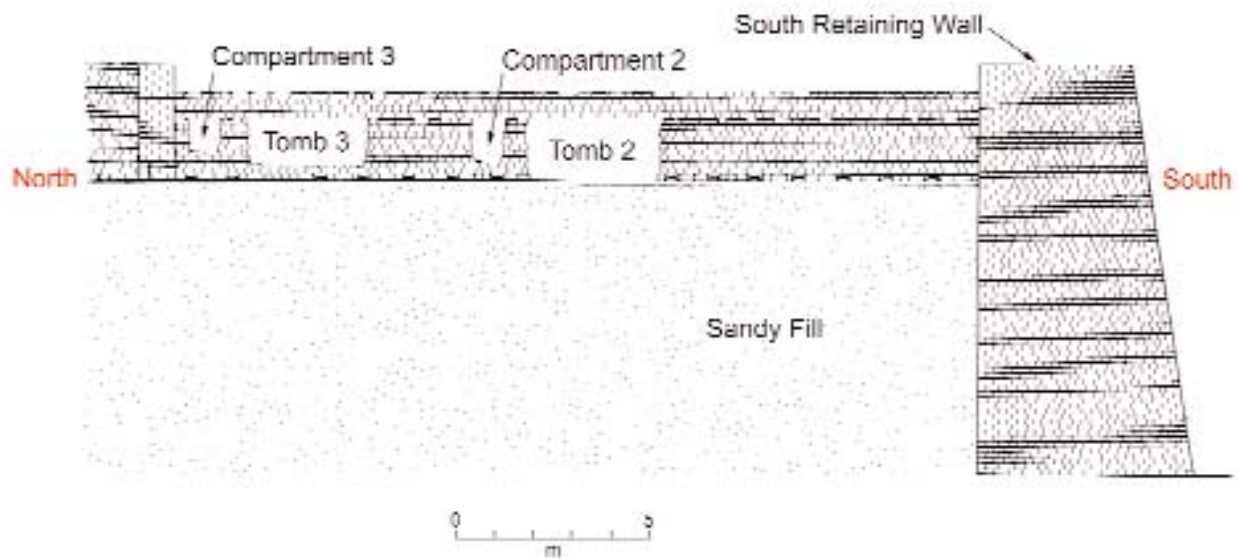

Figure 6.35 STAGE 9: North-south profile as indicated in Fig. 4.6, showing the burial chambers of Tomb 2 and Tomb 3 covered by layers of adobes that were added after their funeral rituals were completed.

When the construction reached the height of approximately 1 meter above the upper edges of the burial chambers of Tombs 2 and 3, the construction was temporarily halted. The burial chamber of Tomb 1 and its associated compartment were then constructed (Fig. 6.35). That tomb and compartment are discussed in the following chapter.

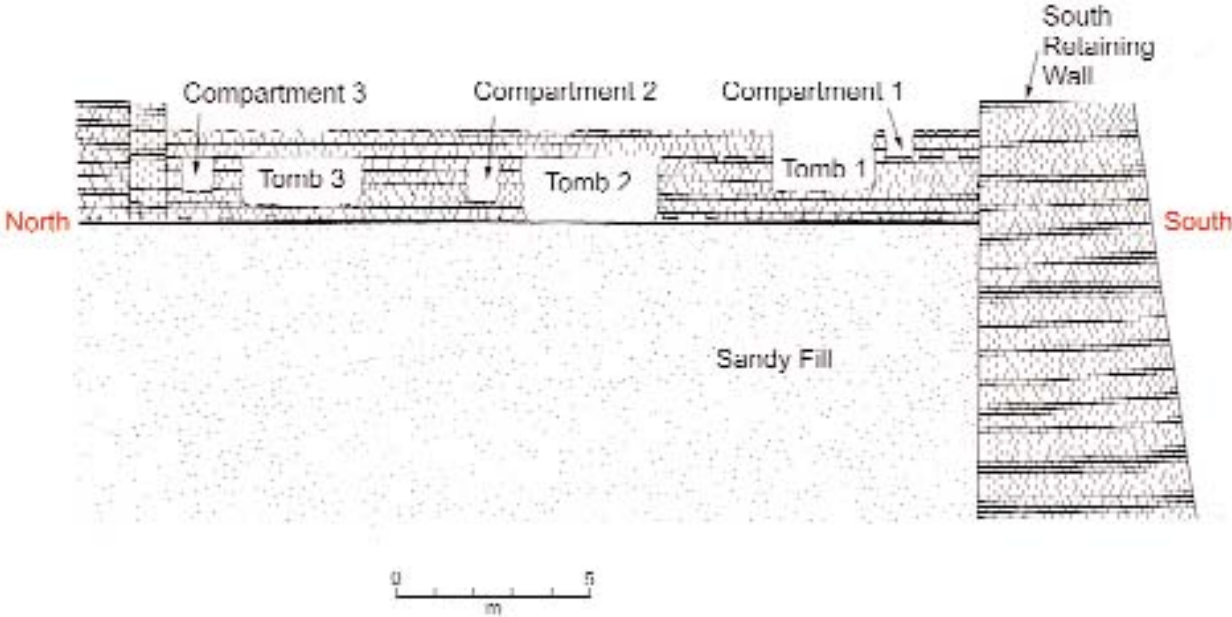

Figure 6.35 STAGE 10: North-south profile as indicated in Fig. 4.6, showing the burial chamber of Tomb 1 and its associated compartment, which were created after layers of adobes had been constructed above Tombs 2 and 3 and their associated compartments.

NOTES

¹The original field number of this tomb is A54T1.

² The gourd bowl had completely decomposed, but its impression was cast with plaster with the same procedure used in the sub-floor burial of Tomb 2 (see Chapter 5, Note 17).

³ The original field number of this compartment is A54RN.

Chapter 7

TOMB 1

The burial chamber of Tomb 1¹ was located approximately 285 centimeters south of Tomb 2 (Figs 7.1, 7.2). There was no significant erosion in this area, so the burial chamber of Tomb 1 was not made by expanding an eroded pocket, as was done to create the burial chambers of Tomb 2 and Tomb 3. Instead, it was made entirely by breaking adobes out of the recently constructed masonry. Because the tomb was located adjacent to an earlier face of the pyramid, this face became the east wall of the burial chamber, and was smooth and straight. In contrast, the other three sides and floor were irregular.

The burial chamber measured approximately 290 centimeters north-south by 135 centimeters east-west and 140 centimeters deep. Unlike the burial chambers of Tombs A, B, 2, and 3, this burial chamber was not roofed with large beams. It was completely filled with dirt and chunks of broken adobes at the time of the burial. There were two layers of whole adobes, laid without mortar, inside the burial chamber that served to seal it at the top. They were more irregular and more widely spaced than the adobes in the solid masonry and exhibited signs of prior use; it is likely that they had been removed as whole, or nearly whole, adobes when the chamber was created. When we first exposed the tomb, these adobes slumped slightly relative to those around them (Fig. 7.2), but exhibited no deliberate placement like the adobes above Tomb 2 (Fig. 5.5).

Beneath the two layers of adobes inside the burial chamber was a fill consisting of dirt and broken adobes — material that probably also was broken out when the burial chamber was created. In this fill, approximately 70 centimeters below the upper edge of the burial chamber, were two clusters of five ofrendas (Fig. 7.3): one near the northeast corner (Fig. 7.4 C2-C6) and one near the northwest corner (Fig. 7.4 C7-C11). A llama skull, the remains of a textile, and a small jar painted with a white-on-red geometric pattern were also found (Fig. 7.4 C6, Fig. 7.5).² Beneath these objects there were more dirt and chunks of broken adobe.

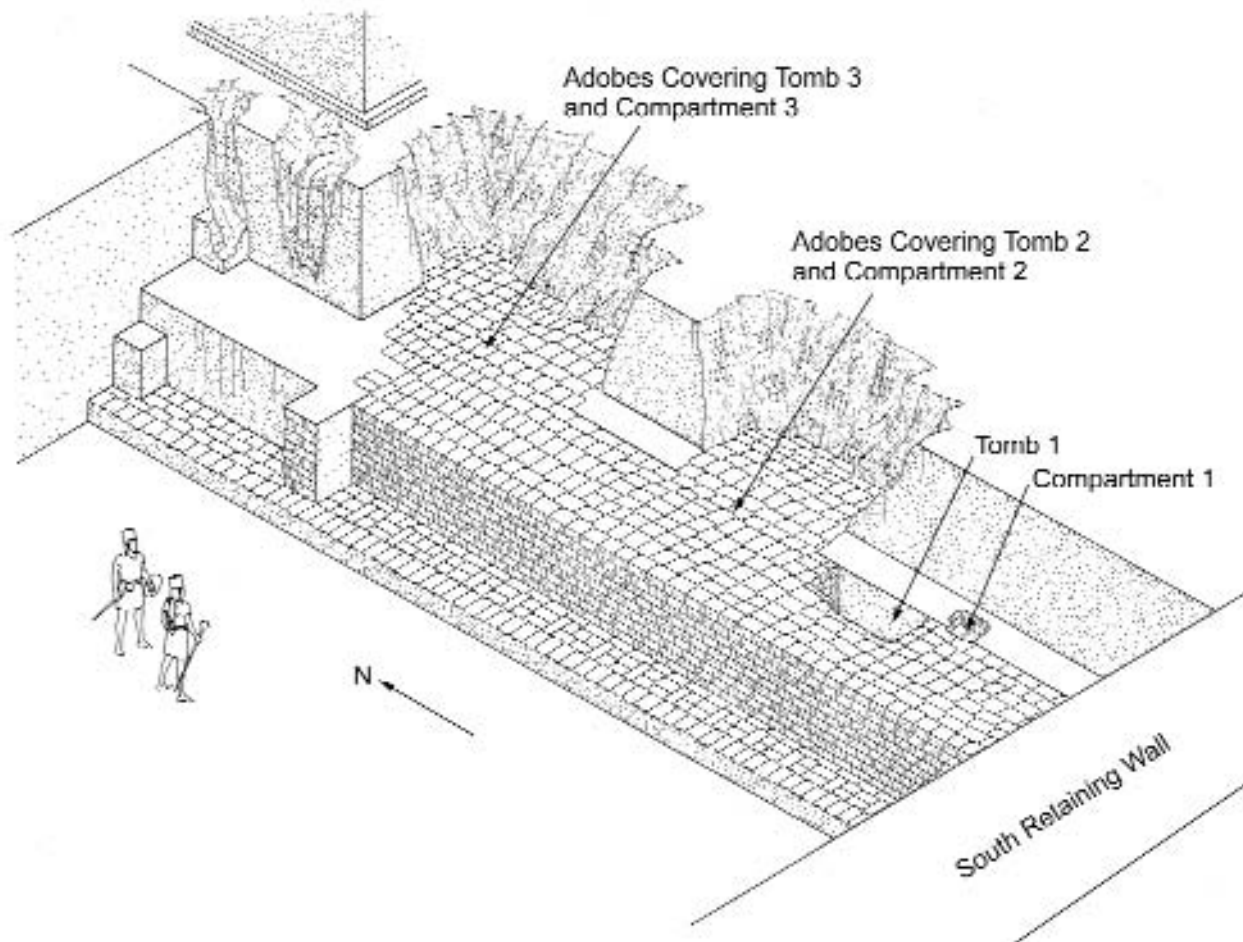

Figure 7.1 STAGE 11: When the successive layers of adobes in the newly constructed masonry reached a height of 1 meter above Tombs 2 and 3, the burial chamber of Tomb 1 and Compartment 1 were constructed.



Figure 7.2 Adobes slumping above the burial chamber of Tomb 1.



Figure 7.3 Objects (pedestaled) in the fill of the burial chamber.

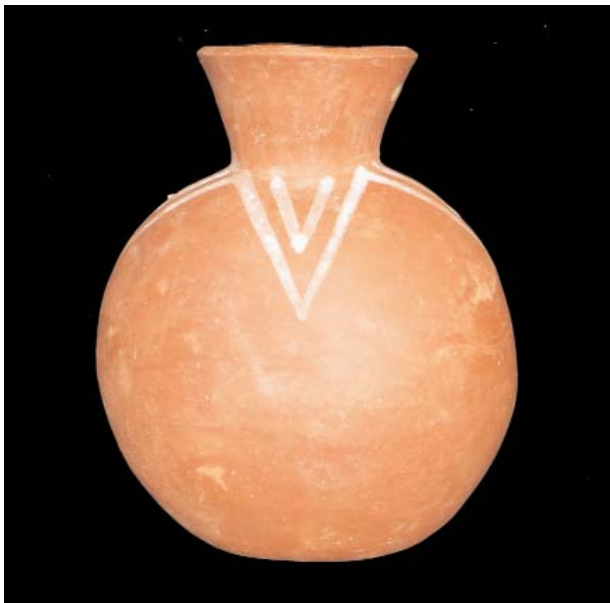

Figure 7.5 Jar C6 (height 12.5 cm).

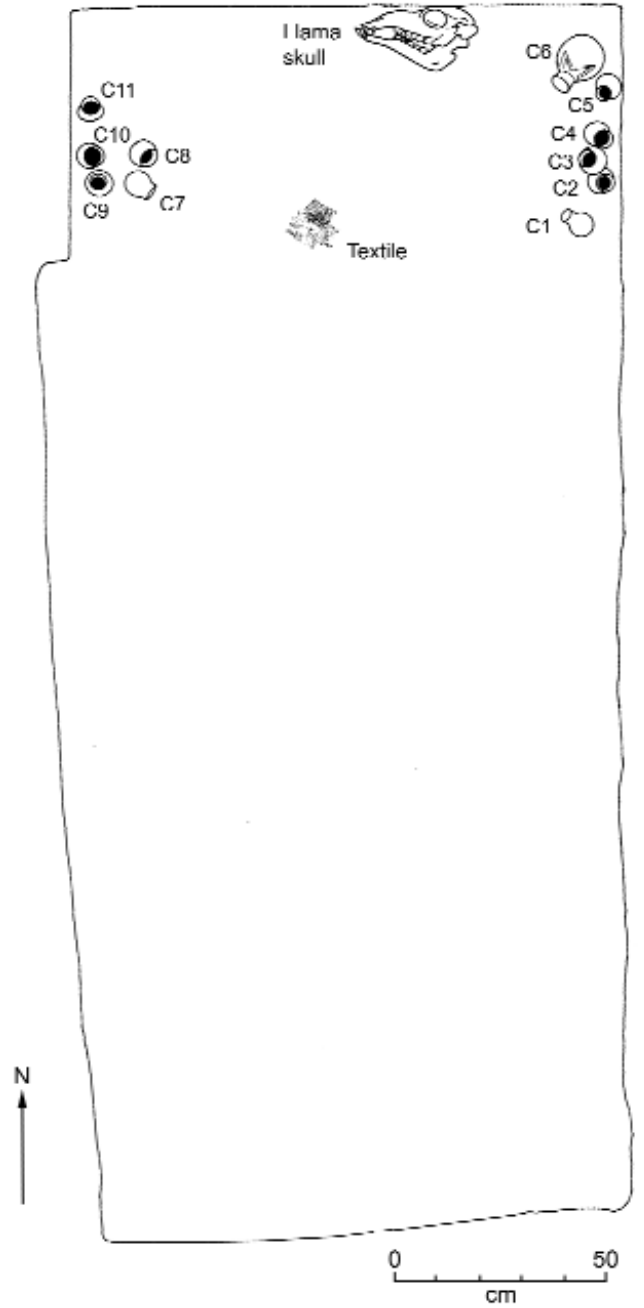

Figure 7.4 Plan of Tomb 1 showing the objects found in the fill of the burial chamber.

On the floor of the burial chamber were two individuals: a male lying in an extended position with his head to the south and a female lying cross-wise at his feet (Figs. 7.6, 7.7). She was approximately 15 when she died and appeared to have been in good health and of normal stature. There were no



Figure 7.6 The floor of Tomb 1 with its contents.

signs of violent death. There was no evidence that she had been dressed at the time of burial, or wrapped in textiles or matting. The only artifacts associated with her were two spindle whorls in front of her left hand (Fig. 7.8).

In contrast, the male had been wrapped, first in multiple layers of tex-

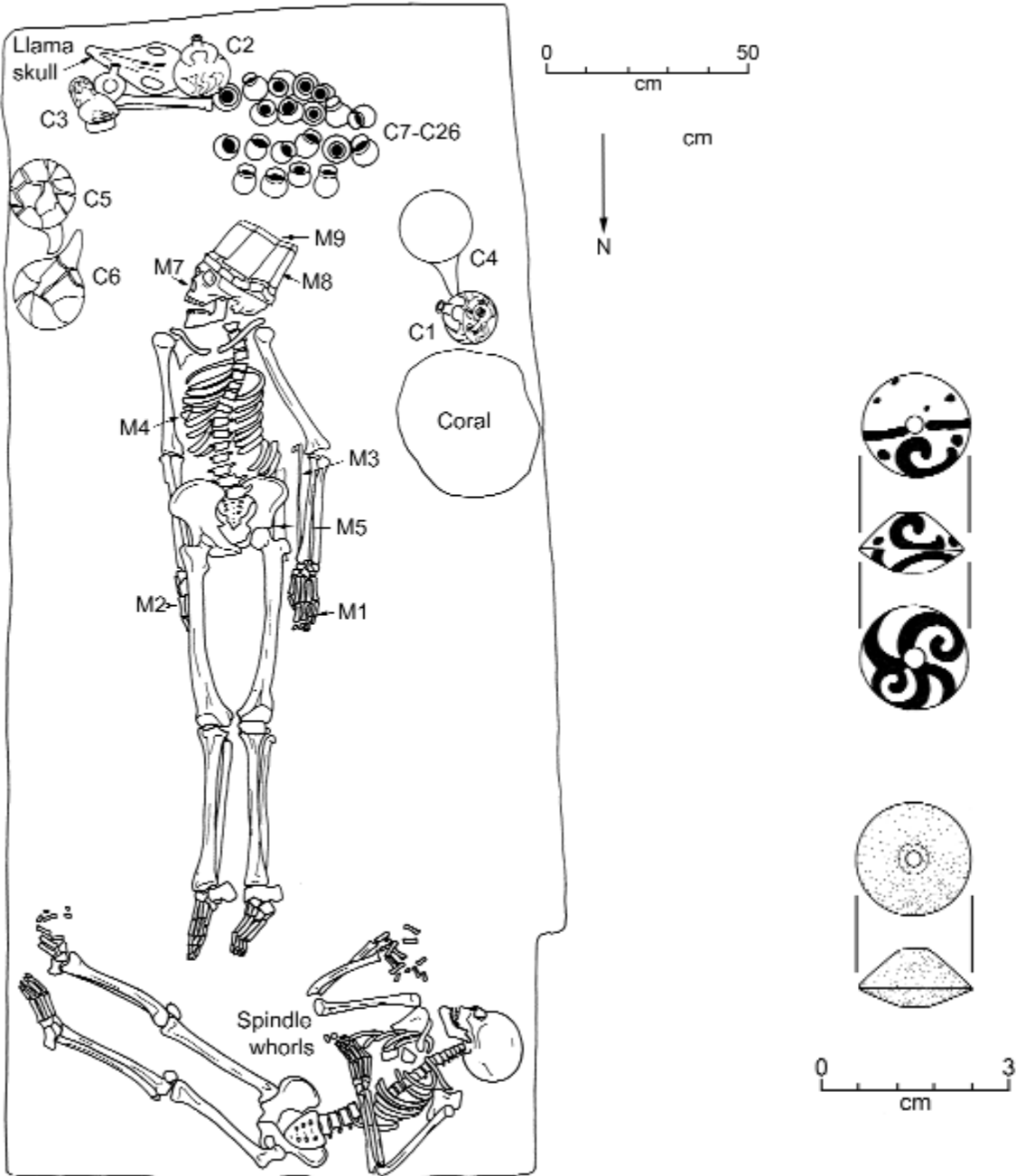

Figure 7.7 Plan of the floor of Tomb 1 with its contents.

Figure 7.8 Spindle whorls associated with the female in Tomb 1.

tiles,³ then with a mat,⁴ and finally in a tube made of lengths of cane.⁵ The textiles, matting, and cane had almost completely decomposed, but the traces that remained clearly indicated that the man had been buried in a large funerary bundle, which was placed on the center of the floor.

As in the other two tombs, many objects had been wrapped inside the bundle. Wool yarn was wound multiple times around both of the man's wrists. His palms were down, and each was resting on a copper nose ornament (Fig. 7.7 M1, M2, Fig. 7.9). These nose ornaments appeared to be the same in size and form, although the one under his right hand was badly corroded and had shattered into many pieces. The one under his left hand was also corroded, but it was possible to remove it intact. It was oval shaped and slightly round-



Figure 7.9 Copper nose ornament (M1) under the individual's left hand. Note the traces of wool yarn adjacent to the wrist.

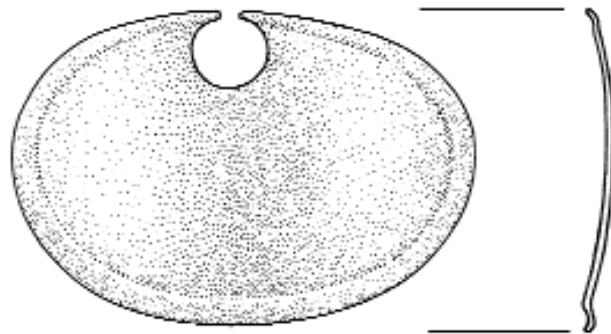

Figure 7.10 Copper nose ornament M1 (height 4.5 cm).



Figure 7.11 Copper engaging spur for a spear thrower M9 (height 2.7cm).

ed in cross section (Fig. 7.10). Both nose ornaments were lying front side up and positioned so that the portion that is put through the nose was oriented in the direction of the individual's head.

There was a spear thrower under his left arm (Fig. 7.7 M3), recognizable from the copper engaging spur (Fig. 7.11) and the impression in the soil of what was probably a wooden shaft that measured approximately 42 centimeters in length and 2 centimeters in diameter. On the right side of his chest were small copper tweezers (Fig. 7.7 M4, Fig. 7.12). Along the left side of his body was a large copper chisel (Fig. 7.7 M5, Figs. 7.13, 7.14).⁶ In the individual's mouth was piece of sheet metal that had blue oxidation, suggesting that it contained silver.

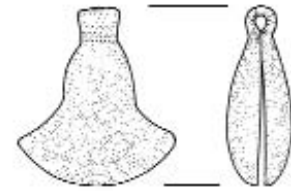

Figure 7.12 Tweezers M4 (height 2.9 cm).



Figure 7.13 Torso of the individual showing the tweezers (M4, upper left), and the chisel (M5, right).

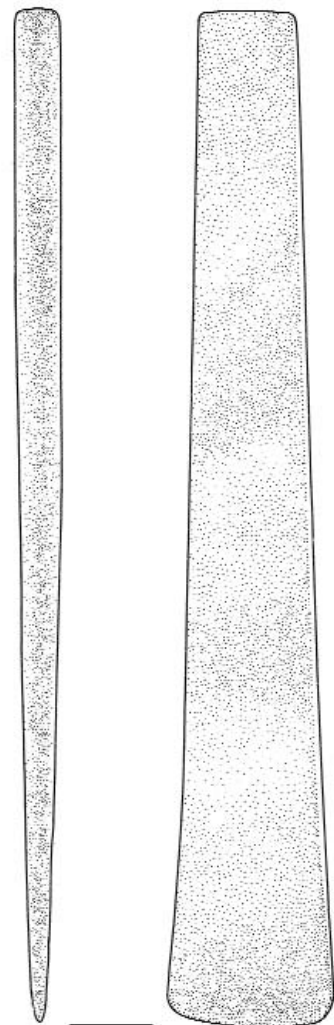

Figure 7.14 Chisel M5 (height 22.5 cm).

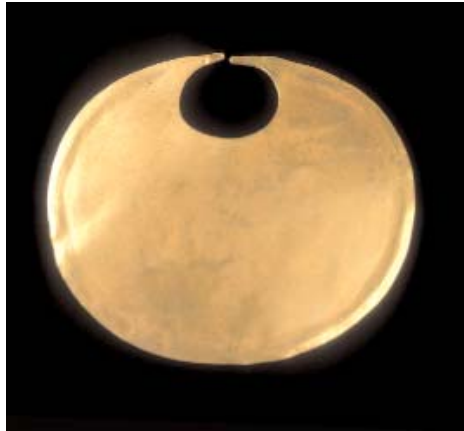

Figure 7.15 Gold nose ornament M7 (height 3.1 cm).

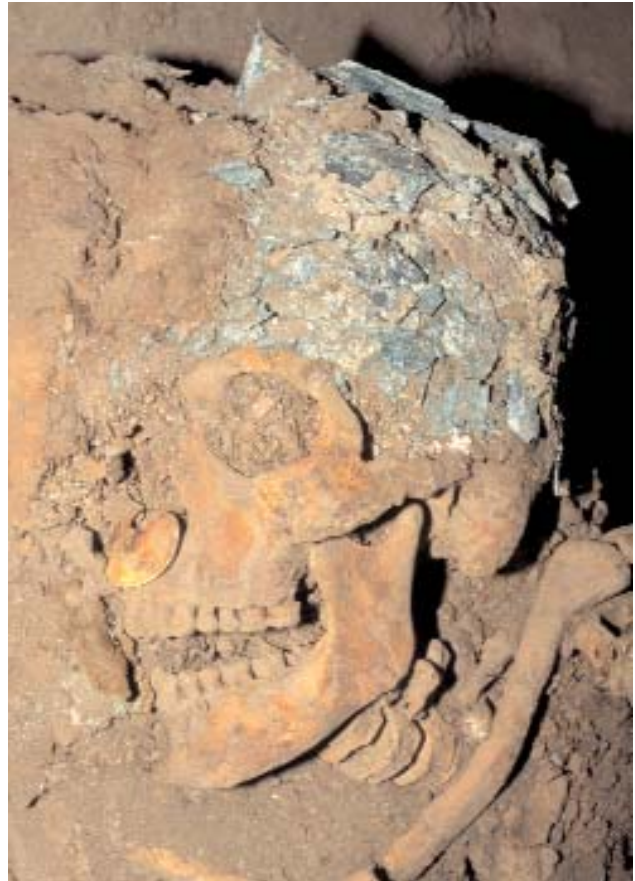

Figure 7.16 The individual with a gold nose ornament (M7) and a gilded copper headdress (M8). Note the red pigment on the bones of the face.



Figure 7.17 Reconstructed platelet from Headdress M8, after cleaning (height 12.3 cm).

There was a gold nose ornament in front of the man's face (Fig. 7.7 M7, Fig. 7.15) which he appeared to have been wearing at the time of his burial (Fig. 7.16). He was also wearing an elaborate headdress similar to many that were found in Tomb 2 and Tomb 3 (Figs. 7.16–7.18). It was made of a basketry cylinder covered with textile, to which gilded copper platelets were sewn. All the decorated platelets had the same design — the head of a supernatural creature resting directly on a pair of legs (Figs. 7.17, 7.18). The creature appears to be a Crested Animal, identi-

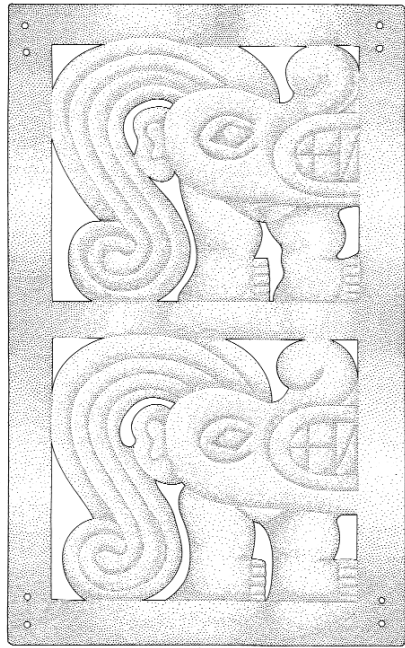

Figure 7.18 Headdress M8. Left, one of the platelets (height 12.3 cm). Right, original appearance of the headdress.

fiable by its distinctive large crest spiraling back from the top of its head and a smaller crest spiraling over its snout. This design, bordered with a rectangular frame, was repeated in an upper and lower register on each of the vertical platelets.

Rolled up under the cylindrical headdress was a large crescent-shaped headdress ornament of gilded copper (Fig. 7.19). It did not have any holes for attaching it to a headdress or a pin similar to those on the crescent-shaped headdress ornaments in Tomb 2 (Figs. 5.38, 5.46), and thus it does not appear to have been functional.

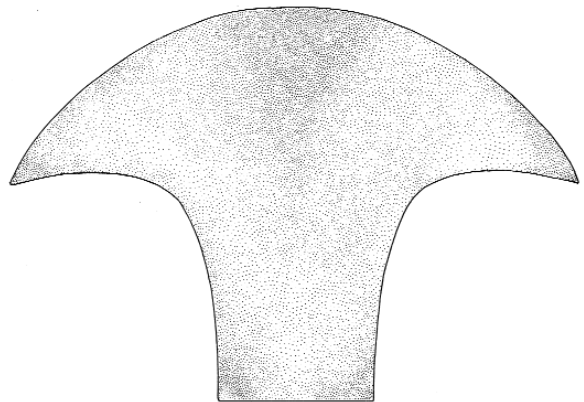

Figure 7.19 Crescent-shaped headdress ornament M9 (height 24 cm).



Figure 7.20 The south end of Tomb 1.



Figure 7.21 Dipper C4 (length 26.7 cm).

Outside the funerary bundle were many objects that had been placed near the walls at the south end of the tomb, surrounding the man's head and torso (Figs. 7.6, 7.7, 7.20). Near the west wall were a large boulder of coral, a ceramic dipper (Fig. 7.7 C4, Fig. 7.21), and a sculpted and painted stirrup spout bottle with an undulating serpent modeled in low relief on its chamber (Fig. 7.7 C1, Fig. 7.22). Along the south wall were the skull and lower legs of a llama, and two more sculpted and painted stirrup spout bottles depicting birds (Fig. 7.7 C2, C3, Figs. 7.23, 7.24). Also near the south wall was a cluster of 20 ofrendas, positioned in two groups of ten (Fig. 7.7 C7–C26). Finally, along the east wall were two more ceramic dippers (Fig. 7.7 C5, C6, Figs. 7.25, 7.26).

The male in this tomb was approximately 21 when he died. He had

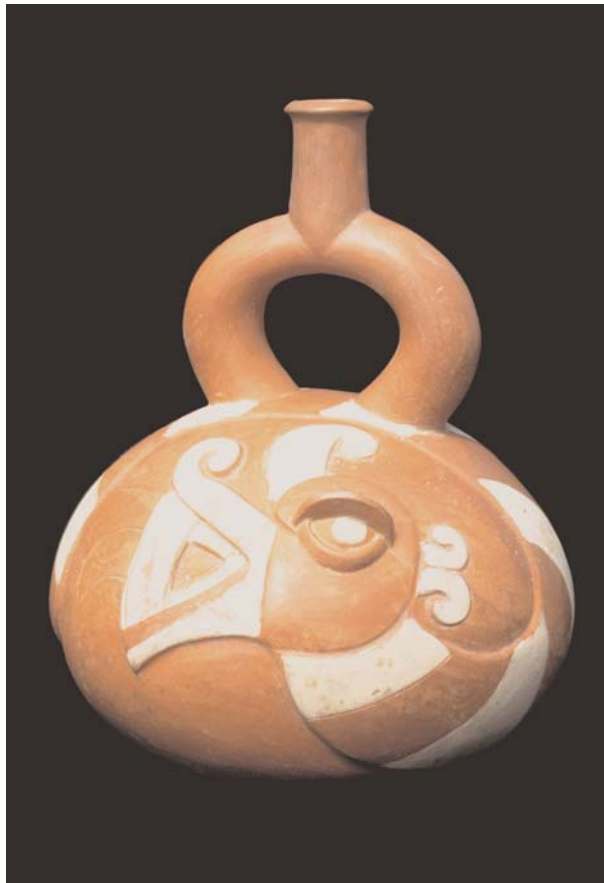

Figure 7.22 Undulating serpent C1 (height 19 cm).

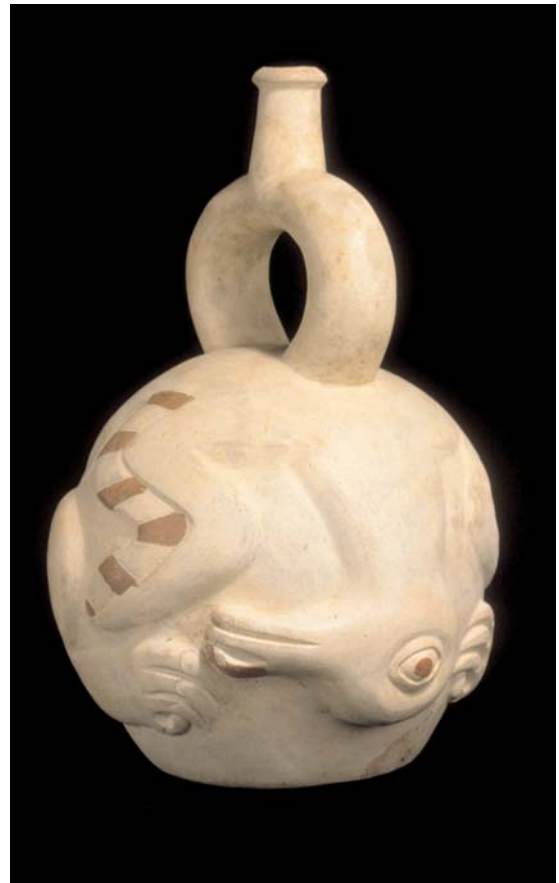

Figure 7.23 Bird C2 (height 21.5 cm).

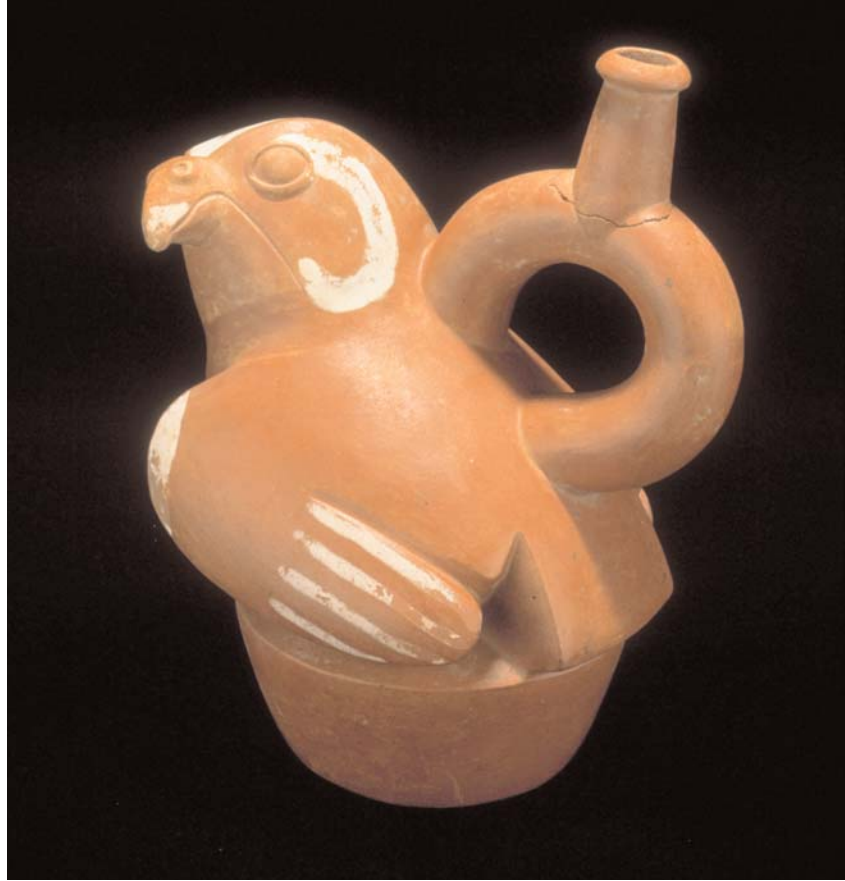

Figure 7.24 Bird C3 (height 18.9 cm).



Figure 7.25 Dipper C5 (length 26.5 cm).



Figure 7.26 Dipper C6 (length 28.2 cm).

extensive arthritic lipping along his vertebral column and at the ends of his long bones.⁷ He also had extraordinarily long legs and long arms, big hands, and a massive skull. His stature, calculated from the length of his long bones, was approximately 183 centimeters. Like the individuals in Tombs A, 2, and 3, he was extremely tall relative to other Moche males.

COMPARTMENT 1

Approximately 20 centimeters south of the burial chamber of Tomb 1 there was a small rectangular compartment⁸ filled with dirt and broken adobe, similar to the compartments adjacent to Tomb 2 and Tomb 3 (Figs. 5.130, 6.31). It was approximately 112 centimeters north-south, 71 centimeters east-west, and 30 centimeters deep (Figs 7.27, 7.28). Since it had been created by breaking out adobes from the solid masonry construction of the pyramid, its



Figure 7.27 The floor of Compartment 1.

interior walls and floor were irregular. Its upper edge was at the same level as the upper edge of Tomb 1.

Near the floor of the compartment was a blackware ceramic vessel (Fig. 7.28 C1). It had been broken by the compression of the soil above it, but it could be reconstructed (Fig. 7.29). It is a double-chambered whistling bottle with a sea lion on one of the chambers. The eyes of the sea lion are inlaid with Spondylus shell.⁹ Traces of organic material overlapped the north chamber of this vessel and spread over about half of the compartment. It was light ochre color and may have been the remains of decomposed skin or leather.

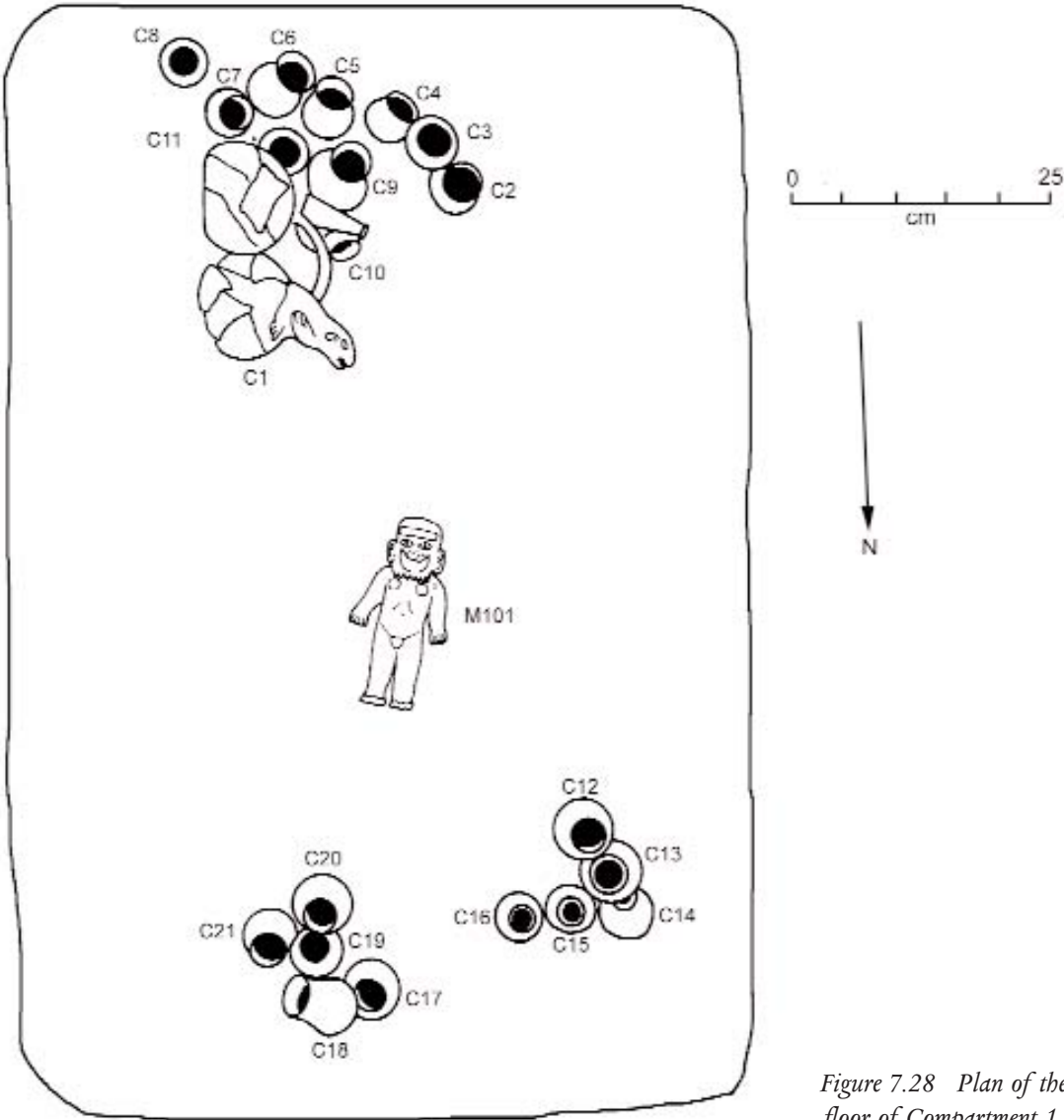

Figure 7.28 Plan of the floor of Compartment 1.



Figure 7.29 Double-chambered whistling bottle with a sea lion C1 (height 17 cm).



Figure 7.30 Copper figure M101 in situ.

On the floor of the compartment there were ten ofrendas along its north side, arranged in two clusters of five (Fig. 7.28 C12–C16 and C17–C21). Along its south side, and partially beneath the double-chambered whistling bottle, was another cluster of ten ofrendas (Fig. 7.28 C2–C11).

There was a bundle of badly decomposed textiles near the center of the compartment. Inside it was a copper figure made of sheet metal, very similar to the copper figures found on the roof of Tomb A and in the compartments of Tombs 2 and 3. Like the copper figures in those compartments, the figure was lying on its back with its head to the south (Fig. 7.28 M101, Fig. 7.30).

A dark organic liquid had been poured over the upper part of nearly the entire compartment, flowing down around the ceramic vessels and between chunks of clay in the fill. It had puddled on the floor in some places.

Like the compartments associated with Tombs 2 and 3, Compartment 1 was almost certainly created as a miniature version of Tomb 1, and the small copper figure in Compartment 1 (Fig. 7.30, 7.31) appeared to be a miniature version of the tomb's principal occupant.



Figure 7.31 Copper figure M101 after cleaning (height 17.9 cm).

When the funerary ritual of Tomb 1 and Compartment 1 was completed, the Moche people once again resumed construction on the west face of the pyramid. This is Stage 12 (Fig. 7.32) in our construction sequence. It

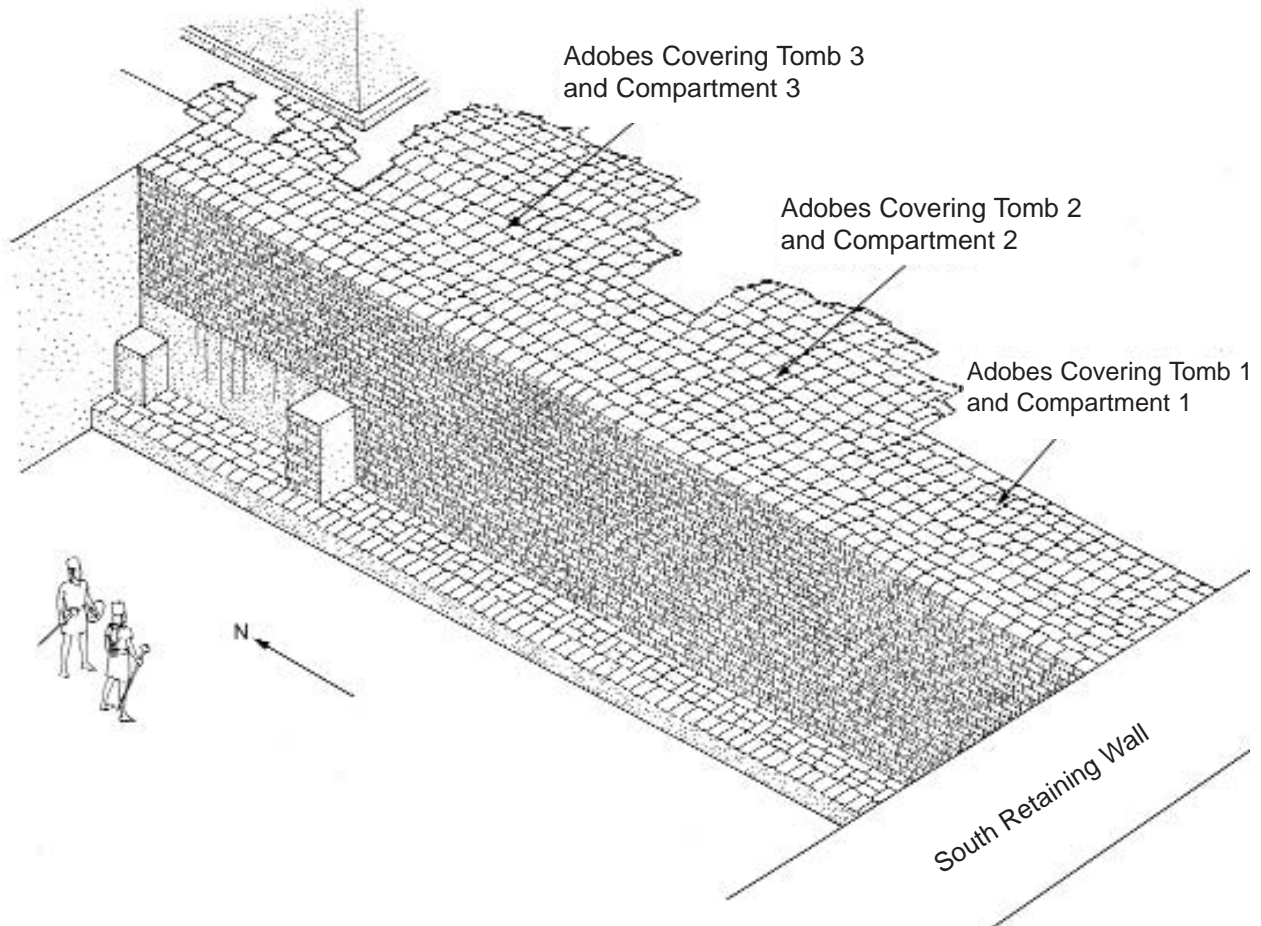

Figure 7.32 STAGE 12 (early): Successive layers of adobes were added above the three tombs and their compartments.

began by adding successive layers of adobes above the three tombs and their compartments, meanwhile filling the deep erosion channels that had been cut into the pyramid during Stage 8 (Fig. 4.21).

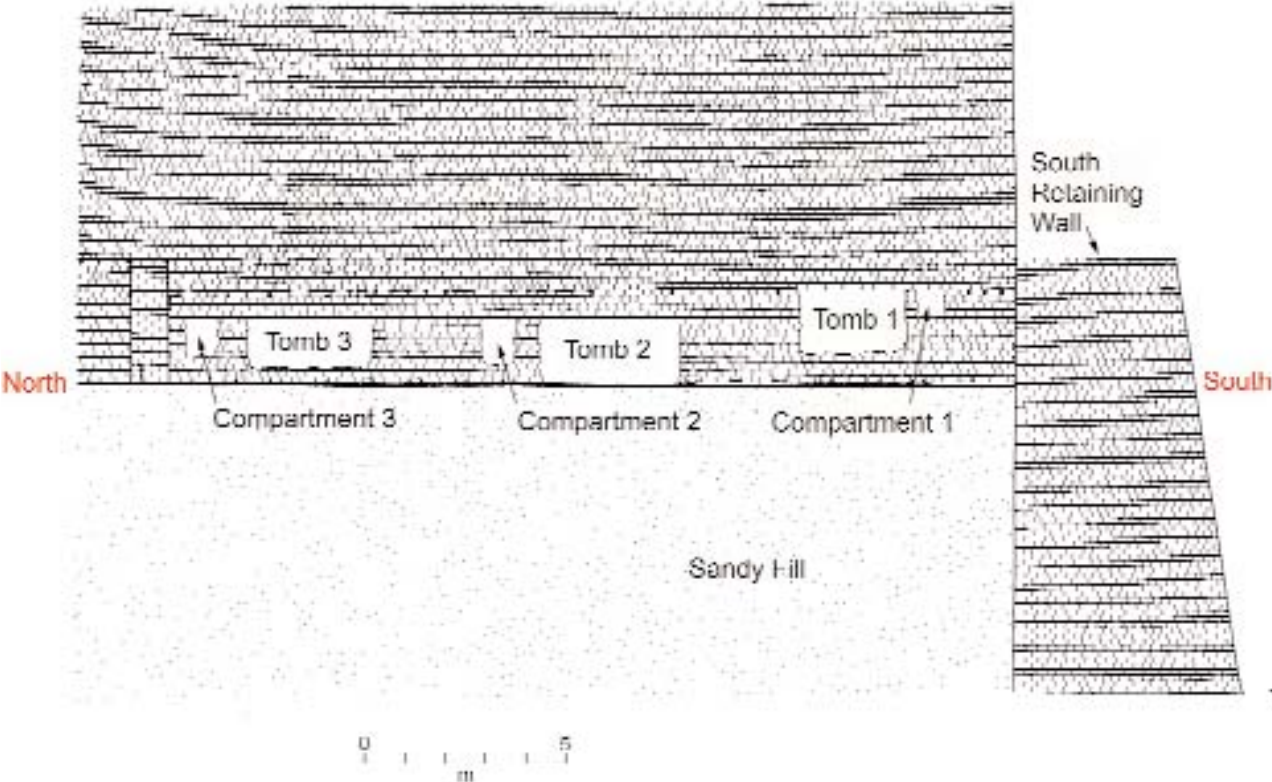

Figure 7.33 STAGE 12 (early): North-south profile as indicated in Fig. 4.6, showing successive layers of adobes that were added above the three tombs and their compartments.

Layers of adobes were added above the tombs and compartments until the new construction achieved a height of at least 10 meters. Then it was coated with clay plaster (Fig 7.33).

During the final stage of construction, Stage 13, adobes were added to raise the height of the low bench that extended along the base of the west face of the pyramid (Fig. 7.34). This encapsulated the two low pillars that were on top of the bench and created a new west face for the pyramid that

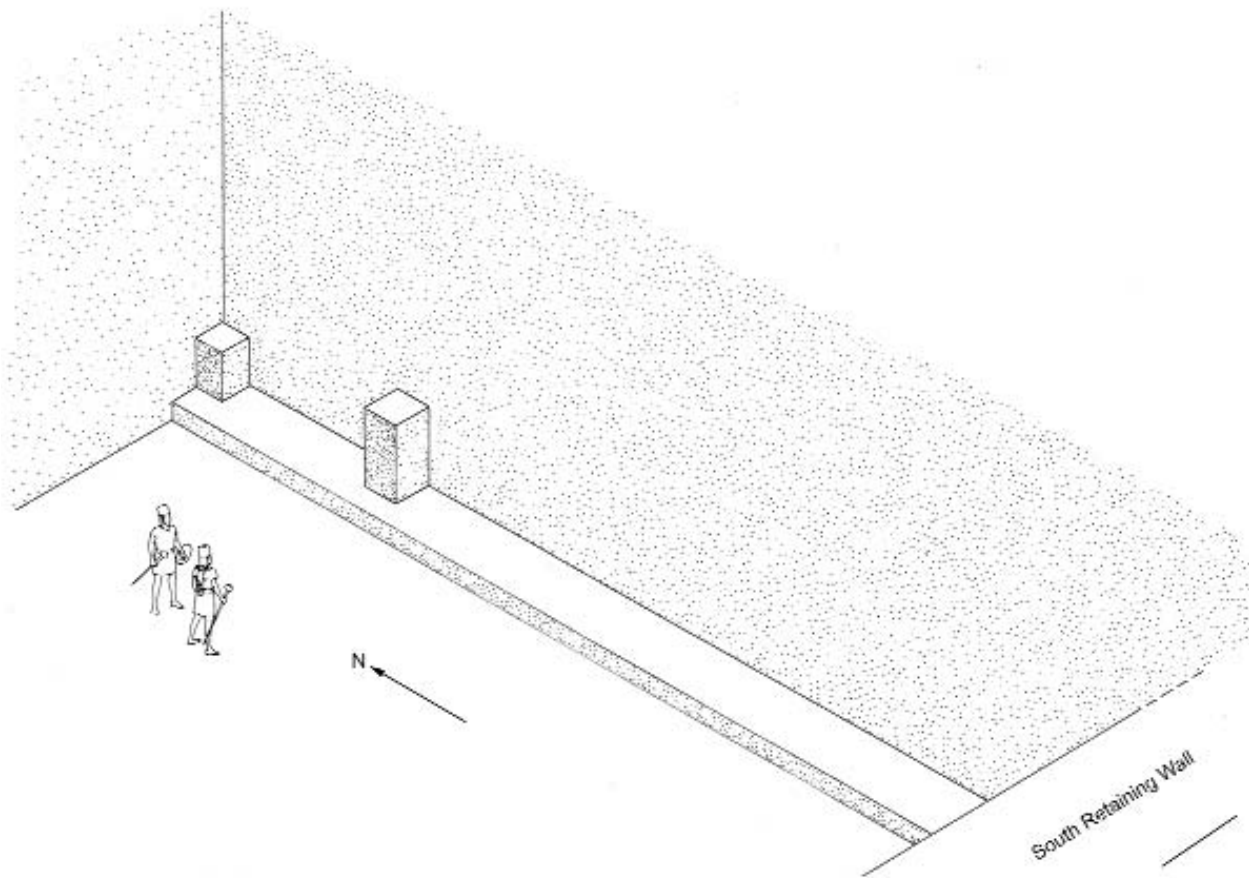

Figure 7.33 STAGE 12 (late): The new construction reached a height of at least 10 meters and then was plastered with clay.

had a high step-back. This new construction was subsequently plastered with clay.

Tombs 1, 2, and 3 and their associated compartments were thus sealed within the solid adobe masonry that formed the bulk of the pyramid. Since this masonry was built out over the earlier sand-filled platform, it effectively sealed the earlier tombs that had been built in the sandy fill, including both Tombs A and B.

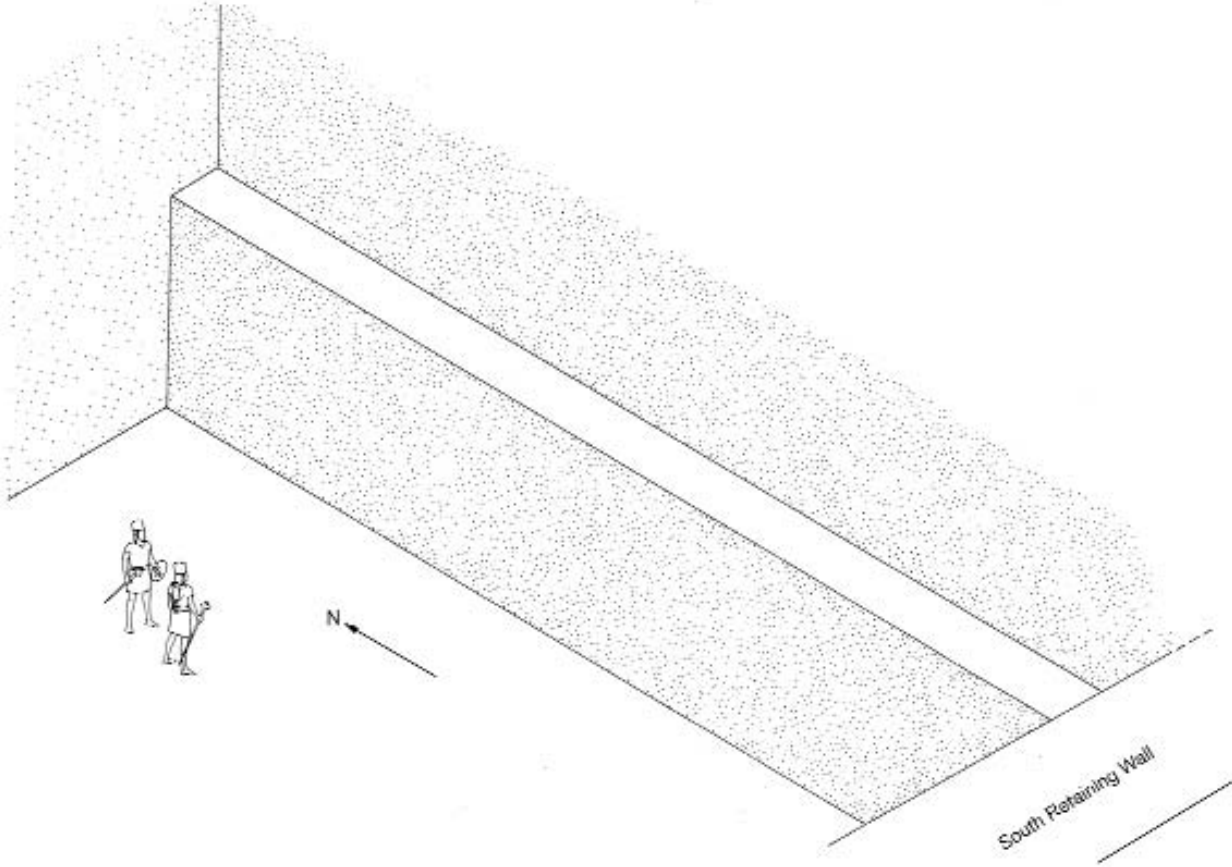

Figure 7.34 STAGE 13: Adobes were added to raise the height of the low bench along the west face of the pyramid and convert it into a high step-back.

NOTES

¹ The original field number of this tomb is A52T1.

² This jar is very similar in form and decoration to the jar found on the roof of Tomb A (Fig. 2.5), but it is smaller and the chamber is flask-shaped.

³ At least two of the textiles were plain weave, with single warps and wefts. The inner one was finer than the outer one.

⁴ The mat was made of junco grass (*Juncus* sp.), with a herringbone twill pattern.

⁵ The cane used appears to have been cana brava (*Gynerium sagittatum*). Wrapping the body in a cane tube is a type of Moche burial practice that is described in Donnan and McClelland, 1997.

⁶ It is similar to the large copper chisel found in Tomb 2 (Fig. 5.96) but is smaller and weighs 443 grams rather than 859 grams.

⁷ Since this normally occurs with Moche individuals who are more than 40 years of age, we first suspected that he must have been at least that old at the time of his death. Only later did we realize that he was much younger.

⁸ The original field number of this compartment is A52R1.

⁹ This vessel is very similar to the double-chambered whistling bottle found in the northeast corner of Tomb 2 (Fig. 5.122), but the eyes on that vessel are not inlaid with *Spondylus* shell.

Chapter 8

OBSERVATIONS AND CONCLUSIONS

The five tombs at the southwest corner of Huaca Dos Cabezas were created in two distinct time periods, which will be referred to as Early Period and Late Period. Tomb A and Tomb B pertain to the Early Period, when tombs were dug into the sandy fill of the platform, beneath the solid adobe masonry that was constructed at a later date to extend the west face of the pyramid. Their burial chambers were constructed in the same way as the other Early Period burial chambers that had been looted in this area before 1994 and are almost certainly contemporary with them. It is not possible, however, to seriate the tombs in this area or to determine whether Tomb A is earlier or later than Tomb B. Nor is it possible to determine whether the Early Period cemetery was in use over a short or long period of time.

Most, if not all, of the material we collected while cleaning around the the remains of looted Early Period tombs probably came from those tombs. It is possible, however, that the looters found some Late Period tombs in the solid adobe pyramid that was built on top of the sand-filled platform, and that some of material from the Late Period tombs was mixed with the material looted from the Early Period tombs.

Sometime before Tomb A and Tomb B were covered over by the construction of the large room with bins (before Stage 3 in the construction sequence; see Chapter 4), they were reentered through a hole in their west perimeter walls. Their contents were removed and partially replaced without

disturbing the material on their roofs. This reentry appears to have been ceremonial in nature.

Unfortunately, we could not determine in most cases whether other Early Period tombs were also reentered. However, the perimeter wall of one looted tomb was complete, with no sign of reentry. Therefore, if the tombs were consistently reentered by opening a hole in their perimeter wall, this tomb was not reentered.

The three Late Period Tombs, Tombs 1, 2, and 3, were in the solid adobe masonry of the pyramid. Of the three, Tomb 2 contained a much higher quantity of associated objects than Tomb 1 and Tomb 3 — in fact, higher than the quantity of objects in both of these tombs combined. The compartment of Tomb 2 also had a higher quantity of associated material than the compartments of Tomb 1 and Tomb 3 combined. It is not known why Tomb 2 was so much richer than the other two tombs; however, it is noteworthy that Tomb 2 is positioned between the other two, as though it was the most important and Tomb 1 and Tomb 3 were lesser tombs placed to flank it. It is interesting that Compartment 1 was at the south end of Tomb 1, while Compartment 3 was at the north end of Tomb 3. Perhaps this was to locate the burial chambers of Tombs 1 and 3 on the inside of the cluster, close to Tomb 2, and locate their compartments on the outside of the cluster.

The alignment of the three tombs along a north-south axis was probably deliberate, although to some extent it was due to circumstances of the new construction to expand the west face of the pyramid. The pockets of erosion that resulted from heavy rainfall during Stage 8 in the construction sequence (Figs. 4.20, 4.21) appear to have dictated the positions of Tombs 2 and 3, whose burial chambers were made by simply enlarging the erosion pockets.

Tomb 1, however, was made entirely by breaking adobes out of the recently constructed masonry. Thus it could have been located almost anywhere in the new masonry — even west of either Tomb 2 or Tomb 3. Yet it was located along the same north-south axis as the other tombs, again suggesting that the three tombs were intended to form a single set, with Tomb 3 flanking Tomb 2 on the north and Tomb 1 flanking Tomb 2 on the south.

DIFFERENCES IN THE LATE PERIOD TOMBS

Although Tombs 1, 2, and 3 have many features in common, they also have significant differences. Among the most important are the extent to which the tomb chambers were filled and the presence or absence of roof beams. The burial chamber of Tomb 1 was almost completely filled with dirt and chunks of adobes and then sealed with two layers of adobes. It had no roof beams and was left with no open space inside the chamber. Tomb 2 was roofed with wooden beams and had no fill. Thus its entire burial chamber would have been open space. Tomb 3 was roofed with wooden beams but its burial chamber was filled halfway to the roof, thus leaving only half of the chamber open.

The roof beams are different in Tombs 2 and 3. In Tomb 2, ten large beams extended north-south, with their ends resting on the upper edge of the funerary chamber. There were also four east-west beams, with their west ends resting on the upper edge of the funerary chamber and their east ends socketed into holes cut into the old west face of the pyramid.

In contrast, Tomb 3 did not have beams extending north-south; all ten beams extended east-west. Furthermore, although the west ends of the beams were resting on the upper edge of the funerary chamber, the east ends were supported by a beam resting on two posts instead of being socketed into holes cut into the old west face of the pyramid.

The differences in the quantity of fill in the three tombs and in the way the roof beams were used in Tomb 1 and Tomb 2 suggest that each of the three tombs was built independently and not by the same individuals. There may even have been a deliberate effort to make each tomb unique.

LATE PERIOD COMPARTMENTS MIMIC ASSOCIATED TOMBS

The selection of objects in the compartments as well as their quantity and quality closely reflect the contents of their associated tomb chambers. Tomb 2, for example, contained the highest number of elaborately sculpted ceramic vessels (eight), and its compartment also contained the highest number (four). Tomb 1 contained the second highest number of elaborately sculpted

ceramic vessels (three), and its compartment contained the second highest (one). Tomb 3 contained the lowest number of elaborately sculpted ceramic vessels (two), and there were none in its compartment.

The same occurred with headdresses. Tomb 2 had the highest number of headdresses in its burial chamber (14), and its compartment also had the highest number (four full-sized and two miniature). Tomb 3 had the second highest number of headdresses in its funerary chamber (3) and the second highest number in its compartment (one miniature). Tomb 1 had the lowest number of headdresses (one), and there were no headdresses in its compartment.

The same occurred with nose ornaments. Tomb 2 and Tomb 3 had numerous nose ornaments in their burial chambers and several miniature nose ornaments associated with the copper figures in their compartments. Tomb 1, however, had fewer nose ornaments in its burial chamber, and only one nose ornament associated with the copper figure in its compartment.

The fact that the number of elaborate ceramic vessels, headdresses, and nose ornaments in the three burial chambers is roughly proportional to the number of these objects in the associated compartments suggests that the compartments were intended to be miniature versions of their adjacent burial chambers. This is most clearly demonstrated by the number and variety of objects in the burial chamber and compartment of Tomb 2 compared with the number and variety of objects in the burial chambers and compartments of Tombs 1 and 3.

DELIBERATE SIZING OF THE TOMBS AND COMPARTMENTS

The size of the funerary chambers and the compartments appears to have been determined by the quantity of material that was to be placed inside them. The funerary chamber of Tomb 2 was made larger than the funerary chambers of Tombs 1 and 3, probably to accommodate the more elaborate funerary bundle of Tomb 2, with its numerous objects inside, as well as the greater number of ceramics and animal remains inside the burial chamber. It may also be that Tomb 2 was made larger because the Moche were already planning to encase the funerary bundle in clay, which would require more

space within the burial chamber.

Similarly, Compartment 2 was made much deeper than either Compartments 1 or 3, seemingly because the objects that were to be placed inside would require greater volume. Compartment 2 was 62 centimeters deep, compared with 30 centimeters for Compartment 1 and 40 centimeters for Compartment 3. With greater depth, the contents of Compartment 2 could be arranged in multiple layers rather than in one layer as in Compartments 1 and 3. This suggests that the people who created the burial chambers and the compartments had a clear idea not only of what they would ultimately contain but also of how the contents were going to be placed, and they created the chambers and compartments accordingly.

CONTEMPORANEITY OF THE LATE PERIOD TOMBS

The sequence of architectural remodeling at the southwest corner of Huaca Dos Cabezas provides evidence that Tombs 1, 2, and 3 were all made during a brief period, with Tombs 2 and 3 made first. All three tombs were built in the solid adobe masonry that was constructed to create a new west face of the pyramid. Since the burial chambers of Tombs 2 and 3, as well as their compartments, were all cut from the same level of adobes, they must have been made at the same time, when construction of the solid masonry had reached that height. Moreover, the construction would have continued almost immediately after the funerary rituals for Tombs 2 and 3 ended, or else the female above the roof of Tomb 3 and the female and llama above Tomb 2 would have been left exposed and almost certainly would have been disturbed by vultures and scavaging animals. The fact that their skeletons showed no evidence of disturbance indicates that construction of additional layers of adobes above them must have resumed shortly after the funerary rituals of Tombs 2 and 3 were completed.

Tomb 1 appears to have been created somewhat later than Tombs 2 and 3. The upper edge of its burial chamber is approximately 1 meter higher than the upper edge of Tombs 2 and 3 and could not have been created until the construction of the solid adobe masonry reached that height. How much time would have elapsed to raise the level of the masonry by 1 meter is difficult to

assess. Depending on how many people were working on the construction and the availability of adobes and mortar, it could have been as short as a week. But it seems unlikely that it would have been longer than two months. Thus it is likely that Tombs 1, 2, and 3, and their adjacent compartments, were all created within a period of two months or less.

The contemporaneity of these three tombs is also indicated by various characteristics they had in common. All of the burial chambers and their adjacent compartments had been formed by removal of adobes from the solid adobe masonry of the pyramid. In each tomb the principal individual was lying on his back oriented north-south, with his head toward the south. Each of the three individuals was wrapped in a funerary bundle that contained a variety of objects of gold, silver, and copper. There were ceramics and camelid remains in the corners of each of the burial chambers, mostly at the south end around the head and torso of the principal individual. All three tombs had a compartment at one end, with a copper figure lying on his back with his head to the south.

The similarity of headdresses found in the tombs and their compartments also suggests contemporaneity. Each of the tombs contained at least one cylindrical headdress made with gilded copper platelets — a very unusual type of Moche headdress that had not been previously excavated.

The ceramics from the three Late Period tombs are very similar, again suggesting contemporaneity (see below). This is particularly clear with the double-chambered whistling bottles with sea lions that were found in Compartment 1 (Fig. 7.29) and Tomb 2 (Fig. 5.122). Although the bottle from Compartment 1 has *Spondylus* eyes, the two vessels are nearly identical in all other respects.

Some of the metal objects in the three Late Period tombs also suggest contemporaneity. Each tomb contained a large copper chisel and a spear thrower with a copper engaging spur. The copper figures from the compartments of the three tombs were also very similar in size and form (see below).

A major implication of the contemporaneity of Tombs 1, 2, and 3 is that their principal individuals died at about the same time. One alternative explanation would be that one or two of them died first, and their bodies were kept until the death of the third so the three could be buried together. There is evidence that the Moche sometimes kept corpses for long periods of time before

they were finally buried. In these cases, the soft tissue holding the bones in place decomposed, allowing the bones to fall out of anatomical position when the bodies were moved during burial (Alva and Donnan 1993: 123-125; Nelson 1998). This appears to have been the case with Burial 4 above Tomb B (Fig. 3.9). However, the bones of the principal individuals in Tombs 1, 2, and 3 were not out of anatomical position; thus there is no evidence that they had been kept for any extensive period of time before being placed in their tombs. If the three principal individuals in these tombs died at about the same time, it is not known how or why this occurred.

ABSOLUTE CHRONOLOGY

Five radiocarbon dates were processed from the Dos Cabezas tombs. Three of these were from Early Period tombs: two from Tomb A (Samples 1 and 2) and one from Tomb B (Sample 3). The other two (Samples 4 and 5) were from Tomb 2, a Late Period tomb.

The two radiocarbon samples from Tomb A used fragments of textiles that were wrapped around the copper figure on top of the roof beams. The results are as follows:

Sample 1: Beta-219770

Conventional radiocarbon age: 1570 ± 40 BP

2 Sigma (95% probability): Calibrated AD 410–580

Sample 2: Beta-219771

Conventional radiocarbon age: 1660 ± 40 BP

2 Sigma (95% probability): Calibrated AD 260–290
and AD320–450

The one radiocarbon date from Tomb B was from the burned textiles in the offering above the roof of the tomb. The results are as follows:

Sample 3: Beta-89550

Conventional radiocarbon age: 1540 ± 50 BP

2 Sigma (95% probability): Calibrated AD 420–635

One of the radiocarbon samples from Tomb 2 (Sample 4) was from part of the desiccated brain found in the cranial vault of the principal individual. The other (Sample 5) was from a fragment of textile from the funer-

ary bundle. The results are as follows:

Sample 4: Beta-129542

Conventional radiocarbon age: 1530 ± 60 BP

2 Sigma (95% probability): Calibrated AD 410–645

Sample 5: Beta-129543

Conventional radiocarbon age: 1580 ± 50 BP

2 Sigma (95% probability): Calibrated AD 390–600

Sample 2, because it crosses the calibration curve at two different points, could be either AD 260–290 or AD 320–450. It seems most likely that the latter date is valid since it corresponds most closely to the other four dates from these tombs. Moreover, it corresponds to six other radiocarbon dates that have been run on Moche material from Dos Cabezas, all of which are between AD 340 and 665.

The radiocarbon samples from Tomb A (Samples 1 and 2) suggest that it was built between AD 320 and 580, while the one from Tomb B (Sample 3) suggests that it was built between AD 420 and 645. Presumably this would also be the date range of the other Early Period tombs in the sandy fill that were looted prior to 1994.

The radiocarbon samples from Tomb 2 (Samples 4 and 5) suggest that it dates between AD 390 and 645. Presumably this would also be the date range of the other Late Period tombs (1 and 3) in the adobe pyramid.

The dates for the Early Period tombs (AD 310–635) overlap but seem somewhat earlier than those from the Late Period tombs (AD 390–645). At this portion of the radiocarbon calibration curve, however, there are some inversions, which makes it difficult to compare radiocarbon dates across this time interval. Therefore, we cannot accurately assess how much time elapsed between the Early Period tombs (A and B) and the Late Period tombs (1, 2, and 3). However, given all the construction phases that took place between Early Period and Late Period (see Chapter 4), it must have been several years.

My own thoughts are that the Early Period tombs probably date between AD 475 and 500 and that the Late Period tombs probably date between AD 525 and 550 — a separation of no less than 25 years and no more than 75 years.

CERAMICS

The fineware ceramic vessels associated with these tombs would clearly be assigned to Phase 1 of the chronology of Larco (Larco 1948) and be expected to date between approximately AD 100 and 250. Thus, the date of AD 310–645 based on radiocarbon is surprising. Nevertheless, it correlates with the six other radiocarbon dates run on Moche material from Dos Cabezas, which are between AD 420 and 610 (calibrated). These dates indicate that the ceramic style that looks like Phase 1 of Larco's chronology continued until after AD 400 at Dos Cabezas — contemporary with Phase 4 of Larco's chronology. It is increasingly apparent that Larco's chronology, which is valid for the Southern Moche Region (south of the Pampa de Paijan), cannot be used effectively in the Northern Moche Region (north of the Pampa de Paijan). In the Northern Moche Region, a different ceramic chronology must be developed (Castillo and Donnan 1994).

The most characteristic feature of the elaborate Moche ceramics from Dos Cabezas is the representation of animals, birds, mythical figures, and humans in three-dimensional sculpture and low-relief modeling. This, combined with their well-prepared clays and slips and skillfully controlled firing, reflects remarkable artistic and technological sophistication. Since the Moche ceramic style seen at Dos Cabezas was first excavated archaeologically at the site of La Mina (Narvaez 1994), it is appropriate to name it the La Mina sub-style of Moche ceramics. In addition to Dos Cabezas and La Mina, it has been found in the Jequetepeque Valley at the site of Masanca (Donnan 2006b; Fig. 1.2).

DELIBERATE USE OF NUMBERS AND NUMBER SETS

The types, numbers, and locations of objects in the Dos Cabezas tombs provide evidence that the Moche were deliberately clustering objects in sets of 5, 10, 20, and 40. The tombs also contained some objects that appear to have been deliberately made using these numbers. This evidence for the deliberate and repetitive use of specific numbers implies that the Moche considered these numbers to be significant, perhaps carrying some symbolic importance,

and also appreciated how the numbers could be combined and divided into sets.

In the burial chamber of Tomb 1, approximately 70 centimeters below its upper edge, there were two clusters of five ofrendas — one near the northeast corner of the burial chamber and one near the northwest corner (Fig. 7.4). On the floor of the burial chamber was a cluster of 20 ofrendas that had been arranged in two groups of ten (Fig. 7.7).

On the floor of Compartment 1 there were 20 ofrendas — ten at the south side and ten more at the north side (Fig. 7.28). Those at the north side had been arranged in two clusters of five.

In Tomb 2, immediately above the roof beams, there were 40 adobes, carefully positioned with twenty at the north end separated by a space from 20 at the south end (Figs. 5.4, 5.5). Each set of 20 was arranged in four rows, with five adobes in each — ample indication that the Moche were creating sets of 5, 10, 20, and even 40, and that they appreciated how these sets could be divided into subsets of these numbers.

The layer of 40 adobes rested directly on top of wooden beams that formed the roof of the burial chamber (Figs. 5.6, 5.7). Ten large beams extended north-south. Beneath them were four transverse beams that extended east-west. There was also a short, crooked beam at the southwest corner that seemingly had no structural purpose but may have been placed there to create a total of five east-west beams (Fig. 5.7).

Among the many objects wrapped inside the funerary bundle in Tomb 2 was the necklace of quartz crystal beads. The beads varied in size and form, and may even have been produced by two or more different individuals, yet they had been assembled into a necklace of 40 beads (Fig. 5.67).

The principal individual in Tomb 2 had five gold objects in his mouth (Fig. 5.60). Four of these were nose ornaments, while the fifth was a piece of thin gold foil. It is curious that the four nose ornaments, each of which was beautifully crafted of sheet gold, were put together with a rather unimpressive piece of gold foil. This suggests that having a total of five objects was more important than having all the objects be similar. Among the many objects of gilded copper inside the funerary bundle were two nearly identical headdress ornaments, each consisting of ten plumes (Fig. 5.29).

The objects placed in the corners of the burial chamber of Tomb 2 also

are in sets of 5, 10, and 20. In the northwest corner there was a double-chambered whistling bottle and a cluster of five ofrendas (Fig. 5.121). In the northeast corner there was another cluster five ofrendas, along with five other ceramic vessels — two stirrup spout bottles, two dippers, and another ofrenda (Fig. 5.123). The latter was placed between the stirrup spout bottles and the dippers, apparently in a deliberate effort to make another set of five so that the total number of ceramic vessels in that corner would be ten.

In the southwest corner four ofrendas were clustered with a small ofrenda-size painted jar to make one set of five (Fig. 5.114). A second set of five consisted of two painted jars and two stirrup spout bottles that were combined with a cooking olla. The latter seems out of place in this context, but it serves to complete the second set of five.

In the southeast corner, the cluster of ofrendas again made one set of five (Fig. 110). In addition, there were three ceramic vessels, a llama skull, and a parrot skeleton. If the intent of the people who selected and placed these objects in the southeast corner was indeed to create two sets of five, then the llama head and parrot must have been considered appropriate surrogates for ceramic vessels.

In the upper layer of Compartment 2 there were 20 ofrendas arranged in two groups of ten, one group arranged in a line along the south side of the compartment and the other arranged in a line near the north side (Fig. 5.130).

In Tomb 3, the roof was made of ten beams that extended east-west, just as there were ten beams extending north-south in the roof of Tomb 2. This suggests that this number of beams was deliberately chosen in both cases.

Inside the funerary chamber, however, there was a surprising lack of the use of five, ten, and twenty. Although there were numerous metal objects, including headdresses, nose ornaments, ingots, and a banner, none of these were clustered in sets of these numbers, nor were these numbers used in the way they were used in Tomb 2. There were, for example, nine nose ornaments with this individual, two of which were in the mouth. Also in the mouth were two ingots, thus making a set of four objects rather than five. There were also two clusters of ofrendas, but the cluster near the north end of the burial chamber contained 11, while the cluster near the south contained eight (Fig. 6.7). This is surprising, since the ofrendas in Tombs 1 and 2, as well as the ofren-

das in their associated compartments, were consistently in sets of 5, 10, and 20. These numbers do occur, however, in Compartment 3. On its floor there was one set of ten ofrendas near the south wall, and another set of ten ofrendas near the north wall (Figs. 6.29–6.31).

The use of five and ten can also be seen in Tomb A. Above the roof, there were ten ofrendas at the south end of the tomb and five larger unburnished and unpainted jars, while at the north end there were another ten ofrendas (Fig. 2.3). Furthermore, the roof of the tomb was constructed with five large beams (Fig. 2.9).

These four tombs and their associated compartments provide ample evidence for the deliberate grouping of objects into sets of 5, 10, 20, and 40. They also suggest that the Moche appreciated how sets could be divided into subsets — ten divided into two sets of five, 20 divided into two sets of ten or four sets of five, and 40 divided into two sets of 20 or eight sets of five. These numbers and number sets were most frequently expressed with ofrendas, perhaps because numerous ofrendas were put into the tombs and compartments, while other kinds of objects were often represented by three examples or less.

Other than at Dos Cabezas, the deliberate use of numbers and number sets by the Moche has been observed only in the tombs at Sipán and Loma Negra (Donnan ms.a). No Moche burials from other sites exhibit any attempt to cluster objects in this way. The tombs where such clustering has been found are among the richest Moche tombs ever excavated archaeologically. Perhaps the use of these numbers and number sets was restricted to the upper echelon of Moche society.

The frequent use of 5, 10, 20, and 40 in the Dos Cabezas tombs suggest that these numbers had an important symbolic meaning and were an important way of both perceiving the world and organizing it in a meaningful way.

PRINCIPAL INDIVIDUALS IN THE TOMBS

The principal individual in each of the three Late Period tombs and the individual in Tomb A were all adult males between 18 and 22 years of age who

were unusually tall. While the range of height for Moche males is between 148 and 168 centimeters, with an average of 158 centimeters (Verano 1997:193), these three individuals were between 175 and 180 centimeters, with an average of 177 centimeters (Cordy-Collins 2003). The unusual height of these individuals suggests that they may have been genetically related.

Alana Cordy-Collins has conducted an extensive study of the skeletons of the individuals and has observed they all exhibit skeletal abnormalities, some shared and others unique. Bones that are longer, larger, or lighter in one individual are not necessarily ones that are longer, larger, or lighter in the others. Moreover, there is little bilateral symmetry of the weight of any single individual's paired bones.

Her analysis further indicates that during their development, all of the principal individuals in these tombs suffered periods of stress; radiographs and direct observations reveal several Harris lines in the long bones, especially in the tibiae. There are many possible causes for Harris lines, and it is not possible to identify the cause of a given line or the duration of the condition that caused it. Nevertheless, because Harris lines disappear with age, their presence suggests that these individuals were in a period of growth when they died, and that the lines had been laid down recently. The bones of all of the individuals appear to have been growing, aging, and deteriorating rapidly.

Analysis of the skeletons of other Moche people living at Dos Cabezas indicates that the agents responsible for the tall stature and bone abnormalities of the principal individuals in these tombs were not shared with the population at large. The fact that the abnormalities are present in one of the Early Period tombs (Tomb A) as well as in the Late Period tombs strongly suggests that it was a hereditary condition.

COPPER FIGURES

Very few Moche sheet metal figures had been found before these tombs were excavated at Dos Cabezas. Two were looted from the site of Loma Negra in the Piura Valley in the 1960s. These two are only about 9 centimeters high. Each is fully dressed and has an elaborate headdress. Each apparently had a



Figure 9.1 Copper figures from the tombs: A from Tomb A, 1 from Tomb 1, 2 from Tomb 2, and 3 from Tomb 3.

shield strapped to the left wrist and a war club in the right hand. A large hook on their backs suggests that they were meant to be suspended.

Three other sheet metal figures were excavated in the royal tombs at Sipán. Two of these were parts of elaborate gold and turquoise ear ornaments (Alva and Donnan 1993:Figs. 86, 87), while the third was part of a nose ornament (*ibid*:Fig. 219). All three of these figures are between 6 and 8 centimeters high, and, like the Loma Negra figures, are fully dressed and have elaborate headdresses. Each has a shield on one wrist and holds a war club in the other hand.

The metal figures in the tombs at Dos Cabezas are considerably larger than those from Loma Negra and Sipán: they range between 15 and 18 centimeters in height (Figs. 9.1–9.5). Moreover, they are not parts of nose or ear ornaments, nor were they suspended from a hook. They do not wear clothing; what appears to be a loincloth on two of them is actually a sheet of gilded copper shaped to represent the genitals. They are essentially nude, but at the time they were put into their compartments they may have been wearing clothing made of perishable material.

Although the four copper figures are very similar in size and form, care-

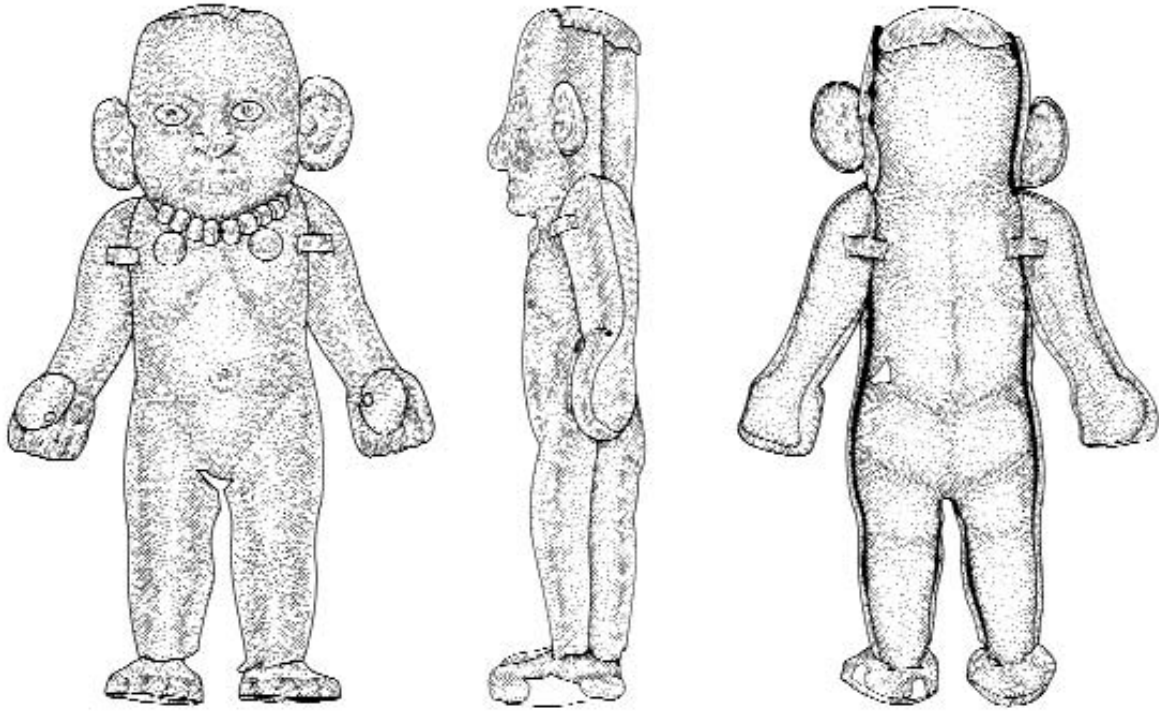

Figure 9.2 Copper figure A, from Tomb A (height 15.7 cm).

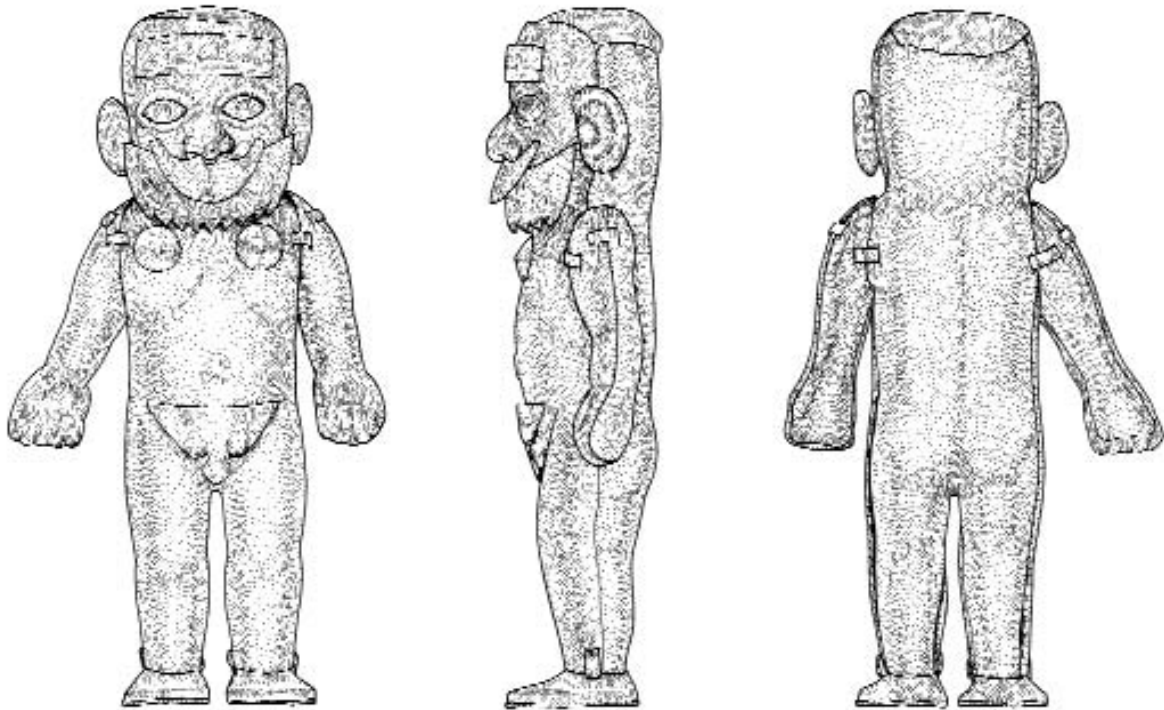

Figure 9.3 Copper figure 1, from Tomb 1 (height 16.1 cm).

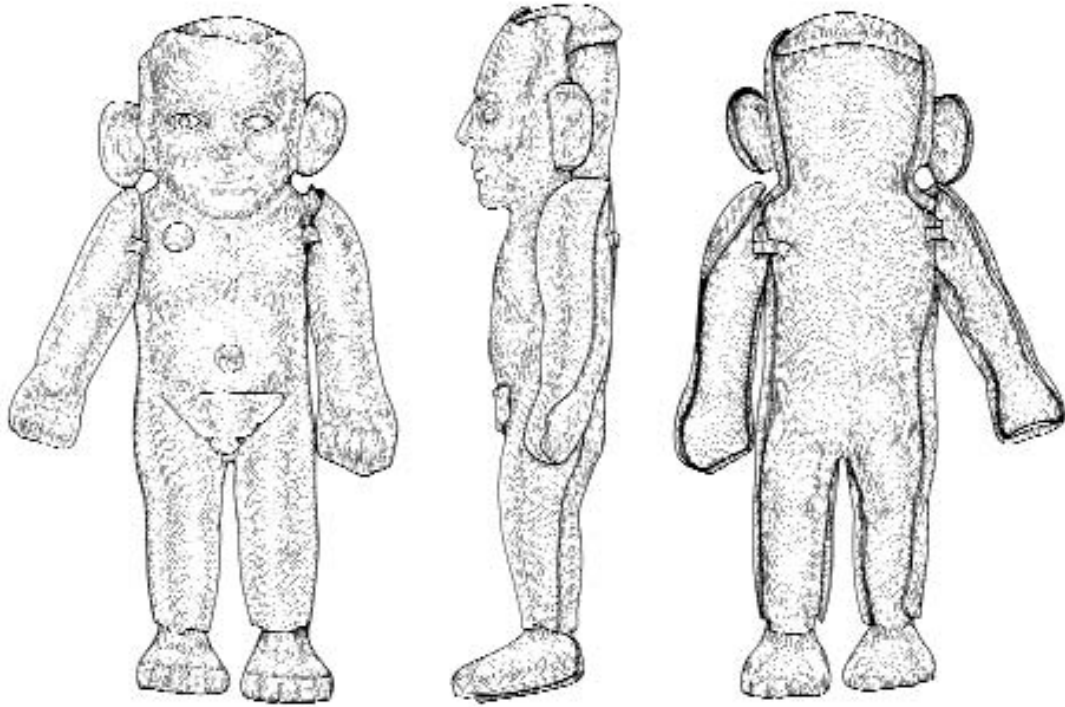

Figure 9.4 Copper figure 2, from Tomb 2 (height 19.5 cm).

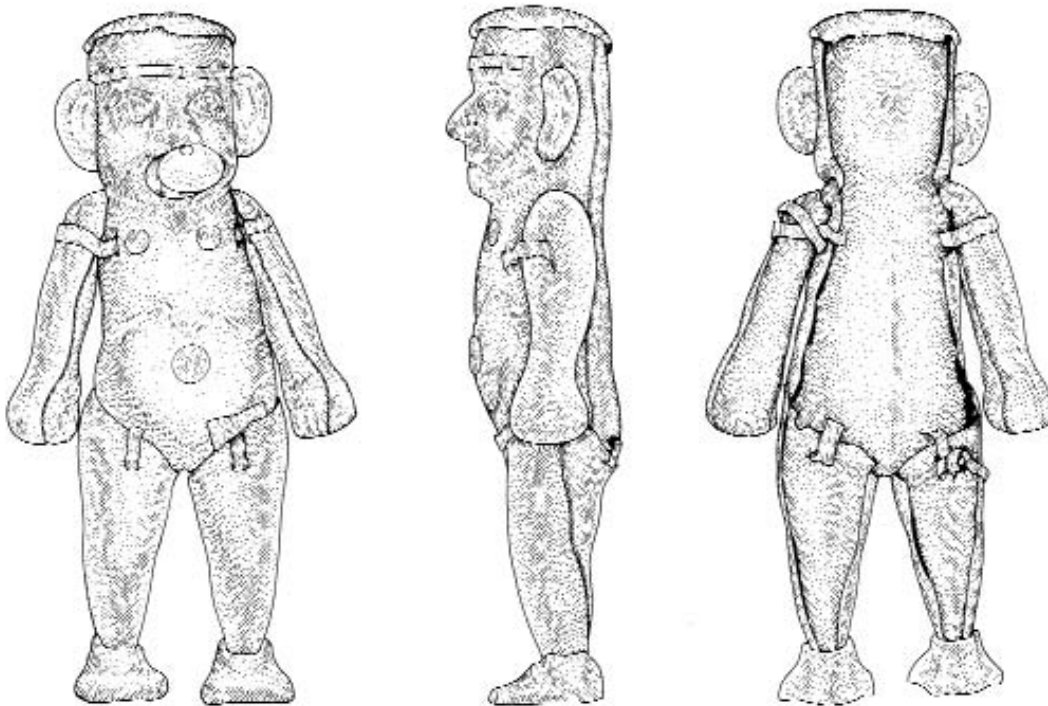

Figure 9.5 Copper figure 3, from Tomb 3 (height 18.5 cm).

ful study of their manufacture and details of their accoutrements reveals important differences between them. In the discussion that follows, they are referred to simply by their tomb designation: the one from Tomb A as A, the one from Tomb 1 as 1, etc.

Of the four copper figures, 3 is the most distinctive. Several features of its construction set it apart from A, 1, and 2 (Figs. 9.2–9.5). Most noticeable is that the head and torso were made as one part and the legs were made separately. The legs were then joined to the torso with copper straps. In contrast, the head, torso, and legs of A, 1, and 2 were made as one part. Copper figure 3 is also distinct from the others because the arms consist of an inner side and an outer side; on the other three figures the arms consist of a front side and a back side. In addition, the feet of 3 are attached by the lower part of the legs socketing downward into the feet, while the feet of the other three are attached by socketing up into the lower part of the legs. On 3, the copper sheet at the top of the head overlaps and curves downward around the entire circumference of the head; on the other three it fits behind the piece that forms the front and sides of the head, and only overlaps and curves downward at the back of the head. The overall posture of 3 also sets it apart from the other three; it is much fuller in the abdomen, hips, and upper thighs.

This might suggest that copper figure 3 is outside the tradition of the other three, but so many other features are shared by the copper figures that such a conclusion seems unwarranted. Figure 3 is similar to 1 in wearing a nose ornament and headband — the only copper figures that have either of these features. It is also similar to 1 in not having the toes delineated. On the other hand, 3 is similar to 2 in having a gilded navel covering, and it is similar to A in not having the genitals shown.

One could argue that A is, in fact, the most distinctive because it is the only one wearing a necklace and holding nose ornaments in its hands. It is also the only one that has the bottom of the feet attached with resin. Each copper figure has some features that are unique and some features that are shared with one or more of the others.

There is so much variation in the copper figures that they probably were not made by the same craftsman. Certainly there was no effort to make them appear the same. On the contrary, although there was a general concept of the appropriate size and form of a copper figure, there may have been a deliber-

ate attempt to avoid duplication and instead to make each one unique.

One final but enigmatic feature of the copper figures is that each contained something inside it. Figure A contained small pieces of broken Spondylus shell. Figure 1 contained small pieces of broken bone, and figure 2 contained small pieces of quartz and shell. These were loose inside the figure and would have caused a rattling sound if the figure was shaken. Thus, one might conclude that the contents were to make the copper figures serve as rattles, But figure 3 contained a small piece of a plain twill weave cotton textile that had been carefully folded. Since this textile could not have rattled, the contents of the copper figures must have been purely symbolic. That the contents of each were different from the others underscores the implication that each was meant to be unique.

WHY THE COPPER FIGURES?

The copper figures could have been made prior to the deaths of the individuals in these tombs, since it would have taken considerable time to manufacture them as well as to create the miniature objects associated with the copper figure in Compartment 2. Moreover, the close correspondence between those miniature objects and their full-sized counterparts in Tomb 2 suggests that there was prior knowledge of the objects to be buried in the tomb, and a deliberate effort to create miniatures of them for the adjacent compartment. This implies considerable preplanning. It is possible that the principal individuals in the tombs saw or had access to the copper figures during their lifetime. They even may have been instrumental in having the copper figures and miniature objects made.

The copper figure that was wrapped in textiles and placed on the roof of Tomb A is very intriguing. It is similar to the copper figures found in the compartments of Tombs 1, 2, and 3. Like those figures, it was wrapped in textiles and placed outside the burial chamber on its back with its head to the south. Each of the copper figures in Compartments 1, 2, and 3 was meant to represent the deceased in the adjacent full-sized tomb. Therefore, it seems likely that the copper figure above Tomb A was also a miniature representation of the person buried in the tomb below. These are the only Moche tombs

ever excavated that have a miniature of the deceased buried along with the full-sized tomb. What could have been the reason for this practice?

It is not possible to know why there were copper figures associated with Tombs A, 1, 2, and 3, but one explanation can be suggested. Each of the four tombs that contained a miniature copper figure had, as the principal individual in the funerary chamber, a person of unusually tall stature. These individuals would have stood out in their community in the same way that unusually tall people stand out in communities today. Perhaps there was a connection between the height of the men in the tombs and the presence of the copper figures that represented them in miniature.

In the past four decades of working with Moche art and archaeology, I have become convinced that two basic tenets of their worldview were duality and balance. One observes numerous examples of their deliberate combination of opposites: gold and silver, light and dark, male and female, young and old, sea and land, etc. The Moche appreciated the balance and complementarity of opposites, and they attempted to maintain balance between two extremes.

The occurrence of “giant” men in the local population may well have seemed out of balance, and in need of an opposite to renew the balance that was not there. When a “giant” died, the local people may have thought they could restore the balance by burying that individual in his tomb with a miniature version of him in the form of a small copper figure.

When Tomb A was created, this may have been achieved by simply wrapping the copper figure in elaborate textiles to form a funerary bundle and placing it on top of the roof with the figure extended, lying on its back with its head to the south, like the individual who was presumably wrapped in his funerary bundle on the floor of the tomb below. Later, when Tombs 1, 2, and 3 were created, the practice of burying the miniature copper figure was more elaborate. Instead of simply placing it above the roof of the tomb, a miniature funerary chamber was created. The copper figure, wrapped in its funerary bundle, was placed on the floor of the miniature burial chamber — on its back with its head to the south, just like the principal figure in the adjacent tomb. Additional offerings were placed inside the miniature burial chamber, reflecting in quantity and variety the objects that were placed in the adjacent tomb. The most elaborate manifestation of this practice was Tomb 2,

where the extraordinary quantity and variety of associated grave goods closely paralleled the inventory of miniature objects placed in the adjacent compartment.

Admittedly, suggesting balance as the motivation for creating a miniature burial on the occasion of the burial of a “giant” is speculative. It is also based on a very limited sample. As more archaeological excavation of Moche burials is conducted, it will be interesting to see if small copper figures continue to be found associated with burials of individuals of unusually tall stature, or in any other burial context.

Meanwhile, we are left with the intriguing set of tombs from Dos Cabezas. They provide a wealth of new information about the nature of Moche funerary practice, and they clearly demonstrate the extraordinary artistic and technological sophistication that characterized Moche ceramics and metalworking at the time they were created. They also provide some fascinating answers and many intriguing questions about the Moche people, who developed one of the most remarkable civilizations of the ancient world.

Appendix

VERTEBRATE FAUNAL REMAINS

Thomas A. Wake

Although many different kinds of animals are depicted in Moche iconography, the variety of those included in Moche tombs was limited to only a few species. This analysis assesses the animal remains included in the five excavated tombs at Dos Cabezas.

The few animal species recovered previously from Moche burials include llamas (*Lama glama*), dogs (*Canis familiaris*), cuy (*Cavia porcellus*), parrots (*Amazona* sp.), macaws (*Ara* cf. *militaris*, et al.), conch shells (*Strombus* sp.) and spiny oyster shells (*Spondylus princeps*) (Castillo 2003; Donnan 1995, 2003; Donnan and Mackey 1978; Donnan and McClelland 1997; Tello et al. 2003). Of these, llamas are the most common.

Llamas are usually represented in Moche tombs by heads and/or feet (Bawden 1996:155, 242, 322; Alva and Donnan 1993; Castillo 2003; Donnan 2003; Donnan and Mackey 1978; Donnan and McClelland 1997; Tello et al. 2003). Only rarely are complete individuals encountered, most often in the highest status tombs (e.g., Alva and Donnan 1992; Castillo 2003; Donnan 2003). The heads are typically removed from the body at the atlas or first vertebra and are usually isolated and not associated with any of the remaining vertebrae. The feet, representing both fore- and hind limbs, are typically disarticulated at the wrist or ankle. Cut marks are often found on the exterior surfaces of the wrist and ankle bones, indicating purposeful disarticulation. The meatier, high-utility parts such as the upper limbs, rib cage, and vertebrae are usually not included.

METHODS OF ANALYSIS

The Dos Cabezas animal offerings were analyzed one context (Tomb or Compartment) at a time. All specimens were cleaned with dry brushes and water where necessary to allow assessment of cut marks and/or pathologies. Most of the animal bone from the five tombs and three associated compartments was well-preserved. However, there were various indications that water entered the tombs, and the leeching effects of the water accelerated the degradation of the organic component (collagen) of the bones. This left the bone generally brittle and easily broken.

Specimens broken during recovery or curation, as indicated during laboratory analysis by clean, bright, broken surfaces free of any sediment, were reconstructed with water-soluble adhesive to facilitate measurement and provide accurate representation of the number of individual animals included as offerings. All specimens were photographed using a digital camera. Where necessary, photographs taken of the skeletal remains were compared to reference materials in various comparative collections in the United States, since the tomb offerings could not be readily transported out of Peru.

The specimens were measured using digital calipers with a computer interface and/or an osteometric board. All specimens were cataloged into a computer database.

The vertebrate faunal remains from the five Moche tombs at Dos Cabezas included camelids, macaws, and parrots (Table A1). The camelids were identified using comparative skeletal specimens, published diagnostic aids and statistical techniques (Pacheco et al. 1986; Von den Driesch 1976; Webb 1965). The incisors were of particular importance in identifying the camelid specimens to species. Wheeler (1982:12–13) states that llama and guanaco incisors are spatulate, have enamel covering all surfaces of the crown, and are clearly rooted. The vicuña has incisors that are rootless, nonspatulate and have enamel only on the labial surface (Wheeler 1982:12-13). Alpacas have nonspatulate incisors, enamel only on the labial surface, and become rooted with age (Wheeler 1982:13). Measurements of the proximal first phalange dimensions were also compared to averages for the four extant American camelid species. Based on the characteristics of the dentition and

Table A1 Faunal Remains in the Dos Cabezas Tombs

Common Name	Scientific Name	T1	C1	T2	C2	T3	C3	TA	TB
Llama	<i>Lama glama</i>	2h, 2fl, 1hl		1c, 1h	3h, 4fl, 4hl	1h	1h	2h	2h
Macaw	<i>Ara</i> sp.			1h					
Military Macaw	<i>Ara</i> cf. <i>militaris</i>			1c		1c		1c	
Amazon Parrot	<i>Amazona</i> sp., Lg.							1c	1c
Minimum number of animal offerings per tomb		5	0	4	11(3)	2	1	4	3

Notes: c = complete skeleton, f = fragment, h = head, v = vertebra, fl = distal forelimb, hl = distal hind limb.

the first phalange dimensions, all of the camelid specimens in the Dos Cabezas tombs are llama.

Sex was determined by the presence of large “fighting” canines present in adult males (Wheeler 1982:13–14) and/or enlarged suspensory ligament scars on the pubic bone that support the male sex organs (cf. Pacheco et al. 1986). Age was determined primarily by tooth eruption sequences and wear patterns (Wheeler 1982) and secondarily by degree and location of epiphyseal fusion. Wheeler’s (1982:17) corresponding age and tooth wear patterns were given ordinal wear stage designations (Table A2).

Table A2 Llama Remains in the Dos Cabezas Tombs

Location	Camelid	Presumed Sex	Age (yr/mo)
T1	Llama 1	M	11–13
T1	Llama 2	M	11–13
T2	Llama 1	?	4–4/6
T2	Llama 2	F	3
C2	Llama 1	F	3
C2	Llama 2	M	11–13
C2	Llama 3	M	12–14
T3	Llama 1	M	11–13
C3	Llama 1	M (gelding?)	14+
TA	Llama 1	M	4/6–4/9
TA	Llama 2	M (gelding?)	14+
TB	Llama 1	F	3
TB	Llama 2	?	14+

There were many cut marks on the llama remains (Table A3). These are consistently straight, deep, and V-shaped and have no accessory striations within them. All of these characteristics indicate that metal tools were used to dissect the llamas (Walker and Long 1977).

Table A3 Cut Llama Bones in the Dos Cabezas Tombs

Location	Specimen	Element	Side	Location of Cut Marks
T1	Llama 2	Astragalus	R	Proximal superior medial margin and mediomedial surface
T1	Llama 2	Calcaneus	R	Proximal superior surface and medial astragalar articular margin
T1	Llama 2	Cuneiform	L	Anterior superior and medial posterior surface
T1	Llama 2	Cuneiform	R	Anterior superior and medial posterior surface
T1	Llama 2	Lunar	R	Anterior superior and medial posterior surface
T1	Llama 2	Scaphoid	L	Lateral superior and posterior superior surfaces
T1	Llama 2	Scaphoid	R	Anterior, lateral, and posterior superior surface
T2	Llama 2	Cranium		Base of left occipital condyle
C2	Llama 2	Astragalus	R	Medial superior margin and surface, medial proximal margin, lateral superior margin
C2	Llama 2	Calcaneus	L	Lateral superior facet associated with fibulare
C2	Llama 2	Cuneiform	R	Anterio-lateral proximal and distal margins, lateral superior margin
C2	Llama 2	Metatarsal	L	Scrape marks on proximal medial shaft just below articular surface
C2	Llama 2	Metatarsal	R	Proximal medial shaft just below articular surface
C2	Llama 2	Pisiform	R	Posterior medial surface and anterior medial surface
C2	Llama 2	Scaphoid	R	Anterior superior margin (2 sets)
C2	Llama 2	Trapezoid	L	External medial and superior surfaces

TOMB 1

One complete llama skull, two disarticulated lower forelimbs, and one disarticulated lower hind limb were recovered from Tomb 1 (Fig. 7.7). The llama head includes the complete hyoid skeleton (Fig. A.1). The hyoid apparatus is essentially the skeleton of the tongue, providing support in the throat for tongue movement. In undisturbed skeletal form, the hyoid lies between the mandibles. The presence of the hyoid skeleton associated with this skull indicates that the head had been decapitated, complete with tongue and probably skin and fur.

All the teeth are fully erupted, fairly well worn, and covered with dental calculus (Figs. A.2, A.3). The incisors are consistent with the *L. glama* inci-



Figure A.1 Tomb 1 Llama 2, skull.



Figure A.2 Tomb 1 Llama 2, mandibular occlusal view with lamoid incisors and fighting canine.

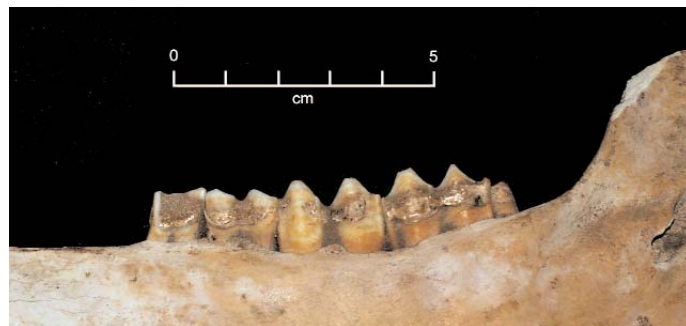

Figure A.3 Tomb 1 Llama 2, dental calculus.

sor enamel pattern. All four canines (one per side, upper and lower) are present and of large size. This strongly suggests the male sex. The level of occlusal attrition on the molars of the llama cranium corresponds to wear stages 36–40 or 11–13 years of age (Wheeler 1982:17).

Both of the camelid forelimbs, one left and one right, were disarticulated at the wrist. These forelimbs have the same general proportions, similar tendinal insertion scars, and appear to be of the same age. Both forelimbs were most likely derived from the same individual, perhaps the llama represented by the skull.

Cut marks are visible on several carpal bones from both forelimbs (Table A3, Fig. A.4). The left cuneiform and scaphoid both bear deep angled cut marks on their respective anterior and medial surfaces. The right cuneiform, lunar, and scaphoid also bear deep, angled cut marks on their respective anterior and medial surfaces. The characteristics of the cut marks indicate that metal tools were used to dissect the forelimbs (Walker and Long 1977).

The hind limb was disarticulated at the ankle and may belong to the same individual as the head and/or the forelimbs. The epiphyses of the limb bones are completely fused, indicating that growth had ceased. The carpals are well ossified and in some cases appear mildly arthritic, exhibiting zones of active bone redeposition at the margins of interelemental cartilage.

Cut marks are visible on the larger tarsal bones from the hind limb. The astragalus and calcaneus both bear deep, angled cut marks on their respective



Figure A.4 Tomb 1 Llama, cut marks on wrist.

superior, anterior, and medial surfaces, thus indicating metal tool use (Walker and Long 1977).

Based on the complete suffusion of all observed epiphyses and indications of mild arthritis, all three feet are most likely from a single older adult, possibly the individual represented by the skull. The size of the first phalanges of these three feet is slightly below average for llamas described in the available literature (Kent 1982; Miller and Burger 1995:431). Sex-based size dimorphism is noted in llamas, but unfortunately the differences in the distal skeletal elements have yet to be adequately determined. Therefore sex could not be assigned to the Llama 2 feet.

COMPARTMENT 1

No animal offerings were found in Compartment 1.

TOMB 2

The remains of two llamas, one complete individual (Llama 1) and one complete head (Llama 2), were recovered from Tomb 2. Llama 1 was found above the tomb chamber, separated by a layer of adobes and the original chamber roof beams (Figs. 5.2, 5.3). All of the major skeletal elements of the complete llama were fragmented. It should be noted that the length measurements for the major bones of this specimen were recorded from reconstructed elements. Unfortunately the cranium of the complete llama skeleton was pulverized and could not be reconstructed with the materials available.

All of the epiphyses are fully fused but still evident, indicating that growth had stopped and suggesting a young adult condition. The size of the first phalanges of the feet from the two fore- and hind limbs lie close to but below average for llamas as described in the available literature (Kent 1982; Miller and Burger 1995:431). Unfortunately the skull was highly fragmented, as were the sexually dimorphic canines. The incisors are consistent with the *L. glama* incisor enamel pattern. The third mandibular molars, which were complete, have wear patterns corresponding to wear stages 16–18, or

between 4 and 4½ years of age (Wheeler 1982:17).

The llama skull (Llama 2) found inside the burial chamber of Tomb 2 (Fig. 5.9) was fragmented, but the presence of the hyoid skeleton indicates that it was complete with tongue and probably skin and fur. The teeth in the cranium and mandibles are nearly fully erupted and only slightly worn. The teeth in the cranium and mandibles are nearly fully erupted and only slightly worn. The incisors are consistent with the *L. glama* incisor enamel pattern. All four canines (one per side, upper and lower) are present and of small size, strongly suggesting the female sex. The canines of this specimen represent adult dentition. No replacement teeth are evident in the canine alveoli. The level of occlusal attrition on the molars corresponds to wear stage 12 or three years of age (Wheeler 1982:17).

A single cut mark is visible on the inferior surface of the Llama 2 left occipital condyle (Fig. A.5). The cut mark runs transverse to the length of the skull along the long axis of the condyle, consistent with action that would remove the head from the body.

Skeletal remains of two birds were recovered from the chamber of Tomb 2. They are clearly macaws (*Ara* sp.). Both individuals are fully mature, based on the large size and complete ossification of the limb bones.

One specimen (Bird 1) was found near the head of the primary individ-

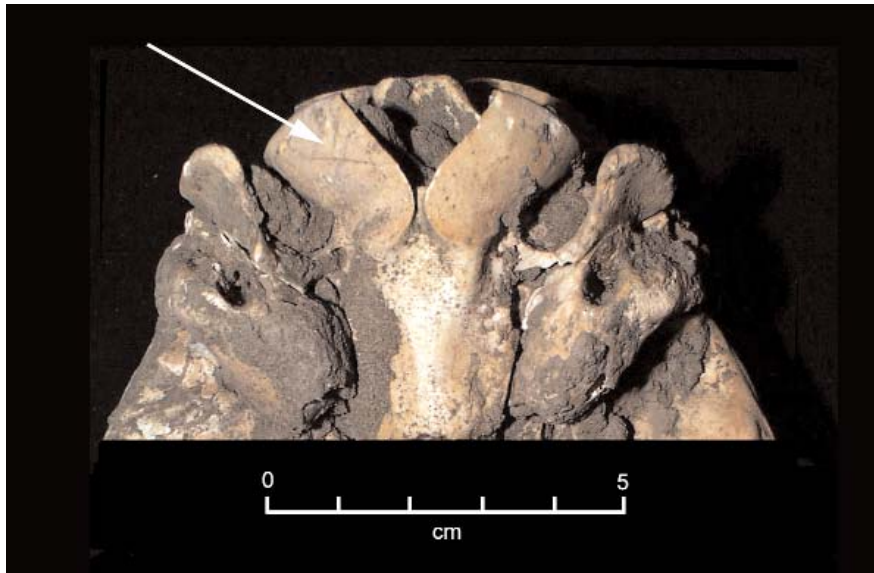

Figure A.5 Tomb 2 Llama 2, cut marks on the left occipital condyle.

ual (Figs. 5.9, 5.110). It is incomplete, and most of the recovered elements are fragmented. Only a few scraps of the cranial region were recovered, making identification possible only to the generic level (*Ara* sp. indet.). None of the characteristics suggestive of osteoarthritis (seen in other Dos Cabezas bird remains) are exhibited on this specimen.

The other specimen (Bird 2) was found lying near the feet of the tomb occupant at the other end of the chamber (Fig. 5.9). It is virtually complete and most closely approximates a military macaw (*Ara* cf. *militaris*) based on size comparisons with other macaw species and fine basicranial morphological distinctions. Bird 2 was excavated from a soil matrix that had infiltrated the feather-covered shin of the bird and then solidified. Impressions of the surface of the macaw's skin with many feather insertions were visible on several portions of the soil containing the Bird 2 bones.

Mild osteoarthritis is evident in the knee and shoulder joints of Bird 2. The joint most severely afflicted with osteoarthritis is the right mandibular articulation. The articular facet of the mandible is almost completely reworked with active bone, and where it is not burnished, the surface is roughened (Fig. A.6). The corresponding distal surface of the right quadrate is burnished and exhibits active bone redeposited around the edges of the articulation (Fig. A.7).



Figure A.6 Tomb 2 Bird 2, arthritic mandibular articulation.



Figure A.7 Tomb 2 Bird 2, arthritic quadrate.

COMPARTMENT 2

Three concentrations of llama bones were found in the upper level of Compartment 2 (Fig. 5.130). These are designated Llama 1, Llama 2, and Llama 3. Llama 1 consists of an isolated skull with *L. glama* incisor enamel pattern and tiny canine alveoli, indicating that it is most likely a female. The cheek teeth are not yet fully erupted and have little wear on the molars, corresponding to wear stage 12 or roughly three years of age (Wheeler 1982:17). The hyoid skeleton was found between the mandibles of this specimen.

The Llama 2 concentration included a skull as well as the left and right metacarpals and the left and right metatarsals. The skull has incisors with the *L. glama* incisor enamel pattern and large canines, indicating a male llama. The cheek teeth are fully erupted and quite worn, corresponding to wear stages 36–40 or 11–13 years of age (Wheeler 1982:17).

Two fore- and two hind limbs, one left and one right, respectively, were associated with Llama 2. The forelimbs were disarticulated at the wrist. Cut marks are visible on several carpal bones from both forelimbs (Fig. A.8). The left trapezoid bears deep, angled cut marks on the exterior and medial surfaces. The right cuneiform, pisiform, and scaphoid also bear deep, angled cut marks on their respective anterior and medial surfaces. All of the cut marks have characteristics of metal tool use (Walker and Long 1977).

The Llama 2 forelimbs have the same general proportions, similar tendinal insertion scars, appear to be the same age, and generally match each other. They most likely were derived from the same individual, probably the llama represented by the skull.

The hind limbs were disarticulated at the ankle and may belong to the same individual as the head and/or forelimbs. The epiphyses of the limb bones are completely fused, indicating growth had ceased. The carpals are well ossified and in some cases appear mildly arthritic, exhibiting zones of active bone redeposition at the margins of interelemental cartilage.

Cut marks are visible on the larger tarsal bones from the Llama 2 hind limbs (Fig. A.8). The right astragalus and metatarsal both bear deep, angled cut marks on their respective superior, anterior, proximal, and medial surfaces.



Figure A.8 Compartment 2 Llama 2, cut marks on the right astragalus and left calcaneus.

The left calcaneus and metatarsal also bear bold cut marks on their superior, anterior, and medial surfaces. These cut marks have characteristics of metal tool use (Walker and Long 1977).

The size of the first phalanges of the feet from the two pairs of fore- and hind limbs are slightly below average for llamas as described in the available literature (Kent 1982; Miller and Burger 1995:431). Sex-based size dimorphism is noted in llamas, but unfortunately, the differences in the distal skeletal elements have yet to be adequately determined. Therefore a sex could not be assigned to the Llama 2 feet.

The Llama 3 concentration in Compartment 2 included a skull as well as the left and right metacarpals and the left and right metatarsals with the associated phalanges, carpals, and tarsals. The Llama 3 skull has incisors with the *L. glama* incisor enamel pattern and large canines, indicating a male llama. Dental abscesses are present in both the mandible and maxilla (Figs. A.9, A.10). The cheek teeth are fully erupted and quite worn, corresponding to wear stages 38–42 or 12–14 years of age (Wheeler 1982:17).

Two forelimbs and two hind limbs, one left and one right, respectively, were associated with Llama 3. The forelimb feet were disarticulated in a fashion that left no visible cut marks. The carpals are well ossified and in some cases appear mildly arthritic, exhibiting zones of active bone redeposition at the margins of interelemental cartilage. The forelimbs have the same general



Figure A.9 Compartment 2 Llama 3, maxillary dental abscess.



Figure A.10 Compartment 2 Llama 3, mandibular dental abscess.

proportions, similar tendinal insertion scars, appear to be the same age, and generally match each other. Thus they were most likely derived from the same individual.

The Llama 3 hind limbs were disarticulated at the ankle, leaving no visible cut marks. They may belong to the same individual as the forelimbs of Llama 3. The epiphyses (growth plates) of the hind limb bones are completely fused, indicating growth had ceased.

The size of the first phalanges of the feet from the two pairs of fore- and hind limbs are slightly below average for llamas (Table A2) as described in the available literature (Kent 1982; Miller and Burger 1995:431). A sex could not be assigned to the Llama 3 feet. It is possible that the Llama 3 fore- and hind

limbs are from the same individual as the Llama 3 skull.

TOMB 3

A single llama skull was recovered from Tomb 3 (Fig. 6.7). It included the hyoid skeleton, which indicates that the head, complete with tongue, was included as an offering. The teeth are all fully erupted and well worn. The incisors are consistent with the *L. glama* enamel pattern. All four canines are present and of large size. Their size strongly suggests the male sex. The level of occlusal attrition on the molars corresponds to wear stages 36–40 or 11–13 years of age (Wheeler 1982:17).

In addition to the llama skull, the complete skeleton of one bird was recovered from Tomb 3 (Fig. 6.7). It is identified as a macaw, most likely the military macaw (*Ara cf. militaris*), based on size comparisons with other macaw species and fine basicranial morphological distinctions. This individual is fully mature and, based on the condition of some of the bones at the joints, of an advanced age.

Several of the epiphyses of the major limb bones exhibit varying degrees of bony lipping and redeposition characteristic of mild arthritis, a condition usually found in older adult vertebrates. The distal articular surfaces of both coracoids and humeri and the corresponding proximal articular surfaces of both ulnae (which form the elbow joint in a bird's wing) have bony lipping and redeposition around the margins of the now decomposed articular cartilage (Fig. A.11). Similar bony redeposition is evident around the margins of the proximal articular surfaces of both tibiotasri, or lower leg bones.



Figure A.11 Tomb 3 Bird 1, mild arthritis on the coracoid.

COMPARTMENT 3

The remains of a single llama skull were recovered from Compartment 3 (Figs. 6.29–6.31). These remains are well preserved and include the hyoid skeleton. The teeth are all fully erupted and fairly well worn. The incisors are consistent with the *L. glama* enamel pattern. All four canines are present and medium sized. The size of the canines suggests the male sex, but perhaps a neutered male. The level of occlusal attrition on the molars corresponds to a wear stage greater than 42 or probably in excess of 14 years of age (Wheeler 1982:17).

TOMB A

Two llama skulls (Llama 1 and Llama 2) were recovered from Tomb A (Fig. 2.3). They are well preserved and complete, and both have the hyoid skeleton. The teeth in Llama 1 are all fully erupted but only somewhat worn. The incisors are consistent with the *L. glama* enamel pattern. All four canines are present and of large size, strongly indicative of a male. The level of occlusal attrition on the molars of the Llama 1 cranium corresponds to wear stages 18–19 or 4½ to 4¾ years of age (Wheeler 1982:17).

The teeth in Llama 2 are all fully erupted and well worn, and exhibit mandibular periostitis (Fig. A.12). The incisors are consistent with the *L. glama* enamel pattern. All four canines are present and of medium size. The size of the Llama 2 canines suggests the male sex, but perhaps a neutered male. The



Figure A.12 Tomb A Llama 2, mandibular periostitis.

level of occlusal attrition on the molars of the Llama 2 cranium corresponds to a wear stage greater than 42 or probably in excess of 14 years of age (Wheeler 1982:17).

Skeletal remains of two different birds were recovered from the north end of Tomb A: one macaw and one parrot (Fig. 2.3). Both specimens are fragmented and relatively incomplete. The macaw specimen most closely resembles a military macaw (*Ara cf. militaris*), based on size comparisons with other macaw species and fine morphological distinctions. The parrot most closely resembles the larger species of Amazon parrots (*Amazona* sp.), possibly the mealy Amazon (*A. farinosa*) or the yellow-lored Amazon (*A. ochrocephala*). Both individuals are fully mature and, based on the condition of some of the bones at the joints, of advanced age. Elements of each of the specimens exhibit varying degrees of bony lipping and redeposition characteristic of mild arthritis, a condition usually found in older adult vertebrates.

The left mandibular articulation of the macaw exhibits evidence of mild osteoarthritis (bony lipping and redeposition around the margins of the articular cartilages). The remaining bones are all cranial elements plus the first two vertebrae. Other than the atlas and axis, no postcranial elements were recovered, leading to the possibility that only the head was included in Tomb A as an offering.

The Tomb A parrot, while not a skeletally complete specimen, includes both cranial and postcranial bones, indicating the inclusion of the whole animal in the tomb chamber. Skeletal pathology in the parrot is limited to osteoarthritis. The distal left coracoid (Fig. A.13) exhibits obvious bony redeposition on the scapular and humeral articular facets, as well as in the zones surrounding the distal end.



Figure A.13 Tomb A Parrot, severe arthritis on the coracoid.

TOMB B

Two llama skulls (Llama 1 and Llama 2) were recovered from Tomb B (Fig. 3.7). Both are with their respective hyoid skeletons. Llama 1 consists of an isolated head with the *L. glama* incisor enamel pattern and tiny canine alveoli, suggesting that it is a female. The cheek teeth are not yet fully erupted and have little wear on the molars, corresponding to wear stage 12 or roughly three years of age (Wheeler 1982:17).

Llama 2 is poorly preserved and heavily fragmented. The cranial and mandibular teeth are all well worn. The incisors were not recovered, so the presence of the *L. glama* incisor enamel pattern could not be confirmed. The canines are present but highly fragmented, and the mandibular and maxillary regions bearing their alveoli could not be reconstructed. Thus sex could not be determined. The level of occlusal attrition on the molars of Llama 2 corresponds to a wear stage greater than 42 or probably in excess of 14 years of age (Wheeler 1982:17).

Skeletal remains of a parrot were recovered from the burial chamber of Tomb B (Fig. 3.7). It is represented by a nearly complete skeleton and is virtually indistinguishable from the parrot in Tomb A. As with the parrot in Tomb A, its large size suggests that it may represent one of the larger *Amazona* species such as the mealy or yellow-lored Amazon.

The parrot exhibits two types of skeletal pathology: arthritis and healed traumatic injury. Bony lipping and redeposition associated with osteoarthritis are seen in most of the main wing joints as well as in the knees. Eburnative osteoarthritis is evident in two areas: the right shoulder joint where the scapula, coracoid, and humerus intersect and the articular surface of the right mandible and coracoid (both distal and proximal). Both of these areas are associated with healed fractures, suggesting the osteoarthritis developed as a result of post-fracture-related displacement or realignment of the joints in question.

Two skeletal elements, the right mandible and the right scapula, exhibit characteristics associated with healed fractures. The right side of the mandible (Fig. A.14) exhibits evidence of a single break, mild displacement, and subsequent rehealing. The fracture crosses the midsection of the horizontal ramus just posterior to the thickened anterior region that supports the



Figure A.14 Tomb B Parrot, healed mandibular fracture.

lower bill covering. The fracture occurred at the thinnest part of the horizontal ramus, probably the area of the most susceptible to traumatic injury. The fracture resulted in a noticeable lingual displacement of the horizontal ramus. The displacement of the horizontal ramus almost certainly resulted in misalignment of the mandibular/quadratic joint and caused the eburnative arthritis visible on the articular surface of the right mandible as well as on the distal surface of the right quadrate. The added stress on the quadrate also resulted in an arthritic condition on the proximal surface where it articulates with the temporal bone. The fractures are well healed and occurred well before the death of the parrot.

The parrot's right scapula (Fig. A.15) exhibits evidence of a fracture at the proximal end of the scapular shaft, just distal to the area surrounded by ligaments associated with the shoulder joint. The fracture was displaced and healed out of correct alignment. The healing is complete, but the margins of the healed area are somewhat roughened. The misaligned healing of the fracture almost certainly contributed to the eburnative osteoarthritis of the right shoulder joint. It is possible that the parrot could have flown subsequent to healing, but development of osteoarthritis in the shoulder joint could have limited its flight capabilities.



Figure A.15 Tomb B Parrot, healed scapular fracture.

TREATMENT OF THE ANIMAL CONTENTS

Cut marks are visible on several of the llama head, wrist, and ankle bones. Most of the isolated fore- and hind limb units bear cut marks on one or more of the respective tarsal or carpal bones (Table A1). Most of the tarsal and carpal bones that have cut marks bear multiple individual cuts, indicating repeated individual cutting motions. One llama skull (Fig. A.5) bears a single bold transverse cut mark on its left occipital condyle. All of the identified cut marks exhibit characteristics consistent with the use of relatively broad-edged sharp metal cutting implements. The one complete llama skeleton that was found in the tombs at Dos Cabezas, the one above the roof of Tomb 2, bears no cut marks.

Llama heads (including the tongue), forelimbs, and hind limbs are the primary offerings placed in the tombs and their compartments. No isolated higher utility skeletal elements or parts such as ribs, lumbar vertebrae, or upper limb bones were recovered. Therefore, meat was probably not the primary purpose of the llama offerings (see Aldenderfer 1998:105).

LLAMA PATHOLOGIES

Pathologies visible on the Dos Cabezas llama heads are limited to tooth wear and various dental pathologies. No signs of malnutrition or anemias such as

cribria orbitalia and ectocranial thickening or dental hypoplasias were evident. All the llama heads had teeth bearing varying degrees of dental calculus (Fig. A.3). The dental calculus probably contains opal phytoliths and starch grains of the plant foods that the llamas were fed. Detailed analysis of selected calculus samples could shed light on Moche herd management practices, at least in terms of whether the llamas present in the tombs were fed a generalized fodder or received food supplements in the form of grain (maize) or exotic plant materials.

Abscesses are evident in several of the individual llamas (Figs. A.9, A.10). Most of these appear to be due to encapsulated infections associated with molariform tooth roots, often with some degree of active bony regrowth on the wound margins. One abscess (Fig. A.12) appears to have been particularly pervasive. The original tooth-associated abscess appears to have spread into the marrow cavity of the jaw as well as in the periosteal space. A layer of active porous bony regrowth on the horizontal ramus indicates infection-related periostitis.

BIRD PATHOLOGIES

Pathologies observed on the bird remains are limited to arthritis and healed bone fractures. All the individual parrots found in Tombs A and B bear indications of some level of arthritis on at least some of their respective skeletal elements. Arthritic lipping to varying degrees was observed usually on elements of the shoulder girdle (Figs. A.11, A.13), some leg bones, and in the mandibular articulation (Figs. A.6, A.7).

Eburnative arthritic lesions were observed only on the Tomb B parrot mandibular articulation (Fig. A.6), most likely associated with the healed, slightly displaced, traumatic fracture it received. This parrot also shows signs of a healed fracture on the midshaft of the right scapula (Fig. A.15). With a broken scapula, flight would likely be compromised or at least painful and difficult. A broken mandible is even more life-threatening.

Parrots use their bills to feed, preen, and interact socially. Both the upper and lower portions of the bill are mobile in both parrots and macaws, which adds to the general dexterity of the group. A working jaw is absolutely imper-

ative to a parrot's well-being. A parrot simply could not eat or take care of itself without one. Parrots typically use the mandible to hold a food item while the sharp upper jaw excises a chunk of fruit or nut covering. A parrot with a broken jaw would not be able hold on to food items or consume them — at least not without a considerable amount of pain. The fact that the parrot in Tomb B recovered from two fractures is testament to a certain level of care and nurturing provided to that bird. There was certainly a period of time when the parrot received nutrients from a source that could prepare suitable food for a parrot with a broken jaw, such as mashed fruit or ground seeds; almost certainly a human captor/caregiver. Close association of humans and parrots is clearly portrayed in Moche art (Fig. A.16), and it is likely that this resulted in affectionate bonding.



Figure A.16 Moche fineline painting of humans interacting with parrots.

REFERENCES CITED

- Aldenderfer, Mark S.
1998 *Montane Foragers: Asana and the South-Central Andean Archaic*. University of Iowa Press, Iowa City.
- Alva, Walter
1994 *Sipán*. Colección Culturay Artes del Perú. Cervecería Bakus & Johnston S.A., Lima.
- Alva, Walter and Christopher B. Donnan
1993 *Royal Tombs of Sipán*. Fowler Museum of Cultural History, University of California, Los Angeles.
- Bawden, Garth
1996 *The Moche*. Blackwell Publishers, Cambridge, Massachusetts.
- Borrero, Lewis
1990 Fuego-Patagonian Bone Assemblages and the Problem of Communal Guanaco Hunting. In *Hunters of the Recent Past*, edited by Leslie B. Davis and Bryan O. K. Reeves. Unwin Hyman, London.
- Castillo, Luis Jaime
2003 Los Últimos Mochicas en Jequetepeque. In *Moche: Hacia el Final Del Milenio, Actas del Segundo Coloquio Sobre la Cultura Moche*, edited by Santiago Uceda and Elías Mujica. Universidad Nacional de La Libertad, Trujillo.
- Castillo, Luis Jaime and Christopher B. Donnan
1994 Los Mochicas del Norte y los Mochicas del Sur. In *Vicus*. Colección Arte y Tesoros del Perú. Banco de Crédito del Perú, Lima.
- Cordy-Collins, Alana
2003 Five Cases of Prehistoric Peruvian Gigantism: Mummies in a New Millenium. *Proceedings of the 4th World Congress on Mummy Studies*, edited by Neils Lynnerup, Claus Andreasen and Joel Berglund. Greenland National Museum and Archives.
- Donnan, Christopher B.
1976 *Moche Art and Iconography*. UCLA Latin American Center Publications. University of California, Los Angeles.
1978 *Moche Art of Peru*. Museum of Cultural History, University of California, Los Angeles.
1992 *Ceramics of Ancient Peru*. Fowler Museum of Cultural History, University of California, Los Angeles.
1995 Moche Funerary Practice. In *Tombs for the Living: Andean Mortuary Practices*, edited by Thomas D. Dillehay. Dumbarton Oaks, Washington, D.C.

- 2001 Moche Burials Uncovered. *National Geographic* 199: 58–73.
- 2003 Tumbas con Entierros en Miniatura: Un Nuevo Tipo Funerario Moche. In *Moche: Hacia el Final Del Milenio, Actas del Segundo Coloquio Sobre la Cultura Moche*, edited by Santiago Uceda and Elías Mujica. Universidad Nacional de La Libertad, Trujillo.
- 2004 *Moche Portraits from Ancient Peru*. University of Texas Press, Austin.
- 2006a Numerical Patterns in Moche Tombs. In *Backdirt*. Cotsen Institute of Archaeology at UCLA University of California, Los Angeles.
- 2006b A Moche Cemetery at Masanca, Jequetepeque Valley, Peru. *Nawpa Pacha*. Institute of Andean Studies, Berkeley.
- ms.a The Moche Use of Numbers and Number Sets. In *Foundations of Andean Civilization: Papers in Honor of Michael Moseley*, edited by Patrick Williams and Joyce Marcus. Cotsen Institute of Archaeology at UCLA, University of California, Los Angeles.
- ms.b The Galinazo Illusion. In *The Gallinazo Culture of Northern Peru*, edited by Jean-Françoise Millaire. McGill University Press, Toronto.
- Donnan, Christopher B. and Daisy Barreto C.
- 1997 A Moche Cane Coffin from Pacatnamu. In *The Pacatnamu Papers, Volume 2: The Moche Occupation*, edited by Christopher B. Donnan and Guillermo A. Cock. Fowler Museum of Cultural History, University of California, Los Angeles.
- Donnan, Christopher B. and Carol J. Mackey
- 1978 *Ancient Burial Patterns of the Moche Valley, Peru*. University of Texas Press, Austin.
- Donnan, Christopher B. and Donna McClelland
- 1997 Moche Burials at Pacatnamu. In *The Pacatnamu Papers, Volume 2: The Moche Occupation*, edited by Christopher B. Donnan and Guillermo A. Cock. Fowler Museum of Cultural History, University of California, Los Angeles.
- 1999 *Moche Finesline Painting: Its Evolution and Its Artists*. Fowler Museum of Cultural History, University of California, Los Angeles.
- Kent, Jonathan D.
- 1982 *The Domestication and Utilization of the South American Camelids: Methods of Analysis and Their Application to Circum-Lacustrine Sites in Bolivia and Peru*. Ph.D. dissertation, Department of Anthropology, Washington University, St. Louis.
- Koepke, Maria
- 1970 *The Birds of the Department of Lima, Peru*. translated by Erma J. Fisk. Livingston Publishing Co., Wynnewood, Pennsylvania.
- Larco Hoyla, Rafael
- 1948 Cronología arqueológica del norte del Perú. Biblioteca del Museo de Arqueología Rafael Larco Herrera, Hacienda Chiclín. Sociedad Geográfica Americana, Buenos Aires
- McClelland, Donna
- ms. Ulluchu: An Illusive Fruit. In *The Art, the Arts, and the Archaeology of the Moche: An Ancient Andean Society of the Peruvian North Coast*, edited by Steve Bourget. University of Texas Press, Austin.

- Mengoni-Gonalons, Guillermo L.
 1991 La Llama y sus Productos Primarios. *Arqueología: Revista de la Sección Prehistoria* 1.
- Miller, George R. and Richard L. Burger
 1995 Our Father the Caiman, Our Dinner the Llama: Animal Utilization at Chavin de Huantar, Peru. *American Antiquity* 60(3).
- Montoya Vera, María
 1999 Plovos de Espingo. *Revista Arqueológica Sian* 8. Trujillo.
- Moseley, Michael E., Christopher B. Donnan and David K. Keefer
 ms. Convergent Catastrophe and the Demise of Dos Cabezas. In *The Art, the Arts, and the Archaeology of the Moche: An Ancient Andean Society of the Peruvian North Coast*, edited by Steve Bourget. University of Texas Press, Austin.
- Narvaez, Alfredo
 1994 La Mina: Una Tumba Moche I en el Valle de Jequetepeque. In *Moche: Propuestas y Perspectivas*. Actas del Primer Coloquio Sobre la Cultura Moche, edited by Santiago Uceda and Elías Mujica. Universidad Nacional de La Libertad, Trujillo.
- Nelson, Andrew
 1998 Wandering Bones: Archaeology, Forensic Science and Moche Burial Practices. *International Journal of Osteoarchaeology* 8:192–212.
- Pacheco, Victor R., Alfredo Altamirano and Erma Guerra
 1986 Osteology of the South American Camelids, translated by Elsie Sandefur. *Archaeological Research Tools, Vol. 3*. Institute of Archaeology, University of California, Los Angeles.
- Pozorski, Shelia and Thomas Pozorski
 2003 La Arquitectura Residencial y la Subsistencia de los Habitantes del Sitio de Moche: Evidencia Recuperada por el Proyecto Chan Chan—Valle de Moche. In *Moche: Hacia el Final Del Milenio, Actas del Segundo Coloquio Sobre la Cultura Moche*, edited by Santiago Uceda and Elías Mujica. Universidad Nacional de La Libertad, Trujillo.
- Sokal, Robert R. and F. James Rohlf
 1981 *Biometry*. W.H. Freeman and Co., New York.
- Strong, William D. and Clifford Evans, Jr.
 1952 Cultural Stratigraphy in the Virú Valley, Northern Peru: The Formative and Florescent Epoch. *Columbia Studies in Archaeology and Ethnology*, 4. Columbia University Press, New York.
- Tello, Ricardo, José Armas and Claude Chapdelaine
 2003 Prácticas Funerarias Moche en el Complejo Arqueológico Huacas del Sol y de la Luna. In *Moche: Hacia el Final Del Milenio, Actas del Segundo Coloquio Sobre la Cultura Moche*, edited by Santiago Uceda and Elías Mujica. Universidad Nacional de La Libertad, Trujillo.
- Verano, John W.
 1997 Physical Characteristics and Skeletal Biology of the Moche Population at Pacatnamu. In *The Pacatnamu Papers, Volume 2: The Moche Occupation*, edited by Christopher B. Donnan and Guillermo A. Cock. Fowler Museum of Cultural History, University of

California, Los Angeles.

Von Den Driesch, Angela

1976 A Guide to the Measurement of Animal Bones from Archaeological Sites. *Peabody Museum Bulletin 1*. Peabody Museum of Archaeology and Ethnology, Harvard University.

Walker, Philip L. and John C. Long

1977 An Experimental Study of the Morphological Characteristics of Tool Marks. *American Antiquity* 42(4).

Webb, S. David

1965 The Osteology of Camelops. *Bulletin of the Los Angeles County Museum of Science, No. 1*.

Wheeler, Jane C.

1982 Aging Llamas and Alpacas by Their Teeth. *Llama World* 1(2):

1995 Evolution and Present Situation of the South American Camelidae. *Biological Journal of the Linnean Society* 54.

INDEX

- animal bone, 58, 102, 208
- animal pelt, 136

- basketry, 78, 81, 83, 84
- bat, 81, 82, 107, 123, 124
- beads. *See* Moche bead work
- bench. *See* Huaca dos Cabezas pyramid
- bin. *See* Huaca dos Cabezas pyramid
- bird. *See* macaw, Moche metal work, parrot
- bowl
 - copper, 77, 95, 141
 - gourd, 130, 147, 155, 168
- burial chambers. *See* Huaca dos Cabezas pyramid Tombs A, B, 1, 2, and 3
 - looted. *See* Huaca dos Cabezas looting
 - re-entry, 27, 28,

- cane, 173, 174
 - coffin, 146, 190
 - frame, 145
 - roofing, 25, 43, 70
 - shaft, 110, 155
- cat tail, 25
- chisel. *See* Moche metal work
- chronology, 197–198
- conch shell, 211
- condor, 126, 127, 132, 133, 159
- copper. *See* Moche metal work
- copper figures. *See* miniature copper figures
- coral, 173, 179
- cotton. *See* Moche textiles
- Crested Animal, 82, 98, 120, 121, 123, 124, 128, 134, 135, 147, 159, 161, 176, 177
- curated burial, 30, 196
- cuy, 211

- Decapitator, 84, 94
- dog, 211
- Dos Cabezas site, 2–7, 202
 - ancient population, 6
 - Chimu occupation, 7
 - Chimu-Inca occupation, 7
 - colonial occupation, 7
 - domestic architecture, 9
 - Huaca dos Cabezas. *See* Huaca dos Cabezas pyramid
 - Lambayeque occupation, 7
 - location, 5
 - Moche occupation, 6, 7, 8, 9

pre-ceramic occupation, 6
 present occupation, 6
 size, 5
 drum, drum-shaped figure, 118, 145

engaging spur. See Moche metal work
 erosion. See Huaca dos Cabezas pyramid
 espingo, 118, 119

feathered textiles. See Moche textiles
 feline, 38, 131, 132, 136, 138, 146
 funerary bundles, 72, 73, 74, 75, 76, 81, 86, 87, 89, 90, 93, 95, 103, 112, 118, 119, 129, 133, 138, 145, 151, 152, 153, 156, 157, 158, 161, 174, 179, 194, 196, 200
 clay encased, 72, 73, 74, 75

Gallinazo style, 9, 147
 gilded copper. See Moche metal work

head cloth. See Moche textiles
 headdress. See Moche headdress
 helmet, 108

Huaca dos Cabezas pyramid, 5, 6, 7, 10, 11, 12, 13
 adobe wall, 10, 11, 42, 47, 166, 167
 architectural modification—southwest corner, 41, 195
 Stage 1, 42
 Stage 2, 43–44
 Stage 3, 44–47
 Stage 4, 48–50
 Stage 5, 51–52
 Stage 6, 53–54
 Stage 7, 56–58
 Stage 8, 59–60
 Stage 9, 61–62
 Stage 10, 165–166
 Stage 11, 167, 170
 Stage 12 early, 186
 Stage 12 late, 187–188
 Stage 13, 189
 bench, 63, 188, 189
 bin, plastered and painted, 44, 45, 46, 47, 48, 49, 50, 51, 53, 54, 55, 56, 65, 191
 erosion, 13, 41, 50, 59, 60, 61, 65, 151, 166, 169, 187
 floor
 clay 65
 sand-covered, 27, 36, 38, 39, 72, 131
 looting, 11, 13, 15, 16, 17, 19, 30, 38, 41, 43, 45, 46, 191
 painted wall, 44
 patio, 11
 platform, 10, 45, 188, 189
 plastered wall, 44
 retaining wall, 12, 17, 46, 48, 49, 51, 56, 60, 61, 62

sandy fill, 13, 15, 16, 19, 29, 43, 45, 48, 166, 167, 189, 191
 southwest corner, 12, 13, 14, 191, 195
 Tomb A, 16, 19, 20, 21, 52, 57, 63, 190, 191, 197, 198, 201, 202, 203, 208,
 209, 224, 225, 229
 construction, 20, 21, 25, 57
 location, 16, 19
 measurements, 25
 occupants, 25, 27, 181
 re-entry, 25, 26, 27, 38, 39, 44, 191
 Tomb B, 16, 29, 52, 63, 191, 197, 198, 226, 227, 229, 230
 construction, 33, 34, 36, 37, 57
 location, 16, 29
 measurements, 36
 occupants, 29, 30, 32, 33
 re-entry, 38, 39, 44, 191
 Tomb 1, 61, 63, 65, 66, 167, 169, 192, 193, 194, 198, 199, 201, 209,
 214–216
 compartment, 65, 66, 167, 170, 183, 190, 194, 195, 208, 217
 construction, 169, 195, 196
 location, 167, 169, 170, 186, 187, 199
 measurements, 169, 194
 occupants, 169, 172, 173, 176, 177
 Tomb 2, 61, 62, 63, 65, 66, 73, 74, 147, 166, 167, 169, 192, 193, 194, 196,
 197, 198, 200, 201, 217, 218, 219
 compartment, 61, 62, 65, 66, 130, 131, 132, 138, 139, 166, 167, 170,
 177, 190, 193, 194, 195, 201, 208, 209, 220, 221
 construction, 65, 195, 196
 location, 60, 61, 62, 65, 66, 170, 186, 187
 measurements, 65, 129, 194
 occupants, 65, 66, 102, 109, 110, 129, 181
 sub-floor burial, 129
 Tomb 3, 61, 62, 63, 65, 66, 149, 165, 166, 167, 169, 170, 192, 193, 194,
 195, 198, 209, 223
 compartment, 61, 62, 65, 66, 163, 165, 166, 167, 201, 208, 224
 construction, 149, 150, 195, 196
 location, 149, 150, 165, 170, 186, 187
 measurements, 151, 194
 occupants, 149, 150, 151, 152, 153, 155, 160, 162, 181

 jar. See Moche ceramics
 Jequetepeque River, 2, 4, 5
 Jequetepeque Valley, 2, 4, 5, 6, 7
 junco grass, 78, 82, 146, 190

 La Mina, 99
 lapis lazuli, 3
 leather, 104, 183
 lizard, 106, 107, 109, 110, 154, 155
 llama, 14, 19, 21, 25, 33, 34, 65, 66, 120, 130, 131, 153, 163, 164, 169, 171,
 179, 195, 201, 211–229
 Loma Negra, 202, 203, 204
 looting. See Huaca dos Cabezas looting

macaw, 21, 211, 218, 219, 223
 marsh grass, 25
 mask. See Moche metal work
 matting, 75, 173, 174, 190
 miniature copper figures, 194, 203–210
 Tomb A, 21, 23, 204, 207
 Compartment 1, 182, 183, 184, 185, 192, 196, 205, 207
 Compartment 2, 113, 138, 139, 140, 141, 142, 143, 144, 145, 165, 196,
 206, 207
 Compartment 3, 164, 165, 192, 196, 206, 207
 Moche
 area, 1, 2, 3
 artistic excellence, 1
 craft specialists, 1
 diet, 3
 domestic architecture, 9
 systems of distribution, 3, 4
 technology, 4, 199, 210
 trade, 3, 4
 Moche bead work. See beads
 beaded pectoral, 102, 160, 161
 copper, 65
 on seated figure 120
 quartz, 102, 200, 208
 shell, 37, 160, 208
 Moche ceramics, 8, 9, 14, 193, 194, 196, 198, 199
 blackware, 38, 124, 126, 127, 131, 132, 133, 154, 184
 dipper, 125, 126, 153, 154, 155, 178, 179, 180, 181, 200
 double-chambered whistling bottle, 125, 131, 183, 184, 185, 190, 196, 200
 jar, 8, 22, 23, 30, 31, 122, 123, 169, 171, 190, 201, 203
 ofrenda, 19, 24, 30, 36, 37, 120, 125, 130, 131, 155, 163, 185, 200, 201,
 202
 olla, 122, 123, 124, 201
 reclining figure, 126, 127,
 redware, 22, 99, 122, 123, 126, 154, 161, 171, 178, 179, 180, 181
 seated figure, 121
 stirrup spout bottle, 8, 118, 120, 121, 122, 123, 124, 125, 126, 127, 128,
 131, 132, 133, 138, 154, 161, 171, 179, 180, 184, 200, 201
 Moche feather work, 83, 89
 Moche headdresses, 193, 194
 band, 84, 85, 88, 93, 134, 135, 141, 145
 basket cylinder framework, 78, 81, 83, 84, 121, 133, 134, 136, 137, 141,
 145, 159, 160, 176
 grass ring framework, 82, 136, 138, 146
 platelets. See Moche metal work
 Moche metal work
 axe, 77, 145
 beads, 65
 bowl, 77, 95
 chisel, 112, 113, 114, 145, 147, 190, 196
 copper, 14, 37, 77, 95, 110, 112, 114, 115, 116, 130, 139, 143, 146, 164,
 165, 174, 185, 194, 196, 204, 205, 206, 207, 208, 209
 copper figures. See miniature copper figures

crescent shaped ornament, 91, 95, 106, 177
 disc, 82, 90, 96, 99
 ear ornament, 99, 109
 engaging spur, 109, 110, 114, 115, 155, 174, 196
 foil, 100, 101, 200
 gilded copper, 14, 77, 78, 82, 84, 85, 86, 89, 90, 91, 92, 93, 95, 96, 97, 104,
 108, 109, 117, 119, 133, 138, 139, 141, 145, 146, 155, 158, 162,
 176, 177, 196, 200
 gold, 98, 99, 100, 101, 104, 161, 162, 176, 196, 200
 headdress ornament, 85, 86, 91, 108, 109, 133, 200, 201
 ingot, 201
 mask, 96, 97, 98, 102, 141
 nail, 115, 116
 nose ornament, 97, 98, 99, 100, 101, 106, 107, 130, 141, 147, 160, 161,
 162, 174, 176, 194, 200, 201
 pairing of gold and silver, 98, 99, 106, 107, 146, 209
 platelets, 78, 79, 80, 81, 82, 83, 86, 88, 89, 92, 96, 97, 108, 109, 119, 134,
 136, 137, 139, 141, 145, 157, 158, 159, 160, 176, 177, 196
 rivet, 77, 115, 116
 scepter, 111, 117, 118, 139
 silver, 98, 99, 107, 161, 162, 175, 196
 spear point, 110, 114, 116, 142, 155
 tweezers, 175
 tumi, 111, 114
 sheet metal objects, 113, 175
 bird, 92, 134
 feet, 104, 105, 119, 142
 hands, 103, 104, 105, 119, 142
 heads, 104, 105, 109, 113, 136, 137, 159
 legs, 113
 Moche textiles, 3, 81, 104, 113, 169, 171, 173, 176, 190
 banner, 95, 119, 201
 burned, 30
 cord / string, 110, 114, 155
 cotton, 75, 78, 118, 133, 208
 decomposed, 14, 27, 37, 39, 72, 75, 78, 118, 119, 138, 151, 157, 165, 174,
 185
 feathered, 83, 89
 head cloth, 96, 141
 herringbone weave, 75
 platelet-covered
 banner, 95
 shirt, 89, 108, 141, 145
 twill weave, 75, 208
 wool, 118, 174
 monkey, 98, 99
 Moon Animal. See Crested Animal

 number sets, 68, 69, 130, 163, 169, 185, 199–202

 octopus, 120
 offering
 broken ceramics, 8, 9, 30, 31

organic liquid, 185
 ofrenda. See Moche ceramics
 owl, 120, 124, 143

 parrot, 21, 224, 33, 34, 35, 120, 128, 131, 132, 153, 155, 201, 225, 226, 227, 229, 230
 pectoral. See Moche bead work
 Piura Valley, 203
 post, 25, 45, 46, 48, 49, 50, 51, 52, 53, 54, 55, 63, 149, 193
 post hole, 45, 52
 Pyramids at Moche, 46

 quartz beads. See Moche bead work

 radiocarbon samples, 197, 198
 rattle, 117, 208
 ray, 82
 reclining figure. See Moche ceramics
 red pigment, 98
 retainer burial, 34, 35, 65, 66, 67, 129, 150, 152, 153, 156, 169, 172, 173
 rock crystal beads. See Moche bead work
 roof beam, 20, 21, 24, 25, 32, 33, 34, 43, 57, 68, 70, 71, 146, 149, 193, 200, 201

 scepter. See Moche metal work
 seahorse, 82, 120, 121, 123, 125, 147
 sea lion, 124, 125, 133, 183, 184, 196
 seated figure, 121
 serpent, 179
 shell beads. See Moche bead work
 shell inlay, 96, 97, 104, 126, 136, 183
 shield, 91, 92, 109, 110, 113, 139, 203, 204
 shirt. See Moche textiles
 Sipan, 119, 146, 147, 202, 204
 skeletons, 14, 26, 27, 34, 35, 65, 98, 174, 175
 age, 27, 29, 32, 33, 65, 110, 130, 149, 151, 162, 172, 179
 children, 149, 150, 151, 152, 153, 155, 156
 female, 33, 34, 35, 65, 66, 67, 149, 172, 173
 male, 27, 29, 30, 32, 110, 111, 129, 151, 152, 156, 169, 172, 173, 176, 178
 partial, 14, 26, 27, 32, 33, 34, 35, 37
 principal figure, 102, 109, 110, 111, 112, 162, 176, 178, 181, 195, 196, 197, 202, 203
 stature, 27, 110, 130, 162, 181, 202, 203, 209
 pathology, 181, 202, 203, 209
 spatula-like blade, 116
 spear point. See Moche metal work
 spear shaft. See wood shaft
 spear thrower, 109, 110, 155, 174
 spindle whorl, 34, 35, 149, 151, 173
 Spondylus shell, 3, 104, 105, 183, 190, 196, 208, 211
 stone, 30, 31
 stone inlay, 106, 109, 161
 stirrup spout bottle. See Moche ceramics

textiles. See Moche textiles
truncated pyramid, 10
tumi. See Moche metal work
tweezers. See Moche metal work
ulluchu, 118, 119

unlooted tomb, 16, 17. See also Huaca dos Cabezas pyramid Tombs A, B, 1 , 2,
and 3

Viru, 147
Viru Valley, 146

war club, 111, 113, 117, 139, 142, 203, 204
warrior, 91, 95, 104, 105, 108, 146
wood
 beam. See roof beam
 dart, 143
 drum-shaped figure, 118, 145
 post. See post
 post hole. See post hole
 spear thrower, 115, 145, 196
 shaft / handle, 77, 110, 114, 115, 116, 136, 155, 175
 spear, 114, 142. See also Moche metal work
 staff, 117, 118, 142, 143
 war club 139, 142
wool. See Moche textiles



Christopher B. Donnan is Professor of Anthropology at UCLA. Considered one of the world's foremost authorities on the Moche, he has studied Moche civilization for more than four decades, combining the systematic analysis of Moche art with numerous archaeological excavations in Peru. His many publications include *Moche Portraits from Ancient Peru*, *Moche Fineline Painting: Its Evolution and Its Artists* (with Donna McClelland), *Royal Tombs of Sipán* (with Walter Alva), *Ceramics of Ancient Peru*, and *Moche Art of Peru: Pre-Columbian Symbolic Communication*.

"This work is a detailed description and analysis of a number of elaborate burials from Dos Cabezas. This is Donnan at its best, and at the top of his game. In my point of view, it represents the most important contribution on the subject after the *Royal Tombs of Sipán*. It will provide a wealth of information for people interested in Moche religion and cosmology."

— Steve Bourget, The University of Texas at Austin

