

Lawrence Berkeley National Laboratory

Recent Work

Title

DELAY LINE MWPC HAZARD SIGNALS INSPECTOR

Permalink

<https://escholarship.org/uc/item/7sh2v05t>

Author

Turner, D.B.

Publication Date

1975-11-01

U U 4 5 3 3 0 4 9

Presented at the IEEE Nuclear Science
Symposium, San Francisco, CA,
November 19-21, 1975

LBL-4622 c.1
HEPL-770

DELAY LINE MWPC HAZARD SIGNALS INSPECTOR

D. B. Turner, F. Kirsten,
Z. G. T. Guiragossian, and R. Schilling

November 1975

Prepared for the U. S. Energy Research and
Development Administration under Contract W-7405-ENG-48

For Reference
Not to be taken from this room

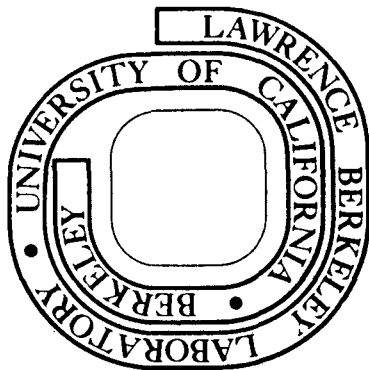

LBL-4622
c.1

DISCLAIMER

This document was prepared as an account of work sponsored by the United States Government. While this document is believed to contain correct information, neither the United States Government nor any agency thereof, nor the Regents of the University of California, nor any of their employees, makes any warranty, express or implied, or assumes any legal responsibility for the accuracy, completeness, or usefulness of any information, apparatus, product, or process disclosed, or represents that its use would not infringe privately owned rights. Reference herein to any specific commercial product, process, or service by its trade name, trademark, manufacturer, or otherwise, does not necessarily constitute or imply its endorsement, recommendation, or favoring by the United States Government or any agency thereof, or the Regents of the University of California. The views and opinions of authors expressed herein do not necessarily state or reflect those of the United States Government or any agency thereof or the Regents of the University of California.

DELAY LINE MWPC HAZARD SIGNALS
INSPECTOR*

D.B. Turner and F. Kirsten
Lawrence Berkeley Laboratory
University of California
Berkeley, California 94720

and

Z.G.T. Guiragossian and R. Schilling**
High Energy Physics Laboratory
Stanford University
Stanford, California 94305

ABSTRACT

The Hazard Inspector is a CAMAC module which divides a MWPC delay line into 8 independent signal monitor and control segments. Independent control effectively reduces delay line occupation time and cuts the number of background and non-trigger particles accepted by the 4XQT charge-time-pulse-width digitizer, a device presented in a separate communication. Only segments containing legitimate information are digitized. Non-trigger related events are gated out at the digitizer, and contaminating hits are noted for computer correction.

INTRODUCTION

The Hazard Signals Inspector is a CAMAC device which monitors the time and location of events on a delay line MWPC. To be properly digitized, a hit on a delay line chamber must occur in coincidence with the trigger, since hits before and after the trigger generate wrong position information with respect to the trigger. The space-time region in which a hit could fall to be wrongly digitized is called the occupation zone of the chamber. The Hazard Inspector's job is to reduce or eliminate the positional ambiguity which multiple delay line hits generate. The Hazard Signals Inspector performs two functions to delay line information:

1. The Inspector receives trigger signals from 8 separately controlled segments of the delay line MWPC. By only permitting analysis of those segments containing legitimate hits, the Hazard Signals Inspector reduces the effective occupation time of the delay line by a factor of eight.

*Work supported by the National Science Foundation (Grant GP-38611) and the Energy Research and Development Administration.

**Present address: TRW Systems, Redondo Beach, California 90278.

This yields the same advantage as decreasing the delay of the line by eight without the associated expense of increasing the time resolution of the delay line digitizer.

2. The Inspector monitors the hits in each segment of the delay line and classifies them as good (i.e., coincident with the internally adjustable trigger window) or bad. For the occupation time surrounding each event trigger, the Hazard Signals Inspector tabulates which segments had only bad hits, which segments only good hits, and which segments had both. This information for the eight segments is presented to CAMAC as a 16 bit word. An additional bit summarizes the event as good if no bad bits were encountered.

The ability of the Hazard Signals Inspector to reduce the number of wrongly digitized events is particularly designed for use¹ in FERMILAB experiment E-192/454. For these experiments, we have created a special delay line digitizer², the 4XQT. This device digitizes above set threshold levels the center of gravity, charge, and charge profile for up to four particles or electromagnetic showers intercepted by a delay line MWPC. Because of the fixed capacity of the digitizer and the possibility of high background rates, the Hazard Signals Inspector is a vital filter of MWPC events.

SYSTEMS CONNECTION

One Hazard Inspector is used with each delay line plane. The low voltage cathodes of a MWPC are tied to a low distortion delay line with a delay of 5 nsec/tap. An amplifier on one end of the delay line drives signals with 100:1 dynamic range to the Linear Gate of the 4XQT Digitizer. The anode wires of the chamber are grouped in 8 segments, separately amplified. These serve as triggers to the Prompt Generator, a timing discriminator which signals the Master Trigger. The amplified segment outputs are also delayed enroute to the Hazard Inspector, where they are timed against the Master Trigger. The Hazard Inspector output controls the Linear Gate of the 4XQT. This system is shown schematically in Figure 1.

HAZARD INSPECTOR OPERATION

Consider the picture of delay line space-time in Figure 2. The course of every particle appearing on the delay line begins on the delay line, at position X_E and time t_0 and ends on the delay line amplifier at $X = X_0$ at time $t_1 = t_0 + \tau$ where τ is the propagation delay. The trajectory toward the right end is a diagonal line whose slope is the propagation velocity of the delay line. For an event at t_0 on an unguarded (without Hazard Inspector) delay line the occupation zone is the parallelogram shown in Figure 2. A hit in this zone at any time other than t_0 will appear at the amplifier and will give a false position reading with respect to t_0 , the event trigger time. One way to detect this non-trigger event as such is to amplify both ends of the delay line and pair arrival times of pulses. Correlating arrival times by computer will solve for legitimate hits for a reasonable number of hits per trigger. In this case, however, because detailed charge and charge profile information is needed from the delay line, the 4XQT digitizer is used. Its fixed capacity makes computer filtering ineffective. Instead, as noted above, the delay line's occupation zone is divided into 8 smaller zones shown in Figure 3. Ease of design dictates these hazard zones be rectangles rather than parallelograms. The total occupation zone for a given hit is now 1/8 the area for an unguarded delay line.

A block schematic of the Hazard Inspector is shown in Figure 4. Consider an event at $t = t_0$, $X = X_2$ on the delay line. This is shown on the timing diagram of Figure 3. Notice that in this example two hits occurred earlier at $t = t_1$ at $X = X_4$ and $X = X_5$. The hit at X_4 is a Hazard or bad hit. It is noted for computer filtering. The hit at X_5 is filtered out by the Hazard Inspector, although it would be a hazard for an unguarded delay line.

Good Hits

The good hit at X_2 is converted to a TTL pulse by the Anode Segment #2 Amplifier. After a fixed delay it is passed by the EVENT TRIGGER GATE, since it was formed in coincidence with the TRIGGER. The output of that gate fires a one-shot whose period is $\tau/8$, where τ is the total delay of the delay line. At the end of that period, a Trailing Edge Differentiator (TED) strobes the storage flip flop, recording the fact that a good event occurred on that segment. The trailing edge also goes to the GOOD EVENT OR GATE, which in turn triggers the DELAY LINE INSPECTION GATE to the 4XQT. Note on Figure 3 that hit X_2 arrives at the amplifier (and Linear Gate) while the DELAY LINE INSPECTION GATE (DLIG) is high. Thus the hit is digitized.

Bad Hits

Hit X_4 also arrives while the DLIG is high. So, it too is digitized. This is a bad event, a hit not coincident with the trigger. Since it fell in a hazard or occupation zone, there is no way to avoid digitizing it. However, the Inspector can note that it is there.

The BAD EVENT COINCIDENCE WINDOW starts at the same time as the DLIG. When X_4 occurred at time t_1 , it passed the EVENT TRIGGER GATE and fired #4 BAD EVENT DELAY. The trailing edge of that delay is passed by the #4 BAD COINCIDENCE GATE and strobes the

#4 BAD EVENT FF. This notes the occurrence of a hazard in Segment #4, and sets the BAD EVENT summary bit.

The hit X_5 triggers its #5 BAD EVENT DELAY. When that delay times out, the BAD EVENT COINCIDENCE WINDOW is low, and so the hit goes completely unrecorded.

Design and Construction

The Hazard Inspector is housed in a double width CAMAC module. It accepts as inputs the eight anode segments of a delay line MWPC and the EVENT TRIGGER. An internally adjustable EVENT TRIGGER WINDOW controls the chamber jitter acceptance. Outputs from the front panel are the DELAY LINE INSPECTION GATE and a test-timing port. The CAMAC outputs are a 16 bit word which states good and bad hits on each segment, and one bit summary of the event.

Care has been taken to correctly define and store hits when high rates are encountered. Multiple triggers of the delays are acceptable. Test and calibration features are included. The module is self-triggering, and needs CAMAC attention only to transfer data to the computer storage.

ACKNOWLEDGEMENTS

Thanks are due to members of LBL's Physics Systems Instrumentation Group who gave material and spiritual support to this project, including M. Wolverton, K. Lee, S. Olson, and C. Whiteside.

REFERENCES

1. S.R. Olson, et al., "A MWPC Instrumentation System with Small Dead-Time and with Provision for Automatic Testing and Calibration," published in these proceedings.
2. Kai L. Lee, et al, "Four Deep Charge-Time and Pulse Width Scaling Discriminator for Delay Line MWPC's," published in these proceedings.

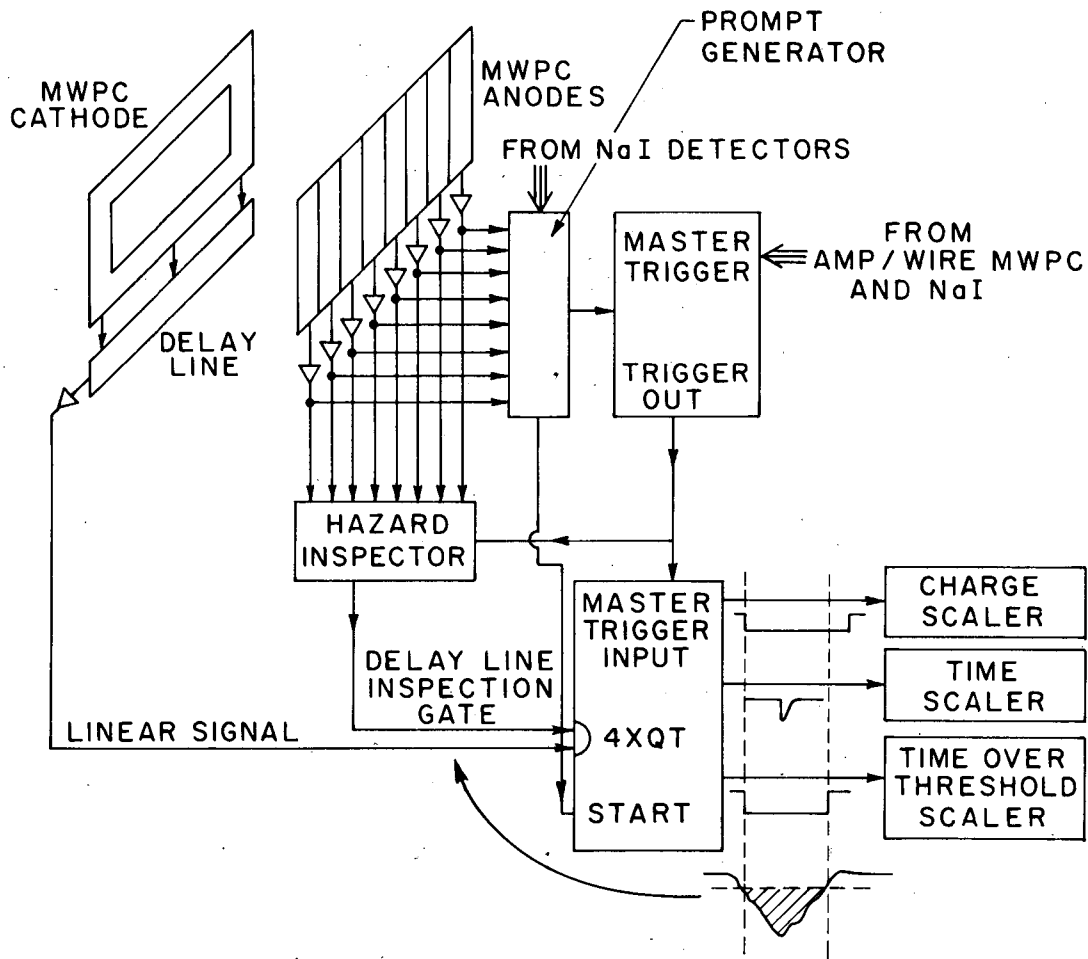

Fig. 1 MWPC Using delay line readout with Hazard Signals Inspector.

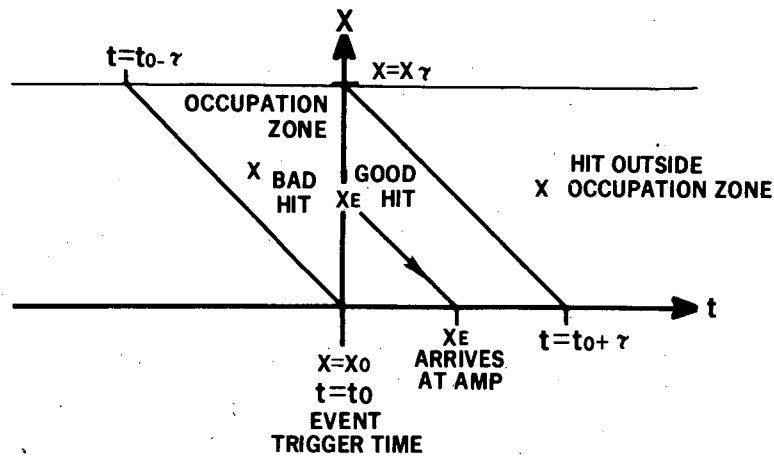

Fig. 2 Delay Line space-time diagram.

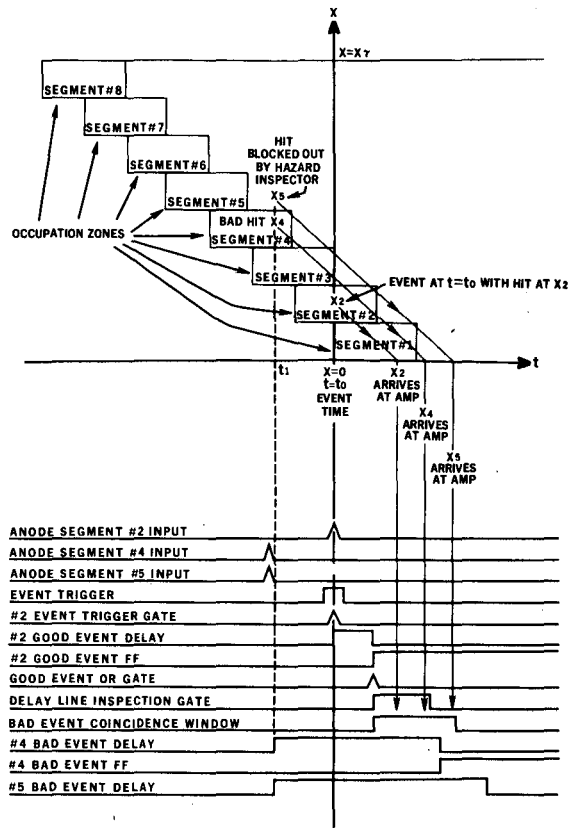

Fig. 3 Hazard Signals Inspector time and space signal relationships.

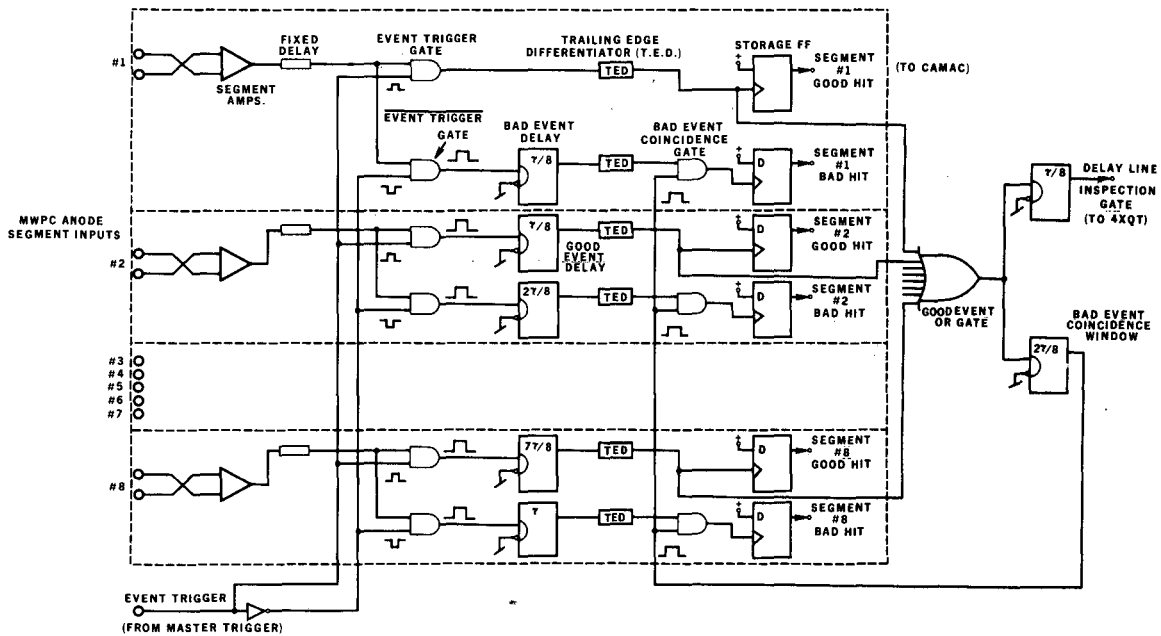

Fig. 4 Hazard Inspector block diagram.

LEGAL NOTICE

This report was prepared as an account of work sponsored by the United States Government. Neither the United States nor the United States Energy Research and Development Administration, nor any of their employees, nor any of their contractors, subcontractors, or their employees, makes any warranty, express or implied, or assumes any legal liability or responsibility for the accuracy, completeness or usefulness of any information, apparatus, product or process disclosed, or represents that its use would not infringe privately owned rights.

TECHNICAL INFORMATION DIVISION
LAWRENCE BERKELEY LABORATORY
UNIVERSITY OF CALIFORNIA
BERKELEY, CALIFORNIA 94720