

# UC Irvine

## UC Irvine Electronic Theses and Dissertations

### Title

Applying Smart Grid Technologies to the Secondary Distribution System

### Permalink

<https://escholarship.org/uc/item/7sv9817t>

### Author

Cinar, Renee

### Publication Date

2014

Peer reviewed|Thesis/dissertation

UNIVERSITY OF CALIFORNIA,

IRVINE

**Applying Smart Grid Technologies to the Secondary Distribution System**

THESIS

submitted in partial satisfaction of the requirements

for the degree of

MASTER OF SCIENCE

in Mechanical and Aerospace Engineering

by

Renee Gail Çınar

Thesis Committee:

Professor G. Scott Samuelsen, Chair

Professor Jacob Brouwer

Professor Faryar Jabbari

2014



## **DEDICATION**

To my husband, my best friend and love of my life

To my children, your unconditional love and acceptance gives my life meaning and inspires me  
to be the best I can be

## TABLE OF CONTENTS

<b>LIST OF FIGURES .....</b>	<b>viii</b>
<b>LIST OF TABLES .....</b>	<b>x</b>
<b>LIST OF ACRONYMS .....</b>	<b>xi</b>
<b>ACKNOWLEDGMENTS .....</b>	<b>xiii</b>
<b>ABSTRACT .....</b>	<b>xiv</b>
<b>1 INTRODUCTION .....</b>	<b>1</b>
1.1 GOALS.....	3
1.2 OBJECTIVES.....	3
<b>2 BACKGROUND .....</b>	<b>4</b>
2.1 THE UNITED STATES ELECTRIC POWER SYSTEM .....	4
2.1.1 Distribution system.....	5
2.2 AGING ELECTRIC POWER SYSTEM INFRASTRUCTURE.....	8
2.3 SMART GRID .....	9
2.3.1 Smart Grid Benefits.....	10
2.3.2 Smart Grid on the Distribution System.....	10
2.4 ENERGY INDPENDENCE AND SECURITY ACT OF 2007 .....	11
2.5 THE AMERICAN REINVESTMENT AND RECOVERY ACT OF 2009 .....	13
2.5.1 Smart Grid Demonstration Program.....	14

2.5.2	Irvine Smart Grid Demonstration .....	14
2.6	TODAY’S SMART GRID VISION.....	17
2.7	DISTRIBUTED ENERGY RESOURCES (DER) .....	17
2.7.1	Distributed Generation (DG).....	18
2.7.2	Demand Response (DR) .....	18
2.7.3	Solar Energy .....	19
2.7.4	Energy Storage .....	19
2.8	PLUG-IN ELECTRIC VEHICLES .....	20
2.9	COMMUNICATIONS.....	21
2.10	ADVANCED METERING INFRASTRUCTURE (AMI).....	22
2.10.1	Net Energy Metering.....	23
2.11	RESEARCH GAP .....	23
<b>3</b>	<b>APPROACH .....</b>	<b>25</b>
3.1	TASK 1: Characterize Key Stakeholders.....	25
3.2	TASK 2: Categorize and Summarize Relevant Standards .....	25
3.3	TASK 3: Develop Dynamic Model .....	26
3.4	TASK 4: Obtain Dynamic Load and Generator Data.....	27
3.5	TASK 5: Analyze “Smart” Secondary Circuit Power Management Scenarios .....	28
<b>4</b>	<b>TASK 1 RESULTS: KEY STAKEHOLDERS.....</b>	<b>29</b>

4.1	CONSUMERS.....	29
4.2	ENVIRONMENTAL GROUPS.....	30
4.3	UTILITIES.....	31
4.4	REGULATORS.....	32
4.5	POLICY MAKERS.....	33
4.6	TECHNOLOGY PROVIDERS.....	35
<b>5</b>	<b>TASK 2 RESULTS: RELATED LAWS AND RELEVANT STANDARDS.....</b>	<b>36</b>
5.1	IMPORTANCE OF STANDARDS.....	36
5.2	NATIONAL INSTITUTE OF STANDARDS AND TECHNOLOGY.....	37
5.3	CALIFORNIA’S RENEWABLE PORTFOLIO STANDARD.....	37
5.4	CALIFORNIA STATE POLICY OF NET ENERGY METERING.....	38
5.4.1	Net Energy Metering Implications.....	39
5.5	ELECTRIC RULE 21.....	40
5.6	IEEE Std. 1547-2003.....	41
5.6.1	Recommended revisions to the standard.....	43
5.7	UL1741.....	45
<b>6</b>	<b>TASK 3 RESULTS: MODEL DEVELOPMENT.....</b>	<b>46</b>
6.1	MODEL OVERVIEW.....	46
6.2	SECONDARY DISTRIBUTION TRANSFORMER.....	49

6.3	ROOFTOP SOLAR PHOTOVOLTAIC SYSTEM.....	50
6.4	ENERGY STORAGE .....	51
6.4.1	Residential Energy Storage .....	52
6.4.2	Community Energy Storage .....	53
6.5	PLUG-IN ELECTRIC VEHICLE CHARGING .....	54
6.6	RESIDENTIAL LOAD.....	55
<b>7</b>	<b>TASK 4 RESULTS: OBTAIN DYNAMIC LOAD AND GENERATOR DATA.....</b>	<b>56</b>
7.1	TRANSFORMER DATA.....	56
7.2	RESIDENTIAL LOAD DATA.....	59
7.3	SOLAR .....	65
7.4	EV CHARGING ON CAMPUS & AT HOME .....	68
<b>8</b>	<b>TASK 5 RESULTS: SMART GRID TECHNOLOGY MANAGEMENT SCENARIOS.....</b>	<b>73</b>
8.1	SINGLE FAMILY HOME WITH ROOFTOP SOLAR AND ENERGY STORAGE.....	74
8.2	RESIDENTIAL STREET WITH HIGH PENETRATION OF SOLAR, ELECTRIC VEHICLE CHARGING & INDIVIDUAL ENERGY STORAGE.....	79
8.3	RESIDENTIAL STREET WITH HIGH PENETRATION OF SOLAR, ELECTRIC VEHICLE CHARGING, AND SHARED ENERGY STORAGE .....	83
8.3.1	Load Following Discharge .....	83
8.3.2	Constant Power Discharge.....	84



<b>9</b>	<b>SUMMARY AND CONCLUSIONS .....</b>	<b>86</b>
9.1	SUMMARY .....	86
9.2	CONCLUSIONS .....	87
9.3	RECOMMENDATIONS FOR FUTURE WORK .....	90
<b>10</b>	<b>REFERENCES .....</b>	<b>93</b>

## LIST OF FIGURES

Figure 1. Electric power system structure [7].....	5
Figure 2. Basic distribution system one-line diagram.....	6
Figure 3. Single-phase, three wire secondary distribution transformer .....	7
Figure 4. Irvine Smart Grid Demonstration Project .....	16
Figure 5. High level secondary distribution circuit model .....	48
Figure 6. Padmount, single-phase, three wire secondary distribution transformer with open cover to show measurement equipment .....	49
Figure 7. Solar panels installed at a residence.....	50
Figure 8. Residential rooftop solar PV system block diagram .....	51
Figure 9. High level rooftop PV system diagram.....	51
Figure 10. Rogowski coil CTs installed on a padmount, secondary distribution transformer.....	56
Figure 11. Initial ISGD transformer current measurements.....	57
Figure 12. Measured, 5 minute resolution, daily, CES transformer load profiles .....	58
Figure 13. Measured, 3 second resolution, residential daily load profiles .....	60
Figure 14. Measured, 3 second resolution, weekday, residential load profile .....	61
Figure 15. Measured, 3 second resolution, daily, refrigerator load profile .....	62
Figure 16. Measured, 3 second resolution, gas clothes dryer load profile .....	63
Figure 17. Measured, 3 second resolution, clothes washer load profile .....	64
Figure 18. PV profile for a sunny day, 1 minute resolution .....	66
Figure 19. PV profile for a cloudy day, 1 minute resolution.....	67
Figure 20. PV profile for a cloudy day, 5 minute resolution.....	68

Figure 21. SAE J1772 PEV conductive charge coupler .....	69
Figure 22. PEV charging coupler in use.....	69
Figure 23. Level 1 Prius PHEV charging events at home.....	71
Figure 24. Zoomed in view of single charging event .....	71
Figure 25. Voltage measured at outlet during charging events .....	72
Figure 26. Sample power demand and generation profiles at one home.....	74
Figure 27. Net load profile for one home .....	75
Figure 28. RESU charge/discharge cycle using load following time based control .....	76
Figure 29. Resulting load profile of home with load following RESU .....	77
Figure 30. RESU 2 kW constant power discharge strategy.....	78
Figure 31. RESU sized to match net solar production .....	79
Figure 32. Load profiles for a block 7 of homes with rooftop solar and EV charging .....	80
Figure 33. Modeled electric vehicle charging events .....	81
Figure 34. Load profile at transformer for block with individual energy storage units .....	82
Figure 35. CES battery load following discharge beginning at 6pm .....	84
Figure 36. CES constant power discharge scenarios beginning at 6PM .....	85
Figure 37. CES constant power discharge scenarios beginning at 5PM .....	85

## LIST OF TABLES

Table 1. Summary of technologies modeled on each block.....	27
Table 2. Summary of total energy consumed in home, per day, for 1 week .....	61
Table 3. Total energy consumed by refrigerator for 5 days .....	62
Table 4. Total energy consumed for 5 separate clothes drying events.....	64
Table 5. Total energy consumed for 3 separate clothes washing events .....	65
Table 6. Standard PEV charging levels .....	69

## LIST OF ACRONYMS

AMI	advanced metering infrastructure
AC	alternating current
ANSI	American National Standards Institute
ARRA	American Reinvestment and Recovery Act
A	Ampere, amp
CAISO	California Independent System Operator
CPUC	California Public Utilities Commission
CO <sub>2</sub>	carbon dioxide
CES	community energy storage
CT	current transformer
DER	distributed energy resource
DG	distributed generation
DOE	Department of Energy
EISA	Energy Independence and Security Act
EPS	electric power system
EV	electric vehicle
EVSE	Electric vehicle supply equipment
FERC	Federal Energy Regulatory Commission
G	Suns
HAN	home area network
IEC	International Electrotechnical Commission
IEEE	Institute of Electrical and Electronic Engineers
IEEE-SA	Institute of Electrical and Electronic Engineers – Standards Association
kWh	kilowatt-hour
kV	Kilovolt
kVA	kilovolt-Amperes
LAN	local area network
LTC	load tap changer
MPPT	Maximum Power Point Tracking
NARUC	National Association of Regulatory Commissioners
NEM	net energy meter/metering
NEMA	National Electrical Manufacturers Association
NIST	National Institute of Standards and Technology
OEDER	Office of Electric Delivery and Energy Reliability
PCC	point of common coupling
PPA	Power Purchase Agreement
PNNL	Pacific Northwest National Laboratory
PV	photovoltaic
PEV	plug-in electric vehicle
PHEV	plug-in hybrid electric vehicle
PUC	Public Utilities Code

PURPA	Public Utility Regulatory Policies Act
RESU	residential energy storage unit
RPS	Renewable Portfolio Standard
RMS	root mean square
SAE	Society of Automotive Engineers
SCE	Southern California Edison
SGDP	Smart Grid Demonstration Program
SGIG	Smart Grid Investment Grant
TOU	Time of use
UL	Underwriters Laboratories
V	Volt
V2G	vehicle-to-grid
ZNE	zero net energy

## **ACKNOWLEDGMENTS**

Thank you to my Faculty Advisor Scott Samuelsen, Co-Advisor Jack Brouwer and Thesis Committee Member, Faryar Jabbari, for your thoughtful advice and support. I am eternally grateful for the guidance and constructive feedback that I received from the Advanced Power and Energy Program leadership team.

Thank you to Russ Neal, Jerry Thode, Ed Kamiab, Chris Clarke, and Daryl Coleman of Southern California Edison for taking time out of your busy schedules to share your electric power system knowledge and to offer advice and suggestions on my work.

Thank you to all the students at APEP for your never ending enthusiasm and youthful spirit. Special thanks go to Josh Payne, Josh Eichman, Allison Auld, and Fei Gu for your helpful suggestions and assistance in flushing out ideas. Also, I want to give a shout-out to the ladies of APEP for your greatly appreciated, non-judgmental friendship.

The author expresses appreciation to Southern California Edison and their role in establishing financial support through funding awarded by the U.S. Department of Energy, Award Number DE-OE0001999, under which this research was conducted.

Peace!

# **ABSTRACT**

## **Applying Smart Grid Technology to the Secondary Distribution System**

By: Renee Gail Çınar

Masters of Science in Mechanical and Aerospace Engineering

University of California, Irvine, 2014

Professor G. Scott Samuelson, Chair

Today's aging electric delivery infrastructure is undergoing an extreme makeover. The current system has inefficiencies, is congested and unable to meet future power reliability, quality, sustainability (e.g., more renewable power) and security needs. The massive effort to modernize the nation's electricity delivery system is collectively known as the "Smart Grid." Transition to a smarter grid will occur over time.

This research addresses one area of electric power system modernization, namely the impacts that high penetrations of distributed energy resources (DER), such as solar and batteries, and plug-in electric vehicles (PEVs) could have on the distribution system by (1) evaluating the effect of introducing large amounts of DER and PEV charging on a secondary distribution circuit and (2) developing, applying and evaluating smart grid management scenarios which can reduce consumer electricity costs and flatten residential load profiles.

The improved load profiles presented herein demonstrate that traditional residential load profiles can be purposefully reshaped when rooftop solar, energy storage, and plug-in electric vehicles are introduced into the circuit. Through various battery charging and discharging



scenarios and controlled electric vehicle charging, residential loads can be reduced to almost zero, flattened, or behave as a distributed generator. By allowing excess solar generation to flow back onto the grid or dispatching batteries during peak load times, the load profile of an individual home or secondary distribution transformer can be altered in a manner that benefits the distribution grid.

# 1 INTRODUCTION

Electricity is a staple of modern life. A successful economy, national security, public health and public safety all depend on an inexpensive and reliable supply of electric power. With even short disruptions in electric service, communities struggle to meet their basic needs.

Over the past 100 years the United States electric power system has grown into 1 million megawatts of generation capacity, 200,000 miles of high voltage transmission lines, and 5.5 million miles of distribution lines [1]. The National Academy of Engineering deemed electrification as the number one engineering achievement of the 20<sup>th</sup> century [2].

Since its birth, the electric power system has amassed an estimated total asset value that exceeds \$800 billion [3]. In 2012, 3.7 trillion kWh of electricity was consumed by the United States [4]. Today, 40% of the energy consumed in the U.S. is used to produce electricity [1]. Nationwide, the electricity generation is expected to increase 30% by the year 2035 [5].

Much of the infrastructure put in place since the birth of the electric power system is still in use today. The typical U.S. power plant was built in the 1960s using electro-mechanical parts designed and validated many years earlier [6]. As the demand for electricity rises, there is a pressing need to modernize the existing system. In addition to greater demand, increased use of power electronics has reduced the tolerance for outages and power quality disturbances, such as variations in voltage and frequency levels. Growing interest in distributed energy resources (distributed generation, energy storage, and demand response programs)

necessitates new interconnection requirements to ensure a safe and reliable electric power system.

The path to a smarter grid will, over time, transform the way electricity is generated, transmitted and delivered. Technologies developed in response to efforts to modernize the grid will fundamentally change how the distribution portion of the system operates. Distributed energy resources (DERs), designed to generate power closer to the load, will offset the need to build large and expensive centralized power plants while at the same time introduce the potential for bi-directional power flow. As plug-in electric vehicles (PEVs) become more popular, the need to coordinate their charging times becomes imperative. Load shifting to reduce peak and demand response programs can help to mitigate the unintended consequences of high penetrations of DER and EV charging on the distribution circuit.

This research addresses some of the challenges associated with introducing large amounts of DER and EV charging on the secondary distribution circuit. Additionally, smart grid management scenarios are presented to demonstrate strategies to flatten the diurnal load profile as seen by the secondary distribution transformer. Also included is an examination of the stakeholders affected by the smart grid evolution. An investigation of the recent policies and relevant standards important in shaping how the future distribution system will operate are also discussed.

## 1.1 GOALS

The goals of this Thesis are to (1) establish the impact of introducing large amounts of DER and PEV charging on the secondary distribution circuit and (2) identify smart grid management scenarios which can reduce consumer electricity costs and levelize residential load profiles using emerging smart grid technologies.

## 1.2 OBJECTIVES

The following objectives are addressed to meet the goals of this research:

**Objective 1:** Characterize key stakeholders affected by the installation of distributed energy resources and plug-in electric vehicle charging on the secondary distribution circuit.

**Objective 2:** Investigate federal and state policies and relevant standards important in guiding the role out of smart grid technologies installed on the secondary distribution circuit.

**Objective 3:** Develop a dynamic model in MATLAB/Simulink to simulate the effect of introducing varying levels of rooftop solar, battery energy storage, PEV charging, demand response, and net energy metering on secondary distribution circuits.

**Objective 4:** Obtain dynamic residential plug load, PV generation, and PEV charging power data representative of a typical southern California single family residence for use in the evaluation and analysis of the computer models developed for Objective 3.

**Objective 5:** Identify and apply dynamic secondary circuit power management scenarios using created models and acquired data.

## **2 BACKGROUND**

### **2.1 THE UNITED STATES ELECTRIC POWER SYSTEM**

The U.S. electric power system is an intricately networked, engineering marvel that can generate, transmit, and utilize electric power. Collectively known as “the grid,” it consists of generators that supply electric power to the transmission system, the transmission system to transmit this power to where it is needed, and a distribution system that steps down the voltage to utilization levels and deliveries power. Figure 1 shows the basic arrangement of this system. The system can generate more than 1,000,000 Megawatts of power from over 9,200 generators delivered by more than 300,000 miles of transmission lines [6]. Since the early 1900s, the grid’s main goal has been to keep electricity flowing using a centrally controlled system. As demand for power increases, the system components age, and the reluctance by users to cite new power generating stations and transmission lines continues, the need to modernize the grid and utilize existing electricity supplies more efficiently becomes more pressing. Grid reliability is negatively impacted when system components fail due to age and exposure to extreme weather.

## Basic Structure of the Electric System

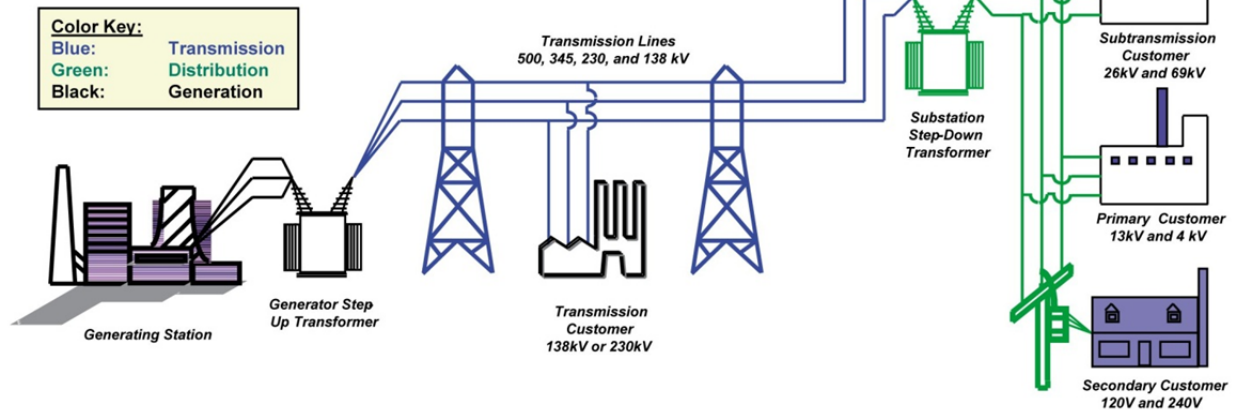

Figure 1. Electric power system structure [7]

Severe weather, the number one cause of power outages in the United States, costs the U.S. billions of dollars annually in lost wages, lost goods production, spoiled food, inconvenience, and damage to the electric system infrastructure. Weather related electricity outages are expected increase as our world's climate continues to warm. Hurricanes, blizzards, floods and other large weather events are expected to increase in frequency and strength as long as greenhouse gas emissions continue to be released into the atmosphere. The nation's aging grid is especially susceptible to these damaging weather events. Upgrading and modernizing electric power system infrastructure is necessary to maintain grid reliability and withstand increasingly severe weather events [8].

### 2.1.1 Distribution system

The distribution system (see Figure 2) begins at the distribution substation and includes all transformers, capacitors, cables and electric meters in between. The distribution substation houses step-down transformers that reduce sub-transmission level voltages (69 to 138 kV) to

primary distribution voltages (2.2 to 46 kV) levels, circuit breakers, surge arrestors, and load tap changers (LTCs). Three-phase distribution lines, known as feeders, are connected to the transformers through protection equipment such as circuit breakers and surge arrestors. Load tap changes (LTCs) and voltage regulators may also be present within the substation. Feeders commonly radiate outward, for miles, until the circuit serves its load [9][10][11][12].

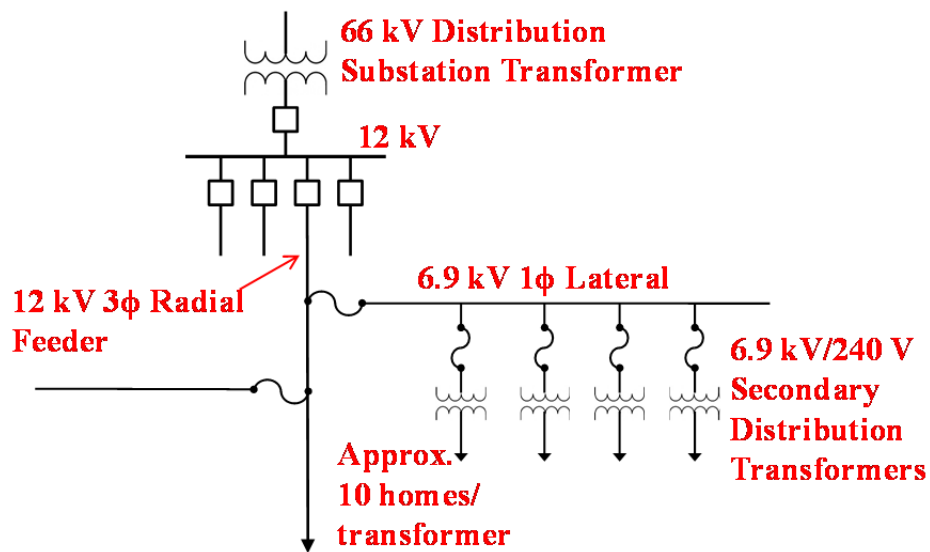

Figure 2. Basic distribution system one-line diagram

Feeder lines are separated into additional three-phase lines or into their individual phase wires by sectionalizing fuses or switches. The single-phase lines are known as laterals. Feeders and laterals supply a local distribution transformer that steps down voltage to utilization levels, and is known as secondary distribution. For instance, a 12 kV, three-phase primary distribution feeder can be separated into 6.9kV, single-phase laterals that feed the service transformers (also known as secondary distribution transformers) [10][11][12].

Rural, small commercial and residential loads are served by either overhead distribution circuits or underground distribution circuits. Rural loads are typically served by a single-phase

primary, with one customer per distribution transformer. Residential loads, on the other hand, are normally served by three-phase, four-wire primary feeders, with single-phase lateral circuits. Small commercial circuits can also be configured in this way [9][11][12].

Circuits connected to the low side of the service transformer are known as secondary distribution circuits. Loads served by the secondary distribution transformer typically connect in a series/parallel configuration with most of the loads connect in parallel [10].

Secondary distribution circuit transformers step down the single-phase 6.9 kV to a utilization voltage, such as 240/120 V, for residential service. These transformers range in size from 10 kVA to 300 kVA. This type of transformer configuration is illustrated in Figure 2. The single-phase distribution transformer is often centered tapped to provide two 120 V low-voltage secondary windings. A third conductor on the low side of the transformer acts as the neutral and is grounded locally to minimize the effect of a short to ground [9].

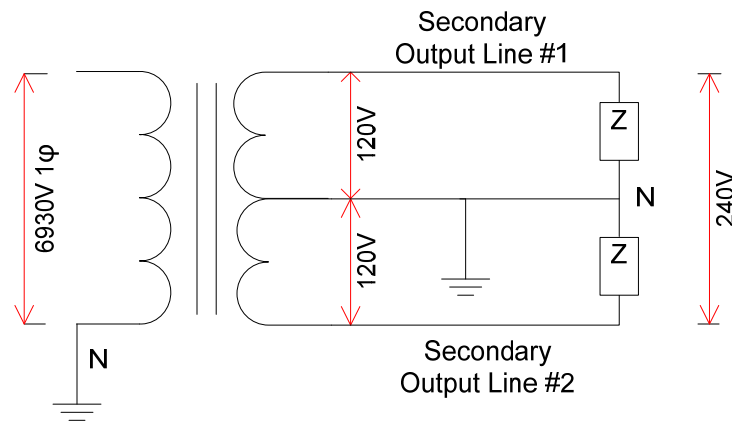

Figure 3. Single-phase, three wire secondary distribution transformer



## **2.2 AGING ELECTRIC POWER SYSTEM INFRASTRUCTURE**

For more than a hundred years, the electric power system has delivered electricity reliably to its users. However, the growth in demand for electricity has outweighed the investment in this critical infrastructure. Since 1982, the demand peak for electricity has grown by 25% percent every year, yet total annual spending for research and development in electric power systems improvements is less than 2% [13][6].

In 2008, the average age of a substation transformer was 42 years. These devices were originally designed to last for 40 years and have now reached the end of their design life. The average U.S. power plant was built in the 1960s using electro-mechanical parts designed and validated many years beforehand. Less than 680 miles of new transmission lines have been built since 2000 [6]. The United States Executive Office of the President estimates the cost of outages related severe weather events to be between \$18 billion and \$33 billion per year [8]. Economic experts estimate that all power outages and power quality issues cost American businesses from \$80 billion to \$135 billion annually [14].

The current electricity delivery system is not capable of serving 21<sup>st</sup> century power needs without significant infrastructure investment and major changes to how it operates.

## **2.3 SMART GRID**

The effort to modernize the nation's electricity delivery system is collectively known as the "Smart Grid." The electric power system is transforming from a traditionally, centrally planned and controlled system, to one that employs large amounts of distributed generation and encourages interaction from electricity consumers. It aims to use existing assets more efficiently and will evolve over time.

Utilities, regulators, policy makers, energy service providers, technology and automation vendors and electricity users are all stakeholders affected by this transformation. Their needs will need to be considered while grid modernization efforts such as two-way communications protocols, plug-and-play capabilities, smart meter deployment, bidirectional power flow, and power flow visualization concepts develop.

The evolution to a smart grid necessitates that distributed energy resources and plug-in electric vehicles integrate seamlessly into the new grid without any decrease in reliability. Concepts and technologies employed by the communications and information technology industries can be applied to the power system to integrate these new subsystems. The emerging smart grid will require electric utilities to form new and innovative business models.

It is important to note that these new power generation systems, smart meters, and plug-in electric vehicles themselves do not constitute the smart grid. Rather, the smart grid includes both the technologies and control methods that facilitate their use.

The Office of Electricity Delivery and Energy Reliability (OEDER) is charged with orchestrating and leading this insurmountable effort. In order to realize this duty, the Office

created a multiagency Smart Grid Task Force responsible for coordinating standards creation, supervising research and development projects, integrating stakeholder agendas, and engaging in public education and outreach [6].

### **2.3.1 Smart Grid Benefits**

Transition to a smarter grid will allow the existing electric power system to operate more securely, reliably, and efficiently. Adapting technology previously developed for the communications and information technology industries will help facilitate this transition.

Potential benefits include reduced transmission and distribution congestion, reduced line losses, and deferred investment in new central generation facilities. New technology developed for the smart grid will enable lower-cost electricity, reduced price volatility, and improved voltage profiles. Additional benefits include reduced central generating station reserve requirements, reduced peak power needs, and environmentally friendly power generation.

### **2.3.2 Smart Grid on the Distribution System**

Nearly 90% of all power outages and instabilities can be traced to the distribution system [15]. Today if there is an outage on the distribution system; utilities are unaware of it until they are notified by affected customers. In addition, distribution grid management has been identified by both the National Institute of Standards and Technology (NIST) and Federal Energy Regulatory Commission (FERC) as one of the priority areas for standards development to ensure system interoperability [16]. The existing infrastructure can be enhanced greatly by implementing methods to manage its assets, automate systems and collect information about the state and health of the distribution system.

Increasing amounts of local power generation and plug-in electric vehicle (PEVs) charging is expected to stress the distribution grid. Large amounts of local generation are expected to result in bidirectional power flow on a system originally designed for one-way power flow. Distribution transformers could be stressed by large clusters of PEVs charging simultaneously. New flow patterns will require changes to system protection and controls [17][18].

Significant amounts of reverse power flow on distribution feeders may cause voltage regulation capabilities to fail, resulting in overvoltage conditions. Control equipment, such as load tap changers, automatic protection coordination schemes, may operate incorrectly or engage more frequently causing the devices to wear prematurely or more frequent power outages. Existing infrastructure may not be sized for the potentially large short circuit currents possible. Distribution feeders could become imbalanced if significant amounts of distributed energy resources on a single-phase radial [18].

## **2.4 ENERGY INDEPENDENCE AND SECURITY ACT OF 2007**

The Energy Independence and Security Act of 2007 (EISA) enacted by the 110<sup>th</sup> U.S. Congress and signed into law by President George W. Bush on December 19, 2007, is legislation that aims to move the U.S. toward greater energy independence and energy security [19]. The energy act requires increased production of fuels from renewable methods, to increase the energy efficiency of consumer products, buildings and vehicles and encourages research on greenhouse gas capture and storage. U.S. policy on the modernization of the nation's electric power system is detailed in TITLE XIII—Smart Grid of this Act.

Section 1301 of TITLE XIII institutes federal policy to modernize the entire electric power system in order to maintain system reliability, assure system security, accommodate future demand, enable deployment and integration of smart grid technologies such as distributed generation, demand response, and plug-in electric vehicles.

Section 1302 requires the Assistant Secretary of the Office of Electric Delivery and Energy Reliability (OEDER), an office within the U.S. Department of Energy (DOE), together with the Smart Grid Task Force and Smart Grid Advisory Committee (both established in Section 1303) to report regularly to Congress on smart grid projects in progress throughout the U.S. and describe any regulatory or governmental obstacles discovered.

The U.S. Department of Energy is directed to engage in and provide 50% cost share for smart grid technology research, development and demonstration projects in Section 1304.

Section 1305 gives the Director of the National Institute of Standards and Technology (NIST) responsibility to coordinate development of a smart grid interoperability framework that contains protocols and standards for emerging smart grid technology.

The U.S. Department of Energy is authorized in Section 1306 to create grant programs that provide 20% cost share for smart grid research. This amount is later amended in 2009, by the Recovery Act, to allow for 50% cost share. States are obliged to encourage utilities to invest in smart grid technologies and enable the utilities to recover their costs from ratepayers in Section 1307.

Section 1307 serves as an amendment to the Public Utility Regulatory Policies Act of 1978 (PURPA).

Section 1308 directs the DOE to conduct a study on the current laws and regulations associated with siting privately owned electric wires connected to combined heat and power facilities.

The DOE is required to study the security needs of a Smart Grid to insure its ability to resist attacks in Section 1309.

## **2.5 THE AMERICAN REINVESTMENT AND RECOVERY ACT OF 2009**

The American Reinvestment & Recovery Act of 2009 (ARRA of 2009), enacted by 111<sup>th</sup> United States Congress and signed into law by President Barak Obama on February 17, 2009, is an economic stimulus package legislated to inject money into the struggling United States Economy during the height of The Great Recession [20][21]. Recovery Act of 2009 appropriations were budgeted to preserve and create new jobs; invest in infrastructure, education, science, and energy efficiency; provide financial assistance to the unemployed; and help stabilize State and local governments.

At the time the bill was signed, the stimulus package was estimated to cost U.S. taxpayers \$787 billion. Funding related to energy infrastructure totaled \$21.5 billion. The U.S. Department of Energy Office of Electricity and Energy Reliability received \$4.5 billion in funds to improve electricity delivery and reliability through modernization of the nation's electric power system and implement programs authorized under Title XIII of EISA 2007. Approximately \$27.2 billion was appropriated for investments in energy efficiency and renewable energy research.

To further encourage growth of the U.S. economy, a “Buy American” provision was included in the bill. This requirement insured that projects awarded for public buildings or public works projects procured iron, steel and other manufactured goods from U.S. suppliers [20].

### **2.5.1 Smart Grid Demonstration Program**

The Smart Grid Demonstration Program (SGDP) is authorized by Energy Independence and Security Act of 2007 and supported by Recovery Act appropriated funds. This grant program aims to spur investment in the modernization of both the transmission and distribution systems, smart grid technologies, tools and techniques which facilitate the creation of an American smart grid.

Section 1304 of EISA of 2007 enables Smart Grid regional demonstration projects to facilitate, investigate, and demonstrate the system level feasibility of emerging technologies. The demonstration projects are required to engage local electric utilities and will provide up to 50 percent share of cost. Thirty-two projects, totaling \$1.6 Billion (with a federal share of approximately \$600 million), were awarded focusing on two main areas: Smart Grid Regional Demonstrations and Energy Storage Demonstrations [22].

### **2.5.2 Irvine Smart Grid Demonstration**

Research discussed in this Thesis is supported by one of the Smart Grid Regional Demonstrations, namely Southern California Edison’s (SCE) Irvine Smart Grid Demonstration (ISGD) project. ISGD is an \$80 million end-to-end (\$40 million DOE cost share) distribution circuit, smart grid, demonstration project created to investigate the system interactions of a variety of smart grid technologies.

SCE and its partners will install technology onto a distribution circuit in Irvine, California and demonstrate its feasibility. Demonstrations of technology focus on three main areas: 1) energy smart customer devices including smart appliances, residential energy storage, rooftop photovoltaic systems, and energy management systems aimed at realizing zero-net energy capability in the home; 2) a “Year 2020 Distribution System” that contains distribution automation with looped circuit capability, advanced Volt/Var control, advanced distribution equipment, smart meters, utility scale energy storage, and dispatchable renewable distributed generation; and 3) a Secure Energy Network capable of managing and protecting multiple complex communication systems connected between the California Independent System Operator (CAISO) and SCE, field networks and energy management systems in the home.

The goal of this project is to verify that these technologies can operate as designed in the field, to quantify system costs and benefits, perform functional tests and demonstrate zero net energy home capability [22]. Figure 4 illustrates the key technologies studied in the project.



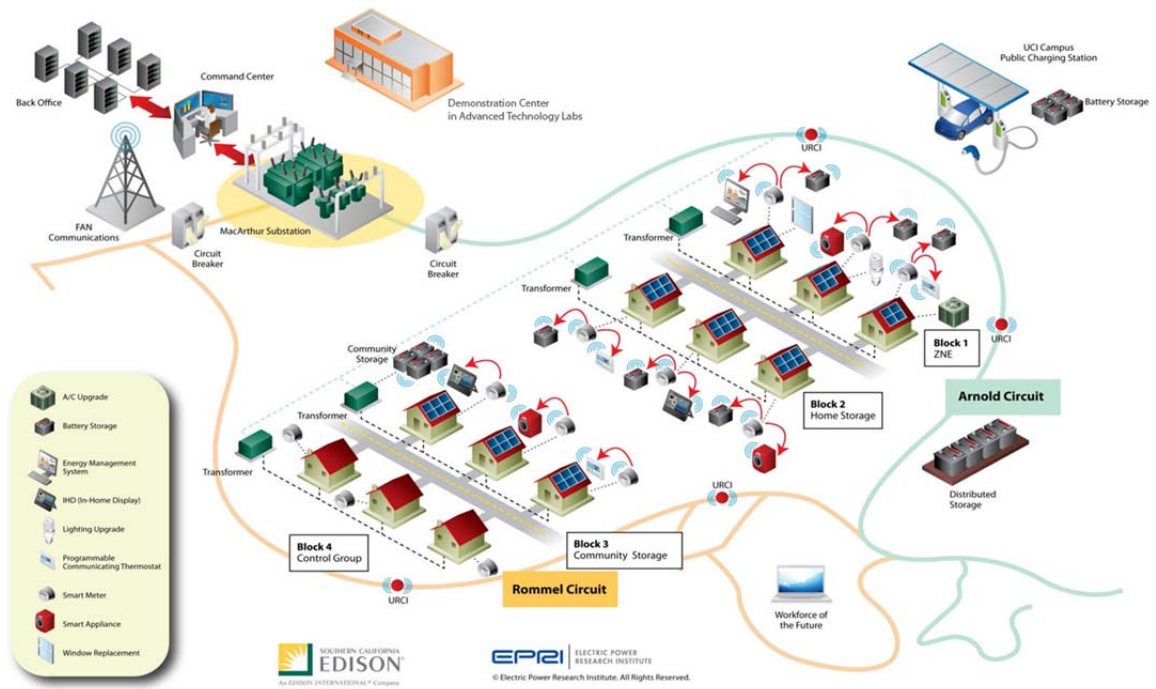

Figure 4. Irvine Smart Grid Demonstration Project

## **2.6 TODAY'S SMART GRID VISION**

The future smart grid is envisioned as reliable, intelligent, green, efficient and self-healing. It will reduce power flow congestion and enable two-way power flow. It will have the capability to encourage and enable users to shed load during peak power, thereby deferring the need to build additional infrastructure. The future grid will incorporate an open architecture approach, leverage existing internet protocols, encourage plug and play designs, employ common technology standards and be interoperable. According to the U.S. DOE incorporation of the following five types of technologies is essential to smart grid success 1) integrated communications for access to real-time information, sending time-of-use price signals, and control; 2) sensing and measurement technologies to support remote monitoring and demand side management; 3) advanced devices such as power electronics, energy storage, and superconductor; 4) advanced control approaches, and 5) improved user interfaces to simplify decision making for grid operators and consumers [6].

## **2.7 DISTRIBUTED ENERGY RESOURCES (DER)**

Distributed energy resources include demand response programs initiated by electric utilities, distributed generators that produce power locally, and energy storage systems. Combining distributed generators with energy storage, sensors, communications and load management software can yield an increased amount of energy savings and enable a backup supply, thereby improving the reliability and quality of power consumed by the user [23][24][25].

At residential, secondary distribution scale, a rooftop solar panel system combined with energy storage in the form of batteries has the potential to reduce a home's overall energy consumption and reduce its peak load. When this system is in communication with a home's smart meter, it can respond to electricity price signals sent by the utility and participate in demand response events.

### **2.7.1 Distributed Generation (DG)**

Distributed generators are power generating technologies that connect directly to the medium voltage and low-voltage sections of the electric grid and provide power near or at the load. They are normally installed by the end user to supplement their own power needs or provide backup power support in the event of an outage. DG can be of the conventional type, like reciprocating engines or gas turbines; electrochemical devices, such as a fuel cell; or based on renewable technology, such as wind and solar [23].

### **2.7.2 Demand Response (DR)**

Utilities can encourage end-use customers to reduce or shift their electricity use through demand response programs. These programs are also sometimes referred to as demand-side management and direct load control. Large scale DR becomes possible when the utility installs throughout its territory an advanced metering infrastructure with two-way communication capabilities built into a smart electric meter.

Price-based and incentive-based options offered by the utility are intended to alter electricity use patterns to shave peak load or shift electricity use to a time during the day where there is less demand. An involuntary demand response event can occur when the utility needs

to shed load to prevent a larger system failure or when demand exceeds available supply. A price-based program could include an energy price structure that varies depending on the time of day. Demand response events initiated by a utility that require users to reduce their energy use in exchange for lower bills are examples of incentive based DR programs. Reducing demand through DR programs helps the utility supply the system load without the need to build additional generation facilities [26][27].

### **2.7.3 Solar Energy**

Solar energy is a distributed energy resource that is rapidly growing in popularity due to incentive programs such as the California Solar Initiative [28]. Installation sizes vary widely depending on the application, from a few hundred watts to megawatts [23]. At the residential scale, an average installation ranges from 2-5 kW.

Photovoltaic (PV) cells harness energy from the sun by converting the sun's thermal energy into electric energy, namely electric current. Because PV cells rely on the sun to generate current, solar energy is considered a diurnal, intermittent resource that when interconnected with the grid requires that the utility absorb the intermittencies and act in effect as a large battery [29].

### **2.7.4 Energy Storage**

Intermittent resources such as wind and solar can be supplemented with energy storage by absorbing excess generation and supplying power when the sun does not shine or the wind does not blow. Storage can provide support during peak load and offset additional demand

required by plug-in electric vehicle charging [30]. Energy storage technologies include batteries, thermal, flywheels, and pumped hydro-energy storage.

The high energy density, lithium ion battery, is considered in this Thesis as a viable option to store excess power generation and then dispatch it when needed. These systems have the potential to level loads, provide backup power to critical devices, improve system stability, and offset generation capacity during times of high demand. Additional benefits include low noise during operation, no air emissions, zoning challenges or fueling needs [30].

## **2.8 PLUG-IN ELECTRIC VEHICLES**

Electric vehicles (EV) have continued to gain in popularity ever since their reintroduction into the general public in 2010 [31]. Using electricity for transportation reduces dependence on fossil fuels thereby increasing the nation's energy independence and reducing greenhouse emissions [6][18]. In 2007, the Pacific Northwest National Laboratory published a study that concluded if 73% of the nation's cars and small trucks were electric, existing U.S. power plants could meet their charging needs if they were recharged at night. This change in behavior could save 6.2 million barrels of oil per day [32].

However, large scale plug-in electric vehicle (PEV) charging presents a challenge to the existing electric infrastructure. The instantaneous power required to charge a single electric vehicle battery is roughly equivalent to adding another home to a secondary distribution circuit. Uncontrolled charging of many PEVs on a single secondary distribution transformer could overload the transformer and reduce its service life. Furthermore, general distribution circuit loading could occur if charging times are not controlled. The concept of using an electric vehicle's battery to provide ancillary grid support, known as vehicle-to-grid (V2G), complicates grid management further [18].

## **2.9 COMMUNICATIONS**

Historically, utilities are unaware there is an outage on their system until a customer contacts them to report it. As more customers report outages, the utility can better pinpoint the source of trouble. This results in a delay between the time the outage occurs and its repair. Installing sensors and communications technology will increase the utility's visibility of the system, help them to understand the scope of the outage situation, and ultimately reestablish service sooner. Distribution automation technologies and outage management systems that leverage automatic remote switching, smart meter information, wireless communications, and power line communication (PLC) systems have the potential to enable this much needed system awareness [15].

Use of communications systems, information technologies, and data management techniques in the distribution system and beyond enables the deployment of controls that can reduce system load when desired. The control system can respond to direct requests from the

utility to shed load, open or close remote switches to redirect power flow, and direct appliances to turn off or delay their start based on time-of-use or price signals. Electric vehicles can be asked to delay their charging process until the system load is reduced. Excess PV generation can be told to charge local energy storage systems. Energy storage systems, either utility owned or individually owned, can be dispatched to reduce peak demand or as needed.

## **2.10 ADVANCED METERING INFRASTRUCTURE (AMI)**

The advanced metering infrastructure includes the smart meter, communications hardware and software, and associated system and data management software required to record interval energy use and transmit changing price signals to the end user [33]. AMI makes the meter reader obsolete and helps to streamline the billing process.

Smart meters read bidirectional power flow and can receive dynamically changing price signals and energy use interval readings to the end user. With the AMI, net energy metering (NEM) and time of use (TOU) pricing programs become feasible. The AMI provides the infrastructure to allow the customer to see how the cost of their electricity use changes throughout the day and facilitates consumer engagement with distributed energy resources.

### **2.10.1 Net Energy Metering**

Net energy metering (NEM) programs provide incentives for customers to invest in distributed generation, such as solar. The program allows customers to offset their power demand from grid by generating power locally. When customers participate in a utility sponsored NEM program they are able to receive credits for power generated in excess of their demand. This special billing arrangement pays for the electricity at the full retail value. Credits are accumulated over a 12 month period. After the 12 month period, the customer can choose to receive payment for any excess power generated.

### **2.11 RESEARCH GAP**

An introduction to the huge effort associated with modernizing the United States electric power system is presented in the previous sections.

Efforts to modernize the power system are currently in their beginning stages. Funding released through the American Reinvestment and Recovery Act of 2009 helped to jumpstart research in system interactions of smart grid technologies as applied to the distribution system. And studies of how distributed energy resources and plug-in electric vehicles affect the secondary distribution circuit are currently ongoing. Copious amounts of data are being collected and will serve to validate research studies in the future.

Much research has been published on the effects of solar on the primary distribution circuit [17][34][35], but these studies do not include the effects of plug-in electric vehicles or consider impacts unique to the secondary distribution circuit. The effect of uncontrolled and controlled electric vehicle charging on secondary distribution circuits has been studied in



[36][37][38][38][39]. The potential to use energy storage to store excess solar generation along the secondary distribution circuit is just beginning to be considered [39]. This research seeks to fill a gap by studying the effect that high penetrations of rooftop solar, energy storage and electric vehicles have on secondary distribution circuit load profiles. The approach considered for this research is presented in the following section.

### **3 APPROACH**

The goals of this Thesis are to (1) establish the impact of introducing large amounts of distributed energy resources (DER) and plug-in electric vehicle (PEV) charging on the secondary distribution circuit and (2) identify smart grid management scenarios which can reduce consumer electricity costs and levelize residential load profiles using emerging smart grid technologies.

To achieve these goals, the following tasks are addressed:

#### **3.1 TASK 1: Characterize Key Stakeholders**

Key smart grid stakeholders affected by the installation of DER and PEV charging are characterized. Stakeholders considered herein include: consumers, environmental groups, utilities, regulators, policy makers, and technology developers/providers. Collaboration between these interested parties is critical to the success of the future smart grid.

#### **3.2 TASK 2: Categorize and Summarize Relevant Standards**

Federal and state policies and relevant standards important in guiding the roll out of smart grid technologies installed on the secondary distribution circuit are investigated. These policies will govern the eventual implementation, operation and deployment of the modern grid. Policy coordination along with a common set of technology standards will streamline the transition to a smart grid platform.

### **3.3 TASK 3: Develop Dynamic Model**

A quasi-steady state, time series model is created in MATLAB Simulink to simulate the effect of introducing varying levels of rooftop solar panels, lithium ion battery energy storage, plug-in electric vehicle charging, demand response events, and net energy metering on a secondary distribution circuit. Circuit simulations are based on the as built configurations of the homes upgraded to participate in the Irvine Smart Grid Demonstration illustrated in Figure 4.

Thirty-five homes, on 4 blocks are modeled. Each block contains a split-phase, 6930/240V, padmount transformer that supplies power to all the homes on that street.

The model of Block #1, the Zero Net Energy (ZNE) Block, represents a street of homes in which the total amount of energy used by each home, annually, is approximately equal to the amount of renewable energy generated on site. Nine homes are modeled; each with 3.6 kW DC rooftop solar, a 4kW/10kWh individual energy storage system and a Level 2 (240 V) electric vehicle supply equipment (EVSE). Each of the nine homes was issued a 2012 Scion iQ plug-in electric vehicle (PEV). The iQ has a 12 kWh battery that charges in approximately 3 hours at 240 V. The household load is aggregated and represents the time-resolved load as seen by the smart meter at the home's service entrance. Six of the 9 homes have air conditioning. The ZNE block employs a 50 kVA transformer.

Block #2, the Residential Energy Storage Unit (RESU) Block, is modeled with 8 homes connected in parallel to the transformer. On each of the six participating homes, approximately 3.2 kW DC solar is installed. Five of the six homes, with project installed rooftop solar, received the same 4kW/10kWh lithium ion energy storage system as Block #1. Four of the 8 homes have

air conditioning. Six of the 8 homes have received iQ PEVs. This block also contains a 50 kVA transformer.

Block #3, the Community Energy Storage (CES) Block, is also modeled as a street with 9 homes. Seven of the 9 homes are modeled with 3.45 kW DC rooftop solar and the same PEVs. Four of the 9 homes have air conditioning. One 50kW/100kWh shared battery is modeled on this street. This street has a 100 kVA transformer.

Block #4, the Control Block, is modeled to be essentially the same as Block #1 without the added distributed energy resources and electric vehicle charging capabilities. This block hosts a 75 kVA transformer.

An overview of the various technologies installed on each block is summarized in Table 1.

**Table 1. Summary of technologies modeled on each block**

<b>Block #</b>	<b>Name</b>	<b>Homes</b>	<b>Solar Installations</b>	<b>Air Conditioning Systems</b>	<b>Energy Storage Systems</b>	<b>Plug-in Electric Vehicles</b>
<b>1</b>	ZNE	9	9	6	9	9
<b>2</b>	RESU	8	6	4	5	6
<b>3</b>	CES	9	7	4	1	7
<b>4</b>	Control	9	0	6	0	0

### **3.4 TASK 4: Obtain Dynamic Load and Generator Data**

Measure and collect dynamic residential plug load and plug-in electric vehicle (PEV) charging power data representative of a typical southern California single family residence for use in the evaluation and analysis of the computer models developed for Objective 3. Three second resolution data were collected for multiple household loads and electric vehicle

charging events over a 30 day period. Voltage, current, real and reactive power measurements are collected whenever possible. Existing solar power generation data sets from locations in Irvine, not associated with this project, are leveraged and included as part of the load studies.

### **3.5 TASK 5: Analyze “Smart” Secondary Circuit Power Management**

#### **Scenarios**

Identify and apply dynamic secondary distribution circuit load profile management scenarios using models developed in Task 3 and data described in Task 4. Heuristic control strategies are applied to simulate load profile scenarios which utilize solar power generation, battery charging and discharging approaches, and electric vehicle charging events. Individual and community energy storage charge and discharge scenarios are considered.

## **4 TASK 1 RESULTS: KEY STAKEHOLDERS**

The smart grid is a complex system of systems, requiring cooperation between diverse communities of stakeholders. Millions of electric power customers rely on electric power system devices and interrelated systems developed by hundreds of thousands of suppliers and operated by thousands of utilities. Smart grid stakeholders; consumers, environmental groups, utilities, regulators, policy makers, and technology providers will must work together to create a reliable, efficient and secure grid.

### **4.1 CONSUMERS**

Electricity users will play an actively role in the successful rollout of the smart grid now and in the future. Consumers will interface with the smart grid through an advanced metering infrastructure (AMI) which consists mainly of a two-way communications backbone and smart meters. Smart meters reading bidirectional power flow and can receive and transmit dynamically changing price signals and energy use interval readings to the end user.

AMI allows the customer to see how the cost of their electricity use changes throughout the day and facilitates consumer engagement with distributed energy resources. Monetary incentives can be employed to encourage consumers to cut energy use during peak demand times and shift their energy use to lower periods of demand. Consumers can actively manage their electricity costs through demand response program participation, installing energy efficient devices, generating and storing power locally or by signing up to participate in net metering programs.

Significant consumer education and outreach will be required as the smart grid evolves. Actively engaging consumers to participate in conserving energy will not only reduce their electricity bills, but offset the need to build additional power plants. Early attempts to encourage consumer involvement in demand response programs have shown 10% reductions in electricity bills [41].

## **4.2 ENVIRONMENTAL GROUPS**

Environmental protection interest groups will be very interested to know that the evolution towards a smarter grid provides a once in a lifetime opportunity to build environmental and energy sustainability into the electricity grid. Utilizing smart meters and distributed energy resources; such as solar, energy storage and demand response programs, will encourage energy conservation and contribute to reducing our nation's ever increasing carbon footprint. Distribution systems outfitted with smart grid enabled technologies can reduce carbon dioxide emissions by up to 25% [42].

Peak load shifting through demand response initiatives can offset the need to fire up high emission peaking power plants. Leveraging low-load times of day to charge increasing numbers of plug-in electric vehicles will offset the need to build additional generation and could reduce CO<sub>2</sub> emissions if the electricity mix used to charge the battery comes from clean generation sources, such as nuclear and solar [43]. Additionally, capitalizing on previously idle capacity during low demand hours could reduce off-peak rates.

### **4.3 UTILITIES**

Electric utilities will benefit in numerous ways by progressively adding smart grid capabilities to the electric power system. Modernization will help utilities incorporate sensing, communications, and control technologies to operate existing generation, transmission, and distribution assets more efficiently, reliably and with improved load factors. Modernization will introduce high penetrations of distributed energy resources closer to the end user thereby reducing electrical losses. Modernization will reduce system wide greenhouse gas emissions by providing energy conversion efficiency improvements. Modernization will deliver higher power quality to increasing amounts of electronic devices. Modernization will help the grid to be impervious to natural disasters and man-made threats.

Migrating to a smarter grid requires a systems design approach similar to those found in other complex technological businesses such as the software development industry, automotive industry, and the like. The U.S. DOE has worked to develop a roadmap called the Smart Grid Maturity Model to help utilities and other stakeholders create a plan for success as well as communicate their strategy and vision [3].



## 4.4 REGULATORS

Regulators operate according to the Regulatory Compact, which recognizes the electric utility as a natural monopoly that has an obligation to minimize the cost of electricity to its customers. The Regulatory Compact requires that the utility maintains a financially sound business, minimizes future costs and balances environmental and social concerns. In return, the utility has a right to earn a fair return on its investment [44]. The traditional approach to regulate the electric utility industry, known as cost-of-service regulation, will undergo significant restructuring to enable grid modernization.

The smart grid interoperability framework and roadmap devolved by National Institute of Standards and Technology (NIST) (see Section 5.2) will guide regulators while they develop regulations that will benefit both utility business objectives and their need to make modernization investments while simultaneously protecting the consumer from excessive electric rates. Concurrently, state regulators have adopted renewable portfolio standards to meet state targets for meeting renewable energy generation requirements, imposed limits on greenhouse gas emissions and adopted policies that enable utility scale smart meter installations thereby enabling large scale demand response [45].

The effect that these competing goals will have on future rate structures will emerge over time. The transition to a smarter grid will likely require additional regulations be adopted by both the Federal Energy Regulatory Commission (FERC) and the National Association of Regulatory Commissions (NARUC). Increased coordination among federal, state, and local regulators and policymakers will be required for a successful smart grid role out.

The U.S. DOE has created a FERC/NARUC Smart Grid Collaborative to consolidate the myriad of smart grid issues, technologies, best practices, and lessons learned. Through the collaborative, Regulators can review all publicly available smart grid related documentation and interact with various subject matter experts to help make informed ratemaking decisions [45]. These documents are made available to all smart grid stakeholders through the Smart Grid Clearinghouse website [46].

#### **4.5 POLICY MAKERS**

As described in Sections 2.4 and 2.5 of this Thesis, the U.S. Government, through the auspices of the Department of Energy (DOE), has taken an active role in realizing the future electricity grid. Policy Makers are accountable for ensuring the Nation's continued growth and security of its greatest technological achievement. Government officials are responsible for ensuring that national energy policy provides rules for address grid security issues both from natural disasters and physical and cyber-attacks. One way policy makers aim to secure the grid is by enacting policies aimed at reducing the U.S.'s dependence on foreign oil.

Like regulators, policy makers must balance competing priorities such as keeping the cost of electricity down while investing in smart grid infrastructure, ensuring grid security, and stimulating economic growth through energy related job creation. Information shared through the Smart Grid Collaborative (Section 0) will guide policy makers, at all levels of government, to make informed decisions during the legislation development process.

State governments have adopted renewable portfolio standards requiring specific amounts of its states' energy mix to come from renewable sources (Section 5.3). At the federal level, Cap and Trade environmental policy mandates limits on emissions, creates emissions allowances, and allows flexibility with how emitters comply.

## **4.6 TECHNOLOGY PROVIDERS**

Realizing smart grid requires research, development, design and marketing of a myriad of new products of services. The Electric Power Research Institute (EPRI) and Pacific Northwest National Laboratory estimate that over the next 10-15 years the smart grid market will reach \$200 billion [47]. Development of future technologies and energy services is required for the transition to a smarter grid.

Thus, smart grid will encourage existing and new businesses to participate in the development of new load management strategies, distributed generation technologies, energy storage and demand response capabilities. Smart grid technologies made possible by advancements in the telecommunications industry will allow system operators to better visualize the system and respond to outages. Smart sensors, controls, industry accepted communications protocols (Section 5), tools for system planning and operation, and advanced components will all help to make the grid more reliable and efficient.

## **5 TASK 2 RESULTS: RELATED LAWS AND RELEVANT STANDARDS**

State and Federal energy policies will influence how the smart grid evolves over time. Likewise, a coordinated set of standards developed for the purposes of transitioning to a smarter grid will influence the smart grid development path. This next section describes the standards and polices most relevant to this Thesis.

### **5.1 IMPORTANCE OF STANDARDS**

Standardizing important characteristics of products, services, and systems enables interoperability, simplifies product development, highlights best practices and streamlines product creation to market. They are a key component of products' and services' market success. Standards [48] are normally developed using an open, consensus process that solicits input from many stakeholders such as utility representatives, system operators, regulators, engineers, and consumers. Completed works aim to be both vendor/technology neutral and scalable. Integrating products and services into a complex system, such as the electric power system, requires cooperation amongst all the interested parties and this collaboration can be vetted in advance through the standard development process.

Today's grid is undergoing a profound and fundamental change in the way it operates and developing standards for the interconnection, commissioning, operation of new technologies and services will help the gradual transition to a smart grid occur while the grid continues to run safely, reliably, and efficiently.

## **5.2 NATIONAL INSTITUTE OF STANDARDS AND TECHNOLOGY**

The National Institute of Standards and Technology (NIST), a non-regulatory agency of the United States Department of Commerce leads the effort to identify and evaluate existing standards for grid interoperability, communications, measurement techniques, services, and technologies to streamline the modernization of the smart grid [6]. NIST works with the major standards organizations, such as the GridWise Architecture Council, International Electrotechnical Commission (IEC), Electric Power Research Institute (EPRI), American National Standards Institute (ANSI), and the Institute of Electrical and Electronic Engineers (IEEE) to revise and create the protocols, standards, and a self-sustaining development process that supports the evolution of the Smart Grid. The agency is responsible for preparing reports to Congress which highlight standards areas requiring improvement and additional work.

NIST is mandated by the Energy Independence Act of 2007 (EISA) to report on its standards coordination efforts. Thus far, NIST has released an interoperability framework and roadmap[16] that recognizes 31 high priority standards and 46 others requiring industry input. The framework also identified a set of 19 “Priority Action Plans” that aim to tackle important gaps in the standards. The goal of the framework is to provide stakeholders with a shared understanding of the elements of the Smart Grid their relationships, and provide a pathway to integrate the various systems.

## **5.3 CALIFORNIA’S RENEWABLE PORTFOLIO STANDARD**

California’s Renewables Portfolio Standard (RPS) requires electricity providers procure 33% of their energy needs from renewable energy resources by 2020 [49]. It is considered to be the

United States' most ambitious renewable energy standard. The law was originally established under Senate Bill 1078 in 2002, then accelerated and expanded by Senate Bills 107 and X1-2, respectively [50]. Utilities are allowed included excess generation from net energy metering (NEM) participants as part of their RPS procurement accounting. Including renewable generation from NEM also helps to satisfy the law's requirement that at least 50% of the renewable generation come from within California [51][49].

#### **5.4 CALIFORNIA STATE POLICY OF NET ENERGY METERING**

In 1996, California state government enacted California Statute, Public Utilities Code (PUC) Section 2827, which requires the California Public Utilities Commission (CPUC) to regulate a net energy metering (NEM) program and provide compensation to ratepayers for surplus renewable distributed generation [51]. The goal of this statute is stimulate private investment in renewable energy resources, encourage economic growth, reduce demand (especially during periods of peak energy use), defer investment in electric power system infrastructure, meet Renewable Portfolio Standard (RPS) goals, and encourage electricity users to take an active role in conserving energy and using energy resources more efficiently.

Program participants are allowed to install, interconnect to in parallel with the grid, up to 1 Megawatt of renewable energy generation (such as wind, solar, biogas, or fuel cell) to serve some or all of their electricity needs. The DG installed by the NEM customer is required to meet all safety and performance standards required by law. An electric meter capable of measuring power flow in two directions is mandatory to determine the difference between the power generated locally and power provided by the grid. Net energy metering contracts will be

available on a first come, first serve basis until the total of all ratepayer owned distribute generators surpasses five percent of the utility's combined peak demand. In addition, standardized payment contracts and interconnection agreements between the utility and net energy customer are required [51].

The local ratemaking authority is required to offer a per kilowatt-hour (kWh) energy rate in the form of a monthly credit, to offset the cost of future energy use, or after a 12 month period the NEM participant can apply for monetary compensation of existing credits. Excess generation is paid using the same retail rate structure in place by the utility to charge for energy consumption. No additional fees; such as stand by charges, interconnection charges or monthly fees, outside of the existing tariffs paid by utility customers may be charged [51].

Ratemaking authorities are required to develop a new net generation energy rate to compensate its customer-generators for the value of the power generated, its renewable attributes, distribution asset use, and existing bond-related costs. The new rate will be decided by the CPUC after it is vetted through the ratemaking proceedings process. Once the compensation rates are established, the utility is allowed to apply these payments towards its annual RPS procurement goal or any future renewable energy credit [51].

#### **5.4.1 Net Energy Metering Implications**

It is important to note that the implications of implementing California Code, PUC Section 2827, may unintentionally burden low income electricity customers [51]. Today, home owners with the financial means to install renewable self-generation in their home, in order to offset their own energy costs, will ultimately purchase less energy from the electric utility and



therefore contribute less money to the infrastructure and generation portion of the energy rate. This could result in placing the burden of these necessary costs on the customers who do not have the means to own property and install distributed generation. When less energy is purchased from the utility, there is less money available to cover the cost of electricity associated with system wide maintenance, repair, and demand growth infrastructure projects.

Evaluation of the costs/benefits will be complex and the need to consider the environmental, public health, and societal benefits experienced in addition to monetary costs incurred by deploying more renewable energy resources is not considered in this Thesis.

## **5.5 ELECTRIC RULE 21**

Electric Rule 21 is a set of regulations that specifies how privately owned distributed generation should be connected, operated and metered by a publicly owned utility [52]. It is regulated by the California Public Utilities Commission (CPUC); a state agency created to regulate privately owned utilities such as electric, natural gas, and water. Although, each of California's three large investor owned utilities (Pacific Gas & Electric, San Diego Gas & Electric Company and Southern California Edison) has its own Rule 21 tariff, they contain essentially the same requirements. Their requirements, for each, are aligned with technical standard series IEEE Std. 1547-2003, "Standard for Interconnecting Distributed Resources with Electric Power Systems."

The rule applies to customers, connected to the electric power system (EPS), who generate their own power for all or some of their needs and for those generators built to sell electricity back to the grid through Public Utility Regulatory Policy Act (PURPA) Power Purchase Agreements (PPA) while connected to the provider's distribution or transmission system. Net energy metering programs required by PUC Section 2827 are defined within Electric Rule 21.

Rule 21 describes a process established by the utility outlining the steps required to connect a distributed generator to the grid. The tariff describes application requirements, design reviews, interconnections costs, and project timelines. The process to interconnect a generator with the grid varies depending on whether a generator will consume all of the power generated; export all of the power generated, or a combination of the two.

A homeowner will typically want to generate power locally to provide for most of her needs, but will also need the flexibility to sell excess generation to the utility. In this situation, participation in a NEM program makes the most sense. Southern California Edison's Smart Connect Program, a territory wide smart meter and communications backbone installation initiative, enables customer participation in a NEM program and satisfies PUC Section 2827.

## **5.6 IEEE Std. 1547-2003**

The Institute of Electrical and Electronics Engineers Standards Association (IEEE-SA) is a group within IEEE that has developed global, technology-neutral standards in a broad range of industries such as power and energy, information technology and communications for more than 100 years [53]. Proposed standards are developed through a collaborative process and voted upon by technical stakeholders for technical functionality and interoperability. Industry

standards help to advance technological innovation, allow complex system design, and enable interoperability between products.

One example of a set of standards published by IEEE-SA is the standard series IEEE Std. 1547-2003, "Standard for Interconnecting Distributed Resources with Electric Power Systems" [54]. Its purpose is to provide uniform technical and functional requirements to interconnect and test all types of distributed energy resources (DER) connected in parallel with the electric power system (EPS). It details requirements applicable to the operation, performance, test procedures, safety considerations, and maintenance of the interconnection. Also included are requirements for responses to abnormal situations, power quality, islanding, commissioning, and periodic performance testing. This standard applies to all DER technologies which operate as a 60Hz source with a combined capacity of up to 10MVA at the point of common coupling (PCC). The standard emphasizes installations interconnected with typical distribution or secondary distribution systems and emphasizes radial circuit installations, but does not exclude secondary network distribution systems. It is written from the perspective of the utility and therefore is intended to be technology neutral. One of its main requirements stipulates that DER automatically disconnect from the EPS during a fault. For safety reasons, DER is not allowed to supply power locally when the area EPS is not in service.

The standard also does not allow DER to actively regulate voltage at its PCC. The utility is required to maintain voltages within +/- 5% of the nominal voltage at the PCC in accordance with ANSI C84.1-1995 Range A [55]. A range is given since voltage will decrease monotonically along the length of a feeder due to the impedance of the line. If DER were allowed to regulate voltage locally, it could cause the voltage to rise outside of the allowable range.

Voltage regulation performed by a nonutility asset could conflict with existing voltage regulation arrangements. By virtue of its position on the circuit, DER can affect the local system voltage. Flow of real power through a resistance will increase the system voltage locally. When DER supplies part or all of a load at its PCC; the impedance seen by the nearest transformer is considerably reduced, resulting in reduced line losses.

### **5.6.1 Recommended revisions to the standard**

Future revisions of the IEEE 1547 are expected to address the need to ensure local reliability and stability of the EPS by allowing DER systems to control the local voltage [18]. Permitting the system to actively regulate the voltage and “ride through” longer voltage dips can increase the amount of time the DER is generating and improve local reliability. Power factor control through reactive power support can also be used to maintain system voltage requirements. Inverter based DG, such as a rooftop PV system, can easily provide reactive power to the grid if needed. If allowed, voltage regulation and circuit protection schemes imposed by the utility will also need to be revised. Additional communications, sensing, and switching devices will undoubtedly be needed along the circuit.

Voltage dips normally occur when there is not enough generation to meet demand. When a dip in voltage happens, under the current standard [54], DER must disconnect within 2 seconds of detecting an out-of-range condition and within 0.1s for extreme dips. Multiple DERs (i.e. generators) disconnecting from the grid during a voltage dip could have the unintended consequence of causing the voltage to drop further. The new lower voltage could then cause more generators to trip, and ultimately trigger a cascading failure. One solution to this issue is to allow DER to ride through the voltage sag for up to 10 seconds. Another solution is to keep the DER interconnected and generating to supply reactive power as necessary to maintain voltage range limits.

Requirements dictating when a DER is allowed to return to the grid will need to be defined. Instability in the local EPS can also occur if many of the previously disconnected generators return to the grid simultaneously. A staggered approach to interconnection after the system recovers from instability should be developed.

## 5.7 UL1741

Electric Rule 21 will allow inverter based DERs certified by UL 1741 “Inverters, Converters, Controllers and Interconnection System Equipment for use with Distributed Energy Resource,” as described in [56], to interconnect in parallel with the EPS without the need to undergo additional product testing. Underwriters Laboratory (UL) is an independent safety certification and consulting company that promotes product safety through certification, validation, testing and inspection [57]. UL offers a collaborative process to develop safety standards and codes for a variety of products including those that use electricity. The United States Occupational Safety and Health Administration (OSHA) recognizes it as a Nationally Recognized Testing Laboratory with the authority to conduct product safety testing and certification to products.

The UL 1741 is product safety focused and contains requirements for a range of technical attributes such as construction; power quality characteristics; compatibility with the local EPS; and performance, manufacturing, and production tests. Recommended procedures to test an inverter’s performance under variety of abnormal conditions are detailed within the document. The tests are designed to ensure an inverter responds appropriately to abnormal conditions. Test procedures are intended to complement and be used together with the series of IEEE 1547 standards.

## **6 TASK 3 RESULTS: MODEL DEVELOPMENT**

Computer models developed to evaluate the effects that integrated solar PV, electric vehicle charging, and energy storage have on secondary distribution circuit load profile are described in this section.

### **6.1 MODEL OVERVIEW**

The model was developed using a MATLAB/Simulink programming environment. It generates quasi-steady state, load demand profiles for secondary distribution circuits with installed smart grid technologies. The system model is based on the measured electrical demand characteristics and the dispatch of an integrated set of smart technologies installed at the Irvine Smart Grid Demonstration Project [58][59]. Power flows are resolved into 5 minute intervals, providing a snapshot of the overall load profile shape when smart technologies are introduced.

The model begins at the low side of the secondary distribution transformers of the four ISGD streets. Homes on each street are electrically connected in parallel to a designated transformer. It is assumed that the high side of each transformer is connected to a stiff power source. Four streets, with varying levels of installed smart grid technologies are considered. The 4 streets are categorized as follows: (1) Zero Net Energy block, (2) Residential Energy Storage block, (3) Community Energy Storage block, and (4) the Control block. The computer models for each street have been constructed to simulate the dispatch of an integrated set of smart grid technologies whose performance characteristics are measured from real world secondary distribution circuits installed in Irvine, California.

The Zero Net Energy (ZNE) block represents a street of 9 homes that have been upgraded to operate as zero net energy homes. That is, they produce as much power on site as they consume on an annual basis. To help achieve ZNE status, home efficiency improvements such as LED lighting, wall insulation, low flow faucets, smart appliances connected to a home area network (HAN), and solar hot water heaters were installed. The improvements are assumed to lower the overall energy demand of the home and are therefore reflected in the load data provided by the homes' smart meters. For this reason, home efficiency improvements are not included in the model. In addition, these homes were given smart meters, 3-4 kW rooftop solar PV systems, 4kW/10kWh individual energy storage systems, Scion iQ electric vehicles, and Level 2 electric vehicle chargers.

The Residential Energy Storage Unit (RESU) block represents a street of 8 homes which have received smart meters, 4 kW rooftop solar PV systems, 4kW/10kWh individual energy storage systems, Scion iQ electric vehicles, and Level 2 electric vehicle chargers. RESUs are individually controlled and can be managed by the home owners or the utility.

The Community Energy Storage (CES) block represents a street of 9 homes which share a single 25kW/50kWh energy storage system that is installed next to this street's transformer. The CES is remotely controlled by the utility. Like the ZNE and RESU blocks, homes on this street received smart meters, 4 kW rooftop solar PV systems, Scion iQ electric vehicles, and Level 2 electric vehicle chargers.



The Control (Ctrl) block consists of 20 homes. Homeowners on this block received only smart meters. Demand profiles of these control homes will be used to compare against demand profiles of the blocks that received smart grid technologies in future work.

For the purposes of modeling, technologies have been separated into six main subsystems: house load, rooftop solar photovoltaic (PV) panels, residential energy storage unit (RESU), community energy storage (CES), electric vehicle charging/electric vehicle supply equipment (EVSE), and transformer. A high-level block diagram for the different types of homes found on each street is shown in Figure 5. To simplify the diagram, one home from each street type is shown. The number of homes per street ranges from 8-20 and the home subsystem model (including all the modeled technologies) is repeated along the length of the circuit for each home. These subsystems are described in the sections that follow.

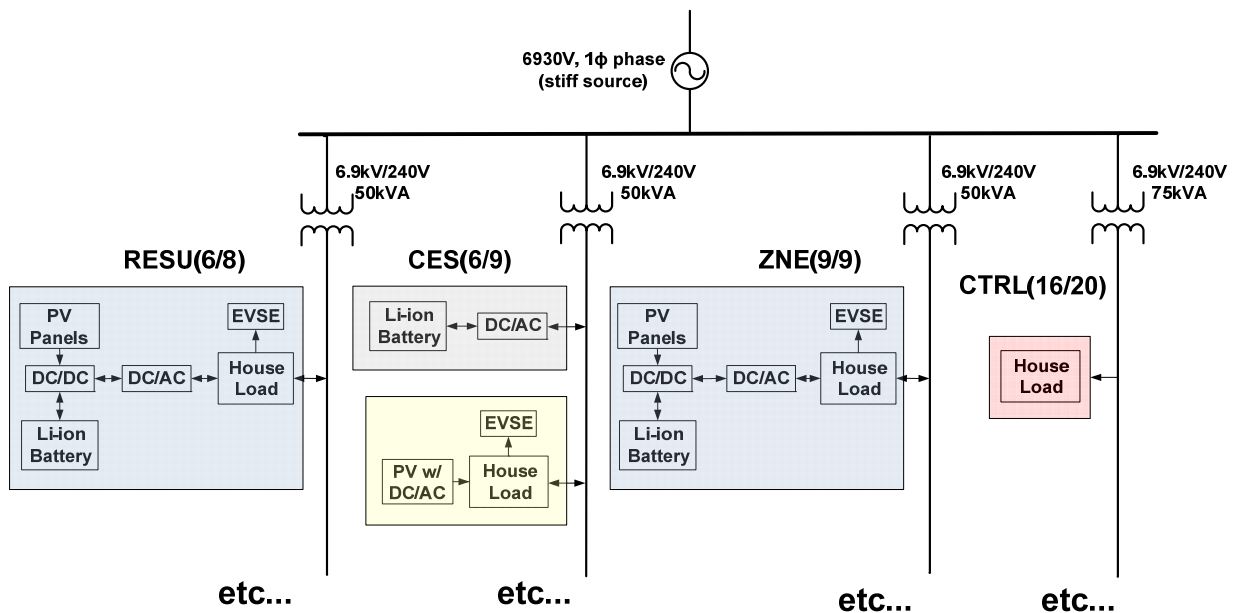

Figure 5. High level secondary distribution circuit model

## 6.2 SECONDARY DISTRIBUTION TRANSFORMER



Figure 6. Padmount, single-phase, three wire secondary distribution transformer with open cover to show measurement equipment

The model begins at the streets' secondary distribution system transformer and leverages MATLAB's SimPowerSystems component libraries to model the transformers installed on the ISGD circuits. A linear, three winding transformer model was chosen to simulate the transformers involved in the project. Secondary distribution transformers located on the ISGD streets are split-phase, pad mounted (to support underground electric service), oil filled, self-cooled and range from 50-100 kVA capacity. The transformers step down single-phase distribution voltage of 6.9kV to 240/120V.

The transformers considered for this project are outfitted with current transformers (CTs) and potential transformers (PTs) on the low voltage terminals to measure actual transformer voltage, current, real power and reactive power. The data collected with this measurement system can also be used in the model. A padmount transformer with installed measurement equipment is shown in Figure 6.

### 6.3 ROOFTOP SOLAR PHOTOVOLTAIC SYSTEM



Figure 7. Solar panels installed at a residence

The solar photovoltaic system modeled is based on the SunPower, E20-327 Panel. The 324 W panels contain 96 monocrystalline cells per panel and are assumed to be 20.4% efficient [60]. Figure 7 shows several of the panels installed on the roof of a participating residence.

Rooftop solar PV system models range in size from 3.2-3.6 kW AC. Variations in system size are based on the actual configuration of the panels installed on the ISGD streets. Depending on the configuration, 10-12 panels per system are modeled. The developed PV panel model is based on the standard mathematical equations used to describe the equivalent circuit of a photovoltaic cell as described in Gow and Manning. This model considers the typical equivalent circuit that includes a photocurrent source, diode, series resistor and shunt resistor [61].

The output of the nonlinear solar cell is affected by both temperature and solar radiation. An incremental conductance maximum power point tracking (MPPT) algorithm was developed to extract peak power from a solar cell [62][63]. At the 5-minute, quasi-steady state scale this step becomes unnecessary and the total losses associated with the MPPT, DC/DC converter, and DC/AC inverter contributions to the system can be assumed to be 3%. The model assumes

that together; the MPPT, DC/DC converter, and DC/AC inverter operate at 97% efficiency. A high level block diagram which shows the major components of the rooftop solar PV system is shown is illustrated in Figure 8.

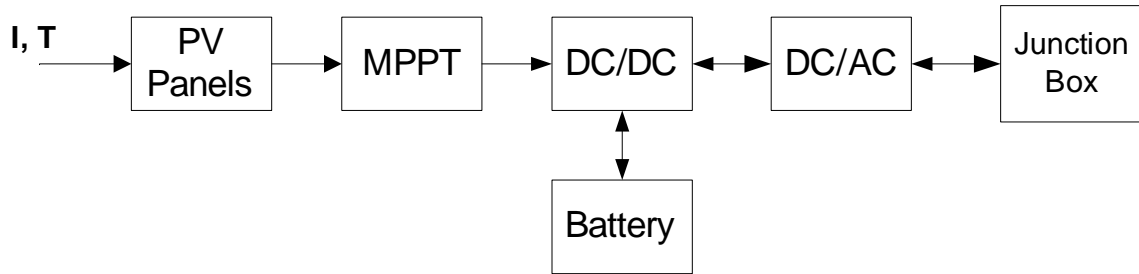

Figure 8. Residential rooftop solar PV system block diagram

Each PV model considers time varying irradiance in units of suns (G) and a fixed nominal temperature of 25°C to generate a daily profile of the power generated by each individual PV system. A high level block diagram of this model is illustrated in Figure 9.

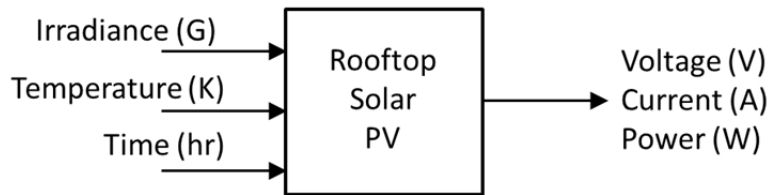

Figure 9. High level rooftop PV system diagram

## 6.4 ENERGY STORAGE

Energy storage can be used to store excess solar PV generation, reduce peak loads, and provide backup power during an outage. Computer models were created to predict the effect that these types of systems can have on the residential load profile.

### **6.4.1 Residential Energy Storage**

Residential energy storage units (RESUs) were installed at participating homes on the Zero Net Energy (ZNE) block and RESU block. The energy storage systems share an inverter with the rooftop PV system and are self-contained units that include 4kW/10kWh lithium ion batteries, a battery management system, and associated power electronics. The RESU can receive commands via a home area network or broadband connection. The RESU is designed to augment the power needs of residential homes and small businesses.

The RESU dispatch model is user configurable and considers the flow of charge power and discharge power during its 4 main modes of operation: utility control, time based control, price based control and demand response event response. The RESU model operates under the assumption that the system operates as designed and ignores physical characteristics of the system. It dispatches power and stores energy according to the mode of operation selected by the user.

During utility control, the utility can remotely configure and operate the RESU in any of the 3 other modes of operation. Control commands sent by the utility will override any commands set locally by the user.

When the RESU is set to time based control, the user can choose the time of day to charge and discharge the battery. Discharge power level is also user selectable and can be set at 2 kW or 4 kW. There is also an option to select a constant power discharge or load following discharge profile. The battery will discharge as scheduled until it reaches a user selected minimum state of charge.

Under the price based control mode of operation, the RESU will charge and dispatch based on the price signal it receives from the home's smart meter. The RESU will charge the battery when the cost of electricity is lowest, typically from 12:00AM-6:00AM and discharge when the cost of electricity is highest [64]. The charge/discharge cycle takes into account the RESU's roundtrip power conversion efficiency. A 25% difference in energy cost between on peak and off peak prices is required to yield energy savings.

When the RESU is set to accept demand response (DR) events from the utility, the RESU will discharge the battery to provide power until a minimum state of charge is reached. The RESU is not allowed to charge during the DR event. Demand response mode has the highest priority of all modes of operation and will override any other mode that is currently selected when the utility initiates a DR event.

#### **6.4.2 Community Energy Storage**

A Community Energy Storage (CES) system is installed on one of the blocks participating in the ISGD project. It is a 25kW/50kWh lithium ion battery energy storage system connected to a secondary distribution transformer that is controlled by the utility to provide auxiliary power. It is equipped with on board controls to manage charge and discharge events. The CES can provide load leveling, peak shaving, and backup power support to the local secondary distribution circuit. It is assumed to have 85% roundtrip power conversion efficiency. The CES computer model attempts to replicate the features deployed in the installed CES.

During backup power mode, the CES will cause a bypass switch to open thereby disconnecting the secondary distribution transformer from the circuit and enabling that part of

the circuit to operate as an island. The CES will discharge according to a load following strategy until its batteries reach a selected minimum state of charge. The unit will supply up to 50 kWh to the connected homes. In general, the CES is charged in the late evening/early morning hours when demand and electricity prices are low.

In the peak shaving mode, the CES is set to begin discharging at a specified time and discharge at a constant power until the battery reaches its minimum state of charge. The discharge start time and discharge power are controlled by the utility.

In load leveling mode, the utility sets a trigger demand level that causes the battery to discharge whenever the load is above the set level. The CES will dynamically discharge and supply power to the load in excess of the threshold level.

Both the peak shaving mode and load leveling mode can be employed in response to a specific demand response event or as part of the utility's daily demand reduction strategy.

The CES dispatch model operates under the assumption that the system operates as designed and ignores physical characteristics of the system. It dispatches power and stores energy according to the mode of operation selected by the user.

## **6.5 PLUG-IN ELECTRIC VEHICLE CHARGING**

Electric vehicle charging events were measured and recorded at both 3 second and 5 minute resolutions to provide the load profile seen by the grid during modeled scenarios. These data were used to model electric vehicle charging events during a daily load profile.

A description of how the data were collected can be found in the next section. Various measured charging events were overlaid onto the load profiles of participating ISGD homes in a random and uncontrolled fashion. Only uncontrolled (Level 2, 3.3 kW) charging events were considered in this research.

Charging events were randomized across the ZNE, CES and RESU blocks. Charging flags were assigned to each home and if that home was chosen by the random number generator then it had a charging event profile assigned to that home's daily load profile. Next a charge start time is randomly chosen from a set of times that homeowners are likely to charge their vehicles. It is assumed that homeowners are most likely to start charging sometime between the hours of 5:00-7:30PM, somewhat likely to charge in the morning from 6:00-8:30AM, and less likely to charge during the midday.

## **6.6 RESIDENTIAL LOAD**

The residential load model is based on data collected in a local home and smart meter data obtained from the participating ISGD homes. The demand profile is highly nonlinear and varies greatly from home to home and from day to day. To help organize trends seen in the data, model runs can be grouped according to seasons, weather, and days of week. As more data is collected throughout the data collection period of the ISGD project, it is likely that load demand profile categories can be refined further.



## 7 TASK 4 RESULTS: OBTAIN DYNAMIC LOAD AND GENERATOR DATA

### 7.1 TRANSFORMER DATA

Initial transformer load data acquired for this research was collected using a Dranetz Power Xplorer PX5 power monitoring instruments installed on the four Irvine Smart Grid Demonstration (ISGD) project transformers. Five minute interval load data from the 4 secondary distribution transformers were collected and converted from COMTRADE to .CSV files. Initial sets of data showed unexpected load patterns and deemed as corrupted data. Sample sets of data collected by the Dranetz meters are shown in Figure 11. It was later discovered that the batteries required to power the Rogowski coil current transformers (CT), seen in Figure 10, were unable to hold a charge for a significant length of time, causing the corrupted data.

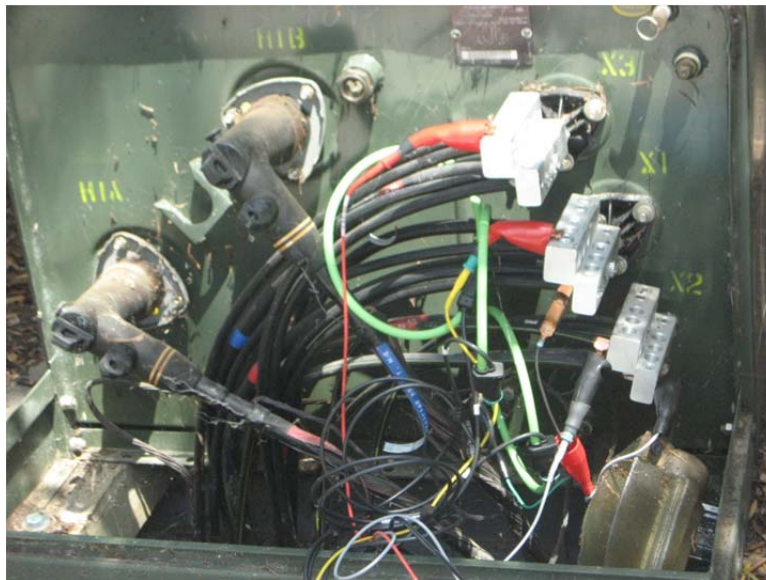

Figure 10. Rogowski coil CTs installed on a padmount, secondary distribution transformer

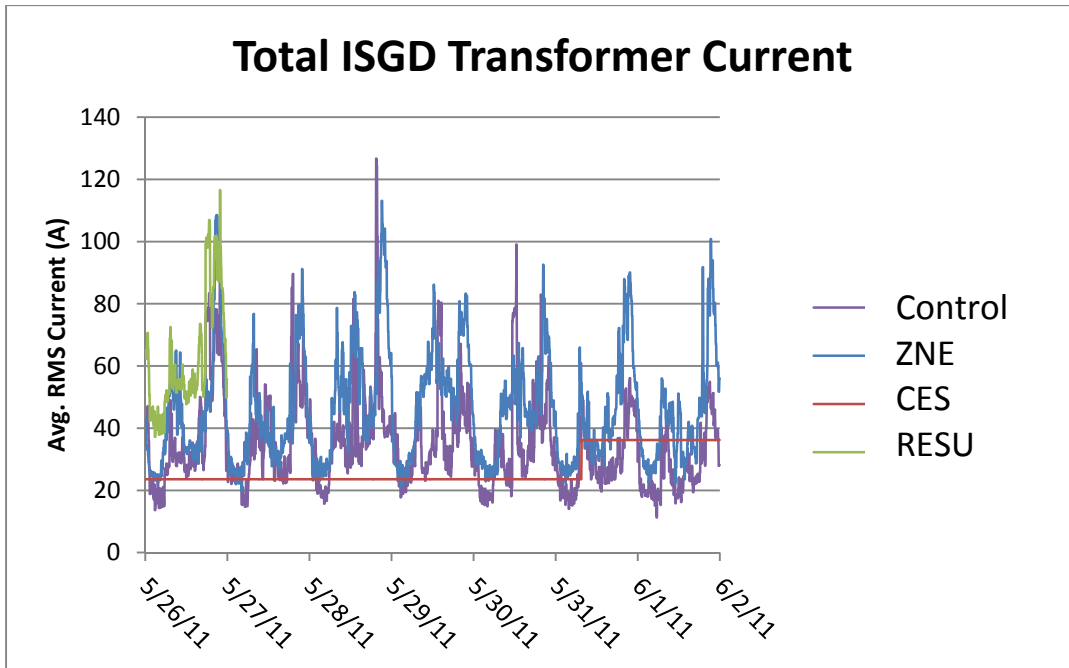

Figure 11. Initial ISGD transformer current measurements

As a long term data collection solution, On Ramp Wireless (ORW) was contracted to install a remote monitoring system that allows power data to be transmitted wirelessly, stored on a remote server and accessed via a web interface. On Ramp Wireless’s monitoring and control system uses a novel signal processing techniques that enables it to find weak signals in high noise environments thereby enabling nonintrusive, low-power consumption, and monitoring of smart grid technologies.

During analysis of the data collected using the ORW solution it was discovered that measured data signals are time stamped for when those data are transmitted as opposed to when they are collected. This technique causes two issues: 1) data are stored at irregular intervals and the number of data points will vary from day to day and 2) time stamps will not be consistent with GPS time stamped smart meter data installed in the homes. This technique

causes errors in the future comparisons of total transformer load with the sum of all the smart meters connected to that transformer.

Another issue discovered during data analysis was that split-phase RMS current measurements less than 7 amperes were stored as zero. Examples of this situation can be seen in Figure 12. The cause of the “7 amp issue” was due to the database’s ability to store variables only as integer values instead of floating point numbers. The GridSense Transformer IQ current transformer used in this system to measure current is capable of making these low current measurements, but the database was not able to store the values to the level of precision required by the project. A software fix was issued to the ORW system enabling the database to store an additional digit by multiplying the measured current by 10 and then reporting the calculated value. This increased the precision of the stored value by a factor of 10.

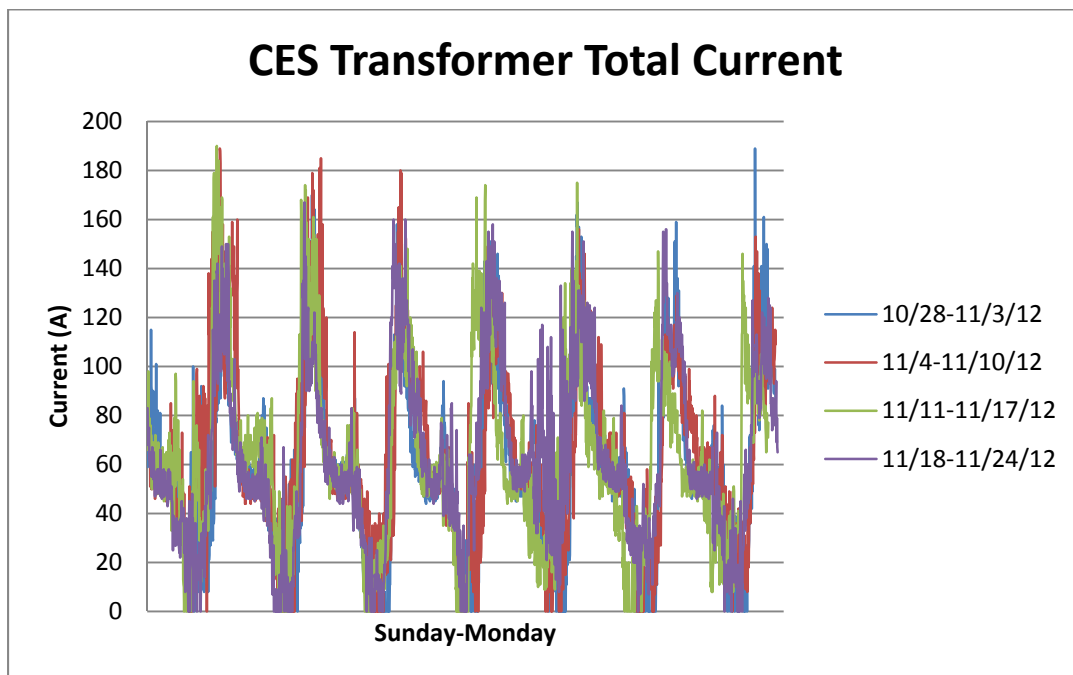

Figure 12. Measured, 5 minute resolution, daily, CES transformer load profiles

Analysis of this data uncovered a third issue. Direction of current flow, indicated by the current phase angle, was not included in the data set. It has been determined that it is possible to extract the current phase angle from the set of hex data reported by the CT. The phase angle will be included as part of a future ORW software release.

Direction of current flow is determined using the following guidelines: 1) Current is considered to be flowing in a positive direction when  $-90^\circ < \text{phase angle} < +90^\circ$ ; 2) Current is considered to be flowing in a negative direction when  $\text{phase angle} > 90^\circ$  or  $\text{phase angle} < -90^\circ$ . Positive current is taken as current flowing from the transformer to the homes.

## **7.2 RESIDENTIAL LOAD DATA**

DENT Instruments ELITEpro Recording Poly Phase Power Meters were used to measure RMS voltage, current, real power and reactive power measurements at 3 second intervals on the distribution panel and various locations within a residential home. The 1150 ft<sup>2</sup> home is located in southern California, fifteen miles south of the Irvine Smart Grid Demonstration (ISGD) project. The home was built in 1976, does not have air conditioning, and uses an electric range. Load data were collected at this location to fill a need for data before ISGD project data became available. Individual current transformers were installed at the service entrance, on each circuit breaker, and directly at the electrical outlets on important loads within the home. A representative sample of the loads measured is described in this section.

Figure 13 illustrates how the load can change within a home throughout the day over the course of a week. At any given time, on any given day, the load will vary dynamically. Figure 14 provides a glimpse of the dynamic nature of a residential load for a single day. Power quality

meters which can provide waveform level measurements, would show even a higher degree of load variability. The variable nature of loads, in general, is not a concern for the utility. The aggregate of multiple loads seen upstream is much smoother and can be seen at the secondary distribution transformer previously shown in Figure 12.

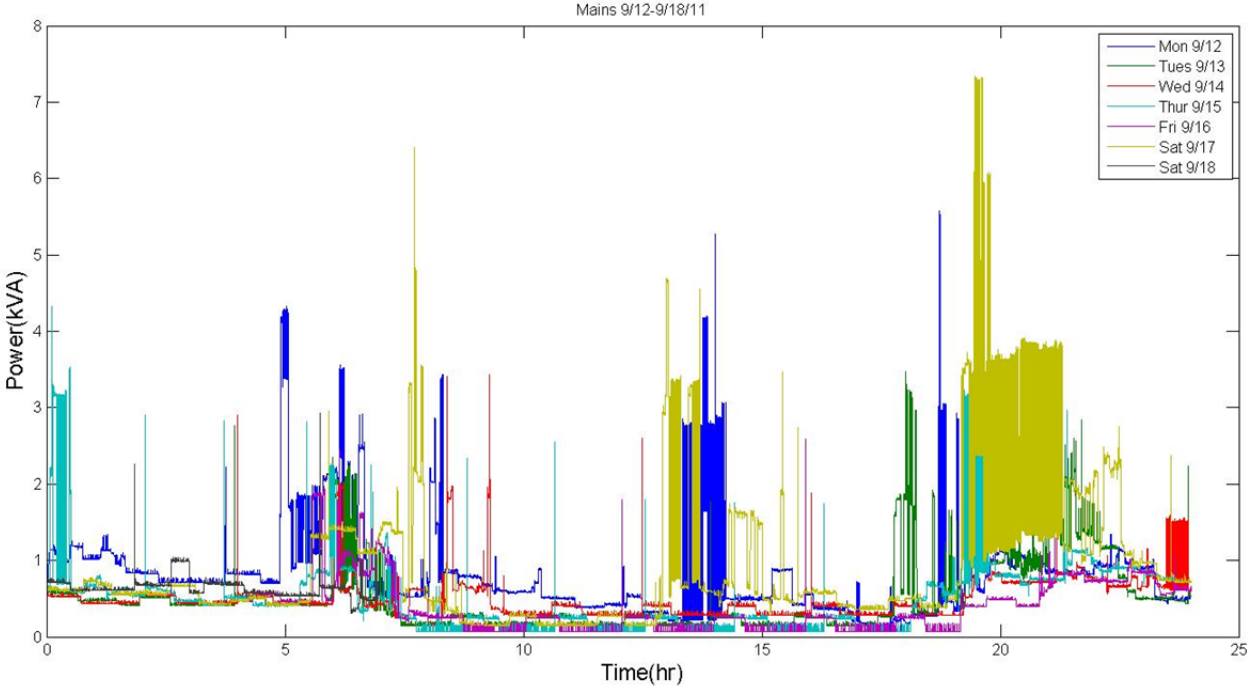

Figure 13. Measured, 3 second resolution, residential daily load profiles

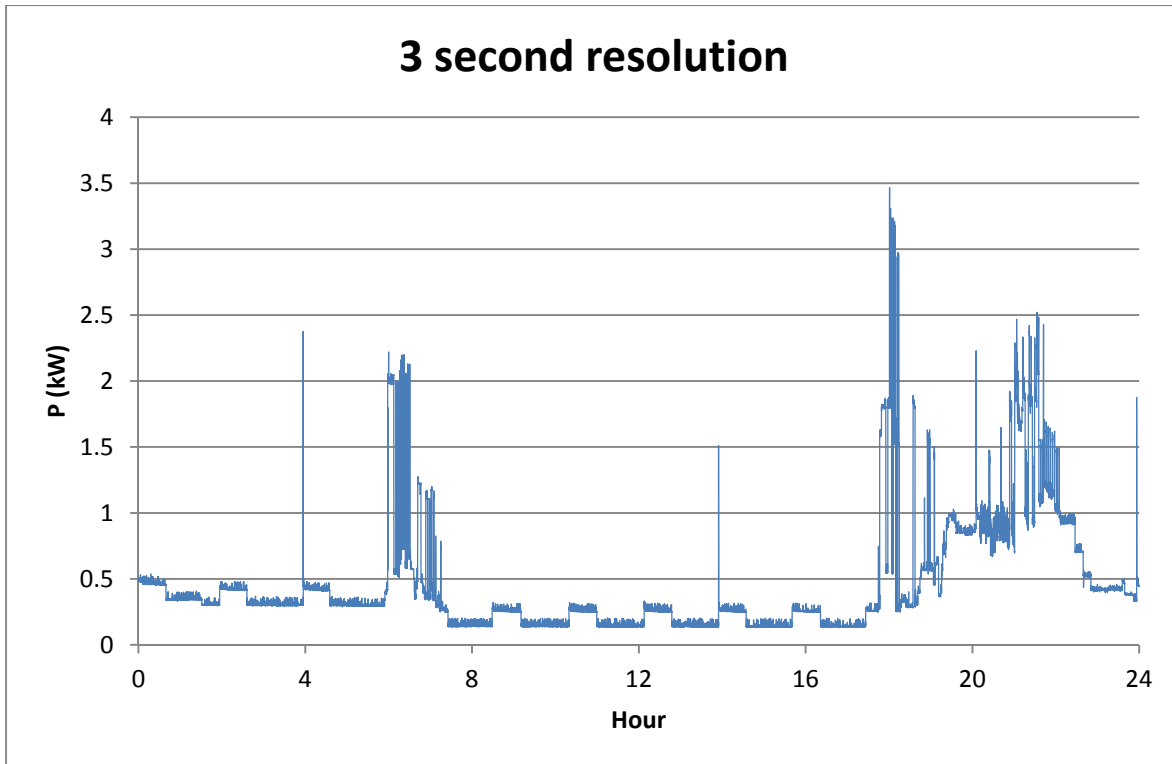

Figure 14. Measured, 3 second resolution, weekday, residential load profile

Table 2 summarizes the total energy consumed by the home each day. On average, this home consumed 13.2 kWh of energy per day. Nationally, the average daily energy consumption of a U.S. residential utility customer is 30.1 kWh [65].

Table 2. Summary of total energy consumed in home, per day, for 1 week

Day	Total Energy Used (kWh)
Mon. 9/12/2011	18.1
Tues. 9/13/2011	10.7
Wed. 9/14/2011	10.8
Thurs. 9/15/2011	10.2
Fri. 9/16/2011	9.1
Sat. 9/17/2011	19.0
Sun. 9/18/2011	14.3
<b>Average</b>	<b>13.2</b>

Figure 15 presents the measured, daily load profile of an energy star, 19.2 cubic feet, bottom-freezer refrigerator. Periodic spikes in power consumption indicate that starting of the refrigerator compressor.

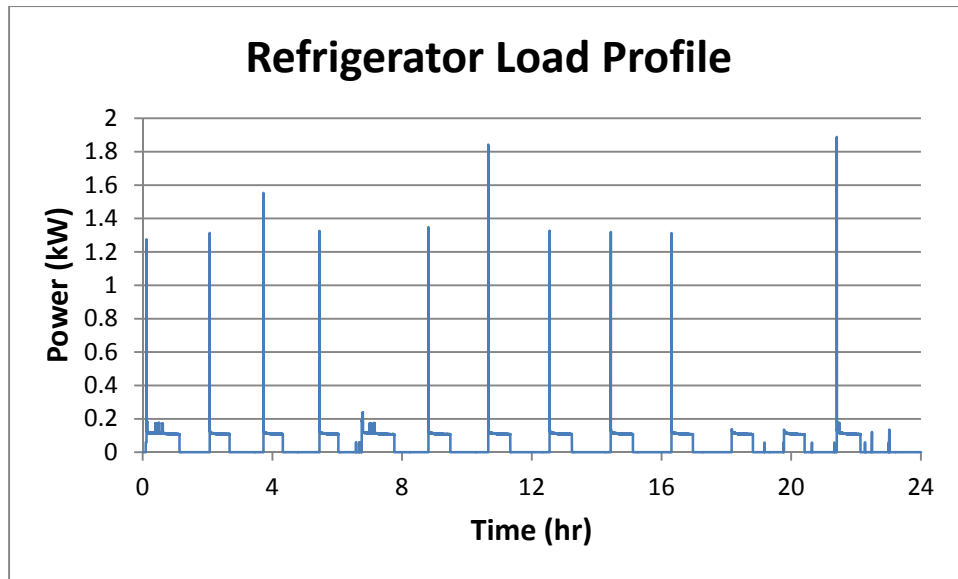

Figure 15. Measured, 3 second resolution, daily, refrigerator load profile

These 1.5 kW spikes can also be seen Figure 13 and Figure 14. Total energy used by the refrigerator over 5 days is shown in Table 3. The average daily energy used by the refrigerator was 1.2 kWh.

Table 3. Total energy consumed by refrigerator for 5 days

Day	Total Energy Used (kWh)
Tues. 9/6/11	0.94
Wed. 9/7/11	1.2
Thurs. 9/15/11	1.1
Fri. 9/16/11	0.95
Sat. 9/17/11	1.2
Sun. 9/18/11	1.7
Average	1.2

A power meter was also installed at the electrical outlet of the home's energy star, natural gas clothes dryer. Figure 16 demonstrates the measured power profile for a clothes drying event. A total of five separate drying events were recorded.

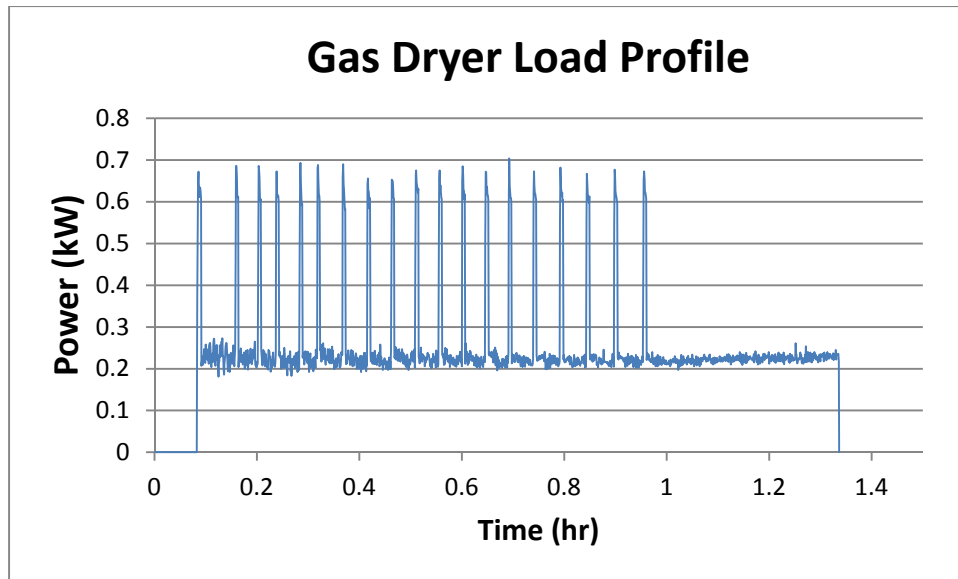

Figure 16. Measured, 3 second resolution, gas clothes dryer load profile

Table 4 summarizes the amount of energy used for 5 clothes drying events. Drying times range from 52 minutes to 2 hours, 25 minutes. The amount of energy required to dry a load of clothing varies accordingly. Clothes drying times vary depending on the size of the load, the amount of moisture present in the clothing, and the type of fabric being dried. A load of terry cloth towels will take much longer to dry than a load of children's clothing. The average energy used for the 5 drying events was 0.41 kWh.



Table 4. Total energy consumed for 5 separate clothes drying events

Drying Events	Length of Event (H:MM)	Total Energy Used (kWh)
Event 1	1:16	0.33
Event 2	2:25	0.78
Event 3	0:52	0.25
Event 4	1:37	0.46
Event 5	0:57	0.23
Average		0.41

The drying events described above were preceded by the appropriate clothes washing events. Due to power meter wiring issues, only 3 of the 5 related washing events were captured by the power meters. Figure 17 illustrates the load profile of an energy star, front loading, high efficiency clothes washing event.

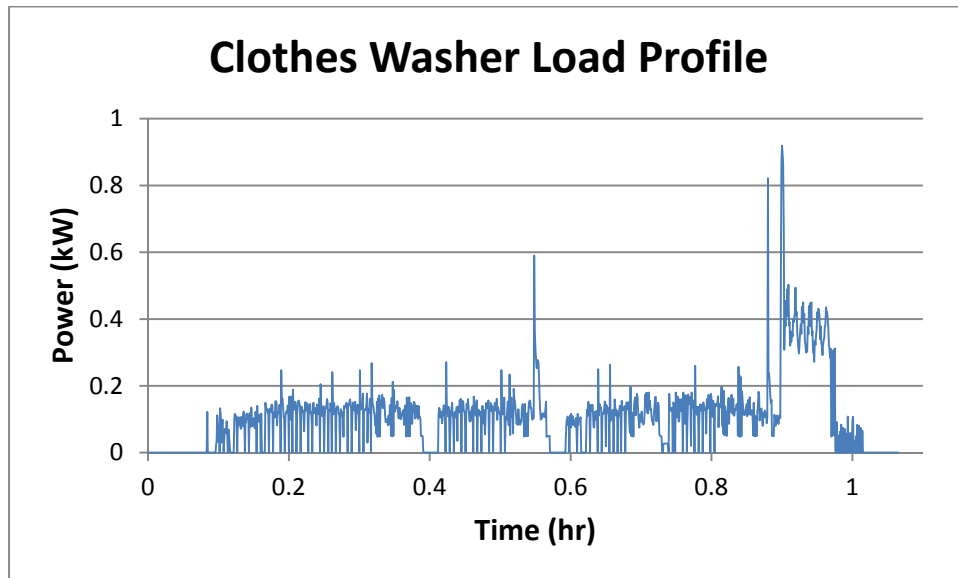

Figure 17. Measured, 3 second resolution, clothes washer load profile

Table 5 summarizes the amount of energy used and the length of time required for the 3 measured clothes washing events. The average amount energy used to wash the clothes was 0.11 kWh.

Table 5. Total energy consumed for 3 separate clothes washing events

<b>Clothes Washing Event</b>	<b>Length of Event (H:MM)</b>	<b>Total Energy Used (kWh)</b>
<b>Event 1</b>	0:56	0.12
<b>Event 2</b>	0:51	0.08
<b>Event 3</b>	0:54	0.13
	Average	0.11

### 7.3 SOLAR

Measured solar power generation considered for this research comes from a dual-axis tracking, concentrated photovoltaic (PV) panel scaled to represent a 4 kW, fixed panel system typically found in a residential setting. These data were chosen as a place holder for the measured ISGD project data. Unfortunately, measured PV data for the rooftop solar panel systems installed at the participating homes were not available in time for this research.

The data used herein will vary slightly from a residential PV system in that the dual-axis solar panel tracks the sun throughout the day yielding higher power outputs than the typical fixed panel configuration. However, this data set provides a 1 minute data resolution that illustrates the effect of PV output on cloud cover more clearly than the 5 minute resolution ISGD project data can. Figure 18 illustrates solar power produced for a sunny day with little cloud cover. Periods of light cloud cover throughout the day will decrease the PV power output for short intervals of time. Only on the occasion when there are no clouds in the sky will there be the potential for a totally smooth PV output curve. During periods of cloud cover, PV output drops almost instantaneously to zero. Five minute, averaged interval data mask this transient behavior.

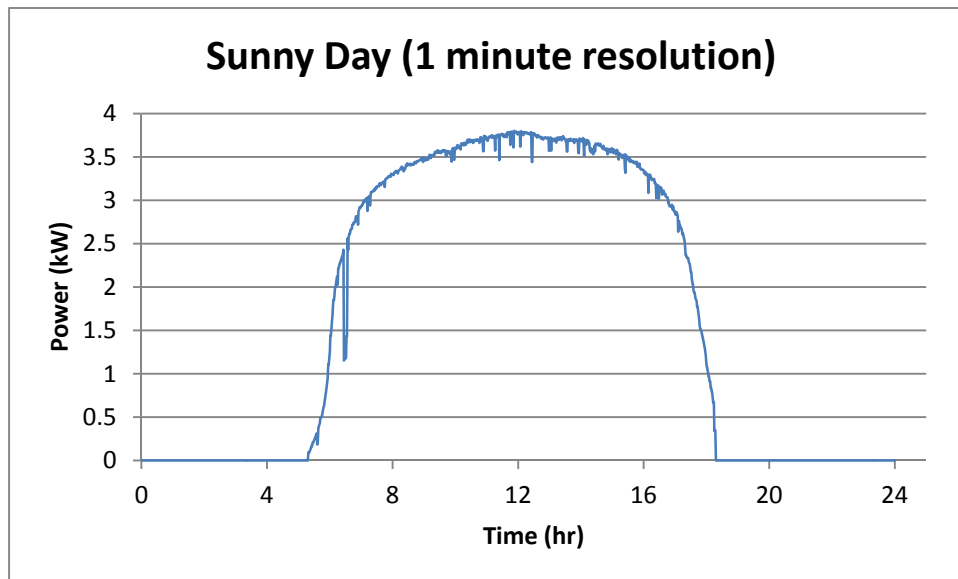

Figure 18. PV profile for a sunny day, 1 minute resolution

On a mostly cloudy day, rapid changes in power production can still be seen, but the magnitude of the change is diluted. Examples of how transients are lost when larger time steps are considered can be seen in the figures that follow. Figure 18 shows that on a sunny day,

there can still be some cloud cover thereby decreasing the PV power output for short intervals of time. Only on the occasion when there are no clouds in the sky will there be the potential for a totally smooth PV output curve. When calculating power flows at a 5 minute granularity on a sunny day, it is valid to assume that the PV profile for that day is smooth.

However, on a cloudy day, intermittent power produced by the PV panels paint a very different picture. Figure 19 displays measured PV real power output for a cloudy day over a 24 hour period at a 1 minute resolution. When we average the data over 5 minute intervals, some of the intermittency is lost. If the end goal is to understand how power flows on the circuit at 5 minute intervals, then transients that occur within the 5 minute interval are less important. However, we cannot expect to model or understand what is occurring on the circuit within these time scales, i.e. at higher resolutions, without taking into consideration the variable nature of this resource.

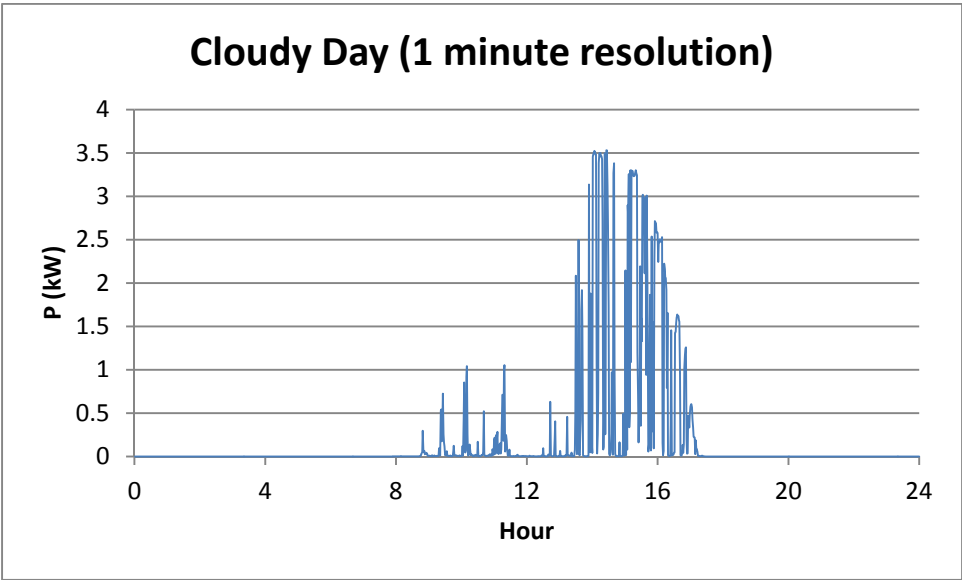

Figure 19. PV profile for a cloudy day, 1 minute resolution

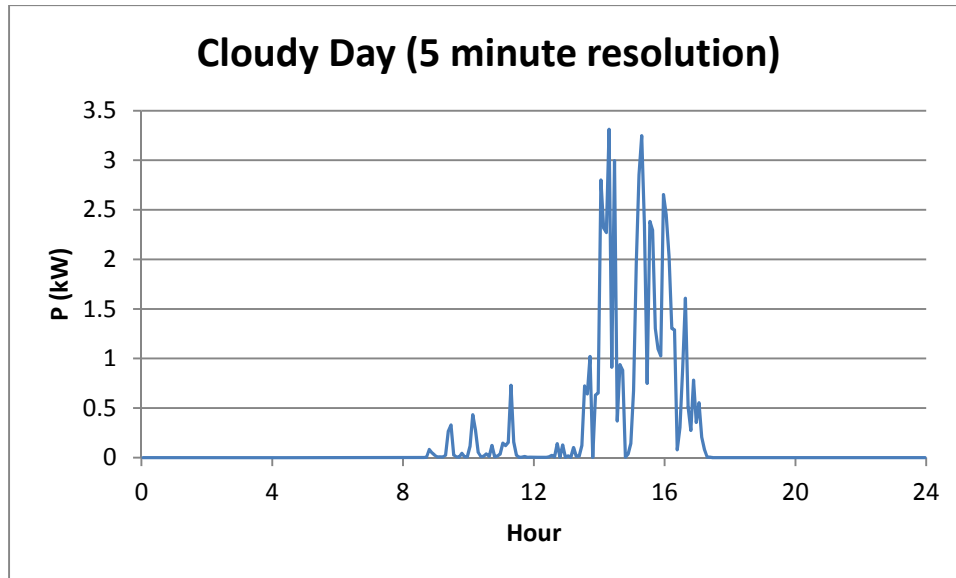

Figure 20. PV profile for a cloudy day, 5 minute resolution

#### 7.4 EV CHARGING ON CAMPUS & AT HOME

The DENT Instruments ELITEpro Recording Poly Phase Power Meter was used to measure voltage, current, real power and reactive power measurements at 3 second intervals for various plug-in electric vehicle (PEV) charging events. A representative sample of the charging behavior measured is described below. All measurements were made using a 20 A clamp-on current transformer (CT) at a standard 15 A NEMA electrical outlet. PEV charging of this type is known as Level 1 charging. Level 2 charging electric vehicle supply equipment was not available for testing during this research.

Society of Automotive Engineers standard, SAE J1772 [66], is the standard which defines a common PEV charging connector. J1772 defines the physical, electrical, communications and performance requirements for PEVs. A summary of Alternating Current (AC) PEV charging levels is provided in Table 6 [67]. Level 1 charging can be performed at any standard NEMA outlet; whereas Level 2 charging requires electric vehicle supply equipment that must be installed by a

licensed electrician. Level 2 charging takes place in roughly half the time it takes to charge at Level 1. Figure 21 shows the five-pin charge coupler defined in the J1772 standard and Figure 22 demonstrates the coupler in use.

Table 6. Standard PEV charging levels

Charging Type	Voltage	Current	Power
AC Level 1	120 V AC	15 or 20 A NEMA outlet	1.4 or 1.9 kW
AC Level 2	208-240 V AC	Up to 80 A	Up to 19 kW



Figure 21. SAE J1772 PEV conductive charge coupler



Figure 22. PEV charging coupler in use

Figure 23 presents two separate charging events measured during the charging of a 2010 prototype Toyota Plug-in Prius Hybrid Electric Vehicle (PHEV). Figure 24 shows a zoomed in view of the first charging event. The Prius PHEV features a larger lithium-ion battery pack than the standard Prius which allows up to 13 miles of all electric range. The mid-size PHEV has a 4.4 kWh battery that can be charged in approximately 3 hours at Level 1.

The 14 October, 2011 charging event (shown in both Figure 23 and Figure 24) illustrates a discrete charging event in which the vehicle is recharged from zero available all-electric miles to a fully charged battery. The battery is recharged in 2 hours, 54 minutes. The 17 October, 2011 charging event, shown in Figure 23, occurs over a 24 hour period in which charging begins on the previous day and the charging coupler is not unplugged until after 20:00. The vehicle is then driven until the electric range is fully depleted. It is plugged in again around 20:30. This second plot establishes that if the vehicle is left plugged in after charging is completed, the on-board battery charger will check the battery state of charge periodically and recharge the battery if necessary. For all charging events the battery charger stops charging periodically and checks in on the state of the battery. Battery cell temperature and battery state of charge are monitored throughout the charging event to ensure a long battery life.

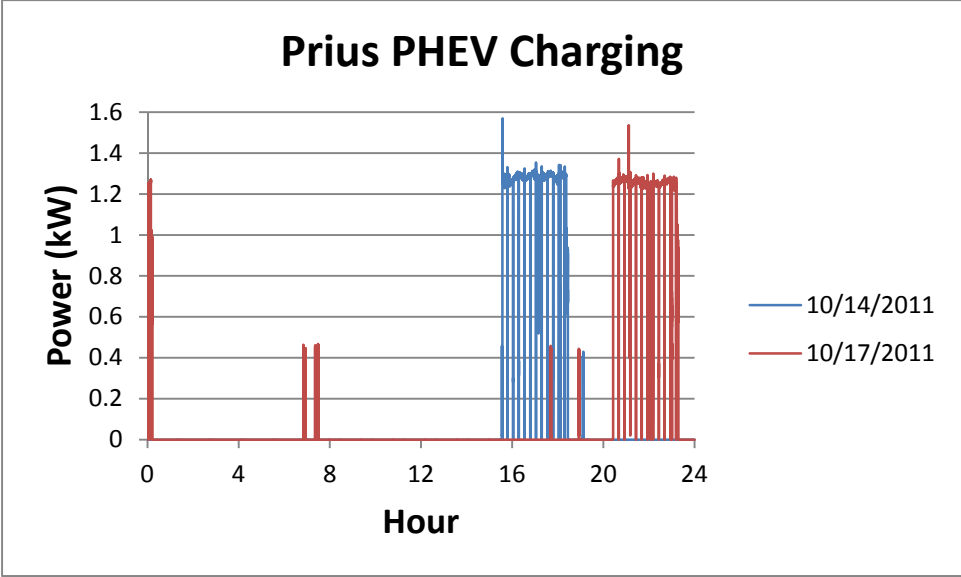

Figure 23. Level 1 Prius PHEV charging events at home

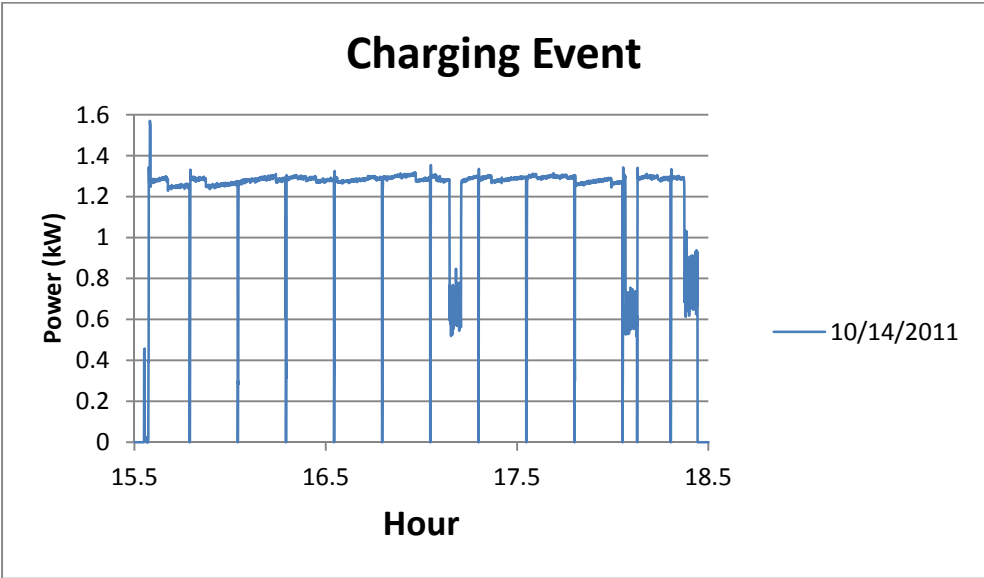

Figure 24. Zoomed in view of single charging event



Interestingly, voltage levels measured at the charging outlet deviated beyond of the required range during both of the charging events. This phenomenon is demonstrated in Figure 25. The utility is required to maintain a voltage from 114-126 V at the service entrance [55], but it has no responsibility to maintain those voltage levels within the home. It is the utility customer's responsibility to provide adequate voltage levels for their electrical and electronic equipment. Knowing that this situation can occur, electric equipment manufacturers design their product to tolerate a larger voltage range than what is specified in ANSI C84.1-1995.

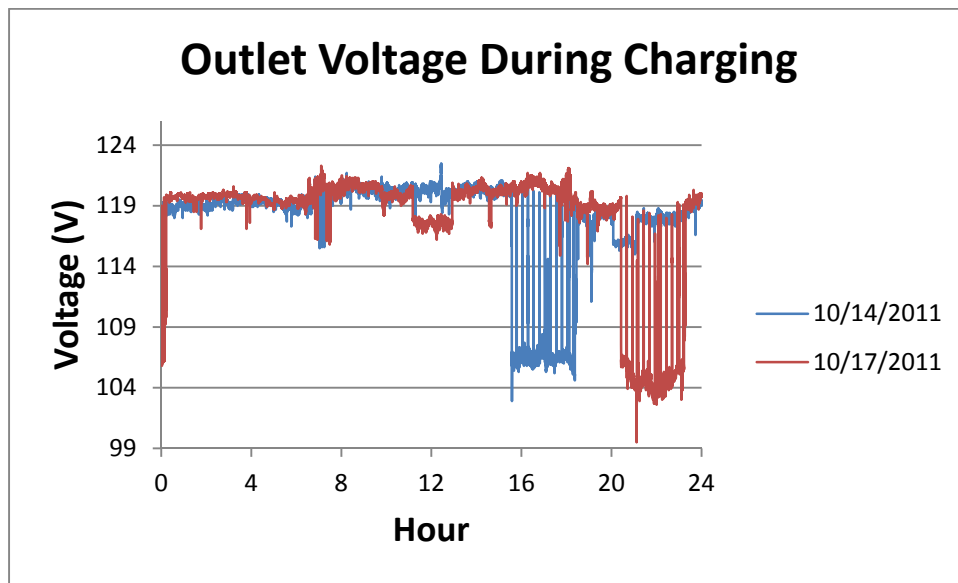

Figure 25. Voltage measured at outlet during charging events

## **8 TASK 5 RESULTS: SMART GRID TECHNOLOGY MANAGEMENT**

### **SCENARIOS**

Homeowner demand for rooftop photovoltaic (PV) systems coupled with energy storage is expected to grow as more homeowners choose to generate a portion of their power needs locally. When large amounts of distributed generation are installed on the secondary distribution circuit, the distribution system no longer operates according to its standard central power generation model. Introducing high penetrations of local generation, such as solar photovoltaic (PV) panels, can result in bi-directional power flow potentially overloading the nearest transformer creating the need to update local control and protection schemes.

One method to avoid this situation is to install energy storage near the local generation site. The Irvine Smart Grid Demonstration project is currently demonstrating the current state-of-the-art for energy storage on the secondary distribution circuit. The project has commissioned battery systems that use lithium battery technology similar to that used in an electric vehicle to store local excess solar PV generation.

Examples of computer simulation results, based on computer models developed for the different technologies considered here, are describe in this section. Simulations were run using varying levels of measured and simulated data that vary depending on the scenario modeled. Time series power flow on a residential secondary distribution circuit were characterized and modeled with and without distributed energy resources (DER) using MATLAB/Simulink. Rooftop solar PV, individual residential energy storage units (RESU), and shared community energy storage (CES) were considered. The overall approach applied when dispatching the energy storage systems was to flatten the evening load profile.

## 8.1 SINGLE FAMILY HOME WITH ROOFTOP SOLAR AND ENERGY STORAGE

Figure 26 shows sample data used to model the 24 hour, real power, demand profile of a 1,500 ft<sup>2</sup>, Southern California home. The model for this home includes a 3.5 kW DC rooftop photovoltaic, 4 kW/10 kWh energy storage system, and uncontrolled electric vehicle charging. The demand profile used in this example is based on measured data for a spring weekday. The weather on this day was 72°F and sunny. The residential energy storage system battery is charged using excess solar generation and is discharged beginning at 6:00 PM using a load following, time based discharge approach. Electric vehicle charging begins at 6:15 PM.

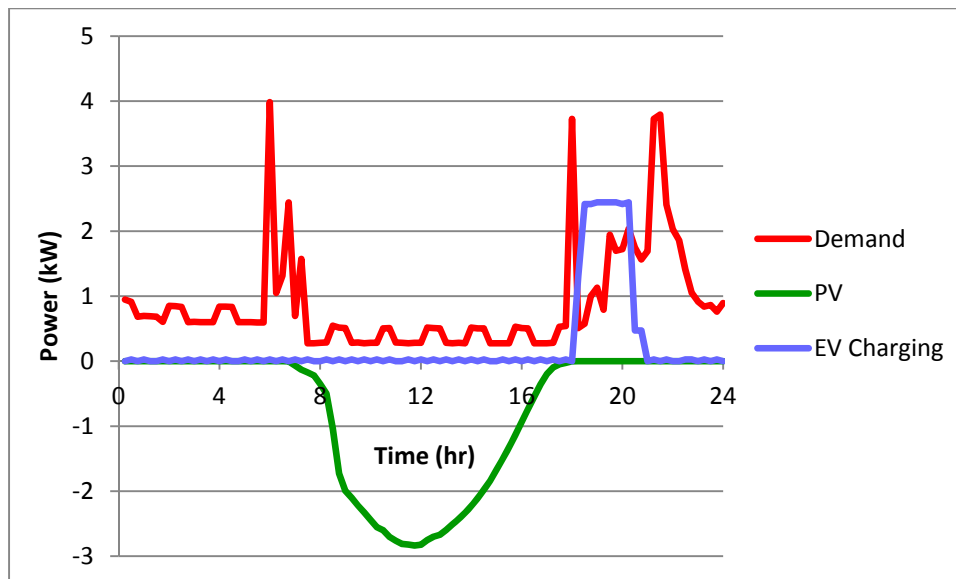

Figure 26. Sample power demand and generation profiles at one home

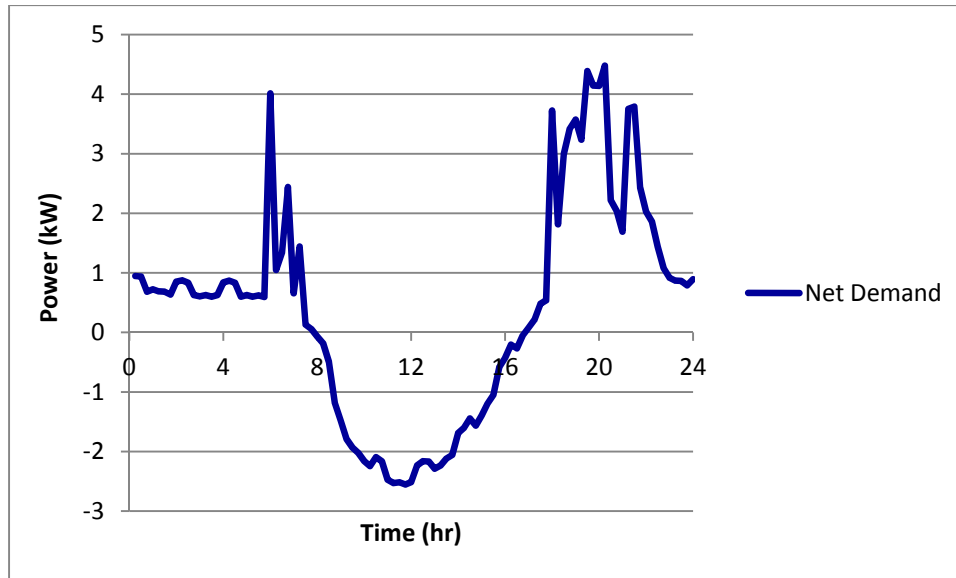

Figure 27. Net load profile for one home

Excess generation due to the solar PV (as can be seen in Figure 27) results in a local reverse power flow at the home’s service entrance. To combat reverse plow flow, a homeowner can employ a residential energy storage unit (RESU) that will charge a battery using the excess solar produced and then dispatch this power at another time of day. The battery can also be charged using power from the electric grid when solar power production is not available. The following battery dispatch scenarios are considered: 1) time based, load following discharge; 2) time based, constant power discharge; and 3) resizing the battery to fit the energy needs of the home. All examples presented assume that solar power is used to charge the RESU at a rate of 0.9 C until the battery reaches its rated storage capacity of 10 kWh. The battery is modeled to discharge up to its rated 10 kWh capacity.

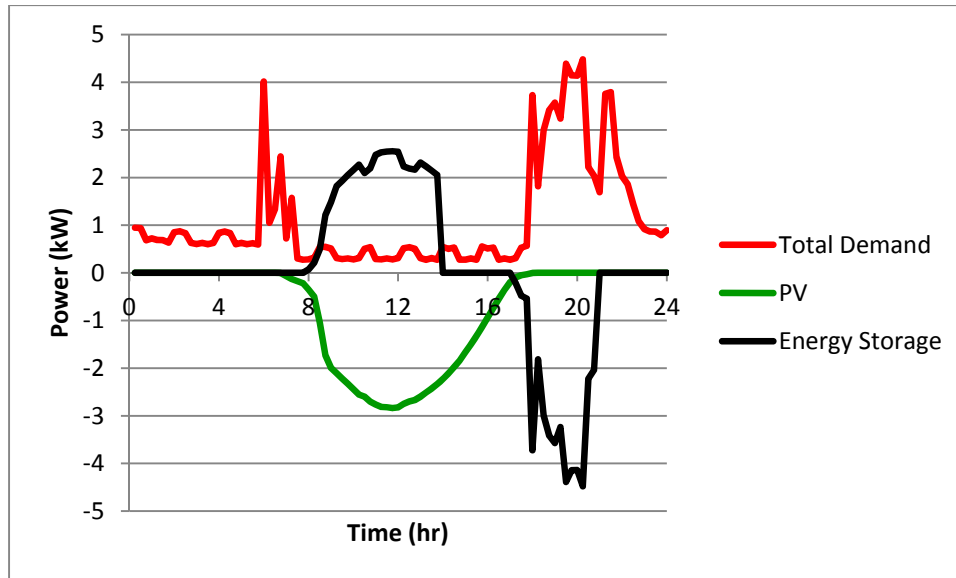

Figure 28. RESU charge/discharge cycle using load following time based control

Figure 28 demonstrates the charging and discharging profile for a single RESU set to charge using solar power generation and discharge beginning at 6PM using a load following approach. The battery is assumed to be fully discharged at the start of the charging event. When this charge/discharge strategy is applied, the battery completes its charging process by 2:15 PM. At 6:00 PM, the battery begins to serve the entire load of the home. The battery is fully discharged by 8:45 PM. At this time the EV is still charging, so the home consumes 3.75 kW from the grid, thereby causing a large spike in power use later in the evening. Eliminating the need to supply power to the home in the early evening helps to reduce the steep ramp up in demand at the time of day when solar power production is waning and the home's demand is increasing. The resulting load profile is shown in Figure 29.

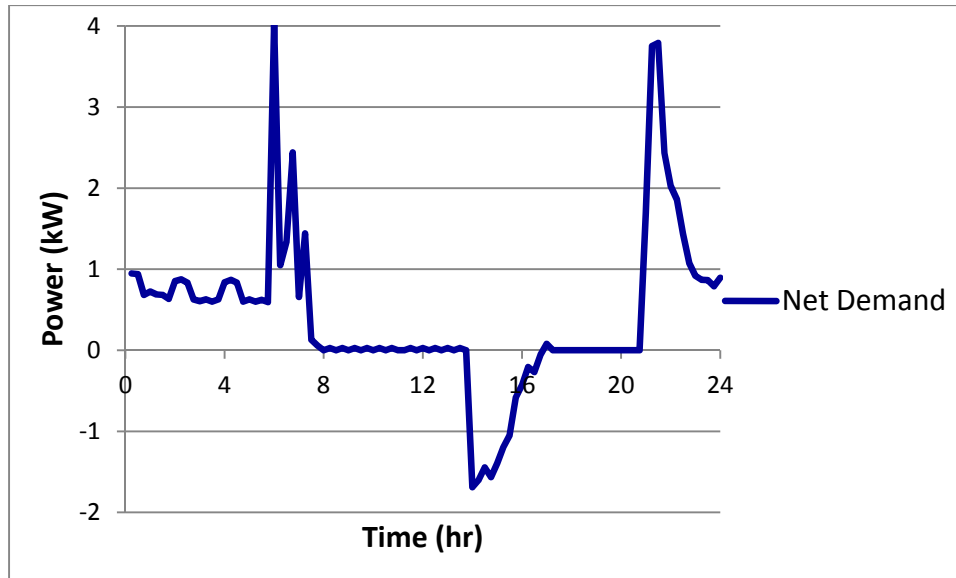

Figure 29. Resulting load profile of home with load following RESU

Evening power spikes of this type could become a concern for the utility if widespread adoption of electric vehicles and energy storage occurs in clusters. A steep ramp up in demand across the distribution system is undesirable for the utility. Power must be generated at the moment it is consumed, so sudden increases in demand require generators to increase their power output quickly. This can be challenging for traditional generators.

In order to extend the length of time the battery is available to provide load support to the home, a constant discharge strategy is applied. The battery will discharge up to 2 kW until it reaches its rated capacity. The constant discharge strategy is illustrated in Figure 30. Applying a constant power discharge strategy will help to reduce the steep ramp that occurs later in the evening, but does not eliminate it. With the constant power discharge strategy applied to a RESU home, the resulting net demand profile is also shown in Figure 30.

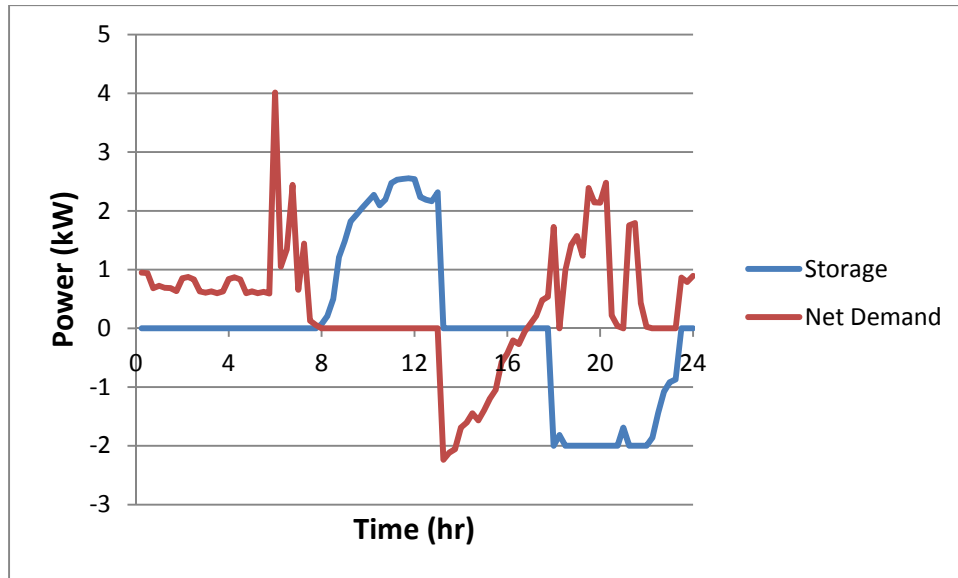

Figure 30. RESU 2 kW constant power discharge strategy

Sizing the RESU according to an individual home’s average evening energy use can help to flatten the evening load profile. Historical home demand profiles and past solar power production profiles at a particular location need to be considered when determining the appropriate size for an energy storage system for a particular home.

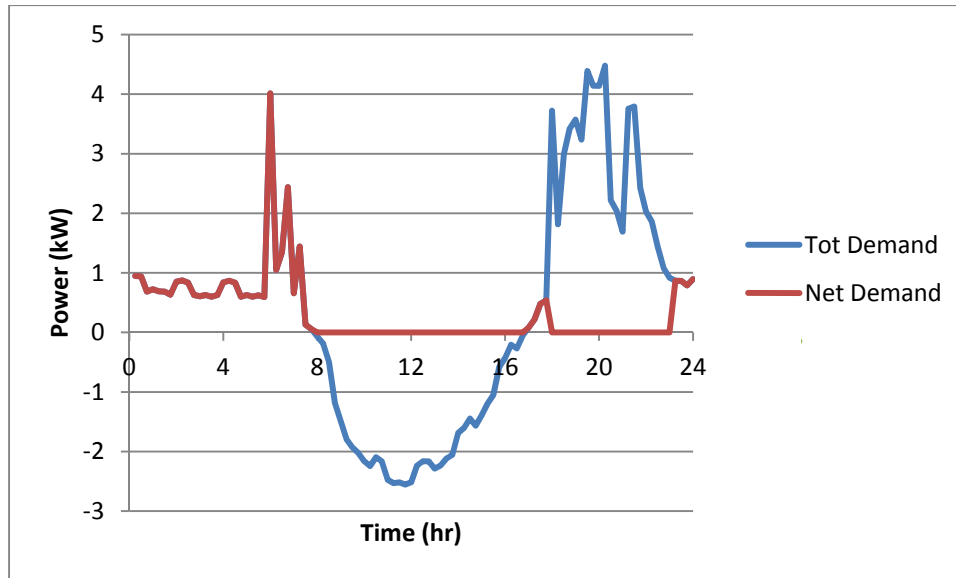

Figure 31. RESU sized to match net solar production

## 8.2 RESIDENTIAL STREET WITH HIGH PENETRATION OF SOLAR, ELECTRIC VEHICLE CHARGING & INDIVIDUAL ENERGY STORAGE

The modeling approach described in above in section 8.1 can be applied to a block of homes that are electrically connected to a shared secondary distribution transformer. The resulting load profile of 7 homes with 3.5 kW rooftop solar photovoltaic (PV) panel systems, 4 kW/10 kWh energy storage systems and uncontrolled electric vehicle charging are considered.



Figure 32, below, illustrates the load profiles considered for the example described in this section. The net load profiles for each home and at the secondary distribution transformer include measured PV generation and demand for each home and modeled EV charging events. The resulting profiles show reverse power flow both at the service entrances of the homes as well as at the secondary distribution transformer. These profiles represent loads for a set of 2,200 ft<sup>2</sup> -2,2700 ft<sup>2</sup> homes on a mostly sunny, spring, weekday with a temperature high of 72°F.

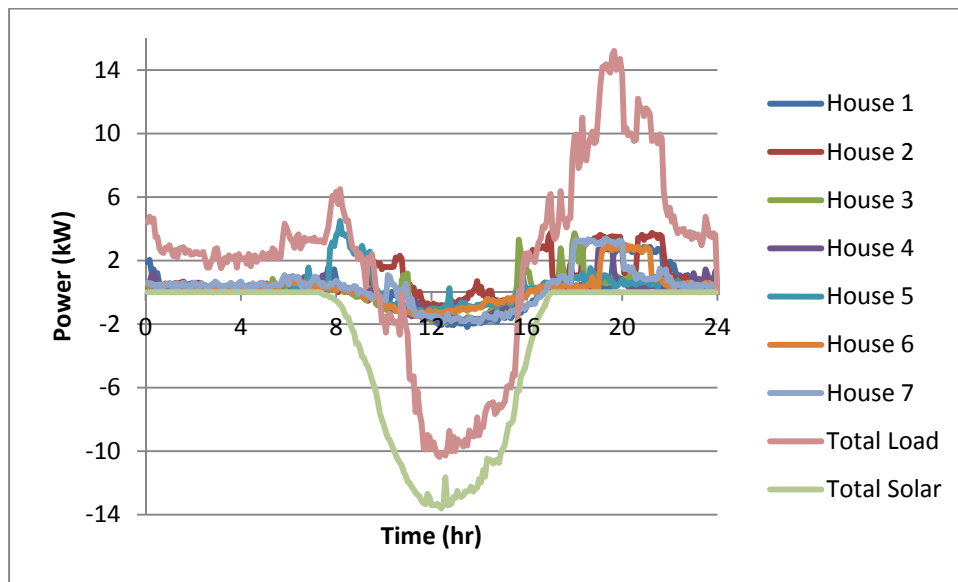

Figure 32. Load profiles for a block 7 of homes with rooftop solar and EV charging

Electric vehicle charging events modeled for this example are random in that the cars can begin charging at any time, but skewed so that most cars tend to begin charging in the evening. Charging events are uncontrolled in the sense that charging begins immediately when the car is plugged in and no delay in charge start time is allowed. Battery packs are assumed to be fully discharged and charging always occurs at Level 2, 2.5kW. All homes are assumed to drive the same type of EV (12 kWh battery). Charging events modeled for each home in this example are presented in Figure 33.

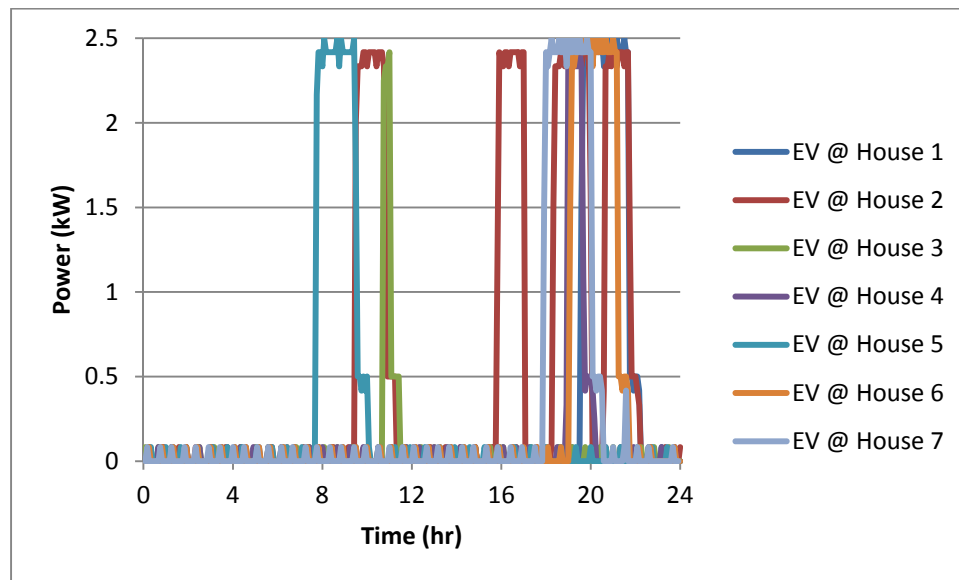

Figure 33. Modeled electric vehicle charging events

Next each home is given an energy storage system capable of storing energy from the grid or from excess solar generation. By storing excess solar generation at each home, the homeowner is able to use more of the power which is generated on her roof. In addition, any excess generation at an individual home is used to charge the battery of a neighboring home instead of flowing out back onto the grid. For simplicity, all energy storage systems are set to begin discharging at 6:00 PM using a load following approach.

For the example shown in Figure 34, reverse power flow through the transformer is effectively eliminated. This load profile was achieved due to the fact that, on this particular day, the total solar generation for every PV system on the modeled street matched well with the sum of the midday demand and the energy storage capabilities of the installed batteries.

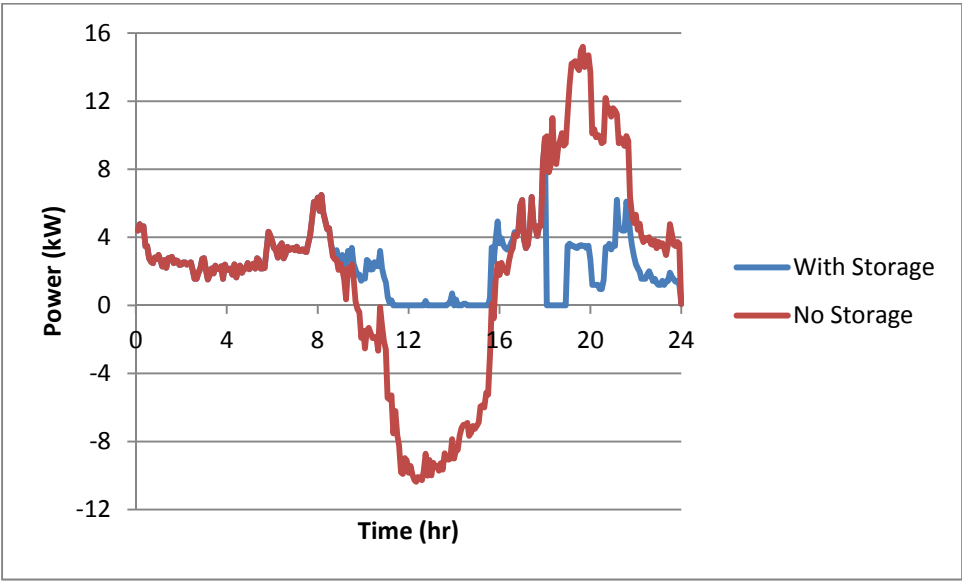

Figure 34. Load profile at transformer for block with individual energy storage units

### **8.3 RESIDENTIAL STREET WITH HIGH PENETRATION OF SOLAR, ELECTRIC VEHICLE CHARGING, AND SHARED ENERGY STORAGE**

A similar modeling approach was applied to a transformer load profile for a block of 9 homes that share a transformer and a single, Community Energy Storage (CES) battery. The modeling results in this section use measured secondary distribution transformer load data, a modeled 25 kW/ 50 kWh CES energy storage system, modeled rooftop solar PV at 7 homes, and uncontrolled vehicle charging events at 7 homes. This scenario was designed to represent a high penetration of distributed energy resources at the residential street level. The results are based on a sunny, 72°F, spring, weekday, load profile. Both load following and constant power discharge strategies are considered.

#### **8.3.1 Load Following Discharge**

The CES battery is charged using only excess solar power generation that is available from the PV systems located downstream from the device. In this example, excess solar generation provides 47.5 kWh of energy that can be stored in the battery. Although this amount is slightly less than the rated 50 kWh of storage capability, this example was chosen to demonstrate that it is possible to charge the battery to 93% of its rated capacity (losses due to AC/DC conversions are included) using only excess solar PV generation. The CES model can also be programmed to charge the battery using power from the grid. Figure 35 provides the resulting 24 hour load profile seen at the transformer for a load following discharge strategy set to begin at 6:00 PM. While the CES is discharged using a load following strategy, the transformer sees zero load until the battery is fully discharged. However, when this approach is applied, the battery is fully discharged by 9:40 PM and results in a spike in power use as seen by the transformer.

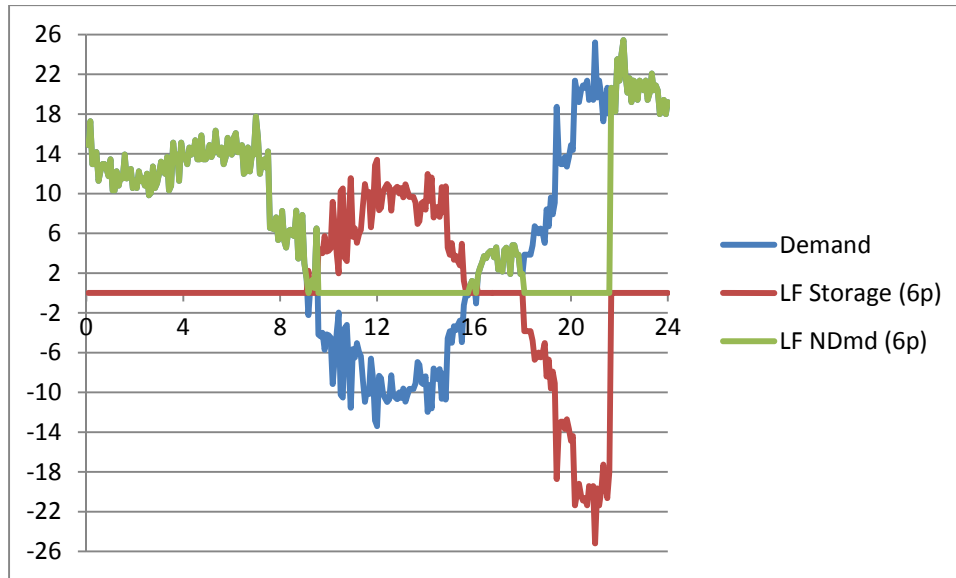

Figure 35. CES battery load following discharge beginning at 6pm

### 8.3.2 Constant Power Discharge

Next, a constant power discharge strategy is applied to help levelize the peak evening demand profile at the transformer and to increase the length of time that the CES is available to provide power. Three constant power discharge levels are considered: 25 kW, 12.5 kW, and 7.5 kW, at two separate time based discharge start times: 5:00 PM and 6:00 PM. Figure 36 shows the change in the evening demand curve for the 3 discharge power levels beginning at 6:00PM. Figure 37 shows the effect the CES battery has on the demand curve for the 3 discharge levels beginning at 5:00PM. In both the scenarios presented in Figure 36 and Figure 37, choosing a 7.5 kW constant discharge power provides the flattest demand curve for the evening hours.

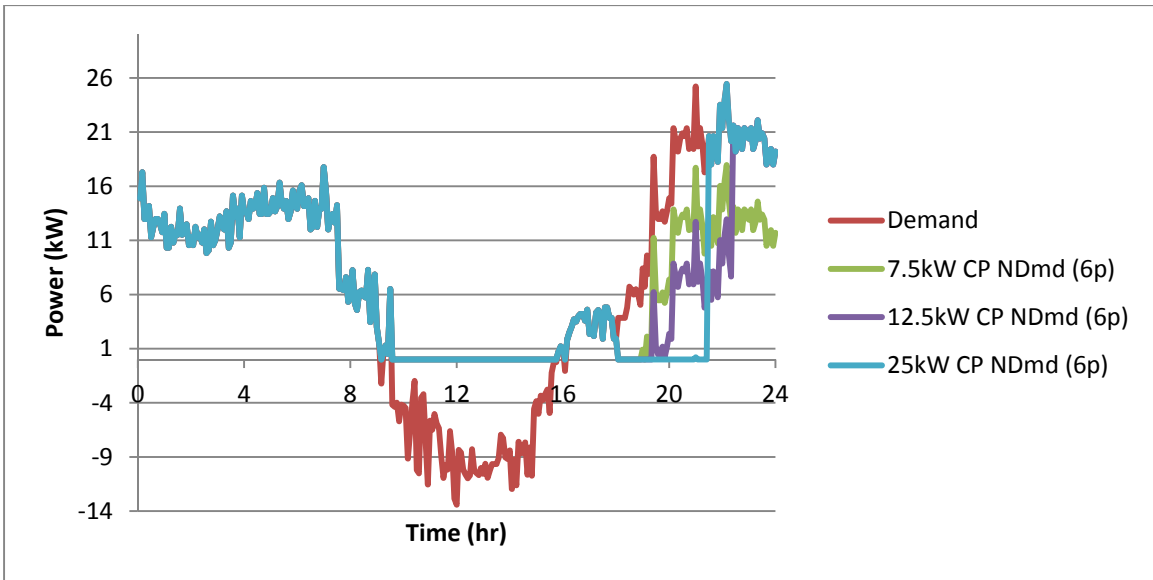

Figure 36. CES constant power discharge scenarios beginning at 6PM

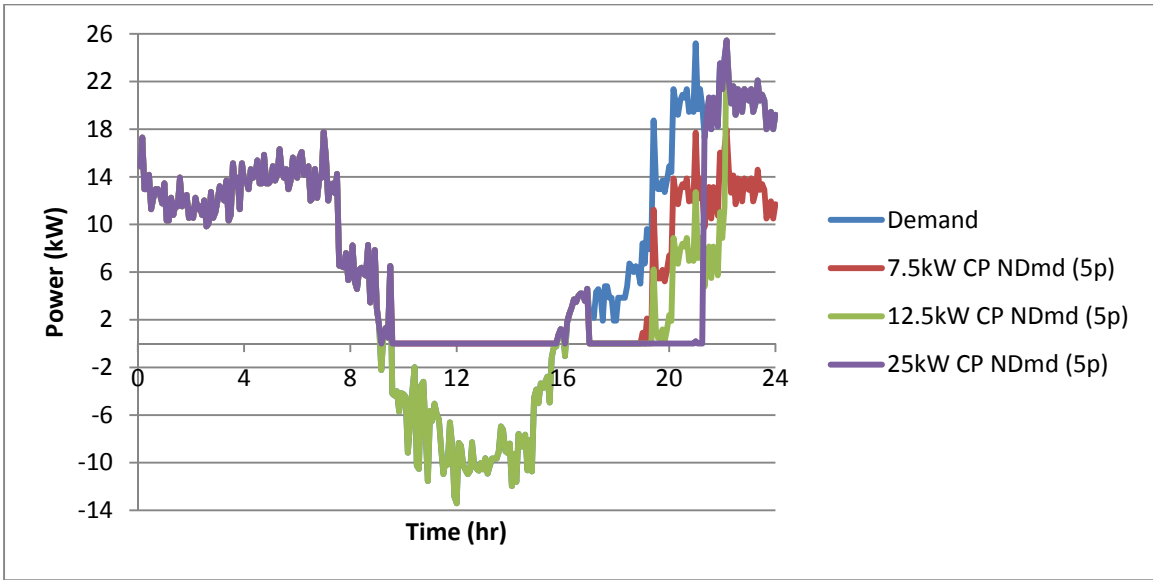

Figure 37. CES constant power discharge scenarios beginning at 5PM

## 9 SUMMARY AND CONCLUSIONS

### 9.1 SUMMARY

The effort to modernize the nation's aging electric delivery infrastructure is a long term effort known as "Smart Grid." The current system has inefficiencies, is congested, and unable to meet future power reliability, quality, sustainability (e.g., more renewable power) and security needs. Transition to a smart grid will occur over time.

This research addresses one area of electric power system modernization, namely the impacts that high penetrations of distributed energy resources (DER), such as solar PV, batteries, and plug-in electric vehicles (PEVs) could have on the distribution system by (1) evaluating the effect of introducing large amounts of DER and PEV charging on a secondary distribution circuit and (2) developing, applying and evaluating smart grid dispatch management scenarios that can reduce consumer electricity costs and flatten residential home and circuit load profiles.

The improved load profiles presented herein demonstrate that traditional residential load profiles are reshaped when rooftop solar, energy storage, and plug-in electric vehicles are installed on the circuit. The newly shaped load profiles can also be manipulated by applying smart dispatch management to produce load profiles that are desirable. By allowing excess solar generation to flow back onto the grid or by dispatching batteries during peak load times, the load profile of an individual home or a secondary distribution transformer can be altered in a manner that benefits the distribution grid.

## 9.2 CONCLUSIONS

Based on the research conducted in this Thesis, the following conclusions can be drawn:

- **Detailed system level specifications for electrical signal measurement must be developed during the system design phase in order to facilitate data analyses.**

While working with multiple measurement technologies from different vendors, it became apparent that there were many inconsistencies across the system with how the data were collected. At the beginning of the project common data resolutions should be specified across all measurement systems whenever possible. Data should be stored with synchronized time stamps and time stamps should be recorded when data are collected, not when they are transmitted. It is also extremely important to specify details regarding the level of precision required during measurement and to specify that the measurement system have the ability measure current flow in both directions. System engineers should also take steps to ensure that the wireless transfer of data be robust, otherwise specify wired technologies for data transfer. In addition, consideration should be given about how the measurement devices will be powered. If the devices will be powered by batteries, battery replacement strategies should be specified.



- **Energy Storage coupled with rooftop solar PV and controlled electric vehicle charging can drastically change the load profile at the service entrance of the home and at the secondary distribution transformer. Adding more sophisticated controls to the energy storage system will help to predict the best method to shift load and to reduce energy costs.**

Energy storage can be dispatched to shift peak load, store excess solar PV generation, and provide backup power. The approach used to charge/discharge the battery depends on the particular stakeholder's needs. Time based charge/discharge, constant power charge/discharge, demand capping, and load leveling approaches have been demonstrated. Varying levels of control system sophistication can be built into the system as needed.

Residential energy storage systems should be controlled by the homeowner with utility override capability available only during demand response events. Controls built into this type of system will need to be easy to setup by the homeowner. Variables such as weather, day of week, holidays, historical loads, and historical solar PV production should be taken into consideration by the control algorithms. A learned charging/discharging behavior based on these variables is desirable so that the homeowner is not required to constantly make changes to the system.

The approach to manage a community energy storage system is different since it will likely be a utility owned asset. The utility will dispatch the battery according to its needs and not necessarily according to the needs of individual home owners. Applying control strategies to reduce the steep ramp that occurs as solar PV production wanes and the evening peak begins

should be a higher priority for the utility than, say dispatching the battery to save on energy costs for the homeowner. Level demand, cap demand and backup power strategies will also help to reduce the grid stressing, evening peak.

Energy storage dispatch management scenarios have been shown in this Thesis to be capable of managing 5-minute demand profiles that include rooftop solar PV, electric vehicle charging, and smart appliances. Dispatch management concepts that support secondary distribution load smoothing while meeting both individual resident demands and utility demands have been advanced. Further work to improve the response of the controls is justified.

### 9.3 RECOMMENDATIONS FOR FUTURE WORK

Based on the research conducted in this Thesis, continued research in the following areas is warranted:

- **Improved policies should be developed to facilitate involvement in net energy programs by both the utility and customers participating in residential distributed generation projects.**

CPUC Section 2827 requires that the utility credit net energy metering (NEM) customers for excess generation at the same retail rate that they are charged. Moreover, utilities are not allowed to charge any fees to serve the customer as a backup generation source. This arrangement causes the utilities to lose income that could otherwise be used to maintain and upgrade the grid. Without subsidies from state and federal government, utilities have little incentive to allow interconnections of large numbers of small scale, distributed generation systems.

Revising policies to include incentives for the utility to offset income lost due to onsite generation will enable utilities to recover some of their lost income. Instituting a nominal standby fee will help utilities to recover operations and maintenance income that is lost when customers do not purchase energy from the utility. Crediting excess generation at a rate less than retail will also help the utility business remain viable.

Obviously from the perspective of the retail customer and the distributed generation system provider, this arrangement is less desirable. However, as technology improves and demand for distributed generation increases the cost to purchase these systems will decrease thereby decreasing capital costs associated with purchasing these systems.

- **The IEEE technical standard 1547-2003 should be revised to ensure local reliability and stability of the electric power system by allowing distributed energy resources to control local voltage.**

Allowing DER to actively regulate the voltage and “ride through” voltage dips can increase the amount of time the DER generates and improve local reliability. Providing local power factor control through reactive power support can also be used to maintain system voltage requirements. Inverter based DG, like rooftop solar PV systems, can easily provide reactive power to the grid. If allowed, voltage regulation and circuit protection schemes imposed by the utility will also need to be revised. Additional communications, sensing, and switching devices will undoubtedly be needed along the circuit.

- **Improved policies should be developed to prevent low income families from carrying an excessive burden of support of the electric power system infrastructure operations and maintenance due to their inability to afford installing distributed generation at their residences.**

Homeowners with the financial resources to install DER in their home to save money on electricity costs will in the long run purchase less energy from the utility, resulting in the unintended consequence of placing the burden of infrastructure costs on the customers who do not have the means to own property and install distributed generation. A holistic study of the environmental, public health, societal benefits, and monetary costs involved in this situation is warranted.

## 10 REFERENCES

- [1] Litos Strategic Communication, "What a Smart Grid Means to Our Nation's Future." U.S. Department of Energy, 2009.
- [2] G. Constable and B. Somerville, *A Century of Innovation: Twenty Engineering Achievements That Transformed Our Lives*. Joseph Henry Press, 2003.
- [3] Litos Strategic Communication, "What the Smart Grid Means to You and the People You Serve." U.S. Department of Energy, 2009.
- [4] "Electricity Data Browser - Retail Sales of Electricity," *www.eia.doe.gov*, 25-Nov-2013. [Online]. Available: <http://www.eia.gov/electricity/data/browser/#/topic/5?agg=0,1&geo=g&endsec=vg&linechart=ELEC.SALES.US-ALL.A~ELEC.SALES.US-RES.A~ELEC.SALES.US-COM.A~ELEC.SALES.US-IND.A&columnchart=ELEC.SALES.US-ALL.A~ELEC.SALES.US-RES.A~ELEC.SALES.US-COM.A~ELEC.SALES.US-IND.A&map=ELEC.SALES.US-ALL.A&freq=A&start=2001&end=2012&ctype=linechart&ltype=pin&maptype=0&rse=0&pin=ELEC.SALES.US-RES.A~ELEC.SALES.US-COM.A~ELEC.SALES.US-IND.A>. [Accessed: 25-Nov-2013].
- [5] U.S. Energy Information Administration, "Annual Energy Outlook 2010," DOE/EIA-0484(2010), Jul. 2010.
- [6] Litos Strategic Communication, "The Smart Grid: An Introduction." U.S. Department of Energy, 2008.
- [7] U.S.-Canada Power System Outage Task Force, "Final Report on the August 14, 2003 Blackout in the United States and Canada: Causes and Recommendations," Apr. 2004.
- [8] Executive Office of the President, "Economic Benefits of Increasing Electric Grid Resilience to Weather Outages," Aug. 2013.
- [9] T. Gönen, *Electric Power Distribution System Engineering*. New York: McGraw-Hill, 1986.

- [10] J. J. Burke, *Power Distribution Engineering: Fundamentals and Applications*. New York: Marcel Dekker, Inc., 1994.
- [11] T. A. Short, *Electric Power Distribution Handbook*, 1st ed. CRC Press, 2003.
- [12] J. D. Glover, M. S. Sarma, and Overbye, *Power System Analysis and Design. Fifth Edition*, 5th ed. Stamford, CT: Cengage Learning, 2012.
- [13] U.S. Department of Energy, Office of Electric Transmission and Distribution, “Grid 2030’-A National Vision for Electricity’s Second 100 Years.” Jul-2003.
- [14] Hamachi LaCommare, Kristina and J. Eto, “Understanding the Cost of Power Interruptions to U.S. Electricity Consumers,” Ernest Orlando Lawrence Berkeley National Laboratory, LBNL-55718, Sep. 2004.
- [15] H. Farhangi, “The path of the smart grid,” *IEEE Power and Energy Magazine*, vol. 8, no. 1, pp. 18–28, 2010.
- [16] National Institute of Standards and Technology, “Draft Report on the NIST Framework and Roadmap for Smart Grid Interoperability Standards, Release 2.0,” NIST Special Publication 1108R2, Feb. 2012.
- [17] J. Bubic, R. Walling, K. O’Brien, and B. Kroposki, “The sun also rises,” *IEEE Power and Energy Magazine*, vol. 7, no. 3, pp. 45–54, 2009.
- [18] A. Ipakchi and F. Albuyeh, “Grid of the future,” *IEEE power and energy magazine*, vol. 7, no. 2, pp. 52–62, Apr. 2009.
- [19] *Energy Independence and Security Act of 2007*. 2007, p. 310.
- [20] *American Recovery and Reinvestment Act of 2009*. 2009, p. 407.
- [21] White House Blog, “Signed, sealed, delivered: ARRA | The White House,” 17-Feb-2009. .

- [22] "SmartGrid.gov: Smart Grid Demonstration Program," 2010. [Online]. Available: [http://www.smartgrid.gov/recovery\\_act/overview/smart\\_grid\\_demonstration\\_program](http://www.smartgrid.gov/recovery_act/overview/smart_grid_demonstration_program). [Accessed: 07-Aug-2011].
- [23] T. Ackermann, G. Andersson, and L. Söder, "Distributed generation: a definition," *Electric Power Systems Research*, vol. 57, no. 3, pp. 195–204, Apr. 2001.
- [24] G. Pepermans, J. Driesen, D. Haeseldonckx, R. Belmans, and W. D'haeseleer, "Distributed generation: definition, benefits and issues," *Energy Policy*, vol. 33, no. 6, pp. 787–798, Apr. 2005.
- [25] M. F. Akorede, H. Hizam, and E. Pouresmaeil, "Distributed energy resources and benefits to the environment," *Renewable and Sustainable Energy Reviews*, vol. 14, no. 2, pp. 724–734, Feb. 2010.
- [26] U.S. Department of Energy, "Benefits of Demand Response in Electricity Markets and Recommendations for Achieving Them. A report to the United States Congress Pursuant to Section 1252 of the Energy Policy Act of 2005." Feb-2006.
- [27] M. H. Albadi and E. F. El-Saadany, "A summary of demand response in electricity markets," *Electric Power Systems Research*, vol. 78, no. 11, pp. 1989–1996, Nov. 2008.
- [28] California Public Utilities Commission, "About the California Solar Initiative," 01-May-2013. [Online]. Available: <http://www.cpuc.ca.gov/puc/energy/solar/aboutsolar.htm>. [Accessed: 01-May-2013].
- [29] R. A. Messenger and J. Ventre, *Photovoltaic Systems Engineering, Third Edition*, 3rd ed. CRC Press, 2010.
- [30] R. Fioravanti, K. Vu, and W. Stadlin, "Large-scale solutions," *IEEE Power and Energy Magazine*, vol. 7, no. 4, pp. 48–57, 2009.
- [31] "Electric Drive Sales," 30-Nov-2013. [Online]. Available: <http://www.electricdrive.org/index.php?ht=d/sp/i/20952/pid/20952>. [Accessed: 01-Dec-2013].



- [32] Michael Kintner-Meyer, Kevin Schneider, and Robert Pratt, "Impacts Assessment of Plug-in Hybrid Vehicles on electric utilities and regional U.S. Power Grids, Part 1: Technical Analysis." Pacific Northwest National Laboratory, Nov-2007.
- [33] EPRI, "Advanced Metering Infrastructure (AMI)." Feb-2007.
- [34] B. Mather, "Analysis of High-Penetration Levels of PV into the Distribution Grid in California," presented at the High Penetration Solar Forum, San Diego, California, Mar-2011.
- [35] J. D. Payne, "Analysis of Distribution Circuits with High Penetrations of Photo-Voltaic Generation and Progressive Steps to Enable Higher Penetrations," UNIVERSITY OF CALIFORNIA, IRVINE, 2013.
- [36] F. Lambert, "Final Report, Secondary Distribution Impacts of Residential Electric Vehicle Charging," PIER-CEC, P600-00-039, May 2000.
- [37] S. Shao, M. Pipattanasomporn, and S. Rahman, "Challenges of PHEV penetration to the residential distribution network," in *IEEE Power Energy Society General Meeting, 2009. PES '09*, 2009, pp. 1–8.
- [38] K. Clement-Nyngs, E. Haesen, and J. Driesen, "The Impact of Charging Plug-In Hybrid Electric Vehicles on a Residential Distribution Grid," *IEEE Transactions on Power Systems*, vol. 25, no. 1, pp. 371–380, Feb. 2010.
- [39] P. Richardson, D. Flynn, and A. Keane, "Local Versus Centralized Charging Strategies for Electric Vehicles in Low Voltage Distribution Systems," *IEEE Transactions on Smart Grid*, vol. 3, no. 2, pp. 1020–1028, Jun. 2012.
- [40] H.-D. Chiang, J.-C. Wang, C.-T. Huang, Y.-T. Chen, and C.-H. Huang, "Development of a dynamic ZIP-motor load model from on-line field measurements," *International Journal of Electrical Power & Energy Systems*, vol. 19, no. 7, pp. 459–468, Oct. 1997.
- [41] Litos Strategic Communication, "What the Smart Grid Means to Americans." U.S. Department of Energy, 2009.

- [42] Litos Strategic Communication, "How the Smart Grid Promotes a Greener Future." U.S. Department of Energy, 2009.
- [43] L. Dickerman and J. Harrison, "A New Car, a New Grid," *IEEE Power and Energy Magazine*, vol. 8, no. 2, pp. 55–61, Mar. 2010.
- [44] K. McDermott, "Cost of Service Regulation In the Investor-Owned Electric Utility Industry." EEI, Jun-2012.
- [45] Litos Strategic Communication, "What the Smart Grid Means to You and the People You Represent." 2009.
- [46] "Smart Grid Information Clearinghouse (SGIC)." [Online]. Available: <http://www.sgicclearinghouse.org/ConsumerAwareness>. [Accessed: 12-Feb-2014].
- [47] Litos Strategic Communication, "What the Smart Grid Means to America's Future." U.S. Department of Energy, 2009.
- [48] "Overview of the U.S. Standardization System. Voluntary Consensus Standards and Conformity Assessment Activities, 2nd Edition." American National Standards Institute (ANSI), 2007.
- [49] *California Renewable Energy Resources Act*. 2011.
- [50] California Public Utilities Commission, "California Renewables Portfolio Standard (RPS)," 2013. [Online]. Available: <http://www.cpuc.ca.gov/PUC/energy/Renewables/>. [Accessed: 14-Dec-2013].
- [51] California Public Utilities Commission, *California Public Utilities Code*, vol. 2821–2829. 2012.
- [52] Southern California Edison, "Rule 21, Generating Facility Interconnections." 20-Sep-2012.
- [53] "IEEE-SA - The IEEE Standards Association - Home," 02-Dec-2013. [Online]. Available: <http://standards.ieee.org/>. [Accessed: 02-Dec-2013].

- [54] IEEE SCC21, "IEEE Standard for Interconnecting Distributed Resources With Electric Power Systems," *IEEE Std 1547-2003*, pp. 1–16, Aug. 2003.
- [55] ANSI, "ANSI C84.1-2006 American National Standard for Electric Power Systems and Equipment--Voltage Ratings (60 Hertz)." National Electrical Manufacturers Association, 2006.
- [56] Underwriters Laboratories Inc., *UL 1741 Inverters, Converters, Controllers and Interconnection System Equipment for Use with Distributed Energy Resources*, 2nd ed. Underwriters Laboratories Inc., 2010.
- [57] "UL.com," 2013. [Online]. Available: <http://www.ul.com/global/eng/pages/>. [Accessed: 13-Dec-2013].
- [58] R. J. Yinger and A. E. Kamiab, "Good Vibrations," *Power and Energy Magazine, IEEE*, vol. 9, no. 5, pp. 22–32, Oct. 2011.
- [59] R. J. Yinger, S. S. Venkata, and V. A. Centeno, "Southern California Edison's Advanced Distribution Protection Demonstrations," *Smart Grid, IEEE Transactions on*, vol. 3, no. 2, pp. 1012–1019, Jun. 2012.
- [60] "SunPower E-Series Solar Panel Data Sheet." SunPower Corporation, Apr-2013.
- [61] J. A. Gow and C. D. Manning, "Development of a photovoltaic array model for use in power-electronics simulation studies," *Electric Power Applications, IEE Proceedings -*, vol. 146, no. 2, pp. 193–200, Mar. 1999.
- [62] T.-Y. Kim, H.-G. Ahn, S. K. Park, and Y.-K. Lee, "A novel maximum power point tracking control for photovoltaic power system under rapidly changing solar radiation," in *IEEE International Symposium on Industrial Electronics, 2001. Proceedings. ISIE 2001*, 2001, vol. 2, pp. 1011–1014 vol.2.
- [63] C.-T. Pan, J.-Y. Chen, C.-P. Chu, and Y.-S. Huang, "A fast maximum power point tracker for photovoltaic power systems," in *The 25th Annual Conference of the IEEE Industrial Electronics Society, 1999. IECON '99 Proceedings*, 1999, vol. 1, pp. 390–393 vol.1.

- [64] Southern California Edison, "Schedule TOU-D-TEV, TIME-OF-USE-DOMESTIC TIERED ELECTRIC VEHICLE CHARGING, Cal. PUC Sheet No. 52076-E." 13-Aug-2013.
- [65] EIA, "How much electricity does an American home use? - FAQ - U.S. Energy Information Administration (EIA)," 2014. [Online]. Available: <http://www.eia.gov/tools/faqs/faq.cfm?id=97&t=3>. [Accessed: 15-Jan-2014].
- [66] SAE International, "J1772-Electric Vehicle and Plug-in Hybrid Electric Vehicle Conductive Charge Coupler." 15-Oct-2012.
- [67] SAE International, "Charging-what can be more simple?," 2010.