

UNIVERSITY OF CALIFORNIA, IRVINE

Direct Drive Hearing Aid Device

THESIS

submitted in partial satisfaction of the requirements
for the degree of

Master of Science
in Biomedical Engineering
by
Mehrnaz Mehrabi

Thesis Committee:
Professor Hamid Djalilian, Chair
Professor Arash Kheradvar
Associate Professor Harrison W. Lin

2021

DEDICATION

To

My parents and My sister who are my whole world

TABLE OF CONTENTS

| | Page |
|---|------|
| <u>LIST OF FIGURES AND TABLES</u> | iv |
| <u>ACKNOWLEDGEMENTS</u> | vi |
| <u>ABSTRACT OF THE DISSERTATION</u> | viii |
| <u>PREFACE</u> | 1 |
| <u>INTRODUCTION: The Technological Need of the Older Population</u> | 2 |
| <u>CHAPTER 1: Hearing Loss and Technology</u> | 22 |
| <u>1. Hearing Loss</u> | 22 |
| <u>2. Hearing Technology</u> | 24 |
| <u>Traditional Air Conduction Hearing Aids</u> | 24 |
| <u>Bone Anchored Hearing Aid (BAHA)</u> | 26 |
| <u>Cochlear Implants</u> | 28 |
| <u>Middle Ear Implants (MEIs)</u> | 31 |
| <u>Rion Device</u> | 32 |
| <u>Vibrant Soundbridge (VSB)</u> | 32 |
| <u>Soundtec Direct / Ototronix MAXUM Device</u> | 35 |
| <u>Otologics Middle Ear Transducer (MET) Carina® Device</u> | 37 |
| <u>Envoy Esteem</u> | 38 |
| <u>EarLens</u> | 39 |
| <u>3. Hearing Aid Use and Performance</u> | 41 |
| <u>Use</u> | 41 |
| <u>Performance</u> | 44 |
| <u>Minimum Requirements</u> | 52 |
| <u>CHAPTER 2: Direct Hearing Device (DHD)</u> | 57 |
| <u>1. Direct Hearing Device</u> | 60 |
| <u>2. Design and Prototype</u> | 61 |
| <u>3. Frequency Response</u> | 66 |
| <u>4. Total Harmonic Distortion and Noise</u> | 67 |
| <u>5. Comfortability</u> | 69 |

| | |
|---|-----|
| <u>CHAPTER 3: Direct Hearing Device Clinical Performance</u> | 71 |
| <u>1. Institutional Review Board – Human Clinical Performance</u> | 71 |
| <u>2. Clinical Performance Test – Design</u> | 71 |
| <u>3. Clinical Performance Test – Frequency</u> | 77 |
| <u>4. Clinical Performance Test – Effectiveness</u> | 79 |
| <u>5. Discussion</u> | 80 |
| <u>CHAPTER 4: Summary and Conclusions</u> | 86 |
| <u>1. Summary of Findings</u> | 88 |
| <u>2. Purpose Resolution based on Findings</u> | 90 |
| <u>3. Conclusions</u> | 92 |
| <u>4. Limitations</u> | 93 |
| <u>5. Recommendations for Implementation</u> | 97 |
| <u>6. Recommendations for Areas of Future Study</u> | 98 |
| <u>7. Thoughts on Study Completion</u> | 103 |
| <u>REFERENCES</u> | 105 |

LIST OF FIGURES AND TABLES

| | Page |
|---|------|
| Fig. 1 Projected Older Population in the United States..... | 4 |
| Fig. 2 Average Annual Healthcare Costs for Medicare Recipients..... | 4 |
| Fig. 3 Pellet and Magnet-Driven Hearing Device ¹⁷ | 6 |
| Fig. 4 Frequency Response After Insertion ¹⁷ | 6 |
| Fig. 5 Mass Loading Effect of the Pellet ¹⁷ | 7 |
| Fig. 6 Testing Device ¹⁷ | 7 |
| Fig. 7 Device Schematic Design ¹⁷ | 8 |
| Fig. 8 Laser Doppler ¹⁷ | 8 |
| Fig. 9 Frequency Response at Different Voltages ¹⁷ | 9 |
| Fig. 10 Comparison of Frequency Response ¹⁷ | 9 |
| Fig. 11 Placement of Device ¹⁸ | 10 |
| Fig. 12 Dimensions of Device ¹⁸ | 11 |
| Fig. 13 DHD Cross-section ¹⁸ | 11 |
| Fig. 14 Implant Surgery Location ¹⁸ | 12 |
| Fig. 15 Close-up of DHD ¹⁸ | 12 |
| Fig. 16 Coupling Frequency ¹⁸ | 13 |
| Fig. 17 Force Relationship ¹⁸ | 13 |
| Fig. 18 Middle Ear Frequency Response ¹⁸ | 14 |
| Fig. 19 Tympanic Membrane Coupling ¹⁸ | 14 |
| Fig. 20 Frequency of Decibels ¹⁸ | 15 |
| Fig. 21 Pure Tone Stimulation ¹⁸ | 15 |
| Fig. 22 Device ¹⁹ | 17 |
| Fig. 23 Creation of Device ¹⁹ | 17 |
| Fig. 24 Magnet in Ear ¹⁹ | 18 |
| Fig. 25 Insertion of Device ¹⁹ | 18 |
| Fig. 26 Frequencies with Background Noise ¹⁹ | 19 |
| Fig. 27 Frequencies Before and After Implantation ¹⁹ | 19 |
| Fig. 28 Differences in Frequencies per Ear ¹⁹ | 20 |
| Fig. 29 Difference in Decibels ¹⁹ | 20 |
| Fig. 30 Human Ear Anatomy ²³ | 22 |
| Fig. 31 Types of Hearing Aids ³¹ | 24 |
| Fig. 32 Phonak Mini BTE ³⁵ | 25 |
| Fig. 33 Phonak Lyric ³⁶ | 25 |
| Fig. 34 BAHA ⁴³ | 27 |
| Fig. 35 BAHA Surgical Procedure ⁴⁰ | 27 |
| Fig. 36 Cochlea Longitudinal Cross-Section ⁵¹ | 29 |
| Fig. 37 Cochlea Cross-Section | 29 |
| Fig. 38 Cochlear Implant ⁵⁴ | 30 |

| | |
|---|----|
| Fig. 39 MED-EL Cochlear Implant Electrode ⁵⁷ | 31 |
| Fig. 40 CochlearTM Hybrid Implant ⁵⁸ | 31 |
| Fig. 41 VSB Device ⁶⁶ | 33 |
| Fig. 42 VBS Animation ⁶⁶ | 34 |
| Fig. 43 VBS Placement ⁶⁶ | 34 |
| Fig. 44Sports Headband to Secure VBS ⁶⁶ | 35 |
| Fig. 45 MAXUM Implant Magnification | 36 |
| Fig. 46 MAXUM Implantation | 36 |
| Fig. 47 MAXUM Implant System | 37 |
| Fig. 48 Carina® Hearing Device | 38 |
| Fig. 49 Envoy Esteem® | 38 |
| Fig. 50 Envoy Esteem® ⁷⁶ | 39 |
| Fig. 51 First EarLens® Transducer System ⁸⁰ | 40 |
| Fig. 52 Second EarLens® Transducer System ⁸⁰ | 40 |
| Fig. 53 DHD Actuator with Detachable Tip | 61 |
| Fig. 54 Coupling Mockups for Testing | 62 |
| Fig. 55 Cup Test | 63 |
| Fig. 56 Cup Test Setup | 64 |
| Fig. 57 Frequency Testing | 65 |
| Fig. 58 Artificial Ear Testing | 65 |
| Fig. 59 Clinical Trial -- Stability | 66 |
| Fig. 60 Cup Test Frequency Results | 72 |
| Fig. 61 Cup Test Frequency Responses – Strong Coupling | 73 |
| Fig. 62 Cup Test Frequency Responses – Weak Coupling | 73 |
| Fig. 63 Microphone C Test Results | 75 |
| Fig. 64 Actuator Fittings | 76 |
| Fig. 65 Fabricated Device | 76 |
| Fig. 66 Fabricated Stinger | 77 |
| Table 1 Clinical Trial Results | 79 |
| Fig. 67 Clinical Trial Results – Frequency Response vs. Perceived Sound Level | 80 |

ACKNOWLEDGEMENTS

I would like to acknowledge everyone who played a role in my academic accomplishments. First of all, my parents and my sister, who supported me with love and understanding. Without them, I could never be who I am and where I am today. Secondly, I would like to express the deepest appreciation to my main mentor since I was an undergraduate student, Dr. Michelle Digman who always supported and guided me through my time at University of California, Irvine.

I would like to thank my advisor Dr. Hamid Djalilian for giving me the opportunity to join his team and be involved in such an incredible research. In addition, I would like to thank Dr. Mehdi Abouzari for his support and help. Also, I would like to thank my committee members, Dr. Arash Kheradvar and Dr. Harrison Lin. Thank you all for your unwavering support.

ABSTRACT OF THE DISSERTATION

Direct Drive Hearing Aid Device

By

Mehrnaz Mehrabi

Master of Science in Biomedical Engineering

University of California, Irvine, 2021

Professor Hamid Djalilian, Chair

This study serves as documentation for the design and creation of a direct-drive hearing aid device intended to sit in the inner ear canal of the individual with a diagnosis of moderate to severe hearing loss. The study was divided into two distinct parts. The first part of the study was focused on the design of the direct hearing device (DHD) and the creation of the prototypes for that device. The second part of the study consisted of a limited clinical trial intended to determine the effectiveness of the device. The results of the study indicate that the new design is feasible for production, it does amplify sound more effectively in comparison to currently available devices on the market, and preliminary findings indicate that the device is comfortable in the completion of common activities associated with use.

PREFACE

As a result of clinical problems faced by physicians, the current study was born in an effort to develop technological solutions to alleviate these problems. Traditionally, physicians have been seen to work with the Li-Bachman lab to develop applications that could be deployed and validated. My desire was to develop medical technology that would allow for monitoring, aiding, and assisting human functions from idea to prototype. I began this task by working closely with an otolaryngologist that specializes in hearing and balance. Our discussions were regarding potential issues faced in the field and how solutions could be developed using technology. A recurring theme was solutions for the older population. Unsurprisingly, Baby Boomers are aging and advanced technology will be required to effectively provide healthcare. However, there needs to be a deeper exploration regarding this population and, specifically, in relation the role held by technology in improving quality of life.

INTRODUCTION: The Technological Need of the Older Population

Recent studies show that the number of people with hearing loss are increasing on a global scale¹. The World Health Organization (WHO) estimates that more than 466 million people globally experienced disabling hearing loss (DHL) as of 2018, roughly 6.1% of the global population¹. It is estimated that these figures will continue to increase, with a projected estimate of more than 900 million people affected by DHL by 2050¹. In the United States alone, 2-3 children in every 1,000 are born with detectable hearing loss and roughly 15% of all American adults, defined as those over the age of 18, report some form of hearing loss². Still further, while age is a common predictor of hearing loss, with the majority of adult hearing loss reported in those aged 60 or older, it is not the only predictor and increased hearing loss has been seen in the number of adult males in their 20s². Indeed, roughly one out of every eight adults has some form of hearing loss². These figures show that the problem of hearing loss is not one that is only affecting the elderly, nor is it a problem that is only affecting certain segments of the population.

Of further consideration is the fact that recent societal changes brought about over the course of the past year suggest that there is the potential for the number of individuals experiencing hearing loss, as studies have correlated hearing loss with headphone usage at inappropriate volumes^{3,4}. The global pandemic has led to a great many changes to the way that the average individual conducts their day to day activities, including the increased integration of remote working and work from home^{5,6}. With this change from in office working to remote office work comes the change in the tools that are utilized, including the increasing use of online meetings and the use of headsets in the delivery of both meeting information and in the delivery of online schooling or virtual schooling, as compared to in person schooling⁷. These changes affect individuals of all ages. Still further, given that headphone or headset use is a contributing factor in

hearing loss, it is possible that, the previous projections regarding hearing loss,¹ will be far higher than anticipated, given the previously identified correlates regarding improper use of technology and hearing loss^{3,4}. In light of the current statistics regarding hearing loss, both at the national level and at the global level, there is a need to determine ways to address this growing concern.

Reports indicating the prevalence of hearing loss are focused on the identification of the scope of the problem^{1,2}. While these reports are helpful, they only address one facet of the problem. With the scope of the problem identified, and the projected rising prevalence of DHL within the general global population, the next question is what to do about the problem. There are two approaches that can be taken, one of prevention and one of treatment⁸. Those focused on prevention explore the ways through which hearing loss occurred within those members of the population who have already experienced hearing loss in order to identify guidelines that can be used to prevent further hearing loss or future hearing loss within given segments of the population⁸. The second approach is the identification of treatment options for DHL; in this group, researchers are focused on ways to treat the loss of hearing that has already occurred⁸. This second group, treatment options for DHL, is the approach that the current study adopts.

One of the more common treatments for hearing loss is the use of a hearing aid⁹. However, roughly 59% of those over the age of 50 who have hearing loss and who live in the United States do not utilize a hearing aid¹⁰ and only one out of three individuals who have a hearing aid use it regularly¹¹. One of the most common reasons for failing to use a hearing aid is cost¹². Other reasons for failure to use hearing aids are misconceptions regarding their use and negative attitudes associated with the use of hearing aids¹¹. Failure to properly treat hearing loss leads to certain consequences for the individual, depending on the type and degree of hearing loss experienced by

that individual¹³. Among the different consequences of hearing loss include reduced cognitive function, loss of productivity, and an overall lower quality of life¹³.

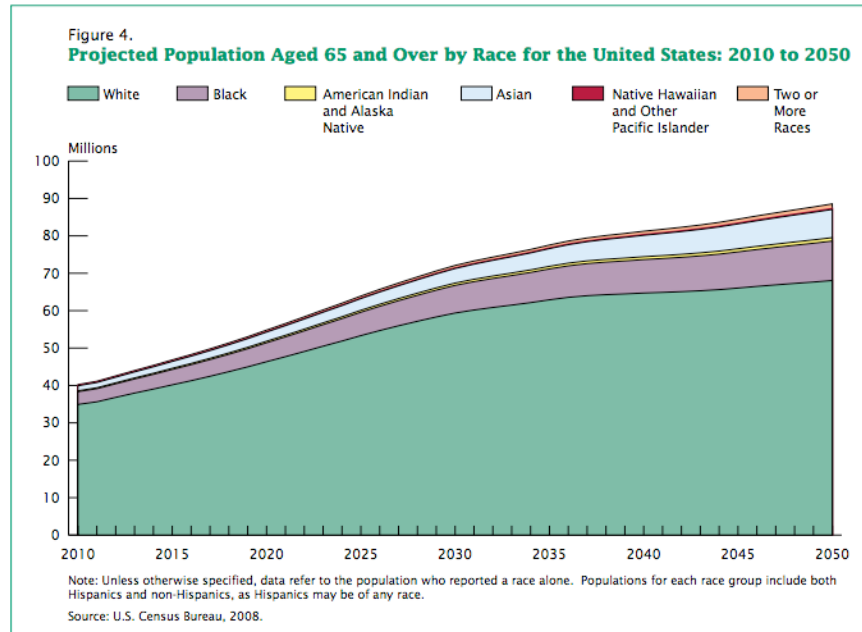

Fig. 1 Projected Older Population in the United States

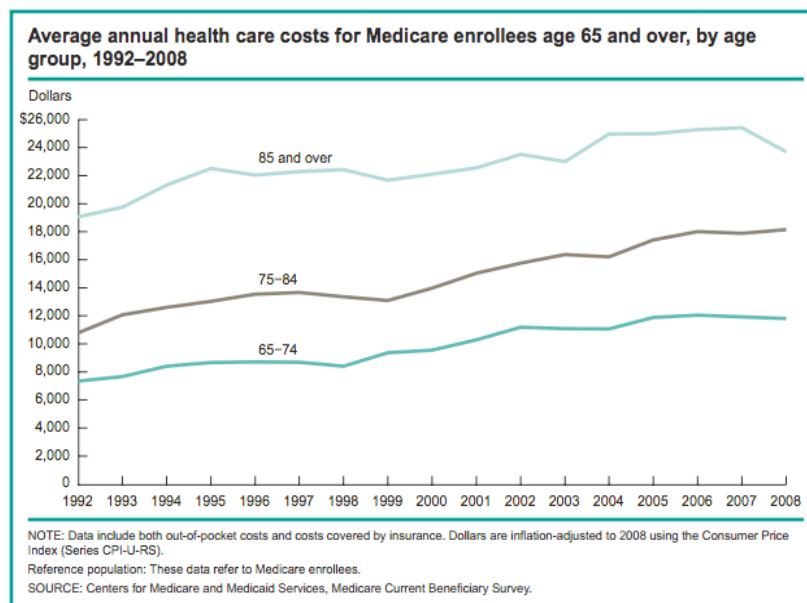

Fig. 2 Average Annual Healthcare Costs for Medicare Recipients

In recent years, the number of technological advancements in hearing aid technologies have increased dramatically^{14,15}. Some of the main technological problems associated with hearing aids are feedback, the occlusion effect, sound distortion, sound quality, inability to reduce background noises, ongoing maintenance needs, concerns regarding the physical fit of the device, and even difficulties associated with hearing aid handling, including adjusting aspects of the device while inserted or changing out batteries¹⁴. In order to address many of these limitations, one technological advancement in this area was a design shift toward the creation of implantable hearing devices¹⁶. Implantable hearing devices, henceforth referred to as implantable devices, are devices that avoid the ear canal entirely, negating previously identified problems associated with both chronic otitis and occlusion effects¹⁶. Still further, the use of implantable devices works to negate issues associated with distortion, feedback, and sound quality as they work to directly stimulate the cochlea through a coupling to the long process of the incus, round window membrane, or the stapes superstructure or footplate¹⁶. In spite of the ability of these devices to directly address many of the disadvantages associated with hearing aid use, they have several distinct disadvantages of their own, including the need for invasive and irreversible surgery to implant the devices, prohibitive costs, unknown performance levels until after the implantation of the device, and the need for surgery to remove the devices or replace the devices, should that be necessary for one reason or another¹⁶. In light of these downsides to the use of implantable devices, there is a continual need within the field of research to design, develop, and create new hearing aid prosthesis technologies in order to work to further reduce the adverse or detrimental effects associated with currently available technologies while keeping all of the advantages associated with currently available technologies.

Several researchers have been working toward the creation of hearing devices that can be used as alternatives to current approaches to hearing loss treatment¹⁷⁻¹⁹. An example is Mahboubi et al.'s¹⁷ completely-in-the-canal magnet-drive hearing device, shown below.

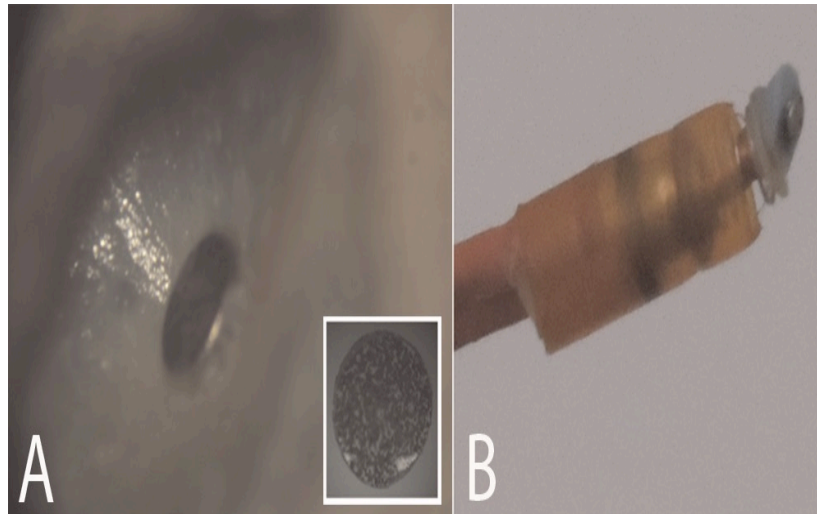

Fig. 3 Pellet and Magnet-Driven Hearing Device¹⁷

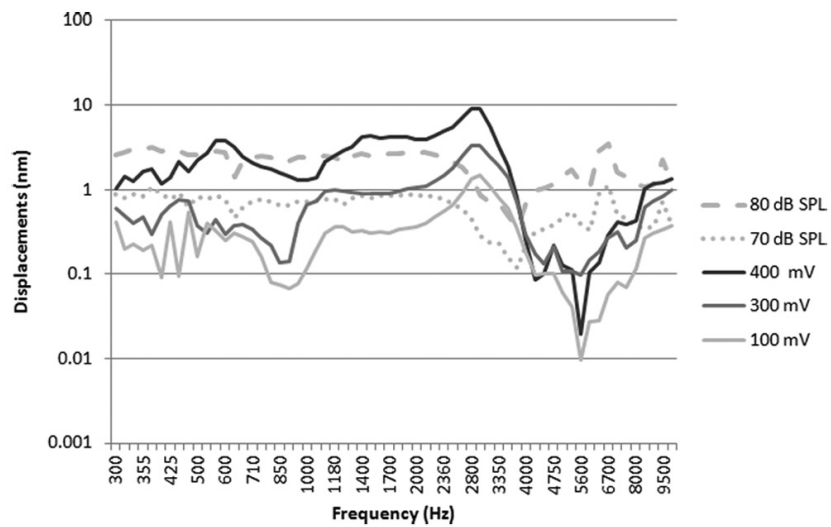

Fig. 4 Frequency Response After Insertion¹⁷

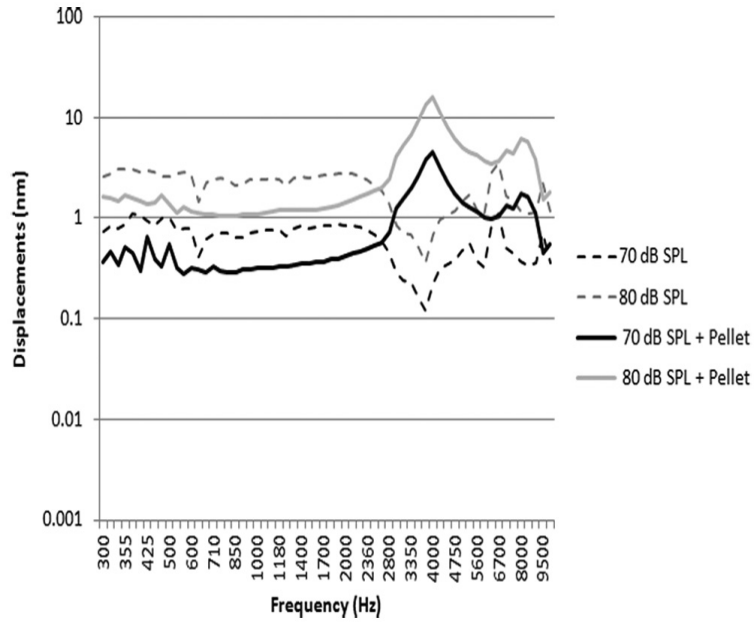

Fig. 5 Mass Loading Effect of the Pellet¹⁷

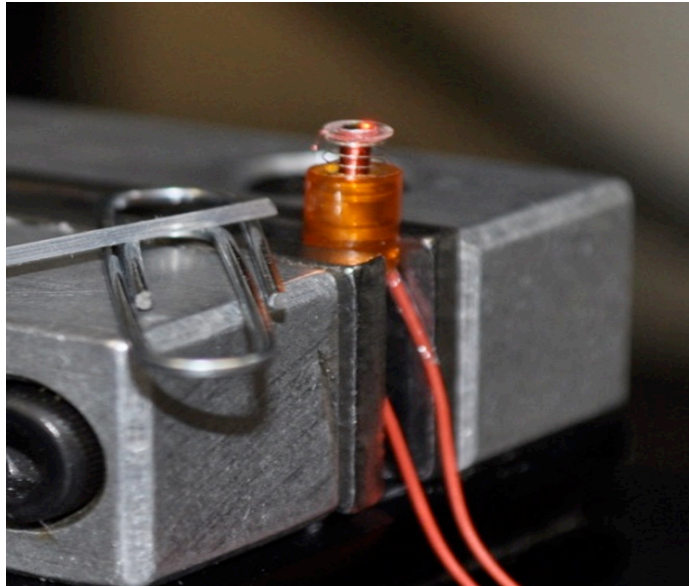

Fig. 6 Testing Device¹⁷

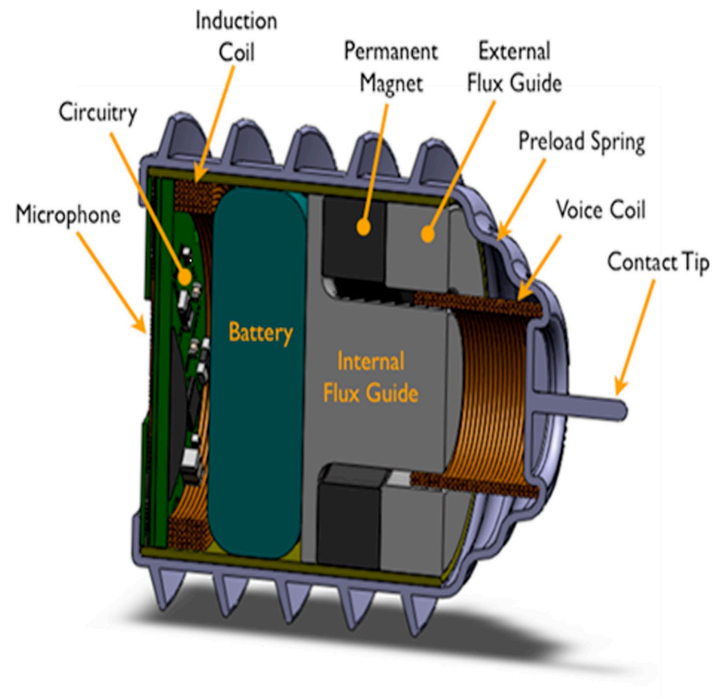

Fig. 7 Device Schematic Design¹⁷

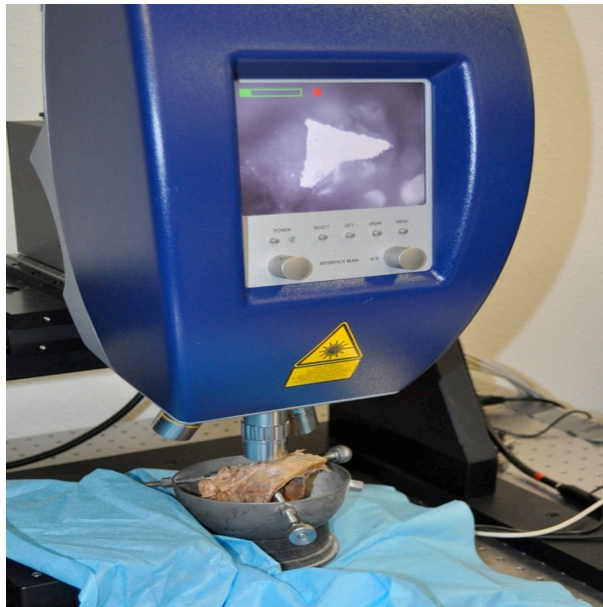

Fig. 8 Laser Doppler¹⁷

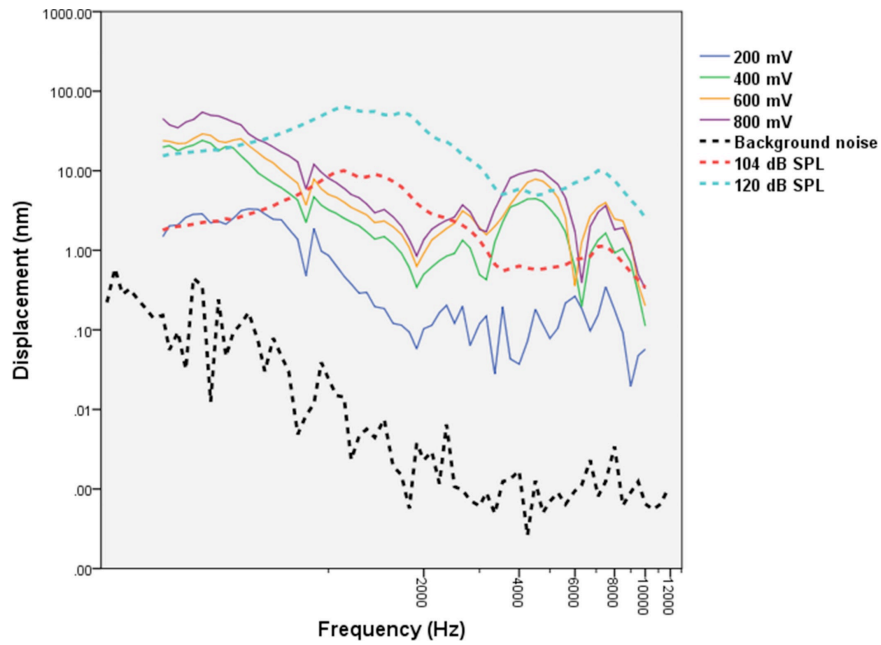

Fig. 9 Frequency Response at Different Voltages¹⁷

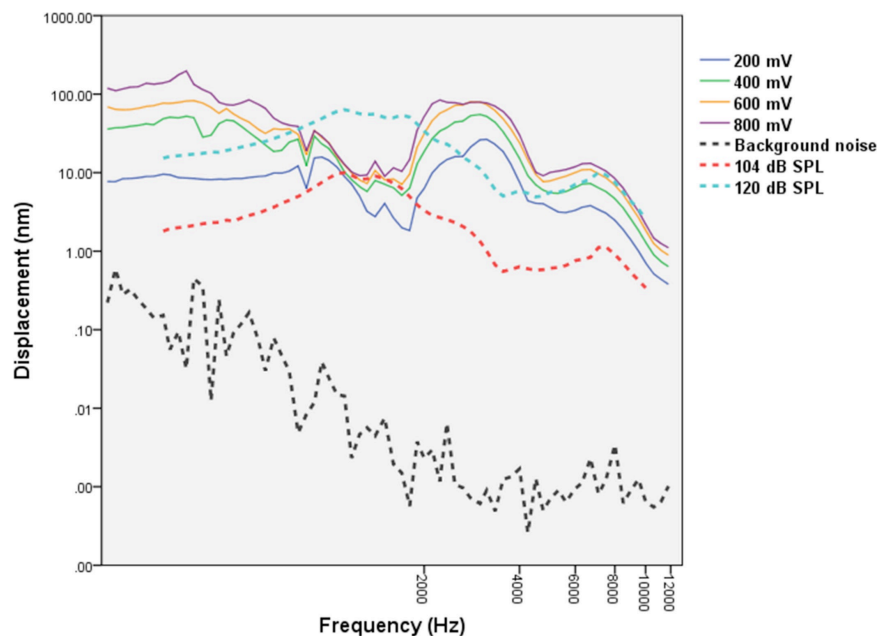

Fig. 10 Comparison of Frequency Response¹⁷

Although most of these studies have not been published within the past five years, the research conducted by Djalilian et al.,¹⁹ Mahboubi et al.,¹⁷ and Paulick et al.¹⁸ can provide insight both in the directions that previous researchers were exploring in terms of the creation of hearing

devices designed to address the same issues that the researcher seeks to correct in the current study, as well as gaining insight into the approaches that were attempted but did not perform as adequately as desired, preventing the current study from going down potential avenues of research that would be ineffective.

Paulick et al¹⁸ sought to create an auditory prosthetic that would combine the use of both conventional hearing aids and middle ear implants. The researchers focused on the creation of the microactuator that would be used to move the tympanic membrane in such a way as to simulate non-aided hearing in adult humans¹⁸. In seeking to complete their research, the researchers started with cadavers to ensure that no living humans would have their hearing further damaged in the completion of their study. The device is shown below.

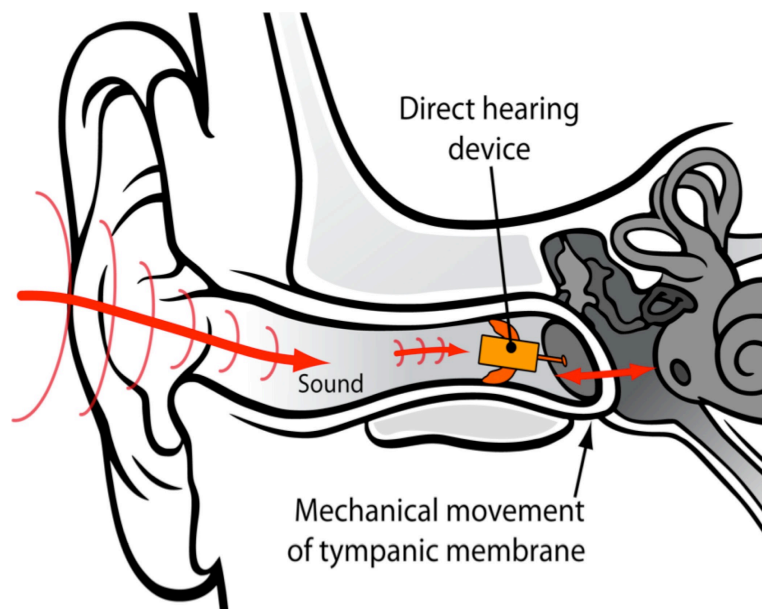

Fig. 11 Placement of Device¹⁸

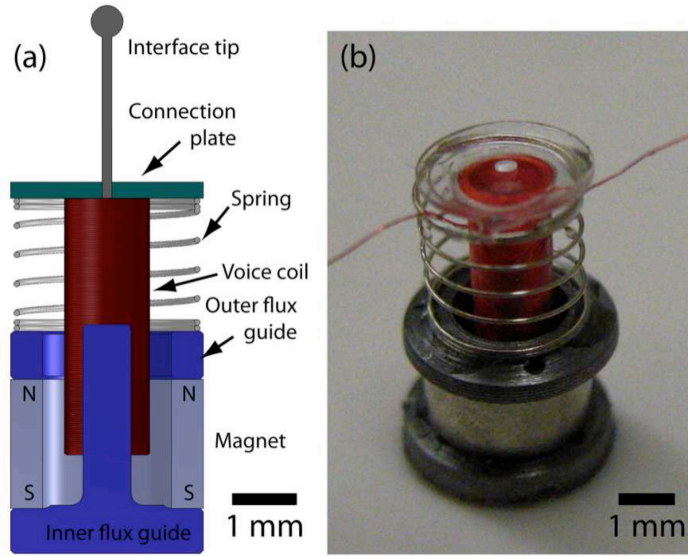

Fig. 12 Dimensions of Device¹⁸

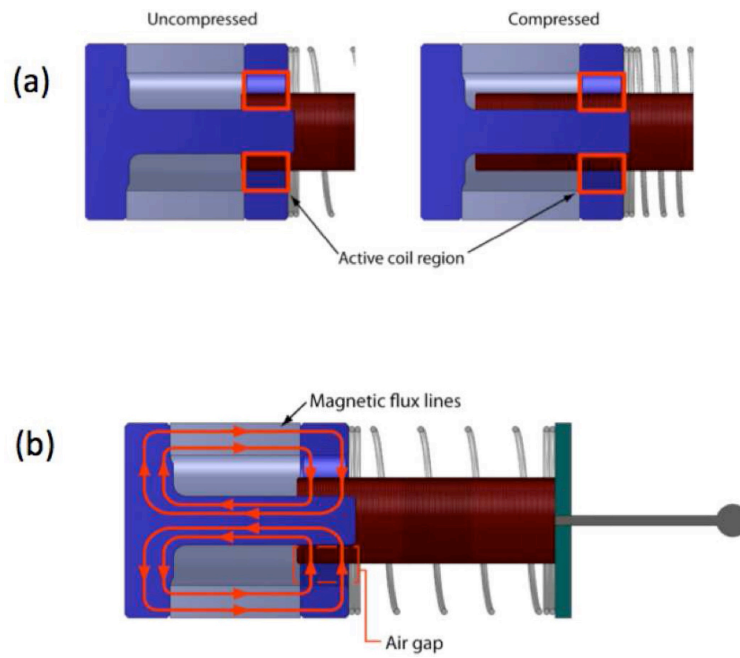

Fig. 13 DHD Cross-section¹⁸

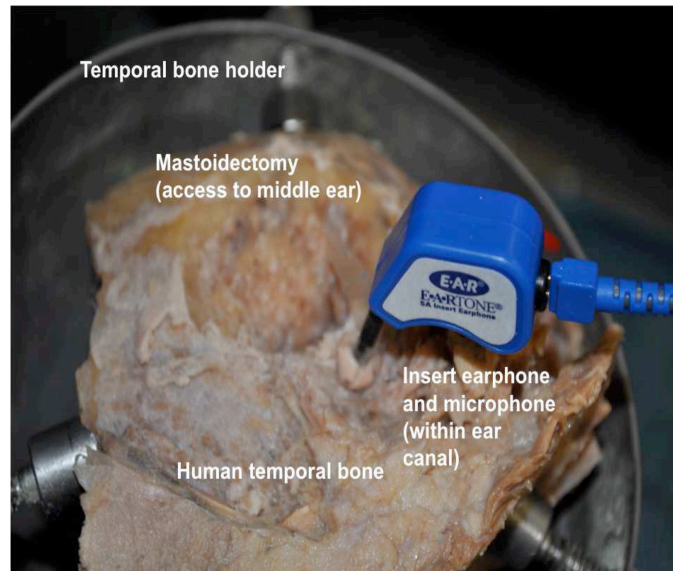

Fig. 14 Implant Surgery Location¹⁸

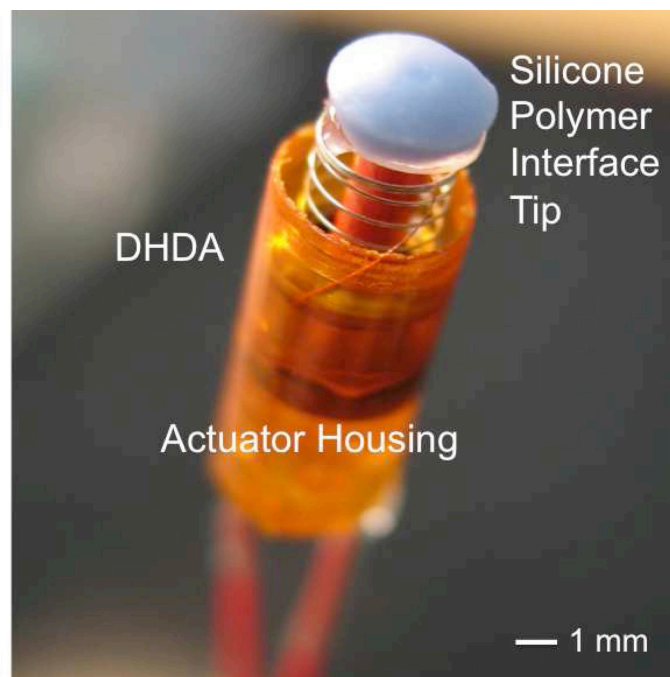

Fig. 15 Close-up of DHD¹⁸

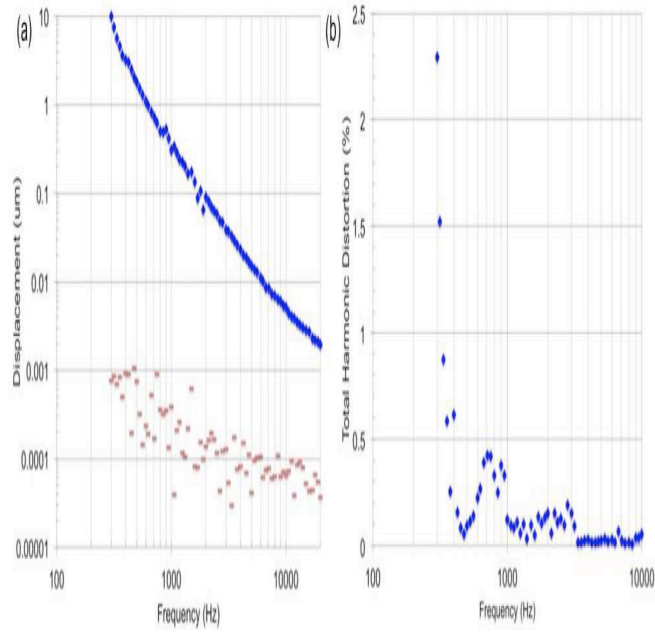

Fig. 16 Coupling Frequency¹⁸

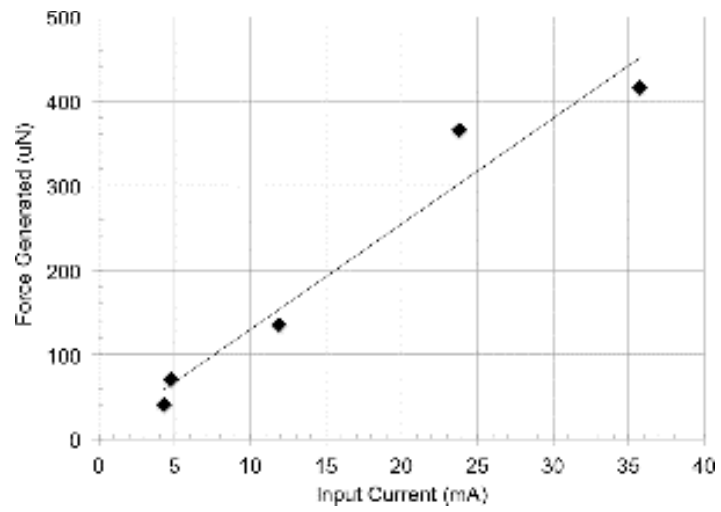

Fig. 17 Force Relationship¹⁸

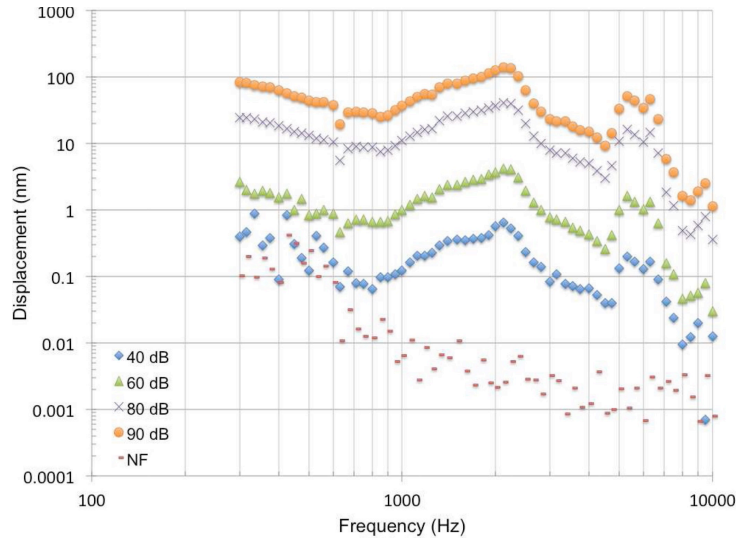

Fig. 18 Middle Ear Frequency Response¹⁸

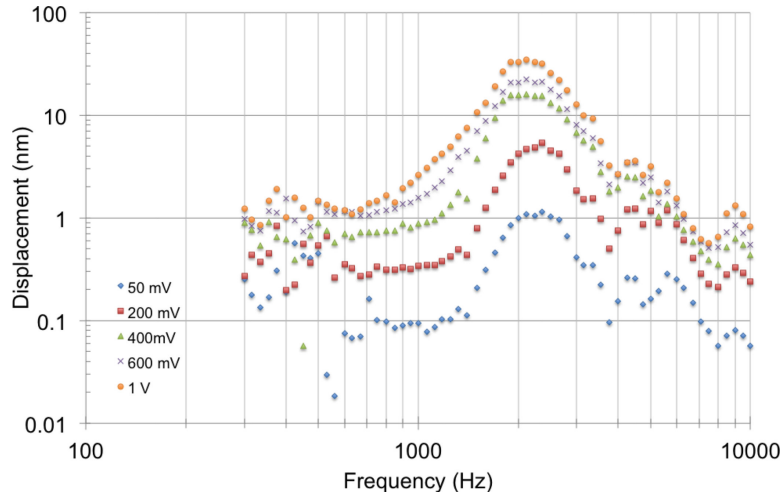

Fig. 19 Tympanic Membrane Coupling¹⁸

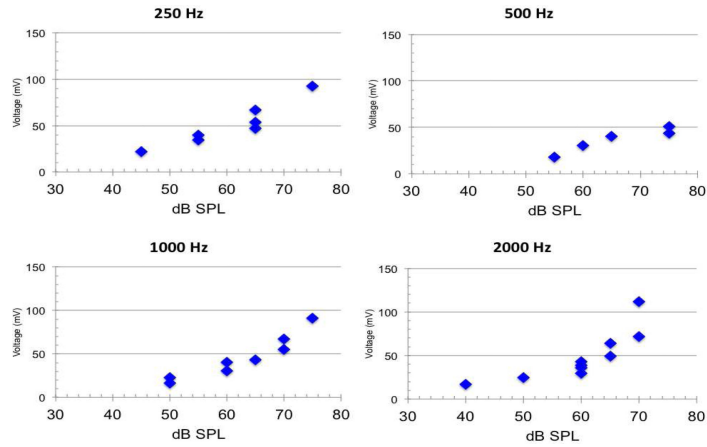

Fig. 20 Frequency of Decibels¹⁸

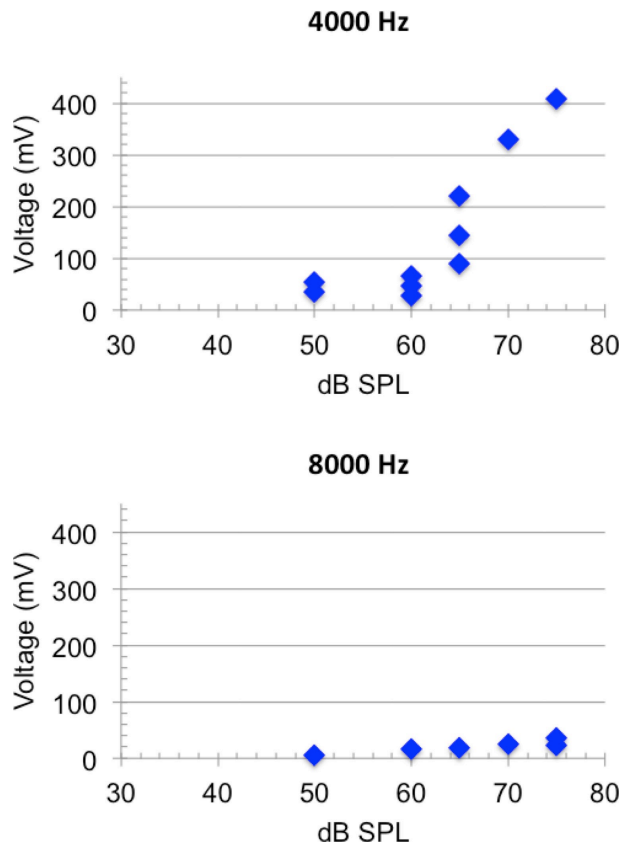

Fig. 21 Pure Tone Stimulation¹⁸

The researchers determined that the activator coil design was most effective at the size of 3.7 mm diameter, and that a varying frequency response was possible in this size with controllable force¹⁸. The researchers found that harmonic distortion for a device this size fell between 425 Hz

and 10kHz and that the coil of this size generated minimal acoustic noise¹⁸. After testing their device on corpses, the researchers validated the effectiveness of the device in short term clinical trials in living humans¹⁸. Paulick et al.'s¹⁸ study provided information on confirmed sizes of actuators and their variation.

Mahboubi et al¹⁷ also conducted a study to facilitate the creation of an auditory prosthetic that would combine the use of both conventional hearing aids and middle ear implants. The researchers sought to explore how the tympanic membrane was influenced in the use of a temporal bone specimen¹⁷. The researchers employed a device that was 3.5 mm in width that would allow it to fit directly into the ear canal without having to rely on a speaker as a means of moving the tympanic membrane¹⁷. The researchers determined, through the use of laser Doppler technology that a device of this size needed a response between 300 Hz and 12kHz, and that the closer the placement to the malleus, the greater amplitude of sound and the lower power requirement for the device¹⁷. The use of a device of this size, combined with the placement locations led to greater frequency outputs, as compared to traditional hearing aid devices¹⁷. Mahboubi et al.'s¹⁷ study provided information on the frequency variation possible for an inserted device of this size and confirmation of its effectiveness within living adult humans.

In Djalilian et al.'s¹⁹ study, the researchers focused on development of a voice coil actuator, building on the previous research conducted by Paulick et al¹⁸ The researchers modified the design in that the actuator would directly drive the tympanic membrane¹⁹. Djalilian et al¹⁹ opted to use a device that was only 3mm in diameter and conducted their study with different contact tips that would touch the tympanic membrane; the point of this was to determine which shape was the most effective while still being better than current auditory devices available on the market. The following figures show the device and findings.

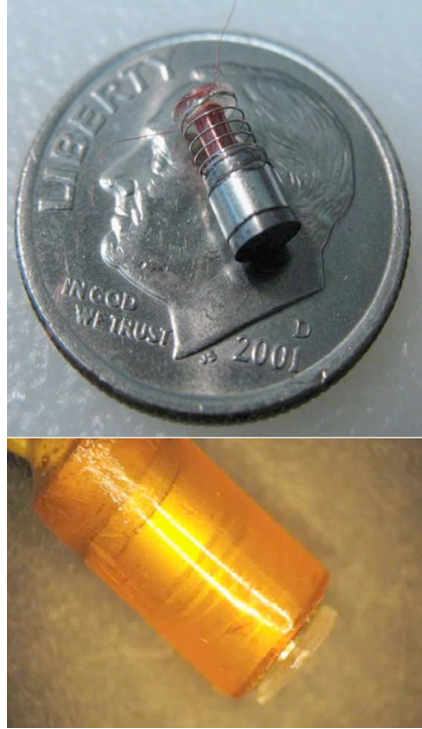

Fig. 22 Device¹⁹



Fig. 23 Creation of Device¹⁹

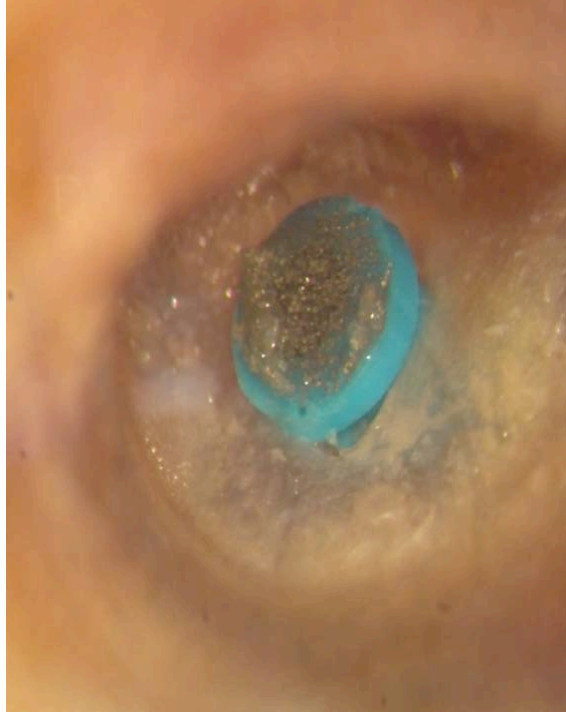

Fig. 24 Magnet in Ear¹⁹



Fig. 25 Insertion of Device¹⁹

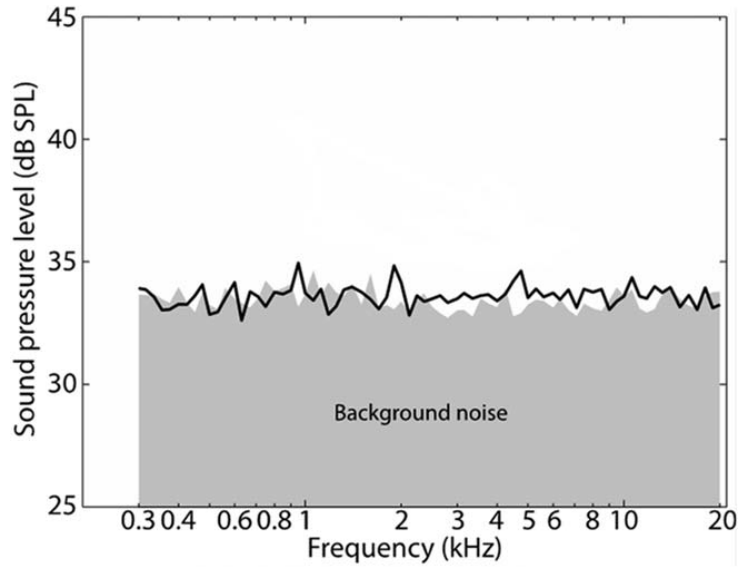

Fig. 26 Frequencies with Background Noise¹⁹

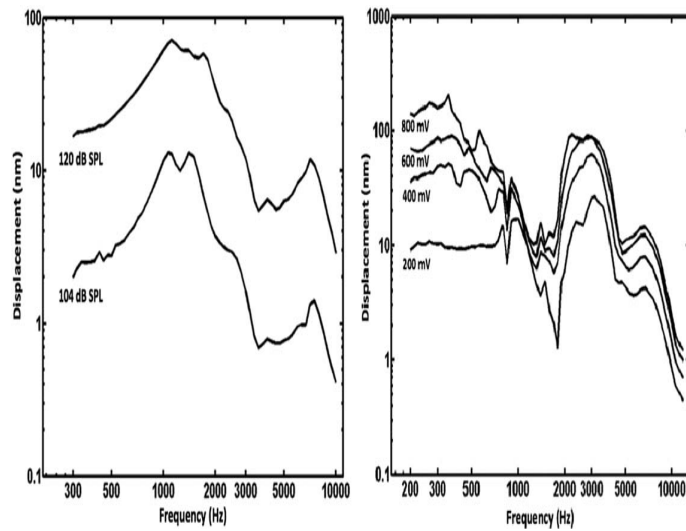

Fig. 27 Frequencies Before and After Implantation¹⁹

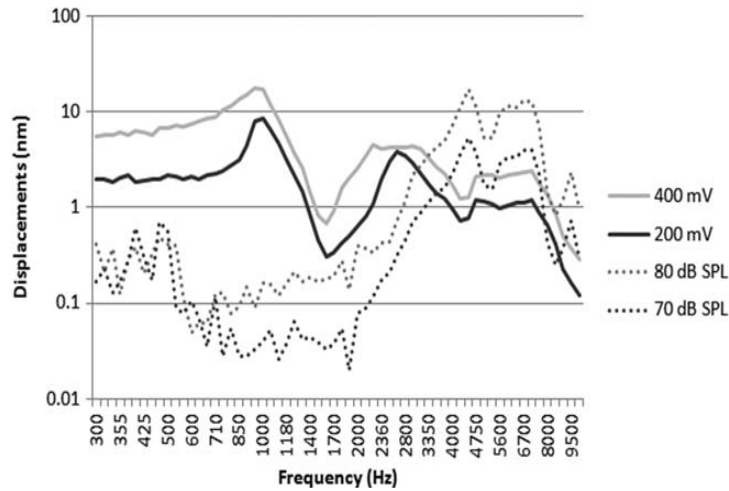

Fig. 28 Differences in Frequencies per Ear¹⁹

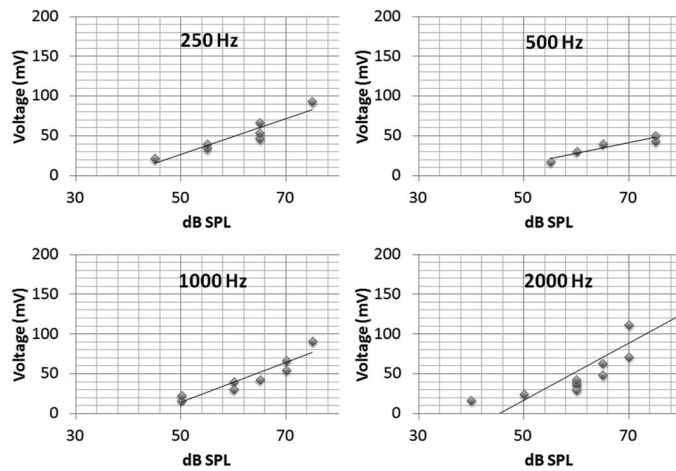

Fig. 29 Difference in Decibels¹⁹

The researchers found that having the temporal bone as the point of contact was better, but that the most efficient approach was to have the point of contact coupled with the malleus, resulting in both wider ranges of sound frequencies and improved amplitude while still using lower levels of power than current traditional hearing aids¹⁹. The devices tested by Djalilian et al¹⁹ were compared to the SoundBridge, a common brand at the time of the study. The researchers noted that while these findings were promising, additional development was needed to ensure that the device could be used both long term and have a wider range of application¹⁹. The findings of

Djalilian et al.'s¹⁹ study offered additional insights that could be used to further these findings in the design of the DHD in the current study.

CHAPTER 1: Hearing Loss and Technology

1. Hearing Loss

Over 10% of the population is affected by hearing loss, one of the most prevalent chronic conditions²⁰. Hearing loss can be caused by sound transduction pathway pathological conditions^{21,22}. The hearing pathway begins at the place where sound pressure waves pass from the external ear to the tympanic membrane. The tympanic membrane also includes the ossicular chain, responsible for converting vibrations into mechanical movements that are then processed by the inner ear²². Within the ossicular chain are the staples, where the footplate couples and transfers the mechanical movements to the window of the cochlea, which contains hair cells²². The role of the hair cells is to sense fluid movement within the cochlea and translate sound characteristics and information into electrical signals, which are passed through the cochlear nerve for processing and interpretation in the higher brain. Hearing loss can be caused by disruption in any element of this pathway²². On the other hand, hearing loss is not frequently caused by brainstem or auditory nerve pathologic conditions²¹. In most cases, the cochlea is involved in hearing loss and, though to a lesser extent, so are the external and middle ear²¹.

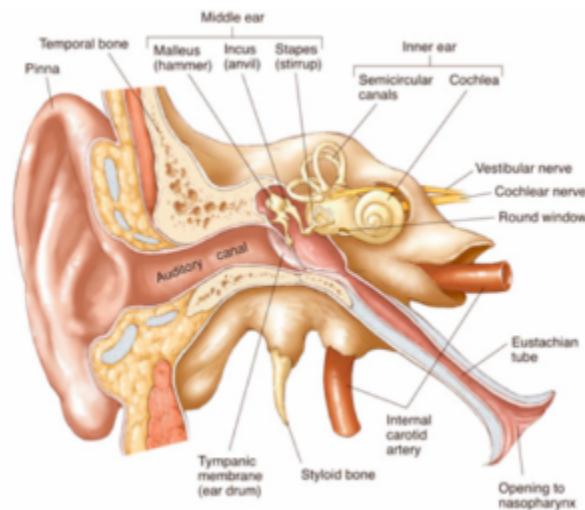

*Fig. 30 Human Ear Anatomy*²³

Hearing loss is considered to be mixed, conductive, or sensorineural. Mixed hearing loss involves elements of conductive and sensorineural hearing loss. Conductive hearing loss involves a change in the external or middle ear, which prevents the cochlea from receiving sound waves. Sensorineural hearing loss is caused by inner ear structures, making it impossible for the nerve impulse to be transmitted to the auditory cortex²².

The most common method to treat hearing loss is through hearing aids, but less than 24% of those needing hearing aids have one²⁴. Reasons for this vary, but include cost, stigma, appearance, and sound quality. Stigma and appearance issues are linked and based on hearing aid visibility and dissatisfaction with sound quality caused by the occlusion effect and feedback²⁴. There must be a compromise in hearing aid designs between these problems. Two common methods for the prevention of feedback involve separating the microphone and speaker, which increases visibility, or ear canal occlusion, which magnifies the occlusion effect. However, the occlusion effect can be offset or reduced through the addition of vents to allow for the escape of sounds trapped in the ear canal²⁵. These types of vents reduce the microphone-speaker attenuation, leading to increased instances of feedback, which leads to a reduction of the amplification level that can be applied. Behind-the-ear (BTE) hearing aids are the only option for those with severe hearing loss.

To address hearing aid-related problems, middle ear implants (MEI) have been developed^{26,27}. With these implants, the ossicles, oval window of the cochlea, or round window of the cochlea are moved using direct mechanical movement. Hearing aids, in comparison, utilize amplified sound pressure, leading the tympanic membrane to move. By directly driving the ossicles, the MEI is a silent operation, leading to the elimination of the occlusion effect and feedback, which leads to improved sound quality^{28,29}. MEIs are promising, but have disadvantages,

such as invasive and irreversible surgery, prohibitive cost, unknown performance until implantation, and surgery for removal. Since both hearing aids and MEIs have shortcomings, there is an increased need for those with moderate to severe hearing loss to have a hearing aid device that has no occlusion, is invisible, and has no invasive surgery.

2. Hearing Technology

Traditional Air Conduction Hearing Aids

Hearing aids are electronic devices that can be worn in or around the ear and amplify environmental sound closer to the tympanic membrane. There are five parts to the hearing aid: microphone, digital processing unit, analog-digital convertor, digital-analog convertor, and speaker. The level of amplification required is based on the level of hearing loss and can be used to treat adults and children³⁰. There are five main hearing aid styles: BTE, mini BTE, in-the-ear (ITE), in-the-canal (ITC), and completely-in-canal (CIC)³¹.

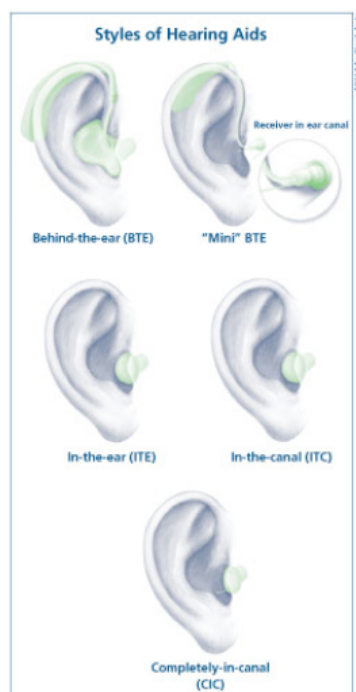
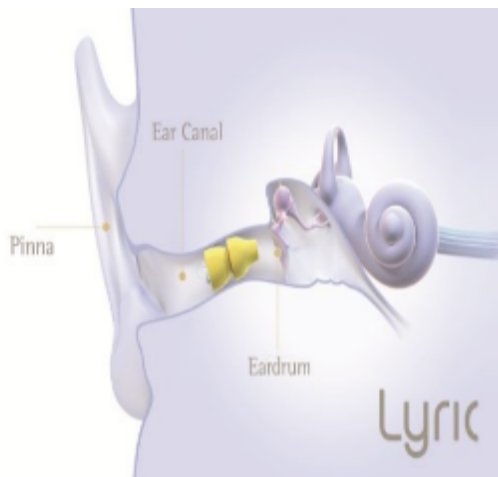

Fig. 31 Types of Hearing Aids³¹

BTEs are mostly used for those with mild to severe hearing loss. CICs are used for those with moderate to severe hearing loss. BTEs are disadvantageous because they are more visible, but are more powerful, have better sound localization, and have less feedback^{31,32}. CICs are less visible, but has a higher cost, is less comfortable, and has a profound occlusion effect³³. Hearing aid costs, regardless of type, can range from several hundred to thousands of dollars for each unit^{33,34} and are not typically covered by health insurance or Medicare. However, there are cases where health insurance covers a portion of the hearing aid^{33,34}. Leading hearing aid companies include ReSound, Oticon, Rexton, Bernafon, and Phonak.



*Fig. 32 Phonak Mini BTE*³⁵



*Fig. 33 Phonak Lyric*³⁶

The Lyric hearing aid was developed to address traditional air conduction hearing aid concerns, focusing on the aesthetics. The Lyric operates using traditional sound amplification, but is not externally visible due to being placed deep within the ear canal by a physician and is not removed for 3 to 4 months and can be worn in water, but is not recommended for swimming or diving³⁰. The Lyric is replaced every 3 to 4 months and has potential feedback issues because of the short microphone-speaker distance, making the Lyric only useful for those with mild to moderately severe hearing loss and do not need much amplification. However, the cost is much higher than traditional hearing aids, which are typically replaced every 5 years³⁰.

Based on a study of Lyric users for the evaluation of comfort and safety, 23% of the participants stopped using the device³⁷. Some participants reported moisture build up, ear canal irritation, ear pain, and occlusion³⁸. The primary issue found in the study regarding Lyric removal was ear canal pain due to unsuitable ear canal geometry. However, for those that did keep the Lyric, the device was preferred by 90% of the participants over their prior device³⁷.

Bone Anchored Hearing Aid (BAHA)

The BAHA is based on the principle of treating hearing loss through bone conduction and involves transmitting environmental sound through the bone to the inner ear. This bypasses the middle ear and ear canal³⁹. The BAHA is most effective for individuals with conductive or mixed hearing loss^{39,40}. The BAHA is used when the traditional hearing aid (discussed in the prior section) is inappropriate, such as in cases of chronic otitis externa, congenital ear canal, narrow ear canal, anatomical abnormalities after mastoid surgery, or one-sided deafness⁴⁰⁻⁴².

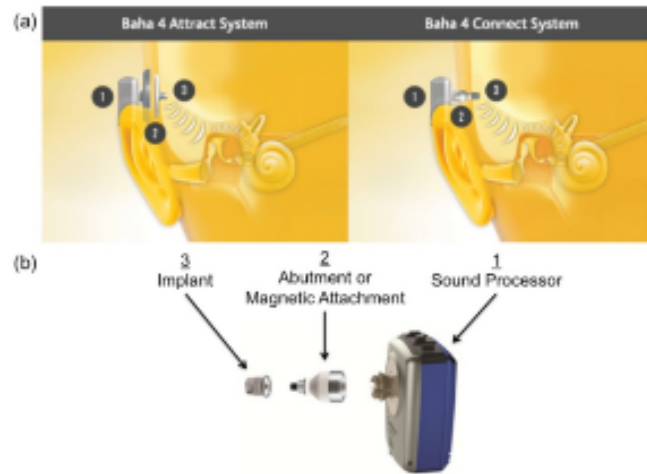

Fig. 34 BAHA⁴³

As seen in the preceding figure, there are 3 components to the BAHA: sound processor, abutment or magnetic attachment, and implant^{41,44,45}. The preceding figure shows two types of BAHA systems. The one on the left has the system with a magnetic attachment, while the one on the right has the system with the abutment attachment, where the implant comes through the skin. The BAHA is made by two primary companies: CochlearTM and Oticon Medical AB. Children typically receive the BAHA under general anesthesia, but adults may receive it under local anesthesia. The procedure takes less than an hour⁴⁰.

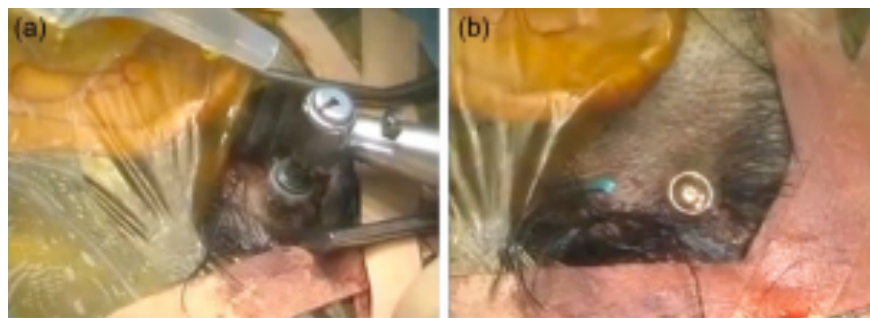

Fig. 35 BAHA Surgical Procedure⁴⁰

The BAHA surgery involves the insertion of the implant into the bone. After healing for about 3 months, the abutment and sound processor are added. The CochlearTM model is slightly different than the Oticon model because the attaching system involves placing a magnet and

implant under the skin, allowing the sound processor to be magnetically attached instead of having the implant be exposed through the skin⁴⁰. The BAHA is advantageous because of the reversibility of the procedure. However, disadvantages include implant failure, larger external prosthesis, surgery, and adverse skin reactions⁴⁶. Despite this, the BAHA is considered to be an effective and reliable option⁴⁶ and offers an effective alternative to the traditional hearing aid^{45,47}.

Cochlear Implants

Cochlear implants work through activating the auditory nerve using electrical stimulation⁴⁸. Normally, sound pressure waves drive the tympanic membrane, ossicular chain, and oval window mechanically, leading to cochlea fluid pressure oscillations⁴⁹. As a result, there is a traveling displacement wave along the cochlea basilar membrane, which divides the cochlear length-wise and has a narrow stiff base and wide flexible apex⁴⁹. A maximum displacement near the cochlea apex is created by lower frequencies, whereas a maximum displacement near the cochlea base is created by higher frequencies, leading to a tonotopically organized cochlea^{49,50}. Hair cells sense the basilar membrane because they are attached in the organ of Corti and operate as mechanotransducers. As a result, they create an electrical spike when deflected⁵⁰. The combined hair cell activation sends information from the auditory nerve to the higher brain for processing and interpretation. In cases of hearing loss, the sensory hair cells can malfunction. As a result, the cochlear implant bypasses the hair cells to directly stimulate the auditory nerve neurons, facilitating sound transmission.

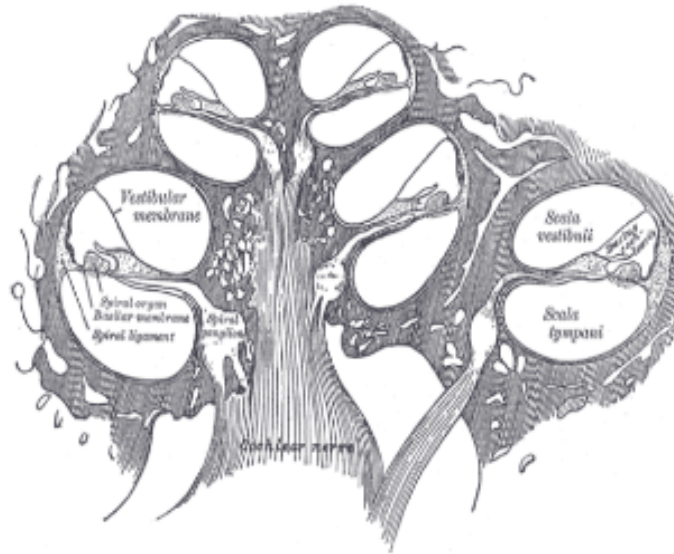

Fig. 36 Cochlea Longitudinal Cross-Section⁵¹

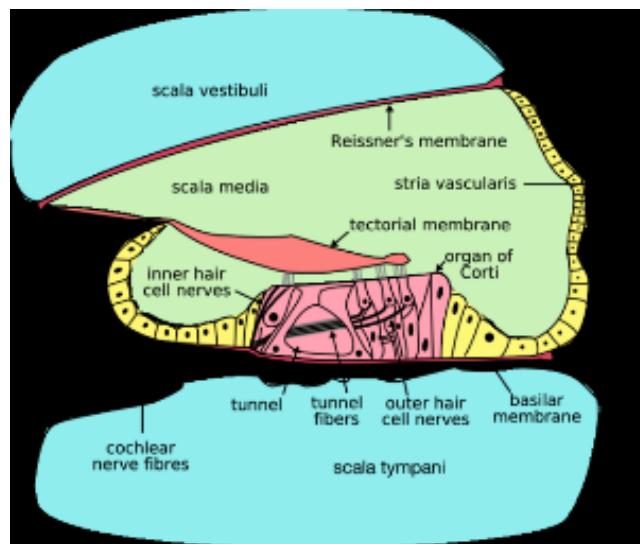

Fig. 37 Cochlea Cross-Section

Cochlear implants are manufactured by 4 companies: CochlearTM, MED-EL GmbH, Advanced Bionics, and, more recently, Oticon⁵². According to the Food and Drug Administration (FDA), in 2012, globally, about 324,200 individuals have a cochlear implant⁵³. Within the United States, there are about 58,000 adults and 38,000 children with a cochlear implant. Typically, the cochlear implant has 5 components: microphone, electrode array, speech processor,

receiver/stimulator, and transmitter⁴⁸. The cochlear implant system works by picking up environmental sound through the microphone and sending the sound to a speech processor behind the ear, which converts it to a digital signal tailored to the type and level of hearing loss being treated. The signal goes to the transmitter, which transmitted coded radio frequencies to the receiver. The transmitter is held in place using a magnet and is coupled to the implanted receiver⁴⁸. The radio frequency signal is received by hermetically sealed electronic circuits within the receiver, which decodes and converts the signal into an electric current, which is then sent to the electrode array implanted in the cochlea. As a result, the auditory nerve is stimulated and the user perceives the current as sound.

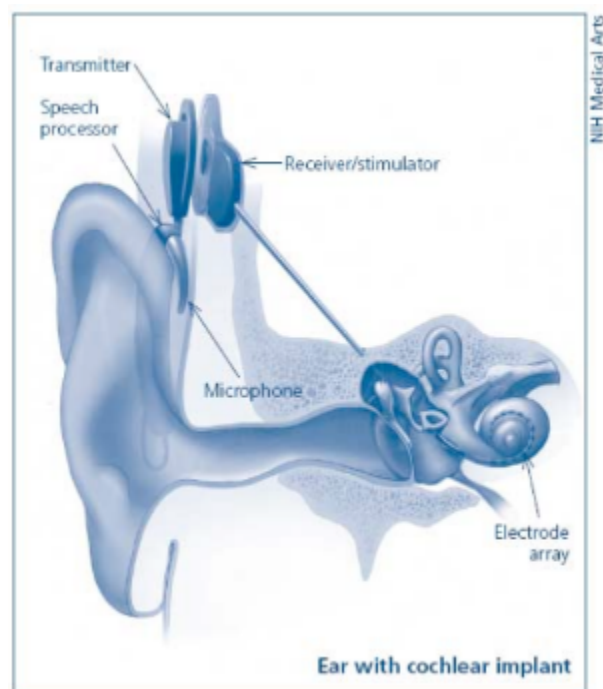

Fig. 38 Cochlear Implant⁵⁴

As of 2010, a cochlear implant (including surgery, adjustments, and training) cost about \$60,000⁵⁵. More recently, health care coverage has improved, where most providers give some type of benefits for the cochlear implant. According to the American Speech-Language-Hearing Association, the coverage increase is caused by improved education and cochlear implant

outcomes. Moreover, it is believed that the American with Disabilities Act, which prohibit insurance company exclusionary practices from alleviating hearing loss⁵⁶.

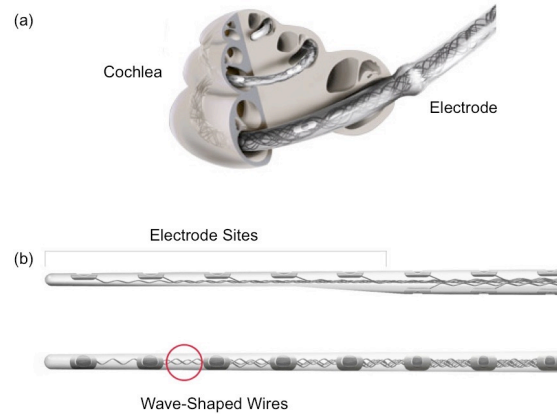

Fig. 39 MED-EL Cochlear Implant Electrode⁵⁷

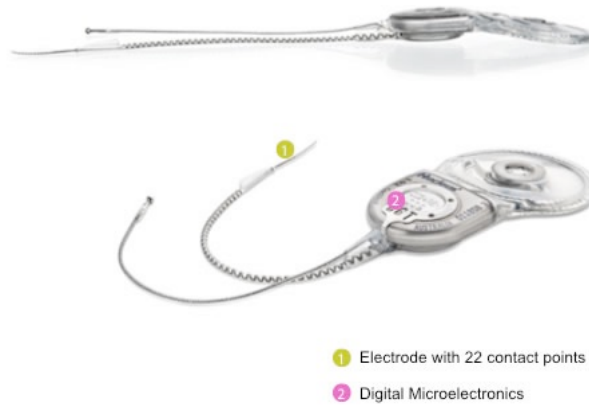

Fig. 40 CochlearTM Hybrid Implant⁵⁸

Middle Ear Implants (MEIs)

Some of the first MEIs were developed in 1935 following the placement of magnets on the tympanic membrane and using a coil in the outer auditory canal to drive them, paving the way for other mechanisms to mechanically drive the middle ear to facilitate the transmission of sound⁵⁹. MEIs were first conceived as being a solution for sensorineural and conductive hearing loss. The

direct-drive stimulation of the middle ear leads to a reduction of traditional hearing aid problems, such as poor acoustics, occlusion, feedback, and ear canal hygiene issues⁶⁰.

Rion Device

The Rion Device was the first piezoelectric semi-implantable device used for conductive and sensorineural hearing loss and was originally developed in 1983 with about 100 Japanese patients being implanted⁶¹. The Rion device has an internal unit and an external unit. The internal unit has a magnetic coil connected by a wire to the ossicular vibrator. The external unit has a battery, microphone, external coil, and amplifier. It is possible to attach the ossicular vibrator to multiple ossicular chain places. The preference is the incus, but it is missing in portions of the chain, it can be a footplate columella. This device worked for some patients for up to 15 years, but most were removed because they became non-functional⁶². This means that the Rion device has decreased efficacy the longer it is worn and, more recently, the device is no longer produced as a result of issues in manufacturing^{63,64}.

Vibrant Soundbridge (VSB)

The VSB is FDA approved and produced by MED-EL GmbH for the treatment of sensorineural hearing loss^{60,65}. The original manufacturer of the VSB device was Symphonix, which was taken over by MED-EL and is the most frequently utilized MEI. It has internal and external components.



Fig. 41 VSB Device⁶⁶

The internal component has the vibrating ossicular prosthesis (VORP), which has a receiver and coil, as well as a processing element that is implanted under the skin and connected to the floating mass transducer (FMT), which is an electromagnetic transducer clipped to the intact ossicular chain incus. The external component consists of the microphone, audio processor, transmitting coil, magnet for coupling the internal and external components, and the battery. Receipt of sound occurs through the external component, which processes and passes it transcutaneously to the internal component. The developed signal mechanically drives the FMT³⁹. The VSB device is a highly reliable implant and there is no deterioration in performance, per studies following patients for 5 to 8 years after implantation^{67,68}. More recently, the use of VSB has been tested for treating mixed hearing loss by positioning the FMT by the round window^{64,69}.

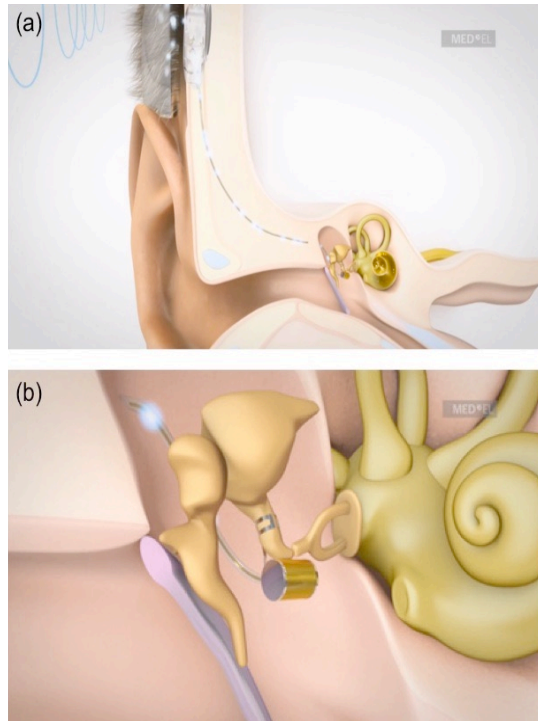

Fig. 42 VBS Animation⁶⁶

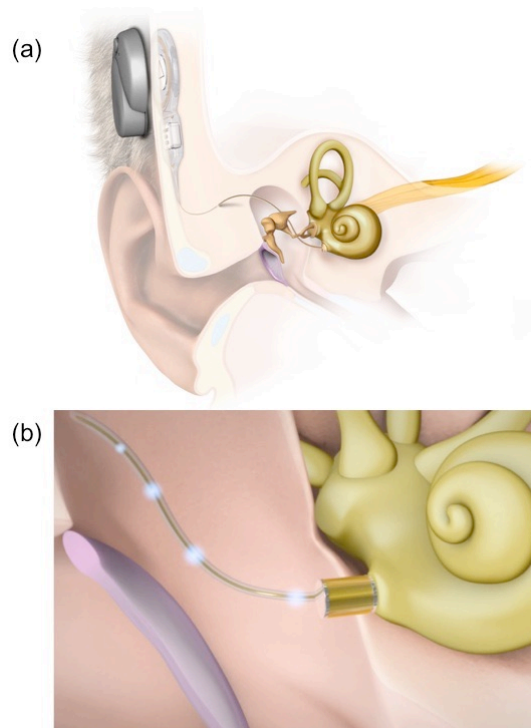

Fig. 43 VBS Placement⁶⁶



Fig. 44Sports Headband to Secure VBS⁶⁶

Soundtec Direct / Ototronix MAXUM Device

The MAXUM was originally manufactured by Soundtech, then acquired by Ototronix. It operates through the use of a neodymium-iron-boron (NdFeB) surgically implanted magnet found on the ossicular chain's incudostapedial joint^{70,71}. The surgical implantation is done under local anesthesia through a tympanoplasty and is much less surgically involved as compared to other MEIs, prompting it to be called a minimally invasive hearing technology that is FDA-approved⁶⁴. The external element (ear mold with an embedded electromagnetic coil) can be placed in the ear canal. The sound processor converts environmental sound to an electrical signal, amplifies it, and sends it to the coil to create an electromagnetic field for driving the implanting magnet⁷⁰. The MAXUM does not have a speaker, so feedback is either reduced or eliminated. The ear canal component does not completely block it, leading to a minimization of occlusion⁷².

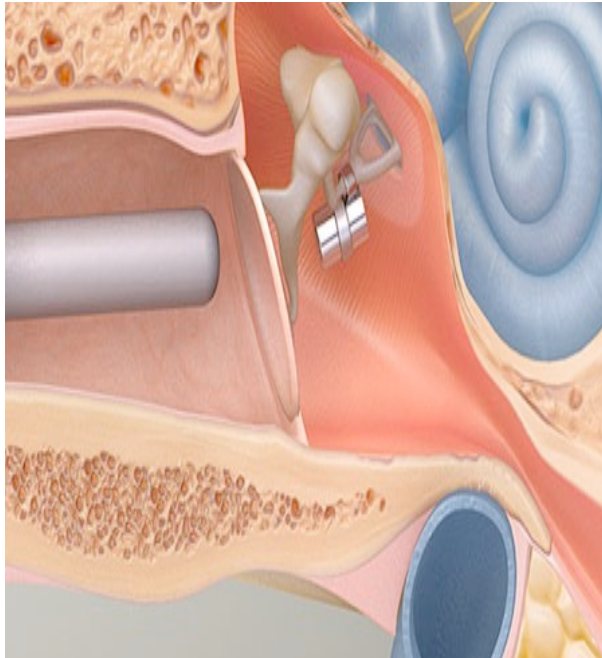

Fig. 45 MAXUM Implant Magnification

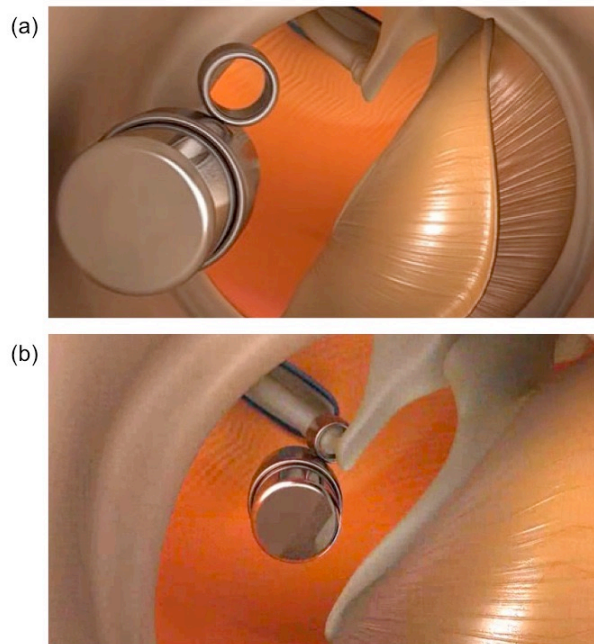

Fig. 46 MAXUM Implantation

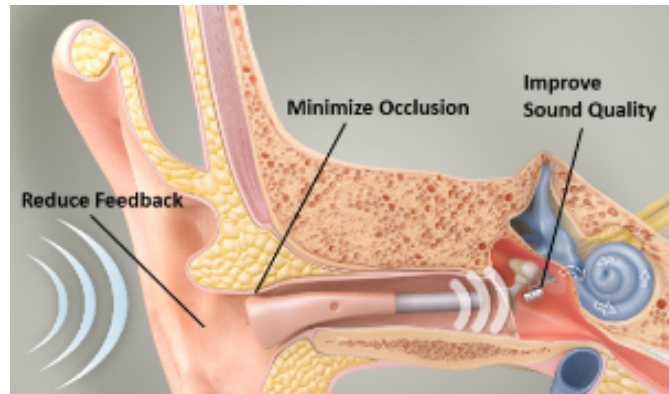

Fig. 47 MAXUM Implant System

Otologics Middle Ear Transducer (MET) Carina® Device

Otologics LLC produces the MET and is seeking approval by the FDA for treating sensorineural and conductive hearing loss, making it beneficial for mixed hearing loss⁷³ with moderate to severe levels^{73,74}. MET is different from other MEIs because it is completely implantable, making it usable while swimming or showering⁶⁴. The MET has an internal amplifier, subcutaneous microphone, and a piezoelectric actuator for driving the incus⁶⁴. The MET is designed to connect to the incus body, but may also be attached to the super structure or footplate of the staples or the round window³⁹. The transducer has reactive power that is absorbed by the implant fixation to the mastoid bone, leading it to have more efficient energy expenditure than other MEIs³⁹. The MET is disadvantageous because of the invasive nature of the surgery and the requirement of surgery for battery replacement about every 5 years.

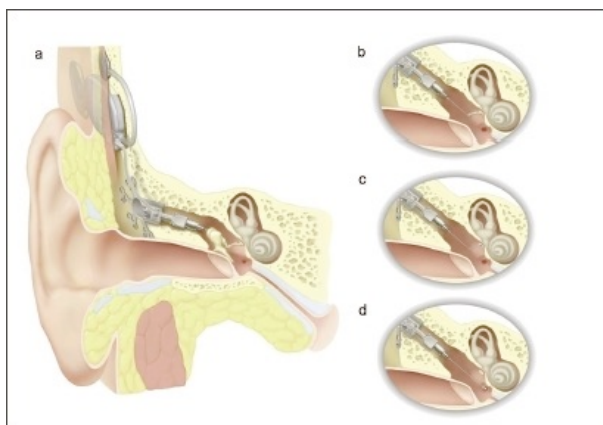

Fig. 48 Carina® Hearing Device

Envoy Esteem

Esteem® was approved by the FDA in March 2010 and is a fully implantable MEI for moderate to severe sensorineural hearing loss in adults. The device functions through a piezoelectric sensory and actuating element that is connected to the implanted battery element in the parietal bed through a reversible surgical procedure⁷⁵.

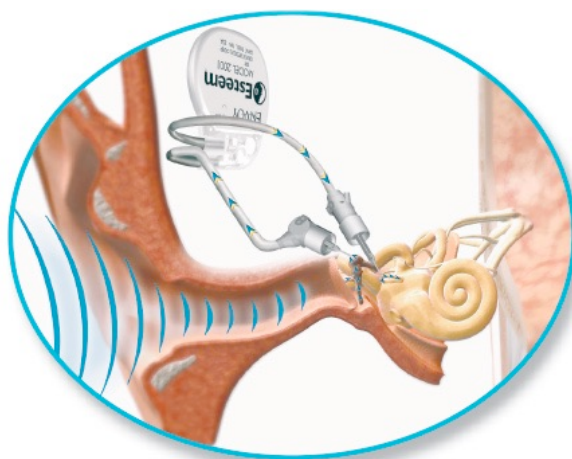

Fig. 49 Envoy Esteem®

The sensing element of the Esteem is coupled to the body of the incus and sensing sound vibrations of the incus, allowing it to act as a microphone. The piezoelectric driver is cemented to the head of the staples, which means that the ossicular chain is severed at long incus process. Vibrations are picked up by the sensor of the incus, filtered, and amplified through the processor,

then transferred to the staples driver. This system is fully implantable and requires surgical replacement of the battery, which lasts from 2.8 to 9 years based on usage⁷⁶. In Phase I trials, patients found the Esteem to lead to increased benefits over traditional hearing aids, such as communication capabilities in high background noise situations⁷⁷. It has been found that the Esteem system has been viewed as being safe and reliable for moderate to severe sensorineural hearing loss⁷⁸.

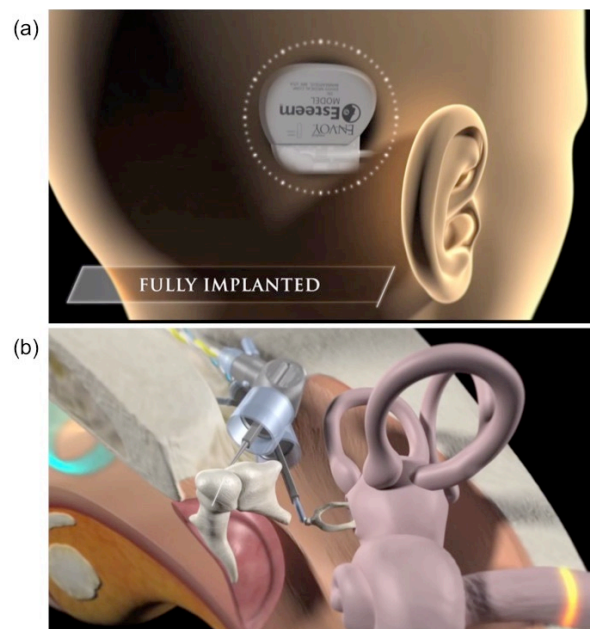

Fig. 50 Envoy Esteem^{®76}

EarLens

EarLens[®] began in 1996 with the formation of the ReSound Corporation then moved to the EarLens[®] Corporation. The original device had 2 elements: magnetic field generation device and transducer⁷⁹. The transducer was a magnet mounted on a platform that was made of silicone and was thin and conical in nature. The lens stayed in place with a drop of mineral oil. The magnet field device was in 2 forms: behind the ear or around the neck. The EarLens device was successful in sound amplification with the two elements without causing tympanic membrane irritation. However, this method was found to be highly inefficient and impractical⁸⁰.

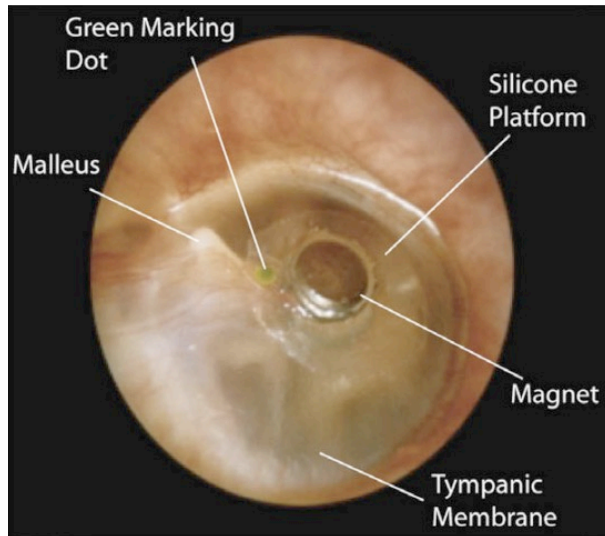

Fig. 51 First EarLens® Transducer System⁸⁰

The next generation of the EarLens was based on the same tympanic membrane lens and embedded magnet concept but used an open-canal hearing device for the driving mechanism. The microphone picks up sound, which is then processed and amplified, then driven through a coil near the tympanic membrane transducer lens. This lens was well-tolerated and stayed in place for participants during a 10-month trial and showed that output could be produced with a threshold of 60 dB HL of hearing impairment⁷⁹.

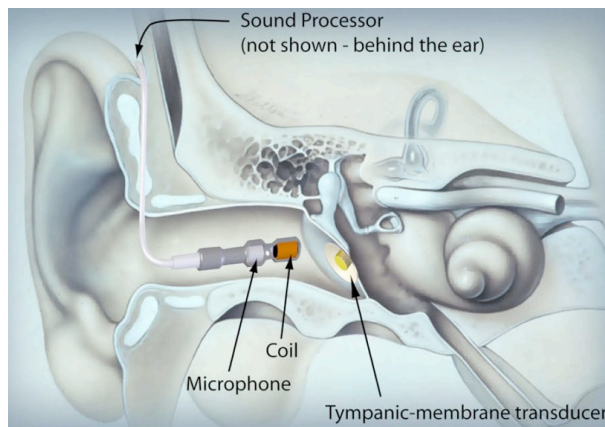

Fig. 52 Second EarLens® Transducer System⁸⁰

The most recent EarLens system uses a photonic energy to transmit signal and power to a microactuator and photodiode located on the EarLens platform⁷⁹.

3. Hearing Aid Use and Performance

Use

With more than 466 million people, globally, experiencing DHL and projected increases in prevalence even before the current global pandemic¹ combined with the potential for a greater than projected increase in the number of people experiencing DHL as a result of changes to the processes used in the operation of the societal fabric brought about as a result of the global pandemic^{3,4}. With the potential for increased hearing loss, in numbers greater than previously anticipated, there is a need to understand the myriad considerations that go into the use of hearing aids by the general public. By understanding the underlying reasons that people utilize hearing aid devices, it becomes possible to gain a deeper insight into the underlying usage considerations that will go into a person's decision regarding whether to use a DHD.

Bisgaard and Ruf⁸¹ sought to identify some of the reasons associated with a person's decision to utilize a hearing aid. The researchers utilized secondary data obtained from the EuroTrak Survey in order to gain insights into hearing aid use⁸¹. Data was self-reported by participants located in a variety of European countries, with no incentivization associated with the provision of this information⁸¹. In reviewing the data obtained from more than 132,000 participants in the EuroTrak Survey, the researchers found that of those, 11,867 participants indicated that they had some form of hearing loss, and of those, only 4,631 indicated that they utilized some form of hearing aid⁸¹. Analysis of the answers from these participants indicated several different factors of consideration went into whether the individual was willing to utilize a hearing assistive device⁸¹.

When exploring only whether the individual was willing to utilize a hearing assistive device, the researchers found that the primary contributing factor was the degree of hearing loss experienced by the potential user⁸¹. The greater the amount of hearing loss experienced, the more

willing the potential user was to consider the use of a hearing assistive device⁸¹. Still further, whether an individual experienced unilateral or bilateral hearing loss also influenced their willingness to utilize a hearing assistive device⁸¹. Those who had bilateral hearing loss were more willing to utilize a hearing assistive device as compared to those who only experienced unilateral hearing loss⁸¹. Furthermore, those who experienced bilateral hearing loss, as compared to those who experienced unilateral hearing loss were not only more willing to use a hearing assistive device, of those who chose to use a hearing assistive device, participants who experienced bilateral hearing loss utilized their hearing assistive device for more hours in a day, as compared to their unilateral hearing loss counterparts⁸¹. Participants with bilateral hearing loss utilized their hearing assistive devices 9.1 hours per day, on average, as compared to those with unilateral hearing loss who utilized the device an average of 7.8 hours per day⁸¹. These findings are in alignment with the researchers' findings that the greater the need, the greater the willingness of the participants to utilize a hearing assistive device⁸¹.

The second consideration self-reported by participants in the EuroTrak Survey regarding willingness to utilize a hearing assistive device was the degree of satisfaction held with the device itself⁸¹. Degree of satisfaction with hearing assistive device was identified by two different categories: the features present in the hearing assistive device and the performance of the device itself⁸¹. The features associated with device use as pertaining to the level of satisfaction held by the users of the assistive devices had less to do with the number of features present and more to do with the perceived usefulness of those features⁸¹. If the device had a high number of features, but users were unable to find the benefit of those features, the device was not rated as highly in satisfaction as the devices with features that were all perceived to be useful by the device users⁸¹. Further, no matter the degree of perceived usefulness associated with the features, if those features

did not have a high level of performance, they were not as satisfactory⁸¹. An additional aspect of consideration when it came to hearing assistive device use was the effect of the degree of utility on the part of the device on the device users' moods⁸¹. The greater the device utility, in terms of its features and its performance, the more improved the mood of the device users⁸¹. Both in comparison between those who rated their hearing assistive devices at higher satisfaction levels to those with lower satisfaction levels and in comparison between those who were willing to use hearing assistive devices to those who were not willing to use hearing assistive devices but who had comparable levels of hearing loss, the researchers determined that those with higher satisfaction and those who were willing to use hearing assistive devices had less instances of depression and lowered instances of cognitive decline as compared to their counterparts⁸¹. This finding suggests that, should users be able to find a hearing assistive device whose features are desirable, functional, and have high performance levels at a reasonable cost to themselves, they will be more likely to utilize a hearing assistive device, and in so doing, will be able to experience quality of life increases.

However, in spite of this potential associated with improvements to the quality of life of an individual who makes the decision to use a hearing assistive device,⁸¹ the majority of research regarding hearing aid use relies upon self-reports, and the majority of these self-reports are not checked against data logged regarding hearing aid use in order to determine the reliability of the collected data⁸². In order to explore the validity of previous studies, Timmer et al⁸² sought to compare self-reported data regarding hearing aid use to data logged by hearing assistive devices in order to estimate the accuracy of previous investigations into this area. In order to accomplish this task, the researchers focused on the amount of use self-reported as compared to the use reported by the participants' hearing assistive devices⁸². The participants had differing degrees of

hearing loss, ranging from mild hearing impairments to moderate hearing impairments; data was transmitted directly from the users' hearing assistive devices to a central server and was then compared with the self-reported use information provided by the participants⁸². Out of a total of 8,489 participants, there was, overall, no statistical difference between the amount of time device use was self-reported and the amount of time that the devices indicated they were in use based on server data, regardless of whether the participants initially were classified as mild hearing loss or moderate hearing loss⁸². These findings indicate that there is a high level of reliability associated with self-reported hearing aid usage data, which offers further support for the use of self-reported hearing assistive device usage data in the design and creation of the prototypes used in the completion of the current study.

Performance

With previous research indicating that performance plays a large role in the willingness of an individual to utilize a hearing assistive device,⁸¹ there is a need to explore the different hearing aid performance considerations that will ideally be taken into account when designing a hearing assistive device. A variety of studies have been conducted, each exploring a different aspect of performance in hearing assistive devices. Identification of these aspects of consideration may assist in the creation of the new design prototype in the current study.

Kates et al⁸³ noted that, for studies conducted by hearing aid designers, the majority of performance metrics are characterized by a set of measurements that are standardized across the industry. While the metrics used by hearing aid designers are not necessarily the same metrics that a hearing aid user will use to determine the perceived performance of the device, an understanding of the standardized measurements used in hearing aid design as they relate to the performance of hearing aids is assistive for the purposes of the design process⁸³. However, in spite of the

beneficence this standardization offers to across the design aspects of the hearing aid creation process, because of the lack of standardization between these metrics and the methods utilized by hearing assistive device users, there is a limit to the beneficence of these metrics⁸³. In order to work to address these concerns, Kates et al⁸³ sought to create a set of metrics that would, utilizing the standardized metrics within the industry, provide a means for designers to predict the performance of hearing assistive devices as perceived by the users of those devices. The researchers created two different tools, the HASPI to measure the intelligibility of the devices and the HASQI to measure the speech quality of the devices⁸³. While the researchers did not test the effectiveness of these two tools against commercially available devices in order to determine the accuracy of the tools that were created, they did seek to explore the feasibility of using these two tools against commercially available hearing aids while simultaneously working to indicate the value of the tools and to determine whether there were any potential issues in applicability of the tools⁸³. The researchers found that the combination of the two tools could be used to predict the overall performance level of a particular device, however, if the tools were used separately, there was a decreased likelihood that the performance of the device could be anticipated, as it was the combination of the two scores that served as the indicator⁸³. Ultimately, the researchers could not determine a degree of clinical significance associated with the use of the tools as a predictor of overall device success, and as a result, indicated that further refinement of the tools, and additional data collection, would be needed⁸³. The findings of this particular study highlight the difficulties associated with determining the predictive success of a particular device and highlight the continued need for self-reported testing of prototypes. The human component is essential in determining the overarching performance of the device and the perceived level of beneficence associated with the device itself.

An additional hearing aid performance consideration noted within the extant body of literature, was the desire for reduced listening effort associated with new hearing assistive devices⁸⁴. The older the listening device, the older the technology that was used to create the listening device; further, the older the device, the more likely that technology is in need of updating⁸⁴. As a result, the older the technology, and the more in need of updating the technology is within the assistive device, the more concentration is required on the part of the assistive device user in order to parse or process the information that is conveyed through the assistive hearing device⁸⁴. The greater the concentration required in order to process the information delivered to the user via the assistive hearing device, the less concentration that the user has for other activities⁸⁴. This leads to decreased satisfaction with the device itself, which can in turn decrease the willingness of the user to utilize the device. As a result, there is a need to ensure that the new technologies incorporated into hearing assistive devices are focused on improved processing abilities, leading to decreased listening effort on the part of the assistive device user⁸⁴. This translates to a need for improved tone recognition, a focus on adaptive directional receiving, and ensuring a narrow directionality, decreasing the need of the individual to parse out other background sounds and information that may be coming in more clearly than the conversation the user is attempting to participate in or the sounds that are the primary focus of the user's attention⁸⁴. The device, in order to be considered of high performance quality, must allow the user to maintain their desired sound quality, convey sounds at an appropriate loudness, offer listening comfort to the user, and enable the user to optimize their understanding of speech, regardless of the degree of background noise present within the listening environment⁸⁴. These aspects of consideration are only recently being taken into account when designing listening assistive devices, in spite of the need for these aspects to be present in order to normalize the hearing process as much as possible

for those who experience hearing loss⁸⁴ At this time, the only way to test and adjust these aspects of consideration in the hearing design process is to create a prototype and then obtain feedback from users within a clinical trial environment, adjusting these components as necessary⁸⁴. Current efforts in these areas of research show that there is still a great deal of research that must be done in these areas in order to reduce the listening effort on the part of the user, as even the newest commercially available devices still require approximately 50% of the user's listening effort. There is a need to reduce the amount of listening effort needed as close to zero as possible⁸⁴.

Yet, the process of reducing listening effort is not as simple as mere device modification¹⁶. de Souza et al¹⁶ suggest that, based on their findings, it is not enough to create hearing assistive devices that are tailored toward a generalized reduction of listening effort. According to their research, the researchers indicate that it is both important that the hearing assistive device is created with these aspects in mind, but there is also the need to be able to tailor the devices to the specific needs of the individual when the individual is fitted for a hearing assistive device¹⁶. The researchers identified several key areas that must be taken into account if the listening effort is to be decreased on the part of the user; these included the degree to which the individual had lost their hearing, the age of the individual, the cognitive capabilities of the individual in terms of their level of working memory or processing power available, and their ability to respond to the signals given off by the hearing aid itself¹⁶. If any of these factors were overlooked, the effectiveness of the device would decrease for the user, thereby decreasing its perceived performance level and the user's associated willingness to utilize the device¹⁶. To this end, the researchers suggested that there was a need not only to test hearing assistive devices within a clinical environment, but to obtain feedback from users after they had been used within a real world environment for set periods of time¹⁶. Without the collection of this information, the researchers suggested, no matter how effective the devices

were shown to be in clinical trials, the ratings of the users regarding those technologies would show that the performances of those devices would be less effective because they would be less effective for personal use¹⁶. To this end, the researchers wished to understand the role that each of these individual factors played in understanding how much effort listeners had to exert in order to process the signals received through their hearing aids¹⁶. As the researchers believed that the greatest amount of effort would be expended based on age as the predominant factor, the researchers conducted their study with older adults, those between the ages of 54 and 90 years old at the time of data collection¹⁶. The researchers found that there was a wide range of responses associated with each of the participants based on a double blind study in which neither the researchers nor the participants knew which aspects were being explored in device modification¹⁶. The findings of the study showed that listening exertion depended first on the age of the individual, second on their mental capacity, and third on the degree of hearing loss¹⁶. The signal processing ability of the user decreased with age, suggesting the need for greater degrees of device modification the older the device user¹⁶. The findings from this study suggest that, in the creation of a new hearing assistive device, there is a need to take these different aspects of hearing aid use into consideration, factoring in the need for adjustments as the user gets older, much the same way that a vision prescription will change over time.

In addition to taking into account the degree of hearing effort required in terms of the age of the individual, the mental capacity of the individual, and the degree of hearing loss experienced by the individual,¹⁶ there is an additional consideration that must be taken into account when exploring the degree of listening exertion put forth by the individual: the environmental noises present within the listening area⁸⁵. The environmental noises present within a given listening area will vary in strength and intensity depending on the location of the individual within the listening

environment, the acoustics of the listening environment, the amount of additional sounds present within the listening environment, and other similar considerations⁸⁵. Current technology requires the hearing assistive device user to make manual adjustments in order to achieve the best quality of sound and the easiest comprehension of speech within a given environment, however, for many hearing assistive device users, this part of the technology can be cumbersome, tedious, or frustrating⁸⁵. In light of these considerations, Tchorz et al⁸⁵ suggested that there was a need to create classifications for different types of environmental sounds commonly found in the average listening environment. Utilization of this type of classification system would enable the hearing assistive device creator in creating a series of preprogrammed settings through the use of amplitude modulation spectrogram features allowing for the replication of sound pathways within the listening environment⁸⁵. By incorporating these aspects of the listening environment as pre-programmable features, not only would there be the potential for increased ease of use as associated with different listening devices, there would be the potential to increase the overall accuracy of the hearing device for the user, thereby increasing the perceived performance of the device⁸⁵. As past research suggests, the better the performance of the device, the greater the willingness of the user to utilize the device, and the better quality of life experienced by the user.

In addition to exploring the option of creating pre-programmed settings for the user,⁸⁵ some researchers have taken the configuration of hearing assistive devices a step further⁸⁶. The majority of technology users in the developed world are familiar with smart technologies, with *smart* serving as an acronym for *Self-Monitoring, Analysis, and Reporting Technologies*, and indeed, a great many available technologies are making the transition to smart technologies, allowing users to engage in remote access, metric tracking, modifications over distance, and so forth⁸⁶. There is a certain segment of researchers within the hearing assistive device technologies field of research

that is focused on the integration of smart technologies within the hearing assistive device market⁸⁶. Nossier et al⁸⁶ is one such group of researchers. The researchers believe that it will be possible to integrate the neural networks of the hearing assistive device users with the hearing assistive device technologies in order to create linkages between the brain of the hearing assistive device user and the technology, bypassing the components of the ear while still allowing access to a secondary alert based system that would use the neural responses of the individual to enhance or detract certain noise patterns from the stream of consciousness of the individual in order to increase the overall ability of the user to hear noises that the user deems important⁸⁶. While such a focus has potential positive applications for hearing assistive device users, this type of technological advancement comes with its own host of problems, including those associated with the current hearing assistive device technology in the areas of cognitive processing, age related working memory changes, and so forth. For younger users with hearing loss, such a technology may eventually prove fruitful, however, for the general population of those who require the use of hearing assistive technologies, the linkage of the user's neural net with their hearing assistive device has a decreased likelihood of success, based on the findings of previously discussed researchers. There is a need to continue to work to refine and develop current hearing assistive device technologies and address the issues present in the current use of these technologies, technologies that can be used by all ages and all cognitive abilities, before working to create a new biotechnology that may come with a higher price tag even still, depending on how the neural net linkages are made.

Johnson et al⁸⁷ recognized the need to address the linkages to the effectiveness of the hearing assistive device in the activities of daily living conducted by the hearing assistive device user. The researchers have completed a series of studies focusing on the different components of

activities of daily life that are impacted by the use of hearing assistive technologies⁸⁷. The researchers address not only the needs of users in the completion of their activities of daily living, but the differences between the performance of average hearing assistive devices and high end assistive hearing devices currently available on the market⁸⁷. Within this particular study in the series, the researchers were focused on the localization of sound, the need for localization of sound in hearing tasks, and the exploration of how different currently available devices performed in sound localization, as rated by hearing assistive device users⁸⁷. The first test conducted by the researchers was to determine whether localization of sound was better or worse between the high end devices and the average devices currently available on the market⁸⁷. The researchers utilized a participant sample pool of 45 adults, men and women, with an average age of 70.3 years old⁸⁷. In order to determine the effectiveness over time of each of the devices, participants were asked to utilize four different devices, each over a four week period of time⁸⁷. Following a four week period of use to ensure that the participants were comfortable with using each particular device, the participants were brought into a sound treated room to test the localization of sound effectiveness for each of the devices⁸⁷. Tests were done consecutively, meaning that the participants wore the first device for four weeks, tested, wore the next device for four weeks, tested, and so forth until all four devices were recorded⁸⁷. The results showed that there was no discernable difference between the high end devices and the average devices in terms of localization of sound⁸⁷.

Since there was no difference between the high end and average devices in localization of sound, the researchers next wished to determine whether there was any difference in localization of sound between device use and no device use⁸⁷. The results showed that there was no statistically significant difference in the localization of sound with a device or without a device⁸⁷. This means that the users could not tell sound localization regardless of whether a hearing assistive device was

present, indicating that currently available technology, even the more advanced technology commercially available, does not assist users in pinpointing the location from which sound originates⁸⁷. This lack of ability to differentiate sound localization regardless of the use of an assistive device was identified as an area of issue with current hearing assistive device technologies that needed to be addressed and corrected in future design efforts⁸⁷.

Minimum Requirements

Due to the wide range in research and design efforts regarding hearing aids and the rising prevalence of hearing loss at a global level, the World Health Organization (WHO) put together a list of the minimum criteria necessary for all hearing assistive devices⁸⁸. This list was intended to dictate the types and features that should be present in hearing assistive technology, regardless of country in which the individual operated, in order to ensure that the requirements for corrective hearing could be met at costs that could be met by the general population of a country, regardless of the developed or developing status of the country⁸⁸. The WHO classified the types and features into two separate categories, those that are considered essential for the user and those that are viewed as desirable for the user⁸⁸. Under the classification of types of hearing aids, the WHO states that the hearing aid must have several essential components, including comfort, ease of wear, must incorporate digital technologies, should be behind the ear devices, should be performance verified through testing with the individual user, should be amplified according to the user's prescription, and should have a robust design⁸⁸. Comfort and ease of use are considered essential components to ensure that the device does not cause skin agitation or irritation in order to increase the likelihood of use and secure fit⁸⁸. Digital technology components are considered essential because of the greater signal processing power, as compared to analog technologies, ensuring the widest range of addressing hearing loss⁸⁸. The behind the ear hearing aid type is considered essential because it

has the lowest potential for malfunction as compared to all hearing aid types, and the performance adjustments must be made, tailoring the device to the user, to ensure maximum benefit⁸⁸. The hearing aid should be prescription based to the individual to ensure the maximum benefit to the user, and the design must be robust to prevent breakage, as the user may have limited access to repair capabilities⁸⁸. Finally, in terms of the hearing aid types that are considered desirable, the WHO indicates that the software should be open source to increase the ease of compatibility across multiple devices⁸⁸.

The WHO next addressed the different features of the hearing aids that should be present, again, dividing these components into the essential components and the desirable features⁸⁸. The first essential feature of hearing aids is identified as compression; the reason for this is several fold⁸⁸. First, compression works to reduce the range of sounds present within the listening environment, making it easier for the user to parse the listening experience while at the same time decreasing the potential that an inadvertent sound within the listening environment could become falsely amplified, resulting in greater hearing loss than was already present⁸⁸. Second, by ensuring that the hearing aid has compression as a feature, this increases the comfort level of the wearer, which in turn increases the likelihood of use, and therefore the potential for the device to fulfill its designated function⁸⁸. The second essential feature is the management of feedback⁸⁸. By ensuring the presence of feedback management, this increases the quality of the hearing aid, the ease of listening experience, and decreases the potential for additional damage to the user's hearing⁸⁸. Additional required features include an on-off switch to conserve battery and facilitate device use and volume controls so that the user can adjust their own listening experience⁸⁸.

When it comes to the desirable features for the hearing aid to include, the list is much longer, including the adaptive reduction of noise, the presence of a telecoil facility, resistance to

climate elements, direct audio input capabilities, and a low battery alert function⁸⁸. Adaptive noise reduction works to contribute to ease of use, decreasing the need for the constant volume adjustment on the part of the user⁸⁸. Climate resistance refers to the ability of the hearing aid to withstand changes in climate including increased or lowered heat, increased or lowered humidity, and some form of coating to aid in water repelling in the event of rain or other weather events that could lead to the damage of the hearing assistive device⁸⁸. The presence of a copper telecoil is intended to allow the user to detect electromagnetic induction signals, allowing the user to effectively operate a telephone or cell phone, thereby allowing the user to bypass the hearing aid microphone and increase ease of activities of daily living⁸⁸. Direct audio input refers to the option for the user to directly connect a piece of audio equipment to the hearing aid, including, but not limited to, telephones, cell phones, mp3 players, televisions, microphones, and radios⁸⁸. This ensures maximum flexibility both within the classroom environment and in the office environment⁸⁸. Finally, the low battery alert will be used to alert the user to loss of function, decline in hearing related to the battery, and provide an indication of the need to charge, which will prevent the battery from deteriorating as quickly, thereby increasing the potential for longevity of the device⁸⁸.

The final areas documented by the WHO for minimum requirements for hearing assistive devices are in the area of device cost, labeling, packaging, ear molding, and repair⁸⁸. As with the other components, this too is divided between essential considerations and desired considerations⁸⁸. The essential cost considerations are identified as being affordable, while the desired consideration is listed as providing the financial support that may be necessary for hearing assistive device users to ensure that all users are able to gain access to needed technology regardless of cost of technology⁸⁸. In terms of labeling, only an essential component is listed,

namely, that all hearing aids should be marked with the manufacturer, the model number, the serial number, and the year of manufacture, along with instructions on battery placement to prevent improper installation⁸⁸. In the area of packaging, only essential elements are listed as well, namely that the packaging must be robust, to prevent damage to the device; that it must contain all technical specifications associated with the hearing assistive device enclosed; that any contraindications associated with device use must be clearly stated on the package; and the package must contain a user guide⁸⁸.

When it comes to the power supply, there are both essential and desirable features listed⁸⁸. The essential features include that the batteries that the hearing aid uses must be readily available in the given region in which the user will utilize the device, and that all packaging for power supply associated components must be safe and clearly labeled with requisite safety instructions⁸⁸. The desirable components include being rust resistant, to offer some form of rechargeable power functionality, either in the form of rechargeable batteries or other form of recharging capabilities, and that the power source for the device should not include mercury due to the potential health problems associated with its presence⁸⁸.

Ear molding is likewise designated by essential and desirable components⁸⁸. The essential aspects of ear molding are that they are appropriate both to the type of hearing aid with which the user is being fitted and to the user themselves, with different possible options ranging from stock to custom ear molds suggested⁸⁸. Desirable considerations consist of offering different types disposable ear molds, allowing for increased comfort on the part of the user⁸⁸.

The final area of consideration dictated by the WHO is repair⁸⁸. Essential hearing aid repair should include the ability to repair the housing of the components of the hearing assistive device, both to ensure the ability to maintain the device and to ensure that the user is able to adjust the

device as needed without having the potential of damaging internal components⁸⁸. In addition, it is considered essential that a post-fit service is offered in which any malfunctions or issues the user should experience can be addressed with a minimum capability of providing device cleaning, replacement of ear hooks, battery contact adjustments, the ability to change out switches, the ability to change out trimmers, and the ability to change out, adjust, or modify volume controls⁸⁸. It is considered desirable that a post-fit service be offered to users in order to ensure ease of adjustment and repair⁸⁸.

CHAPTER 2: Direct Hearing Device (DHD)

The problem this study seeks to explore is the design and creation of a new hearing aid device that still has all of the benefits of current hearing aid technologies while simultaneously working to reduce the associated detriments with preexisting hearing aid technology. With current advancements in hearing aid technology focused on the inclusion of artificial intelligence (AI) elements, as opposed to addressing the main underlying problems that prevent users from either getting or utilizing their current hearing aid devices,^{14,15} there is a need to address the problem in between these extremes. Ultimately, the problem lies in between the two extremes: while advancement of hearing aid technology is important, and while AI and other technological advancements do have the potential to capitulate the hearing technology field into areas not previously possible, these efforts fail to take into account the initial problems of design, comfort, ease of use, and, perhaps most importantly for many, cost, that prevent users from accessing or utilizing the preexisting technologies in the first place^{12,14}. There is a need to address these baseline concerns before looking to explore more advanced options that will likewise be cost prohibitive for users.

The purpose of the current study was to design a new hearing aid prosthesis that would address the previously identified problems with both current hearing aid technologies and implantable device technologies while simultaneously maintaining the advantages present with current common use hearing aid and implantable device technologies. Goals included ensuring that the created device would fit comfortably and with ease, have minimal maintenance requirements, prevent issues commonly associated with hearing aid technologies (feedback, the occlusion effect, sound distortion, sound quality, inability to reduce background noises, ongoing maintenance needs, concerns regarding the physical fit of the device, and even difficulties

associated with hearing aid handling), without the problems associated with surgery and performance associated with implantable devices while still being cost effective for the average individual who requires hearing assistive technologies to address some form of hearing loss.

The significance of the study is several fold. First, the current study and the product of the current study seek to address limitations identified within current hearing aid technologies; by negating use concerns and cost concerns, the product created as a result of the current study should, if commercially produced, result in an increase in the number of individuals who both have access to and who are willing to utilize a hearing device^{14,15}. Secondly, in light of the projected rising prevalence of hearing loss at the global level through 2050¹. the availability of clear, easy to use, low cost hearing aid technologies will provide hearing support for the millions of people who are just starting to experience the symptoms of hearing loss or will experience hearing loss, in addition to those who have already lost their hearing. The creation of this device, if adopted for commercial production, will lead to the potential for improved, or at least not declining, cognitive function due to hearing loss, decreases in loss of productivity, and overall improvements to quality of life for those who have experienced hearing loss¹³

Prior to starting a research study, it is important for the researcher to identify the assumptions, limitations, and delimitations that are present at the outset. While additional assumptions may be identified as the study progresses, and while the researcher may identify further limitations as the study progresses, it is still important to identify those that are present at the outset in the interest of the reliability and validity of the study⁸⁹. Identification of the delimitations of the study at the outset of the study works to increase the transparency present within the study itself⁸⁹.

The assumptions of the study are defined as the aspects of a study that are generally accepted as true or the ideas under which the researcher is operating as if they were true⁸⁹. Certain assumptions were present at the start of the current study. It was assumed that it would be possible to work with the information compiled by past researchers in order to continue to refine the design of an effective DHD. It was further assumed that, in light of the previous research in this area having been published in peer reviewed journals that the information contained within those articles and the conclusion made by the researchers, including the calculations presented within those studies, would be both true and accurate. In light of this assumption, it was also assumed that the researchers would be able to start from the point of information presented in those studies and be able to create a working prototype based on the information contained therein. It was further assumed that modifications to the design information presented in prior research found within the extant body of literature could be modified in such a way as to lead to improvements in both the design and operation of the device.

The limitations of a study identify the ways in which the completion of the study may be limited; these can include both the flaws and the shortcomings that may be present in the completion of a particular study⁸⁹. The first limitation identified prior to starting the study was that, even if a device design were completed and a prototype generated, the information collected regarding the comfort associated with ease of use would only be measured in the short term. No long-term use over time information would be able to be collected through the completion of the study. As a result, while information may be provided by the participants during the clinical trial, further research would be needed to study the effectiveness over time. A second limitation associated with the completion of the current study stems from a delimitation of the study to a particular geographic region; however, as a result of this delimitation, this means that the findings

of the study may be specific to that particular climate, and more so, may be particular to that particular climate at the time the results were collected. This means that the findings of the study may not be generalizable to a different season or a different location as variations in temperature, air pressure, barometric pressure, and other weather conditions may have the potential to impact the collected results. In light of this limitation, further research would also be needed, assuming the successful design of the device, the successful creation of the prototype, and the effectiveness of the prototype within the clinical trial.

The delimitations of the study are the characteristics of the study that are set by the researcher to specifically limit the scope of the study; they aid the researcher in setting boundaries for the study allowing for effective study completion⁸⁹. Delimitations for the current study included the use of a small sample size, as a means of decreasing the potential for exposure on the part of participants and the researcher in light of the current pandemic, the decision to collect data from participants during a single session for the same reason, and the decision to conduct an experimental study, combining the design and testing of the prototype in the completion of a single study. These delimitations were made in light of the current global pandemic and the need to ensure accuracy in data collection while simultaneously taking into consideration the current state of the world.

1. Direct Hearing Device

Several primary design requirements were present in the creation of the DHD prototype. The device had to be designed with moderate to severe hearing loss in mind, it had to be optimized for the most effective delivery of sound, be cost effective, invisible, and remove any requirements typically associated with surgical implantation for this type of solution. Utilizing information on previously created direct hearing devices as a starting point, including identification of

components, operation, and frequencies, these figures were compared against the areas in which current users of hearing assistive devices experienced issues, difficulties, or complaints. This provided the researcher with a starting point in the design of the DHD. Utilizing this information, the researcher started to design the prototype.

2. Design and Prototype

The DHD prototype consists of four primary elements: 1) the tympanic membrane/ malleus driver, 2) a microphone, 3) a signal processor, and 4) a power system. The malleus driver is the voice coil actuator and it consists of two sets of permanent magnets attached to diaphragms, a voice coil, and a detachable tip. The focus of this design was to create a design that could be classified as commercially ready for production.

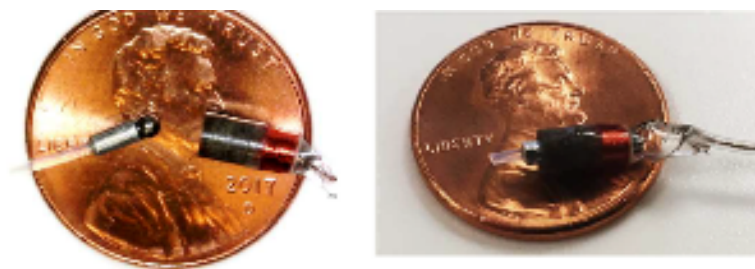

New DHD actuator with detachable tip

Fig. 53 DHD Actuator with Detachable Tip

With the design in mind, the next step was to determine whether the new design was feasible. In order to accomplish this task, a prototype of the design was created and the researcher sought to analyze the difference in frequency responses in both a strong coupling and a weak coupling setup. The key difference between the two testing setups was the existence of a 500 micron gap between the magnets of the weak coupling and no apparent gap present between the magnets of the strong coupling. Both sets of magnets contain a diaphragm between them, a membrane like layer used to separate the magnets in each pairing.

Cup test set up:

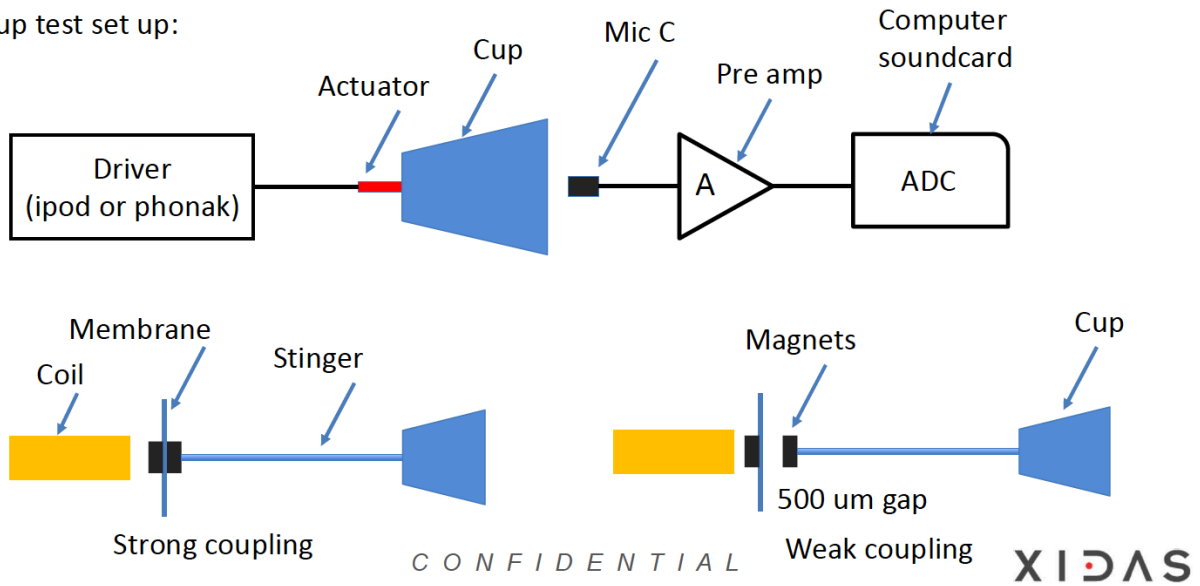

Fig. 54 Coupling Mockups for Testing

Following the completion of the first test, a second test was setup to determine the feasibility of the design. The second test consisted of multiple trials, each with a stinger of a different length. Using 0 microns as the reference point, the microphone c membrane was tested at -400 microns with an iPod driver, -400 microns with a Phonak hearing aid driver, at 0 microns with an iPod driver, and at +400 microns with an iPod driver. The (+) represents a decrease in the length to the left, while the (-) represents an increase in the length to the right. Each of these tests were intended to be simulations that would allow the researcher to obtain and graph out the frequency responses of the DHD tip actuator. A cup was used to imitate the tympanic membrane, and a preamp was used to amplify the obtained sound.

Cup test set up:

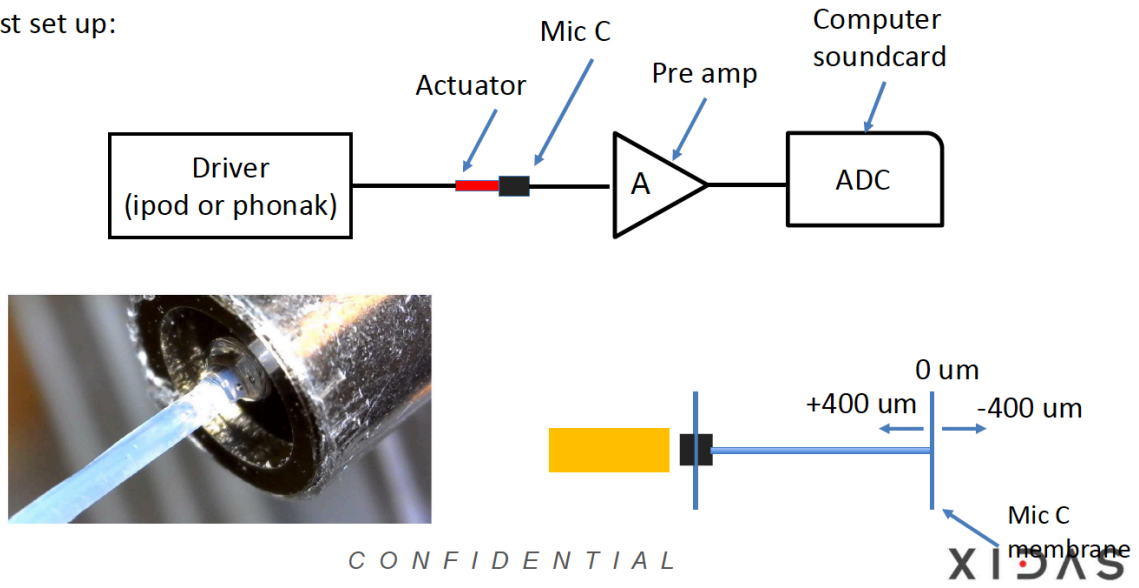

Fig. 55 Cup Test

In this paper, a new design for a DHD device was developed, which provided more mounting options for physicians and allowed for more contact between the arm of the device and the tympanic membrane. This device underwent experiments to determine its frequency response. The initial testing setup consists of the driver (either being an iPod or Phonak) being connected to an actuator and the shorter end of a paper cup. The larger end of the paper cup is then connected to a Mic C, pre-amp, and computer sound card. In the initial setup, the pre-amp gain of the device plateaued to about 39 dB. After setting up, the frequency responses for strong and weak couplings were measured. For testing the strong coupling, there is a coil, and some distance away are two magnets (separated only by a thin membrane) connected to a stinger, which is attached to the shorter end of the cup. For the weak coupling setup, the coil is separated from the magnets. Instead of the magnets being only separated by a thin membrane, there is a 500um gap between the magnet and membrane closest to the wire, and the magnet directly attached to the stinger and cup. The frequency response of the weak coupling after applying adjustments for pre-amp gain was much smoother than the strong coupling's response and experienced less changes in dB over varying

frequencies. To test the frequency response of the Mic C, a similar setup was used. A driver was connected to an actuator-Mic C combination, which itself was attached to a pre-amp and computer sound card. The Mic C moved 400 μm to the left and right of its original position. There was the highest, most stable frequency range when Mic C was located 400 μm from the left of its original position. This device was also tested in a clinical trial to determine its stability and comfort for a user when he is performing daily actions, as well as when the device is being indeed or removed from the subject's ear canal. The results of the clinical trial are that the subject was comfortable and had normal sound quality and volume during most of the daily-life situations, except when eating, sitting-up very fast, wallowing, or holding a burp. Also, the subject felt discomfort, along with varying sound quality and volume when the device was either being inserted or removed from the ear canal.

Cup test
set up:



Fig. 56 Cup Test Setup

The results obtained from the design testing of the device are presented in the next chapter, prior to the results obtained from the clinical trial regarding the effectiveness of the design. The test setup shown below presents a diagram of the frequency test setup.

Test set up:

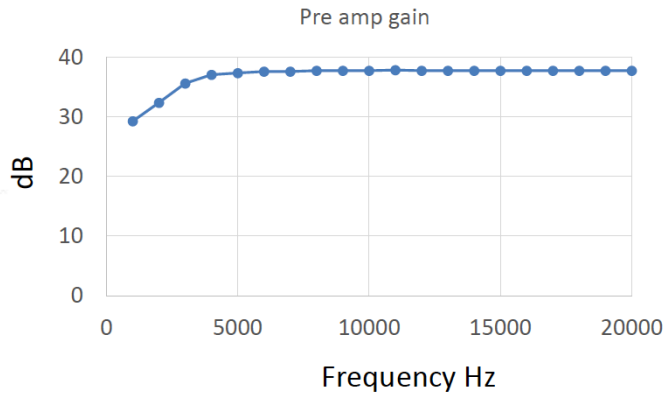
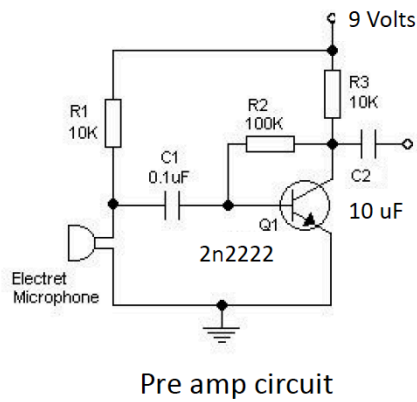

Fig. 57 Frequency Testing

Prior to starting the clinical trial, however, there was also a need to ensure that the DHD prototype would work effectively with the human body. To this end, the DHD prototype was inserted into an artificial model of the outer ear canal to ensure that the device would fit and rest properly.

Actuator fittings:

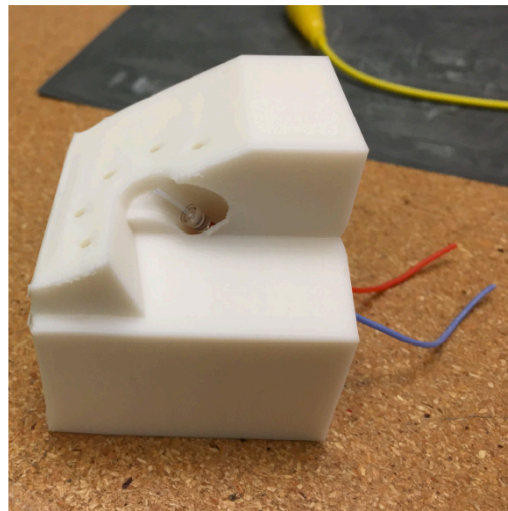
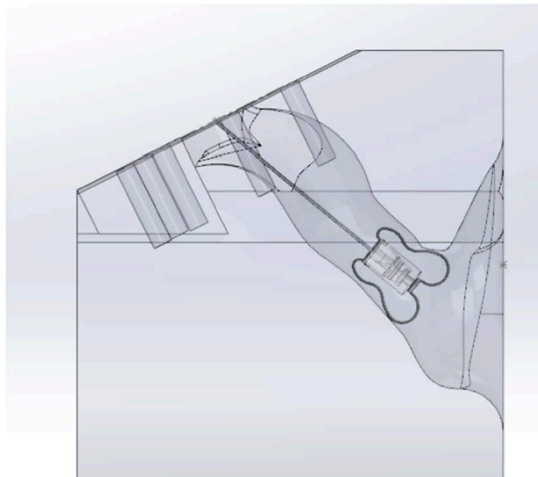

Fig. 58 Artificial Ear Testing

After testing the DHD prototype and determining the best construction for the device, the next step was to conduct a clinical test with human participants in order to determine whether the DHD would rest comfortably in a patient's ear and to ensure that the device would work

appropriately in an ear. No matter how well a prototype responds during non-human testing, this does not mean that the test results will replicate when paired with the human body. As a result, the clinical trial was a necessity to ensure that the DHD would maintain the same levels of effectiveness during the completion of various daily activities including sitting, sitting up, walking, climbing stairs, and consuming food.

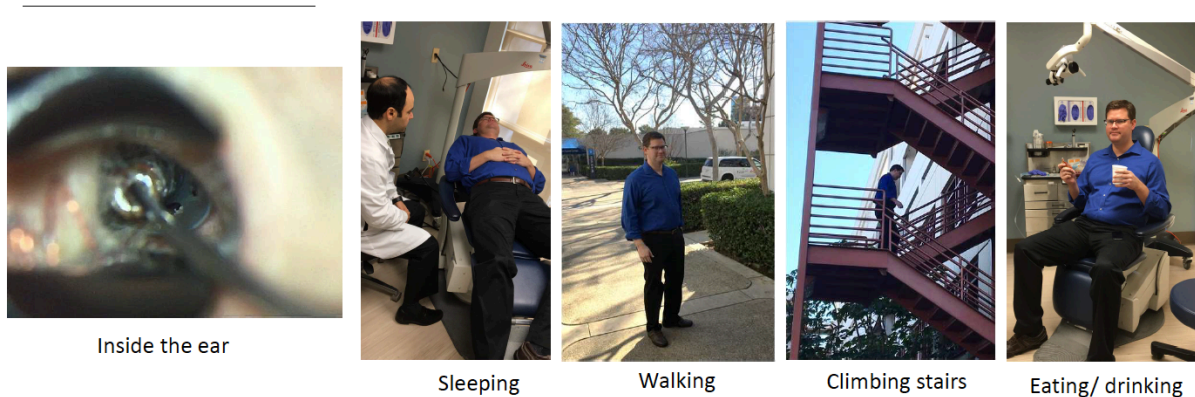

Fig. 59 Clinical Trial – Stability

The participant was fitted with the DHD prototype in a clinical setting and was requested to perform specific functions while utilizing the device. The participant was then asked to provide ratings associated with the comfort of the positioning of the device while completing tasks and were asked to provide ratings on sound volume and sound quality while completing these tasks. This information was recorded and compared against current commercially available devices.

3. Frequency Response

From the DHD presentation, there is simulation testing on a paper cup to test the frequency response of the device. Assuming that this paper cup was used to simulate the tympanic membrane in the surface where the actuator makes contact. This pulse from the actuator is picked up by the microphone on the inside of the cup to see the amplitude gain of the device utilizing the pre-amp to convert the weak pulse into an output signal strong enough to limit noise. The main parameter

tested was the coupling (strong/weak) where the magnet placement either further or directly connected to the membrane corresponded to the strong and weak coupling, respectively. The frequency response of the high-pass filter preamp was tested with a 9-volt battery. This was used as a baseline for testing the strong/weak coupling. The results seem to show a steady decibel level across the frequency range for the weak coupling, but the strong coupling has a downward slope of decibel gain over increasing frequency. I was a little confused on the driver and the +400 micrometer to -400 micrometer test using an iPod or Phonak, but the results show a much more consistent decibel gain for -400 microns iPod than the rest of the microphones. There was also a clinical trial of a patient wearing the device for the device probably utilizing the Phonak dome as the anchoring mechanism. The results were seemingly positive where the comfortability, sound volume, and sound quality were mostly good across a multitude of situations.

4. Total Harmonic Distortion and Noise

A new design was conceptualized that is intended to improve upon currently available inside-the-ear hearing aids. A few of the changes implemented include a decrease in size, an increase in manufacturability, a decrease in production cost, and an improvement in mechanical coupling. In order to experimentally test the feasibility of this idea, three different test methods were conducted. The objective of the first test was to analyze the difference between a strong coupling and a weak coupling setup. The key difference between both setups is the existence of a 500 micron gap present between the magnets of the weak coupling, and no apparent gap between the magnets of the strong coupling. Both sets of magnets contained a membrane-like layer between them. The second test consisted of multiple trials, each involving a stinger of a different length. With a reference point of 0 microns, the Mic C membrane was tested at -400 microns with an iPod driver and then again with a Phonak hearing aid driver, 0 microns with an iPod driver, and +400

microns with an iPod driver. The (+) represents a decrease in length to the left, and the (-) represents an increase in length to the right. Both of these tests were simulations created in order to obtain and graph out the frequency response of the DHD tip actuator. A cup was used to imitate the tympanic membrane, and a preamp was used to amplify the obtained sound. The final test was a clinical trial conducted to determine whether the DHD would rest comfortably and work properly inside of a patient. When the DHD was inserted into the patient, instances of various daily activities such as sitting, sitting up, walking, climbing stairs, and consuming food were recorded, among others. Before this trial was done, the DHD was inserted into an artificial model of the outer ear canal to determine if the device would fit and rest properly.

The first test yielded a graph displaying the decibel level versus the frequency for both the strong coupling and the weak coupling trials. Based on these frequency response graphs, it appears the weak coupling setup yields more accurate results. The strong coupling seems to pick up on more background noise and displays a more variable result, while the weak coupling seems to be more focused and less sensitive to unwanted noises, overall simulating normal hearing more accurately. The strong coupling also induced a steep decline in decibels around 19kHz. The second test yielded a frequency response graph comparing stinger lengths of -400 microns with an iPod driver, -400 microns with a Phonak hearing aid driver, 0 microns with an iPod driver, and +400 microns with an iPod driver. It is apparent that the -400 microns with the iPod driver yields the most consistent and accurate results, and it is important to note that the Phonak driver seemed to give the least accurate results, displaying a large decline in decibels around 8kHz. The clinical trial produced qualitative data that was remarkably positive. The patient reported feeling comfortable doing daily activities like sitting, sitting up both slowly and rapidly, and eating/drinking. There were a few instances that yielded negative results, however. The patient reported irritation and

discomfort during initial insertion of the DHD, as well as a decrease in sound volume when rapidly sitting up and during crunches while eating. Overall, the patient reported normal or improved sound volume, as well as good sound quality, for a majority of the recorded daily activities.

5. Comfortability

Djalilian and Bachman have prototyped a new design for the direct hearing device (DHD) with the intent for commercialization. The design was smaller, facilitates more manufacturing, and has improved fitting. The fitting was due to a removable and replaceable interface tip which was then tested for the frequency response and its overall performance through clinical trials. In order to test the frequency response, a test was set up in which a cup mimicked the tympanic membrane and the actuator made contact with the bottom of the cup. The sound propagated was then projected to the microphone due to the shape of the cup. The mechanical sound waves that the mic receives was electrically sent through a pre amp. This pre amp increased the gain at lower frequencies so that the gain would remain constant throughout a range of frequencies. The sound data was then indexed via a computer sound card. During this test, two cases of mechanical coupling were tested: the two magnets of the set up were in direct contact with the membrane (strong coupling) and a 500 μm gap between one of the magnets and the membrane (weak coupling). The test resulted graphs depicting the strong coupling causes a variable recording of sound over a range of frequencies in contrast to the weak coupling providing a stable dB value overall. After the initial test, another frequency response test was conducted where the length of the stinger was the dependent variable. The frequency response was tested in iterations of 0 μm (the set origin, “original length”), -400 μm , and +400 μm . For this test, the cup was not utilized; instead, a thin membrane was placed between the mic and the actuator. With this setup, the strong coupling arrangement was utilized and the frequency response was tested. When using an iPod as a sound

producer, having the stinger at +400 μm resulted in a similar linear progression to a 0 μm stinger. In contrast, the -400 μm had a stable value approximately -60 dB. To validate the fitting of the actuator's design, a model of the inner ear canal was molded to test it. After the fitting was verified, the new DHD design then proceeded with clinical trial in vitro and in vivo. For this clinical test, a patient was tasked to perform daily tasks such as eating, drinking and walking while equipped with the DHD. The overall feedback from the patient was fairly positive. The patient experienced difficulties during DHD insertion, eating, gulping, and holding in their burp.

CHAPTER 3: Direct Hearing Device Clinical Performance

1. Institutional Review Board – Human Clinical Performance

The role of the researcher precludes any ethical considerations associated with the design of the DHD for commercial manufacture. In the completion of the clinical trial, the researcher assured the participant of confidentiality. The participant was provided with an informed consent form detailing the associated risks and benefits associated with the completion of the trial. In order to reduce the potential risks to the participant, the device insertion and removal was completed within a clinical setting and the settings of the device were assessed prior to the use of the device by the participant to prevent any improper configuration that could otherwise adversely affect the participant. The participant was comfortable with the risks associated with participation and provided their informed consent to participate on the condition of confidentiality. The participant was aware that they could leave the clinical trial at any time, without any penalty to themselves and agreed to the data collection process for the purposes of the study.

2. Clinical Performance Test – Design

The first test utilized an experimental cup test setup utilizing an iPod driver connected to the actuator of the DHD device. A cup with a membrane modeling the tympanic membrane acted as the model for the amplification of the middle ear. A microphone on the other side of the cup was used to collect the frequency responses. A pre-amp and computer sound card were used for gain and to collect the inputs from the microphone. The DHD coil and first magnet had a variance in the distance between magnets on either side of the actuator membrane. The strong coupling had 0 micron distance between the magnets and the weak coupling had a 500 micron distance between the magnets.

The first set of tests conducted were associated with the decibel versus frequency for both the strong coupling and the weak coupling trials. Using the cup test in the manner described in the prior chapter, the researcher explored the different frequency yields based on the different couplings. These results show the average frequency to decibel findings for commercially available devices, presented in green, the results of the weak coupling, and the results for the strong coupling.

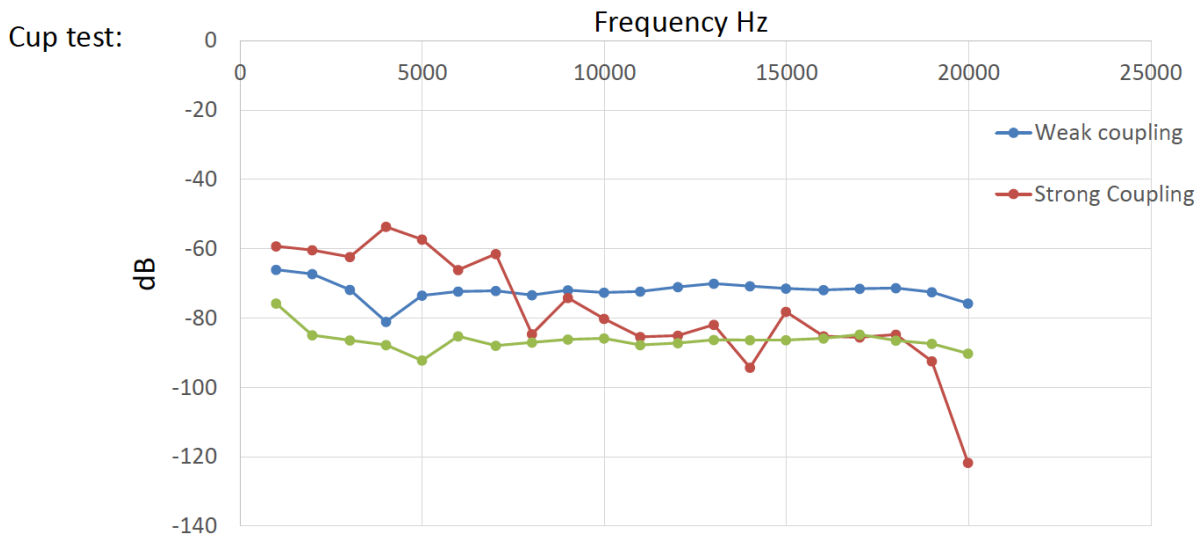

Fig. 60 Cup Test Frequency Results

The frequency responses of the strong coupling are presented in a standalone fashion, allowing for a comparison between the preamp output results and the adjustments for preamp gain. The frequency responses are also presented for the weak coupling, documenting both the preamp output for the cup test of the weak coupling and the adjusted output for preamp gain.

Cup test: Strong coupling

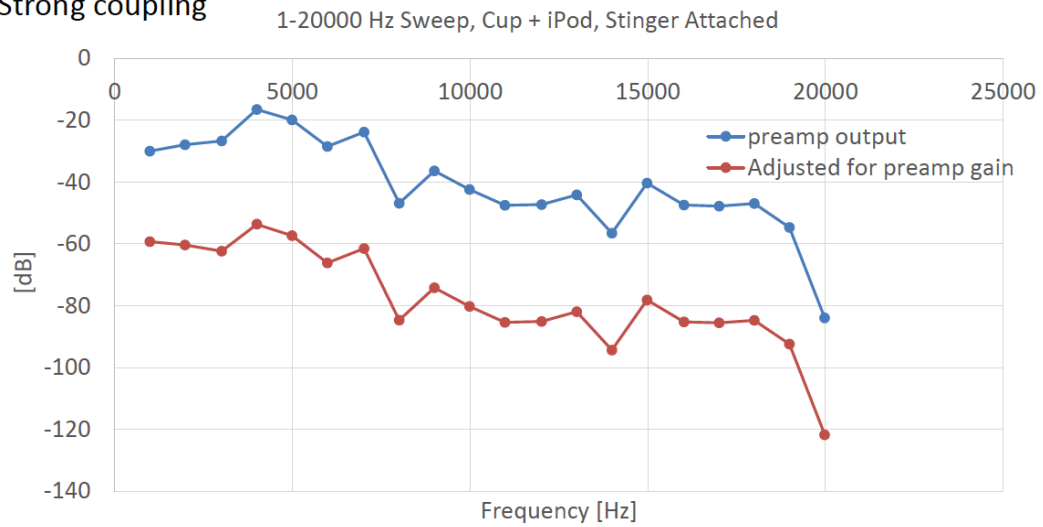

Fig. 61 Cup Test Frequency Responses – Strong Coupling

Cup test: Weak coupling

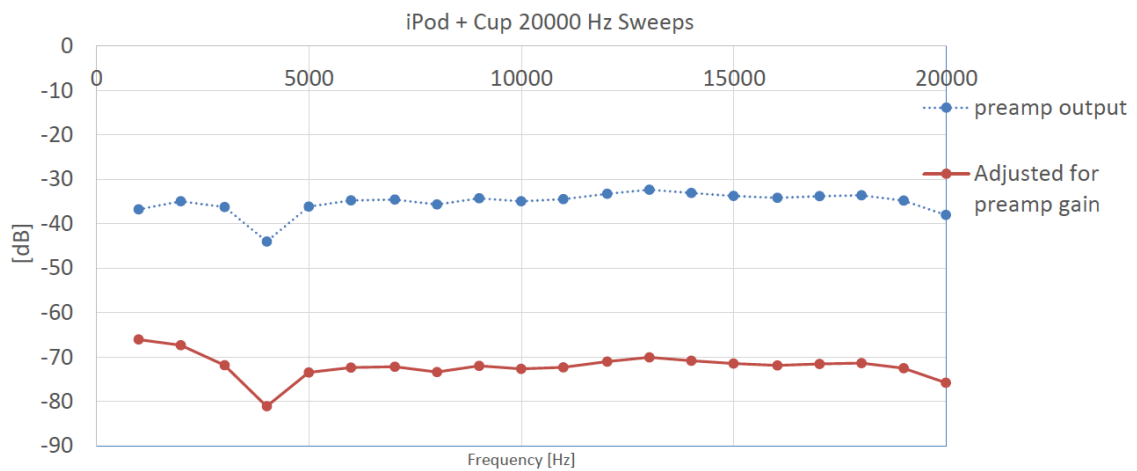

Fig. 62 Cup Test Frequency Responses – Weak Coupling

The paper cup was used to simulate the tympanic membrane in the surface where the actuator made contact. The pulse from the actuator was picked up by the microphone on the inside of the cup to allow the researcher to record the amplitude gain of the device utilizing the pre-amp to convert the weak pulse into an output signal strong enough to limit noise. The main parameter

tested was the coupling (strong/weak) as previously indicated, with the strength indicated by the variation in magnet placement. The frequency response of the high-pass filter preamp was tested with a 9-volt battery. This was used as a baseline for testing the strong/weak coupling. The results seem to show a steady decibel level across the frequency range for the weak coupling, but the strong coupling has a downward slope of decibel gain over increasing frequency.

In terms of the strong coupling, a stochastic response was experienced when the dB decreased with increased frequency. Conversely, the weak coupling led to a relatively consistent frequency response with a slight increase in dB in lower frequencies. This indicates that a weak coupling may be superior to the strong coupling, as this will prevent changes to the perception of sound in a patient when experiencing different pitches, a normal process associated with almost every sound interaction a person has. In addition, the weak coupling is most similar to a natural frequency response.

It was determined that the weak coupling setup yielded more accurate results, as compared to both commercially available devices and as compared to the strong coupling test. The strong coupling picked up more background noise and displayed a greater variability in results and the strong coupling experienced a steep decline in decibels when reaching 19kHz. In comparison, the weak coupling was both more focused and less sensitive to unwanted noise. As a result, these findings show that the weak coupling offered the closest simulation of normal hearing in the most accurate fashion.

These results on their own were not sufficient to make a determination regarding the specific type of coupling to use in the design. Further testing was needed. To test the frequency response of the microphone C, a driver was connected to an actuator-mic C combination, which

was then attached to a pre-amp and computer sound card. The microphone C moved 400 um to the left and right of its original position.

The second test, consisting of multiple trials, allowed the researcher to obtain frequency responses through the completion of the microphone C test. second test resulted in a frequency response graph that allowed the researcher to compare stinger lengths of -400 microns with an iPod driver, -400 microns with a Phonak hearing aid driver, 0 microns with an iPod driver, and +400 microns with an iPod driver.

Microphone C test:

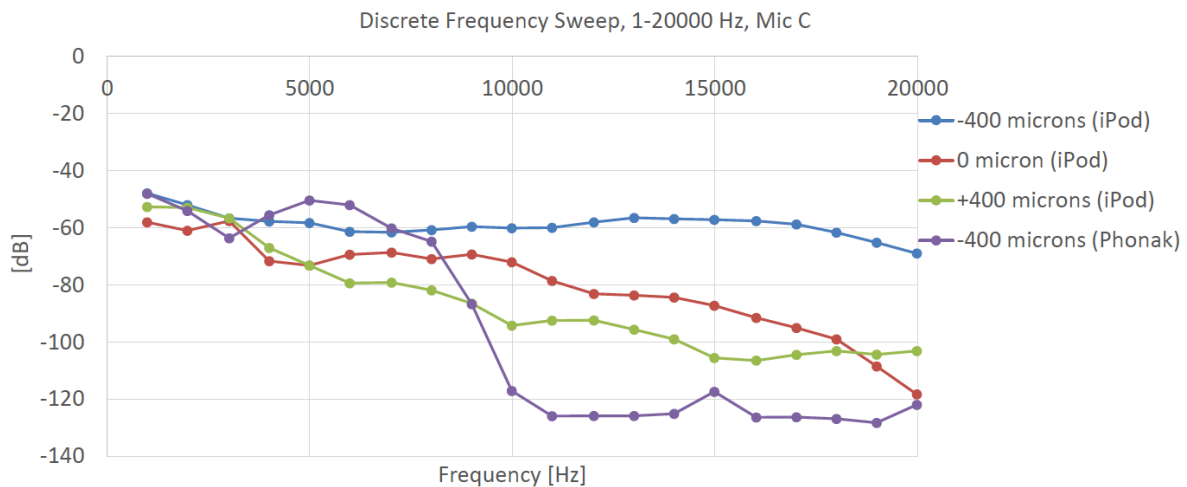

Fig. 63 Microphone C Test Results

The microphone C test moved 400 um to the left and right of its original position. The highest, most stable frequency range was when the microphone C was located 400 um from the left of its original position. The results for the microphone test indicate that changing the length of the stinger drastically changes the frequency response. A noted change is -400 with the iPod driver, which displayed a constant frequency response, as compared to the Phonak’s stochastic frequency response. Based on a graph of the collected data, the results indicate that the -400 microns with the iPod driver yielded the most consistent and accurate results. It is important to note that the Phonak driver resulted in the least accurate results, displaying a large decline in decibels around

8kHz. These findings led the researcher in the identification of the different components that would be present in the creation of the prototype device.

Before the prototype could be created, however, there was a need to design the actuator fittings that would be used in the creation of the prototype. As a result, average ranges were determined for the different components of the ear canal, allowing the researcher to create a design that would maximize fit while still maintaining a certain degree of flexibility. The results associated with these calculations.

Actuator fittings:

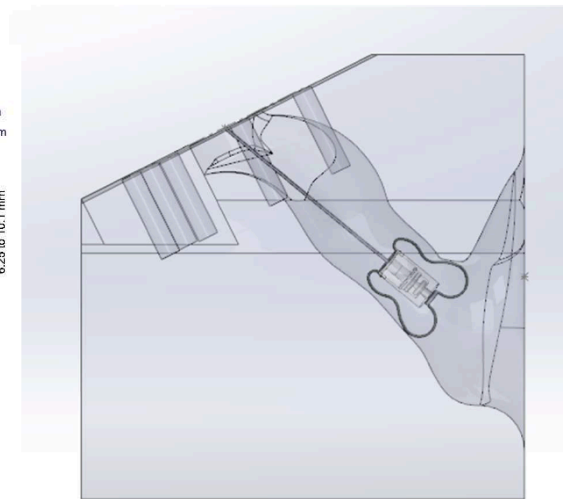
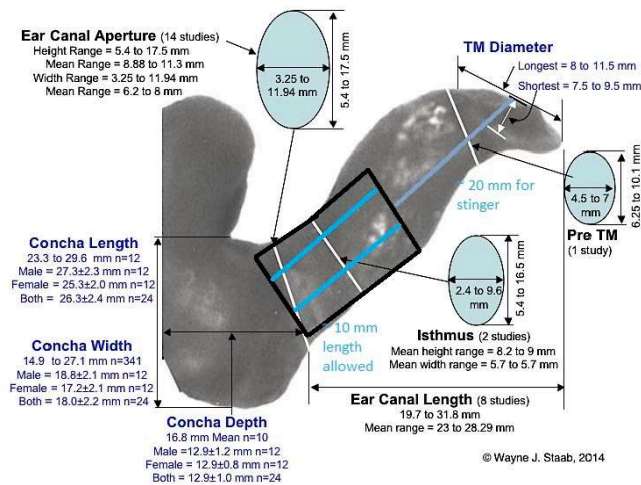

Fig. 64 Actuator Fittings

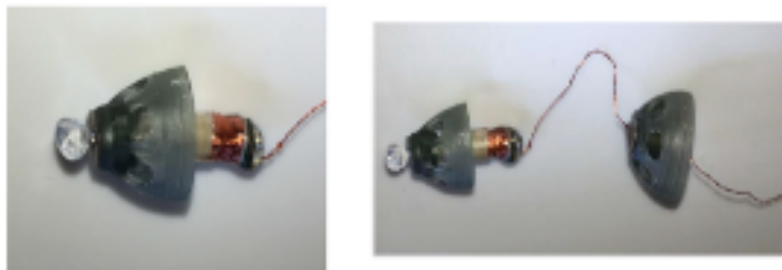

Fig. 65 Fabricated Device

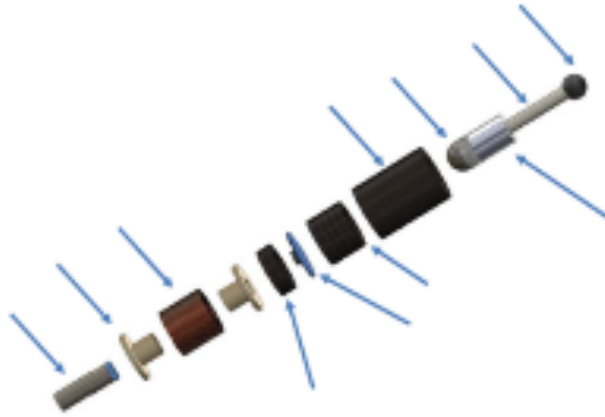

Fig. 66 Fabricated Stinger

Utilizing the information obtained from the design tests, the researcher was able to finalize the design for the prototype and fabricate the device that would be used in the clinical trial testing phase. This was the design that was tested in the model of the inner ear. After the fitting was verified, the new DHD design was ready to proceed with use in the clinical trial.

3. Clinical Performance Test – Frequency

Djalilian et al¹⁹ presented an upgraded version of their prior device with increased manufacturability using standardized parts and a smaller device size. Enhancements to the interface tip and ball bearing led to improvements in mechanical coupling to the tympanic membrane. This presentation ran several studies over its course, including several measurements of frequency responses using varied parameters in coupling distance and distance of the MicC membrane. It was followed by a clinical trial to measure comfortability and perceived loudness.

The first experiment used an experimental cup test setup utilizing an iPod driver connected to the actuator of the DHD device. A cup with a membrane modeling the tympanic membrane acted as a model for the amplification of the middle ear. A microphone on the other side of the cup was used to collect the frequency responses. A pre amp and computer sound card were used for

gain and to collect the input from the microphone. The DHD coil and first magnet remained in a similar setup as prior experiments, however in this experiment they created variance in the distance between magnets on either side of the actuator membrane. The strong coupling and weak coupling had 0 micron and 500 micron distances between the magnets, respectively.

The second experiment utilized a similar setup to the first experiment with an iPod and Phonak to drive the DHD device. This experiment had variance in driver selection between the iPod and Phonak driver as well as differences in the distance between the micC membrane and the stimulator. The tested distances were an iPod setup at 0, +400, and -400 microns, and the Phonak driver at -400 microns. Finally, a clinical experiment was conducted to test comfortability of the device as well as perceived loudness. The clinical experiment looked at comfort upon insertion, sitting, standing up, walking, climbing stairs, eating, drinking, gulping, holding in burping, and removal. It also looked into the sound volume and quality of each event.

In the first experiment, the strong coupling presented stronger frequency responses presented more outliers and inconsistent results in comparison to the weak coupling. The weak coupling had more consistent responses to that of normal hearing. The strong coupling also had a steep drop in decibels around 18 kHz. The second experiment demonstrated the best frequency responses at all ranges with the -400 micron iPod setup. The other iPod experiments had similar results to the first iPod experiment with a more intense drop in frequency response at higher frequencies and an overall smaller frequency response at all frequencies.

The other notable test was the Phonak driver at -400 microns which showed a steep drop and frequency response at around 8 kHz. The clinical experiment showed all of the activities outside of insertion, removal, gulping and holding in a burp were comfortable for all setups. The test showed moderate discomfort upon insertion and a band aid rip effect upon removal. Gulping

and holding in burping were comfortable for the second design, but generated pressure with the first design. Sound volume and sound quality were relatively normal and consistently good, respectively. Perceived loudness of the device was relatively constant at all frequencies with a slight drop as it approached 8 kHz. The driver output was -14 Hz.

4. Clinical Performance Test – Effectiveness

The tasks that the participant undertook during the clinical trial consisted of insertion of the device, sitting while using the device, slowly sitting up while using the device, rapidly sitting up while using the device, walking while using the device, climbing stairs while using the device, eating while using the device, drinking, gulping (using both the first tip designed and the second tip designed), holding in a burp (using both the first tip designed and the second tip designed), and removal of the device. The responses provided by the participant regarding the effectiveness of the device in each of the following areas: comfort, sound volume, and sound quality associated with the device. The results of the clinical trial indicate participant responses in each of these areas regarding the actions.

Clinical trial results: Stability and comfort

| Situation | Comfort in the ear canal and on Tympanic membrane | Sound volume | Sound quality |
|-------------------------------------|---|------------------------------|------------------------------|
| Insertion | Impulses of moderate discomfort/ initial irritation | Varies by quality of contact | Varies by quality of contact |
| Sitting | Comfortable | Normal | Good |
| Slowly sitting up | Comfortable | Normal | Good |
| Rapidly sitting up | Comfortable | Decreased | N/A |
| Walking | Comfortable | Normal | Good |
| Climbing Stairs | Comfortable | Normal | Good |
| Eating | Comfortable | Crunch interferes | N/A |
| Drinking | Comfortable | Normal | Good |
| Gulping (tip designs 1 & 2) | 1- Feeling of pressure 2- comfortable | Increased | Good |
| Holding in Burping (tip design 1&2) | 1- Feeling of pressure 2- comfortable | Increased | Good |
| Removal | Like removing a bandaid | Decreased | Decreased |

Table 1 Clinical Trial Results

The clinical trial produced data that was remarkably positive. The participant reported feeling comfortable doing the activities of daily living explored with the prototype device. There were, however, a few areas in which negative results were reported. The participant reported both irritation and discomfort during initial insertion of the DHD as well as a decrease in sound volume when rapidly sitting up, and a decrease in sound volume when the participant ate something that resulted in crunching. Overall, however, the participant reported normal or improved sound volume in the completion of activities of daily living, in addition to good sound quality, for a majority of the recorded daily activities. Of note, however, is the fact that the variation in volume decreases with rising frequency deviated significantly from the controlled data obtained from the cup test and microphone tests, indicating the variation present between a controlled lab test and the practical use environment of an assistive hearing device.

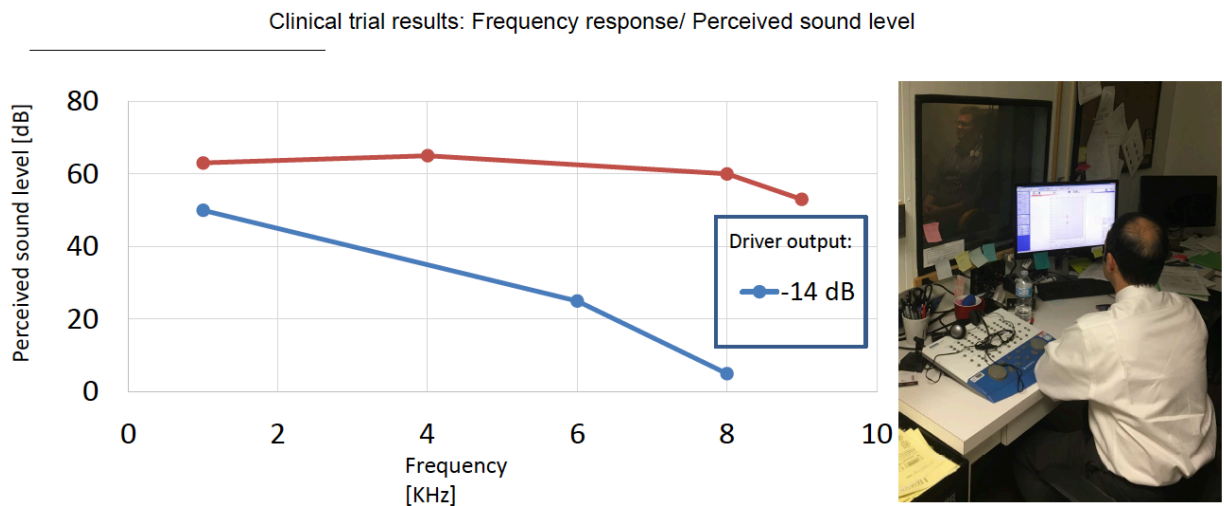

Fig. 67 Clinical Trial Results – Frequency Response vs. Perceived Sound Level

5. Discussion

The direct hearing device (DHD) is a neoteric hearing prosthesis designed to combine the advantages of both conventional commercially available hearing aids and middle ear implants in a single device that both addresses the issues associated with current hearing aid technology while

removing the detriments associated with implants, namely the need for invasive and costly surgery. The DHD is intended to fall in a middle ground between the two, with the best of both types of devices present and none of the downsides associated with their respective use. The DHD designed in the completion of the current study is a complete inside the ear canal device that cannot be seen while inserted, thus addressing cosmetic concerns that the patients in need of hearing assistive devices may have regarding their appearance.

Temporal testing of the prototype of the DHD designed in the completion of the current study showed that the device can drive the ossicular chain at similar displacements to those found with acoustic stimulation given the effectiveness of the coupling with the tympanic membrane. The frequency response of the device was evaluated using a laser Doppler vibrometer with varying stepped sine waves from 0.3-12 kHz at varying voltages. The first set of results described indicate that the device did not produce a noise that was greater than the average background noise present in a quiet listening environment. Still further, the DHD created in the completion of the current study linearly reacted to the increase in mV, where a higher voltage simulates a louder sound.

The bench testing of the DHD showed that low distortion movements produced by the DHD were similar to the displacements and frequencies found in normal, non-assisted hearing in individuals who were not previously diagnosed with any form of hearing loss. This suggests that the DHD prototype created in the completion of the current study offers hearing capabilities that are comparable to those of a person who does not experience hearing loss in any form. To be able to mimic non-assisted hearing of an individual without hearing loss in a person with moderate to severe hearing loss utilizing a hearing assistive technology is the ultimate goal of hearing assistive technologies. The collected results associated with the prototype suggest that these hearing capabilities are possible based on the results obtained through the non-human tests; however, the

clinical trial results show that this level of hearing was not possible with the device in certain areas, suggesting the need for further testing within a larger sample pool.

The transmission of sound information by the DHD prototype occurs through the mechanical moving of the tympanic membrane. This process was proven through the completion of the short term single subject clinical trial. Prior to the clinical trial, it was predicted that the DHD would be coupled on the umbo of the tympanic membrane. Through the completion of the trial, useful information was obtained regarding the importance of the coupling location. During the completion of the clinical trial, the 46-year-old male had the device placed in his right ear against the tympanic membrane using alligator forceps with the external sounds directed inside his left ear using headphones. Pure-tone sounds of various frequencies were played through the DHD in the right ear and in the headphone in the left ear, with the loudness increased incrementally. The subject was asked to indicate when both sounds were perceived as equal. Again, during the clinical trial, several changes were made including a smaller device diameter, the use of the two different tips, and the use of a softer plastic in the creation of the device. The same participant utilized the changed device on a different day, completing the same actions as were required in the completion of the first day's trials. This trial differed in that the sounds played contained four lists of 50 consonant nucleus consonant monosyllabic words. The first two tests yielded beneficial quantifiable results, in addition to the generation of other finds that were not sought after or anticipated. Namely, that the acoustic noise generation was not detectable in a quiet listening environment and that the force that was generated by the actuator used in the creation of the prototype was both controlled and reproducible. The completion of the clinical trial led to the conclusion that the placement of the DHD against the lateral process of the malleus yielded the best results in terms of clarity of hearing. This finding was in alignment with the findings of Paulick

et al¹⁸ who likewise indicated that placement of hearing assistive devices against the lateral process of the malleus offered the best results in terms of hearing clarity.

Looking back to the first test, the results indicated that the strong coupling presented with stronger frequency responses, but more varied frequency responses, decreasing the overall effectiveness of the use of a strong coupling in the creation of the DHD. The decreased effectiveness was due largely to the greater number of outliers and the high level of inconsistencies in the recorded results in comparison to the results obtained from the weak coupling. The weak coupling offered the most consistent responses and the most similar results to those of normal hearing, defined as hearing without hearing loss in the average adult. The second experiment demonstrated that the best frequency responses at all ranges were found with the -400 micron iPod setup. The other iPod alternatives had similar results to the first iPod setup with a more intense drop in frequency responses at higher frequencies and an overall smaller frequency response across all frequencies. The Phonak driver test conducted at -400 microns showed a steep drop and frequency response at around 8 kHz, indicating that the iPod driver should be utilized based on the poor frequency response of the Phonak driver.

Finally, the clinical test of the DHD design showed that all of the activities tested outside of insertion, removal, gulping, and holding in a burp were comfortable across both tests. The clinical trial showed that moderate levels of discomfort were present upon insertion and that the participant indicated that there was the sensation of removing a band aid upon removal of the device. Gulping and holding in a burp were comfortable with the second design in which the softer plastic was utilized in the prototype but were reported to have uncomfortable pressure associated with the acts when using the first prototype. Sound quality and sound volume were reported to be relatively normal and consistently good. The perceived loudness of the device was relatively

constant at all frequencies, with a slight drop as it approached 8 kHz. The driver output for the device was recorded at -14 Hz.

As the test results indicate, the new design evidenced in the DHD prototype is smaller than current commercially available hearing assistive devices. The DHD prototype also has a higher level of manufacturability than the previous design given the use of standard materials and processes in its creation. The tip and the actuator were developed separately. As a result, the interface tip is removable and replaceable, allowing for both more mounting options on the part of the physician and increasing the ease of maintenance and repair for the device, aspects of consideration recommended for inclusion by the WHO⁸⁸. The use of a ball bearing in the design will allow for the angular movement of the arm of the device for better mechanical coupling with the tympanic membrane, suggesting a potential area for improvement within the device itself. Even if this change is made, the DHD will still cost less than the current commercially available hearing assistive devices on the market, and the simplicity of the design works to ensure that the device is ready for commercialization.

When comparing the design of the DHD prototype to the WHO requirements set for hearing aid technology, each of the criteria considered essential and many of the qualities that were identified as desirable are found within the created design⁸⁸. The device is both comfortable and easy to wear⁸⁸. The two areas of discomfort experienced by the single participant in the clinical trial will need to be explored in greater detail through the completion of a larger clinical trial with multiple participants in order to determine whether this was a discomfort issue experienced by a single individual or whether this is a recurring discomfort issue that will need to be addressed. The DHD prototype does use digital technologies as is required by the WHO as an essential component⁸⁸ through the use of the iPod driver. The hearing aid format is not a behind the ear aid,

as is preferred by WHO due to the greater ease of fit, however, the flexibility of the soft plastic and the separate tips works to ensure that the concerns associated with growth with age are addressed through the DHD prototype⁸⁸. The performance requirements specified by the WHO are met through the use of real ear measurements as explored through the clinical trial and the associated fit and placement process⁸⁸. The design is robust and the nature of the device means that it can be tailored to the prescription specifications of the individual, both of which are requisites laid out by the WHO⁸⁸. The WHO also indicates that compression systems, feedback management, and volume control are essential, all components that are present within the device⁸⁸. The device also does have a way to power down as is required, and the device includes adaptive noise reduction systems to address background noise concerns, as was evidenced within the trial results associated with the design process⁸⁸. Direct audio input is present in the DHD prototype, another quality identified as desirable by the WHO and the design was made with affordability in mind, ensuring that the devices could be made at low cost⁸⁸. As the device is still in the prototype phase, the model information and packaging considerations are not yet a concern; however, the repair and post fitting services are present, ensuring the potential for endorsement in the device's use⁸⁸. The fact that the device was indicated, during the limited clinical trial to be comfortable for use while meeting a high level of the requirements outlined by the WHO while still meeting many of the desired features beyond the minimum suggests that the design of the prototype 2 DHD is on the right track for success. As a result of these findings, the prototype is tentatively a strong tool for treating hearing loss, as well as potentially contributing to a higher quality of life by users. It is expected that, as a result of the affordability, it will be possible for more people to take advantage of the DHD prototype for improved hearing.

CHAPTER 4: Summary and Conclusions

This study serves as documentation for the design and creation of a direct-drive hearing aid device intended to sit in the inner ear canal of the individual with a diagnosis of moderate to severe hearing loss. The study was divided into two distinct parts. The first part of the study was focused on the design of the direct hearing device (DHD) and the creation of the prototypes for that device. The second part of the study consisted of a limited clinical trial intended to determine the effectiveness of the device. The results of the study indicate that the new design is feasible for production, it does amplify sound more effectively in comparison to currently available devices on the market, and preliminary findings indicate that the device is comfortable in the completion of common activities associated with use. As a result of this study, there are increased opportunities for further advancement of the DHD, which will be beneficial in the context of growth in treating hearing loss through multiple elements. The methodologies and tests conducted in the present study are important because they show the feasibility of the prototype based on different elements, including patient comfort. This will potentially lead to an effective treatment in the long-term, which will help in advancing hearing loss treatment options for patients with different levels and types of hearing loss. The study is important in the short- and long-term for the alleviation of hearing loss difficulties. However, it is acknowledged that the prototype will not act as a cure but can be used to supplement the life of the wearer, leading to improved outcomes and the provision of new opportunities for hearing.

The problem this study sought to explore was the design and creation of a new hearing aid device that still had all of the benefits of current hearing aid technologies while simultaneously working to reduce the associated detriments with preexisting hearing aid technology. This goal was to assist in providing a hearing aid that would assist more people with different needs. This

meant that the improved DHD could be more effective than current options. As such, it is important to realize that the current study is a limited cohort yet is promising for future outcomes. The purpose of the current study was to design a new hearing aid prosthesis that would address the previously identified problems with both current hearing aid technologies and implantable device technologies while simultaneously maintaining the advantages present with current common use hearing aid and implantable device technologies. In order to accomplish this task, the researcher worked to design a DHD that would fulfill the stated requirements of the study. Through the completion of this experimental study, a DHD was designed and several prototypes were created; these prototypes were then tested in a clinical trial consisting of a single participant.

The results from this limited clinical trial led the researcher to the conclusion that the device could be stated to maintain the advantages present to using current common use hearing aid technologies and current implantable device technologies without the associated detriments indicated regarding their use. Within this final chapter of the research study, a summary of the study findings is provided along with the documentation of the conclusions made as a result of the completion of the study. In addition, the limitations identified throughout the course of the current study are discussed and recommendations are made for both potential areas of future study and recommendations for implementation. The chapter concludes with a discussion of the researcher's thoughts regarding study completion. In some instances, the completion of a study serves as the conclusion of the researcher's involvement in the process, however, when a study works to detail the design of a newly created device and the subsequent initial testing of the designed device, oftentimes the researcher's work is only in the beginning stages. Although this chapter serves as the final documentation for the completion of the current study, much work still remains before the device described herein will be ready for marketing and mass production.

1. Summary of Findings

The current study was divided into two sections, representing both the design process through the creation of the prototypes that would be utilized during the clinical trial and the limited clinical trial itself. The design process started with a review of currently available devices found in the hearing assistive device market. This review allowed the researcher to identify both the most frequently employed designs and identify the common problems associated with each. Utilizing this information, the researcher worked to design a new direct hearing device (DHD) that would maintain all of the positives associated with current hearing assistive technologies while negating or modifying design aspects associated with these devices that incorporated elements that those who require the use of hearing assistive devices had indicated that they found to be frustrating, annoying, uncomfortable, or otherwise undesirable.

After the creation of the DHD design, and the subsequent testing of individual components associated with the design to ensure that the performance of those components was in alignment with the projected performance associated with the design itself, the next step was to create a prototype of the DHD. The first prototype was created and prepared for testing in the clinical trial. A second prototype with slightly softer plastic was also created in order to provide a comparison regarding design effectiveness. The only difference between the two prototypes was the tip placed on the end of each; more specifically, the only difference was the type of material used in the creation of the two tips. The prototypes were then employed in the completion of the limited clinical trial.

Due to COVID-19 concerns, a limited clinical trial was conducted. The participant for the limited clinical trial was an adult middle-aged male with moderate hearing difficulty. The device was designed for use by those with moderate to severe hearing difficulty, making this participant

an ideal candidate for conducting preliminary trials using the prototypes. While the use of a single participant in the clinical trial worked to limit the overall generalizability of the study findings, careful consideration led to the justification for this decision. First, as a result of the COVID-19 pandemic, new ethical considerations are coming to light within the research community that suggest that the request for a multi-participant in-person study may be an ethical concern in the completion of active human participant based research studies at this time due to the potential for the virus to spread in an airborne fashion, creating health hazards for both the researcher and any potential participants in the study^{90,91}. Second, due to the ethical considerations associated with the use of human participants and the need to prevent potential harm from coming to those participants in the completion of a research study, there is not sufficient justification for a multi-participant study in the completion of the current study at this time^{90,91}.

The use of a single participant in the collection of data during the limited clinical trial worked to reduce the potential for harm to both the researcher and the participant while still providing sufficient data regarding the effectiveness of the prototypes. As the purpose of this study was to design and confirm the effectiveness of the DHD design, in light of these health-based considerations, justification was not present for the inclusion of multiple participants. Yet, a single participant would be able to, and was able to, provide the data necessary to confirm the effectiveness of the prototype. With this study delimitation in mind, the clinical trial was setup and completed, with the researcher collecting data as the participant completed different types of activities. The results associated with the initial harder plastic prototype and the softer plastic prototype were compared and the prototype created with the softer plastic was more comfortable for use. The data collected during the completion of the clinical trial indicated that the design

created by the researcher did what it was intended to accomplish, leading to the conclusion of the study.

2. Purpose Resolution based on Findings

Three research goals were identified for resolution during the completion of the current study. With sufficient data collected to allow for the resolution of these research goals, it is necessary to go back and resolve the identified research goals.

The first research goal was based on the determination of the feasibility of the new design for potential production opportunities. The prototype was created with low-cost components and was made easily within a non-production environment. The combination of these factors means that the design is feasible for production. The low cost of components necessary to create the DHD, a cost that would decrease with the purchase of those components in bulk, lends credence to the feasibility of the design for production. Still further, the researcher's ability to create two prototypes in a non-production environment likewise suggests the ease of DHD creation within a production environment. Based on this information, it can be argued that the device is feasible for production and can lead to increased production as it becomes more popular within the mainstream population.

The second research goal was based on the determination of effectiveness in sound amplification by the new device, as compared to current hearing aid technology options that could be utilized. This includes all types of current options that can be found on the market and at different prices. In order to explore the information needed to resolve this research goal, two different approaches were used in the completion of the current study. First, during the design process, the researcher compared the effectiveness of amplification using the cup test to compare the different design components against current market offerings. The results of these tests, which

are displayed within the preceding chapter, all serve to indicate that the DHD design created for the purposes of this study provided a higher level of amplification as compared to devices currently available on the market. With this information in mind, the researcher moved on to the completion of the clinical trial. The results of the clinical trial indicated that the prototype device was better at amplification than currently available devices, however, the amplification when the device was used in ear was less strong, as compared to the results prior to insertion. These findings may be user specific, meaning that these variations may not be present in all users of the DHD design, however, in order to determine whether these findings are a deviation between design and insertion, potentially resulting in the need for additional changes, or whether they are specific to the user in the limited clinical trial would require additional testing. In spite of this variation, it can be concluded that the new device does, in fact, amplify sound more effectively than the devices currently available on the market. The increased efficiency will be a strong point for encouraging participation, especially if it meets the other needs, such as price, comfort, and visibility.

The third, and final, research goal was in relation to the device sitting comfortably in the ear of an adult human during activities of daily living including sitting, walking sitting up, climbing stairs, consuming food, and so forth. Table 1, located in Chapter 4, provided the results associated with the completion of different activities during the limited clinical trial. The results from the limited clinical trial show that the device did sit comfortably in the ear during sitting, slowly sitting up, rapidly sitting up walking, climbing stairs, eating, and drinking for both the hard plastic and the softer plastic prototypes. In the instances of gulping and holding in burping, the harder plastic prototype (prototype 1) produced feelings of pressure, but these feelings of pressure were not present, and the device sat comfortably in the instance of the softer plastic prototype (prototype 2). In the instances of prototype 1 and prototype 2, both had moderate discomfort and initial irritation,

respectively, upon insertion and both felt like they were removing a band aid when the prototypes were removed. There was no clear indication as to whether the insertion and removal discomfort were user specific or whether these periods of discomfort were specific to the devices themselves. In responding to the final research goal, it can be confirmed that the new device, more specifically, prototype 2, does sit comfortably in the ear of an adult human during activities of daily living including sitting, walking, sitting up, climbing stairs, consuming food, and so forth. It is noted that the differences in the prototypes led to differences in comfort by users. As a result, it could be that two prototypes can be more beneficial for effective production. This may lead to increased options for consumers, as well as meet increasing varieties of needs based on individual circumstances.

3. Conclusions

In conclusion, it can be stated that while both prototype 1 and prototype 2 meet the specifications detailed prior to starting this study, any advance movement with this DHD should be confined to the use of prototype 2 or should involve modifications to prototype 2 in order to continue to work toward additional improvements. Although prototype 1, with the harder plastic, does meet the base minimum requirements set forth to be achieved in the completion of this study, the fact that there was discomfort in two of the common activities tested in the clinical trial that an average person is likely to engage in while using the DHD, this means that prototype 1 does not address all of the desires of the researcher in the creation of the design, nor does it mean that it is likely that a person would select the prototype 1 DHD when given the option to choose between the two.

In the completion of the design process, prototype 2 performed better than prototype 1. During the course of design and prototype creation, particularly in instances in which the prototypes created have only slight variations from one to the next, it is typical that one prototype

will perform better than the others. In instances in which the prototypes are similar and have similar results, the prototype that should be used moving forward is the one in which better results are obtained regarding use. This means that the second prototype, with the softer plastic used in tip creation, should be the design employed moving forward. Justification for the use of the second prototype going forward can be found in similar products placed in the ear of the individual; it is for this reason that many headphone manufacturers have switched to the use of softer plastics in earbud creation; not only are they considered more comfortable by a larger group of people, but they also conform, as a result of the use of softer plastics, to the shape of the ear of the individual better than the harder, less forgiving plastics. The same holds true in the completion of this limited clinical trial; the softer plastic tip present in prototype 2 was found to be more comfortable, and while the generalizability of this information is limited, given that these findings are in alignment with previous commercial application explorations with goods that are placed within the ear itself, it is reasonable to state that this is the design that should be used moving forward. This also means that considerations will need to be made for differences in sizing for different individuals based on need.

4. Limitations

Several limitations were identified prior to starting this study and can be found in other areas of the study. The first identified limitation was present in the fact that the prototype design comfort level was only measured in the short term, during the collection of data in the limited clinical trial and would not provide information on the level of comfort associated with device usage over time. The two prototype devices were tested for comfort only for the amount of time necessary to collect data for the purposes of resolving the identified research questions. Further testing would be needed regarding the comfort associated with use over different durations. A

second limitation identified was that the findings regarding comfort were limited to a single geographic area, which means that no data was collected as to how changes in altitude, climate, air pressure, barometric pressure, or other weather conditions would influence comfortability of the device or device effectiveness.

During the design of a research study, however, it is not possible to identify all of the potential limitations that may arise in the completion of a study. Still further, while some limitations identified prior to the start of the study can be mitigated, others cannot; what's more is that even if a researcher does attempt to mitigate identified limitations during the context of a single study, this is no guarantee that those attempts will work to lessen or mitigate the identified limitations. To this end, there is a need at the completion of a study to identify all other limitations that arose during the completion of that study. In this way, not only is the researcher working to ensure transparency in the findings, but the researcher is also laying out these limitations for the next researcher to address, should test-retest reliability be applied to the findings of the current study.

With these factors of consideration in mind, this section works to detail the additional limitations that arose during study completion. The first limitation that warrants attention is the limitation associated with the completion of a limited clinical study. While the use of a limited clinical study was justified in light of the current global pandemic^{90,91} this does not mean that it is not without its own limitations. The use of a single participant in the completion of the clinical trial prevented the findings from being generalizable to other contexts. The use of a single participant also did not provide sufficient data to ensure that the findings were applicable across multiple individuals. Variations in physiology from individual-to-individual mean that these findings may not apply to a person with a notably different physique or notably different variations

in ear canal size. Of further consideration is that the gait of different persons presents differently, which can cause changes in how the DHD may sit within the ear canal of different individuals. In light of these limitations, there is a need for further testing to determine whether the comfort levels reported by the participant in the limited clinical trial are accurate across participants with varying characteristics.

An additional limitation associated with the completion of the study is the fact that the effectiveness of the DHD in the ability to maintain sound quality was collected in a sanitized environment, meaning that there was no additional background noise present beyond that what was present in the room. In order to determine whether these findings carry over to the real-world environment in which the device would be utilized, there would be a need to test the device's effectiveness in other circumstances. For example, is the sound quality still effective when two adults are attempting to talk to one another and children are present in the background, yelling, screaming, playing, and generally carrying on? Is the sound quality still effective when people are in a vehicle and road noise, radio noise, and conversation is present? Is the device still effective in terms of sound quality when the person wearing the device is attempting to have a conversation in an office building where there are other electronic noises and other conversations present? Is the device effective in terms of its sound quality when worn to a club, to a restaurant, to a movie theater, to an arcade, etc.? It is one thing to indicate that the sound quality of a device in a clinical environment is better than the average device on the market, however, if that device does not perform at comparable levels in instances in which the individual is completing the day-to-day tasks associated with their responsibilities, with their job duties, or with their entertainment activities, then it cannot be stated that the DHD is better. As a result, it can only be stated that the DHD performed better in clinical testing as compared to the other devices currently available on

the market, which does prove to be a limitation associated with the applicability of the study results.

It is important to note that while it may initially appear that the number of limitations associated with the completion of the current study has increased dramatically, this list is ultimately quite small when taking in the scope of what has been accomplished in the completion of this study. Prior to the start of the current study, the researcher only had a rough idea in mind as to what would be accomplished through the completion of the study. There was not even a basic sketch of the DHD that would be created through the completion of the study. Yet, when starting from nothing more than an idea, this research study moved through the research phase to the design phase, allowing the researcher to sketch out the different design elements associated with the device creation. Once the basic design was fleshed out, the researcher was responsible for identifying the exact specifications for that device, along with identifying the best materials to use in the creation of the prototype. Following the completion of these tasks, the researcher then had to obtain the materials and determine the best way to create the prototypes based on potential variations in design, as indicated through the cup test. After all of these activities were complete, the researcher was then required to create the prototypes, determining whether the design, as it was generated, was possible to turn into a physical conceptual device. After the conceptual device was created, the researcher was then tasked with the creation of the two prototypes, including the variations in ear tips. This included the acquisition of all materials necessary to create the devices in addition to the process of manufacturing the prototypes themselves.

Once the prototypes were created, the researcher still was not complete with the study; the next step was to conduct the limited clinical trial and obtain the data from the participant regarding the prototype effectiveness. These findings were then recorded and the study write up was

presented, along with the resolution to all of the research questions. Ultimately, the completion of this study was no small feat. Each of these activities could have been conducted in a separate study all their own, making the current study an extensive undertaking. These limitations were not limitations that could have been mitigated or negated, given the infancy at which this study commenced. It is the acknowledgement of these limitations that serves to strengthen the current study, and it is these limitations that lend insight into the next steps that will need to be taken before the prototype 2 DHD device is ready for manufacturing.

5. Recommendations for Implementation

The recommendations for implementation refer to the actions that can be taken using the data as presented from the study findings. As the current study was associated with the creation of a DHD prototype and preliminary testing of that prototype, the recommendations for implementation are focused on the next steps following the prototype's creation. Based on the results associated with the testing of the prototype, as presented in prior chapters, the next steps for implementation are to file a patent for the DHD, ensuring that the information documenting the device creation is proprietary to the researcher. The attainment of a patent for this device does not mean, however, that the researcher should cease exploring the prototype DHD nor does it mean that the researcher should not continue to make refinements to the device, rather, this step in the process works to ensure that the researcher will be able to maintain control of their intellectual property.

As the researcher does not have manufacturing capabilities and as there are still additional questions that must be resolved before the device can be manufactured, the next step in the implementation of these findings is to start to conduct the additional tests necessary to confirm the effectiveness of this design. This means the creation of additional prototypes to ensure that a

sufficient number of devices are held within the researcher's possession to be able to obtain statistically significant results. The detailed explanation of the different tests that must be conducted following the creation of additional prototype 2 DHD are discussed in the following section, under recommendations for areas of future study. The data obtained from the completion of these recommended areas of study will provide the researcher with the information to know whether additional modifications are necessary to the prototype 2 DHD or whether the prototype 2 DHD can start to be manufactured for use within the hearing-impaired population.

In addition to the recommendations for implementation concerning the filing of the patent for the prototype 2 DHD and the creation of additional prototypes that can be used in the completion of future studies, the results of the current study can be utilized as a means of justification for the acquisition of additional funding to complete the studies that are still necessary before the prototype is ready to be marketed, as described in the subsequent section. This may include applying for grants or working to find a place in a corporate research and development team as a means of gaining additional funding that can be used to further develop the prototype. Due to the complexity associated with the further testing that will be necessary before the device is ready for market, and the amount of time that this testing will take, there is a need to ensure that appropriate funding is in place before proceeding.

6. Recommendations for Areas of Future Study

Across all chapters found within the current study, several different areas of additional study necessary before the DHD designed in the completion of this study have been mentioned. Once these additional areas of study have been explored, the researcher can make a determination as to whether additional changes to the device design are necessary or whether the device design can be manufactured for commercial use. Within this section, each of these recommended areas

for future study is described, allowing the reader to understand the next steps in the process associated with taking a concept through the design stage, prototype creation stage, and testing stages prior to manufacturing.

The first recommended area for future study is to conduct a second clinical trial with longer durations of use. Even with the softer plastic tip design present in prototype 2, short term use of a DHD does not necessarily mean that the comfort level associated with the use of that device will be the same in the mid-term or in the long term. The clinical trial conducted in the completion of the current study was limited in nature, meaning that the results obtained required the participant to engage in the actions stated in Table 1 only using both prototype 1 and prototype 2. This means that the comfort level recorded was only associated with the single completion of each of the listed tasks. Any device worn by a person will have a different comfort level over time. It is for this reason that shoes can seem comfortable when they are tried on, but when they are worn all day that comfort level can vary widely. The same holds true for clothing worn, undergarments worn, jewelry worn, hair accessories worn, and even inner ear devices; a pair of ear buds, a headset, or headphones may be comfortable to wear over the course of a single song or a single conversation but will feel very different if they are worn consistently for an eight-hour period of time. As a result, there is a need to conduct additional tests with the prototype 2 DHD with longer durations. It is recommended that a 2-hour duration test, a 4-hour duration test, a 6-hour duration test, an 8 hour duration test, and a 10 hour duration test are conducted to ensure that the comfort level remains consistent with use over time. While certain limitations will be present, particularly if such testing is completed during the pandemic, the collection of data regarding comfort over time is essential to understanding the potential effectiveness and desirability of the device on the market.

The second recommendation for an area of future study comes from the second limitation. Data was collected during the completion of the study from a single geographic area, which means that the findings regarding the effectiveness of the DHD in the inner ear canal are limited to areas with similar geographic features. Different geographic areas have different altitudes, climates, level of air pressure, barometric pressures, and different weather conditions. Different geographic areas and their associated conditions, have different effects on human hearing. A person in an airplane must pop their ears in order to acclimate to pressure changes in order to hear effectively. A person traveling from one part of a state to another will have to make adjustments to any devices used to hear depending on the conditions in that area. For example, a person located in Houston, Texas may be able to comfortably hear with a listening device set at a particular volume but will have to make adjustments to that device in order to maintain the same level of hearing when visiting the panhandle due to changes in pressure and weather conditions (constant winds). To this end, there is a need to determine whether the device maintains the same levels of sound quality and volume quality in different geographic locations, with minimal modifications. If the device is unable to maintain performance no matter the location of the individual, the effectiveness of the device will be limited. As the device is an inner ear canal device, there is a need to ensure that the user of the device does not have to make constant modifications, as this detracts from the overall benefits associated with the DHD. Pressure changes from coastal areas to mountainous regions likewise result in hearing variations due to the aforementioned geographic changes, which may lead to changes associated with the comfort level of the device. To this end, additional testing is needed to determine effectiveness, ideally with the same individual testing the DHD from region to region or simulated region to simulated region in order to determine effectiveness. In addition to these considerations, high dust areas, high salt areas (coastal areas), and other similar

environment related variations must be explored to determine the impact of these environmental changes on the device itself. If exposure to a particular environmental element decreases the effectiveness of the device or causes damage to the device, this information must be known and addressed before the prototype goes into production.

After the aforementioned recommended studies are completed and any changes made to the DHD as necessary based on the findings of those aforementioned studies, the next recommended study for completion is a larger scale clinical trial. There is a need to understand whether the comfort and device effectiveness levels identified by the single participant in the limited clinical trial conducted in the current study are uniform or whether there are variations associated with other individuals. Variations in physiology are common from person to person and as a result, there is a need to collect data regarding the comfort and effectiveness of the device in people of all genders and in people of all ages in order to determine what changes, if any, should be made to increase the overall effectiveness and comfort of the device. In order to collect this data, a qualitative study should be conducted, allowing participants to both rate the features of the device on Likert-style scales as well as providing their thoughts and perspectives regarding the device including what they like and what they do not like about the device as compared to their current hearing assistive device. In addition to obtaining information from people of different genders and ages, the participant pool should include a variety of participants who utilize different brands and styles of current commercially available hearing assistive devices, allowing for the greatest degree of comparison regarding the product's effectiveness and comfort in comparison to current commercially available devices.

The final limitation discussed earlier in the present chapter had to do with the effectiveness of the DHD in the maintenance of sound quality. The current study collected data regarding the

sound quality and effectiveness of the prototype 2 DHD within a sanitized environment, meaning that there was no additional background noise present beyond the noises made by the researcher, the participant, and the completion of the actions asked of the participant for testing purposes in the limited clinical trial. The real world is far noisier than a research environment, however, and it is for that reason that there is a need to conduct an additional clinical trial in noisier environments. This means collecting data in different physical environments, such as entertainment venues, different home environments in which multiple people in multiple roles are present, and different working environments. The effectiveness of the device in an office environment may be different from the effectiveness of the device in a construction environment, for example. The goal in creating this device was to ensure that it maintained the same quality as devices currently available on the market while addressing the detriments present in those devices. However, until the prototype 2 DHD is tested within a variety of different environments, it is not wholly possible to state that the prototype 2 DHD is more or less effective than current commercially available hearing assistive devices. The goal of this device is to create a lower cost more effective device; however, such a claim cannot be made unless the device is more effective in all possible environments. To this end, a great deal of further testing is necessary in order to ensure that the device operates better than current devices in the completion of the day-to-day tasks associated with their responsibilities, their job duties, and their entertainment preferences.

It is important to note, however, that once each of these different testing phases are completed, the information attained as a result of the completion of these subsequent studies will need to be analyzed and incorporated into the current design for prototype 2 DHD, with potential additional modifications made to the device depending on the results of each of these studies. The completion of these recommended future studies should be used to inform the changes that will be

made to the device, which may, in turn contribute to the need for additional studies as more limitations are identified and as additional needs, wants, or desires are taken into consideration. When working to design a product that will be used to fulfill a human need, the device must work to fulfill as many needs as possible, particularly when the device being created is intended as an assistive device. Future studies with participants of multiple ages and multiple genders may lead to the identification of other aspects that have not yet been taken into consideration.

7. Thoughts on Study Completion

Following the completion of a study, it is common for the researcher to reflect on the study experience, the triumphs, and the challenges faced during the completion of the study. In the completion of the current study, the identified limitations present within the study were largely present as a result of the current global pandemic. While it is easy to acknowledge that a great deal more research is necessary before the prototype 2 DHD is ready to transition to a marketable device, the results of the current study, both during the design phase of the study and during the limited clinical trial were encouraging.

The prototype 2 DHD performed better than expected, and the decision to modify the prototype to create two prototypes to explore the variations in comfort associated with the different tips proved to be a critical design boost that allowed the researcher to highlight the need for inner ear comfort with the use of the softer plastic tip. This particular decision ultimately proved to be a boon because it means that with the next round of testing associated with this device, the decision to move forward with the softer tip means that there is already a greater chance for increased comfort, as compared to the initial prototype. Each design change works to advance the creation of this device, and the immediacy of results improvement from one prototype to the next provided a greater incentive to continue.

While the device has a long way to go before it is ready to be marketed, many of the larger challenges associated with the initial design process have already been addressed, making this researcher confident that this design will be able to be commercially marketed, leading to hearing improvement for many hearing assistive device users, in time. This optimism associated with the creation of this device should not, however, be taken as overconfidence. There are a great many more studies and a great deal more research necessary before the prototype described within the current study is ready to start the manufacturing process.

REFERENCES

1. World Health Organization. Addressing the rising prevalence of hearing loss. *World Health Organization*. Published online 2018:1-40.
2. National Institute of Health. *Quick Statistics about Hearing*. U.S. Department of Health & Human Services; 2021. <https://www.nidcd.nih.gov/health/statistics/quick-statistics-hearing>
3. Fansanya B, Strong J. Younger generation safety: Hearing loss and academic performance degradation among college student headphone users. *International Conference on Applied Human Factors and Ergonomics*. 2018;1(1):522-531. doi:10.1007/978-3-319-94589-7_51
4. Mohammadpoorasl A, Hajizadeh M, Marin S, Heydari P, Ghalenoei M. Prevalence and pattern of using headphones and its relationship with hearing loss among students. *Health Scope*. 2018;8(1):65901. doi:10.5812/jhealthscope.65901
5. Brynjolfsson E, Horton J, Ozimek A, Rock D, Sharma G, TuYe H. COVID-19 and remote work: An early look at US data. *National Bureau of Economic Research*. Published online 2020:1-26. doi:10.3386/w27344
6. Leonardi P. COVID-19 and the new technologies of organizing: Digital exhaust, digital footprints, and artificial intelligence in the wake of remote work. *Journal of Management Studies*. Published online 2020. doi:10.1111/joms.12648
7. Bacher-Hicks A, Goodman J, Mulhern C. Inequality in household adaptation to schooling shocks: Covid-induced online learning engagement in real time. *Journal of Public Economics*. 2021;193(1):104345. doi:10.1016/j.jpubeco.2020.104345
8. Eggermont J. *Hearing Loss: Causes, Prevention, and Treatment*. Elsevier; 2017.
9. Dammeyer J, Lehane C, Marschark M. Use of technological aids and interpretation services among children and adults with hearing loss. *International Journal of Audiology*. 2017;56(10):740-748. doi:10.1080/14992027.2017.1325970
10. Bainbridge K, Ramachandran V. Hearing aid use among older United States adults: The National Health and Nutrition Examination Survey, 2005-2006 and 2009-2010. *Ear and Hearing Journal*. 2014;35(3):289-294. doi:10.1097/01.aud.0000441036.40169.29
11. Bennett R, Laplante-Levesque A, Meyer C, Eikelboom R. Exploring hearing aid problems: Perspectives of hearing aid owners and clinicians. *Ear and Hearing*. 2018;39(1):172-187. doi:10.1097/AUD.0000000000000477
12. Mahmoudi E, Zazove P, Meade M, McKee M. Association between hearing aid use and health care use and cost among older adults with hearing loss. *JAMA Otolaryngology- Head & Neck Surgery*. 2018;144(6):498-505. doi:10.1001/jamaoto.2018.0273
13. Punch J, Hitt R, Smith S. Hearing loss and quality of life. *Journal of Communication Disorders*. 2019;78(1):33-45. doi:10.1016/j.jcomdis.2019.01.001

14. Lesica N. Hearing aids: Limitations and opportunities. *The Hearing Journal*. 2018;71(5):43-46. doi:10.1097/01.HJ.00000533807.87095.2a
15. Wolfgang K. Artificial intelligence and machine learning: Pushing new boundaries in hearing technology. *The Hearing Journal*. 2019;72(3):26-30. doi:10.1097/01.HJ.00000554346.30951.8d
16. de Souza C, Roland P, Tucci D. *Implantable Hearing Devices*. Plural Publishing; 2017.
17. Mahboubi H, Paulick P, Kiumehr S, Merlo M, Bachman M, Djalilian H. Investigation of a novel completely-in-the-canal direct-drive hearing device: A temporal bone study. *Otology & Neurotology*. 2013;34(1):115-120. doi:10.1097/MAO.0b013e318278522e
18. Paulick P, Merlo M, Mahboubi H, Djalilian H, Bachman M. A micro-drive hearing aid: A novel non-invasive: Hearing prosthesis actuator. *Biomedical Microdevices*. 2014;16(6):915-925. doi:10.1007/s10544-014-9896-7
19. Djalilian H, Mahboubi H, Haidar Y, Paulick P, Merlo M, Bachman M. Development of a novel completely-in-the-canal direct-drive hearing device. *Laryngoscope*. 2017;127(1):932-938. doi:10.1002/lary.26221
20. Kochkin S. MarkeTrak VIII: 25-Year Trends in the Hearing Health Market. *Arch Intern Med*. Published online October 2009.
21. Agrawal Y, Platz EA, Niparko JK. Prevalence of Hearing Loss and Differences by Demographic Characteristics Among US Adults. *Arch Intern Med*. 2008;168(14):1522-1530.
22. Bagai A, Thavendiranathan P, Detsky A. Does This Patient Have Hearing Impairment. *JAMA J Am Med Assoc*. 2006;295(4).
23. BioGraphix Media. *Human Ear Anatomy*.; 2021. <http://www.biographixmedia.com/human/earanatomy.jpg>.
24. Kochkin S. MarkeTrak VII: Obstacles to adult non-user adoption of hearing aids. *Hear J*. 2007;60(4).
25. Chung K. Challenges and Recent Developments in Hearing Aids: Part II. Feedback and Occlusion Effect Reduction Strategies, Laser Shell Manufacturing Processes, and Other Signal Processing Technologies. *Trends Amplif*. 2004;8(4):125-164. doi:10.1177/108471380400800402.
26. Counter P. Implantable hearing aids. *Proc Inst Mech Eng H*. 2008;222(6):837-852.
27. Shinnars MJ, Hilton CW, Levine SC. Implantable hearing devices. *Curr Opin Otolaryngol Head Neck Surg*. 2008;16(5):416-419. doi:10.1097/MOO.0b013e32830a49f0.

28. Uziel A, Mondain M, Hagen P, Dejean F, Doucet G. Rehabilitation for high-frequency sensorineural hearing impairment in adults with the symphonix vibrant soundbridge: a comparative study. *Otol Neurotol*. 2003;24(5):775-783.
29. Hough JVD, Matthews P, Wood MW, Dyer RK. Middle ear electromagnetic semi-implantable hearing device: results of the phase II SOUNDTEC direct system clinical trial. *Otol Neurotol*. 2002;23(6):895-903.
30. Palmer C. A contemporary review of hearing aids. *Laryngoscope*. 2009;119(11):2195-2204. doi:10.1002/lary.20690.
31. NIDCD. *Fact Sheet: Hearing Aids.*; 2013.
32. NIDCD. *Fact Sheet: Hearing and Balance - Hearing Loss and Older Adults.*; 2013. doi:10.1037/e302862003-001
33. Wallhagen MI, Pettengill E, Whiteside M. Sensory Impairment in Older Adults. *Am J Nurs*. 2006;106(10).
34. *Fact Sheet: Buying a Hearing Aid.*; 2011. <https://www.entnet.org/HealthInformation/buyingHearingAid.cfm>.
35. Phonak. *Phonak - Hearing Aids Overview - Milo/Milo Plus.*; 2021. http://www.phonak.com/com/b2c/en/products/hearing_instruments/milo/overview.html.
36. Phonak. *Lyric Hearing Aids.*; 2021. <http://www.lyrichearing.com/>.
37. MS, DS, ND, SS, SW, TA. Real-world safety experience with a 24/7 hearing device. *Hear Rev*. 2011;18(1):18-23.
38. Tenholder J. *Lyric and Safety.*; 2011.
39. Beutner D, Hüttenbrink KB. Passive and active middle ear implants. *Laryngorhinootologie*. 2009;88 Suppl 1:S32-47. doi:10.1055/s-0028-1119493.
40. University of California Irvine School of Medicine Department of Otolaryngology. *Bone Anchored Hearing Aid.*; 2013. <http://www.ent.uci.edu/clinical-specialties/earsurgery/bone-anchored-hearing-aid>.
41. Banga R, Lawrence R, Reid A, McDermott A-L. Bone-anchored hearing aids versus conventional hearing aids. *Adv Otorhinolaryngol*. 2011;71:132-139. doi:10.1159/000323711.
42. Baguley DM, Bird J, Humphriss RL, T P. The evidence base for the application of contralateral bone anchored hearing aids in acquired unilateral sensorineural hearing loss in adults. *Clin Otolaryngol*. 2006;31(1):6-14. doi:10.1111/j.1749-4486.2006.01137.x.
43. *Cochlear Baha 4 Systems*.

44. Janssen O. How fairness perceptions make innovative behavior more or less stressful. *Journal of organizational behavior*. 2004;25(2):201-215. doi:10.1002/job.238
45. Lustig LR, a AH, Brackmann DE. Hearing rehabilitation using the BAHA bone-anchored hearing aid: results in 40 patients. *Otol Neurotol*. 2001;22(3):328-334.
46. McDermott A-L, Williams J, Kuo M, Reid A, Proops D. The birmingham pediatric bone-anchored hearing aid program: a 15-year experience. *Otol Neurotol*. 2009;30(2):178-183. doi:10.1097/MAO.0b013e31818b6271.
47. Mylanus E, Snik FM, Cremers RJ. Patients' Opinions of Bone-Anchored vs Conventional Hearing Aids. *Arch Otolaryngol Head Neck Surg*. 1995;121(4):421-425. doi:10.1001/archotol.1995.01890040045007.
48. Zeng F-G. Trends in cochlear implants. *Trends Amplif*. 2004;8(1):1-34.
49. Wilson BS. Cochlear implants: Current designs and future possibilities. *J Rehabil Res Dev*. 2008;45(5):695-730. doi:10.1682/JRRD.2007.10.0173.
50. Dorman M, Wilson B. The Design and Function of Cochlear Implants. *Am Sci*. 2004;92(5). doi:10.1511/2004.5.436.
51. Gray H. *Anatomy of the Human Body. Twentieth.* (Lewis WH, ed), eds.). Lea & Febiger; 1918.
52. Oticon. *Acquisition of Neurelec Brings New Capabilities in Cochlear Implants.*; 2021. <http://www.oticonmedical.com/Medical/About>
53. National Institute on Deafness and Other Communication Disorders. *Cochlear Implants*. NIH Publ No; 2013.
54. NIH Med Arts. *Ear with Cochlear Implant.*; 2021. https://www.nidcd.nih.gov/staticresources/health/images/ear_coch.jpg.
55. NIDCD. *Fact Sheet: Cochlear Implants.*; 2010. [http://report.nih.gov/NIHfactsheets/Pdfs/CochlearImplants\(NIDCD\).pdf](http://report.nih.gov/NIHfactsheets/Pdfs/CochlearImplants(NIDCD).pdf).
56. American Speech-Language-Hearing Association. *Cochlear Implant Frequently Asked Questions.*; 2021. <http://www.asha.org/public/hearing/Cochlear-Implant-Frequently-Asked-Questions/>.
57. MED-EL Corporation. *MED-EL Electrodes.*; 2021. <http://www.medel.com/us/electrodes/>.
58. CochlearTM. *Cochlear Hybrid Implant.*; 2021. <http://www.cochlear.com/wps/wcm/connect/sea/home/discover/electro-acoustic-implants/hybridssystem/implant/hybrid-implant>.

59. Wilska A. Eine Methode zur Bestimmung der Hörschwellenamplituden des Trommelfells bei verschiedenen Frequenzen. *Scand Arch Physiol.* 1935;72(161-165).
60. Truy E, Philibert B, Vesson J-F, Labassi S, Collet L. Vibrant soundbridge versus conventional hearing aid in sensorineural high-frequency hearing loss: a prospective study. *Otol Neurotol.* 2008;29(5):684-687. doi:10.1097/MAO.0b013e31817156df.
61. Yanagihara N, Honda N, Sato H, Hinohira Y. Piezoelectric semi-implantable middle-ear hearing device: Rion device E-type, long-term results. *Cochlear Implants Int.* 2004;1:186-188. doi:10.1002/cii.224.
62. Komori M, Yanagihara N, Hinohira Y, Hato N, Gyo K. Re-implant of the Rion Semi-Implantable Hearing Aid E-type. *Otolaryngol - Head Neck Surg.* 2010;143(2). doi:10.1016/j.otohns.2010.06.180.
63. Tysome M JR, R L, A J, D O 'Connor, A.F. Systematic review of middle ear implants: do they improve hearing as much as conventional hearing AIDS? *Otol Neurotol.* 2010;31(9):1369-1375. doi:10.1097/MAO.0b013e3181db716c.
64. Backous DD, Duke W. Implantable middle ear hearing devices: current state of technology and market challenges. *Curr Opin Otolaryngol Head Neck Surg.* 2006;14(5):314-318. doi:10.1097/01.moo.0000244187.66807.30.
65. Luetje C. Phase III clinical trial results with the Vibrant Soundbridge implantable middle ear hearing device: A prospective controlled multicenter study. *Otolaryngol - Head Neck Surg.* 2002;126(2):97-107. doi:10.1067/mhn.2002.122182.
66. MED-EL Corporation. *Vibrant SoundBridge Middle Ear Implant.*; 2021. <http://www.medel.com/us/vibrantsoundbridge>.
67. Mosnier I, Sterkers O, Bouccara D. Benefit of the Vibrant Soundbridge device in patients implanted for 5 to 8 years. *Ear Hear.* 2008;29(2):281-284.
68. Labassi S, Beliaeff M. Retrospective of 1000 patients implanted with a vibrant Soundbridge middle-ear implant. *Cochlear Implants Int.* 2005;1(September 1996):74-77. doi:10.1179/cim.2005.6.Supplement-1.74.
69. Colletti V, Soli SD, Carner M, Colletti L. Treatment of mixed hearing losses via implantation of a vibratory transducer on the round window. *Int J Audiol.* 2006;45(10):600-608. doi:10.1080/14992020600840903.
70. Roland PS, G S, Shea MC, Richey HS, Jones DB. Verification of improved patient outcomes with a partially implantable hearing aid. *The SOUNDTEC direct hearing system Laryngoscope.* 2001;111(10):1682-1686. doi:10.1097/00005537-200110000-00002.
71. Silverstein H, Atkins J, Thompson JH, Gilman N. Experience with the SOUNDTEC implantable hearing aid. *Otol Neurotol.* 2005;26(2):211-217.

72. Ototronix. *MAXUM Hearing Implant.*; 2021. <http://www.mymaxum.com/>.
73. Bruschini L, Forli F, Santoro A, Bruschini P, Berrettini S, Division CI. Fully implantable Otologics MET Carina TM device for the treatment of sensorineural hearing loss. In: *La protesi totalmente impiantabile Otologics MET Carina TM per il trattamento*. Vol 2009. ; :79-85.
74. Jenkins H, Niparko J, Slattery W, Neeley J, Fredeickson J. Otologics middle ear transducerTM ossicular stimulator: Performance results with varying degrees of sensorineural hearing loss. *Acta Otolaryngol*. 2004;124(4):391-394. doi:10.1080/00016480410016298.
75. Kroll K, Grant IL, Javel E. The Envoy(R) Totally Implantable Hearing System, St. *Croix Medical Trends Amplif*. 2002;6(2):73-80. doi:10.1177/108471380200600208.
76. Envoy Medical. *Esteem The Hearing Implant.*; 2021. <http://envoymedical.com/the-esteem-implant/>.
77. Chen D, Backous DD, Arriaga M. Phase 1 clinical trial results of the Envoy System: a totally implantable middle ear device for sensorineural hearing loss. *Otolaryngol Head Neck Surg*. 2004;131(6):904-916. doi:10.1016/j.otohns.2004.05.027.
78. Barbara M, Manni V, Monini S. Totally implantable middle ear device for rehabilitation of sensorineural hearing loss: preliminary experience with the Esteem, Envoy. *Acta Otolaryngol*. 2009;129(4):429-432. doi:10.1080/00016480802593505.
79. Perkins R. EarLens tympanic contact transducer: a new method of sound transduction to the human ear. *Otolaryngol Head Neck Surg*. 1996;114(6):720-728.
80. Perkins R, Fay JP, Rucker P, Rosen M, Olson L, Puria S. The EarLens system: new sound transduction methods. *Hear Res*. 2010;263(1-2):104-113. doi:10.1016/j.heares.2010.01.012.
81. Bisgaard N, Ruf S. Findings from EuroTrak Surveys from 2009 to 2015: Hearing loss prevalence, hearing aid adoption, and benefits of hearing aid use. *American Journal of Audiology*. 2017;26(3S):451-461. doi:10.1044/2017_AJA-16-0135
82. Timmer B, Hickson L, Launer S. Hearing aid use and mild hearing impairment: Learnings from Big Data. *Journal of the American Academy of Audiology*. 2017;28(8):731-741. doi:10.3766/jaaa.16104
83. Kates J, Arehart K, Anderson M, Muralimanohar R, Harvey L. Using objective metrics to measure hearing-aid performance. *Ear and Hearing Journal*. 2018;39(6):1165-1175. doi:10.1097/AUD.0000000000000574
84. Littmann V, Wu Y, Froehlich M, Powers T. Multi-center evidence of reduced listening effort using new hearing aid technology. *Hearing Review*. Published online 2017. <https://www.hearingreview.com/hearing-products/testing-equipment/testing-diagnostics->

equipment/multi-center-evidence-reduced-listening-effort-using-new-hearing-aid-technology

85. Tchorz J, Wollermann S, Husstedt H. Classification of environmental sounds for future hearing aid applications. *ESSV*. 2017;17(1):294-299. doi:http://www.essv.de/paper.php?id=253
86. Nossier S, Rizk M, Moussa N, Shehaby S. Enhanced smart hearing aid using deep neural networks. *Alexandria Engineering Journal*. 2019;58(2):539-550. doi:10.1016/j.aej.2019.05.006
87. Johnson J, Xu J, Cox R. Impact of hearing aid technology on outcomes in daily life III: Localization. *Ear and Hearing*. 2017;38(6):746-759. doi:10.1097/AUD0000000000000473
88. World Health Organization. Preferred profile for hearing-aid technology suitable for low- and middle-income countries. *WHO*. Published online 2017:1-29.
89. Theofanidis D, Fountouki A. Limitations and delimitations in the research process. *Perioperative Nursing*. 2018;7(3):155-162. doi:10.5281/zenodo.255022
90. Bin E, Andruetto C, Susilo Y, Pernestal A. The trade-off behaviours between virtual and physical activities during the first wave of the COVID-19 pandemic period. *European Transport Research Review*. 2021;13(1):14. doi:10.1186/s12544-021-00473-7
91. Roberts J, Pavlakis A, Richards M. It's more complicated than it seems: Virtual qualitative research in the COVID-19 era. *International Journal of Qualitative Methods*. 2021;20(1):1-13. doi:10.1177/16094069211002959