

UC Santa Cruz

UC Santa Cruz Electronic Theses and Dissertations

Title

A Theory of Nominal Concord

Permalink

<https://escholarship.org/uc/item/80q2t91n>

Author

Norris, Mark

Publication Date

2014

Copyright Information

This work is made available under the terms of a Creative Commons Attribution-NonCommercial-NoDerivatives License, available at <https://creativecommons.org/licenses/by-nc-nd/4.0/>

Peer reviewed|Thesis/dissertation

UNIVERSITY OF CALIFORNIA
SANTA CRUZ

A THEORY OF NOMINAL CONCORD

A dissertation submitted in partial satisfaction of the
requirements for the degree of

DOCTOR OF PHILOSOPHY

in

LINGUISTICS

by

Mark Norris

June 2014

The Dissertation of Mark Norris
is approved:

Professor Jorge Hankamer, Chair

Professor Sandra Chung

Professor James McCloskey

Dean Tyrus Miller
Vice Provost and Dean of Graduate Studies

Copyright © by
Mark Norris
2014

Table of Contents

List of Figures	vi
List of Tables	vii
Abstract	viii
Dedication	x
Acknowledgments	xi
1 Introduction	3
1.1 The main puzzle	3
1.2 Empirical Background	5
1.2.1 Grammatical sketch	6
1.2.2 Nominal morphology	8
1.2.3 Nominal morphophonology	12
1.2.4 Data sources	14
1.2.5 The case for Estonian	16
1.3 Theoretical Background	16
1.3.1 Some important syntactic assumptions	17
1.3.2 Some important morphological assumptions	20
1.4 Organization	21
2 Estonian Nominal Morphosyntax	23
2.1 Introduction	23
2.2 The DP layer in Estonian	25
2.2.1 Estonian does not exhibit properties of articleless languages	28
2.2.2 Overt material in D ⁰ in Estonian	44
2.2.3 Evidence for D ⁰ from demonstratives	50
2.2.4 Implications for the Small Nominal Hypothesis	54
2.3 Cardinal numerals in Estonian	60
2.3.1 The numeral’s “complement”	60
2.3.2 Previous analyses of numeral-noun constructions	64

2.4	Two structures for NNCs in Estonian	75
2.4.1	The size of the NP ⁺	76
2.4.2	The higher number feature in Estonian	79
2.4.3	Higher adjectives and possessors	81
2.4.4	Plural numerals in Estonian are specifiers	85
2.5	Conclusions and Further Directions	92
3	Nominal Concord in Estonian	94
3.1	Introduction: What is concord?	94
3.2	Previous approaches to concord	99
3.2.1	Comparing concord and subject-verb agreement	100
3.2.2	Agree and kinds of agreement	103
3.2.3	Adjectival concord and Agree	104
3.2.4	Possessors and intervention	120
3.2.5	Previous Approaches: Summary	122
3.3	Refining the characterization of concord	123
3.3.1	Norris 2012 on Icelandic concord: Feature Collection and Copying	124
3.3.2	Complex concord in Numeral-Noun Constructions in Estonian	128
3.3.3	Summary: Locality in numeral-noun construction concord	131
3.4	The syntactic side of concord	132
3.4.1	A theoretical argument for feature spreading	133
3.4.2	ϕ -features spread from bottom to top	135
3.4.3	Case features spread from top to bottom	148
3.5	The morphological side of concord	151
3.5.1	Agr ⁰ node insertion	152
3.5.2	Feature Copying	157
3.6	Conclusion	159
4	An Unmarked Case in Estonian Nominals	165
4.1	Introduction	165
4.2	The syntax of the pseudopartitive	168
4.2.1	Pseudopartitives in a theoretical context	170
4.2.2	N1 is a normal noun	171
4.2.3	The N2 Phrase is at least a DP	177
4.3	Case-marking in Estonian pseudopartitives	180
4.3.1	The many lives of partitive case	182
4.3.2	Accusative in Estonian grammar	184
4.3.3	Some Estonian cases are postpositions	190
4.3.4	Interim summary and implications	197
4.4	Case hierarchies and their sources	199
4.4.1	Hierarchical effects driven by morphology	204
4.4.2	Caha: case hierarchy encoded in syntactic representations	209
4.4.3	Interim summary: nominative and accusative are special	211

4.5	The Phase-Based Spell-Out approach to timing	212
4.5.1	Preliminaries on case	213
4.5.2	The Phase-Based Spell-Out analysis	214
4.5.3	Extending the analysis to numerals	218
4.5.4	Extending the analysis once more: Stacking NNCs and pseudopartitives	219
4.6	Partitive as an unmarked case inside nominals	223
4.6.1	Unmarked Partitive: the matching pattern	225
4.6.2	Unmarked Partitive: the partitive pattern	226
4.6.3	Extending the analysis to M-stacks	228
4.6.4	Summary: towards deriving the case hierarchy	231
4.7	Microvariation between Finnish and Estonian	232
4.8	Conclusions	235
5	Conclusion	238
5.1	Summary of results	238
5.2	In search of verbal concord	240
5.2.1	Verbal concord with verbal features	241
5.2.2	Verbal concord with ϕ -features	242
5.2.3	In search of verbal concord: summary	245
5.3	Next steps	246
5.3.1	Where to look for interesting data	246
5.3.2	Optional concord	247
5.4	Final remarks	249

List of Figures

1.1	The Finno-Ugric languages, slightly abbreviated (adapted from Abondolo 1998)	5
1.2	The inverted Y-Model	17
1.3	Agree between A and B resulting in feature sharing	19
3.1	Overlapping feature domains in Estonian concord	131

List of Tables

1.1	Traditional Estonian declension paradigm for <i>lind</i> ‘bird’	9
1.2	Some example stem distributions in Estonian	12
1.3	Formation of the semantic cases in Estonian	13
1.4	Formation of the short-form partitive plural in Estonian	14
2.1	Estonian declension paradigm for <i>inimene</i> ‘person’	25
2.2	Languages with and without articles (Bošković 2008)	29
2.3	Some properties of possessors in Estonian and Serbo-Croatian	43
2.4	Declension paradigms for <i>mis</i> ‘what’ and <i>miski</i> ‘something’	48
3.1	Elements showing concord in Estonian	95
3.2	A comparison of subject-verb agreement and concord	103
3.3	Partial case paradigms for ordinal numerals in Estonian	130
3.4	Some possible arrangements of categories showing concord	153
3.5	Feature expression by CEs in Estonian concord	155
3.6	An impossible pattern of feature expression in Estonian concord	155
3.7	The distribution of features in Nez Perce concord	156
3.8	The syntax and morphology of concord	160
4.1	Case patterns for the pseudopartitive <i>tükk leiba</i> ‘piece of bread’	181
4.2	Morphological case of transitive objects in Estonian	185
4.3	Finnish structural cases (Kiparsky 2001)	185
4.4	Abbreviated case paradigm for Skolt Saami <i>čüäcc</i> ‘rotten snag’ (Feist 2010:140)	186
4.5	Case patterns in Estonian pseudopartitives, to be revised again	189
4.6	Case morphology in Estonian	192
4.7	Postpositions and case markers in Estonian	195
4.8	Case patterns in Estonian pseudopartitives, final version	198

Abstract

A theory of nominal concord

by

Mark Norris

This dissertation develops a novel theory of the kind of agreement that has come to be known as (nominal) concord, traditionally described as obtaining between a noun and its modifiers, e.g., adjectives and determiners. The empirical focus is the concord system in Estonian, and thus a second goal of the dissertation is to describe and analyze various morphosyntactic puzzles within Estonian DPs. The core phenomena investigated are: (i) the functional structure of nominals in Estonian, including the category D and the syntax of cardinal numerals; (ii) number concord in Estonian and concord more generally; and (iii) case concord in simple DPs as well as case concord in pseudopartitives and DPs with numerals, which apparently show an alternation between case assignment and case concord. The dissertation argues for a view of morphological case wherein some cases are assigned in particular environments when no other case is available and for a view of nominal concord as an agreement phenomenon that is formally distinct from subject-verb agreement.

Despite the fact that Estonian lacks definite and indefinite articles—the most common members of category D—there is evidence that Estonian nominals contain a normal amount of functional structure, including DP. I argue that we achieve a clearer understanding of the Estonian possessor system if Estonian has DP, and I show that the category D is not only for articles, but also indefinite pronouns and the *wh*-determiner corresponding to ‘which’. I then argue that cardinal numerals in Estonian can occupy either a specifier position or a position as a head in the nominal extended projection. I show how this helps explain differences in number-marking and case-marking that arise in DPs with numerals.

I then turn to an analysis of nominal concord in case and number in Estonian. I argue that treating nominal concord as a DP-internal correlate of subject-verb agreement does not lead us to a better understanding of its behavior. Furthermore, I show that nominal concord exhibits some behavior that is puzzling under an Agree-based analysis: (i) adjectives show concord despite the fact that they are not in a position to c-command the source of the features, and (ii) though possessors may intervene structurally and linearly between a putative probe and goal,

they do not disrupt or affect concord in any way. The novel analysis of concord that I propose does not treat it as a direct relationship between two syntactic nodes, but as the relationship between an extended projection and the elements that comprise it. The properties just listed in (i) and (ii) are exactly what we would expect under such an approach.

Finally, I explore the alternation between partitive case assignment and case concord in pseudopartitives and DPs with numerals in Estonian. I show that the partitive case assignment pattern only obtains when the entire construction is in a position to receive nominative or accusative case. I argue against a so-called case-stacking analysis, wherein the alternating elements are assigned two cases in the syntax, with the outcome determined by the morphology. Because Estonian shows the alternation in both DPs with numerals and pseudopartitives, it poses interesting challenges to the existing analyses of superficially similar phenomena. I propose instead that partitive is unmarked case inside nominals, assigned only when no other case is available. The alternation between partitive assignment and case concord then becomes a matter of timing: nominative and accusative are assigned after the unmarked case assignment rule comes into effect, but the other cases are assigned early enough that there is no need to appeal to the unmarked case.

For my parents, Susan Hinkle Norris and the late Thomas Eugene Conner Norris.

Acknowledgments

I don't think it is possible to separate the act of writing a dissertation from the experiences one has along the way. There are so many people I want to thank for being a part of my graduate work, and I want to use many more words than I will use here. I hope that these acknowledgements can come close to communicating the wealth of support that I have received over the years.

Let me first thank Dr. Sylvia Schreiner (née Reed) for being my prom date and for telling me what linguistics was in the Spring of 2001. I didn't take my first linguistics course until 2004, when I took an Introduction to Linguistics course taught by Jill Beckman at the University of Iowa. I knew it was love when I found myself doing the practice exams not once, but twice. In addition to Jill, Bill Davies deserves special recognition for his generosity and encouragement during my time at Iowa. Their guidance, criticism, and genuine belief in me (from my perspective) has had a profound impact on me. It is safe to say that I would not have been able to come to UCSC without their influence. Thanks as well to the other linguistics faculty members I formed meaningful relationships with while I was at Iowa: Rob Chametzky and Elena Gavruseva.

The list of people to thank at UCSC is much longer. First and foremost, I want to thank the chair of my dissertation and my advisor, Jorge Hankamer. Jorge has always been extremely giving, whether as an advisor, as a colleague, or as a friend. Jorge taught my first two graduate Syntax courses, and his unwavering support and encouragement as I relearned (and in many cases, learned) about syntactic argumentation carried me through that first year. I would not have written this dissertation without the influence of the Morphology Reading Group, and the importance Jorge's presence there cannot be overstated. Thanks for always pushing me to work out the fine details of analyses, whether they are mine or somebody else's.

I have also greatly enjoyed working with the other members of my committee: Sandy Chung and Jim McCloskey. Sandy can always be counted on for honest, insightful, and critical feedback. Thanks to Jim for always helping me to see the bigger picture in every possible way. This dissertation has been pushed further in important ways from discussions with both Jim and Sandy. Thanks especially to Sandy for teaching me many new things about the pedagogy of linguistics during my last quarter at UCSC.

Beyond the committee members just mentioned, I've had the pleasure of discussing the

work herein with a number of other Santa Cruz linguists. Thanks to Amy Rose Deal (especially for Chapter 4), Karen Duek, Nick Kalivoda, Nick LaCara, Oliver Northrup, Clara Sherley-Appel, Maziar Toosarvandani, Matt Tucker, and Matt Wagers. I wish to thank members of the linguistics community at large for the same reason: Karlos Arregi, Mark Baker, Dave Embick, Claire Halpert, Heidi Harley, Peter Jenks, Line Mikkelsen, David Pesetsky, Omer Preminger, Norvin Richards, and Virve Vihman. Thank you to Vera Gribanova for always taking my work seriously, even when I was just getting started. Thank you to Ryan Bennett for the same, and also for sharing his love of pizza and tomatoes with me. I am grateful that Ruth Kramer was still at UCSC when I arrived, for both personal and professional reasons. She has graciously read almost everything I've ever written, and her feedback is always supportive and critical. Continuing the trend of both personal and professional thanks, I would be remiss if I did not thank Boris Harizanov and Anie Thompson, my cohort-mates and friends. Thanks to Boris for always encouraging me to “come on,” and thanks to Anie for unwavering support through it all (sometimes via new IM proramz [sic]).

Thanks as well to the rest of the faculty members in Linguistics at UCSC, who I have either taken classes with or served as a TA for: Judith Aissen, Pranav Anand, Adrian Brasoveanu, Donka Farkas, Junko Ito, Grant McGuire, Armin Mester, and Jaye Padgett. For administrative support and sometimes other support as well, I thank Maggie Bardacke, Debbie Belville, Tanya Honig, Ashley Hardisty, Susan Welch, and Maria Zimmer. For financial support, I thank the Institute for Humanities Research for a Summer Research Fellowship and a Dissertation-Year Fellowship, and a grant from the European Social Funds Doctoral Studies and Internationalisation Programme DoRa.

Starting a research program on Estonian meant that I had the pleasure of getting to know a number of Estonians. First, thank you those Estonians who served as consultants: Mervi Kalmus, Mirjam Kuusik, Miina Norvik, Marju Tannberg, Kärt Vahtramäe, but especially Leelo Kask and Katrin Jänese. For their friendship while I lived in Estonia, I thank Priit Keel, Külli Keel, Kärt Vahtramäe, and of course, Virve Vihman. In the Estonian way, I'll keep it brief: *Aitäh!*

Thanks to the friends who helped me take a break whenever I wanted or needed one. This includes all the people named so far, but some others as well: Angela Aiello, Nate Arnett, Taylor Bell, Kendra Buchanan, Sara Cantor, Justin Crest, Tommy Denby, Karl DeVries, Annas [sic]

Greenwood, Joel Gust, Robert Henderson, Brianna Kaufman, Shaila Kotadia, Kelsey Kraus, Jennifer Menjívar-Baumann, Adam Morgan, Jason Ostrove, Deniz Rudin, Bern Samko, Rachel Snelling-uh, Graciela Solis, Vincent D'Aloia Wagers, Toni Wilson, Lauren Winans, and Erik Zyman. Going to the gym with Oliver Northrup for the past two years has allowed me to get to know him better, and that has been wonderful. I have greatly enjoyed meeting up with Angie Wolfgang to play tennis, even if she wipes the floor with me every time. Having fellow Iowan Bridget Kemps move out to the Bay Area has been wonderful in many ways— thanks for all the “Meeps” letting me know that you’re thinking of me. My affection for Walter Bray runs very deep, but let me try to be brief: thanks for all the songs and all the laughs.

There are also friends far away whose support throughout the years has helped me carry through my time in graduate school. Thanks to Katherine Beavers, Amanda Crosby, Bobby Evers, Diana Grisanti, Kristin Lang, Lisa Raffensperger, Sean Shatto, Nicole Vespa, and Tim “Jamie” Winger. Thanks to Susan Quesal, not the least for coming to visit me and for letting me visit her. Thanks to Adam Bartelt and April Ziskovsky for always being excited for my returns to Iowa (and putting me up at their place), and thank you for coming to California to let me share Santa Cruz with you.

If I could offer one piece of unsolicited advice—and I’m pretty sure I can—it would be that everyone should try to cultivate a third space: somewhere that feels comfortable but is not home or work. For the past 1.5 years or so, my third space has been Coffeetopia on Mission Street. My working experience there has been productive and pleasant. Every word in this dissertation was either written or edited within these walls (I say *these*, because I’m there as I write this). A big part of that is due to the friendly and welcoming staff, and I wish to thank them by name: Alexis, Alia, Andrew, Chuck, Dezmen, Ed, Emily, Elle, Heidi, Joan, Katey, Leticia, Mark, Nicole, Renee, and Tiffany. Thanks to the owner, Dave, for setting up such a great space. I will be happy if my future third spaces are half as good as Coffeetopia has been.

I have been fortunate enough to have excellent housemates throughout my years in Santa Cruz. Thanks to Andy Bockus for always being willing to have a conversation or tell some jokes. Thanks to Karn/Crayon/Karen Siebald for keeping it real and keeping it real silly. Thanks to Ben Samuel for lots of stimulating conversation, genuine enjoyment of *Survivor*, and serious commitment to goofs. Thanks to Teale Fristoe for unwavering support through the years, especially for continuing to come down and see us after you moved away. Living with Yashar

Abdollahian for 6 years has brought many things to my life. I tried to express what his friendship means to me in one sentence six or seven times now, so I'll just say this: thanks/bucket.

I want to thank my family, especially my mom, for everything they have given me. Thank you for all the love and support: it means more than I can say.

Finally, for helping me get through the hard times and enjoy the good times, I want to thank Lee Hicks. Welcome to the wonderful world of linguistics! There is no way that this dissertation would have turned out the way it did without his love and support.

Abbreviations

Abbreviation	Meaning	Abbreviation	Meaning
1	first person	N	neuter gender
2	second person	NMLZ	nominalization
3	third person	NOM	nominative case
ACC	accusative case	PAR	partitive case
ADE	adessive case	PASS	passive/impersonal
ALL	allative case	PL	plural number
CAUS	causative	POSS	possessor agreement
CMPR	comparative	PRS.PCPL	present participle
COM	comitative case	PST	past tense
DA	<i>da</i> -infinitive	PST.PCPL	past participle
DAT	dative case	TRL	translative case
DEM	demonstrative	SG	singular number
DES	<i>des</i> -gerund		
ELA	elative case		
ER	agentive nominal		
F	feminine		
FEM	feminine gender		
GEN	genitive case		
IMP	imperative		
INE	inessive case		
MA	<i>ma</i> -infinitive		
M(ASC)	masculine gender		

cord is not localized to Europe. There are African languages (from at least the Bantu, Chadic, Khoisan, Niger-Congo, Nilo-Saharan, and (Ethio-)Semitic families) that show concord. There are also Amerindian languages that show concord (e.g., Algonquian, Nez Perce (Deal 2010)). This is surely an example of a phenomenon that occurs in language after language in similar (though not identical) guises.

The descriptive definition of concord (agreement with the head noun) is so self-evident when looking at examples such as those in (1) that it is easy to take concord for granted. Considering how well-known concord is, it has attracted very little theoretical attention when compared to, for example, subject-verb agreement. The goal of this dissertation is to take concord very seriously and investigate its nature very closely. Let me state at the outset that this is not a typological dissertation. Rather, I provide a thorough and explicit account of the concord system of one language: Standard Estonian. As I will show, the concord system in Estonian is rich in that most modifier types must show concord, but it can also appear quite complicated in ways that are revealing about the nature of concord. My hope is that the theory I develop here can serve as a framework for future investigation, both theoretical and descriptive, of the concord systems of the world's languages.

More broadly, the investigation of concord directly bears on current debates surrounding agreement on the one hand and morphological case on the other. With respect to agreement, much recent research has pursued the hypothesis that morphological agreement is predicated on a preexisting syntactic relationship (e.g., the relation Agree, on which see section 1.3, though this view is not endorsed by everyone. I will argue that concord should not be analyzed as the result of a syntactic Agree relationship, and in so doing, I advocate for the view that Agree and morphological agreement do not track each other one to one.

With respect to morphological case, much of the focus in recent years has been on precisely how case is assigned. Thus, one major debate concerns whether case plays a role in the narrow syntax, the morphology, or both. These questions arise because of the nature of case itself: it is morphology that seems to be connected in some way to a nominal's place in syntactic structure. The kinds of examples that raise questions for these debates are mismatches between case assignment and how that case is ultimately realized. One class of examples of this is case concord, where case is not realized once in a single DP but in several places. Another class of examples come from situations when a single constituent is ostensibly in a position to

be assigned more than one case. The investigation of nominal concord that I carry out here addresses both kinds of examples, as well as the question of what it means to be a case, both morphologically and syntactically.

This introductory chapter serves to set the backdrop for the discussion to come: §1.2 provides necessary background on Estonian, §1.3 provides a brief introduction to the theoretical assumptions as a starting point, and §1.4 provides an outline of the dissertation in its entirety.

1.2 Empirical Background

The Estonian data in this dissertation is represented in the orthography of Standard Estonian. There is some dialectal variation, but I have not encountered any crucial dialectal divides in the research I present here. Estonian is a member of the Finno-Ugric language family (see Figure 1.1) with a little over a 1,000,000 speakers, the vast majority of whom reside in Estonia.

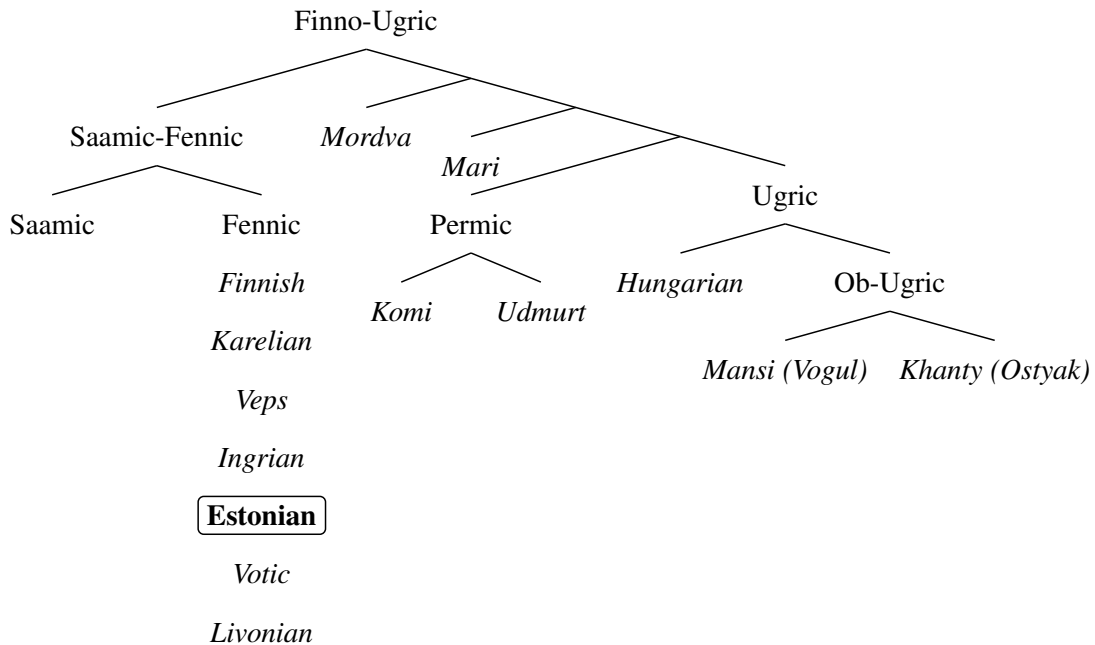

Figure 1.1: The Finno-Ugric languages, slightly abbreviated (adapted from Abondolo 1998)

Estonian is the national language of Estonia, though Russian is also spoken as a first language by roughly 30% of the population.

I represent the data in this dissertation with Standard Estonian orthography. For the most part, the orthography maps fairly transparently to IPA values. The vowels with diaereses are unsurprisingly fronted: *ä* (/æ/), *ö* (/ø/), and *ü* (/y/). Unlike Finnish, Estonian also has a mid back unrounded vowel /ɤ/, represented orthographically as *õ*. Also unlike Finnish, Estonian does not have a system of vowel harmony.

It may also be important to know that orthographic *b*, *d*, *g* are not the voiced obstruents /b/, /d/, and /g/, but the shortest versions of voiceless /p/, /t/, and /k/. Estonian is well-known within the phonological literature for its putative three-way contrast in length. This contrast is represented orthographically for the stops as *b*, *p*, and *pp* (from shortest to longest). The segments *f* (/f/), *š* (/ʃ/), and *ž* (/ʒ/) appear only in loan words.

1.2.1 Grammatical sketch

Though clausal word order is somewhat flexible, Erelt 2009 identifies two basic types of clauses, which he calls normal (SVX, see (2) and (3)) and inverted (XVS, see (4) and (5)). Much word order variation is pragmatic in nature—old information comes first, and new information comes later (Erelt 2009, Erelt, Erelt & Ross 2000).

- (2) Virve õmble-s enda-le uue seeliku.
 Virve.NOM sew-PST.3SG REFL-ALL new.GEN skirt.GEN
 ‘Virve sewed herself a new skirt.’ (Erelt et al. 2000:473)
- (3) Jaan söö-b noa-ga liha.
 Jaan.NOM eat-PRS.3SG knife-COM meat.PAR
 ‘Jaan is eating meat with a knife.’ (Erelt 2009:10)
- (4) Aia-s kasva-si-d lille-d.
 garden-INE grow-PST-3PL flower-PL.NOM
 ‘Flowers were growing in the garden.’ (Erelt 2009:7)
- (5) Jaani-l on vend.
 Jaan-ADE be.PRS.3 brother.NOM
 ‘Jaan has a brother.’ (Erelt 2009:7)

The verb can also be final or initial in some circumstances. However, since this dissertation is about nouns, I will not discuss clausal word order in detail.

Estonian is a nominative/accusative language, both in its case-marking system and verb agreement system. Transitive and intransitive subjects are marked with the same case, and tran-

sitive objects are marked with a distinct case. There are two caveats. The first caveat is that objects can be marked with one of three cases: (i) partitive case, (ii) genitive case or (iii) nominative case. Type (i) objects are traditionally called *PARTIAL OBJECTS* and objects of type (ii) and (iii) are collectively called *TOTAL OBJECTS*.

(6) Partial objects:

- a. Heiko luge-s raamatu-t.
H.NOM read-PST.3SG book-PAR
'Heiko was reading a book.'
- b. Heiko luge-s raamatu-id.
H.NOM read-PST.3SG book-PL.PAR
'Heiko was reading some books.'

(7) Total objects:

- a. Heiko luge-s raamatu läbi.
H.NOM read-PST.3SG book.GEN through
'Heiko read a/the book (and he finished it).'
- b. Heiko luge-s raamatu-d läbi.
H.NOM read-PST.3SG book-PL.NOM through
'Heiko read some/the books (and finished them).'

In (6) and (7), we see some examples of simple transitive clauses. Notice that all kinds of partial objects are marked with partitive case. For total objects, there is a number-based split in indicative transitive clauses: a plural total object is nominative, and in these clauses, a singular total object is genitive.¹ In chapter 4, I will argue that the case-marking that total objects receive is a syntactic accusative that is syncretic with genitive in the singular and nominative in the plural.

The second caveat is that, in addition to objects, some subjects can be marked with partitive case. Only some intransitive verbs allow partitive subjects.

- (8) Tānavanurga-l seisi-s inimesi.
street.corner-ADE stand-PST.3SG people.PL.PAR
'On the street corner stood some people.' (Erelt et al. 2000:470)

¹In imperatives and passives (or impersonals), all total objects are marked with nominative case. The term *total object* is descriptive; it may turn out that the optimal analysis does not treat (all) nominative total objects as actual objects.

- (9) Küla-s ela-b ukrainlasi.
 village-INE live-PRS.3SG Ukrainian.person.PL.PAR
 ‘Ukrainians live in the village.’ (Erelt et al. 2000:470)

The class of verbs allowing partitive subjects contains many verbs that would be unaccusative in other languages, and that seems like a plausible first hypothesis, but I will not pursue it here.²

The realization of agreement morphology shows many different patterns in Estonian. In affirmative declarative clauses, finite verbs obligatorily agree with nominative subjects in person and number.³ This is true even in inverted clauses, as shown in (4) and (10).

- (4) Aia-s *kasva-s / ✓kasva-si-d lille-d.
 garden-INE grow-PST.3SG / grow-PST-3PL flower-PL.NOM
 ‘Flowers grew in the garden.’ (Erelt 2009:7)

- (10) Küla-s *ela-b / ✓ela-vad ukrainlase-d.
 village-INE live-PRS.3SG / live-PRS.3PL Ukrainian.person-PL.NOM
 ‘Ukrainians live in this village.’ (Erelt et al. 2000:470)

Beyond this clause type, agreement patterns show a range of variation in patterns of exponence and agreement. I forego examples here, but at least the following possibilities of morphological agreement exponence exist: obligatory exponence (affirmative indicatives and imperatives), optional exponence (affirmative conditionals), no exponence (negated indicatives, negated conditionals) and double exponence (negated imperatives, see Norris & Thompson 2014).

1.2.2 Nominal morphology

Estonian nominals inflect for two features: number and case. There is no gender system in Estonian (even for pronouns). The number system contrasts only singular and plural. Perhaps one of the most famous facts about Estonian is that it has a sizeable case system, which traditionally

²Observe, for example, that both (8) and (9) could also be translated using *there*-insertion: *There stood some people on the street corner* and *There live Ukrainians in the village*. However, I know of at least one possible exception to this. The verb *mängima* ‘play’ can have partitive subjects.

- (i) Õue-s mängi-b lapsi.
 yard-INE play-PRS.3SG children.PL.PAR
 ‘In the yard, children played.’

To my ear, *play* does not permit *there*-insertion: **There played some children in the garden*.

³There is one exception. The modal use of *tulema* ‘come, (as a modal) need’ is invariant. It always surfaces in the third-person singular form.

contains 14 cases. A paradigm is given in Table 1.1. I will now take a moment to briefly touch

<i>Case</i>	<i>Singular</i>	<i>Plural</i>	<i>Translation</i>
NOMINATIVE	<i>lind</i>	<i>linnu-d</i>	‘(a) bird(s)’
GENITIVE	<i>linnu</i>	<i>lindu-de</i>	‘of (a) bird(s)’
PARTITIVE	<i>lindu</i>	<i>linde</i>	‘(a) bird(s)’
ILLATIVE	<i>linnu-sse</i>	<i>lindu-de-sse</i>	‘into (a) bird(s)’
INESSIVE	<i>linnu-s</i>	<i>lindu-de-s</i>	‘in (a) bird(s)’
ELATIVE	<i>linnu-st</i>	<i>lindu-de-st</i>	‘out of (a) bird(s)’
ALLATIVE	<i>linnu-le</i>	<i>lindu-de-le</i>	‘onto (a) bird(s)’
ADESSIVE	<i>linnu-l</i>	<i>lindu-de-l</i>	‘on (a) bird(s)’
ABLATIVE	<i>linnu-lt</i>	<i>lindu-de-lt</i>	‘off of (a) bird(s)’
TRANSLATIVE	<i>linnu-ks</i>	<i>lindu-de-ks</i>	‘for/into (a) bird(s)’
TERMINATIVE	<i>linnu-ni</i>	<i>lindu-de-ni</i>	‘until (a) bird(s)’
ESSIVE	<i>linnu-na</i>	<i>lindu-de-na</i>	‘as (a) bird(s)’
ABESSIVE	<i>linnu-ta</i>	<i>lindu-de-ta</i>	‘without (a) bird(s)’
COMITATIVE	<i>linnu-ga</i>	<i>lindu-de-ga</i>	‘with (a) bird(s)’

Table 1.1: Traditional Estonian declension paradigm for *lind* ‘bird’

on the uses of these cases.

1.2.2.1 The grammatical cases

The term *grammatical case* is traditionally applied to the nominative, genitive, and partitive cases. I covered some aspects of their use in marking subjects and objects in §1.2.1. Genitive is also the case assigned to prenominal possessors inside DPs.

- (11) Priidu naine on Mirjami õde.
 Priit.GEN wife.NOM be.PRS.3 Mirjam.GEN sister.NOM
 ‘Priit’s wife is Mirjam’s sister.’

In addition, partitive and genitive case are the most common cases assigned by adpositions.

- (12) a. Laps rooma-b **mööda** põranda-t.
 child.NOM crawl-PRS.3SG along floor-PAR
 ‘The child is crawling along the floor.’ (EKSS, entry for *mööda*)
- b. Laps rooma-b põranda-t **mööda** .
 child.NOM crawl-PRS.3SG floor-PAR along
 ‘The child is crawling along the floor.’ (EKSS, entry for *mööda*)

- (13) Suvila on järve ääres.
 summer.cottage.NOM be.PRS.3 lake.GEN beside
 ‘The summer cottage is beside a lake.’ (EKSS, entry for *ääres*)

I mention these two uses here as they are particularly common, but there are other uses of both the genitive and the partitive. I will explore another use of the partitive case in detail in chapter 4.

1.2.2.2 The semantic cases

The term *semantic case* is traditionally applied to the rest of the case paradigm in Estonian. I will take a moment to cover the basic use of these cases, but I note that many of these cases are also assigned by particular verbs and/or prepositions. I will not cover those uses here.

The illative, inessive, and elative case are collectively called the *interior local cases*. They indicate location or direction with respect to the referent of the case-marked DP.

- (14) a. Ema sõit-is linna / linna-sse.⁴
 mother travel-PST.3SG city.ILL / city-ILL
 ‘Mother traveled to the city.’ (Erelt et al. 2000:245)
- b. Me ole-me linna-s.
 we be-1PL city-INE
 ‘We are in the city.’ (Erelt et al. 2000:247)
- c. Tuli-n linna-st.
 come.PST-1SG city-ELA
 ‘I came from the city.’ (Erelt et al. 2000:248)

Illative indicates motion towards or into the DP, inessive indicates static location in the DP, and elative indicates motion from our out of the DP. This location is sometimes (though not always) with respect to the interior (e.g., inside) of the case-marked DP and hence they are called *interior local cases*.

The allative, adessive, and ablative cases are collectively called *exterior local cases*. They also indicate location or direction with respect to the referent of the case-marked DP.

- (15) a. Mari sõit-is välismaa-le.
 Mari travel-PST.3SG abroad-ALL
 ‘Mari traveled abroad.’ (Erelt et al. 2000:249)

⁴The form *linnasse* is strictly speaking grammatical, but most speakers would prefer the short-form illative *linna*. See section 1.2.3.2 for some brief discussion on short-form illative singulars.

- b. Mari ela-b juba kolmanda-t aasta-t välismaa-l.
 Mari live-3SG already third-PAR year-PAR abroad-ADE
 ‘Mari is already in her third year of living abroad.’ (Erelt et al. 2000:250)
- c. Mari saabu-s üleeile välismaa-lt.
 Mari arrive-PST.3SG day.before.yesterday abroad-ABL
 ‘Mari arrived from abroad the day before yesterday.’ (Erelt et al. 2000:251)

Allative indicates motion towards or onto the DP, adessive indicates static location in the DP, and ablative indicates motion from or off of the DP. This location is sometimes (though not always) with respect to the exterior (e.g., on top) of the case-marked DP and hence they are called *exterior* local cases.

Adessive case is used in a number of seemingly non-locative constructions. For space reasons, I will mention just one here: possessors in clausal possession constructions are marked with adessive case.

- (16) a. Jaani-l on vend.
 Jaan-ADE be.PRS.3 brother.NOM
 ‘Jaan has a brother.’ (Erelt 2009:7)
- b. Auto-l on neli ratas-t.
 car-ADE be.PRS.3 four.NOM wheel-PAR
 ‘The car has four wheels.’ (Erelt 2009:7)

Translative case is most often translated as ‘for’ or ‘into’. One example of its use is resultative adjectival or nominal predicates, as in (17).

- (17) Õpilane sai õpetaja-ks.
 student become.PST.3SG teacher-TRL
 ‘The student became the teacher.’

The remaining cases (terminative, essive, abessive, comitative) have fairly transparent meanings, as shown below.

- (18) Põld ulatu-s metsa-ni.
 field extend-PST.3SG forest-TER
 ‘The field extends to the forest.’ (Erelt et al. 2000:252)
- (19) Ta lama-s haige-na voodi-s.
 S/he lie-PST.3SG sick-ESS bed-INE
 ‘S/he lied sick in bed.’ (Erelt et al. 2000:252)

(20) prilli-de-ta mees
 glasses-PL-abe man
 ‘a man without glasses’ (Erelt et al. 2000:252)

(21) Mari läks Jüri-ga kinno.
 Mari go.PST.3SG Jüri-COM cinema.ILL
 ‘Mari went to the movies with Jüri.’ (Erelt et al. 2000:253)

These cases are often grouped together and called *the last four cases*.

1.2.3 Nominal morphophonology

Estonian declension paradigms exhibit complex patterns of morphophonology that should be mentioned here. This will be only a preliminary description—I will not provide an analysis of the observations in this section. I mention them here for two reasons. First, having a basic grasp of the patterns of allomorphy in Estonian nominals will be useful when looking at examples. Second, this serves as a concise but reasonably complete discussion of the core issues that future work on the morphology of Estonian nominal inflection must address. More thorough exploration can be found in Blevins 2008, Mürk 1981, 1991, 1997.

1.2.3.1 Stem gradation

There is an alternation in most declension paradigms between two stems, typically called the STRONG stem and the WEAK stem. This alternation is traditionally called GRADATION. Two examples are shown in Table 1.2. The word *lind* ‘bird’ is traditionally described as having two

CASE	SG	PL	PL.ENDING
NOM	<i>lind</i>	<i>linnu</i>	<i>-d</i>
GEN	<i>linnu</i>	<i>lindu</i>	<i>-de</i>
PAR	<i>lindu</i>	<i>linde</i>	<i>/</i>
		<i>lindu</i>	<i>-sid</i>

CASE	SG	PL	PL.ENDING
NOM	<i>kott</i>	<i>koti</i>	<i>-d</i>
GEN	<i>koti</i>	<i>kotti</i>	<i>-de</i>
PAR	<i>kotti</i>	<i>kotte</i>	<i>/</i>
		<i>kotti</i>	<i>-sid</i>

Table 1.2: Some example stem distributions in Estonian

stems: strong *lindu* and weak *linnu*. Similarly, the word *kott* ‘bag’ has two stems: strong *kotti*

and weak *koti*. The stems are clearly phonologically related, and historically, the alternations were partially or fully conditioned by phonology, but the phonological trigger has been lost in Estonian. See Mürk 1981, 1991, 1997, Prince 1980 for discussion of the variety of gradation patterns that can be seen. The singular endings are slightly irregular, but the plural endings are more regular: nominative plural is always *-d*, genitive plural is *-de/-te*, and partitive plural is *-(s)id*.

The formation of the semantic cases is much simpler: descriptively, they are based on the genitive form of the respective number, as shown in Table 1.3. So, the illative singular form of

CASE	SG	ENDING	PL	ENDING
ILL	<i>linnu</i>	<i>-sse</i>	<i>lindude</i>	<i>-sse</i>
INE	<i>linnu</i>	<i>-s</i>	<i>lindude</i>	<i>-s</i>
ELA	<i>linnu</i>	<i>-st</i>	<i>lindude</i>	<i>-st</i>
		⋮		

Table 1.3: Formation of the semantic cases in Estonian

lind ‘bird’ is a stem identical to the genitive singular *linnu* with the illative *-sse* ending. The illative plural involves the same ending *-sse* attached to a form identical to the genitive plural *lindude*.

1.2.3.2 Fusional short forms

In addition to the agglutinating forms listed above, there are forms that are typically called *short forms*. I will mention two of them there: the short illative singular and the short partitive plural. These short forms are restricted in two ways. First, not every word has a short form. Second, for some words that ostensibly have short forms, the long form may still be preferred (by some speakers).

The short illative singular has no *-sse* ending. It is formed in various ways, depending on the word in question (Erelt et al. 2000:245–247). Some examples are provided in (22).

- (22) *maja-sse* ~ *majja* / *suu-sse* ~ *suhu* / *suure-sse* ~ *suur-de*
house-ILL house.ILL / mouth-ILL mouth.ILL / big-ILL big.ILL
‘into the house’ / ‘into the mouth’ / ‘big (illative case)’

Short-form illatives may contain phonetic strings that do not otherwise exist in the language (e.g., geminate [j:] in *majja*).

There is also a short-form of the partitive plural. Some examples of short-form partitive plurals are given in (23).

- (23) lindu-sid ~ linde / seminari-sid ~ seminare
 bird-PL.PAR bird.PL.PAR / seminar-PL.PAR seminar.PL.PAR
 ‘birds’ / ‘seminars’

As with the short-form illative singulars, though both versions of the partitive plural are officially recognized in the standard grammar, they are not in equal usage for every lexical item. For example, *lindusid* sounds archaic when compared to *linde*, but *seminarisid* is still usable according to Erelt et al. (2000). The formation of the short-form partitive plural is a bit more complicated. It is traditionally characterized as based on the partitive singular form with a vowel change. There are six possibilities, shown in Table 1.4 with examples.

PAR.SG		PAR.PL	CHANGE	TRANSLATION
<i>lille</i>	→	<i>lilli</i>	<i>e</i> → <i>i</i>	‘flower’
<i>roosi</i>	→	<i>roose</i>	<i>i</i> → <i>e</i>	‘rose’
<i>laulu</i>	→	<i>laule</i>	<i>u</i> → <i>e</i>	‘song’
<i>õuna</i>	→	<i>õunu</i>	<i>a</i> → <i>u</i>	‘apple’
<i>koera</i>	→	<i>koeri</i>	<i>a</i> → <i>i</i>	‘dog’
<i>muna</i>	→	<i>mune</i>	<i>a</i> → <i>e</i>	‘egg’

Table 1.4: Formation of the short-form partitive plural in Estonian

1.2.4 Data sources

The data in this dissertation comes from three main sources: (i) the most complete descriptive grammars of Estonian (Erelt, Kasik, Metslang, Rajandi, Ross, Saari, Tael & Vare (1993a), Erelt, Kasik, Metslang, Rajandi, Ross, Saari, Tael & Vare (1993b), Erelt et al. (2000)), (ii) fieldwork conducted with Estonian speakers in the San Francisco Bay Area and Tartu, Estonia, and (iii) various sources of naturally-occurring data, including two corpora and two dictionaries:

- BALANCED: a balanced literary corpus containing equal parts journalism, fiction, and scientific writing (15 million words).
- PARLIAMENT: stenographic records from Estonian parliamentary discussions between 1995 and 2001 (13 million words).

- EKSS: *Eesti Keele Seletav Sõnaraamat* (Estonian descriptive dictionary), the largest dictionary of Estonian.
- ÕS: *Õigekeelsussõnaraamat 2013* (Estonian normative dictionary), another dictionary of Estonian.

All these resources are accessible online at <http://www.keeleveeb.ee/>.

Estonian has been well-studied by Estonian linguists, and while research within the generative tradition once flourished there, it has fallen out of favor. There is a vibrant community of researchers at the University of Tartu (*Tartu Ülikool*) and a number of linguists elsewhere in Europe as well. I rely heavily on the two-volume *Eesti keele grammatika* ‘Grammar of Estonian’ (Erelt et al. 1993a,b) as well as the shorter *Eesti Keele Käsiraamat* ‘Handbook of Estonian’ (Erelt et al. 2000). *Eesti Keele Käsiraamat* is also available online from the Eesti Keele Instituut (Estonian language institute): <http://www.eki.ee/books/ekk09/>. These grammars are written in Estonian.

In addition to the examples from those resources, some of the data here comes from primary fieldwork with Estonian speakers living in the San Francisco Bay Area as well as speakers still living in Estonia. The Estonian represented here is Standard Estonian. There is dialectal variation in Estonia, but the judgments I report here are those that were consistent among my three main consultants. Most of my consultants are from Tartu and the surrounding areas; those that are not have spent significant time there. When a source for data is not given, the data comes from my fieldwork. However, there are times when I will indicate that a particular example was volunteered by a particular consultant. I will use that consultant’s initials to indicate this.

Whenever possible, I have confirmed results from fieldwork by seeking out similar examples in the various corpora that I listed. The Descriptive dictionary of Estonian (*Eesti keele seletav sõnaraamat*, EKSS) contains both definitions and multiple examples for each entry. It has been invaluable. The normative dictionary of Estonian (*Õigekeelsussõnaraamat*, ÕS) has also been useful in that regard. Both dictionaries are hosted by the *Eesti Keele Instituut*, and examples from them are cited along with the appropriate entry. In addition, some examples come from a balanced literary corpus containing equal parts journalism, fiction, and scientific texts, and some examples come from a corpus of parliamentary speech. Estonian morphology is complicated, which can make it difficult to use string-based corpora. However, these corpora

are annotated, containing a wealth of grammatical information.

1.2.5 The case for Estonian

Estonian is a language prime for theoretical investigation. Though it has a vibrant community of linguists and a wealth of careful descriptive and typological work, Estonian has largely escaped theoretical attention. One notable exception is its phonology, notable for its putative three-way contrast in consonant and vowel length (see Prince 1980 and references there). Finnish has for its part received some attention; though Estonian is closely related to Finnish, it is also different in interesting ways. Thus, while data from Estonian itself should be brought to bear on current theoretical debates, there is also interesting microcomparative work to be done between Finnish and Estonian. My hope is that this dissertation will become part of a growing recognition and theoretical investigation of Estonian in the years to come.

1.3 Theoretical Background

The primary focus of this dissertation is the development of a theory of nominal concord, but along the way, evidence from Estonian will be brought to bear on theoretical issues concerning the relationship between the syntax and morphology of nominals. It will thus be important to fix a set of theoretical assumptions for the studies that follow. The general framework of this dissertation is the approach to syntax which has come to be known as THE MINIMALIST PROGRAM, as advanced initially by Chomsky (1995, 2000, 2001, 2008). This is paired with the approach to morphological phenomena known as DISTRIBUTED MORPHOLOGY, advanced initially by Halle (1990), Halle & Marantz (1993) and extended by much subsequent work (Embick & Noyer 2001, Embick & Marantz 2008, Embick 2010, *i.a.*).

My proposals are based on the inverted Y-model in Figure 1.2. According to this model, there are syntactic operations (MERGE, MOVE, AGREE), which build representations encoding both constituent structure and relations between constituents. At certain designated points during the course of a syntactic derivation, portions of the syntactic structure are packaged and sent to the the sound interface (Phonetic Form) and the meaning interface (Logical Form) to be further interpreted. The component of the grammar that is called MORPHOLOGY is taken to be a subcomponent of the grammar along the PF branch where morphological operations

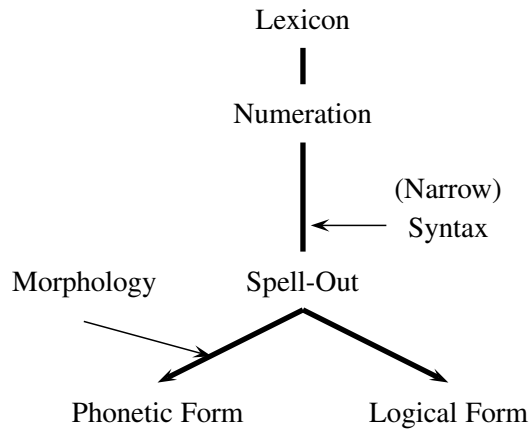
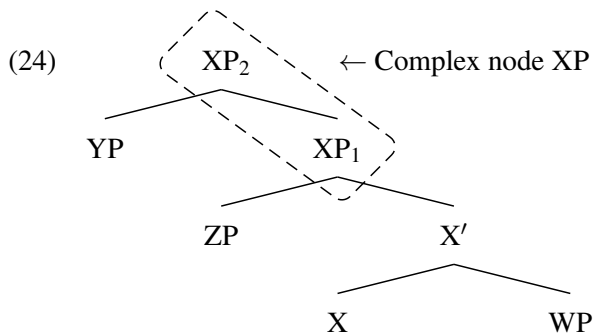

Figure 1.2: The inverted Y-Model

occur. This is the general picture, but I will now take a moment to touch on the aspects of these theories most relevant for what follows.

1.3.1 Some important syntactic assumptions

There are three phrase-structural relations which will figure into the discussion of what follows. Consider the toy representation given in (24), where traditional node labels (XP, X') are provided to aid in reading the tree.



The first relationship to note is domination. I assume that a node dominates itself as well all nodes its daughters dominate. This is a transitive relation. XP_1 thus dominates XP_1 (itself), ZP, X' , X^0 , and WP. X^0 dominates only itself.

There is one exception to the domination relation: I assume adjuncts are not dominated by their adjunction sites. This is in line with the SEGMENT THEORY OF ADJUNCTION, which

holds that adjunction does not create two separate instances of the adjunction site (XP), but it results in an expanded, more complex instance of XP (Chomsky 1986, May 1985). This complex node (in the dashed box in (24)) is made up of two *segments*, represented here as XP₁ and XP₂. Nodes that are not adjunction sites, like ZP, contain only one segment. The notion of domination that emerges is one where XP dominates YP if and only if every segment of XP dominates YP. Because one segment of XP—namely, XP₂—does not dominate YP, then XP (which spans XP₂ and XP₁) does not dominate YP.

In order to talk about relationships between adjuncts and their hosts, we must use different terminology. Instead of domination, the proper label for the relationship between XP₂ and YP is INCLUSION. A node α includes a node β if and only if β is the daughter of α or dominated by a daughter of α . Returning to (24), the segment XP₂ includes YP, because the segment YP is the daughter of XP₂. In most cases, domination and inclusion will coincide, precisely because most nodes will be made of only one segment. In the case of adjunction, they pull apart. I will make use of inclusion in Chapter 3, so it is important to note it here. The converse of inclusion is EXCLUSION. A node α excludes a node β if and only if β is not (dominated by) a daughter of α . Thus, XP₁ excludes YP. The takeaway point is that an adjunction site (or more properly, its topmost instance) *includes* its adjuncts, but it does not dominate them.

One relation defined on the basis of dominance that will be relevant is C-COMMAND. Though this relation is commonplace in syntactic research in the Minimalist Program, its definition is not always identical from one analysis to another. The definition of c-command I will assume in what follows is given in (25).

- (25) C-COMMAND: α c-commands β iff
- a. α does not dominate β
 - b. the first node which dominates α also dominates β .

With respect to (24), we can say that ZP c-commands X', X⁰, and WP.

Of the three syntactic operations Merge, Move, and Agree, the discussion in this dissertation will bear primarily on the nature of Agree. This operation is responsible for relating sets of features in the syntactic component. It is triggered by the need of some head, called a PROBE. This is generally represented by endowing the probe with an uninterpretable (sometimes called unvalued) feature that must find an interpretable counterpart in order for the derivation to converge. The element bearing these interpretable features is called the GOAL. The definition I

assume for Agree is given in (26).

- (26) A probe X establishes an Agree relation with a goal YP, where:
- a. X c-commands YP,
 - b. X lacks values for uninterpretable features that can be supplied by the values of matching features on YP,
 - c. YP lacks values for uninterpretable features that can be supplied by X,
 - d. No potential goal intervenes between X and YP,
 - e. X and YP are in the same phase.
- Agree supplies the values of each category's uninterpretable features from matching features of the other category, with the two features coalescing into a single shared feature.

The conditions in (26) are the standard set of assumptions for an Agree relation that results in Feature Sharing, following Frampton & Gutmann (2006), Pesetsky & Torrego (2007). I attempt to represent this visually in Figure 1.3 from Frampton & Gutmann (2006). There are two

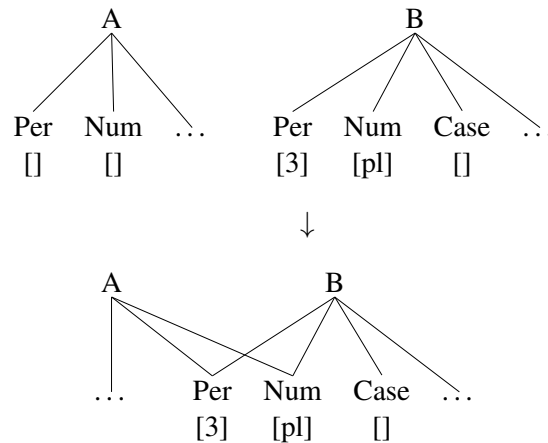

Figure 1.3: Agree between A and B resulting in feature sharing

categories, A and B, whose feature bundles include different instances of the features Per and Num (among possibly other things). The values for these features are written below in brackets. The result of Agree is shown underneath that diagram: A's and B's Num and Per features

become single Per and Num features, with their values coming from B's original values.⁵

Returning to the definition of Agree in (26), the first three conditions fix the directionality of Agree—the probe must c-command the goal—and define when it can apply. Note that (26c), called the ACTIVITY CONDITION, has been challenged on empirical grounds and is not always assumed. I present it here for completeness. The condition in (26d) is known as the INTERVENTION CONDITION. It requires that the goal that is chosen is the closest goal available, defined in terms of c-command. Finally, the condition in (26e) is the larger locality constraint, predicated on the assumption that the syntactic derivation proceeds in piece-by-piece fashion. The pieces are called PHASES. These are the portions I referred to earlier when discussing the Y-Model. It is thus Phases that are sent to the interfaces to be interpreted. After this point, phases are assumed to be opaque to further operations, and this includes Agree (26e).

1.3.2 Some important morphological assumptions

In addition to the syntactic framework outlined above, this dissertation also adopts some of the assumptions of Distributed Morphology. For this work, there are two assumptions that are most relevant: (i) the terminal nodes in syntax do not contain phonological material and (ii) syntax is the only generative engine for word-building. The first of these assumptions is sometimes known as the SEPARATION HYPOTHESIS, following Beard (1966). Under this assumption, the syntax manipulates bundles of formal features *only*. Within Distributed Morphology, the formal definition of a MORPHEME is simply a bundle of morphosyntactic features as far as the syntax is concerned.

The second assumption, that there is no generative word-builder separate from the syntax, will be strongly present in the work that follows. This means that words are not ever “built” in the lexicon, but they result from the insertion of vocabulary items into terminal nodes that have been created and manipulated first by syntactic processes. In investigations of agreement phenomena (like nominal concord), this assumption generally entails that the agreeing element will acquire the features it expresses during the derivation. This will form a part of the analysis I propose.

⁵Frampton & Gutmann (2006) propose that two unvalued features may also be part of feature sharing relationships. I do not disagree, but I have chosen not to represent such a relationship in Figure 1.3.

1.4 Organization

The dissertation is organized into three main content chapters that gradually deepen the understanding of the morphology and syntax of Estonian nominals. In chapter 2, I provide the empirical and analytical background on the syntax of nominal phrases in Estonian which serves as the starting point for the discussion in the rest of the dissertation. There are two empirical areas I focus on in this chapter. First, I address the status of the category D in Estonian, a language which lacks the lexical items most commonly associated with the head of DP: (in)definite articles. I nevertheless claim that Estonian nominals are DPs, and I claim that indefinite pronouns like *miski* ‘something’ and wh-determiners like *milline* ‘which’ occupy D⁰. I also investigate the syntax of cardinal numerals, ultimately arguing that they are involved in two constructions in Estonian. In one construction, they are heads in the nominal extended projection. In another, they are specifiers. The choice of construction leads to particular consequences for number- and case-marking in Estonian DPs.

The focus of chapter 3 is the development of a novel theory of concord. I show that concord is different in important ways from subject-verb agreement. Consequently, I argue that analyzing concord with modern theories of subject-verb agreement poses a number of difficulties. I pursue the hypothesis that concord is primarily morphological. It is not indicative of a particular syntactic relationship. Rather, in some languages, like Estonian, some categories within the DP must express number and case features in order to be well-formed words. I propose the features they express come from the closest source that has them, with closest defined in terms of *inclusion*. I propose explicit mechanisms of feature percolation that allow case, number (and in many languages, gender) features to be accessed by the elements showing concord. In the morphological component, those elements acquire the features they ultimately express. This is when the language-particular morphological requirements come into play. I show how the analysis predicts exactly the patterns of number and case concord patterns seen in Estonian DPs with numerals, where there are two number values and two case values in a single DP.

In chapter 4, I turn to a deeper investigation of the patterns of case concord in Estonian. In pseudopartitive constructions and DPs with numerals, there is an alternation between apparent (partitive) case assignment and case concord (i.e., bearing the same case value). The case concord pattern obtains in most instances. Partitive case only surfaces when the entire DP is assigned nominative case or accusative case. This is clearly a natural class: it is those cases

that are only assigned by clausal functional heads. Superficially similar phenomena in Russian and Finnish have attracted attention in recent years, and I show that those analyses cannot be easily extended to Estonian. Estonian is, to my knowledge, unique in that it shows this case-alternation pattern in DPs with numerals *and* in pseudopartitives. This allows Estonian to shed light on the way these phenomena can be analyzed. I ultimately propose that the partitive case in these situations is a morphological default, assigned to complements of nouns when they do not already have a case value. It only surfaces in nominative and accusative contexts because they are assigned later than the other cases.

Finally, in chapter 5, I sketch the picture of Estonian DP morphosyntax that emerges from the chapters and point towards directions for further research. This takes two forms. On the one hand, the proposal that nominal concord is a distinct form of agreement makes one wonder about the possibility of a verbal version of concord. I discuss several possibilities. On the other, since this dissertation focuses on a detailed analysis of concord in one language, there are some typological issues about concord that are left as open questions. I close this chapter by identifying some domains that have the potential to lead to interesting examples to further shed light on the crosslinguistic character of concord.

In the higher functional domain, the strong quantifiers *kõik* ‘all’ and *iga* ‘each’ precede demonstratives (both standard *see* and colloquial *too*). These elements together typically precede adjectives and possessors:

- (29) *kõik nee-d Kärdi punase-d auto-d*
 all DEM-PL Kärt.GEN red-PL car-PL
 ‘all these red cars of Kärt’s’
- (30) *iga see neetud riidetükk*
 each this cursed cloth.piece
 ‘each of these cursed pieces of fabric’ (BALANCED)

The order exemplified in Estonian nominals (see (31)) is common crosslinguistically, and syntactic analyses of it are plentiful (see, for example, Abels & Neeleman 2012, Cinque 2005).

(31) **Neutral order of elements in the Estonian noun phrase**

Q > Dem > Poss > Adj > N

Such accounts almost invariably make use of functional projections above the noun phrase, which have grown in number since the comparatively conservative earlier proposals made by, e.g., Abney (1987), Jackendoff (1977), Szabolcsi (1983). For example, Ritter (1991) has argued for the presence of an additional functional projection in between D^0 and N^0 —Ritter (1991) labels it Num(ber)^0 , Déchaine & Wiltschko (2002) label it ϕ^0 . The existence of such a projection is often assumed in modern investigations of nominal morphosyntax.

The nominal morphology of Estonian distinguishes two numbers and modern traditional grammars identify 14 cases in the language. These are provided in Table 2.1. There is no gender system in Estonian—the third-person singular pronoun *tema* can refer to both men and women.¹ I will look more closely at how number features are represented and manipulated in this chapter and the next chapter. A more in-depth study of the case system will be the focus of chapter 4.

The goal of this chapter will be to investigate two aspects of the morphosyntax of Estonian nominals that are not as clear-cut. This chapter is necessarily only the prelude to a detailed investigation of Estonian DPs, but it will serve as a useful basis for later chapters on concord.

¹The closest thing to an exception that I can think of is the derivational suffix *-nna*, which can attach to nationalities and some occupations to indicate a female version of that nationality/occupation (e.g., *eestla-ne* ‘Estonian person’ ~ *eestla-nna* ‘Estonian woman’, *õpetaja* ‘teacher’ ~ *õpetaja-nna* ‘female teacher’).

<i>Case</i>	<i>Singular</i>	<i>Plural</i>	<i>Translation</i>
NOMINATIVE	inimene	inimese-d	‘a person/people’
GENITIVE	inimese	inimes-te	‘of a person/people’
PARTITIVE	inimes-t	inimesi	‘a person/people’
ILLATIVE	inimese-sse	inimes-te-sse	‘into a person/people’
INESSIVE	inimese-s	inimes-te-s	‘in a person/people’
ELATIVE	inimese-st	inimes-te-st	‘out of a person/people’
ALLATIVE	inimese-le	inimes-te-le	‘onto a person/people’
ADESSIVE	inimese-l	inimes-te-l	‘on a person/people’
ABLATIVE	inimese-lt	inimes-te-lt	‘off of a person/people’
TRANSLATIVE	inimese-ks	inimes-te-ks	‘for/into a person/people’
TERMINATIVE	inimese-ni	inimes-te-ni	‘until a person/people’
ESSIVE	inimese-na	inimes-te-na	‘as a person/people’
ABESSIVE	inimese-ta	inimes-te-ta	‘without a person/people’
COMITATIVE	inimese-ga	inimes-te-ga	‘with a person/people’

Table 2.1: Estonian declension paradigm for *inimene* ‘person’

In section 2, I will address the nature of the D^0 head in Estonian, situating the language within the recent literature investigating functional structure in articleless languages. Estonian is an interesting case study, because, to the extent that the generalizations uncovered in the literature on articleless languages are robust, Estonian behaves in many ways like a language with articles. In sections 3 and 4, I turn to an investigation of cardinal numerals in Estonian, which will serve as the starting point for the next chapter’s investigation of number-marking inside Estonian nominals. I will ultimately propose that Estonian numerals can be used in two different syntactic structures, and the choice between those structures has morphosyntactic consequences.

2.2 The DP layer in Estonian

Estonian is a so-called “articleless language,” meaning (i) the language has nothing like the more familiar definite or indefinite articles from Indo-European languages, and (ii) bare nouns² have a relatively free syntactic distribution and a variety of possible semantic interpretations. They can be interpreted as indefinite, as in (32a), or definite, as in the continuation (32b).

²At the moment, the term BARE NOUN is descriptive: I do not mean to claim that these elements are simply N^0 heads as opposed to NPs. The question I am concerned with here is whether bare nouns have functional structure that is covert.

amount of functional structure. In this view, the difference between nominals in Estonian and nominals in a language like French is lexical. Estonian has a freely available D^0 with no phonological content and a particular semantics, but French does not.

Recently, the adoption of the DP Hypothesis for articleless languages has come under increased scrutiny. In particular, research by Bošković (2005, 2008, 2009) and Despić (2011, 2013, To Appear) has argued that nominals in another articleless language, Serbo-Croatian, lack a DP layer. I will refer to this analysis as the $NO-D^0$ analysis, and a representation of the Estonian nominal *jääkaru* under the $no-D^0$ analysis is given in (38).

(38) The $No-D^0$ analysis:



Under the $no-D^0$ analysis, the difference between Estonian and English is syntactic— Estonian lacks a particular functional projection that English has. We would expect this differing syntax to yield different behavior in other corners of the grammars of these languages. In fact, the main thrust of the work by Bošković and Despić is that there are indeed syntactic consequences that emerge as a result of the $no-D^0$ analysis of articleless languages. Though their work focuses on Serbo-Croatian, Bošković (2005, 2008) suggests that articleless languages may universally lack a DP layer.³

(39) **Small Nominal Hypothesis (SNH):** Nominals in all articleless languages are simply NPs (i.e., they do not project functional structure).

The two competing analyses are repeated in (37) and (38) below.

(37) The $Null-D^0$ analysis:

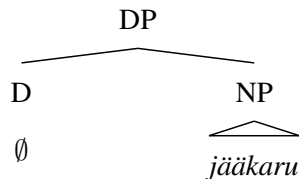

(38) The $No-D^0$ analysis:



³Bošković (2008) calls this hypothesis the ‘stronger and more interesting’ hypothesis. A weaker hypothesis would be that *some* articleless languages lack DP. Though Despić (2013) follows Bošković’s research program, he stops short of claiming that the lack of DP is universal for articleless languages, though in later work (To Appear) he states: “whether or not a language has DP crucially depends on whether or not it encodes definiteness overtly.”

In this section, I will argue in favor of a null- D^0 analysis of Estonian by way of two related explorations. First, Estonian does not show any of the properties of articleless languages outlined by the work on Serbo-Croatian. Furthermore, the claim that Estonian lacks DP would require an unmotivated analysis of possessors in Estonian. Second, though Estonian lacks clear correlates of Indo-European articles, there are indeed elements which, I will argue, occupy the D^0 position. In other words, the set of elements that can occupy D^0 is not identical to the set of elements we canonically call ‘articles’.

2.2.1 Estonian does not exhibit properties of articleless languages

The SNH is a hypothesis about the *syntax* of nominals in articleless languages, and thus, we expect there to be *syntactic* consequences for adopting the SNH for a particular language. As mentioned, the focus of the work on the NP/DP divide since Bošković (2005) has been on these posited syntactic consequences. Because it is such a strong hypothesis, the SNH makes very clear predictions about nominals in articleless languages, and indeed, it has led to an investigation of nominals in several other articleless languages.

- Russian: Pereltsvaig 2007, 2013
- Lithuanian: Gillon & Armoskaite 2012, To Appear
- Bulgarian: Dubinsky & Tasseva-Kurktchieva 2014
- West Greenlandic: Langr 2014

Here, I will explore the predictions of the SNH in Estonian, focusing on the domain of possessors. I will argue that the no- D^0 analysis of Estonian fails to illuminate any of its properties (aside from the lack of articles). What’s more, it requires unmotivated assumptions regarding the syntactic structure of possessives in the language. Thus, while a no- D^0 analysis may provide some leverage in understanding the behavior of nominals in a language like Serbo-Croatian, such an analysis of Estonian would predict a degree of similarity between nominals in the two languages. I contend that few similarities of this kind exist.

2.2.1.1 Estonian nominals can have (at least) two genitive modifiers

Bošković (2008, 2012) reveals a variety of properties that he claims are shared by many articleless languages, and he proposes that these differences come from an NP/DP distinction. A summary of the implications discussed in Bošković 2008 and applied to Estonian is given in Table 2.2.

CRITERION	ESTONIAN	CONCLUSION
Left branch extraction → NP	no Left branch extraction	—
Adjunct extraction → NP	no Adjunct Extraction	—
▶ Double genitives → DP	Yes	DP
Majority for ‘most’ → DP	Yes/unclear	DP/—
Superiority in multiple wh-fronting → DP	N/A (no MWF)	—
Negative Raising → DP	N/A (no NPIs that I know of) ⁴	—
Clitic Doubling → DP	N/A (no clitic doubling)	—
Locality in IHRCs → NP	N/A (no IHRCs)	—
Polysynthesis → NP	N/A (not polysynthetic)	—

Table 2.2: Languages with and without articles (Bošković 2008)

Note immediately that all of the criteria are structured in terms of one-way implications. For example, the criterion that inspired this work (the availability of Left Branch Extraction) is one way— if a language allows Left Branch Extraction, then it must be an NP language.⁵

⁴Estonian does have a number of elements that look like NPIs, but I have yet to find one that is clearly an NPI. For example, the word *ükski* ‘a single/any’ is only grammatical in a negated clause.

- (i) Laps *(ei) söö-nud ühtegi porgandi-t.
 child NEG eat-PST.PCPL single.PAR carrot-PAR
 ‘The child didn’t eat a single carrot (=any carrots).’

However, *ükski* can also appear in subject position of a negated clause, which is different from English NPIs (including the proposed translation of *ükski*):

- (ii) Ükski inimene *(ei) tul-nud.
 single person NEG come-PST.PCPL
 ‘Not a single person came.’

Until a deeper investigation of Estonian negative items is conducted, we cannot conclude anything from this diagnostic.

⁵The way the generalization is written, it predicts the existence of a language that lacks both LBE and the DP layer, but it is not clear to me that the analyses Bošković (2005) presents straightforwardly allow such languages. In

However, the fact that Estonian does not allow Left Branch Extraction of any kind (see (40) and (41)) does not tell us anything about the structure of its nominals:⁶

- (40) a. Heiko müü-s uue auto maha.
 H.NOM sell-PST.3SG new.ACC car.ACC PRCL
 ‘Heiko sold a/his new car.’
- b. Uue auto müü-s Heiko ___ maha.
 new.ACC car.ACC sell-PST.3SG H.NOM *t* PRCL
 ‘The new car, Heiko sold.’
- c. * Uue müü-s Heiko ___ auto maha.
 new.ACC sell-PST.3SG H.NOM *t* car.ACC PRCL
 ‘The new car, Heiko sold.’
- (41) a. Sa luge-si-d Kärdi raamatu-t.
 you read-PST-2SG Kärt.GEN book-PAR
 ‘You read Kärt’s book.’
- b. * Kelle sa luge-si-d ___ raamatu-t?
 who.GEN you read-PST-2SG *t* book-PAR
 Intended: ‘Whose book did you read?’
- c. Kelle raamatu-t sa luge-si-d ___?
 who.GEN book-PAR you read-PST-2SG *t*

the phase-based analysis, the absence of DP means the absence of a phase boundary, which obviates the need for an initial movement to a nominal escape hatch. But Bošković (2005) argues that it is precisely this movement that leads to the ban on LBE in a DP language like English, because it is too short and thus violates a principle of anti-locality. In other words, it is because of the presence of DP that LBE is not possible.

Bošković also discusses an analysis that is not rooted in phases, but on the basis of proper movement targets. He tentatively adopts the analysis of adjectives where an A^0 head takes an NP as its complement, and then he argues that LBE of that adjective is out because, on the assumption that LBE can only be phrasal movement, movement of the adjective to the exclusion of NP would not be possible. If LBE is phrasal movement, then it must be targeting at least the AP layer, but there is no way to target AP to the exclusion of NP. The only way to move the A^0 to the exclusion of the NP is if it is just the A^0 head.

Yet in a language with only NP, the AP-over-NP structure is presumably not possible, because nominal phrases would sometimes be APs and sometimes be NPs. Furthermore, it cannot be this structure that is responsible for the ban on LBE in Estonian, because this structure can be ruled out on independent grounds. Estonian adjectives can have complements of their own, which would be difficult to reconcile with a structure where they must take the NPs they modify as complements.

⁶I have glossed *maha* as PRCL because it seems to have a similar use to the other verbal particles in Estonian, such as *ära* and *läbi*. They all seem to serve a perfectivizing role, entailing that the event in question is complete. Historically, *maha* most likely comes from the word *maa* ‘earth/ground’, whose illative singular form is *maha*.

‘Whose book did you read?’

An implication that is revealing for Estonian is the possibility of having multiple genitive arguments. By genitive argument, I mean a nominal element (a DP/NP) that occurs in the noun’s functional structure and bears some semantic relation to it. These elements are sometimes the POSSESSORS of the head noun, and I will use these terms interchangeably. As noted by Willim (2000), some languages with articles allow two nominal genitive arguments, but articleless languages disallow this (see also Bošković 2008:n7).

- (42) a. Hannibals Eroberung Roms
Hannibal.GEN conquest Rome.GEN
‘Hannibal’s conquest of Rome’ (German, Bošković 2008)
- b. * podbicie Rzymu Hannibala
conquest Rome.GEN Hannibal.GEN
Intended: Hannibal’s conquest of Rome’ (Polish, Bošković 2008)

Example (42a) is grammatical with each argument of *Eroberung* ‘conquest’ in genitive case. The Polish version in (42b) is ungrammatical, regardless of word order. Bošković (2008) thus suggests that the availability of multiple genitive arguments is tied to the presence or absence of articles. If a language allows two genitive arguments, then it is a DP language.⁷

This follows straightforwardly from the no-D⁰ analysis on the assumption that the relationship between case-assigning heads and case-bearing nominals is one-to-one. If we assume that N⁰ has the ability to assign genitive case, but only once, any structure involving a nominal with two “genitive” arguments will be ruled out, because one of them will have an unvalued case feature. This is schematized in (43):

⁷Bošković (2008) restricts this diagnostic to genitive *arguments*— in his words, he excludes “possessives.” By this, I believe he intends to rule out examples such as the Polish example in (i) given by Willim (2000, p. 334).

- (i) kolekcja znaczków Piotra
collection stamps.GEN Piotr.GEN
‘Peter’s collection of stamps’

In (i), the role of *Piotra* is a “semantically-restricted Possessor.” It is possessors like this that Bošković intends to exclude.

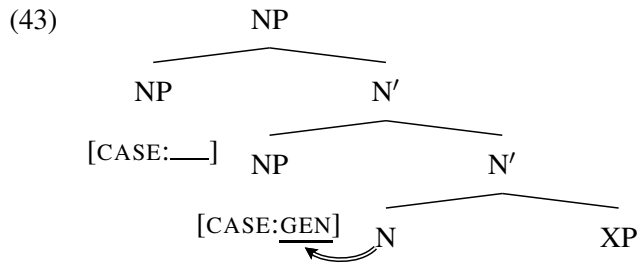

In Estonian, bare nominals can have two genitive modifiers (*pace* Erelt 2009). Examples are accepted by speakers and are also attested in corpora.⁸

(44) lapse pidev panni-de löö-mine
 child.GEN continuous.NOM pan-PL.GEN hit-NMLZ
 ‘the child’s constant banging of pans’

(45) emis-te päevane proteiini tarbi-mine
 sow-PL.GEN diurnal.NOM protein.GEN consume-NMLZ
 ‘the sows’ diurnal consumption of protein’ (BALANCED)

In each of the examples above, we have nominalizations of transitive verbs (*lööma* ‘hit’ and *tarbima* ‘consume’) with two arguments. The genitive arguments are separated by adjectives that show concord with the head noun, so we can be sure that the genitives are both arguments of the nominalization. Without an adjective, the nominalizations with two prenominal genitives (like (46)) are ambiguous.

(46) lapse panni-de löö-mine
 child.GEN pan-PL.GEN hit-NMLZ
 ‘the child’s banging of pans’ / ‘the banging of the child’s pans’

This example can be bracketed in one of two ways.

(47) [child.GEN [pan-PL.GEN hit-NMLZ]] ‘the child’s banging of pans’

(48) [[child.GEN pan-PL.GEN] hit-NMLZ] ‘the banging of the child’s pans’

⁸Erelt (2009) says this is impossible, but he provides no ungrammatical examples, and one of the sources he cites (Koptjevskaja-Tamm 1993) provides a grammatical example with two genitives.

(i) Peetr-i maja-de ehita-mine
 Peter-GEN house-PL.GEN build-NMLZ
 ‘Peter’s building of houses’ (Koptjevskaja-Tamm 1993:294)

In (47), each genitive is an argument of the nominalization. In (48), the first genitive is a possessor of the second. In (48), the two genitives are a constituent to the exclusion of the nominalization. The intervening adjective in (44) shows concord with the nominalization itself, which makes it clear that the two genitive modifiers do not form a constituent to the exclusion of the nominalization. If they did, the intervening adjective would have to show concord with one of the possessors, not the nominalization. Thus, the second kind of interpretation of (46) is not possible for (44). The genitive modifiers in (44) are both arguments of *löömine*.

If the SNH is correct for Estonian, then the examples in (44) and (45) should be impossible. Estonian is an articleless language, but this is the behavior of languages with articles. Under a DP analysis of Estonian, we could say that the extra genitive is made possible by the presence of D^0 (with one genitive presumably made available by N^0).⁹ This is represented in (49) for example (44).

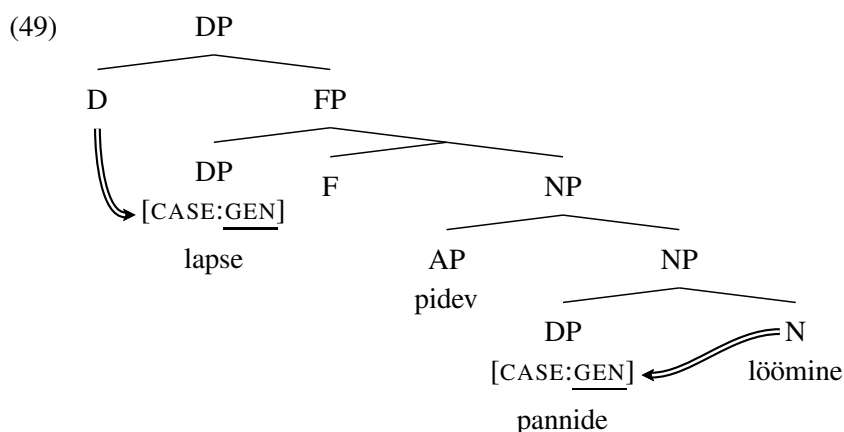

In (49), the inner DP is assigned case by the N^0 head itself. The higher possessor is introduced by a functional projection below D^0 , which assigns case to that possessor under c-command. By this diagnostic, Estonian must be a DP language.

⁹In fact, it seems that Estonian has more than two possible syntactic positions for possessors. The NP-internal position is typically more restricted than the external positions— it most readily hosts words indicating an origin, which are rendered as adjectives in many other languages, e.g., *eesti keel* ‘Estonia.GEN language’. I will not construct a complete analysis of all possessor positions in Estonian here, although we will come back to possessors in section 2.3.

2.2.1.2 Binding by possessors in Estonian

Another difference between NP languages (exemplified by Serbo-Croatian) and DP languages (exemplified by English) is discussed by Despić (2011, 2013). This difference concerns the binding possibilities of possessors of nouns in subject position. The Serbo-Croatian examples in (50) and (51) are ungrammatical, but their English translations are grammatical.

- (50) a. * Kusturicin_i najnoviji film ga_i je zaista razočarao.
 Kusturica's latest film him is really disappointed
 'Kusturica_i's latest film really disappointed him_i.'
- b. * Njegov_i najnoviji film je zaista razočarao Kusturicu_i.
 His latest film is really disappointed Kusturica
 'His_i latest film really disappointed Kusturica_i.'
- (51) a. * Jovanov_i papagaj ga_i je juče ugrizao.
 John's parrot him is yesterday bitten
 'John_i's parrot bit him_i yesterday.'
- b. * Njegov_i papagaj je juče ugrizao Jovana_i.
 John's parrot him is yesterday bitten
 'His_i parrot bit John_i yesterday.'

Despić analyzes the distinction in grammaticality by appealing to binding. The claim is that possessors in Serbo-Croatian (but not English) are capable of binding elements outside of the possessum. In each of the examples in (50) and (51), Despić claims the possessor of the subject can bind the object pronoun. Thus, if the possessor is coreferent with a following name or non-reflexive pronoun, the construction is ungrammatical (due to Condition B for (50) and Condition C for (51)). For space reasons, I will not spell out all of the details of Despić's analysis, but these are the structures the analysis is based on:

(52) English:

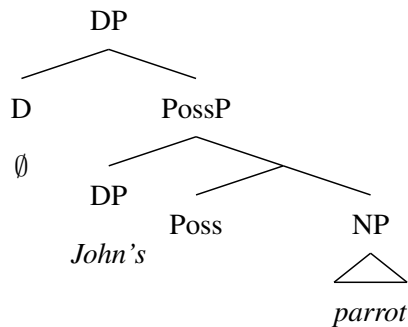

(53) Serbo-Croatian:¹⁰

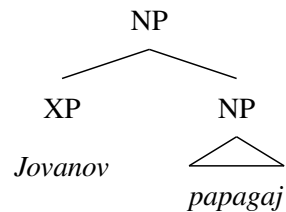

¹⁰I represent the possessor as an XP here, because it is unclear whether Despić believes they are NPs or APs—he consistently refers to them as 'adjectival', but he never explicitly says they are of category A⁰.

Despić adopts a definition of c-command whereby adjuncts to a phrase XP can c-command elements that XP itself c-commands.¹¹ Under this definition, the adjoined possessor XP in (53) c-commands everything that its adjunction site NP c-commands. More concretely, Despić’s claim is that possessors in Serbo-Croatian can c-command elements “outside of NP.” For a possessor modifying an NP in subject position, this includes any NPs lower in the structure. Despić does not provide an example of a full clausal structure in Serbo-Croatian; I sketch one possibility in (54).

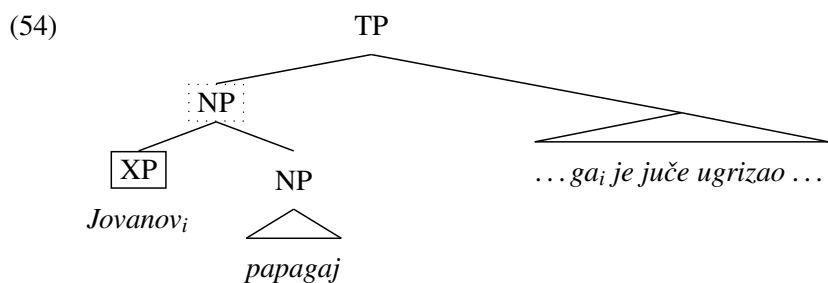

I consider it to be uncontroversial that the subject NP *Jovanov papagaj* ‘Jovan’s parrot’ (in the dotted box in (54)) c-commands the object NP *ga* ‘him’. Furthermore, under Despić’s assumptions, the XP possessor *Jovanov* (boxed in (54)) c-commands everything the possessum NP c-commands. This means that *Jovanov* c-commands the object NP *ga* ‘him’ as well. Because the object pronoun is subject to Condition B, the binding represented in (54) rules out coreference. Such examples are thus ungrammatical with the intended coreference.

In contrast, note that the structure Despić assumes for English possessors (and, I assume, possessors in DP languages more generally) buries the possessor below the DP layer.¹² As a result, while a subject DP in a language like English c-commands the object DP, the possessor of a subject DP does not.¹³ It is the proposed differences in the syntax of possessive constructions in

¹¹X c-commands Y iff X and Y are categories, X excludes Y and every category that dominates X dominates Y (X excludes Y if no segment of X dominates Y) (Despić 2013:244).

¹²The reason Despić assumes possessors are not in Spec,DP (but in Spec,PossP below DP) is that he assumes specifiers are adjuncts, following Kayne (1994). Thus, if a possessor were in Spec,DP, it would also be able to c-command elements outside of its own DP, and the contrast between English and Serbo-Croatian would require a different explanation.

¹³Though Despić does not discuss the issue, it seems that in some instances, it is possible for the possessor of the subject DP to c-command elements internal to the VP in English. For example, consider the example in (i).

(55) Every boy_i’s mother dislikes his_i friends.

English and Serbo-Croatian that Despić identifies as the heart of the grammaticality distinction between the Serbo-Croatian examples in (50) and (51) and their English translations. Thus, if examples parallel to (50) and (51) are grammatical in a given language, then Despić would presumably analyze possessive structures in that language as something close to (52). If they are not grammatical, then the language's possessive structure must be like that in (53).

Estonian appears to behave like English in this respect— sentences like those in (56) and (57) are perfectly grammatical (modulo the normal difficulties regarding backwards anaphora).¹⁴

- (56) a. Tiidu_i viimane film inspireeri-s teda_i palju.
 Tiit.GEN last film inspire-PST.3SG s/he.PAR a.lot
 'Tiit_i's last film greatly inspired him_i.'
- b. Tema_i viimane film inspireeri-s Tiitu_i palju.
 s/he.GEN last film inspire-PST.3SG Tiit.PAR a.lot
 'His_i last film greatly inspired Tiit_i.'
- (57) a. Kärdi_i koer hammusta-s teda_i.
 Kärt.GEN dog bite-PST.3SG s/he.PAR
 'Kärt_i's dog bit her_i.'
- b. Tema_i koer hammusta-s Kärti_i.
 s/he.GEN dog bite-PST.3SG Kärt.PAR
 'Her_i dog bit Kärt_i.'

Despić ties the observations about Serbo-Croatian directly to the structure of Serbo-Croatian nominals— possessors can c-command “outside of NP” as a direct result of the nominal structure in Serbo-Croatian. Based on Despić's analysis, I do not see any way that Estonian possessors could have the same structure as possessors in Serbo-Croatian yet yield different results in this empirical domain. If Despić's conclusions are correct, then proposing a structure like (53) for Estonian would predict that (56) and (57) are ungrammatical, and of course, they are not. Thus, the most natural interpretation of the data in (56) and (57) for Despić is that the

I am interested specifically in the reading where *his* covaries with *every boy*. Assuming variable binding requires c-command, the possessor *every boy* must be able to c-command the pronoun *his* in order to get the bound reading. It is not clear to me how Despić's analysis of English would allow this reading, since the difference between English and Serbo-Croatian is supposed to be that the English possessor does not c-command material in the VP. Thanks to Sandy Chung for raising this issue— see also Reinhart 1981.

¹⁴By this, I mean that my speakers at times expressed a preference for the (a) versions— the versions where the name came first— when discussing examples such as these side by side. None of my speakers suggested that the (b) examples were ill-formed.

Serbo-Croatian structure in (53) cannot be right for Estonian. One possibility is that Estonian possessors have a similar structure to English possessor as in (52).

(58) Estonian possessors (à la Despić 2013)

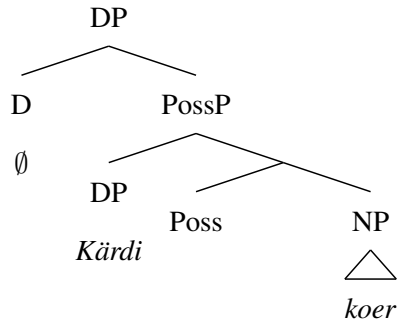

If Serbo-Croatian is held up as a typical of example of an articleless language, then this is another way in which Estonian does not behave like an articleless language.

2.2.1.3 Estonian possessors are not adjectival

A consequence of the no-D⁰ analysis proposed by Bošković (2005), Corver (1992), Despić (2013) is that demonstratives and possessors are analyzed as being syntactically close to adjectives. This descriptive statement is formalized in various ways. For Bošković (2005), following Corver (1992), possessors and demonstratives actually **are** A⁰ heads. Otherwise, they are assumed to be NP adjuncts (59) or multiple NP specifiers (60).

(59) [NP Dem [NP Poss [NP Adj [NP N]]]]

(60) [NP Dem [N''' Poss [N'' Adj [N' N]]]]

I believe this conclusion about the syntax of possessors and demonstratives to be non-standard, but Bošković (2005) argues (pp. 6–7) that it is actually a strength of the no-D⁰ analysis, as possessors are ‘adjectival’ in Serbo-Croatian based on a number of arguments. I will discuss three of them here.¹⁵

First, possessors (and demonstratives) are “morphologically adjectives,” meaning that they show concord just like adjectives, and their declensions are identical (or perhaps, very similar) to the declension of adjectives (Zlatic 1997):

¹⁵Though I focus on possessors, some of the arguments he presents are also intended to support an adjectival analysis of demonstratives.

- (61) a. Milanovim zelenim knjigama
 Milan's.FEM.PL.INSTR green.FEM.PL.INSTR books.FEM.PL.INSTR
 (Adapted from Despić 2013)
- b. Milanovih zelenih knjigama
 Milan's.FEM.PL.GEN green.FEM.PL.GEN books.FEM.PL.GEN
 (Adapted from Despić 2013)

In the examples in (61), the adjective and the possessor *Milanov* have similar endings (indicated by the underlining). The argument is that the fact that possessors show adjectival morphology and behavior (i.e., the fact that they show concord) is what we expect if possessors are A⁰ heads.

Second, possessors in Serbo-Croatian can occur in typical adjectival positions. For example, they can occur in the predicative position of a copular clause. In this way, they contrast with English, where possessive determiners cannot occur in predicative position.

- (62) Ova knjiga je moja.
 this book is my
 'This book is mine.' (cf. '*This book is my.')
- (Bošković 2005:6)

In Serbo-Croatian, the same element that is used for possession DP-internally can also be used in predicative position. This contrasts with English, where the way to express predicative possession is with words like *mine*, *yours*, and so on. If possessors are A⁰ heads, we expect them to be able to be used as adjectival predicates. In contrast, if the English possessive determiners are D⁰ heads, then it is unsurprising that they cannot occur as adjectival predicates.¹⁶

Finally, possessors in Serbo-Croatian are very small— they cannot be modified by other possessors or by adjectives.

- (63) * Moj bratov prijatelj spava.
 my.NOM brother's.NOM friend.NOM sleeps
 Intended: 'My brother's friend (=friend of my brother) sleeps.' (Bošković 2005:7)
- (64) bogati susedov konj
 rich neighbor's horse
 'rich [neighbor's horse]', *'[rich neighbor]'s horse' (Bošković 2005:7)

¹⁶It is not clear to me that we can explain this contrast on the basis of category label alone, as D(P)s (whether or not they are pronominal) are perfectly capable of being predicates in English. Thus, it cannot be that English *my* is ungrammatical in a predicative position in virtue of the category that Bošković assumes for it (i.e., D⁰).

Furthermore, the *my/mine* contrast is not isolated to predicative position. Any time a pronominal possessor occurs alone in a DP, it must be realized as the longer form (e.g., *mine*, not **my*). I will not attempt to clarify Bošković's claim further here, as Estonian does not behave like Serbo-Croatian in any case.

In (63), we see that it is not possible to have a complex prenominal possessor; the intended reading, where *my brother* is the possessor, is not possible. More generally, possessors apparently cannot even be modified by an adjective, as seen in (64). This is grammatical, but only on the absurd reading where it is the neighbor's horse who is rich. According to Bošković, the ungrammaticality of (63) and (64) follows automatically under the assumption that an adjective (i.e., the possessor) cannot be modified by another adjective.¹⁷

To recap, the no-D⁰ analysis of Serbo-Croatian leads its proponents to conclude that possessors (and demonstratives) are adjectival, because their usual positions—specifiers of higher functional material—are not present. Therefore, there is no space outside of NP for functional heads or their specifiers. If we were to adopt the no-D⁰ analysis of Estonian in line with the SNH, a specifier analysis of possessors and demonstratives would likewise not be possible. There are thus two basic analytical options for prenominal possessors under a no-D⁰ analysis of Estonian. Either they are adjunct or complement PPs, as in Romance languages (Giorgi & Longobardi 1991)—an option not considered in the work on Serbo-Croatian—or they must be analyzed in the same way as possessors in Serbo-Croatian.

I will not provide a detailed analysis of PPs in Estonian, but there is at least one *prima facie* difference between PPs that I take to be complements and DP-internal possessors in Estonian. First, observe that possessors must precede the noun they modify.

(65) Jaani auto / *auto Jaani
 Jaan.GEN car.NOM / car.NOM Jaan.GEN
 'Jaan's car'

(66) aken-de pese-mine / *pese-mine aken-de
 window-PL.GEN wash-NMLZ / wash-NMLZ window-PL.GEN
 'washing of windows'

It is ungrammatical for DP-internal possessors to follow the possessum. Now, observe that PPs that look like complements show the reverse behavior of possessors in that they can only *follow* the noun.

(67) tagatis edu-ks / *edu-ks tagatis
 guarantee.NOM success-TRL / success-TRL guarantee.NOM
 'key to success'

Erelt (2009)

¹⁷For a different explanation of the observation that possessors cannot be modified, see Harizanov (2014).

- (68) uks eluruumi-de-sse / *eluruumi-de-sse uks
 door living.quarter-PL-ILL / living.quarter-PL-ILL door
 ‘door to the living quarters’

I take this observation as evidence that possessors and PP complements like the elements in (67) and (68) should not be given the same analysis.¹⁸

If, on the other hand, possessors and demonstratives are analyzed in the same way in Estonian as in Serbo-Croatian, then all else being equal, we would predict that possessors in Estonian would have roughly the same behavior as possessors in Serbo-Croatian. For example, we predict them to show adjectival morphology (and concord), to serve as predicates, and we might expect them to be very small (i.e., unmodifiable).

But that is not what we find. Possessors in Estonian do not display any of those properties. For starters, possessors in Estonian are one of the only elements that do not show concord with the possessed noun.

- (69) a. Kõigi-l Kärdi(*1) rikas-te-l sõpra-de-l on auto-d.
 all.PL-ADE Kärt.GEN(*ADE) rich-PL-ADE friend-PL-ADE be car-PL.NOM
 ‘All of Kärt’s rich friends have cars.’
- b. Kõigi-l mu(*1) rikas-te-l sõpra-de-l on auto-d.
 all.PL-ADE my.GEN(*ADE) rich-PL-ADE friend-PL-ADE be car-PL.NOM
 ‘All of my rich friends have cars.’

In (69), the quantifier *kõigil* ‘all’ and the adjective *rikastel* ‘rich’ are marked for plural number and adessive case— apparently in agreement with the head noun *sõpradel* ‘friends’. The possessors *Kärdi* ‘Kärt’s’ and *mu* ‘my’ are marked only for singular number and genitive case— no trace of plurality nor adessive case. I will propose a formal analysis of concord in the following chapters. For now, I simply note that possessors in Estonian are morphologically different from adjectives, both in form and in their behavior with respect to concord.

Second, possessors in Estonian cannot be predicates in copular clauses. This is again different from Serbo-Croatian. In order to express a possessive meaning in a copular clause, the word *oma* ‘own’ is required, as we can see in (70).

¹⁸The behavior of adjunct PPs is less clear to me at present. Some appear to permit both orders (e.g., *noka-ga müts ~ müts noka-ga* ((bill-COM) hat (bill-COM)) ‘hat with a bill’, but others seem to appear only before the noun (e.g., *puu-st maja ~ ??maja puu-st* ((wood-ELA) house (??wood-ELA)) ‘wooden house’. Before we can rule out a PP analysis of Estonian possessors, we need to have a better understanding of the behavior of adjunct PPs.

- (70) a. See auto on Kärdi *(oma).
 this.NOM car.NOM be Kärt.GEN own
 ‘This car is Kärt’s.’
- b. See auto on minu *(oma).
 this.NOM car.NOM be 1SG.GEN own
 ‘This car is mine.’

I will not attempt an analysis of Estonian predicative possession here, but I believe its use is connected to the possessor’s dependence on a more articulated nominal spine in Estonian.¹⁹ In other words, Possessors in Estonian are not adjectives that can either modify nouns or stand alone as predicates. To be sure, Estonian adjectives can and do occur in the predicative position of a copular clause:

- (71) a. See toonekurg on pikk.
 this.SG.NOM stork be.3 tall.NOM
 ‘This stork is tall.’
- b. Mu jälgratta-d on punase-d.
 1SG.GEN bicycle-PL.NOM be.3 red-PL.NOM
 ‘My bicycles are red.’

The ability to appear in predicative position (in isolation) is thus another difference between Estonian possessors and Serbo-Croatian possessors. It is another way in which Estonian possessors fail to show adjectival behavior in the sense discussed by Bošković.

Finally, recall that possessors in Serbo-Croatian cannot be modified in any way. They cannot be modified by an adjective (64), and recursive possessive structures are not allowed (63). In Estonian, both modification (72) and recursion (73) are possible and commonplace.

- (72) ... sest ta kaitse-b laia-s mõtte-s [kõigi töötaja-te]
 because s/he protect-3SG broad-INE thought-INE all.PL.GEN worker-PL.GEN
 huve.
 interest.PL.PAR
 ‘... because s/he is advocating, in a broad sense, for the interests of all workers.’
 (PARLIAMENT)

¹⁹Note that this sounds quite similar to the contexts of use for the English *my* vs. *mine* (see fn. 16) in that *my* is used when the head noun is present, and *mine* is used otherwise.

- (73) [[[*kehakultuuri* ja *spordi*] *uuri-mise*] *laboratooriumi*]
 physical.education.GEN and sport.GEN study-NMLZ.GEN laboratory.GEN
juhataja
 director
 ‘the director of the laboratory for the study of sports and physical education’
 (BALANCED)

In (72), the possessor *kõigi töötajate* ‘all workers’ contains the quantifier *kõik*, which is one of the highest elements in the Estonian nominal extended projection; simple adjectival modification is also possible, as in *rikka mehe hobune* ‘rich.GEN man.GEN horse.NOM’, which cannot be about a rich horse (unlike the Serbo-Croatian example, which *must* be about a rich horse). In (73), we see a corpus example of possessor recursion in Estonian. The various possessors and possessa are broken down in (74).²⁰

	<i>kehakultuuri ja spordi</i>	<i>uurimise</i>	<i>laboratooriumi</i>	<i>juhataja</i>
	physical education and sport	study	laboratory	director
(74)	POSSessor	POSSESSUM	—	—
	POSSessor		POSSESSUM	—
	POSSessor			POSSESSUM

This example is typical in Estonian— many things that would be *of*-complements in English are rendered as possessors in Estonian.

In sum, Estonian possessors behave differently from Serbo-Croatian possessors with respect to all three of the ‘adjectival’ properties discussed here, as summarized in Table 2.3.²¹ If those properties are to be tied to their syntax, as Bošković’s argumentation suggests, then it would be difficult to argue that the syntax of possessors in Estonian mirrors the syntax of possessors in Serbo-Croatian as would be required for a no-D⁰ analysis of Estonian nominals.

Instead, I propose that possessors in Estonian are normal DPs. This immediately predicts that they should have the same range of modification possibilities as normal nouns, and it seems

²⁰This just one of many possible bracketings for the DP in (73), but some of them are nonsensical (e.g., the director of [the sports study laboratory] and [physical education]). Another reasonable bracketing would involve ‘physical education’ coordinated with ‘[[sports] study]’ rather than with ‘sports’ alone.

²¹Bošković (2005) cites two other pieces of evidence for the “D⁰-as-A⁰” analysis of possessors and demonstratives. First, they can co-occur (unlike in English, where both **this my dog* and **my this dog* are ungrammatical). Bošković ties this to the fact that adjectives can be iterated. Second, the ordering between adjectives and possessors is “freer” than in English. I do not believe either of these facts would require an adjectival analysis of possessors or demonstratives, so I do not discuss them here.

	ESTONIAN	SERBO-CROATIAN
CONCORD?	No	Yes
PREDICATES?	No	Yes
MODIFIABLE?	Yes	No

Table 2.3: Some properties of possessors in Estonian and Serbo-Croatian

that they do ((72)-(73)). As sketched before, possessors are introduced by a functional projection above NP, though some nouns (e.g., nominalizations) can also license a possessor in their own specifier. It is too terse to say that possessors in Estonian “do not show concord.” They do show concord, but it is concord *internal to the possessor DP* rather than concord with the head noun. This is exactly what we expect if possessors are full nominal extended projections.

2.2.1.4 Summary: Against a no-D⁰ analysis of Estonian

Thus far, I have considered the prospects for no-D⁰ analysis of Estonian nominals by way of investigating possessors in Estonian. I began by showing some of the properties that Bošković (2008) claims can be correlated with an NP/DP distinction in a language’s nominals. Most of them do not tell us anything about Estonian, either (i) because Estonian does not have constructions of the relevant type, or (ii) because the implication is written in such a way that the fact that Estonian patterns in a particular way is not revealing. Yet, Estonian does allow multiple genitive arguments for one nominal, and that is DP behavior according to Bošković (2008).

I then turned to an investigation of the syntax of possessors in Estonian, with a particular focus on the conclusions that would be forced by the no-D⁰ analysis. What we saw is that the possessors in Estonian are quite different from possessors in Serbo-Croatian, the language that Bošković and Despić analyze as being a clear case in favor of the no-D⁰ analysis. It would be puzzling if possessors in the two languages had the same syntax yet behaved so differently.

I conclude that the null-D⁰ hypothesis is the more promising analysis of Estonian nominals. Thus, the lexicon of Estonian contains at least one null element of category D⁰, with the kind of semantics you would expect from an element of category D⁰ (i.e., identification/domain restriction).²² So, instead of having overt articles like *the* or *a*, Estonian has silence. However, that does not mean that Estonian does not have overt D⁰ heads. There are other elements that

²²I will not discuss the semantics of bare nominals in articleless languages. See Dayal (2004) for discussion of some of the relevant issues.

have been argued to occupy the D^0 position in other languages. Once we widen the category beyond articles, we find at least a couple of functional elements which, I will argue, can occupy the D^0 position.

2.2.2 Overt material in D^0 in Estonian

The traditional category of determiners was a broad class, including demonstratives, quantifiers, cardinal numerals, wh-determiners like the word *which*, articles, and pronouns (among possibly others). Even before the work of Abney (1987), Szabolcsi (1983, 1994), it was noted that these elements did not all occupy the same position (e.g., Jackendoff 1977, Perlmutter 1970). Since then, research on the internal syntax of nominals has been taken more seriously, resulting in an expansion of functional categories and a more nuanced view of “Determiners.” Concretely, there are some elements that were analyzed as exponents of $D(et)^0$ that are commonly assumed to occupy different positions:

- **Quantifiers** are often argued to occupy a separate projection above DP: Q^0 (Matthewson 2001).
- **Demonstratives** are argued to occupy a specifier position: Spec,DP (Harizanov 2011, Kramer 2009), something lower (Deal 2010), or generated lower and then moved to Spec,DP (Alexiadou, Haegeman & Stavrou 2007, Giusti 1997).
- **Cardinal numerals** occupy a lower position: Spec,NumP (Danon 2012, Deal 2013a, Longobardi 2001, Watanabe 2006) or a head position, e.g., Num^0 (Danon 2012, Ionin & Matushansky 2006, Nelson & Toivonen 2000, Ritter 1991)

This leaves us with articles, pronouns, and wh-determiners like *which* as elements that may occupy D^0 . Though Estonian lacks articles, it does have elements which have been argued/assumed to occupy D^0 in other languages. I will now turn to a discussion of these examples, showing that all provide evidence of a distinct functional position above NP, which I will propose is D^0 . I will begin discussion with the Estonian indefinite pronouns and then discuss Estonian wh-determiners.

2.2.2.1 Estonian indefinite pronouns

The examples in (75) and (76) exemplify Estonian's version of what has come to be called the INDEFINITE PRONOUN CONSTRUCTION.

- (75) a. midagi huvitava-t
something.PAR interesting-PAR
'something interesting'
- b. * huvitava-t midagi
interesting-PAR something.PAR
- (76) a. keegi uus
somebody new
'somebody/someone new'
- b. * uus keegi
new somebody

The typical examples involve the the words *miski* 'something' and *keegi* 'someone' modified by an adjective. I will call *miski* and *keegi* INDEFINITE PRONOUNS following work on their English translations as well as the term from traditional Estonian grammars Erelt et al. (1993b, 2000). Though I will focus on examples involving adjectives, note that *miski* and *keegi* can appear in isolation, just like their English correlates. Note that the adjective must follow the indefinite pronoun—the same is true for their English translations. And, just as in English, adjectives in Estonian typically precede the nouns they modify.

- (77) a. huvitav raamat
interesting book
'a/the interesting book'
- b. * raamat huvitav
book interesting

The classic (and to my mind, the simplest) analysis of these facts is that the indefinite pronoun does not occupy the same (surface) position as a normal noun. This could be accomplished via base generation of indefinite pronouns in a higher position (Larson & Marušič 2004) or by moving the indefinite pronoun from a lower position to a higher functional projection, moving “around” the adjective in the process (Abney 1987, Kishimoto 2000). These are represented for the construction in Estonian in (78a) and (78b) respectively.²³

²³Kishimoto (2000) assumes a more articulated nominal structure, where there is a Num⁰ projection in between NP and DP. He proposes that indefinite pronoun constructions in English involve movement to Num⁰, not D⁰.

(78) a. Base-generation:

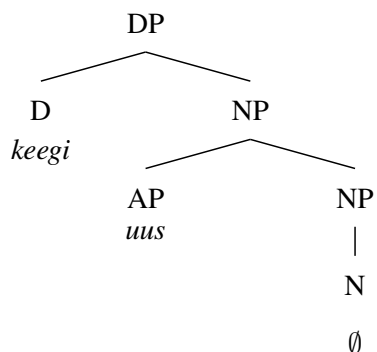

b. Movement:

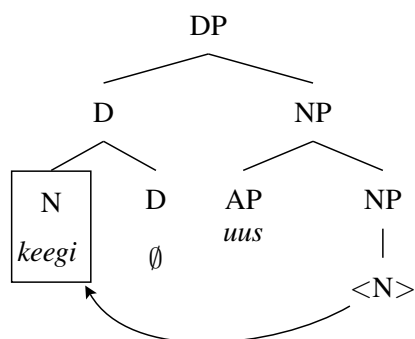

In either case, the surface position of the indefinite pronoun is higher than N^0 , and we have a clear explanation of the adjective ordering asymmetry: in Estonian, adjectives are ordered before nouns and after functional elements higher in the nominal extended projection. To put it briefly: higher elements typically linearize to the left in Estonian. There is one straightforward argument against generating the indefinite pronouns as N^0 s (as in (78b)): indefinite pronouns can co-occur with an overt noun.

(79) Laua all on miski kleepuv asi.
 table.GEN under be something sticky thing
 ‘There is a sticky thing under the table.’ (Nemvalts 1996:p. 59)

(80) Keegi mees astu-s sisse.
 someone man step-PST.3SG in
 ‘Some man entered.’ (EKSS, entry for *keegi*)

The noun is optional in both (79) and (80) (although (80) would clearly mean something different if *mees* ‘man’ were absent), but it can be present. Thus, we have evidence for a higher position in Estonian nominals, occupied by indefinite pronouns.

<i>case</i>	<i>wh-pronoun</i>	<i>indefinite pronoun</i>
NOM	mis	mis- ki
GEN	mille	mille- gi
PAR	mida	mida- gi
ILL	mille-sse	mille-sse- gi
INE	mille-s	mille-s- ki
ELA	mille-st	mille-st- ki
ALL	mille-le	mille-le- gi
ADE	mille-l	mille-l- gi
ABL	mille-lt	mille-lt- gi
TRL	mille-ks	mille-ks- ki
TER	mille-ni	mille-ni- gi
ESS	mille-na	mille-na- gi
ABE	mille-ta	mille-ta- gi
COM	mille-ga	mille-ga- gi

Table 2.4: Declension paradigms for *mis* ‘what’ and *miski* ‘something’

This unified analysis posits the existence of not one, but two functional projections above NP. I argued that at least one position was necessary on the basis of the fact that the indefinite pronouns can co-occur with a noun; it seems these pronouns are not generated in N^0 , but must be generated higher. In my analysis of indefinite pronouns, I proposed that *-gi* be syntactically separated from the *wh*-pronoun inside. This requires yet an additional syntactic position, but it allows for a unified syntactic analysis of indefinite pronouns and *wh*-pronouns. It also provides a very straightforward way to understand the morphology of indefinite pronouns, as they look like *wh*-pronouns with *-gi* on the outside.

I proposed that indefinite pronouns end up in D^0 , but they do not start there. Let us now consider some examples of elements that simply are D^0 heads.

2.2.2.2 Estonian *wh*-determiners are in D^0

The English words *which* and *what* as in (82) are often assumed to be in D^0 (Abney 1987):

- (82) a. [Which/what man] did you see at the store?
b. I wondered [what/which vase] he broke.

They certainly seem to serve one of the syntactico-semantic functions of determiners in English in that their presence is enough to license the use of a singular count noun. They are ‘*wh*’

because the DPs they head undergo wh-movement just like a wh-pronoun. Estonian also has wh-determiners of this sort:²⁸

- (83) a. ... [**mis** töö-le] ta nüüdse-ks on läinud.
 what work-ALL he current-TRL be.3 gone
 ‘(Can you tell me) [to **what** job] he has gone for the moment? (PARLIAMENT)
- b. Kelle poolt ning [**mis** asjaolu-de-l] loo-di
 who.GEN by and what circumstance-PL-ADE create-PASS.PST
 teksti-d?
 text-PL.NOM
 ‘By whom and [in which circumstances] were the texts created?’ (BALANCED)
- (84) a. **Millise-d** panga-d hakka-vad laene and-ma?
 which-PL.NOM bank-PL.NOM start-3PL loan.PL.PAR give-MA
 ‘Which banks will be giving out loans?’ (PARLIAMENT)
- b. **Millise-s** seriaali-s ta mängi-b?
 which-INE series-INE he play-3SG
 ‘Which series is he in?’ (BALANCED)

Just like indefinite pronouns, the wh-determiners *milline* and *mis* precede the head noun. I propose that they, too, are located in D⁰— in line with the assumed analysis for English (Abney 1987) as well as Szabolcsi’s (1994) analysis of Hungarian. Since there is no indefinite pronoun with *milline* as a base (**millinegi*), the simplest account would be to propose that *milline* and wh-determiner *mis* are generated as D⁰ heads. Thus, the DPs in (83a) and (84a) have at least the following syntactic structure:²⁹

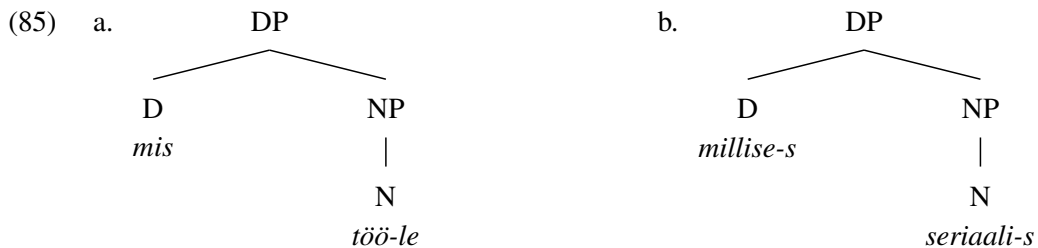

²⁸Interestingly, *mis* as a wh-determiner does not inflect. Erelt et al. (2000) suggest it may be a truncation of *missugune* ‘what kind’, in which the *mis* morpheme is invariant. Equivalently, we might say that wh-determiner *mis* and wh-pronoun *mis* are distinct lexical items. This might also open up a possible line of attack for understanding the fact that there is no *kes* wh-determiner.

²⁹I simply represent the terminal nodes in these trees as they are in the examples— I do not intend to convey that I believe the case feature on a noun is generated in N⁰ with the noun.

- (88) iga see neetud riidetükk
 each this cursed cloth.piece
 ‘each of these cursed pieces of fabric’ (BALANCED)

However, in certain circumstances, demonstratives or possessors can come before strong quantifiers.

- (89) Demonstratives before Q⁰:
- a. Tea-des ne-id kõiki keerukus-i, ...
 know-DES DEM-PL.PAR all.PL.PAR complication-PL.PAR
 ‘Knowing all these complications, ...’ (PARLIAMENT)
- b. nee-d kõik ettevõtte-d
 DEM-PL.NOM all.NOM company-PL.NOM
 ‘all those companies’ (BALANCED)

- (90) Possessors before Q⁰:
- a. Kärdi kõik poja-d käi-vad kooli-s.
 Kärt.GEN all.NOM son-PL.NOM go-3PL school-INE
 ‘All of Kärt’s sons go to school.’ (LK, Volunteered)
- b. selline akt, [mille iga paragrahvi] kohta on palju
 the.kind act whose.GEN each.GEN paragraph.GEN about be many
 eriarvamusi.
 dissent.PL.PAR
 ‘the kind of act for which there are many differing opinions about every paragraph.’ (PARLIAMENT)

Whereas normally *kõik* ‘all’ or *iga* ‘each’ is first within the DP, in (89) we find the demonstrative *see* (plural *need*) coming first, and in (90) we find possessors: in (90a), it is a normal DP possessor, and in (90b), the possessor is a wh-pronoun. Interestingly, for wh-pronoun possessors, the possessor cannot remain *in situ*. It must appear on the left edge of the nominal.

- (91) a. * Kõik kelle poja-d käi-vad kooli-s?
 all.NOM who.GEN son-PL.NOM go-3PL school-INE
 Intended: ‘All of whose children go to school?’
- b. Kelle kõik poja-d käi-vad kooli-s?
 who.GEN all.NOM son-PL.NOM go-3PL school-INE
- (92) a. * Kõik mille jala-d oli-d sinise-ks värvi-tud?
 all.NOM what.GEN leg-PL.NOM be.PST-3PL blue-TRL paint-PASS.PST.PCPL
 Intended: ‘All of what thing’s legs were painted blue?’

- b. Mille kõik jala-d oli-d sinise-ks värvi-tud?
 what.GEN all.NOM leg-PL.NOM be.PST-3PL blue-TRL paint-PASS.PST.PCPL

The examples so far use the wh-pronouns *kes* and *mis*. Note that the displaced possessors can be syntactically complex, as the following examples using the wh-D⁰ *milline* ‘which’ show.

- (93) **Millise võistleja** kõik medali-d ripu-vad
 which.GEN competitor.GEN all.PL.NOM medal-PL.NOM hang-PRS.3PL
 spordimuuseumi-s?
 sports.museum-INE
 ‘All of which competitor’s medals are hanging in the sports museum?’
- (94) **Millise helilooja** kõiki sümfoonia-id hoit-akse
 which.GEN composer.GEN all.PL.PAR symphony-PL.PAR keep-PRS.PASS
 ülikooli raamatukogu-s?
 university.GEN library-INE
 ‘All of which composer’s symphonies are kept in the university library?’

Unlike the examples we have seen so far, the possessors in (93) and (94) are not simultaneously minimal and maximal. They are clearly phrases. Thus, we have two kinds of elements that can apparently be displaced to the initial position in Estonian nominals, and this must be a position to which phrases may move.

It seems to me that the simplest analysis is that the fronting of demonstratives and possessors is the same (the same proposal for similar data in Modern Greek is discussed in Alexiadou et al. 2007, Horrocks & Stavrou 1987). The fact that phrases can move to this position (see (93) and (94)) suggests that this is not a higher head position, as full phrases do not typically raise to head positions. The fact that this is the position of wh-phrases suggests to me that the position to the left of *kõik* and *iga* is an A'-position (i.e., the ‘edge’ of DP). For non-wh-elements, I assume this movement is focus-based (see Horrocks & Stavrou 1987), although the precise pragmatics constricting its use are still unclear to me. Analytically, we could say that *kõik* and *iga* are D⁰ heads and this is Spec,DP, or they are Q⁰ heads (*à la* Matthewson 2001) and this is Spec,QP. This analysis is represented in (95).

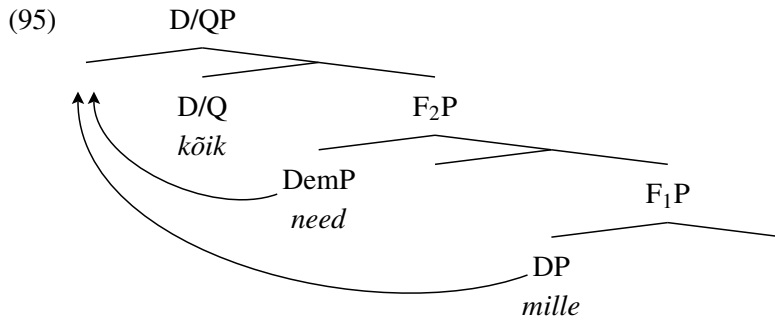

This analysis unifies the fronting of demonstratives and possessors, but it assumes that this is phrasal movement, which in turn requires that the demonstrative be phrasal in Estonian.

Under an analysis where demonstratives are D^0 heads, we could of course maintain the analysis of possessor fronting: A' -movement of a phrasal element to the edge of DP. However, the fronting of demonstratives would have to be different if demonstratives are heads. Heads do not typically move to phrasal positions (but see Matushansky 2006 for an exception). Unless a head can move to a phrasal (A') position, this analysis would require that demonstratives are phrasal. We can certainly drive the right word order if D^0 undergoes head movement to Q^0 —we would just need to make the proper statements about how complex heads in Estonian are linearized.

(96) Alternative: demonstrative fronting as head movement

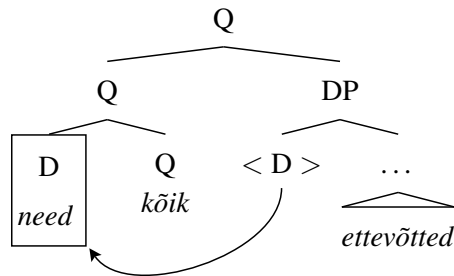

Note that treating demonstrative fronting as head movement would preclude the possibility of a unified analysis of possessor fronting and demonstrative fronting. Possessor fronting can involve full phrases, which makes a head-movement analysis of it unlikely. Given that first impressions suggest similar motivations for the possessor fronting and demonstrative fronting, it seems that the null hypothesis is that they are the same.

More strongly, it is not clear to me how a head movement analysis allows us to understand the phenomenon at hand. First, head movement is typically used to build complex words from syntactically separate material. Yet in this case, head movement would not create a word in any

obvious sense: the two elements *need* ‘these’ and *kõik* ‘every’ are written as separate words, speakers view them as separate words, and they do not seem to form a phonological word.³¹ Second, if I am correct that this movement is driven by information structural considerations, this runs counter to what we expect about head movement. Head movement is not typically motivated by pragmatic factors, but by morphosyntactic factors (Matushansky 2006). For these reasons, believe a phrasal movement analysis of demonstrative fronting is more promising.

If the analysis of demonstrative fronting is on the right track, then it seems that although demonstratives may fulfill some of the semantic functions of definite articles in other languages (say, English), it seems it would be premature to analyze Estonian demonstratives as exponents of D^0 . In other words, while the demonstratives may be developing into articles, the change is not yet complete.³²

2.2.4 Implications for the Small Nominal Hypothesis

In this section I proposed that Estonian, a language without articles, still has DP. Following the work of Bošković (2005), *et seq.* and Corver (1992), I showed that the predictions that a no- D^0 analysis makes about Estonian possessors are not borne out. First, Estonian nominals allow two non-lexical genitive arguments. This is a DP behavior according to Bošković’s (2008) diagnostics. Second, the conclusions about the syntax of possessors and demonstratives that proponents of the SNH are led to— namely, that they are adjectives (or “adjectival”)— do not extend naturally to Estonian possessors. Possessors in Estonian are morphosyntactically different from both (i) Estonian adjectives and (ii) Serbo-Croatian possessors. While there is interesting evidence in support of the idea that Serbo-Croatian possessors are not full DPs, the evidence for Estonian clearly points in the other direction. If it is precisely the no- D^0 analysis that is supposed to be at the core of the particular syntactic generalizations about Serbo-Croatian that the work on the SNH has uncovered, then it seems clear to me that Estonian should not be

³¹Both words receive normal stress in the demonstrative fronting construction, though there is usually a pitch accent on *kõik*. What’s more, it is in the default order *kõik need* where *need* is sometimes subject to phonological reduction— though to my ear, it sounds like it forms a unit with the following word in that case. The head movement analysis of demonstrative fronting predicts the opposite pattern, if anything. I am grateful to Reet Kasik (p.c.) for helpful discussion of this.

³²The head-movement analysis also predicts that *kõik* and *need* would behave as a unit, but I am not in a position to test this prediction, because I know of no syntactic processes that target the Q^0 head and only the Q^0 head.

given the same analysis. Consequently, I proposed a null- D^0 analysis of Estonian, where “bare” nouns are not syntactically bare— they still contain D^0 , but that D^0 may be covert.

I then considered whether there are any other D^0 heads in Estonian. Once we expand our view of D^0 heads beyond the class of articles, the answer appears to be yes. I investigated the indefinite pronoun construction in Estonian, ultimately arguing that their surface position is D^0 (Abney 1987, Larson & Marušič 2004). I also proposed that wh-determiners *mis* ‘what’ and *milline* ‘which’ are clear candidates for exponents of the D^0 position. In contrast, I argued that demonstratives are not D^0 heads, despite their potential to contribute determiner-like semantics. The evidence came from a process of fronting inside Estonian nominals targeting possessors and demonstratives. Because this fronting is obligatory for wh-possessors, I proposed that this was movement to the edge of DP (akin to wh-movement in the clause). The fronting of possessors and demonstratives can be treated the same if both elements are phrasal, but not if demonstratives are D^0 heads. My conclusions about demonstratives are thus in line with previous analyses of demonstratives (Alexiadou et al. 2007, Brugè 2002, Deal 2010, Giusti 1997, Harizanov 2011, Kramer 2009).

2.2.4.1 Some articleless languages have functional structure

Though we reach different conclusions, the proponents of the no- D^0 research program outlined by Bošković (2005, 2008) and the proponents of the null- D^0 analysis (including myself) are working towards a common goal. Both types of approaches seek a deeper understanding of the nature of the nominal extended projection. Speaking narrowly, the no- D^0 analysis and the null- D^0 analysis are both interested in properties of the D^0 head. Speaking more generally, both analyses are also interested in how much structure must or can be present in the nominal extended projection. There is still much disagreement surrounding both of these questions, so it is worth pausing for a moment to discuss what is at stake in the debate.

Focusing on the narrow question, the no- D^0 analysis assumes at least the following about the nature of D^0 . First, D^0 is the position of articles; based on the discussion in those works, perhaps D^0 is the position of articles only.³³ Second, the syntactic head D^0 has a number

³³It seems worth pointing out that it is not universally accepted that so-called indefinite or definite articles actually occupy D^0 . For example, Perlmutter (1970) proposes that the English indefinite article is actually lower than D^0 , and Lyons (1999) proposes that the definite article occupies Spec,DP, not D^0 . Perhaps this can be disentangled with a formal definition of an ‘article’— I will not speculate further on this issue here.

of universal properties. For example, Bošković (2008), Corver (1992) make explicit syntactic proposals that tie the possibility of Left Branch Extraction to the presence or absence of D^0 —in other words, D^0 makes Left Branch Extraction impossible. A property investigated more closely here is genitive case-marking. Though Bošković (2008) does not actually propose a formal account of the supposed generalization that articleless languages do not allow two genitive arguments, it seems that the most natural way to include it would be to propose that D^0 has the ability to license a(n additional) possessor.

In contrast, the null- D^0 analysis that I adopt first asserts that the D^0 position is the position of a number of different descriptive categories including, but not limited to, articles. Crosslinguistic variation emerges as a result of the properties of different D^0 heads, a situation consistent with the more general hypothesis that all language-specific variation can be localized to the (functional) lexicon, sometimes called the Chomsky-Borer Hypothesis (Borer 1984, Chomsky 1995). For example, some D^0 heads license another possessor, but other D^0 heads do not. In the strongest version of this view, it is not the presence or absence of such-and-such functional element that leads to different facts about a given language; instead, it is the properties of functional elements that lead to crosslinguistic variation. It seems to me that the same explanation could be applied to the kinds of generalizations that the NP/DP distinction is intended to explain, though I will leave this project for future research.

If the conclusions I have reached here are reasonable, the hypothesis Bošković (2008) calls the stronger hypothesis (the SNH, repeated below) needs to be revised.

- (39) **Small Nominal Hypothesis (SNH):** Nominals in all articleless languages are simply NPs (i.e., they do not project functional structure). (Bošković 2008)

If it is right to call Estonian an articleless language, and I believe it is, then Estonian is a clear counterexample to this claim. It does not exhibit any of the classic cases of NP behavior that previous work describes, and furthermore, it does seem to have some DP behavior. A version of the weaker hypothesis— that some languages without articles lack DP— may still obtain. I would like to spend a moment discussing what such a hypothesis might look like.

2.2.4.2 Towards a refinement of the SNH

The research that originally began the no- D^0 research program was based on a simple structure for nominals— one in which the only two heads in the nominal spine are D^0 and N^0 , as in (97)

(Abney 1987). However, most current research on nominal syntax assumes at least one more intermediate projection, often labeled Num(ber) (Ritter 1991) or ϕ^0 (Déchaine & Wiltschko 2002), as in (98).

(97) Abney-style nominals:

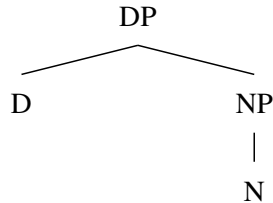

(98) Ritter-style nominals:

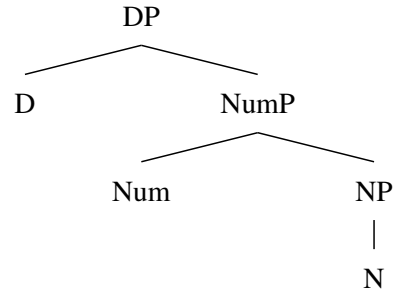

Considering the structure in (98), we could think about the no- D^0 analysis in two ways:

1. Nominals in articleless languages lack a particular functional head with particular syntactic properties. We usually call this head D^0 .
2. Nominals in articleless languages lack functional structure entirely (= the SNH).

One might interpret the claim that articleless languages lack D^0 to mean that articleless languages lack any functional projection that is labeled D^0 , but it seems clear to me that we do not want to base any syntactic analysis on the particular label that we give to a head. We could, for example, assert that a language like Estonian does not have a DP but does have a SpecificP (Cheng & Sybesma 2012, Sio 2006), but it is not clear how this is a claim about anything other than lexical semantics.³⁴ And indeed, the analyses proposed by Bošković (2005) and Despić (2013) do not hinge on the label of the functional element above NP, but on the presence of additional functional material.

The two hypotheses presented above make different claims about the presence of the intermediate NumP in (98). Option 1 above— that nominals in articleless languages lack DP, is compatible with the presence of NumP, but option 2— that nominals in articleless languages are just NPs— is not. At this point, it is worth pointing out that Bošković (2008, 2009) and Despić (2011) do not endorse the view that there is **never** functional material above NP in Serbo-Croatian. This is highlighted by the contrast between (99a) and (99b):

³⁴Thanks to Peter Jenks for very helpful discussion of this point and matters closely related to it.

- (99) a. * [NP Mnogi [N' Dejanovi_i [N' prijatelji]]] si posjetili njega_i.
 many.NOM Dejan's.NOM friends.NOM are visited him
 Intended: 'Many of Dejan_i's friends visited him_i.' (Bošković 2009:196)
- b. [QP Mnogo [NP Dejanovih_i [N' prijatelja]]] je došlo na njegovo_i venčanje.
 many Dejan's.GEN friends.GEN is came to his wedding
 'Many of Dejan_i's friends came to his_i wedding.' (Bošković 2009:198)

Co-reference is ruled out for *Dejanovi* 'Dejan's' and *njega* 'him' in (99a), but the same coreference is possible in (99b). Recall that the kind of impossible coreference seen in (99a) was argued to be the result of Condition B: *Dejanovi* is in the proper position to c-command *njega* (according to Despić (2011, 2013)), and this kind of pronoun cannot be bound by a clausemate. The addition of agreeing *mnogi* does not change this fact. This was taken as evidence that higher functional elements (quantifiers, as in (99a), or demonstratives (Despić 2013)) do not require additional functional structure in Serbo-Croatian, but are contained with NP. This extra material would presumably destroy the c-command relationship between *Dejanovi* and *njega* that is claimed to be the reason for the impossibility of coreference in (99a). Since (99a) is still ungrammatical with coreference, the claim is that there cannot be any additional functional structure.

Yet this coreference is possible in (99b). The descriptive difference is that (99b) contains a distinct version of *mnogo* (called "non-adjectival *many*" by Bošković (2009)). What is different about this version of *mnogo* is that it does not show concord with the nominal it modifies and instead, it assigns the so-called genitive of quantification to the material to its right. Bošković (2006) claims that non-adjectival *mnogo* and other forms like it are introduced in a separate projection above NP in Serbo-Croatian, represented in (99b) as QP. The claim, then, is that the additional structure due to non-adjectival *mnogo* destroys c-command between 'Dejan's' and 'him', making co-reference once again possible. If this is the explanation for the contrast in (99), then the correct formulation of the SNH cannot be that nominals in articleless languages lack functional structure entirely.³⁵

This leaves us with the final possibility: that articleless languages might have functional structure, but they have *less* functional structure than languages with articles. More specifically, they project functional structure, but they stop short of projecting the kinds of functional

³⁵Bošković (2008) also suggests the same possibility with respect to the SNH in his footnote 9: "I use the term DP/NP account for ease of exposition: most of the analyses below would not change if there is some functional structure in [nominals] of articleless languages (as long as it's not DP)."

elements that have the properties of D^0 .

(100) **Small Nominal Hypothesis, version 2:** Nominals in articleless languages do not contain as much functional material as nominals in languages with articles.

But it seems that Estonian is even a counterexample to this weaker hypothesis. Estonian looks like a language with a normal amount of nominal functional structure. It has multiple possessor positions. It has an edge position that is the target of A' movement. It has a wide variety of modifiers that are determiners in the classic sense— in other words, functional elements are not in short supply. Simply put, it is not clear to me that Estonian's lack of articles reveals anything about the language beyond the fact that bare nominals can freely appear in a variety of syntactic positions. I thus reject the SNH as written in (100).³⁶ It may be true that nominals in Serbo-Croatian have less structure than nominals in other languages. However, the evidence from Estonian suggests that we must reassess the way this kind of research is framed so that it no longer draws a meaningful line between languages with and without articles. The evidence from Estonian and other languages that has come to light during this debate shows that there is more variation than a division between having or not having articles suggests.

Another way forward is to assume that variation is not located in the presence or absence of functional material, but in the properties of that functional material (the Chomsky-Borer Hypothesis). In such a view, the differing properties of null-article languages with respect to, e.g., Bošković's diagnostics, would come down to the particular properties of the language's D^0 heads. And before we can seriously investigate the question of whether such-and-such functional element is present in a language's lexicon, we have to come to some consensus about the syntactic and semantic properties of that functional element. When it comes to the category D^0 , these debates are far from settled. At the very least, this investigation of Estonian nominals can be viewed as an argument for the simplest version of Abney's (1987) proposal: at least one functional head is universally available above NP. Insofar as the properties investigated here can be tied to DP, it seems clear that that functional head is D^0 .

³⁶Despić (2013) clarifies his proposal in the conclusion, saying "the assumption that [Serbo-Croatian] as an article-less language lacks DP... should not be mistaken for an attempt to claim that languages without articles completely lack any kind of functional projections in the nominal domain. ... UG offers a wider range of possibilities than suggested by the [Universal DP Hypothesis], where [Serbo-Croatian] and English stand on opposite sides of the spectrum." My conclusions specific to Estonian are thus fully compatible with Despić's conclusions.

I will now shift gears to discuss another empirically-rich domain in Estonian DPs: the relationship of cardinal numerals to the nominal extended projection.

2.3 Cardinal numerals in Estonian

In the next chapter, I will analyze some patterns of number concord in Estonian nominals. The most interesting patterns are only visible in DPs with cardinal numerals (simply “numerals” from this point forward). For this reason, I must clarify my assumptions about the syntax of numerals that the discussion in the next chapter can be based upon. There are two core questions that morphosyntactic investigations of numerals have considered. First, what is their category? Are they functional or lexical? If they are lexical, are they nouns, adjectives, or their own independent class? The second question concerns the numeral’s relationship to the nominal extended projection. This concerns both their syntactic position— specifier, adjunct, or head in the extended projection— as well as their height in the extended projection. In other words, what elements are merged before numerals, and what elements are merged after numerals?

I will begin by describing some of the aspects of the basic syntax and morphology of numerals in Estonian and the DPs they appear in. The most important facts to note will be the apparent presence of two number features and two case features within the same DP. I will then discuss some of the previous syntactic analyses, ultimately adopting the view for numerals espoused by Ionin & Matushansky (2006), Danon (2012) that numerals may be heads in the nominal extended projection in the following section.

2.3.1 The numeral’s “complement”

First, I must define some terminology. I will refer to DPs containing cardinal numerals and nouns as NUMERAL-NOUN CONSTRUCTIONS or NNCs. I will refer to the material structurally lower than the numeral (in terms of linear order, the material to its right) as the NP⁺, because it is a nominal constituent smaller than DP, but as I will argue, it is not just an NP. I use the term NUMERAL to apply to cardinal numerals only— I will not discuss ordinal numerals here, as their morphosyntactic behavior in Estonian suggests they are no different from adjectives (Erelt et al. 1993b, 2000).

There are two sets of facts to be discussed with respect to NNCs: syntactic facts and

morphological facts. I will begin with morphology. Nouns in combination with numerals in Estonian are singular (see Ortmann 2000 for discussion of this phenomenon in other languages). What's more, in nominative and accusative contexts, the NP⁺ must bear partitive case. Plural nouns (101) and nominative nouns (102) are ungrammatical.³⁷

- (101) a. kaks / sada inimes-t
two / hundred person-(SG)PAR
'two / a hundred people'
- b. * kaks / sada inimes-i
two / hundred people-PL.PAR
- (102) a. * kaks / sada inimene
two / hundred person.NOM
Intended: 'two / a hundred people'
- b. * kaks / sada inimese-d
two / hundred people-PL.NOM

It is possible to have adjectives in the NP⁺, and those adjectives must also be singular and partitive.

- (103) a. kaks rikas-t inimes-t
two rich-(SG)PAR person-(SG)PAR
'two rich people'
- b. * kaks rikas inimes-t
two rich-(SG)NOM person-(SG)PAR
- c. * kaks rikka-d inimes-t
two rich-PL.NOM person-PAR
- d. * kaks rikka-id inimes-t
two rich-PL.PAR person-PAR

There do not seem to be any restrictions on the kinds of adjective (phrase)s that can appear in this position. For example, they can have degree words like *väga* 'very' or *üsna* 'rather' (104). They can also have complements, as with the deverbal adjectives in (105).³⁸

- (104) a. kaks väga rikas-t inimes-t
two very rich-(SG)PAR person-(SG)PAR

³⁷If the numeral itself is also plural, then partitive case is no longer assigned (i.e., in a nominative environment, the head noun surfaces in nominative case, not partitive case). I return to this issue in section 2.4.4.

³⁸I will return to an analysis of deverbal adjectives in the next chapter; to be clear, I will just note at the moment that the partitive-marking on *pankrotti* 'bankruptcy' and *vene keelt* 'Russian' has nothing to do with the numeral.

- ‘two very rich people’
- b. kaks üsna arusaa-da-va-t eesmärki
two rather understand-PASS-PRS.PCPL-PAR goal.PAR
‘two rather understandable goals’ (BALANCED)
- (105) a. kaks [pankrotti puuduta-va-t] seadus-t
two bankruptcy.PAR deal.with-PRS.PCPL-PAR law-PAR
‘two laws dealing with bankruptcy’ (BALANCED)
- b. üle miljoni [vene keel-t kõnele-va-t] isiku-t
over million.GEN Russian language-PAR talk-PRS.PCPL-PAR individual-PAR
‘over a million Russian-speaking individuals’ (BALANCED)

I assume that the adjectives merged below numerals are normal APs.

Interestingly, any material merged higher than the numeral, like demonstratives, must be plural:

- (106) a. nee-d viis inimes-t
DEM-PL.NOM 5 person-PAR
‘those 5 people’
- b. * see viis inimes-t
DEM.SG.NOM 5 person-PAR
- (107) a. noo-d neli kõrg-poliitilis-t isanda-t
those-PL.NOM four.NOM high-political-PAR lord-PAR
‘those four lords from upper-class politics’ (BALANCED)
- b. * too neli kõrg-poliitilis-t isanda-t
that-NOM four.NOM high-political-PAR lord-PAR

I will propose an analysis of number concord in the next chapter, but for now, it is enough to note the following morphological facts about Estonian NNCs:

1. Material in the NP⁺ is singular and partitive.³⁹
2. Material above the numeral is plural and bears the case-marking of the DP— in other words, it is not required to be in partitive case.

What I will discuss more deeply in this chapter is the syntax of NNCs. There are two questions to be answered. First, what is the syntactic relationship of the numeral to the greater

³⁹Again, this is only if the entire DP is nominative or accusative— I will discuss what happens for other cases momentarily.

DP? In other words, what syntactic position do they occupy? Second, how big is the NP⁺? These questions are clearly intertwined, and authors rarely answer one without addressing the other. Before discussing these analyses, I must provide some more data. As we have already seen, the NP⁺ can contain adjectives (103), but (108) shows that NP⁺ can also contain possessors.

- (108) a. kaks minu hea-d tuttava-t
 two 1SG.GEN good-PAR acquaintance-PAR
 ‘two good acquaintances of mine’ (PARLIAMENT)
- b. [Kaks Kärdi sviitri-t] on Heiko koo-t-ud.
 two Kärt.GEN sweater-PAR be.3 Heiko.GEN knit-PASS-PST.PCPL
 ‘Two of Kärt’s sweaters were knit by Heiko.’

However, NP⁺ is not just another DP— some elements are prohibited from appearing in the NP⁺. Perhaps unsurprisingly, the NP⁺ cannot contain any other quantificational elements. For example, neither the strong quantifier *kõik* nor other numerals can appear in the NP⁺, as we see in (109). It is also not possible to have demonstratives in the NP⁺. This is shown in (110) for *see*, the only demonstrative in Standard Estonian, and for the colloquial *too*, most common in southern Estonia.

- (109) No quantificational elements in NP⁺: (110) No demonstratives in NP⁺:
- a. * kolm kõike õpilas-t a. * kolm seda õpilas-t
 3 every.PAR student-PAR 3 DEM.PAR student-PAR
- b. * sada nelja õpilas-t b. * sada toda õpilas-t
 100 4.PAR student-PAR 100 that.PAR student-PAR

It is perhaps worth noting that having demonstratives after numerals would create the order Num-Dem-A-N, which is as yet unattested neutral order of elements in the world’s languages (Abels & Neeleman 2012, Cinque 2005, Dryer 1992, Greenberg 1963). In light of that, perhaps the fact that demonstratives cannot appear in the NP⁺ is also unsurprising. If demonstratives are used with NNCs, they must appear to the left of the numeral, as we saw in (106).

I take the demonstrative facts as evidence that the NP⁺ is not a full nominal extended projection (Abels & Neeleman 2012, Cinque 2005)— in other words, it is not a DP. This seems to be the general consensus in the literature. Yet while there is agreement that the NP⁺ is small, there is less agreement about *how* small. Descriptively, we know that the NP⁺ in Estonian must be large enough to contain possessors and adjectives (in addition to the noun). Let us turn to

some discussion of previous analyses of NCCs before considering how we might analyze the Estonian data.

2.3.2 Previous analyses of numeral-noun constructions

To my knowledge, there are three kinds of analyses of the syntax of numeral-noun constructions. Under one analysis, numerals are (phrasal) specifiers of a functional projection above NP. This view is often attributed to Zabbal (2005), though the same analysis has been either proposed or assumed by others (see, e.g., Deal 2013a, Julien 2005, Watanabe 2006). For concreteness, I assume this functional projection is Num⁰, as represented in (111).

(111) Numerals as phrasal specifiers:

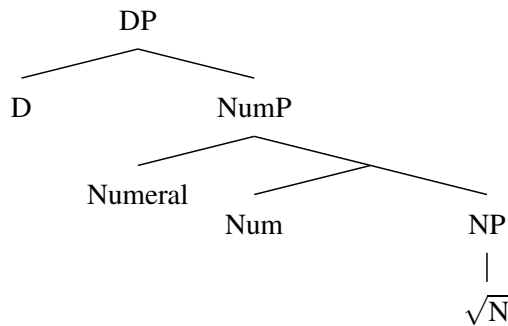

Under another kind of analysis, proposed by Ionin & Matushansky (2004, 2006), Nelson & Toivonen (2000), Ritter (1991), numerals are heads in the nominal extended projection. Ionin & Matushansky’s specific proposal is that numerals are N⁰ heads taking NP complements, as in (112):

(112) Numerals as heads in the nominal extended projection:

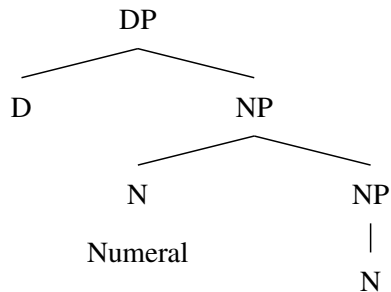

These analyses are built to explain different sets of facts— that is to say, they more easily account for different sets of data

2.3.2.1 Ionin & Matushansky 2006: In support of the numerals-as-head analysis

Perhaps the most compelling evidence for the head-complement structure comes from case assignment. As we saw in Estonian, the addition of a numeral can result in different case-marking on the head noun (or more properly, on the NP⁺). This fact alone is not an argument for either structure; case assignment can easily be incorporated into either analysis for numerals. In the head-complement view, it is the numeral itself that assigns case to its complement. In the specifier-head view, it is the functional head hosting the numeral that is responsible for case assignment.

(113) a. Numerals as heads:

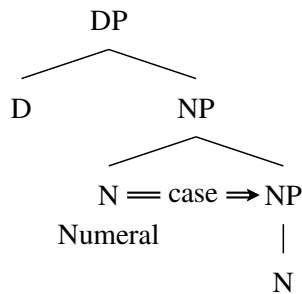

b. Numerals as specifiers:

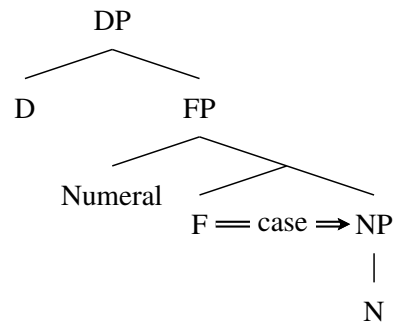

Thus, I do not believe the mere presence of apparent case-assignment by numerals supports one analysis over another. However, if we dig a bit deeper, there are facts which are more readily incorporated into the head view than the specifier view.

In some languages, the identity of the noun's case value in a NNC depends on the numeral. This is exemplified for Russian (Ionin & Matushansky 2004, 2006) and Inari Sami (Nelson & Toivonen 2000) below:⁴⁰

(114) Russian (Ionin & Matushansky 2006:19):

- a. četyre šagá
 four step.PAUC/GEN.SG
 'four steps'

⁴⁰The marking assigned by the numerals 2–4 in Russian is sometimes referred to as “genitive singular,” and for the vast majority of nouns in the language, this characterization is not problematic. However, there are a handful of nouns (‘step’ is one of them), where the form that appears after 2–4 is distinct from the genitive singular form for that nominal. For this reason, Ionin & Matushansky (2006) call this form ‘paucal’, though they are not the first to do so. This complication is sometimes glossed over in other analyses, which is why I have glossed *šagá* as PAUC/GEN.SG.

- b. šest' šagov
 six step.GEN.PL
 'six steps'

(115) Inari Sami (Ionin & Matushansky 2006:20):

- a. kyehti/ kulmâ/ nelji/ vittâ/ kuttâ päärni
 2/ 3/ 4/ 5/ 6 child-ACC.SG
 '2 / 3 / 4 / 5 / 6 children'
- b. čiččâm/ kávcí/ ovce/ love/ ohtnubáloh/ kyehtnubáloh/ čyeti pärnid
 7/ 8/ 9/ 10/ 11/ 12/ 100 child-PAR.SG
 '7 / 8 / 9 / 10 / 11 / 12 / 100 children'

In Russian, numerals 2-4 assign what looks like genitive singular for most nouns (see footnote 40), and higher numerals assign what looks like genitive plural. In Inari Saami, numerals 2-6 assign accusative case, and higher numerals assign partitive case.

In the head analysis, the choice of case assigned can easily be tied to the properties of the head that assigns them, because it is actually the head itself that assigns case. Thus, similarly to verbs that idiosyncratically assign dative case to their complements, we could say that numerals 2-6 in Inari Sami assign accusative case, whereas numerals elsewhere assign partitive case. In the numerals-as-specifier analysis, it is not the numeral itself that assigns case, but the functional head hosting the numeral in its specifier. Thus, in order to capture the facts in (114) and (115), the properties of the functional head would have to be sensitive to the particular lexical item that makes up its specifier, which is not the kind of relationship we typically expect to see between a head and its specifier.

A similar argument comes from multiplicative numerals like *four hundred*. In multiplicative numerals, the case assigned to multiplicands like *hundred* or *thousand* is the same as that which is normally assigned by the multiplier:

(116) Case assignment in multiplicative numerals (Russian, Ionin & Matushansky 2006:20)

- a. četyre tysjači šagov
 four thousand-PAUC step.GEN.PL
 'four thousand steps'
- b. pjat' tysjači šagov
 five thousand-GEN.PL step.GEN.PL
 'five thousand steps'

So, in (116a), we see that *četyre* ‘four’ assigns the same paucal/genitive singular to ‘thousand’ that it assigned to ‘step’ in (114a). Similarly, *pjat* ‘five’ assigns genitive plural to ‘thousand’ in (116b), just like *šest* ‘six’ assigned to ‘step’ in (114b).

In the numerals-as-head analysis, multiplicative numerals are usually analyzed as recursive structures (see (117)).

(117) Multiplicative numerals as recursive structures (Ionin & Matushansky 2006)

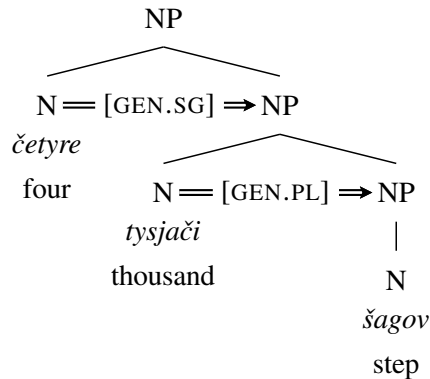

In this analysis, the fact that ‘four’ assigns the same case to ‘hundred’ as it does to ‘step’ in a normal NNC is exactly as we expect, because ‘four’ has the same relationship to ‘hundred’ as it would have to ‘step’. Under the specifier analysis, the connection is not as natural. In ‘four steps’, the case-marking on step comes not from ‘four’, but from the functional head, as in (118).

(118) Numerals as specifiers (Zabbal 2005)

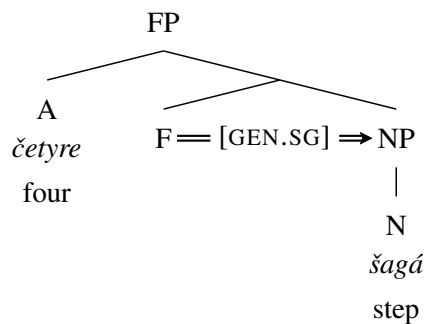

Multiplicative numerals like ‘four hundred’ are typically phrasal specifiers in the numerals-as-specifiers analysis. This means that ‘four’ and ‘hundred’ do not stand in the same syntactic relationship as ‘four’ and a normal noun. The normal noun is the complement of a functional

head hosting the entire numeral in its specifier. The relationship between ‘four’ and ‘hundred’ is less clear— Zabbal (2005) proposes that they are in a head-adjunction structure, as in (119).

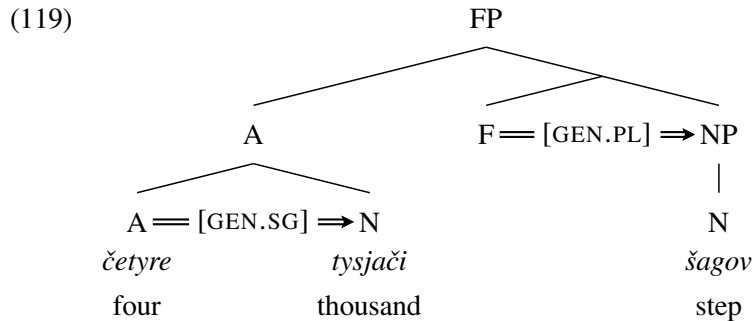

Given that these relationships are different, the fact that ‘hundred’ and ‘step’ bear the same case when used with ‘four’ (see (116) and (114)) is accidental and requires an additional stipulation.

2.3.2.2 Danon 2012: Against head-complement as the only structure

To my mind, the evidence from case-marking is the most compelling morphosyntactic argument in favor of the numerals-as-heads analysis. However, Danon (2012) argues that this cannot be the only structure crosslinguistically. Ultimately, the main thrust of Danon’s (2012) article is not to argue against either approach, but rather, to argue in favor of both of them.

One of the more compelling arguments that Danon makes has to do with word order. In a world where NNCs in all the world’s languages have the numerals-as-head structure, we would expect that there would be a correlation between (i) a language’s general headedness, and (ii) the order of nouns and numerals in that language. Concretely, in a head-final language, we would expect numerals to follow nouns. This would be in line with the general tendency for OV languages to have auxiliaries after main verbs and to have postpositions instead of prepositions. Quite interestingly, this is not what we find. In fact, the two orders of numeral noun are “equally common among OV languages” (Dryer 1992). This is illustrated for Turkish below, though Danon (p. 1288) also cites Amharic, Basque, Hindi, and Persian as head-final languages with the order Numeral-Noun:

(120) Turkish:

- | | | | |
|----|-------------------------------------|----|------------------------|
| a. | on kitap
ten book
‘ten books’ | b. | * kitap on
book ten |
|----|-------------------------------------|----|------------------------|

Numerals in Turkish come before the noun they modify. If numerals in Turkish are heads, this would be puzzling, as Turkish is otherwise a rigidly head-final language.

Danon also cites work by Corver & Zwarts (2006) on things like *around ten* and *between two and seven*, collectively called “prepositional numerals.” Corver and Zwarts present many arguments in favor of treating prepositional numerals as constituents to the exclusion of the head noun (e.g., *[[around ten] books]* as opposed to *[around [ten books]]*). The arguments are all tied to the ways in which a phrase like *around ten books* behaves like a DP and not like a PP. For example, verbs that select DP complements can select DPs with prepositional numerals:

(121) Dutch (Corver & Zwarts 2006:821):

- a. Jan ontmoette [de kinderen]
J met the children
(normal DP object)
- b. * Jan ontmoette [rond de kinderen]
J met around the children
(PP object)
- c. Jan ontmoette [rond de twintig kinderen]
J met around the twenty children
'Jan met approximately twenty children' (Prepositional numeral)

The Dutch verb *ontmoeten* ‘meet’ can take DP objects but not PP objects headed by *rond* ‘around’ (see the contrast between (121a) and (121b)). However, the version in (121c), with a DP that looks superficially similar to the one in (121b), is ok. Corver and Zwart’s explanation is that the nominal in (121c) is a DP, not a PP.

This conclusion is easier to integrate with the numerals-as-specifiers analysis. Given that the numeral is already a constituent to the exclusion of the noun, we can capture the constituency and category facts by simply treating the preposition as part of the numeral phrase. This is essentially what Corver and Zwarts do:

(122) Prepositional numerals as phrasal specifiers:

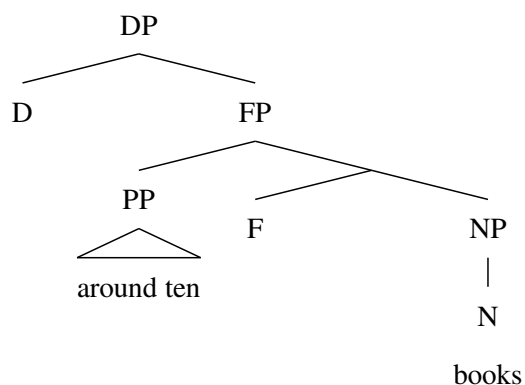

Note that the category of the entire nominal is DP under this analysis, in line with Corver & Zwarts’s (2006) conclusions. I will not discuss their arguments for the PP category label in (122); that point is tangential to the point being made here. If Corver and Zwarts are on the right track, then prepositional numerals are evidence in favor of the numerals-as-specifiers analysis.⁴¹

There are compelling arguments in favor of the numerals-as-heads analysis, and there are compelling arguments in favor of the numerals-as-specifiers analysis. In most of the literature on NNCs, authors argue for one view or the other as the only possible structure crosslinguistically. *Contra* much previous work, (Danon 2012) contends that both structures in (111) are possible crosslinguistically and within the same language. This proposal has also been made for numerals in Russian by Franks (1994) and Pereltsvaig (2006). According to this analysis, there is no single structure for NNCs crosslinguistically— but rather, both may be available, even in the same language (see Hankamer (1977) on multiple analyses). This is particularly

⁴¹Danon also discusses examples that seem problematic for the numerals-as-heads analysis if one adopts the view that numeral heads have to assign case to their complements:

- (i) a. Ég þekki þrjá íslenska málfræðinga.
 I know three.ACC Icelandic.ACC linguists.ACC
 ‘I know three Icelandic linguists.’ (Icelandic, Thráinsson 2007:103)
- b. Menq tv-el enq ayd harc-ə tasə masnaget-i.
 we.NOM give-PF.PART AUX ayd question-DEF.ACC ten specialist-DAT
 ‘We gave the question to ten specialists.’ (Eastern Armenian, Danon 2012:1287)

In these examples, either the noun and numeral agree in case (as in Icelandic) or the noun simply bears normal case-marking (as in Eastern Armenian). However, if we abandon the assumption that case-marking is obligatory in the numerals-as-heads analysis, then these data are easily incorporated. We must simply say that numerals in Icelandic and Eastern Armenian do not assign case.

clear for languages that have two different forms of (cardinal) numerals with differing syntactic behavior, as in Modern Hebrew.

2.3.2.3 Danon 2012: two structures for NNCs in Hebrew

First, observe that many Modern Hebrew numerals have two forms, which Danon calls BOUND and FREE forms. The bound form resembles a Semitic construction known as the Construct State.⁴²

- (123) a. šlošà (sfarim)
 three.FREE books
 ‘three (books)’ (Danon 2012:1283)
- b. šlōšet *(ha-sfarim)
 three.BOUND the-books
 ‘the three books’ (Danon 2012:1283)

The free form, in contrast, can appear in isolation and does not require any definiteness marking on the noun.

Danon provides three arguments that bound numerals have a different distribution than free numerals. First, bound numerals must be linearly adjacent to the noun they modify (124). Second, they cannot be part of complex “numeral phrases” as in (125). Finally, bound numerals do not allow extraction of the noun (126). In all of these cases, only free numerals may be used.⁴³

(124) Bound numerals must be adjacent to the noun (Danon 2012:1286):

- a. šloša ve mašehu sfarim
 three.FREE and something books
 ‘A little over three books’
- b. * šney ve mašehu sfarim
 two.BOUND and something books

(125) Bound numerals cannot be in complex numeral phrases (Danon 2012:1286):

⁴²A construct state is a genitival structure present in many Semitic languages. See Ritter (1991) among others for an investigation of its properties.

⁴³Danon connects all of these facts to the Construct State, a construction used to indicate possession in many Semitic languages. The restrictions just noted for bound numerals also hold of nominals in the Construct State, and the analysis that Danon ultimately proposes for bound numerals is directly inspired by analyses of the Construct State (see, for example, Ritter 1991).

- a. ben exad le šloša sfarim
 between one.FREE to three.FREE books
 ‘between one and three books’
- b. * ben exad le šney sfarim
 between one.FREE to two.BOUND books

(126) Bound numerals do not allow “extraction” of the noun (Danon 2012:1286):⁴⁴

- a. ze haya dubim še-ra’iti šloša.
 it was bears that-saw.1SG three.FREE
 ‘It was bears that I saw three of.’⁴⁵
- b. * ze haya dubim še-ra’iti šney.
 it was bears that-saw.1SG two.BOUND

Note that the choice between bound and free numerals is not just about linear adjacency. In (125), the bound *šney* ‘two’ cannot be used, even though it is adjacent to the head noun.

On the basis of data like these, Danon argues that bound numerals and free numerals should be given different syntactic structures. Concretely, he proposes that bound form numerals are also heads embedding a nominal extended projection. In contrast, free form numerals are full phrases occupying the specifier position of some functional head.

(127) Bound numerals as heads:

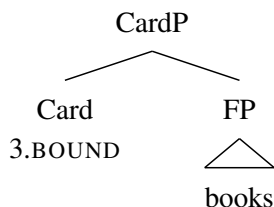

(128) Free numerals as specifiers:

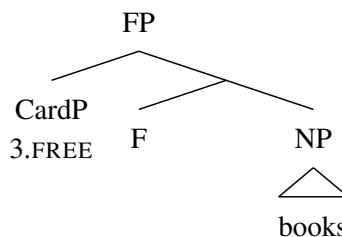

Recall from above that the bound form requires the noun to be definite. When normal numerals are used with indefinite nouns, they must be in the free form. Interestingly, if the numeral itself bears plural-marking, this restriction no longer holds. When pluralized numerals are followed by a noun, they can only appear in the bound, even if that noun is indefinite.

(129) Hebrew:

⁴⁴Danon himself does not provide an analysis of the structures in (126), so the term extraction he uses does not necessarily mean that the structures in (126) involve movement.

⁴⁵Danon’s translation of (126a) is *It was bears that I saw three*, which I find to be ungrammatical. The translation provided is a grammatical version of what I assume this sentence is supposed to mean.

- a. esrot / *asarot sfarim
tens.BOUND / tens.FREE books
'tens of books' (Danon 2012:1294)
- b. asara / *aseret (sfarim)
ten.FREE / ten.BOUND books
'ten (books)' (Danon 2012:1294)

Following his conclusion that bound-form numerals have a head-complement structure, Danon argues that plural morphology on the noun constrains the choice of NNC, such that only the head-complement structure is possible. Danon suggests that this pattern is not localized to Hebrew. He observes that, in various languages, when the numeral is morphologically marked for number (i.e., when it is overtly plural), there is reason to believe a slightly different structure is being used. For example, in English, pluralized numerals require *of*, whereas they otherwise forbid it.

- (130) a. hundreds *(of) books b. a hundred (*of) books

To account for his suggestion that pluralized numerals require the numerals-as-heads structure, Danon proposes that there are two heads hosting number features in that structure (see also Borer (2005), though Borer identifies the lower head as a Classifier projection). Thus, the only way to get a numeral with plural marking (in Hebrew) is to use the head-complement structure, which is the structure for bound numerals. In contrast, there is only one Num⁰ head in the specifier-head structure, which is used for free numerals. Danon does not actually provide examples of the structures for both kinds of Hebrew NNCs (the specifier-head construction is absent), so I represent the trees he provides for English instead:⁴⁶

- (131) hundreds of books⁴⁷

⁴⁶The tree that Danon provides for the noun-complement construction involves Card⁰ embedding a DP complement ((46), p. 1299). It seems that what he wishes to commit himself to is that the noun-complement construction is recursive, but he seems to remain uncommitted to the exact label (or size) of the embedded nominal projection, as long as it is larger than simply NP.

⁴⁷Danon adopts the oft-made assumption that 'of' in this example is not a true preposition, but a kind of case-marker.

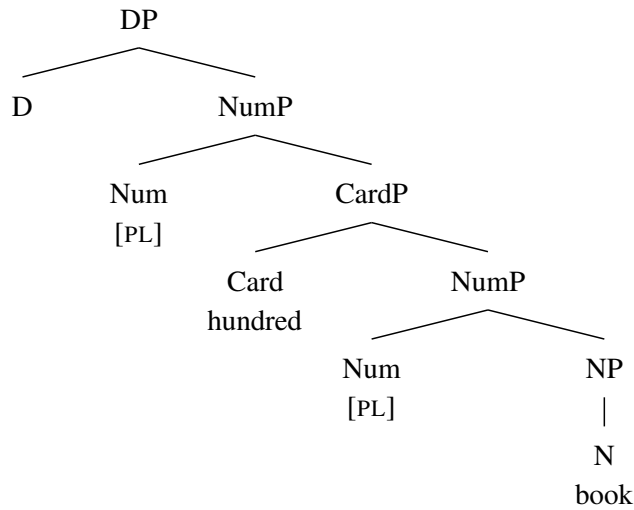

(132) ten books

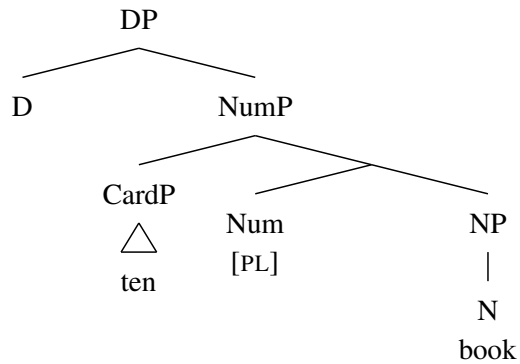

Descriptively, Danon ultimately proposes that the choice between NNC structures is constrained in two ways:⁴⁸

(133) **The number constraint:** The [specifier-head structure] is not possible if both the numeral and the noun carry independent morphosyntactic number features.

(Danon 2012, p. 1304)

(134) **The case constraint:**

- a. DP-internal case assignment to a projection of the noun that excludes the numeral is possible only in the [head-complement structure].
- b. The [head-complement structure] *must* involve DP-internal assignment of abstract case to a projection of the noun that excludes the numeral.

⁴⁸Danon considers some possible explanations for these constraints in the paper, but the specifics of those explanations remain to be fleshed out, so I will not discuss them here.

(Danon 2012, p. 1297)

If Danon’s approach is on the right track, then encountering certain facts about a language’s NNCs will lead to clear hypotheses. If a language has case-marking conditioned by numerals and/or if its NNCs exhibit two independent morphosyntactic number features, then it must have head-complement NNCs. Any NNC lacking those empirical properties could be analyzed with the specifier-head construction.

As we have seen, Estonian NNCs exhibit both (i) case-marking and (ii) independent morphosyntactic number features. In what follows, I will propose that the basic NNC in Estonian has a head-complement structure. What will be crucial for my account is that the head-complement construction involves case-marking and an additional number feature. I will also discuss another NNC found in Estonian, proposing that this NNC instantiates the specifier-head NNC in the language. I will suggest the choice between the two is regulated by syntactic selection.

2.4 Two structures for NNCs in Estonian

I propose that NNCs in Estonian generally have the head-complement structure, so that a DP like *kaks meest* ‘two.NOM man.SG.PAR’ minimally has the structure below:

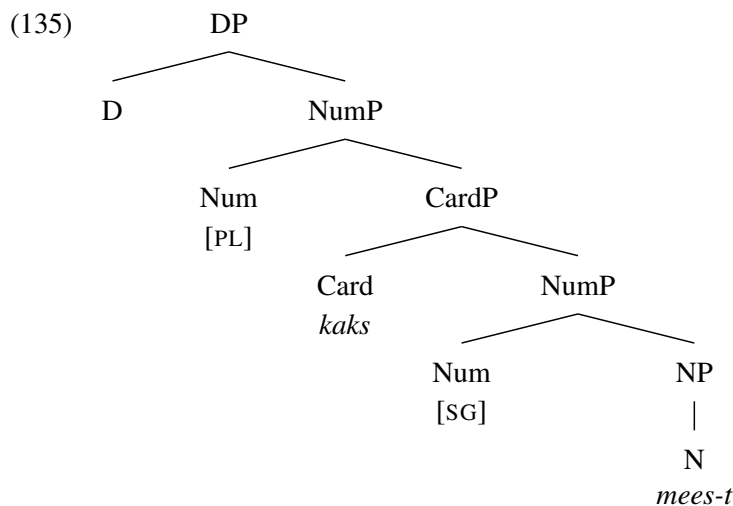

Building on Danon’s (2012) discussion, the structure in (135) immediately accounts for the core syntactic properties of NNCs in Estonian. First, the presence of a numeral conditions partitive case-marking— one of the core pieces of evidence used for a head-complement structure. For

the moment, I assume this case is assigned directly by the Card⁰ head to its complement. I will return to partitive case assignment in the discussion of Estonian pseudopartitives in chapter 4. Second, the NP⁺ is big enough to contain possessors and adjectives, but it is too small to contain demonstratives, which must be merged higher than NumP. Finally, this structure postulates two number features: one above numerals and one below numerals. This will give us a way to account for the presence of plural-marking on elements merged higher than the numeral.⁴⁹ The novel extension of Danon’s theory that I make is that the higher number feature can be present even in cases where it is not morphologically marked on the numeral itself. The connection between the functional head introducing a feature value and the loci of that feature’s expression is non-trivial in a language with robust nominal concord, like Estonian. I will begin with discussion of the size of the NP⁺.

2.4.1 The size of the NP⁺

One of the facts that my proposal in (135) aims to capture is the size of the NP⁺. Recall section 2.3.1 that possessors and adjectives are possible inside the NP⁺ of an NNC (108), but demonstratives are not (110).

(108) Possessors and adjectives in NP⁺:

- a. kaks minu hea-d tuttava-t
two 1SG.GEN good-PAR acquaintance-PAR
‘two good acquaintances of mine’ (PARLIAMENT)
- b. [Kaks Kärdi sviitri-t] on Heiko koo-t-ud.
two Kärt.GEN sweater-PAR be.3 Heiko.GEN knit-PASS-PST.PCPL
‘Two of Kärt’s sweaters were knit by Heiko.’

(110) No demonstratives in NP⁺:

- a. * kolm seda õpilas-t
3 DEM.PAR student-PAR
- b. * sada toda õpilas-t
100 that.PAR student-PAR

⁴⁹Furthermore, the cardinal numeral conditions the presence of the higher Num⁰ head— I assume it is only present when there is a cardinal numeral. I follow Danon in suggesting that this relationship can be handled by selection— Num⁰ heads can select either CardP or NP complements.

These facts follow straightforwardly from the structure in (135) if adjectives are adjoined to NP and (low) possessors are merged as specifiers of NumP (Kramer 2009):

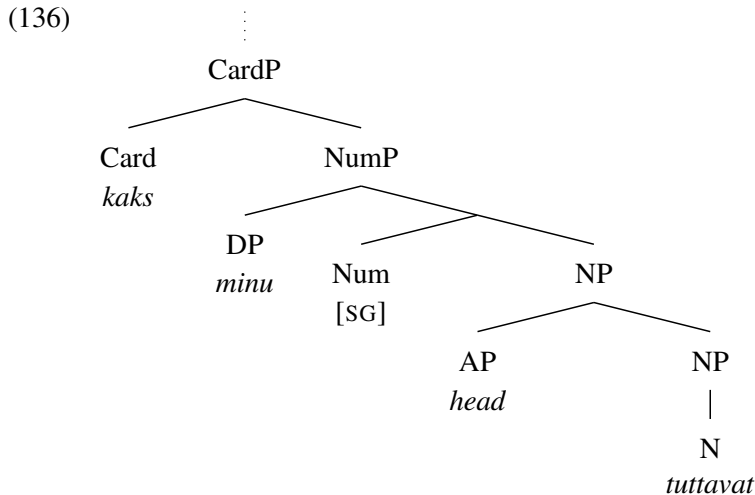

Recall that complex possessors and complex APs are possible in this low position. In other words, they are normal APs and possessors.

The structure above predicts that demonstratives should be impossible in the NP⁺, and as we have seen, that is indeed the case. The conclusion I made in section 2.2.3.1 was that demonstratives are merged as specifiers of a functional projection— one that must be below the location of the quantifiers *kõik* and *iga*. The exact nature of the functional category is immaterial for our purposes. All that matters is that demonstratives are merged too high to be in the complement of a numeral. This is captured straightforwardly given the proposal that the NP⁺ is actually NumP.

Before continuing, it is worth taking a moment to consider the similarities between Estonian NNCs and the Estonian pseudopartitive. The most notable similarity is that, as in NNCs, the ‘measured’ noun in a pseudopartitive also bears partitive case.

- (137) a. hargi-täis põhku
pitchfork-ful.NOM straw.PAR
‘a pitchforkful of straw’ (EKSS, entry for *hargitäis*)
- b. Taeva-s tiirle-s parv pääsukes-i.
sky-INE wheel-PST.3SG flock.NOM swallow-PL.PAR
‘A flock of swallows wheeled in the sky.’ (Nemvalts 1996:69)

In a pseudopartitive construction in Estonian, there is a nominal head serving some quantificational purpose (*hargitäis* and *parv* in (137)) and another nominal that is being measured

(*põkhu* and *pääsukesi* in (137)). Note that, just as in Estonian NNCs, the second element bears partitive case. Thus, one might hypothesize that Estonian NNCs are actually partitive constructions, assimilating them to the constructions in (137) (or vice versa). The pseudopartitive construction will be the focus of chapter 4, but I would like to take a moment to show some ways in which the Estonian pseudopartitive construction differs from NNCs.

2.4.1.1 Aside: NNCs are different from (pseudo)partitives

First, although they have identical case-marking, the number-marking facts are different. In Estonian NNCs, the noun must be singular. Though I did not discuss it explicitly, the noun in an NNC must be a count noun as well. In Estonian pseudopartitives, both mass nouns (137a) and count nouns (137b) are possible. Furthermore, when count nouns are used in pseudopartitives, they must be generally be *plural*:

- (138) * parv pääsukes-t
 flock swallow-PAR
 Intended: ‘a flock of swallows’

I note this here mainly for descriptive reasons—the number-marking facts suggest (but do not require) a different analysis for pseudopartitives and NNCs.

More troublesome for the prospects of a unified analysis is the fact that the “NP⁺” in pseudopartitives appears to be larger than the NP⁺ in NNCs. The evidence comes from two related facts. First, demonstratives are possible in pseudopartitives, but they are not possible in NNCs (see (110), repeated below).

- (139) Demonstratives in pseudopartitives:
- a. enamik ne-id rakendusakte
 majority DEM-PL.PAR implementation.provisions.PL.PAR
 ‘a majority of those implementation provisions’ (PARLIAMENT)
 - b. kott ne-id väikse-id kartule-id
 bag.NOM DEM-PL.PAR little-PL.PAR potatoes.PL.PAR
 ‘a bag of those little potatoes’

- (110) No demonstratives in NP⁺:
- a. * kolm seda õpilas-t
 3 DEM.PAR student-PAR

- a. kahe-d püksid
two-PL.NOM pant-PL.NOM
'two pairs of pants'
- b. nelja-d kingad
4-PL.NOM shoe-PL.NOM
'four pairs of shoes'

This form is clearly morphologically distinct from the form used in typical NNCs. I will return to these plural numerals momentarily. For now, given that I have proposed that Estonian NNCs essentially have a parallel structure to English *hundreds of books*, we should ask why the marking is different.

Danon is silent on the issue of how the number feature ends up being marked on the numeral, but that may be because there is not much to say— the heads are syntactically and (presumably) linearly adjacent. They could come together via one of the many ways that have been argued to exist for syntactically distinct terminal nodes to become single words (to name a few: head movement, Lowering, Local Dislocation (Embick & Noyer 2001), or Spanning (Merchant To appear, Svenonius 2012)). Now, the application (i.e., presence) of these processes in the grammars of languages is known to be idiosyncratic— though head movement is arguably present in many languages, there is variation with respect to how ‘high’ the verb moves. This is the explanation that I give for this difference between Estonian and English: whatever mechanism is behind the merger of Num_[PL]⁰ and Card⁰ in English is absent in Estonian. In Estonian, these two heads never get any closer than they are in the syntax.⁵⁰

2.4.3 Higher adjectives and possessors

We are not quite done. We have seen so far that possessors and adjectives are possible inside of the NP⁺, but they are also possible above the numeral, as in the examples below:

- (145) a. riigi viimase-d kaks suur-t tööseisaku-t
country.GEN last-PL.NOM 2 big-PAR work.stoppage-PAR
'the country's last two big work stoppages' (BALANCED)
- b. selle aasta esimese-d kuus kuu-d
this.GEN year.GEN first-PL.NOM 6 month-PAR
'the first six months of this year' (PARLIAMENT)

⁵⁰One should wonder what happens to the Num_[PL]⁰ at Vocabulary Insertion (i.e., how is it spelled out?). The answer may lie in the difference between languages with nominal concord and those without. I do not have a definitive answer, but one might propose that in Estonian, Num⁰ heads have no phonological realization themselves, and that any instance of the realization of plural features is actually some other head. The analysis of concord that I will propose in the next chapter essentially follows this line of attack.

To account for this, I propose the presence of another projection in between DP and the higher NumP, which I will label as FP. This is the location of possessors. As for higher adjectives, the fact that they surface as plural suggests they are adjoined no lower than the higher NumP. This is what I will assume.

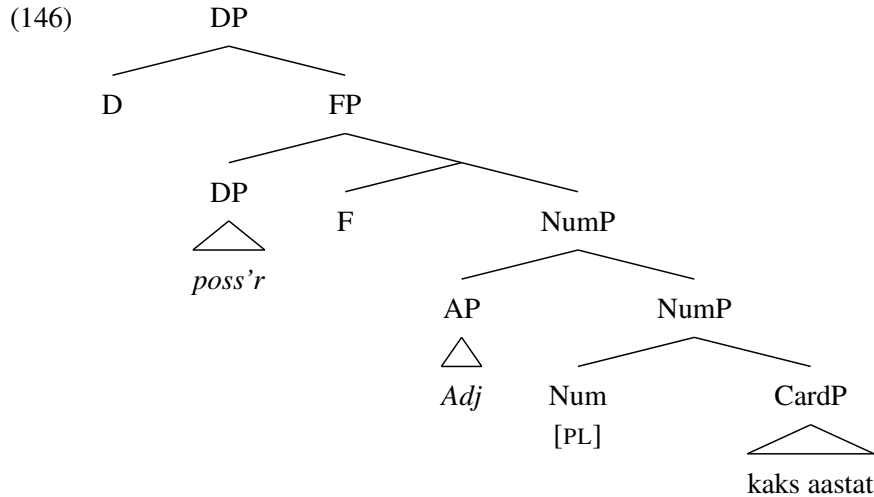

Thus, on the surface, there are (at least) two positions for adjectives and two positions for possessors. One should wonder immediately whether the different positions are independent of each other. In other words, can adjectives and possessors be initially merged in these high positions, or are they moved there?

I will not provide a full investigation here, but it seems that high possessors are not necessarily derived through movement, as both positions can be occupied.

- (147) Priidu kaks Kärdi pilti
 Priit.GEN two Kärt.GEN picture.PAR
 ‘Priit’s two pictures of Kärt.’

Examples like these have been accepted without hesitation by my speakers, but naturally-occurring examples seem to be harder to come by. Examples do exist, they are simply infrequent: in both the PARLIAMENT and BALANCED corpora, which have a combined total of roughly 28 million words, I found fewer than 20 examples. One example is given below.

- (148) Eestimaa Rahvaliidu **fraktsiooni** kaks **otsuse** eelnõu ... seisa-vad
 E.R.GEN faction.GEN two.NOM conclusion.GEN bill.PAR stand-3PL
 majanduskomisjoni-s.
 economic.commission-INE

‘The Eestimaa Rahvaliid faction’s two draft bills got stuck in the economics commission.’

Such examples would be difficult to describe if possessors in the high position had to originate in a lower position. Note as well that two possessors are possible independent of the presence of a numeral. Recall the examples from nominalizations, repeated below.

(44) lapse pidev panni-de löö-mine
 child.GEN continuous.NOM pan-PL.GEN hit-NMLZ
 ‘the child’s constant banging of pans’

(45) emis-te päevane proteiini tarbi-mine
 sow-PL.GEN diurnal.NOM protein.GEN consume-NMLZ
 ‘the sows’ diurnal consumption of protein’

(BALANCED)

In these examples, there are two possessors, but no numeral. Thus, I tentatively assume that there are at least two available merge positions for possessors, leaving a more detailed investigation of Estonian possessors for another time. However, I note that a movement-based analysis for possessors would also be compatible with the key aspects of my proposal.

As for adjectives, it certainly seems to be the case that this higher position is a marked position, and some adjectives can more easily surface in the higher position than others. For example, ordinals like *viimane* ‘last’ or *esimene* ‘first’ can appear in either position easily.

- (149) a. viimase-d neli lehekülge
 last-PL 4 page.PAR
 ‘the last four pages’
- b. neli viimas-t lehekülge
 4 last-PAR page.PAR
 ‘four last pages’

A tantalizing hypothesis is that there is a semantic distinction between the two adjectival positions, but it is not yet clear to me what this difference is. Erelt (1986) does not discuss the high position in his book on the syntax of adjectives. On the basis of examples like (149), one might conjecture that only adjectives which are not gradable can occupy the high position. However, a minimal pair involving the adjective *ilus* ‘beautiful’ is provided by Erelt et al. (1993b).

- (150) a. nee-d viis ilusa-t maja
 these-PL 5 beautiful-PAR house.PAR
 ‘these five beautiful houses’

- b. nee-d ilusa-d viis maja
 these-PL beautiful-PL 5 house.PAR
 ‘these beautiful five houses’

Unfortunately, there is no discussion of their context of use. I will leave the analysis of the high adjective position as an open issue, but in the interest of presenting a more complete picture, I will make two more observations. First, note that superlatives can also occupy both positions easily.

- (151) a. Eesti **kõige suure-ma-d** kolm linna
 Estonia.GEN all.GEN big-CMPR-PL.NOM three.SG.NOM town.SG.PAR
 ‘Estonia’s largest three cities’
- b. Eesti kolm **kõige suure-ma-t** linna
 Estonia.GEN three.SG.NOM all.GEN big-CMPR-SG.PAR town.SG.PAR
 ‘Estonia’s three largest cities’

This fact is not localized to Estonian. Abels & Neeleman (2012) observe that, more generally, word order between adjectives and numerals is more flexible if the adjective is a superlative.

Second, this distinction does not seem to be necessarily connected with definiteness, as DPs in existentials can have adjectives in either position.⁵¹

- (152) Aardla tänava-l seis-i-d **rohelise-d** kümme maja.
 Aardla.GEN street-ADE stand-PST-3PL green-PL 10 house.PAR
 ‘There stood 10 green houses on Aardla street.’
- (153) Aardla tänava-l seis-i-s kümme **rohelis-t** maja.
 Aardla.GEN street-ADE stand-PST.3SG 10 green-PAR house.PAR
 ‘There stood 10 green houses on Aardla street.’

Again, it does not matter how we analyze the high adjective position (or its relationship to the low adjective position) for the analysis I propose here. It is enough that this position exists. In order to investigate the question of adjective positions more thoroughly, we would need to have a careful understanding of the semantics and pragmatics of the higher position, which is beyond the scope of the current investigation. I will leave this analysis as an unresolved issue here.

The head-complement structure proposed in (146) for the typical Estonian NNC gives us a window into some of its core syntactic properties. First, the NP⁺ can contain possessors

⁵¹Again, the high position is pragmatically marked, though the precise details surrounding the constraints are still unclear to me. One possible context that supports the high position would be as an answer to the question *How many green houses are on Aardla street?*, where the color of the houses is a more salient issue in some sense.

two). Yet there are clearly two elements marked for number in these constructions. Danon's suggested resolution to this puzzle is that the number-marking on the numeral is due to concord. Again, I will reserve the formal account of number-concord for the next chapter, but that will be my proposal for these constructions as well.

But we are left with an apparent conspiracy. Estonian (and Finnish) NNCs alternate between a head-complement structure in the absence of any plural-marking and an agreeing specifier-head structure when plurality is marked. Why, then, should it be impossible to have either of the following structures?

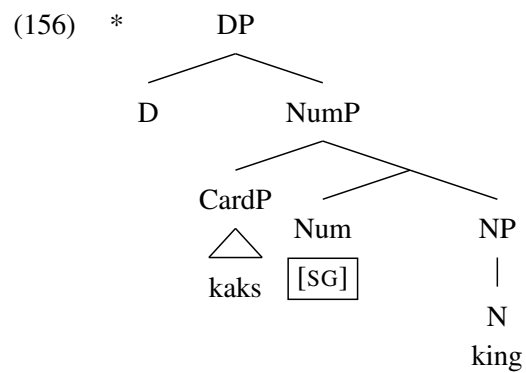
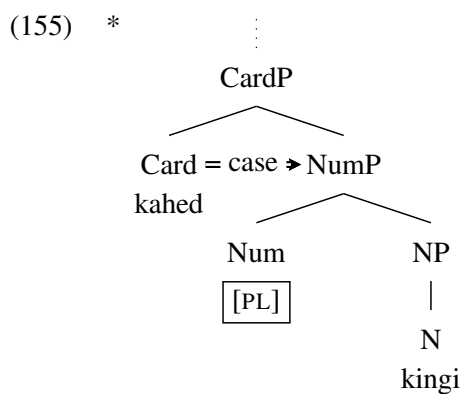

In (155), we have a head-complement structure where both the numeral and the noun are marked plural. I assume that case-marking would be evidence of such a structure (i.e., partitive marking on the head noun). In (156), we have a specifier-head structure with a singular number value. In this structure, there is no case-marking. The only difference between these structures and their grammatical variants is that the number values have been switched.

Danon's tentative suggestion is that "having an embedded NumP which is both plural and partitive might ... be blocked either for semantic reasons or due to a structural competition for the Num position, making [the recursive structure in (155)] ungrammatical." I will return to the semantic rationale for this kind of blocking momentarily, but the syntactic suggestion seems to be that [PARTITIVE] and [PLURAL] are competing for the same syntactic position, as schematized in (157).

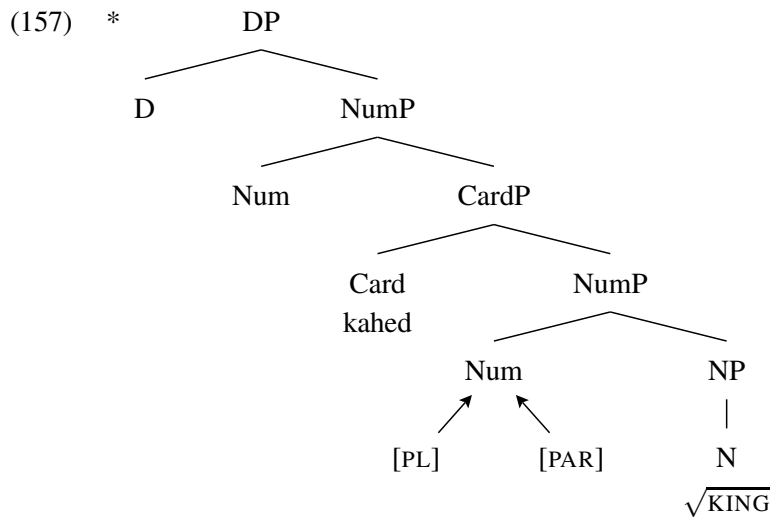

This seems to go against his view of partitive case in NNCs as being assigned by the numeral. Furthermore, we have independent evidence that there is no inherent incompatibility between [PARTITIVE] and [PLURAL], as partitive plural nominals are commonplace outside of NNCs.

- (158) a. Eesriide taga on inimesi.
 curtain.GEN behind be.3 people.PL.PAR
 ‘There are people behind the curtain.’ (Nemvalts 1996:43)
- b. Heiko söö-b õunu.
 H.NOM eat-3SG apple.PL.PAR
 ‘Heiko is eating apples.’

The subject of an existential can be partitive and plural, as in (158a), and verbal objects are also frequently partitive and plural (158b). Thus, if [PARTITIVE] and [PLURAL] are intended to be incompatible in structures like (157), then it must be for reasons particular to that structure rather than general incompatibility between the features [PARTITIVE] and [PLURAL].

2.4.4.1 A partial solution

The literature on cardinal numeral semantics can take us part of the way to a solution for the apparent impossibility of structures like (155). The question boils down to how we treat the difference between languages like Hungarian, where nouns are singular when used with cardinals, and languages like English, where nouns are plural in the same context.

- (159) három gyerek / *három gyerek-ek
 three child / three child-PL

‘three children’

(Hungarian, Farkas & de Swart 2010)

(160) *three child / three child-ren

Importantly, in the absence of cardinals, there is no discernible semantic difference between plural nouns in English and Hungarian (Farkas & de Swart 2010). For example, while plural-marked nouns typically indicate a cardinality greater than 1, in downward-entailing contexts, they simply mean at least 1. This is true of both Hungarian and English.

(161) Plural nouns with inclusive reference (Farkas & de Swart 2010:9):

- a. Láttál valaha lov-ak-at?
see.PST.II ever horse-PL-ACC
‘Have you ever seen horses?’
- b. Anna nem láttot lov-ak-at.
Anna not see.PST horse-PL-ACC
‘Anna hasn’t seen horses.’
- c. Ha láttál valaha lov-ak-at, szólj.
if see.PST.II ever horse-PL-ACC say.IMP
‘If you have ever seen horses, say so.’

In each of these cases, the plural noun *lovakat* ‘horses’ is used to indicate one or more horses. For instance, (161b) claims that Anna has not seen one or more horses. Given these similarities, it would seem difficult to formulate an analysis of the contrast in number-marking in NNCs ((159) and (160)) on the basis of a putative difference in the semantics of plurality in the languages. The previous literature does not advocate for such an approach.

Ionin & Matushansky (2006) treat the singular pattern (exemplified by Hungarian) as the only structure that can be interpreted, due to a constraint (a presupposition) on the kinds of things that can be counted. I refer the reader to their paper for in depth discussion of the constraint, but the basic idea is that the complement of a cardinal must denote a set of individuals such that every member of the set has the same cardinality. This is true for a singular count noun, which denotes a set of individuals. But the members of the denotation of a plural noun do not necessarily all have the same cardinality. This could explain why (155) is ruled out.

However, Ionin & Matushansky must then say something special to account for languages (like English) where the noun in an NNC clearly bears plural morphology. They suggest that the plural-marking is not present syntactically or semantically— that is to say, it is not an indicator of the presence of plural semantics. Instead, it arises due to a kind of semantic concord

“where part of [an NP] agrees with the entire [NP]” (Ionin & Matushansky 2006:17). The technical details of this proposal are not developed in detail in their paper, but the idea is clear: plural-marking on nouns in NNCs is not the same as plural-marking on nouns in the absence of numerals.

Farkas & de Swart (2010) propose a unidirectional OT analysis of the number-marking differences between Hungarian and English that I believe has a similar spirit to the suggestion of Ionin & Matushansky. The intuition is that, if a DP is supposed to have sum reference, then that sum reference has to be overtly marked. This is dictated by a constraint they call FPL, defined below:

(162) FPL: Sum reference must be encoded in the functional structure of the nominal (Farkas & de Swart 2010:44).

This constraint is in competition with a constraint against functional structure in nominals, *FUNCTN.

(163) *FUNCTN: Avoid functional structure in the nominal domain (Farkas & de Swart 2010:20)

In the absence of a numeral (or some other quantificational element), the only way to indicate sum-reference is by plural-marking, and thus nouns in definite DPs with sum reference must be plural in Hungarian.

(164)

$\exists!x: [x \in \text{SUM} \ \& \ *CHILD(x)]$	FPL	*FUNCTN
<i>a gyerek</i> ‘the child’	*	*
☞ <i>a gyerekek</i> ‘the child.PL’		**

Because of the need to indicate sum reference overtly (due to FPL), only the plural form is possible for the interpretation given in the input in (164).

Farkas & de Swart (2010) assume that FPL is a general constraint— it can be satisfied by any element that entails sum reference (in addition to [PL]). Thus, numerals (which they analyze as determiners) can satisfy FPL. This means the NumP’s [PL] feature is no longer necessary if a numeral is present. More strongly, though, *FUNCTN actually forbids its presence:

(165)

$\exists!x: [x \in \text{SUM} \ \& \ * \text{CHILD}(x)]$	FPL	*FUNCTN
☞ <i>haróm gyerek</i> ‘three child’		*
<i>haróm gyerekek</i> ‘three child.PL’		**

The claim is that, because using NumP’s [PL] feature is redundant and thus less economical, the version with plural-marking is ruled out. Note that this analysis requires the possibility of comparing fully-formed outputs as possible expressions of some semantic meaning, with a general preference for structural economy unless some other aspect of the language’s grammar demands additional structure (e.g., FPL). In Hungarian, the effects of structural economy only emerge when a numeral (or other quantifier entailing sum reference) is present.

In order to account for English-type languages, Farkas & de Swart (2010) propose another constraint that requires plural-marking in nominals with plural reference. This constraint is called MAXPL.

(166) MAXPL: Mark with [PL] nominals that have sum reference.

Ranking MAXPL above *FUNCTN yields an English-type pattern.

(167)

$\exists x: [* \text{CHILD}(x) \ \& \ x \geq 3]$	FPL	MAXPL	*FUNCTN
three child		*	*
☞ three children			**

Thus, the difference between Hungarian and English is cast as a matter of morphological economy: English prefers marking nominals with sum referents, and Hungarian does so only when necessary.

I believe these approaches are on the right track, but they need to be further developed, as they are based on examples with only a noun and a numeral. It is quite unclear to me how Farkas and de Swart’s analysis extends to examples in Estonian involving demonstratives, where it would seem the language simultaneously prefers and disprefers economy.

(168) *nee-d* *kolm* *las-t*
 this-PL.NOM 3.NOM child-(SG.)PAR
 ‘these three children’

Estonian nouns are singular in NNCs, like Hungarian. Thus, we might hypothesize that Estonian prioritizes morphological economy (i.e., MAXPL is ranked low (169)). However, higher

elements like demonstratives must be plural, which seems to go against the hypothesis that Estonian prioritizes marking plural (i.e., MAXPL is not ranked low (170)). Neither order predicts the attested pattern.⁵²

(169)

ιx : [$*\text{CHILD}(x)$ & $ x \geq 3$]	FPL	*FUNCTN	MAXPL
☞ <i>see kolm last</i> ‘this 3 child’		**	**
<i>see kolm lapsi</i> ‘this 3 child.PL’		***	*
☹ <i>nee-d kolm last</i> ‘these 3 child’		***	*
<i>nee-d kolm lapsi</i> ‘these 3 child.PL’		****	

(170)

ιx : [$*\text{CHILD}(x)$ & $ x \geq 3$]	FPL	MAXPL	*FUNCTN
<i>see kolm last</i> ‘this 3 child’		**	**
<i>see kolm lapsi</i> ‘this 3 child.PL’		*	***
☹ <i>nee-d kolm last</i> ‘these 3 child’		*	***
☞ <i>nee-d kolm lapsi</i> ‘these 3 child.PL’			****

The constraints MAXPL and *FUNCTN are essentially opposites. Notice that each candidate in the tableaux above has the same number of total violations of MAXPL and *FUNCTN; they are just distributed differently. Any choice that reduces violations of MAXPL increases violations of *FUNCTN, and vice versa. In developing the analysis of Farkas & de Swart (2010) further, it is likely that relativized versions of MAXPL (and perhaps FPL) would need to be implemented. I will not develop such an account here, but leave this matter open for further research.

Instead, I tentatively propose that this can be implemented in terms of selection. We already know that the head-complement structure and the specifier-head structure utilize different heads in the nominal extended projection. In the head-complement structure, it is the numeral itself which selects its NumP complement. In the specifier-head structure, there is a functional projection which (i) hosts a numeral in its specifier, and (ii) selects its NumP complement. Thus, under a selection account, what I conclude is that numeral heads select only NumPs with a head that is [SINGULAR] (or unmarked for number), but the functional head hosting a numeral selects only NumPs whose head *has* a [PLURAL] feature.

⁵²I represent the semantic contribution of the demonstrative by replacing \exists with ι . This is an arbitrary choice—the precise semantic contribution of \exists is immaterial in the present discussion.

2.5 Conclusions and Further Directions

The structure for Estonian DPs that I will assume for the remainder of this dissertation is given below.

- (171) *kõik* *nee-d* *viis* *inimes-t*
 all.PL.NOM these-PL.NOM 5.NOM person-PAR
 ‘all these 5 people’

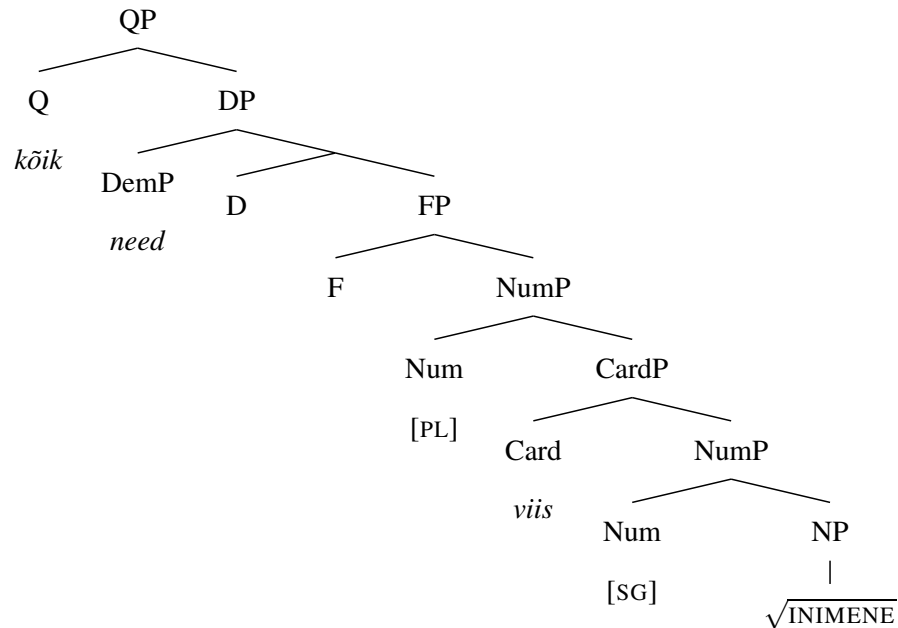

In section 2.2, I argued that the nominal extended projection in Estonian contains DP. In light of this conclusion, I considered and rejected several versions of the Small Nominal Hypothesis, which holds that nominals have less functional structure in languages without articles. This conclusion raises a number of questions about the nature of the syntactic category D^0 , including one that I considered most seriously: what kinds of elements are D^0 heads in a particular language and crosslinguistically? I believe careful and serious investigation of this question will be necessary as research continues to probe the nature of the nominal extended projection.

In sections 2.3 and 2.4, I considered some of the issues involved in analyzing the syntax of numeral-noun constructions. In Estonian, there are two possibilities. In one construction, the addition of numerals to a DP coincides with an additional number value and an additional case value (if the entire NNC is nominative or accusative). In another construction, there is no apparent case assignment, and the numeral shows concord in number, apparently in agreement with

the head noun. I followed Danon (2012) in proposing that these constructions are syntactically different: in the former construction, the numeral is a head in the nominal extended projection. In the the latter construction, the numeral is the specifier of a functional head.

There are a number of empirical areas that warrant a deeper investigation than I gave them here. First, there are a number of analytical issues surrounding the investigation of possessors that I did not address here. For example, it is clear that there are at least two syntactic positions for possessors, but I did not investigate whether there were restrictions on when they could be used or on the kinds of thematic relations available in each position. Second, it is clear that there are two positions for adjectives in the language, but it is not clear what the syntactic and semantic constraints on the two positions are. More broadly, the literature on number-marking in numeral-noun constructions has largely focused on whether the noun is marked for plural or not. The investigation here reveals that more attention needs to be paid to other elements within the DP. The fact that there are both singular and plural elements in Estonian numeral-noun constructions suggest that a more nuanced approach to the syntax and semantics of number-marking is necessary. These questions are all worthy of investigating, but I set them aside for now.

With a syntactic structure for Estonian DPs in place, we are now ready to investigate the patterns of concord found in them. This will be the focus of the next chapter.

- (172) Numerals can show concord:
- a. fjór-a
four-ACC.M.PL
snigl-a
snail-ACC.M.PL
'four snails (ACC)' (Icelandic)
- b. nelja-ks teo-ks
four-TRL snail-TRL
'for/into four snails' (Estonian)
- (173) Demonstratives can show concord:
- a. þess-um
these-DAT.M.PL
snigl-um
snail-DAT.M.PL
'these snails (DAT)' (Icelandic)
- b. nen-de-st tigu-de-st
this-PL-ELA snail-PL-ELA
'from these snails' (Estonian)

In (172b), *nelja-ks* 'four-TRL' bears the same case- and number-marking as the noun *teo-ks* 'snail-TRL'. In (173b), the demonstrative *nen-de-st* 'this-PL-ELA' bears the same case- and number-marking as the noun *tigu-de-st* 'snail-PL-ELA'.

The focus of the rest of this dissertation will be the concord system of Estonian. A full list of the word classes that show concord in Estonian is given in Table 3.1. Including the noun,

CATEGORY	ESTONIAN (ADESSIVE)	ENGLISH
NOUN	<i>tigu-de-l</i>	snails (adessive)
ADJECTIVE	<i>kollas-te-l tigu-de-l</i>	yellow snails (adessive)
NUMERAL	<i>nelja-l teo-l</i>	four snails (adessive)
DETERMINER	<i>millis-te-l tigu-de-l</i>	which snails (adessive)
DEMONSTRATIVE	<i>nende-l tigu-de-l</i>	these snails (adessive)
QUANTIFIER	<i>kõiki-de-l tigu-de-l / kõigi-l tigu-de-l</i>	all snails (adessive)

Table 3.1: Elements showing concord in Estonian

there are six descriptive categories that show concord in Estonian. By *show concord*, I mean the element must bear case- and/or number-marking along with the noun. If we think of the noun as the controller of concord, then there are as many as four targets in Estonian. I will refer to the targets (i.e., the elements showing concord) as CONCORDING ELEMENTS, or simply CEs.

The system of concord in Estonian is quite rich, but there are categories that do not inflect in Estonian but do inflect in some other languages. For example, some possessors inflect in Icelandic (see (174)) and French (see (175)), but possessors do not inflect in Estonian.¹

¹One possible exception is the reflexive possessive pronoun *oma*, which does appear to inflect in some cases. (e.g., *oma-l aja-l* 'OMA-ADE time-ADE'). However, I believe the agreeing *oma* examples actually involve a homophonous adjective meaning 'own'. Evidence in support of this comes from the fact that the adjectival *oma* can

(174) Possessors in Icelandic show concord:²

- a. frá hús-i-nu mí-nu
from house-DAT.NEUT.PL-the.DAT.NEUT.PL my-DAT.NEUT.PL
'from my house'
- b. um borg-ar-nir þí-nir
about city-ACC.FEM.PL-the.ACC.FEM.PL your-ACC.FEM.PL
'about your cities'

(175) Possessors in French show concord:

- a. m-on chapeau
my-MASC.SG hat.MASC.SG
'my hat'
- b. s-a maison
your.SG-FEM.SG house.FEM.SG
'your house'

(176) Possessors in Estonian do not show concord:

- a. minu(*-st) maja-st
1SG.GEN-ELA house-ELA
'from my house'
- b. sinu(*-de)(*-ks) linna-de-ks
2SG.GEN-PL-TRL city-PL-TRL
'for/into your cities'

The possessors in French and Icelandic show concord just like any other CE. However, it is not possible for possessors in Estonian to show concord in case or number, as (176) clearly shows. Instead, they are always in genitive case, and they carry their own number value.

co-occur with another possessor, even the homophonous reflexive possessive *oma* (see (i)), although speakers I have consulted prefer to use *enda oma* 'self.GEN OMA' instead.

- (i) See küll või-b vahe-l oma oma pōrsa-d ära õgi-da
this surely can-3SG between OMA OMA piglet-PL.ACC PRTCL chow.down-DA
'In the meantime, this (pig) could surely eat its own piglets.' (BALANCED)

For the moment, I adopt this analysis and assume that possessors in Estonian do not show concord with the possessed noun.

²In modern Icelandic, only three possessors show concord: first-person singular *minn*, second-person singular *þinn*, and the third-person, number-neutral reflexive *sinn*. The first-person plural possessive *vor* also shows concord, but this form is archaic and has been replaced by the invariant genitive form *okkar* of the first-person plural pronoun *við* in the modern language.

Estonian does not have articles, the classic example of an exponent of the category D^0 . Articles often show concord in languages that have concord. Even in English, the indefinite article could be argued to inflect for number.

(177) The English indefinite article shows concord:³

- a. a ladder / *a ladders
- b. *[sɪ] ladder / [sɪ] ladders

Though Estonian lacks articles, I argued in chapter 2 that *wh*-determiners like *milline* ‘which’ are exponents of D^0 . If that is right, then Estonian also has examples of D^0 s showing concord.

It is not just the number of CEs that is remarkable. CEs also occupy a variety of syntactic positions, including heads (in the main spine), specifiers, and possibly adjuncts. The extent to which this is true for such-and-such language depends, of course, on syntactic analyses of the CEs in question. CEs in the head category might include strong quantifiers or determiners. The fact that these show concord is not surprising, as examples of heads agreeing with lower constituents elsewhere are plentiful (for example, T^0 agreeing with a DP). CEs may also occupy specifier position. For example, in chapter 2, I proposed that demonstratives and some numerals occupy specifier positions in Estonian, and both show concord. For their part, possessors have also been argued to occupy specifier positions, and they, too, show concord (see Norris, Mikkelsen & Hankamer to appear and references there). Finally, there is the case of adjectives, which have actually been argued to occupy a variety of syntactic positions: head positions (e.g., Abney (1987), Bernstein (1993)), specifier positions (Cinque 1994), and adjunct positions (Svenonius 1994). I proposed in Chapter 2 that adjectives are adjuncts in Estonian. Adjectives very regularly show concord, and thus, if the adjunct analysis of adjectives is correct, then CEs can occupy adjunct positions as well. It seems to be true that, descriptively speaking, concord is extremely permissive regarding the possible relationships between CEs and the head noun.

The study of concord has ramifications for many domains of linguistic theory, depending on what is assumed about agreement. For example, if one begins with the assumption that existing theories of agreement are correct in their current forms, one may conclude certain things about the syntax of DP-internal elements simply on the basis of their exhibiting concord.

³I use [sɪ] to indicate the phonologically-reduced plural indefinite determiner in English, which cannot be used with singular nouns. It is homographic with another determiner *some*, but this determiner cannot be phonologically reduced. The non-reduced *some* can be used with singular nouns (e.g., *Some guy came looking for you.*).

However, if one begins on the assumption that existing analyses of, e.g., demonstratives or adjectives are right, then one might conclude that existing theories of agreement are not enough in their current form to account for all the kinds of agreement we see in natural language. The analysis I pursue is closer to the second category. In other words, I believe concord is telling us something about agreement in natural language, but not as much about the syntax of CEs.

In this chapter (and the next), I will develop an analysis of number and case concord in Estonian. The concord system in Estonian is very rich and at times, quite complicated. This makes it a good case study for a theory of concord. Broadly speaking, I will argue against the view espoused by some that concord is, in some sense, a DP-internal version of subject-verb agreement (or argument-predicate agreement more broadly). This form of agreement is often formalized via a particular syntactic configuration. Previous theories of subject-verb agreement as a relationship between a head and a specifier have given way to the modern Minimalist view that subject-verb agreement is between a head (e.g., T^0) and a DP in its c-command domain. In contrast, I will propose that concord is largely morphological and not indicative of a relationship between the element bearing features and some other element in its c-command domain. More strongly, I will propose that the syntax of a language with concord is not necessarily any different from the syntax of a language without concord. This difference will only emerge in the morphology.

The proposal is broken into two pieces. First, I adopt explicit mechanisms of feature value spreading or percolation in the ‘narrow syntax’ (Babby 1987, Chomsky 1981, Lieber 1989, Matushansky 2008, 2009, Richards 2012, Selkirk 1982). For the actual spell-out of concord, I adopt a Distributed Morphology approach to agreement, involving the insertion of postsyntactic Agr^0 nodes, and a rule of Feature Copying to copy values onto those Agr^0 nodes from local sources (Kramer 2010, Norris 2012, Noyer 1997). The view of concord that I end with is one where concord marks a kind of membership: CEs inflect for certain features of the constituents that contain them.

The chapter proceeds as follows. In section 3.2, I will consider previous approaches to concord, focusing in particular on analyses based on the syntactic relation Agree (Chomsky 2000, 2001). In section 3.3, I refine the description of concord presented in this initial chapter by investigating concord in numeral-noun constructions in Estonian. As we will see, numeral-noun constructions suggest the description of concord as “agreement with the head noun” is

misguided. In sections 3.4 and 3.5, I will propose my analysis of number and case concord and show specifically how it accounts for the data discussed in section 3.3, although I further explore case concord in the next chapter. I conclude in section 3.6.

3.2 Previous approaches to concord

Nominal concord is a well-known phenomenon, but it has still largely escaped critical theoretical treatment. Sometimes, concord's mention comes along with the suggestions of a possible theoretical analysis. For example, Chomsky's (2001) footnote 6: "There is presumably a similar but distinct agreement relation, Concord, involving Merge alone." Another reference is made to "noun-modifier agreement" in Chung's (2013) article on the syntactic relations behind agreement (and Agree), suggesting that this agreement relation may be different from the kind usually analyzed by Agree (see also the discussion by Anderson (1992)). In this chapter, I will develop an analysis of concord, ultimately agreeing with the suggestions by people like Chomsky and Chung that nominal concord is of a different nature than more familiar kinds of agreement.

The proposals that I am aware of do not take this approach— all those that I am aware of aim to extend theories of (subject-verb) agreement to concord. This extends across many different theories of agreement:

- **Feature-Checking:** Carstens 2000, Mallen 1997
- **Agree:** Baker 2008, Carstens 2001, 2011, 2013, Danon 2011, Kramer 2009, Sigurðsson 2004, Toosarvandani & Van Urk 2012
- **Spec-Head agreement:** Koopman 2006, Sigurðsson 1993
- **Feature Unification:** Grimshaw 1991/2005, Svenonius 1993, Wechsler & Zlatic 2003⁴

This is certainly not an unreasonable move, especially given the strands of research drawing parallels between the nominal and clausal domains (Abney (1987), Szabolcsi (1994), a.o.). If

⁴In actuality, Svenonius and Wechsler & Zlatic do not only make use of Feature Unification, as adjectival concord is enforced by selection on the assumption that adjectives are specifiers and that specifier features do not unify with the features of the head. I do not believe adjectival concord behaves differently from other instances of nominal concord in any discernible way. Thus, an ideal account would analyze adjectival concord in the same way as concord shown by other CEs.

it can be shown that the same agreement operation is active in both the nominal and clausal domain, then this would be another example of a nominal-clausal parallel.

The implicit assumption in such approaches is that concord and subject-verb agreement are in some deep sense very similar. In analyzing concord and subject-verb agreement with the same agreement mechanism, any differences between the two need to be connected to other independently observable differences between the nominal and clausal domains. Of course, this task would be straightforward if there were a high degree of similarity between concord and subject-verb agreement. I contend that this is not the case. From a descriptive point of view, there are few similarities between concord and subject-verb agreement beyond the fact that they are both forms of agreement involving ϕ -features.

3.2.1 Comparing concord and subject-verb agreement

There are a number of differences between concord and subject-verb agreement that cast doubt on the notion that the two are in some sense the same process. I will discuss four such differences here. First, there is a difference in the number of loci of agreement expression. It is quite common for concord to have multiple loci of expression. For example, all four elements in the following Estonian examples show concord for number and case:

(178) kõiigi-s nei-s raske-te-s küsimus-te-s
 all.PL-INE this.PL-INE hard-PL-INE question-PL-INE
 ‘in all these hard questions’ (BALANCED)

(179) kõiik see ilus maailm
 all.NOM this.NOM beautiful.NOM world.NOM
 ‘all this beautiful world’ (BALANCED)

In (178), every element bears plural number and inessive case, and in (179), they are all singular and nominative.

In contrast, Estonian subject-verb agreement is expressed in one and only one place in the typical cases.⁵ Sentences involving auxiliary verbs in Estonian only show agreement on the auxiliary—the main verb surfaces in an invariant participial form. Accompanying adverbs are also invariant.

⁵The exceptions are in negated indicatives, where agreement is apparently absent, and negated imperatives, where agreement is present twice. This is the subject of ongoing research, but see Norris & Thompson 2014 for some preliminary thoughts.

- (180) a. Heiko on kiiresti lahku-nud.
 H.NOM be.3 quickly leave-PST.PCPL
 'Heiko has quickly left.'
- b. * Heiko on (kiiresti) lahku-b.
 H.NOM be.3 (quickly) leave-3

This may not be an insurmountable difference, as there are languages where constructions like (180b) are the norm. They are well-documented in Bantu (Carstens 2001, Henderson 2006) and have also been observed and analyzed in Ibibio (Baker & Willie 2010) and Hindi (Bhatt 2005). Bantu languages are also well-known for their concord systems. The observed facts in Estonian are puzzling against this backdrop, because Estonian has a rich system of concord but subject-verb agreement is only expressed once. If there is a deep similarity between subject-verb agreement and nominal concord, we should wonder why Estonian has comparatively sparse verb agreement given its system of concord.

Second, as I noted in the introduction, it is not just the number of elements showing concord that is remarkable, but they also occupy distinct syntactic positions. Whether or not this is the case depends on syntactic analyses of the categories in question, but I contend that concord may be seen on heads (e.g., determiners, strong quantifiers), specifiers (e.g., numerals, demonstratives, possessors), and adjuncts (adjectives). As we just saw, adverbs do not agree in Estonian, and in fact, there are very few examples of agreeing adverbs in the literature. It is generally assumed that adverbs are syntactically similar to adjectives, and if such a characterization is on the right track, the failure of adverbs to show agreement is telling. Adjectives regularly show concord, but adverbs apparently agree only rarely.

Third, the relationship between the origin of features and the location of their ultimate expression is different. In subject-verb agreement, a verbal element expresses nominal features of one of its arguments. The features are expressed on elements of verbal projection, but they originate in the nominal projection. Subject-verb agreement is a relationship between two different extended projections (in the sense of Grimshaw 1991/2005). In (nominal) concord, a nominal element expresses features of the same nominal extended projection that contains it. It is not a relationship between two different extended projections, but a relationship between an extended projection and its members. The features are born in a particular nominal extended projection, and they are expressed there.

Finally, it has been shown that there is some kind of connection between subject-verb agreement and case. For example, in Estonian, only nominative arguments can control verb agreement (Erelt et al. 1993b, 2000).

- (181) a. Õue-s mäangi-s lapsi.
 yard-INE play-PST.3SG children.PL.PAR
 ‘There were children playing in the yard.’
- b. * Õue-s mäangi-si-d lapsi.
 yard-INE play-PST-3PL children.PL.PAR
 Intended: ‘There were children playing in the yard.’
- (182) a. * Õue-s mäangi-s lapse-d sulgpalli.
 yard-INE play-PST.3SG children-PL.NOM badminton.PAR
 Intended: ‘There were children playing badminton in the yard.’
- b. Õue-s mäangi-si-d lapse-d sulgpalli.
 yard-INE play-PST-3PL children-PL.NOM badminton.PAR
 ‘There were children playing badminton in the yard.’

In (181), the partitive plural *lapsi* does not result in a plural verb, and in (182), the nominative plural *lapsed* must trigger plural agreement on the verb.

In the original formulation of Agree (Chomsky 2000, 2001), the relationship was one-to-one: an element agreeing with T^0 bore nominative case, and vice versa. It has been argued that the relationship between nominative case and verb agreement is not as tight as that formulation of Agree predicts, but there is still some connection between case-marking and subject-verb agreement. For example, recent work by Bobaljik (2008), Preminger (2011) has advocated for the view that probes like T^0 may be sensitive to the case values of possible goals, such that they cannot agree (at least, morphologically) with an element bearing any other case but nominative. I am aware of no such descriptive link between case and concord. Concord is not connected to the assignment of a particular case, nor is there a “failure of concord” if a CE is marked with some case or other.

The differences just discussed are given in brief in Table 3.2. To be sure, these differences do not necessarily mean that the phenomena are not analyzable using the same theoretical machinery. However, extending the mechanisms used for subject-verb agreement to analyze concord certainly raises questions related to these domains. At the very least, it does not seem to be a foregone conclusion that concord and subject-verb agreement are two sides of the same coin. I believe that we should take seriously the differences between subject-verb agreement

	SUBJECT-VERB AGREEMENT	CONCORD
NUMBER OF LOCI OF EXPRESSION (IN ESTONIAN)	one	many
STRUCTURAL POSITION OF AGREEING ELEMENTS	head	head, specifier, adjunct
FEATURE ORIGIN	external	internal
CASE-DEPENDENCE	yes	no

Table 3.2: A comparison of subject-verb agreement and concord

and concord. In order to focus this investigation, I will turn the discussion towards what I take to be the the standard Minimalist view of subject-verb agreement— namely, that it is predicated on the syntactic relation Agree. I contend that the behavior of concord is not what we would expect if concord is a reflex of Agree. I will turn to a discussion of this now.

3.2.2 Agree and kinds of agreement

One part of the theory of agreement predominating in work within the Minimalist framework is Agree, a version of which is given below.

- (26) A probe X establishes an Agree relation with a goal YP, where:
- a. X c-commands YP,
 - b. X lacks values for uninterpretable features that can be supplied by the values of matching features on Y,
 - c. Y lacks values for uninterpretable features that can be supplied by X,
 - d. No potential goal intervenes between X and Y,
 - e. X and Y are in the same phase.

Agree supplies the values of each category’s uninterpretable features from matching features of the other category, with the two features coalescing into a single shared feature.

The main difference between this and Agree in its original formulation is that (26) is the feature-sharing version of Agree as motivated and developed by Frampton & Gutmann (2006) and Pesetsky & Torrego (2007). This is the version used by Danon (2011) and Kramer (2009) to analyze concord.

The hypothesis that morphological agreement and Agree always coincide has led to two intertwined consequences, as discussed by Chung (To Appear). On the one hand, it has driven a large amount of productive research on morphological agreement (among other related phenomena). On the other hand, Agree as defined in (26) has ultimately not been enough to explain the patterns that have been uncovered— that is, if one assumes the hypothesis that morphological agreement and Agree must coincide— and thus there have been a range of modifications to (26) that are still intended to be the same operation. Chung identifies a number of these:

- Split feature checking (Alexiadou & Anagnostopoulou 2006, Anagnostopoulou 2005)
- Agree that probes (down and then) up (Baker 2008, Béjar & Rezac 2009)
- Multiple Agree (Hiraiwa 2000, Nevins 2007, 2011)
- Agree that probes for marked or contrastive values of a feature (Nevins 2007)
- Obligatory Agree whose failure does not stop the derivation from proceeding (Preminger 2011)
- Agree that allows the case-marking of potential goals to “[play] a role in whether or not they will actually be targeted” (Preminger 2011:119, building on Bobaljik 2008)

Concord is one such domain that has required adopting one of the modifications to Agree.

The range of options available to Agree in the literature make it somewhat difficult to argue against such analyses on a purely empirical basis. In other words, it is probably possible to modify Agree such that concord can be viewed as a reflex of this syntactic operation, but I will not develop such an account here. What I aim to show in this section is that some of the fundamental properties of concord do not show the hallmarks of Agree. If we reject the hypothesis that Agree and morphological agreement track each other one to one—or more specifically, that morphological agreement requires a syntactic Agree relationship—then we should carefully consider what an Agree-based analysis reveals about the nature of concord.

3.2.3 Adjectival concord and Agree

One of the structural conditions imposed on Agree is c-command. In a typical Agree relation, the probe must c-command the goal. If there is supposed to be an Agree relation between A^0

and N^0 , e.g., because A^0 has uninterpretable ϕ -features ($[u\phi]$) and N^0 has ϕ -features ($[\phi]$), it is not obviously true that the c-command relation holds in such a configuration.

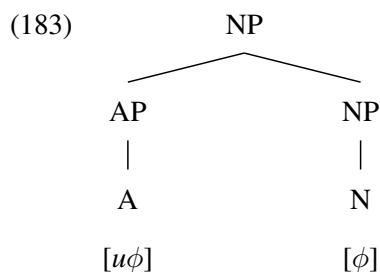

Under a definition of c-command where “a node c-commands its sister and everything its sister dominates,” it would seem that A^0 does not c-command anything in (183). If that is true, then how could A^0 come to acquire the ϕ -features present on N^0 ?

Of course, proposals have been made to address this apparent problem. To wit, it has been proposed that phrases can serve as probes (Danon 2011). The AP in (183) certainly appears to be in a position to c-command N^0 .⁶ Note that (183) does not appear to be compliant with current conceptions of phrase structure. Concretely, it does not conform to principles of Bare Phrase Structure. Proposing that AP may be a probe is essentially identical to assuming a version of (183) that is more in line with Bare Phrase Structure, where the adjective in (183) could be simultaneously minimal and maximal as represented in (184).

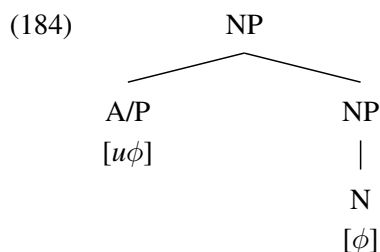

Thus, it seems clear that the theory of phrase structure assumed matters for evaluating theories of concord as Agree.

Another approach builds on the work of Béjar & Rezac (2009) and proposes that the relationship between a c-commanding probe and a c-commanded goal encoded in Agree is only a

⁶I would like to note that whether this is true crucially depends on (i) our assumptions about adjunction structures and (ii) our assumptions about the proper syntax of adjectives. The research that directly addresses adjectival concord seems to assume that adjectives are adjoined and can c-command their attachment site. So, in (183), the AP node c-commands its NP sister and the N^0 head. As discussed in chapter 1, this assumption is not shared by everyone, but I will assume it for the sake of argument in this section.

preference. Under this view, adjectival heads search their c-command domains for suitable goals as normal. Upon finding nothing to Agree with, the search continues upward, i.e., the probe search for a c-commanding goal rather than a c-commanded goal (Toosarvandani & Van Urk 2012, Carstens 2013). Under these proposals, adjectives rely on a higher head (e.g., D^0) to acquire the features of the N^0 indirectly. This is represented in the structure in (185).

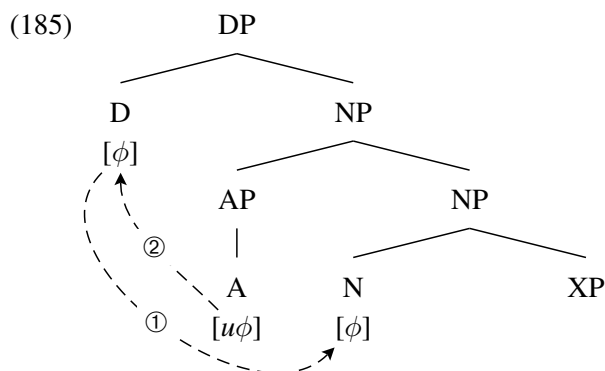

First, D^0 establishes Agree with N^0 . Then, A^0 establishes Agree with D^0 . The end result is that D^0 , A^0 , and N^0 bear the same set of ϕ -features.

Importantly, these proposals are discussed in the context of simple adjectival phrases, i.e., those containing only adjectival heads. However, as we know, attributive adjectives can have complements in some languages. Estonian is one such language. Many adjectival complements look like PPs, as in (186) and (187).

(186) [oma poega-de üle] uhke naine
 [REFL.POSS son-PL.GEN over] proud.NOM woman.NOM
 ‘a woman proud of her sons’

(187) [tugeva-te-le mees-te-le] kade noormees
 [strong-PL-ALL man-PL-ALL] envious.NOM young.man.NOM
 ‘a young man envious of strong men’

I assume the phrases in brackets in (186) and (187) are PPs— the phrase in (186) actually contains the postposition *üle* ‘over’. Assume for the moment that these PPs are complements. Bearing in mind the proposal that adjectives probe down first, observe that the adjective in such examples cannot show concord with its complement.

(188) * [tugeva-te-le mees-te-le] kadedad / kadedate noormees
 [strong-PL-ALL man-PL-ALL] envious-PL.NOM / envious-PL-ALL young.man.NOM

It is not possible for the adjective *kade* to express the features of the DP in its complement. It must always show concord with the nominal it modifies. However, these complements are PPs, and we have independent reason to believe that agreement with DPs inside of PPs might be ruled out (Rezac 2008, Preminger 2011, Toosarvandani & Van Urk 2014). This confound means that the example in (188) may not be revealing. However, there is a class of adjectives in Estonian which does not share this confound, and I will turn to them now.

3.2.3.1 Participial adjectives in Estonian

To my mind, the most compelling examples of complex adjective phrases in Estonian involve what are traditionally called participles. These are the words in bold in (189) and (190).

(189) Kuidas lähene-da [salati-t **söö-va-le**] naise-le?
 how approach-DA salad-PAR eat-PRS.PCPL-ALL woman-ALL
 ‘How does one approach a woman (who is) eating salad?’

(190) [piiritletud aspekti-ga tegevus-t **väljenda-va**] verbi
 bounded aspect-COM action-PAR express-PRS.PCPL.GEN verb.GEN
 ‘of a verb expressing a telic action’ (Erelt et al. 1993b:33)

Given that the term *participle* is also used for elements that are not adjectives, I will use the more specific term PARTICIPIAL ADJECTIVE (or PA) to refer to this class of adjectives. In (189), the PA is *sööv* ‘eating’, based on the verb *sööma* ‘eat’. In (190), the PA is *väljendav* ‘expressing’, based on the verb *väljendama* ‘express’. I will propose that PAs are the heads of the phrases enclosed in brackets in (189) and (190). Note that both PAs show concord with the nouns they are modifying (*naisele* ‘woman-ALL’ in (189), *verbi* ‘verb.GEN’ in (190)).

PAs are based on verbal roots, but they have the external distribution and behavior of adjectives. For example, they appear in between numerals and the head noun, just like normal adjectives.

(191) a. kaks **rääki-va-t** pea-d
 two speak-PRS.PCPL-PAR head-PAR
 ‘two talking heads’ (BALANCED)

b. kaks **kilju-va-t** tüdruku-t
 two yell-PRS.PCPL-PAR girl-PAR
 ‘two yelling girls’ (BALANCED)

Just like adjectives in between numerals and nouns, the PAs *rääkivat* ‘speaking’ and *kiljuvat* ‘yelling’ are marked with partitive case in (191). The only other elements that can appear between the numeral and the noun are possessors, but possessors are invariantly marked with genitive case.

Another adjectival property of PAs is their ability to appear in comparative and superlative constructions. The comparative morpheme in Estonian is *-(a)m*; some comparative PAs are shown in (192).

- (192) *püsi-va-m* / *liiku-va-m* / *meeldi-va-m*
 persist-PRS.PCPL-CMPR / move-PRS.PCPL-CMPR / please-PRS.PCPL-CMPR
 ‘more persistent’ / ‘more mobile’ / ‘more pleasing’

Estonian has both a synthetic superlative and an analytic superlative. In the analytic superlative, the comparative form is preceded by the genitive form of *kõik* ‘all’.⁷ The analytic superlative is much more common, especially in the spoken language. Some superlative PAs are shown in (193).

- (193) a. *süga-va-im* / *sobi-va-im*
 scratch-PRS.PCPL-SUPER / suit-PRS.PCPL-SUPER
 ‘most deep/profound’ / ‘most fitting/suitable’
- b. *kõige süga-va-m* / *kõige sobi-va-m*
 all.GEN scratch-PRS.PCPL-CMPR / all.GEN suit-PRS.PCPL-CMPR
 ‘most deep/profound’ / ‘most fitting/suitable’

The ability to form comparatives and superlatives is thus another property that adjectives and PAs share. However, PAs also have some verbal properties that stretch beyond the fact that they are formed from verbal roots.

3.2.3.2 Verbal properties of participial adjectives

To begin, note that PAs come in “present” and “past” variants. The PAs we have seen so far are traditionally called “present” participles. However, the semantics of present PAs does not

⁷A reasonable hypothesis about what the genitive-marked *kõik* is doing in the superlative is that it is the standard of comparison: ‘A⁰-er than everything’. However, standards of comparison are not marked with genitive, they are marked with elative case, e.g., *puu-st pikem* ‘tree-ELA taller’. I will not provide a syntactic analysis of the superlative here, but this seems like an observation worth making for the sake of future research.

appear to be connected to tense, but aspect. For example, when used in a past tense sentence, present PAs indicate contemporaneous action.

(194) Politseipatrull pida-s [kummalis-t grafiti-t **tege-va**]
 police.patrol.NOM hold-PST.3SG strange-PAR graffiti-PAR do-PRS.PCPL.ACC
 poisi kinni.
 boy.ACC closed
 ‘The police patrol detained a boy (who was) doing strange graffiti (i.e., they caught him in the act).’

(195) Ema praga-s [kõiki kooke **söö-va**] poisi
 mother scold-PST.3SG all.PL.PAR cake.PL.PAR eat-PRS.PCPL.(SG)ACC boy.ACC
 läbi.
 through
 ‘Mother scolded the boy (who was) eating all the cakes (at that moment).’

Crucially, (194) does not mean that there is a boy who is presently doing graffiti and who was detained by police (in the past), and (195) does not mean that there is a boy who is presently eating all the cakes who has (in the past) been scolded by his mother.

Similarly, “past” participles do not indicate past tense, but telicity. Some examples of past PAs are given in (196) and (197). Note that past PAs do not show concord. I will return briefly to this fact in section 3.5.1.1.

(196) [Kõik kliendi-d **kaota-nud**] firma juht jäi
 all.PL.ACC client-PL.ACC lose-PST.PCPL firm.GEN leader.NOM remain.PST.3SG
 töö-ta.
 work-ABE
 ‘The leader of the firm that lost all its clients was without work.’ (BALANCED)

(197) **söö-nud** inimes-te-le
 eat-PST.PCPL person-PL-ALL
 ‘to people who have eaten’ (Erelt 1999:19)

In (196), the past PA *kaotanud* ‘lose-PST.PCPL’ modifies the subject of a past tense sentence. This sentence cannot mean that the firm leader was without work at the time that the firm was losing all of its clients. Rather, the client loss must precede the reference time of the main verb. Despite the fact that the terms are misleading, I will continue to call them *present participles* and *past participles* in what follows.

(201) Partitive objects

- a. [lõuna-t söö-v] inimene
lunch-PAR eat-PRS.PCPL.NOM person
'a person eating lunch' (EKSS, entry for *lõunaline*)
- b. [jalatse-id paranda-v] oskustööline
shoe-PL.PAR repair-PRS.PCPL tradesman
'a tradesman who repairs shoes' (EKSS, entry for *kingsepp*)

The objects of past PAs are marked with accusative case, as in (200). The objects of present PAs are marked with partitive case, as in (201).

Setting cases of quirky case-marking aside, Estonian internal arguments typically bear one of two cases: accusative or partitive.¹⁰ The choice between accusative and partitive is affected by a number of factors, but one of them is telicity: atelic predicates generally have partitive objects and telic predicates generally have accusative objects.¹¹ This lines up with what we have seen in PAs: “present” atelic PAs have partitive objects, and “past” telic PAs have accusative objects. The most important distributional fact is that accusative is assigned in one and only one context in Estonian: the internal argument position of verbs. To be perfectly clear, accusative is not *always* assigned to the internal argument position of verbs, but there are no adpositions that assign accusative case, and there are no verbs that have quirky accusative subjects. Perhaps most importantly, there are no root adjectives that assign accusative case (or partitive, so far as I know) in Estonian. Thus, this is another verbal property of PAs.

Given these observations, it is not surprising that PAs can also contain verbal derivational suffixes, like the causative derivational suffix *-ta* (see (202)) or the anticausative derivational suffix *-u/ne* (see (203)).

- (202) a. kaela-l **kasva-v** sulg
neck-ADE grow-PRS.PCPL feather
'a feather that grows on the neck'
literally 'on-the-neck growing feather' (EKSS, entry for *kaelasulg*)

¹⁰Traditional descriptions hold that the objects that I mark as accusative are either genitive or nominative. I argue against this view in chapter 4.

¹¹This is surely a simplification. Object case-marking in Finnish and Estonian has received much attention in the literature, but it would take us too far afield to get into the issues in detail here. For discussion of the alternation in Estonian, see Tamm 2007.

- b. seesuguse-id õunu **kasva-ta-v** õunapuu
 this.kind-PL.PAR apple.PL.PAR grow-CAUS-PRS.PCPL apple.tree
 ‘an apple tree growing this kind of apple’ (EKSS, entry for *kuldrenett*)
- (203) a. **solva-v** ütlus või tegu
 insult-PRS.PCPL utterance or act
 ‘an insulting utterance or act’ (EKSS, entry for *solvang*)
- b. kergesti **solv-u-v** inimene
 easily insult-ANTICAUS-PRS.PCPL person
 ‘an easily offended person’ (EKSS, entry for *hellik*)

These affixes are no longer fully productive in Estonian (see Kehayov & Vihman 2013 and references there). I assume this means they are very closely connected to the verbal root.

To put all of this information together, I present the morphological structure of PAs in (204).

(204)	$\sqrt{\text{ROOT}}$ -	-derivation	-PASS	-PCPL	-CMPR/SUPER	-AGR
	kasva-	-ta		-v		-∅
	solv-	-u		-v		-∅
	söö-		-da	-va		-tele
	loe-		-ta	-va	-ma	-id

Note that the verbal aspects of PAs appear inside of the PA -v affix and the adjectival properties appear outside it.

3.2.3.3 Analysis: participial adjectives as adjectivized vPs

To account for the mixed adjectival and verbal properties of PAs, I propose that they are not just adjectives based on a verbal root, but fully formed vPs embedded under an adjectivizing a^0 head (see Koskinen 1999 for a similar proposal for the cognate class of words in Finnish, and Babby’s (2009) analysis of similar forms in Russian).¹² This analysis is represented in the structure in (205).

¹²I should note that Koskinen’s proposal focuses primarily on their use as nonfinite complement clauses in Finnish. PAs in Estonian are not possible in these contexts: they are only possible in adjectival positions.

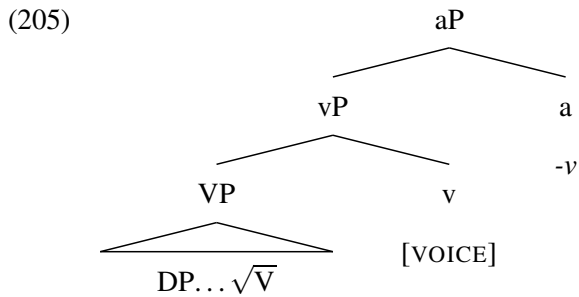

The mixed structure in (205) straightforwardly captures the mixed character of PAs. The verbal material is merged first, including voice morphology, which I assume is introduced by v^0 . This entire constituent is then adjectivized, accounting for its external distribution as an adjective.

An interesting contrast can be made between PAs and deverbal nominalizations made using the productive suffix *-mine* [mine]. Note first that, like PAs, *mine*-nominalizations can contain verbal derivational morphology.

- (206) solva-mine / solv-u-mine / kasva-mine / kasva-ta-mine
 insult-NMLZ / insult-ANTICAUS-NMLZ / grow-NMLZ / grow-CAUS-NMLZ
 ‘insulting’ / ‘umbrage’ / ‘growing (intr.)’ / ‘growing (tr.)’

However, unlike PAs, *mine*-nominalizations do not permit passive morphology— speakers reject them as ill-formed words. Thus, all the examples in (207) are ungrammatical.

- (207) * pese-ta-mine / kiide-ta-mine / lüü-a-mine
 wash-PASS-NMLZ / praise-PASS-NMLZ / hit-PASS-NMLZ

Furthermore, solitary arguments of *mine*-nominalizations, which are rendered as prenominal possessors, can be interpreted as either the internal or external argument. We can see this in (208) and (209).

- (208) poisi pese-mine
 boy.GEN wash-NMLZ
 ‘(someone’s) washing of the boy’ /
 ‘the boy’s washing (of something)’ (Erelt et al. 2000:583)

- (209) meie kiit-mine
 we.GEN praise-NMLZ
 ‘(someone’s) praising of us’ /
 ‘our praising (of someone)’ (Erelt et al. 2000:583)

In (208), either the boy is being washed, or the boy is doing the washing. Note that these examples also reveal a third difference between PAs and *mine*-nominalizations: the ability to assign object cases. As we have seen, PAs assign normal object cases to internal arguments, but this is not possible for *mine*-nominalizations.

The analysis of PAs presented here (in (205)) provides a straightforward way to account for the observed differences between PAs and *mine*-nominalizations. Both contain some amount of verbal material, but PAs contain more. Concretely, I suggest the analysis in (210) for *mine*-nominalizations.

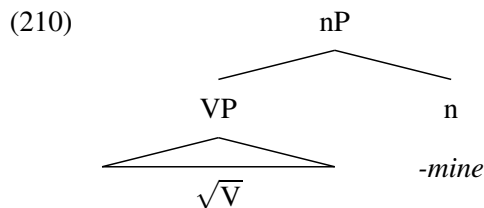

The difference between (210) and (205) is that (210) lacks the v^0 head responsible for voice and conceivably, the ability to assign object cases. This further supports the idea that PAs contain verbal structure, as we can clearly identify that they contain *more* verbal structure than other word forms based on verbal roots, like *mine*-nominalizations.

With this analysis in hand, I am now in a position to make an argument on the basis of PAs.

3.2.3.4 Participial adjectives are not syntactic probes

One of the adjectival properties of PAs is that they show concord with the noun they modify. Recall the examples in (198), repeated below.

- (198) a. söö-va-te-le inimes-te-le
 eat-PRS.PCPL-PL-ALL person-PL-ALL
 ‘to eating people’
- b. söö-da-va-te-le õun-te-le
 eat-PASS-PRS.PCPL-PL-ALL apple-PL-ALL
 ‘to apples to be eaten / to edible apples’

To be absolutely clear, the examples in (198) are ungrammatical if the PA fails to show concord in either number or case.

- (211) a. * söö-va-le inimes-te-le
 eat-PRS.PCPL-ALL person-PL-ALL

Intended: ‘to eating people’

- b. * söö-va-te inimes-te-le
eat-PRS.PCPL-PL person-PL-ALL
Intended: ‘to eating people’

If concord is predicated on an Agree relation, then that would mean the adjectivizing a^0 head is merged with unvalued ϕ -features ($[u\phi]$) (or, at least, $[uNUM]$). If this is true, then we expect the a^0 head to probe its c-command domain in search of a suitable goal.

Keeping this in mind, let me now observe that many of the examples of PAs we have seen up until this point have involved nominal objects that I have proposed are part of the AP headed by the PA. If the analysis in (205) is right, then these nominal elements must be normal DP arguments of exactly the same type as a normal verb would select. I will give two arguments that these nominal elements are normal DP objects. First, these DPs are marked with the normal Estonian object cases. We have already seen examples that show this, but they are repeated below for convenience.

(200) Accusative objects

- a. [kõik kliendi-d kao-ta-nud] firma juht
all.PL.ACC client-PL.ACC lose-CAUS-PST.PCPL firm.GEN leader.NOM
‘the leader of the firm that lost all (its) clients.’ (BALANCED)
- b. [kõige suure-ma varanduse krahma-nud] mängi-ja
all.GEN big-CMPR.ACC fortune.ACC grab-PST.PCPL play-ER.NOM
‘the player getting the largest fortune’ (BALANCED)

(201) Partitive objects

- a. [lõuna-t söö-v] inimene
lunch-PAR eat-PRS.PCPL.NOM person
‘a person eating lunch’ (EKSS, entry for *lõunaline*)
- b. [jalatse-id paranda-v] oskustööline
shoe-PL.PAR repair-PRS.PCPL tradesman
‘a tradesman who repairs shoes’ (EKSS, entry for *kingsepp*)

I will provide more discussion of object case-marking in chapter 4, but for now, it suffices to reiterate that accusative and partitive are the cases that verbs assign to their objects.

The second argument that these are normal DP objects is that they can contain all the material that normal DPs can contain. Some of the relevant examples have already been presented. The objects of PAs can include strong quantifiers as in (196) and adjectives as in (194).

- (196) [Kõik kliendi-d **kaota-nud**] firma juht jäi
 all.PL.ACC client-PL.ACC lose-PST.PCPL firm.GEN leader.NOM remain.PST.3SG
 töö-ta.
 work-ABE
 ‘The leader of the firm that lost all its clients was without work.’ (BALANCED)
- (194) Politseipatrull pida-s [kummalis-t grafiti-t **tege-va**]
 police.patrol.NOM hold-PST.3SG strange-PAR graffiti-PAR do-PRS.PCPL.ACC
 poisi kinni.
 boy.ACC closed
 ‘The police patrol detained a boy (who was) doing strange graffiti (i.e., they caught
 him in the act).’

The objects of PAs can also contain demonstratives as in (212) and numerals as in (213).

- (212) Politseipatrull pida-s kinni [seda pampu **kand-va**
 police.patrol.NOM hold-PST-3SG closed this.PAR bundle.PAR carry-PRS.PCPL.ACC
] mehe.
 man.ACC
 ‘The police patrol detained a man carrying that bundle.’
- (213) Politseipatrull pida-s kinni [kaht pampu **kand-va**]
 police.patrol.NOM hold-PST-3SG closed 2.PAR bundle.PAR carry-PRS.PCPL.ACC
 mehe.
 man.ACC
 ‘The police patrol detained a man carrying two bundles.’

Following the conclusions in chapter 2, the fact that object nominals of PAs can contain all this functional material leads me to conclude that they must be normal DPs.

With respect to this last argument, the point is that these are full DPs, not (pseudo)-incorporated submaximal nominal elements. Under such an analysis, perhaps PAs would have a structure like that in (214).

- (214) Alternative analysis: PA “objects” as incorporated N(P)s

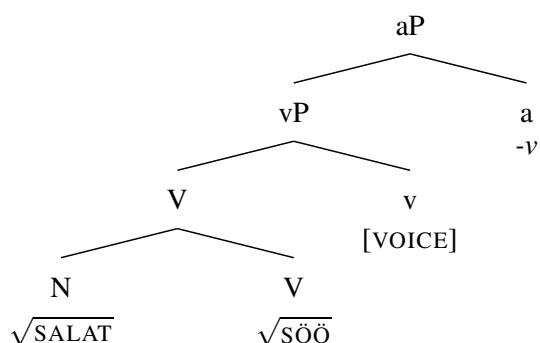

In this alternative analysis, the “object” of a PA is not a full DP. At this point, it is worth noting that there is a construction in English that looks superficially similar to the Estonian PA construction I have been discussing. Some examples are given in (215).

- (215) a. I met a salad-eating man.
 b. I saw a book-reading woman.

There are a number of ways in which these examples look superficially similar to Estonian PAs. They contain an element formed from a verbal root that appears to be in an adjectival position. They also contain a nominal element, but that nominal element is of a different nature than the one seen in Estonian PAs. Observe, for example, that the nominal element in this English construction is quite small. It cannot contain determiners or numerals.

- (216) a. * I met a the/that salad-eating man.
 b. * I saw a three bags-carrying woman.

The examples in (215a) and (216a) form a minimal pair. The addition of the determiner *the* or *that* in (216a) renders the utterance ungrammatical. (Note as well the grammaticality of *I met the salad-eating man*). Regarding the example in (216b), it seems worth noting that marking the nominal for plural is enough to make these constructions sound degraded.

- (217) a. * I met a salads-eating man.
 b. * I saw a bags-carrying woman.

We can understand the difference between the English constructions and PAs in Estonian by positing that the nominal elements in these English constructions are smaller than the arguments of Estonian PAs. Concretely, I propose that the nominals in the English constructions are NPs or simply N⁰s. In contrast, as I have argued, the nominal arguments of Estonian PAs are full DPs.

This analytical difference provides a clear path towards understanding the different modification possibilities just discussed. Taking stock, the facts we have seen so far support an analysis whereby there is verbal syntactic structure inside the phrase headed by the PA.

Returning to the main point, recall that PAs show adjectival concord. If concord is necessarily predicated on an Agree relation, then the a^0 head of PAs must be a probe (i.e., it must have $[u\phi]$). All else being equal, we expect this probe to search its c-command domain first. As I have just argued, the objects of PAs are normal DP objects, and as DPs, they must have ϕ -features. This seems like exactly the kind of structure necessary for an Agree relationship, as represented by the dashed line in (218).

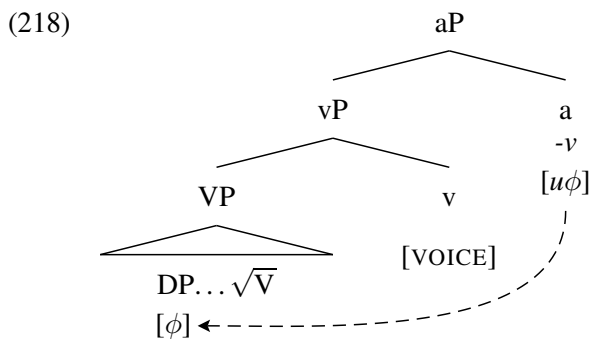

Thus, we might expect a PA in Estonian to be obligatorily plural if its argument is plural, for example. That is not what we see.

The generalization is that PAs always show concord with the noun they modify. They never show concord with anything internal to the AP. In (219) below, the embedded DP is singular, but the PA is plural like the noun it modifies. In (220), the embedded DP is plural, but the PA is singular like the noun it modifies.

- (219) Mille-ks on vaja areta-da [rohtu **söö-va-id**] lõvi-sid, ...
 what-TRL be.3 need breed-DA [grass.PAR eat-PRS.PCPL-PL.PAR] lion-PL.PAR ...
 ‘Why do we need to breed grass-eating lions (when moose already exist?)’

(BALANCED)

- (220) [kõik-i haigus-i **paranda-va-t**] imerohtu
 [all-PL.PAR sickness-PL.PAR fix-PRS.PCPL-SG.PAR] miracle.cure.PAR
 ‘a curing-all-sicknesses miracle cure’ (BALANCED)

The PAs in (219) and (220) clearly agree with the nouns they modify, and not with the internal argument of the embedded verb. More strongly, it is not possible for PAs to agree with the embedded arguments.

- (221) a. * Politseipatrull pida-s kinni kolm [pampe
 police.patrol.NOM hold-PST.3SG closed three.ACC bundle.PL.PAR
kand-va-id] mees-t
 carry-PRS.PCPL-PL.PAR man.PAR
 Intended: ‘The police patrol detained three men carrying bindles.’
- b. Politseipatrull pida-s kinni kolm [pampe
 police.patrol.NOM hold-PST.3SG closed three.ACC bundle.PL.PAR
kandva-t] mees-t.
 carry-PRS.PCPL-(SG.)PAR man.PAR
 Speaker volunteered alternative to (221a).

In (221a), the PA *kandvaid* ‘carrying’ is plural in agreement with its argument *pampe* ‘bindles’. However, the head noun is singular, and thus, this sentence is ungrammatical. In fieldwork, (221a) was corrected by changing the number of the PA so that it matched the modified noun, as in (221b). Similar corrections were suggested for (222): the only grammatical options are the ones where the number- and case-marking of the PA match the number- and case-marking of the noun they modify.

- (222) a. * Ema praga-s [kōiki kooke **söö-va-d**]
 mother scold-PST.3SG all.PL.PAR cake.PL.PAR eat-PRS.PCPL-PL.ACC
 poisi läbi.
 boy.ACC through
 Intended: ‘Mother scolded the boy eating all the cakes.’
- b. Ema pragas [kōiki kooke **söö-va**]
 mother scold-PST.3SG all.PL.PAR cake.PL.PAR eat-PRS.PCPL.(SG)ACC
 poisi läbi.
 boy.ACC through
 Speaker volunteered alternative to (222a).
- c. Ema pragas [kōiki kooke **söö-va-d**]
 mother scold-PST.3SG all.PL.PAR cake.PL.PAR eat-PRS.PCPL-PL.ACC
poisi-d läbi.
 boy-PL.ACC through
 Speaker volunteered alternative to (222a).

If adjectives were probes just like T^0 or v^0 , we might expect them to be able to agree with elements in their c-command domain. However, in all cases I am aware of, they do not agree with elements internal to the AP. In many cases, complements to A^0 heads are PPs (or could be argued to be PPs), and thus we have independent evidence for the fact that they don’t agree

with material in their complements. The evidence from PAs is, to my mind, the closest nominal configuration to what we see between T^0 and the subject DP. The data from Estonian reveal that adjectives do not show concord with material inside AP, but only with the nominal extended projection they are adjoined to.

3.2.4 Possessors and intervention

I would now like to draw our attention to another way in which concord behaves differently from subject-verb agreement. Recall that Agree requires agreement with the closest suitable goal, where *suitable* means (at least) that the goal possesses a value that the probe is looking for. Research investigating this locality requirement on Agree and the definition of *suitable* for goals has often investigated cases where the relationship between a probe and its “canonical” goal is disrupted. For example, whereas v^0 normally establishes Agree with the V^0 's internal argument, that Agree relation may be disrupted by an intervening dative argument (see, e.g., Preminger 2011).

(223) a. Normal:

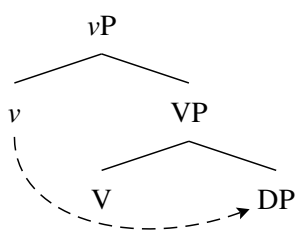

b. Intervention:

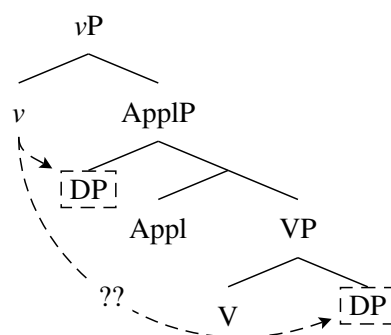

The actual empirical consequences for intervention configurations vary.

1. Agree targets the canonical target despite the closer nominal.
2. Agree targets the intervenor (closer nominal) instead of the canonical target (Deal 2013b).
3. Agree fails, resulting in default forms (Preminger 2011)
4. the entire construction is ungrammatical (see McGinnis 1998 and references there, but *cf.* Bruening Under review)

These differing empirical results could be explained by putting different constraints on Agree. For example, Preminger (2011) proposes that, upon a probe finding the intervening dative argument, the Agree operation fails (or, in Preminger’s terms, $\text{FIND}(\phi)$ aborts). However, rather than leading to a failed derivation, the probe spells out with a default value (3SG) in Preminger’s system.

Intervention configurations are arguably present in nominal concord when possessors are used. In chapter 2, I proposed that possessors occupy Spec,NumP . If we were to say that demonstratives (represented here as D^0 for simplicity) usually Agree with N^0 , possessors would be potential intervenors.

(224) a. Normal:

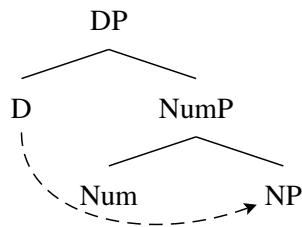

b. Intervention:

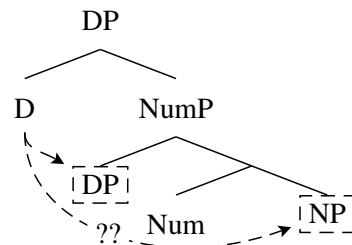

The precise predictions that are made for this instance depend, of course, on the assumptions we adopt for the fine-grained details of how Agree is established, and I will not discuss the options here. Empirically, given the options discussed above, we predict one of the following outcomes.

1. The demonstrative ignores the features of the possessor.
2. The demonstrative shows concord with the possessor instead.
3. Concord fails, resulting in default forms for the demonstrative.
4. The entire construction is ungrammatical.

In section 1, I noted that possessors in Estonian do not show concord with the possessed DP.¹³ It would not be right to say that possessors do not “show concord,” because they do, but it is concord internal to the possessor. Concord in possessors is wholly independent of concord

¹³I use the term POSSESSOR to refer to any prenominal genitive modifier, not just those that stand in a strict possession relation to the other noun.

in the modified DP. For example, if a possessor intervenes (linearly and structurally) between a higher demonstrative and a lower noun, the demonstrative still shows concord with the head noun.

(225) ... kelle kohta [see andme-te hulk] on
 ... who.GEN for [this.SG.NOM data-PL.GEN amount.SG.NOM] be.3
 kogu-tud.
 collect-PASS.PST.PCPL
 ‘... for whom this amount of data was collected.’ (PARLIAMENT)

(226) ... kes on [nee-d Riigikogu saadiku-d] ...
 who be.3 [this-PL.NOM parliament.SG.GEN ambassador-PL.NOM]
 ‘... who are these ambassadors of the parliament ...’ (PARLIAMENT)

In (225), there is a plural possessor in between a singular demonstrative and noun. In (226), there is a singular possessor in between a plural demonstrative and noun. It is not possible for the demonstrative to show concord (in number) with the possessor.

(227) a. * nee-d andme-te hulk
 this-PL.NOM data-PL.GEN amount.SG.NOM
 b. * see Riigikogu saadiku-d
 this.SG.NOM parliament.SG.GEN ambassador-PL.NOM

Instead, as the examples in (225) and (226) show, Estonian instantiates option 1: concord proceeds as normal, and the demonstrative matches the features of the possessum, not the possessor. If concord is predicated on the establishment of an Agree relation, the demonstrative must be a probe, but this probe must ignore the feature values of any intervening possessors. This strikes me as another possible empirical difference between concord and Agree—the features of “intervening” specifiers are ignored. I will not develop a formal account of this for an Agree-based account. However, I note that it would require particular assumptions about how the Agree relationship is established, which certainly seem to me to be at odds with the the assumptions required to generate the empirical results described in options 2–4.

3.2.5 Previous Approaches: Summary

In this section, I discussed some of the previous approaches to concord. To the extent that they are successful, they make an argument for a deep similarity between subject-verb agreement on the one hand and nominal concord on the other. I then focused on Agree-based accounts of

concord, and discussed some data that I believe to be puzzling under an Agree-based approach. In essence, my view is that concord simply does not look like the kind of agreement typically analyzed as being dependent on an Agree relationship. C-command between target and controller does not matter, nor does intervening specifier material. To be sure, there are ways that such facts could be incorporated into e.g., an Agree-based account,¹⁴ but, I contend, it comes at a cost: Agree must be needlessly complicated to analyze what I believe to be a fundamentally morphological phenomenon.

To make this point stronger, what I claim is that there is nothing different about the syntax of a language with concord from a language without concord: the difference is morphological. I thus share the view that morphological agreement and Agree do not track each other one to one: some instances of Agree show no signs of morphological agreement, and some instances of morphological agreement do not involve Agree (Chung 2013). I claim that concord is one example of the latter case.

Before introducing the components of the theory of concord that I propose, I would like to return to its descriptive characterization momentarily. Concord is often described as various elements “agreeing with the head noun.” This description has served as a precursor to theoretical treatments (including the Agree-based accounts), where agreement relations are indeed posited between CEs and the head noun. Of course, there is certainly no requirement that traditional descriptions be directly translated to formal analysis, though they may be clues. As it turns out, in the case of concord, the traditional description is not quite right. This will be the focus of the next section.

3.3 Refining the characterization of concord

In descriptions of concord, it is often said that CEs agree with the head noun in whatever features are relevant for concord in the language (for Estonian, number and case). In a way, this reflects

¹⁴For the PA concord facts, one could adopt Béjar & Rezac’s (2009) version of Agree with the added stipulation that the material inside of PA’s complement is inaccessible for some other reason. Perhaps evidence could be uncovered that the complement of a PA is a phase (or contains one). This would require that this phase is spelled out before the PA head is merged.

For the intervention of possessors, one could assume that whatever functional head hosts possessors must independently establish Agree with the head noun. Then, it would be conceivable that that number value would be at least as close to the probe as the number value of the possessor.

the aspect of concord that appears global— CEs in Estonian all inflect for the same set of features (i.e., case and number). In cases of what I call SIMPLE CONCORD, every CE bears the same feature values. When this is combined with the fact that nearly every element in a DP shows concord, concord looks like a very global process. For example, in (178), every element bears the feature-value pairs [NUM:PL] and [CASE:INE]. In (179), every element bears [NUM:SG] and [CASE:NOM].

(178) kõiigi-s nei-s raske-te-s küsimus-te-s
 all.PL-INE this.PL-INE hard-PL-INE question-PL-INE
 ‘in all these hard questions’ (BALANCED)

(179) kõik see ilus maailm
 all.NOM this.NOM beautiful.NOM world.NOM
 ‘all this beautiful world’ (BALANCED)

Given that the head noun also bears these features and could be argued to be the source of these features, treating concord as “agreement with the noun” seems like the simplest analysis. It may also provide an explanation for the apparent globality evident in cases of simple concord: since everything agrees with the same head, it is no surprise that everything bears the same features. This is exactly the kind of account that I proposed in Norris 2012 for Icelandic. I will now take a moment to discuss that proposal.

3.3.1 Norris 2012 on Icelandic concord: Feature Collection and Copying

In Icelandic (and Estonian) concord, it seems as though the concord features act as a bundle: if an element shows concord, then it shows concord for the same set of features as every other element showing concord. This is noteworthy given the hypothesis that features of gender, number, and case do not all come from the same place. In particular, a common proposal regarding gender and number is that they originate on heads near the bottom of the nominal extended projection (on gender, see Carstens 1991, 2011, Kramer 2009, Ritter 1993; on number, see Kramer 2009, 2012, Ritter 1991, 1992). However, there seems to be a consensus that case feature values come from outside the nominal projection and then percolate down the tree (Babby 1987, Chomsky 1981, 1986, Delsing 1993, Matushansky 2008, Pesetsky 2013, Richards 2012). This is represented in the structure in (228).

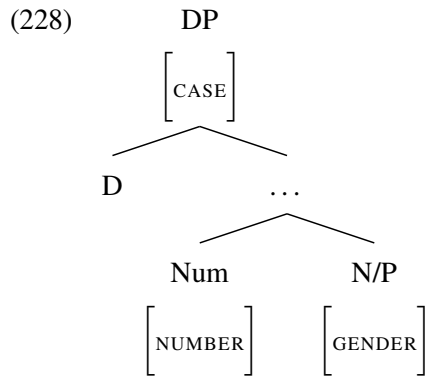

Despite these different sources, the elements showing concord in Icelandic end up bearing all three feature values, as we can see in (229).

- (229) af öll-um hin-um litl-u snigl-u-n-um mín-um fjór-um
 of all-CM other-CM little-CM.WK snail-DAT.M.PL-the-CM my-CM four-CM
 ‘of all my other four little snails’

In (229), every CE bears a concord marker (glossed CM) indicating the same set of features: [DATIVE], [MASCULINE], and [PLURAL].

In an analysis of Icelandic concord (Norris 2012), I proposed that the highest head in the nominal extended projection is a K^0 head with uninterpretable/unvalued gender and number features (on KP, see Lamontagne & Travis 1987, Bittner & Hale 1996 among others). When K^0 is merged, it searches its c-command domain to find values for number and gender. It finds those values on Num^0 and N^0 , respectively. Then, when KP gets a value for case, K^0 will possess values for all three features, as schematized in the structure in (230) below.

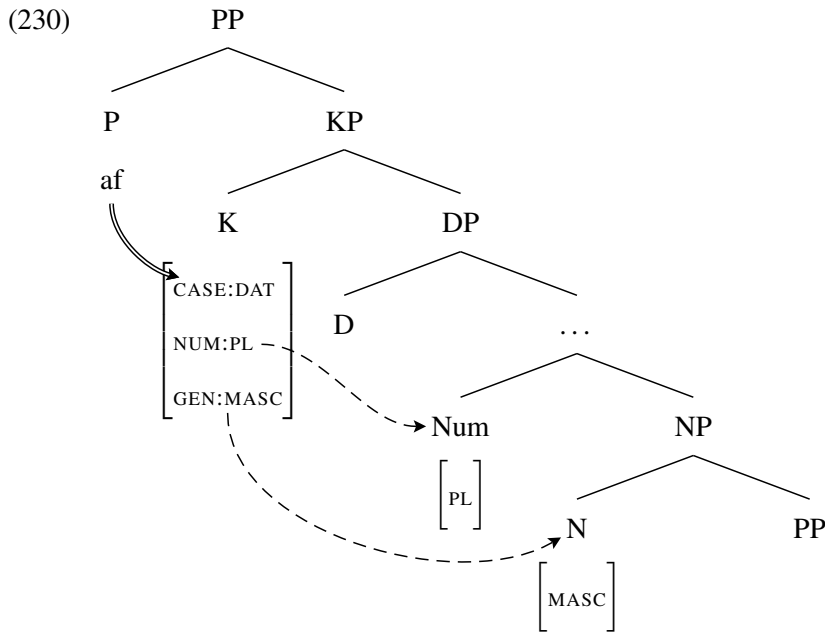

I called this sequence of events FEATURE COLLECTION, though the term is meant purely descriptively. *Modulo* other syntactic processes, this is the structure that is built in the syntax and sent to the interfaces.

At PF, I adopted a view of agreement from work within Distributed Morphology (Noyer 1997, Kramer 2010). The various heads showing concord trigger insertion of Agr⁰ (for “agreement”) nodes, as represented by the schematic below:

(231) **Agr node Insertion schema**

$$X \rightarrow [X \text{ Agr}]$$

After Agr⁰ nodes are inserted, the values from K⁰ are copied onto the Agr⁰ nodes via a rule of Feature Copying, as written below:¹⁵

(232) **Feature Copying**

The features of the closest c-commanding K⁰ to any particular Agr node are copied onto it.

This rule of Feature Copying is schematized in the tree in (233) below. For reasons of space, I represent the features as being on the CEs themselves, though the proposal in Norris 2012 is

¹⁵To my knowledge, the nature of Feature Copying (e.g., its restrictions and conditions for application) has not been thoroughly investigated. In Kramer 2009, 2010, it is simply stated as a prose rule, much like what is given here. I will propose a formal version of Feature Copying for concord in section 3.5.2.

that the features are on Agr⁰ nodes adjoined to the CEs.

(233)

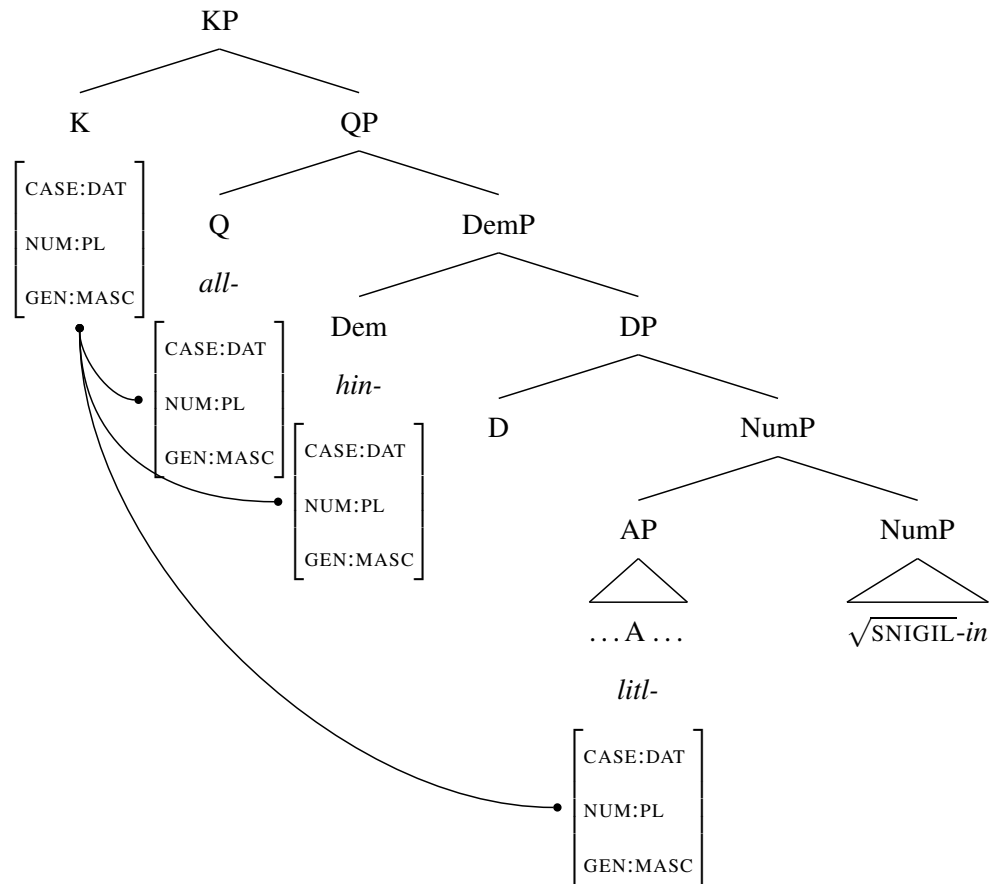

By doing the feature distribution in the morphology, Norris could capture the intuition that concord is not sensitive to syntactic relationships in the same way as subject-verb agreement. Because the heads do not acquire their features through syntactic operations alone, we do not expect their syntactic position to matter as much as it apparently does for subject-verb agreement. Thus, for example, the fact that adjectives regularly show concord yet are not in a position to c-command the noun is no longer problematic. Thus, every CE in the Icelandic DP in (229) bears gender, number, and case, because every CE gets its features from a K⁰ head bearing those features. This analysis rejects the idea that descriptive characterization “agreeing with the head noun” directly reflects the optimal theoretical analysis. CEs do not agree directly with the head noun, though they do end up bearing the same features as the head noun.

Furthermore, this analysis provides an understanding for why the features in concord appear to behave as a unit: they are all copied from the same source, namely K⁰. This is a welcome

result. However, this analysis makes an even stronger prediction. Not only do we expect every CE to inflect for the same features, we expect every CE to bear the same feature *values* as well. In (233), it is not just features that are copied, but feature-value pairs: [CASE:DAT], [NUM:PL], and [GEN:MASC]. Indeed, there are many DPs where this is true, e.g., (229)— these are the cases of simple concord. As it turns out, though, this prediction is too strong, as there are also DPs where it is not the case that every CE bears the same feature-value pairs. I call these situations COMPLEX CONCORD, and I will now turn to a discussion of a clear example in Estonian.

3.3.2 Complex concord in Numeral-Noun Constructions in Estonian

Complex concord is exemplified by Estonian numeral-noun constructions. I discussed their syntactic structure in some detail in chapter 2, but let us review the morphological generalizations. First, the material to the right of the numeral must be marked partitive and singular.

- (234) a. kaks inimes-t / *inimese-d / *inimesi
 two.SG.NOM person-SG.PAR / person-PL.NOM / person.PL.PAR
 ‘two people’
- b. viis toonekurge / *toonekure-d / *toonekurgi
 five.SG.NOM stork.SG.PAR / stork-PL.NOM / stork-PL.PAR
 ‘five storks’

The noun cannot be marked with plural, regardless of its case-marking. On the subject of case-marking, let me once again note that partitive case-marking on the numeral’s complement only surfaces in the context of nominative and accusative case. For all other cases, the numeral and its complement must match in case. This is shown in (235) for adessive case and inessive case.

- (235) a. kahe-l koosoleku-l
 two-ADE meeting-ADE
 ‘in two meetings’ (PARLIAMENT)
- b. viie-s viimase-s matši-s
 5-INE final-INE match-INE
 ‘in the final five matches’ (BALANCED)

The alternation between the kind of case-marking seen in (234) and (235) will be the focus of chapter 4. For now, I will focus on the examples with partitive case.

Next, recall that CEs to the left of numerals must be plural (Erelt et al. 1993b, 2000). For example, a demonstrative used with a numeral-noun construction must be plural, as in (236).

- (236) a. nee-d viis inimes-t
 this-PL.NOM 5.NOM person-PAR
 ‘these five people’
- b. * see viis inimes-t
 this.SG.NOM 5.NOM person-PAR
 Intended: ‘these five people’

This is particularly clear with adjectives, which can occupy a position either above or below the numeral. The position of the adjective affects its case-marking *and* its number-marking. When the numeral occupies a low position, it is partitive and singular, as in (237a). When it occupies a high position, it is nominative and plural, as in (237b).

- (237) a. nee-d viis ilusa-t maja
 this-PL.NOM 5.NOM beautiful-PAR house-PAR
 ‘these five beautiful houses’ (Erelt et al. 1993b, 143)
- b. nee-d ilusa-d viis maja
 this.PL.NOM beautiful-PL.NOM 5.NOM house.PAR
 ‘these five beautiful houses’¹⁶ (Erelt et al. 1993b, 143)

See Brattico (2010, 2011) for identical facts in Finnish.

As for the numeral itself, it is traditionally described as bearing nominative case and singular number. I would like to take a moment to show that this must be true. In traditional grammars, partitive forms of numerals are given, and these partitive forms are always distinct from the nominative/accusative form. The numerals for 2–10 are shown in Table 3.3. One context where partitive case forms of numerals are regularly used is in negative sentences. Objects under negation can only be marked with partitive, whereas objects can normally show either partitive or accusative case.¹⁷ If we put a numeral-noun construction in object position of a negated declarative, we see clearly that the partitive form of the numeral is used.

¹⁶This order is certainly the marked order, but I do not yet know what the meaning difference is. I was told it was connected with restrictivity, but I have not been able to find that claim in the literature. For example, it is not discussed in Erelt’s (1986) book on the syntax of adjectives. It is the subject of ongoing investigation.

¹⁷A notable exception is in the case of correction: e.g., *Juku ei suusatanud ühe kilomeetri, vaid kolm kilomeetrit.* ‘Juku didn’t ski one.ACC kilometer.ACC, but three.ACC kilometers.PAR.’

NOM	GEN	PAR	GLOSS
kaks	kahe	kaht(e)	'two'
kolm	kolme	kolme	'three'
neli	nelja	nelja	'four'
viis	viie	viit	'five'
kuus	kuue	kuut	'six'
seitse	seitsme	seitsmet	'seven'
kaheksa	kaheksa	kaheksat	'eight'
üheksa	üheksa	üheksat	'nine'
kümme	kümne	kümnet	'ten'

Table 3.3: Partial case paradigms for ordinal numerals in Estonian

- (238) Heiko ei näi-nud neid viit maja.
H.NOM NEG see-PST.PCPL this.PL.PAR five.PAR house.PAR
'Heiko didn't see these five houses.'
- (239) Heiko ei söö-nud kaht võileiba.
H.NOM NEG eat-PST.PCPL two.PAR sandwich.PAR
'Heiko didn't eat two sandwiches.'

We can also see that the numeral is not plural. Numerals do, in fact, have plural forms, and those plural forms have the same morphological structure as normal nominal elements in the language (i.e., they are built in the same way): for example, the nominative plural is formed by taking the genitive singular form and adding *-d*. As I discussed in chapter 2, these plural numerals are used with *pluralia tantum* nouns, which I assume include nouns that denote pairs/sets of things (e.g., mittens, shoes, pants, so on). A minimal pair is given in (240):

- (240) Nemvalts 1996:47-49:
- a. Mu-l on kolme-d malendi-d.
I-ADE be.3 three-PL.NOM chessman-PL.NOM
'I have three chess sets.'
- b. Mu-l on kolm malendi-t.
I-ADE be.3 three.SG.NOM chessman-SG.PAR
'I have three (random) chess pieces (i.e., a pawn, a queen, and a king).'

Whereas the singular numeral in (240a) indicates that the speaker has three full chess sets, the plural numeral in (240b) simply means that the speaker has three random chess pieces. Thus, the numeral in a typical numeral-noun construction is clearly nominative and singular. We saw in (238) and (239) that it is not partitive, and we can see in (240a) and (240b) that it is not plural.

The material in the complement of the numeral is singular and partitive. The material above the numeral is nominative and plural. The numeral itself occupies a middle ground between the two groups. It is nominative like the material above it, and it is singular like the material below it. This is diagrammed in Figure 3.1. The boxes around the categories indicate the domains of

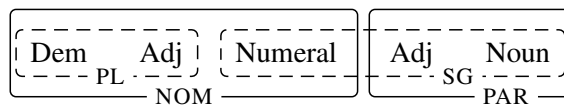

Figure 3.1: Overlapping feature domains in Estonian concord

feature expression. The numeral is the only element inside the nominative box and the singular box; it is the only element that is nominative and singular.

3.3.3 Summary: Locality in numeral-noun construction concord

The traditional description of concord as “agreement with the head noun” suggests that CEs will bear the features that the head noun bears. In examples of simple concord, this description suffices and leads us to say that elements such as demonstratives show concord, as they bear the same feature values as the head noun. In numeral-noun constructions, this is no longer transparently true. Demonstratives are nominative and plural, but the head noun is singular and partitive. Complex concord suggests that either (i) demonstratives cannot be described as “showing concord” or (ii) the traditional description of concord as “agreement with the head noun” needs to be revised.

Briefly, what I propose instead is that concord is a morphological requirement of a given language. In a language like Estonian, certain words must express number and case to be fully-formed words. The particular values they express are dependent on the DPs they are a part of. In simple concord, only one value is available, so every element ends up bearing the same set of feature values. Complex concord reveals that there is a degree of locality in concord. In Norris 2012, I argued that CEs get their features from a (potentially) non-local source—the top of DP. In that analysis, there was a single head responsible for driving concord, and there were virtually no locality requirements.

What Estonian numeral-noun constructions suggest is that, in a sense, CEs get their feature values from the closest possible source. What’s more, the domains for case on the one hand and number on the other are not isomorphic. In other words, there are multiple drivers of

concord, and there is an amount of locality with empirical consequences for each. In the next section, I will propose that “closest” is determined on the basis of domination (or more properly, inclusion) rather than c-command. When there is only one value available for each feature, we get the cases of simple concord that appear global, because every CE expresses the same features and the same feature values. However, if there is more than one value available, we see the emergence of more local domains in concord. Concord is not a relationship between CEs and the head noun, but a relation of membership: CEs express certain features of the phrases that include them.

In the next two sections, I will propose a formalization of this conceptualization of concord. It will be broken up into two parts. In section 3.4, I will propose explicit mechanisms of feature spreading (or sharing) that will define the different domains for the features involved in concord. I will propose that these are universal and take place in the syntax. Whether or not a language actually has nominal concord does not come into play until the morphological component, and in section 3.5, I propose an analysis of concord that involves copying feature values from local sources as defined by the syntactic mechanisms of feature spreading. This is the part of the analysis where (more) language-specific considerations come into play.

3.4 The syntactic side of concord

In this section and the next, I will propose a theory of nominal concord that accounts for the patterns seen thus far. Based on what we have seen so far, I believe there are two aspects of concord that a theory of concord must allow for.

1. A theory of concord must allow for the existence of locality effects (in the domain of feature expression).
2. A theory of concord must allow for the fact that a CE does not need to c-command the putative source of the features it expresses.

I pursue an analysis that derives these facts from the hypothesis that concord is primarily morphological. By that, I mean that there is nothing different about the *syntax* of a language with concord from the *syntax* a language without concord. This theory is developed on the basis of data from Estonian, though I will consider some typological implications in section 3.5.

This section focuses on setting up the domains that are relevant for the locality effects. Although the features involved in concord are introduced in different positions in the nominal extended projection, I will propose that they spread from those positions throughout the DP such that they are accessible to the various CEs in DP. Note, however, that ϕ -features and case features are arguably not introduced in the same positions: ϕ -features are generally believed to originate low in the DP spine, and case is generally believed to be a property of DPs, originating high. What this means for Estonian is that number and case features will spread in different ways, which will open up the possibility that their domains of spreading are also defined differently.

Before outlining my proposal, I would like to take a moment to discuss an argument for feature spreading independent of the existence of concord.

3.4.1 A theoretical argument for feature spreading

In much research investigating agreement, ϕ -features (and case features) are treated as features of DPs. This assumption is seemingly at odds with the conclusions about ϕ -features emerging from research investigating the internal syntax of nominals. Concretely, it has been proposed that these features originate in different places in the nominal spine. For example, Ritter (1991) (among others) argues that number features are introduced by Num(ber)⁰, and Kramer (2009) (among others) argues that gender features are introduced by N⁰/n⁰. This discrepancy was the focus of a recent article by Danon (2011). His concern is this: how do ϕ -features get from their points of origin to the top node of the nominal projection where they can be accessible to external operations (e.g., Agree)?

(241) Danon's puzzle: v^0 looks for ϕ -features on DP, but ϕ -features originate elsewhere.

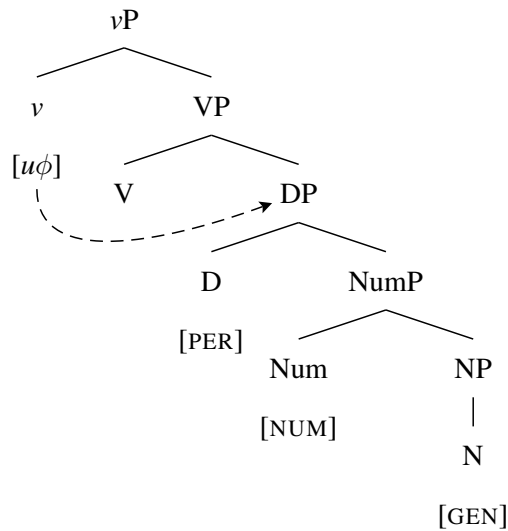

Danon proposes that the features come to be instantiated on the DP node by way of Agree (more specifically, the feature-sharing version of Agree advocated by Frampton & Gutmann (2006), Pesetsky & Torrego (2007) among others). Thus, Num⁰ establishes Agree with N⁰, resulting in both heads sharing the features [NUM] and [GEN]. Then, D⁰ establishes Agree with Num⁰, resulting in all three heads having the features [NUM], [GEN], and [PER]. This also means that external probes can access all three features on D⁰.

To support this proposal, Danon observes that D⁰ shows concord in some languages, suggesting that an Agree relation between D⁰ and lower elements is independently necessary. This account of determiner concord raises the same questions I addressed in Section 3.2, because concord does not fit neatly into an Agree-based analysis. It has difficulty extending to adjectival concord, as adjectives are not in the proper structural position to serve as probes,¹⁸ and (ii) specifier material does not seem to block an Agree relationship between a c-commanding probe and a goal that the specifier c-commands, though Danon does not discuss this issue. Though we disagree about how it is resolved, I agree with Danon that a complete theory of ϕ -features within DPs needs to have an explanation of how the ϕ -features instantiated on the various heads come to be accessible to external probes.

¹⁸Danon appears to assume that phrasal nodes can act as probes based on the tree he provides on page 304, but this proposal is not explicitly discussed, and its specifics remain vague.

3.4.2 ϕ -features spread from bottom to top

Though ϕ -features are introduced on various heads throughout the nominal extended projection, conceptually, they are features associated not just with the heads that introduce them, but with the entire nominal extended projection (see also Anderson (1992:109–111)). Thus, while a plural number feature [(NUM:)*PL*] is introduced on a Num⁰ head above NP, the intuition behind ϕ -feature spreading is that it is not just Num⁰ that is plural. Rather, there is a sense in which the entire DP is plural as well. More formally, I propose that features of heads (in the nominal spine) spread or percolate per the following principles.

(242) Feature Percolation Principles:

a. All projections of a head X⁰ have the feature-value pairs that X⁰ has.

b. Let [F:val] be a valued feature on XP.

Let Z⁰ be a head lacking the feature [F].

Let X⁰ and Z⁰ be members of the same extended projection (i.e., both [+N]).

When Z⁰ merges with XP, projecting ZP, ZP also has the valued feature [F:val].

The Feature Percolation Principles govern percolation in three instances.

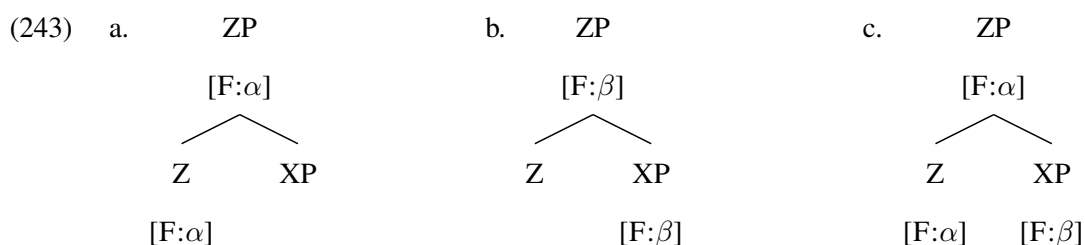

In (243a), the head Z⁰ is marked with the feature [F:α], but XP is completely unmarked. Here, only (242a) applies, and ZP thus also bears [F:α]. I take this to be uncontroversial. In (243b), XP is now marked with the feature [F:β], but the head Z⁰ is unmarked for [F]. This is where we see the effects of (242b)— because Z⁰ does not have the feature [F], ZP is marked with XP's [F:β]. This is perhaps more controversial, but it is not without precedent. I will return to it momentarily. Finally, when both the projecting head Z⁰ and the complement XP have values for the same feature [F], the new phrase is marked with the projecting head's feature value. This is regulated by (243a), and it is illustrated in (243c).

Crucially, the Feature Percolation Principles do not provide a way for features to percolate from specifiers. In such a situation, it is the feature-value pairs of the projecting head that are marked on the new phrase. To take a concrete example from Estonian, consider the situation when a possessor marked for number is merged in the specifier of NumP, as in (244).

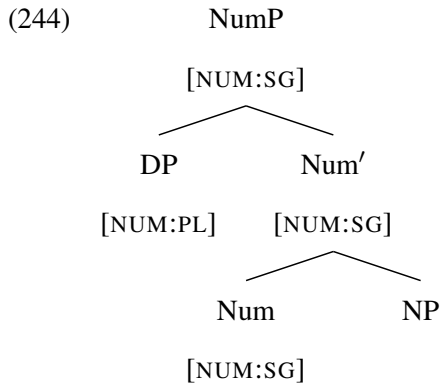

This is again predicted by the proposal that the feature-value pairs of the projecting head always take precedence. As we have seen, the number features of specifiers (i.e., possessors) do not interfere with concord in Estonian. It seems to generally be true of concord that feature values of specifiers are ignored.¹⁹

Let us return to a discussion of the principles themselves. The first principle (242a) follows directly from adopting a version of Bare Phrase Structure if we take features to be properties of a label. If minimal and maximal projections of Z^0 are taken to have the same label, then it follows automatically that all feature-value pairs that Z^0 has will be shared by all of its projections, and thus (242a) comes for free. For this reason, I assume Bare Phrase Structure here, although I continue to use bar-level labels (e.g., X' , XP) to aid in readability. I will still reference the Feature Percolation Principles (plural), though, because I believe it is important to keep both aspects of percolation (i.e., (242a) and (242b)) in mind.

The second principle (242b) has much precedent in the early morphological literature (see Selkirk's (1982) *Percolation* or Lieber's (1989) *Back-Up Percolation Principle*) as well as foundational work in GPSG (see the Control Agreement Principle (Gazdar, Klein, Pullum & Sag 1985:83–94)).

¹⁹This means, of course, that the kind of percolation I am talking about here must be different from the percolation of [WH] features argued to be at work in pied-piping (see Heck 2004 and references there). Those cases *do* allow wh-features to percolate out of specifiers (in part to generate pied-piping of constructions like *whose book*). See also Cable 2007, Coon 2009 for arguments that pied-piping does not involve percolation.

(245) Percolation (Selkirk 1982:76):

- a. If a head has a feature specification $[\alpha F_i]$, $\alpha \neq u$ [nspecified], its mother node must be specified for $[\alpha F_i]$, and vice versa.
- b. If a nonhead has a feature specification $[\beta F_j]$, and the head has the feature specification $[u F_j]$, then the mother node must have the feature specification $[u F_j]$.

(246) Back Up Percolation (Lieber 1989:99):

if the node dominating the head remains unmarked for a given feature after Head Percolation, then a value for that feature is percolated from the closest nonhead branch marked for that feature. Back Up Percolation propagates only *values* for unmarked features.

These proposals were made in light of situations where there is evidence that a particular node is the head of a word (e.g., that N^0 is the head because the word acts like a noun), but that features of some non-head element are relevant for a that head word (or come to be marked on it). It is in those instances that the non-head features percolate to the dominating node. Though these were developed in investigations of words, I apply the same principles to percolation in phrasal syntax.²⁰

Note as well that this proposal fits with the view that the same syntactic processes operative in building phrases are at work in the construction of words. This is one of the core hypotheses motivating research within the framework of Distributed Morphology.

There are also empirical domains suggesting that, when two feature values come into conflict, further agreement can only reference the higher value. While I will not provide detailed analyses of these phenomena, I will sketch how the patterns we see are exactly what my analysis would predict.

Semantic vs. syntactic feature conflict

The first domain I will discuss is what I will call *semantic vs. syntactic feature conflict*. As we know, features like number and gender lead a double life. On the one hand, they have a connection to semantics. Some gender systems are based entirely on semantics, but even

²⁰See Coppock & Wechsler 2012 for another proposal that makes use of the same feature percolation (for definiteness features) in the syntax.

those that have a looser connection with semantics (so-called “grammatical gender”) still have a semantic core (see, e.g., Corbett 1991:63). The same could be said of number— while it may be the case that not all uses of the plural are semantically transparent (especially pretheoretically), some certainly are. Yet these features also have morphosyntactic instantiations that need not reflect the semantic reality.

To take one such example, there are some nouns in Russian that have masculine grammatical gender, even if they refer to female individuals, e.g., *vrač* ‘doctor’, *professor* ‘professor’, *aktër* ‘actor’, and many others (see Pesetsky 2013 and references there). However, in the case that they do have a female referent, feminine agreement is possible:²¹

- (247) a. Nov-yj vrač-ō prišël-ō.
 new-M.NOM.SG doctor-NOM.SG arrived-M.SG
 (no translation given) (Pesetsky 2013)
- b. Nov-aja vrač-ō prišl-a.
 new-F.NOM.SG doctor-NOM.SG arrived-F.SG
 (no translation given) (Pesetsky 2013)

Thus, in (247a), the adjective and verb are masculine, in agreement with the (grammatical) gender of *vrač*. In (247b), the adjective and verb are feminine, in agreement with the (semantic) gender value of the referent of *vrač*. The crucial cases are the mismatches, where only one from among the adjective and verb is feminine.

- (248) a. Nov-yj vrač-ō prišl-a.
 new-M.NOM.SG doctor-NOM.SG arrived-F.SG
 (no translation given) (Pesetsky 2013)
- b. * Nov-aja vrač-ō prišël-ō.
 new-F.NOM.SG doctor-NOM.SG arrived-M.SG
 (no translation given) (Pesetsky 2013)

The pattern where the verb is feminine but the adjective is masculine (248a) is grammatical. The opposite pattern, where the adjective is feminine but the verb is masculine (248b), is not. This suggests that, once the switch to natural gender (i.e., feminine) is made, the masculine gender feature is no longer accessible.

There is another nearly identical pattern in Lebanese Arabic discussed by Pesetsky but first observed by Ouwayda (2013). Following cardinals ‘three’ through ‘ten’, nouns in Lebanese

²¹Pesetsky uses *ō* to represent a *yer*, a vowel which is not always phonologically realized. He adds the suffix to stress that he assumes it is still morphosyntactically present.

Arabic are marked plural, and so are verbs agreeing with that DP. This can be seen in (249) below.

- (249) tlat wleed / *walad daras*(-u).
 three child.PL / child-∅ studied-PL
 ‘Three children studied.’ (Ouwayda 2013)

Nouns following cardinals larger than ‘ten’, as well as the quantifier *kam* ‘how many / small amount’, are never marked for plural, but verbs agreeing with them can be either plural or unmarked. This can be seen in (250).

- (250) tleetiin walad / *wleed daras(-u).
 thirty child-∅ / child-PL studied-PL
 ‘Thirty children studied.’ (Ouwayda 2013)

The generalization emerging from these data is that if a nominal is marked for plural, then the verb must be marked for plural as well.

I contend that what we have in the case of (250) is another situation where the grammatical value for a feature (number) conflicts with the the meaning of the nominal that is marked.²² Adjectives modifying these nominals can also be plural or singular, but just as before, *a plural adjective entails a plural verb* (see (251b)), but not vice versa. A plural-marked verb does not require a plural-marked adjective (see (251a)).

- (251) a. tleetiin walad mnazzam daras(-u)
 thirty child organized-∅ studied-PL
 ‘Thirty organized children studied.’ (Ouwayda 2013)
- b. tleetiin walad mnazzam-iin daras*(-u)
 thirty child organized-PL studied-PL
 ‘Thirty organized children studied.’ (Ouwayda 2013)

As discussed by Pesetsky, the patterns here are identical: semantic agreement with a structurally lower element entails semantic agreement with the higher element.

The analyses proposed by Pesetsky (2013) and Ouwayda (2013) are essentially the same as the analysis I propose here: a head bearing the marked feature value (i.e., feminine in Russian, plural in Lebanese Arabic) is merged in some location in the DP, preventing further agreement

²²In fact, Ouwayda shows that, in absence of plural-marking, a predicate of pluralities is not formed, and thus collective readings of the DPs are unavailable.

with the (unmarked) grammatical feature. For Pesetsky, this is a feminizing morpheme represented by \mathfrak{K} . For Ouwayda, it is a plural marker #.

(252) Merge sites for \mathfrak{K} (slightly abbreviated, Pesetsky 2013:40):

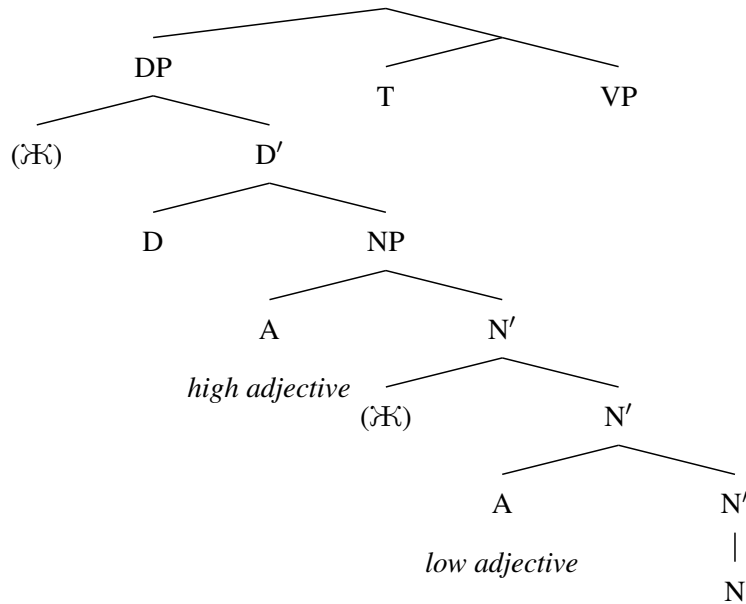

(253) The location of # in Lebanese Arabic (Ouwayda 2013):

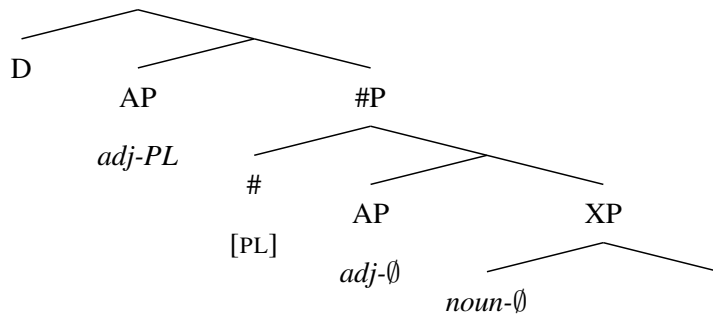

In order to generate these results under my theory of concord, all that is necessary is that \mathfrak{K} and # are heads, or at least, that the elements bearing the marked feature values are heads. In the absence of these heads, the default value (masculine for these Russian nouns and singular for the Lebanese Arabic cases) would be spread throughout the DP. When these heads are present, the Feature Percolation Principles predict that the new value (feminine for these Russian nouns and plural for Lebanese Arabic) will be marked on the new constituent instead.

Pseudopartitives

Another domain where we can see higher feature values taking over for lower values is in pseudopartitives. Pseudopartitives are constructions involving two nominal elements, with one often serving as a way of measuring the other. Some examples from Danish are given below.

- (254) a. en gruppe turister
a.CG group.CG tourists
'a group of tourists' (Hankamer & Mikkelsen 2008)
- b. et antal boliger
a.NEUT number.NEUT homes.CG
'a number of homes' (Hankamer & Mikkelsen 2008)
- c. en smule varm-t vand
a.CG little.bit.CG warm-NEUT water.NEUT
'a little bit of warm water' (Line Mikkelsen, pc)

The term “pseudopartitive” refers to the fact that, in many languages, these constructions are built in similar ways to partitive constructions like *two of the boys* or *some of the milk*. Unlike partitives, the denotation of the pseudopartitive is not really a subset of the denotation of the N2 phrase. Rather, N1 often serves as a unit of measurement, and the N2 phrase denotes the thing that is being measured.

Despite the fact that there are two words that look like nouns in pseudopartitives, it has been argued that they are not simply nouns with DP complements. For example, Hankamer & Mikkelsen (2008) propose that the only true noun in the Danish constructions is N2. They propose that N1 is of the category n^0 , which takes an NP complement headed by N2 as in the structure in (255).

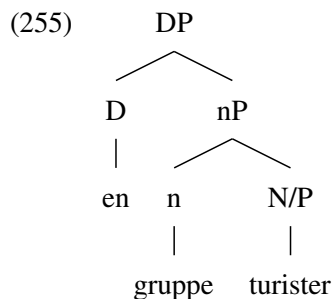

Hankamer and Mikkelsen provide a number of arguments for the functional status of $N1/n^0$: (i) it is destressed, (ii) there is a finite number of words that can be used as N1s, and (iii)

some N1s cannot bear plural-marking. I find the arguments compelling, and I henceforth adopt their analysis for pseudopartitives in Danish.

However, while N1s may have lost some features of their lexical N⁰ counterparts, they still have gender features. Unsurprisingly, when higher elements (e.g., D⁰) are merged with a pseudopartitive, they inflect for the features of N1, not N2. We saw this in, e.g., (254b) and (254c). The structure of (254c) with feature percolation is shown in (256) below.

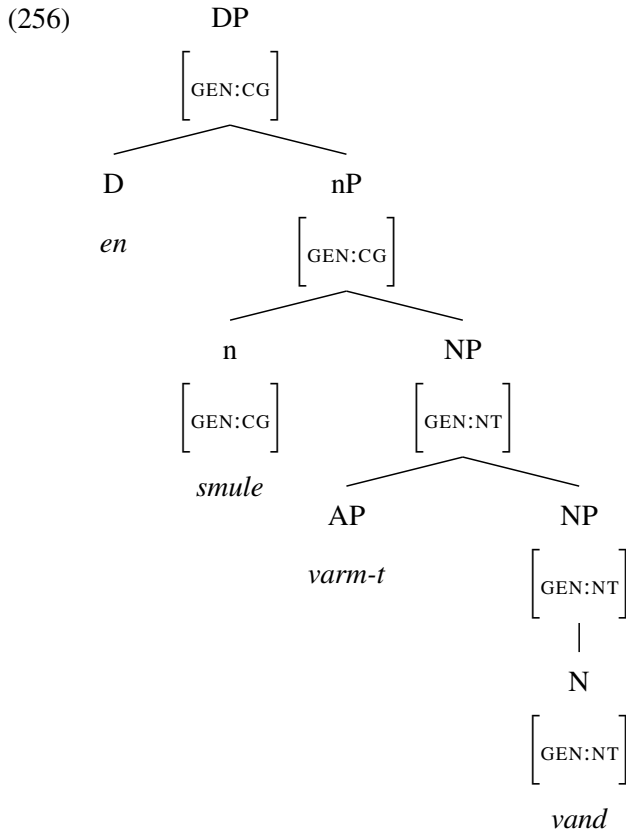

The D⁰ head of the entire pseudopartitive construction takes the form of *en*, reflecting common gender (in agreement with the n⁰ head *smule* ‘little bit’). Note, though, that the neuter gender feature of N⁰ *vand* ‘water’ is not ignored— it is marked on the adjective *varm-t* ‘warm’.

Similar facts have been described for pseudopartitives in French (Battye 1991), Greek (Stavrou 2003), Catalan (Martí Girbau 2010), and Dutch and German (van Riemsdijk 1998). Insofar as the pseudopartitive structures in those languages can be argued to constitute a single nominal extended projection (as argued by Hankamer & Mikkelsen (2008) for Danish), they constitute another domain where the feature value of the higher head percolates instead of the

- c. * nee-d ilusa-t / ilusa-id viis maja
 this.PL.NOM beautiful-PAR / beautiful-PL.PAR five.NOM house.PAR
- d. * nee-d viis ilus / ilusa-d maja
 this.PL.NOM five.NOM beautiful-NOM / beautiful-PL.NOM house.PAR
- (258) a. (viimase-d) kolm (*viimase-d) lehekülge
 last-PL.NOM three last-PL.NOM page.PAR
 ‘the last three pages’
- b. (*viimas-t) kolm (viimas-t) lehekülge
 last-PAR three last-PAR page.PAR
 ‘the three last pages’

In each of the examples above, material to the left of the numeral is plural, and material to the right is singular. Recall that the numeral itself is singular. In chapter 2, I proposed an analysis of numeral-noun constructions whereby each number feature is introduced in a different head, with the numeral sandwiched in the middle. This is represented in the structure below, repeated from chapter 2.

- (171) kõik nee-d viis inimes-t
 all.PL.NOM these-PL.NOM 5.NOM person-PAR
 ‘all these 5 people’

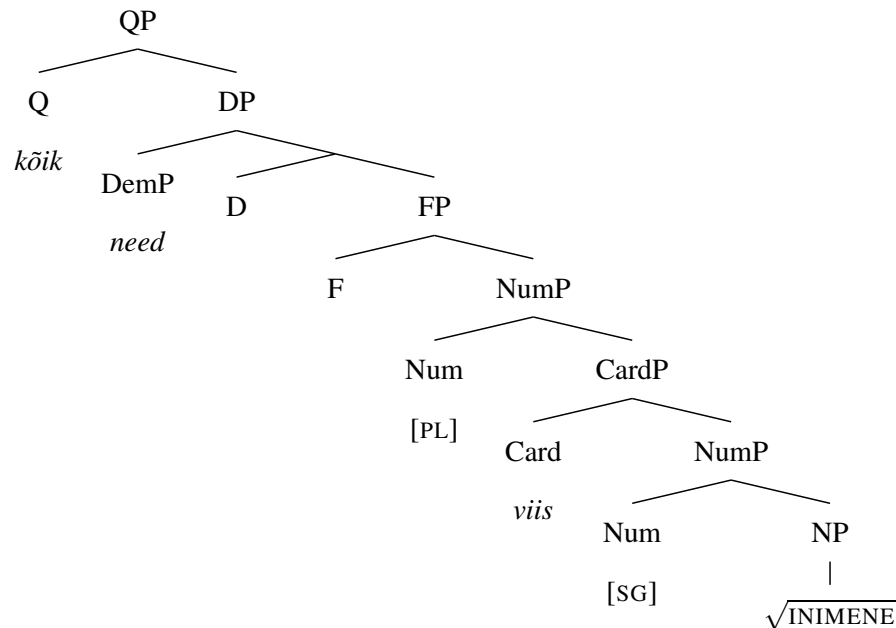

Given this structure, the Feature Percolation Principles predict the distribution of singular-marking and plural-marking within Estonian numeral-noun constructions. The singular feature

from the lower Num⁰ head will project as far as CardP. However, at that point, the plural feature of the new Num⁰ head will take over, and anything merged after that point will only have access to plural. This divides the numeral-noun construction into two domains with respect to number-marking, as indicated by the dashed arc in (259).

- (259) nee-d viis ilusa-t maja
 this-PL.NOM five beautiful-PAR house.PAR
 ‘these five beautiful houses’
(Erelt et al. 1993b:143)

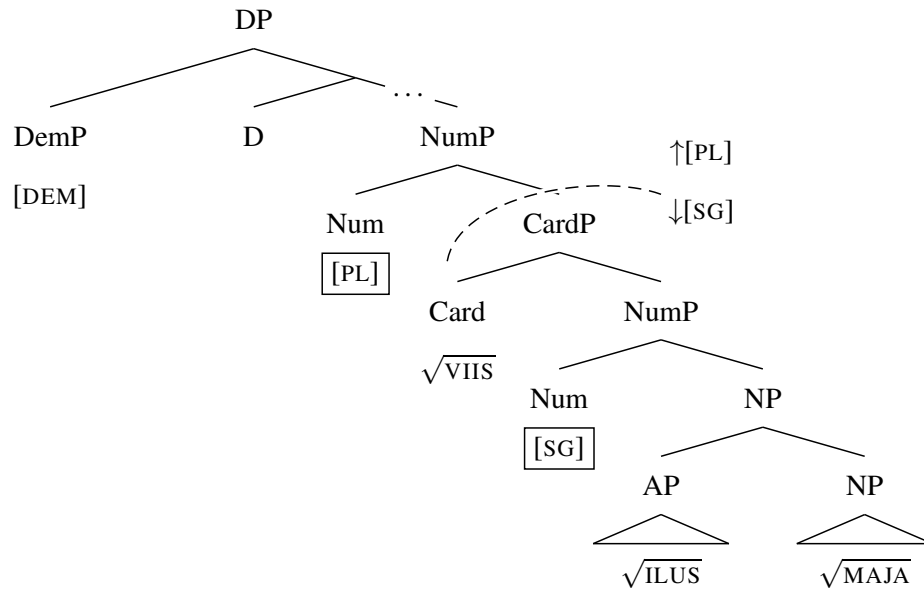

For readability, I note only the origins of the features in (259). The dashed arc indicates the upper bound of the percolation of the singular feature.

3.4.2.2 Alternative analyses of number-marking in numeral-noun constructions

Before continuing, I would like to take a moment to consider an alternative to the analysis of number-marking I just proposed. This alternative questions the assumption that there are two number features introduced by different syntactic heads. Suppose instead that there is only one Num⁰ head and only one number feature in numeral-noun constructions. Concretely, the plural that is introduced for higher elements is just the normal [NUMBER]-introducing Num⁰ head, *contra* the analysis I proposed in chapter 2. I call this the High NumP analysis. To be sure, this would be a non-standard position for a Num⁰ head crosslinguistically, as it is typically taken to dominate only NP (or α P, which itself dominates NP (Deal 2013a)), but this Num⁰ head would

need to contain more material in its complement than is typically assumed for NP (including numerals and possessors).

(260) High NumP analysis:

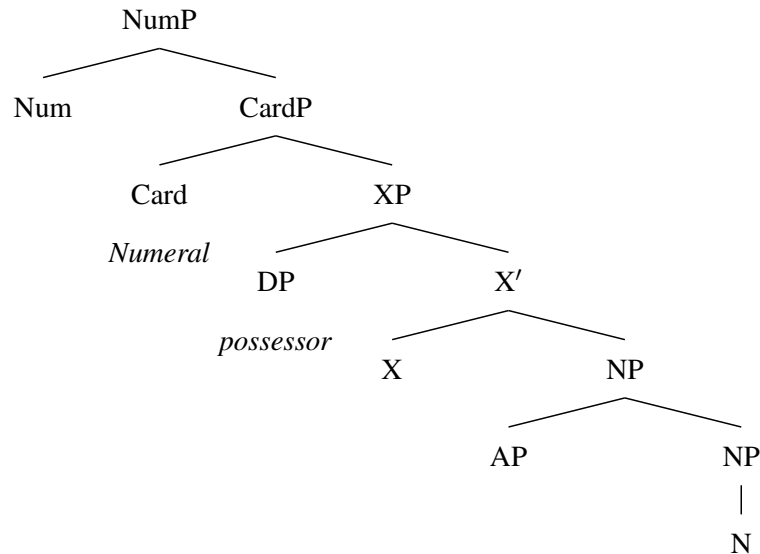

This structure is nearly identical to the one I have proposed— the only difference is that under the High NumP analysis, there is no lower number feature. The fact that the lower nominal elements apparently bear singular is due to Estonian’s morphology— in reality, they lack a value for [NUM], or perhaps, they do not have a number feature at all (Farkas & de Swart 2010). This is certainly an appealing aspect of the analysis, especially considering the fact that singular is typically the morphological default crosslinguistically.

The reason I do not adopt it is the fact that this makes simple plural DPs (that is, those with no numerals) more complicated. In a simple plural DP, every CE must be plural— singular is not a possibility, even for the noun or adjective.

(261) kōik nee-d ilus-*(ad) maja-*(d)
 all.PL this-PL.NOM beautiful-PL.NOM house-PL.NOM
 ‘all these beautiful houses’

In the absence of a numeral, every element within the DP must bear the same number value. However, if it is possible—or more strongly, required—for elements merged below Num⁰ to remain numberless when a numeral is present, why is that possibility excluded in the absence of a numeral? The approach I assume here holds that the use of a cardinal numeral coincides

with an extra syntactic head introducing an extra number feature. Without the numeral, there is only one such head; thus, we expect only one number feature.

It is at this point that I would like to briefly compare the Feature Percolation Principles to Feature Unification of the kind common in lexicalist frameworks such as G/HPSG and LFG, and used by Wechsler & Zlatić (2003) and Grimshaw (1991/2005) to (among other things) analyze nominal concord. In these analyses, agreement (that is, concord) is enforced by requiring the feature sets of merging elements to unify. Unification is only successful if the two elements have feature values that do not conflict. If they do conflict, then unification fails, and the derivation crashes. One of the strengths of this approach is that simple concord comes for free—the only way for a derivation to converge is if every element bears the same value for all the relevant features. A derivation that tries to combine the demonstrative *these* with the singular noun *pineapple* cannot converge.

However, as we saw in numeral-noun constructions, CEs in one DP do not all need to bear the same value. In these examples, higher elements are plural and lower elements are singular. As I understand it, Feature Unification as used by Grimshaw (1991/2005) and Wechsler & Zlatić (2003) predicts that such cases should not exist, as a higher demonstrative and a lower nominal constituent should be unable to unify. This is the key difference between the Feature Percolation Principles and Feature Unification: Percolation (as I have defined it here) does not require unification. Thus, when two elements merge with differing feature values, there is not a crash or failure of any kind—the higher value (i.e., the value of the head) simply “wins,” and the lower value percolates no further. While it is true that concord does not come for free in such a system, I believe the greater empirical coverage that it offers is worth that loss.

At the moment, it seems the most promising approach is one that posits an additional number feature merged above the numeral head, as I proposed in chapter 2. I thus follow the spirit (but not the letter) of this recent work on semantic and syntactic feature clash (Matushansky 2009, Ouwayda 2013, Pesetsky 2013). The Estonian facts are similar to the other cases of feature clash in that the syntactically higher feature could be argued to be the feature that most closely represents the semantics of the nominal in question—in other words, a DP with a numeral clearly refers to a non-atomic set of individuals, and thus [PLURAL] could certainly be said to be the “semantic” number value for a numeral-noun construction. However, the Estonian facts are different in that the cases referenced above are all optional: semantic gender agreement

is not obligatory in Russian, and plural verb agreement with DPs marked singular is optional in Lebanese Arabic. In Estonian, the material merged higher than these numerals *must* be plural.

I believe the view of “semantic agreement” espoused by those works— namely, that the “semantic features” are present in the syntax— is the most compatible hypothesis that is consistent with Minimalist views of syntax. These features are clearly referenced by both syntax and morphology, so they must be accessible there.²⁴ It is certainly interesting that “semantic agreement” is optional in the examples investigated by Matushansky, Ouwayda, and Pesetsky, but I will not seek a deep explanation for the fact that is not optional in Estonian.

3.4.3 Case features spread from top to bottom

It is immediately clear that something different must be said about case features, as their value does not come from the N^0 head. Rather, case values depend on the DP’s position in the clause. I assume case feature values are assigned to maximal projections. Case is generally assigned to full DPs, but numeral-noun constructions suggest that case can also be assigned to smaller projections. In contrast to features like gender and number, the prevailing viewpoint on the spread of case features is that they spread downward (Babby 1987, Matushansky 2008, Pesetsky 2013, Richards 2012), contra Chomsky (1965:174–5). Thus, case is first assigned to a maximal projection, and this case value is then spread to the elements dominated by that projection. This is schematized in (262).

²⁴There is some evidence from verbal agreement that is reminiscent of the observations made by Ouwayda and Pesetsky. Verb agreement with numeral-noun constructions in Estonian is sometimes singular, sometimes plural. The generalization reported by Erelt et al. (1993b, 2000) is that pre-verbal subjects prefer plural verbs and post-verbal subjects prefer singular verbs (as in (i)), though there are exceptions. That being said, if a plural modifier is present, then plural agreement becomes *obligatory*, even for post-verbal subjects (see (ii)).

- (i) Selle-s maja-s ela-s /^{??}ela-si-d neli perekonda.
 this-INE house-INE live-PST.3sg / live-PST-3PL four.NOM family.PAR
 ‘In this house lived four families.’
- (ii) Selle-s maja-s *ela-s /ela-si-d nee-d neli perekonda.
 this-INE house-INE live-PST.3SG / live-PST-3PL this-PL.NOM four family.PAR
 ‘In this house lived these four families.’

Without an analysis of singular agreement with numeral-noun constructions in hand, we cannot conclude anything concrete about these examples, but I note that they follow the same patterns as Ouwayda and Pesetsky’s observations: once plural is present, the lower singular value is no longer accessible.

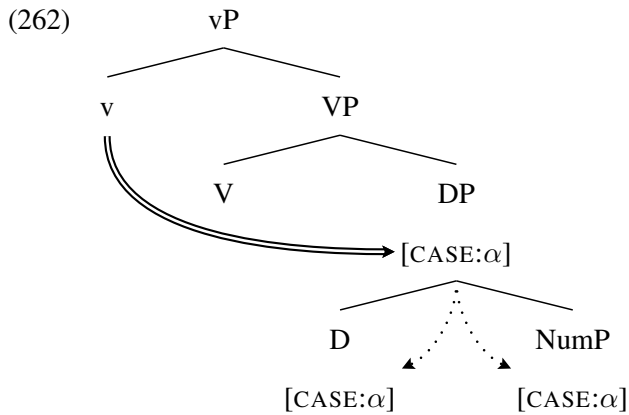

This is captured by Matushansky (2008) and Pesetsky (2013) by rule: when case is assigned to a constituent, that value is also assigned to elements dominated by that node. As with ϕ -feature percolation, it is quite clear how this works in cases of simple concord: case spreads from the top of DP all the way down to N^0 . However, in numeral-noun constructions, there is a case-assigner internal to the DP: Card^0 . As we already know, nominative/accusative case assigned to the numeral-noun construction DP does not surface on the complement of Card^0 in numeral-noun constructions. We could account for this by proposing the case feature values cannot spread to a node that already has a case value.

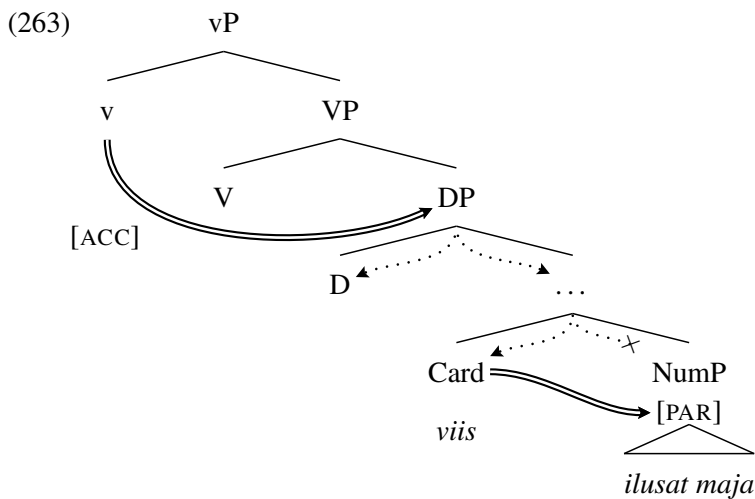

In this light, case spreading becomes somewhat of a last resort operation, spreading case feature values only where they do not already exist.

However, some contexts superficially similar to that depicted in (263) yield different empirical results. We have already seen examples of this.

- (235) a. kahe-l koosoleku-l
two-ADE meeting-ADE
'in two meetings' (PARLIAMENT)
- b. viie-s viimase-s matši-s
5-INE final-INE match-INE
'in the final five matches' (BALANCED)

Thus, when an entire numeral-noun construction is assigned adessive case or inessive case, those cases apparently overwrite the partitive case assigned by Card^0 to its complement. The proper analysis of such facts is complicated and I will take it up in section 4. The question will boil down to whether one and the same projection can have two case values or not. This phenomenon is apparently possible in some languages, where one nominal can bear more than one overt case suffix (Plank 1995, Richards 2012). This kind of analysis has also been extended to languages where only one overt morphological case is possible (Matushansky 2008, Baker & Vinokurova 2010, Brattico 2011, Pesetsky 2013). These analyses propose morphological algorithms or Spell-Out rules (Vocabulary Items) that realize these multiply case-marked lexical items with one case affix.

For now, I will simply assume that case spreading *cannot* overwrite previously assigned case values. I present an initial formalization of a case concord rule in (264):

- (264) Case Concord (to be further explored in chapter 4):
- a. Let X and Y be two nodes in a single extended projection, Y immediately dominating X.
 - b. If Y has a valued case feature $[\text{CASE}:\alpha]$ (but X does not), then copy Y's case feature to X.

Just as before, this rule of case spreading will define locality domains within numeral-noun constructions that predict the proper distribution of partitive case on the one hand and nominative/accusative case on the other. If we add these domains into the representation given in (259), we end up with the representation built in the syntactic component in (265).

- (265) nee-d viis ilusa-t maja
this-PL.NOM five beautiful-PAR house.PAR
'these five beautiful houses' (Erelt et al. 1993b:143)

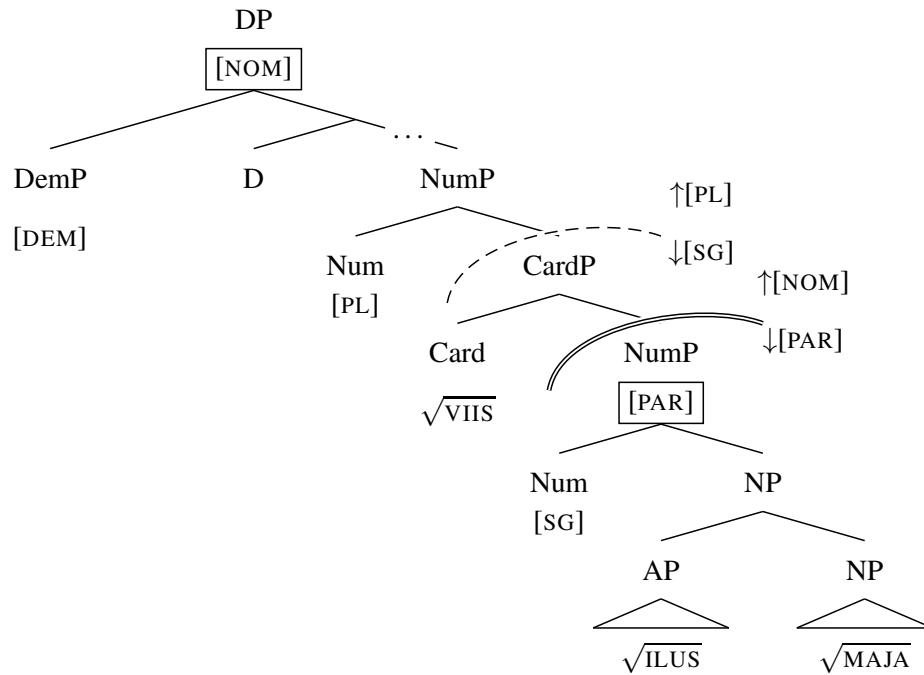

Again, for reasons of readability, I indicate only the origins of the features as well as their domains. The double-lined arc above NP delineates the barrier between nominative case (above) and partitive case (below). The dashed arc above CardP delineates the barrier between singular number (below) and plural number (above). These domains do not line up exactly, and cardinal numerals—the only CEs that are singular and nominative—are right in between them. These domains will serve as the starting point for the morphological component, which I turn to now.

3.5 The morphological side of concord

I have claimed that there is nothing different about the syntax of a language with concord from the syntax of a language without concord. What we have seen thus far is, I claim, universal. It is only after a DP is sent to Spell-Out that the morphological requirements of the language (i.e., the fact that a language has nominal concord) come into play. There are two aspects to a theory of nominal concord that I will address in this section.

1. What words (or categories) show concord in the language?
2. How do those words acquire the particular feature values they express?

The tentative answer I provide to the first question is that speakers must learn and memorize the categories (or words) that show concord in their language. Speakers must learn that, e.g., adjectives in Estonian must express number and case features to be morphologically well-formed. To formalize this, I make use of Agr⁰ nodes, which are inserted in the morphology to satisfy morphological requirements of the language (Kramer 2010, Norris 2012, Noyer 1997).

The answer that I provide to the second question is that, essentially, Agr⁰ nodes acquire their features from the closest place that has them. The notion of closest that I will propose is relevant for concord is inclusion. This is the sense in which concord is an indicator of membership: in a language with nominal concord, CEs express the feature values of the constituents that contain them. The feature acquisition is formalized by an operation of Feature Copying, which copies the relevant feature values into the Agr⁰ nodes from a local source.

3.5.1 Agr⁰ node insertion

An Agr⁰ node is a DISSOCIATED MORPHEME: a morpheme with no syntactic effects which is inserted after the syntax is complete (Embick 1997). Though Agr⁰ nodes often figure into Distributed Morphology analyses of agreement, there is not much work investigating the theory in detail. There are some important unanswered questions concerning their constraints and use. For example, it is not clear what conditions the presence of Agr⁰ nodes. I assume here that they are inserted for morphological well-formedness reasons, but I will leave open the question of where such reasons are to be stated in the grammar.

3.5.1.1 Agr⁰ node insertion is head-driven

I propose that Agr⁰ node insertion is governed by a rule schematic like the one in (266) (see Kramer 2010, Norris 2012 for formalizations of this type).

(266) Agr⁰ Node Insertion:

$$X^0 \rightarrow [X^0 \text{ Agr}^0]_X$$

This rule is a schematic: a formalization of the generalization that a particular word or category requires agreement information to be well-formed. In truth, it seems to me that Agr⁰ node insertion must be driven by the heads that show concord. It is the CE itself which triggers insertion of an Agr⁰ node.

This is one place where crosslinguistic variation—and even variation within one language—is located. Because the characterization of concord is often taken for granted, there is still much that we do not know about its behavior. In particular, it is not clear what kinds of generalizations there are about which categories are more likely to show concord. The systems for Icelandic, Estonian, French, and English are represented in 3.4. This table is clearly not a

LANGUAGE	Q	Dem	D	Card	Poss	A
Icelandic	✓	✓	✓	✓	✓	✓
Estonian	✓	✓	✓	✓		✓
French	✓	✓	✓		✓	✓
English		✓	✓			

Table 3.4: Some possible arrangements of categories showing concord

typologically-balanced sample, but I will treat it as representative for the following discussion. The columns in table 3.4 are syntactic categories, and a checkmark indicates that there are words belonging to that category which show concord. In terms of the Agr⁰ node hypothesis, this means that Icelandic applies (266) to Q⁰, Dem⁰, D⁰, Card⁰, A⁰, and possessors (which may actually just be another form of D⁰ (Dobrovie-Sorin & Giurgea 2011)).

One coherent hypothesis is that categories closer to the noun are more likely to show concord in a given language, but this does not appear to be the case. Adjectives very often show concord, as do demonstratives and determiners, but numerals are less likely to. In Icelandic, for example, it is only the numerals one through four that show concord. All others are invariant.

(267) Agreeing numerals in Icelandic

- a. tveir / þrír / fjórir kett-ir
two.AGR / three.AGR / four.AGR cat-MASC.PL.NOM
'two / three / four (male) cats'
- b. tvær / þrjár / fjórar kis-ur
two.AGR / three.AGR / four.AGR cat-FEM.PL.NOM
'two / three / four (female) cats'

(268) Non-agreeing numerals in Icelandic

- a. fimm / tíu / hundrað kett-ir
five / ten / hundred cat-MASC.PL.NOM
'five / ten / a hundred (male) cats'

- b. fimm / tñu / hundrað kis-ur
 five / ten / hundred cat-FEM.PL.NOM
 ‘five / ten / a hundred (female) cats’

Furthermore, numerals (beyond *un(e)*) ‘one’, homophonous with the singular indefinite article) in French do not show concord at all. Concord in French is otherwise quite rich. Anecdotally, it seems to be that demonstratives/articles and adjectives regularly show concord in languages that have it, but this does not strike me as a natural class.²⁵

There is also some amount of variation within single languages. For example, though most elements of the syntactic category A^0 must show concord in Estonian, there are some elements that do not show concord but may still be A^0 heads. One clear example is the difference between present and past participial adjectives. Recall that present participial adjectives show concord with the head noun, but past participial adjectives do not.

- (198) a. söö-va-te-le inimes-te-le
 eat-PRS.PCPL-PL-ALL person-PL-ALL
 ‘to eating people’
- b. söö-da-va-te-le õun-te-le
 eat-PASS-PRS.PCPL-PL-ALL apple-PL-ALL
 ‘to apples to be eaten / to edible apples’
- (199) a. söö-nud inimes-te-le
 eat-PST.PCPL person-PL-ALL
 ‘to people who have eaten’
- b. söö-dud õun-te-le
 eat-PASS.PST.PCPL apple-PL-ALL
 ‘to the eaten apples’

There is no reason that I know of to believe that the present PAs in (198) are syntactically different from the past PAs in (199), yet only the former show concord. I will not seek a deep explanation for these facts here— it is simply a property of Estonian that must be learned.²⁶

Perhaps future crosslinguistic study of concord will reveal some trends with respect to which categories show concord that can be tied to independently observable facts, but until that

²⁵I have seen a reference to Corbett (2006) for the claim that adjectives are the most likely category to show concord. However, I have been unable to find that particular claim there.

²⁶Interestingly, the agreement patterns are reversed in Icelandic. Past participles show concord with the nouns they modify, but present participles are invariant (Einarsson 1949).

time, I propose that whether or not a category or word shows concord must be stipulated. In more formal terms, learners must acquire which categories the rule in (266) applies to. The intuition that Agr^0 nodes are intended to capture is that concord is a morphological phenomenon: the words that show concord must express certain features in order to be well-formed words.

3.5.1.2 The content of Agr^0 nodes

Another question that a theory involving Agr^0 nodes should address is what content Agr^0 nodes contain. If Agr^0 node insertion concerns which categories show concord, then the content of Agr^0 node concerns how we indicate the features that a CE must express. Consider, for example, the fact that concord in Estonian looks like Table 3.5 and not Table 3.6. The generalization in

ELEMENT	CASE	NUMBER
Quantifier	✓	✓
Demonstrative	✓	✓
Numeral	✓	✓
Adjective	✓	✓
Noun	✓	✓

Table 3.5: Feature expression by CEs in Estonian concord

ELEMENT	CASE	NUMBER
Quantifier	✓	✓
Demonstrative	✓	
Numeral	✓	
Adjective		✓
Noun	✓	✓

Table 3.6: An impossible pattern of feature expression in Estonian concord

Estonian is that, if a word shows concord, it shows concord for both number and case. This can be captured by assuming that there is only one nominal Agr^0 node in Estonian, and it is born with unvalued features for case and number.

(269) Estonian nominal Agr node:

$$\text{Agr}_N \left[\begin{array}{l} \text{CASE: } __ \\ \text{NUM: } __ \end{array} \right]$$

The empirical import of this claim is that in Estonian, if a category is to show concord, it must show concord in case and number. In this sense, concord in Estonian is systematic.

Not every language with nominal concord behaves in this way. The concord system of Nez Perce (as described in Deal 2010 and Deal 2013a) could be described as less systematic or uniform than that of Estonian. The features that are involved in Nez Perce are case, number, and animacy ([±HUMAN]). I refer readers to the works cited for a more complete picture, but some examples are provided in (270)–(272), and the distribution of features is given in Table 3.7.

- (270) yoosyoos(-na) wixsilikeecet'es-ne
 blue-OBJ chair-OBJ
 'the blue chair' (Deal 2010:33)
- (271) ki-kuhet ti-tíyaw'ic wiḥsi'likeecet'es
 PL-tall PL-sturdy chair
 'tall, sturdy chairs' (Deal 2013a:8)
- (272) lep-it nicka'niicka' / lep-u'-ne ha-'ayat-ona
 two-SUF strawberry / two-HUM-OBJ PL-woman-OBJ
 '2 strawberries' / '2 women (objective case)' (Deal 2013a:10/14)

ELEMENT	CASE	NUMBER	HUMAN
Quantifier			(✓)
Demonstrative	(✓)	✓	
Numeral	(✓)		(✓)
Possessor	(✓)		
Adjective	(✓)	✓	

Table 3.7: The distribution of features in Nez Perce concord

The distribution of features in Nez Perce appears idiosyncratic when compared to Estonian. Demonstratives and adjectives show the same concord possibilities, but other than that, each category expresses a unique set of features.

What Nez Perce concord suggests to me is that, in addition to dictating whether or not they show concord at all, heads may choose which features they must express. In Nez Perce, quantifiers are categories that show concord, and furthermore, they are categories that only show concord for the feature [HUMAN]. Adjectives are categories that show concord, and they do not show concord for the feature [HUMAN]. There are two ways that we could conceptualize

concord in Nez Perce. Either there are individual Agr⁰ nodes for each feature (as in (273)), or the features come bundled in Estonian, but there are just more Agr⁰ nodes (as in (274)).

- (273) a. Agr₁
 $\left[\begin{array}{l} \text{CASE:} ___ \end{array} \right]$
- b. Agr₂
 $\left[\begin{array}{l} \text{NUM:} ___ \end{array} \right]$
- c. Agr₃
 $\left[\begin{array}{l} \text{ANIM:} ___ \end{array} \right]$
- (274) a. Agr₁
 $\left[\begin{array}{l} \text{CASE:} ___ \\ \text{NUM:} ___ \end{array} \right]$
- b. Agr₂
 $\left[\begin{array}{l} \text{CASE:} ___ \\ \text{ANIM:} ___ \end{array} \right]$
- c. Agr₃
 $\left[\begin{array}{l} \text{CASE:} ___ \end{array} \right]$
- d. Agr₄
 $\left[\begin{array}{l} \text{NUM:} ___ \end{array} \right]$
- e. Agr₃
 $\left[\begin{array}{l} \text{ANIM:} ___ \end{array} \right]$

Note that in both cases, individual words or categories must specify which Agr⁰ node(s) they use. Note further that the set of Agr⁰ nodes in (273) is a proper subset of the Agr⁰ nodes in (274).

The existence of both the Nez Perce pattern and the Estonian pattern also raises the question of whether there are crosslinguistic tendencies for concord to look more like Nez Perce's system or more like Estonian's. This is another area in need of more careful investigation of systems of concord. It seems clear that systems of concord in the languages of Europe tend to be more systematic (i.e., Estonian-like). This is also true for many Bantu languages. Kramer's (2009) discussion of the Ethiosemitic language Amharic also suggests that its system of concord is largely systematic. Perhaps the crosslinguistic picture is bimodal, with some languages' concord systems being systematic and others being idiosyncratic. Yet, it also seems reasonable that there is a gradient in between Estonian and Nez Perce. This is not a question that I can answer here, but it is one that should be kept in mind as our understanding of the typology of concord systems develops.

3.5.2 Feature Copying

As we saw with numeral-noun constructions in Estonian, CEs acquire their features from a local source. This is particularly clear with numerals, which are the only element situated in the

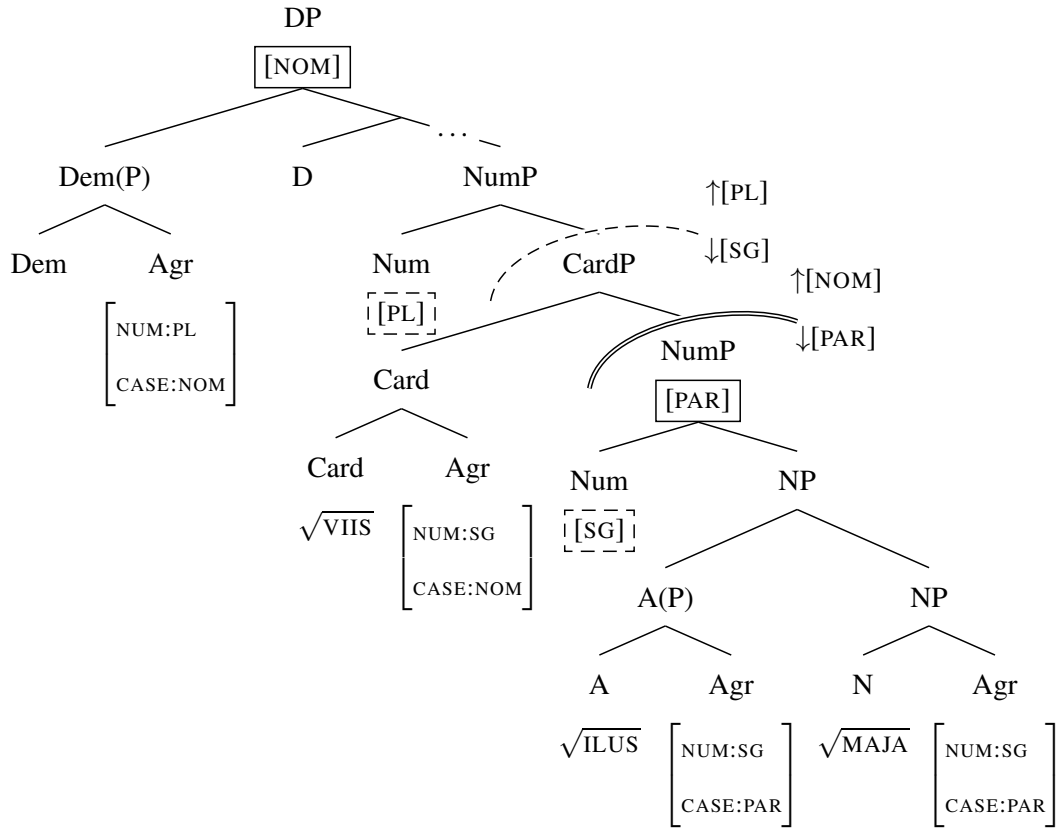

The domains for the two number features and the two case features are established in the syntax by the mechanisms of feature spreading discussed in section 3.4. Once these domains are established, concord can be determined then solely on the basis of position of attachment in the DP. In other words, where a CE (or some constituent containing it, as in the case of adjectives) merges with the main spine is what determines the feature values that it will show in concord. Under the analysis just proposed, concord is not agreement with the head noun as traditionally described. Instead, it is certain categories expressing features of the the phrase they are a part of, whose lexical head happens to be a noun.

3.6 Conclusion

This chapter had two goals. First, I aimed to discuss nominal concord from a theoretical vantage point in a way that took seriously concord's differences from other superficially similar empirical phenomena. Concord is often described as certain elements "agreeing with the head noun."

This definition applies quite simply in cases of simple concord, where every CE bears features of (gender), number, and case, with the same values as the head noun. However, implementing this formally is not a trivial matter, as concord seems to care less about syntactic position than the well-studied other kinds of agreement. I argued that nominal concord is a fundamentally different phenomenon from subject-verb agreement. Formally analyzing the two in the same way leads to complications for the agreement mechanism assumed— here, I focused on Agree. To be sure, it may be the case that concord in some languages can be straightforwardly analyzed using the same mechanisms as e.g., subject-verb agreement, but we must think carefully about what such analyses reveal about the nature of concord and the nature of agreement more broadly. I argued here that treating concord as a different kind of agreement descriptively and formally allows us to better understand concord’s behavior. Furthermore, it prevents us from having to propose complicated modifications to theories of subject-verb agreement simply on the basis of concord.

The second goal of this chapter was to provide an analysis of the patterns of complex concord found in Estonian numeral-noun constructions. Numeral-noun constructions in Estonian show that it is descriptively false that CEs “agree with the head noun,” as they instantiate examples where a high element like a demonstrative agrees with the head noun neither in number nor in case. The theory of concord I proposed to analyze these patterns has two components: Feature Percolation and Case Concord take place in the narrow syntax, and those features are realized by CEs in the postsyntactic component. Feature Percolation and Case Concord set up featural domains, and within a domain, every CE is consistent. This view is summarized in Table 3.8, and the formalizations proposed in this chapter are repeated below.

CONCORD	
<i>Syntax</i>	<i>Morphology</i>
<ul style="list-style-type: none"> • Feature Percolation • Case Concord 	<ul style="list-style-type: none"> • Agr⁰ node insertion • Feature Copying from closest dominating sources

Table 3.8: The syntax and morphology of concord

(242) Feature Percolation Principles:

- a. All projections of a head X^0 have the feature-value pairs that X^0 has.
 - b. Let $[F:val]$ be a valued feature on XP.
Let Z^0 be a head lacking the feature $[F]$.
Let X^0 and Z^0 be members of the same extended projection (i.e., both $[+N]$).
When Z^0 merges with XP, projecting ZP, ZP also has the valued feature $[F:val]$.
- (264) Case Concord (to be further explored in chapter 4):
- a. Let X and Y be two nodes in a single extended projection, Y immediately dominating X.
 - b. If Y has a valued case feature $[CASE:\alpha]$ (but X does not), then copy Y's case feature to X.
- (266) Agr⁰ Node Insertion:

$$X^0 \rightarrow [X^0 \text{ Agr}^0]_X$$
- (275) Feature Copying (concord): For every unvalued feature $[F:_____]$ on an Agr node Z_{Agr} , copy the value from a projection XP iff...
- a. XP has a value for $[F:_____]$ ($[F:\alpha]$)
 - b. XP includes Z_{AGR} ,
 - c. There is no YP such that YP has a value for $[F:_____]$, YP dominates Z_{AGR} , and XP dominates YP (**i.e., copy the closest value**)

After exploring this case of complex concord in Estonian, it is worth returning to cases of simple concord: situations where every CE bears the same value for gender, number, and case. In the account developed in Norris 2012, this was a direct result of the Feature Copying relation, which copied feature-value pairs to CEs from one and the same source. From the perspective of the analysis developed here, simple concord is epiphenomenal. Every element bears the same feature value in cases of simple concord because there is only one value available for each feature. This makes it appear as though CEs are agreeing with the head noun. However, when more than one value becomes available, we see the emergence of locality in concord. An element can “show concord” without matching either of the features of the noun. Concord is not agreement with the head noun; it is a member of the nominal extended projection expressing certain features of that projection.

More broadly, I proposed that the *syntax* of a language with concord is minimally different from the syntax of a language without concord. This reflects a view of concord as a morphological requirement that certain categories must express a certain set of features in order to be well-formed words. Concretely, I argued that concord is not predicated on a syntactic Agree relationship between the CE and the source of the feature(s) it expresses. My proposal is thus in line with the view that not all morphological agreement is rooted in the syntactic relation Agree, and we should accordingly be very cautious in constructing arguments about agreement mechanisms (like Agree) on the basis of their ability to generate concord data.

I also argued that concord is not the DP-internal correlate of subject-verb agreement. There is another form of DP-internal agreement that I believe more clearly fits the bill. Consider the kind of agreement seen between possessed nouns and their possessors, often concomitant with case-marking. Some examples from Turkish and Hungarian are given below.

- | | |
|------------------------------------------------------------------------------------------------------------------------------------------------------------------------------------------|----------------------------------------------------------------------------------------------------------------------------------------------------------------------------------------|
| (277) Turkish (Kornfilt 1997) | (278) Hungarian (Szabolcsi 1994:186-7) |
| <ul style="list-style-type: none"> a. ben-im kitab-ım
1SG-GEN book-1SG.POSS
'my book' b. Hasan-ın kitab-ı
Hasan-GEN book-3SG.POSS
'Hasan's book' | <ul style="list-style-type: none"> a. az én kalap-om
the 1SG.NOM hat-1SG.POSS
'my hat' b. az ő kalap-ja
the 3SG.NOM hat-3SG.POSS
'his/her hat' |

This kind of agreement is often called POSSESSOR AGREEMENT. In possessor agreement, the person and number features of the possessor are marked with a suffix on the possessum.

There are a number of immediate similarities between possessor agreement and subject-verb agreement. First, both are generally expressed only once, on the head noun. Possessor agreement does not get marked on attributive adjectives and the head noun, for example. Second, they are both relationships between two separate extended projections. In possessor agreement, the extended projections are of the same type, but they are distinct. Third, they both arguably have a relationship to case assignment. The possessor is assigned case and the possessum bears agreement. Fourth, they both regularly involve agreement for person, which is almost completely absent from concord (see Baker 2008 for one possible example of person concord from Bantu). Taken together, the similarities are striking.

In fact, the original proposals drawing parallels between the nominal and clausal domains

on the basis of agreement claim that the DP-internal correlate of subject-verb agreement is *possessor agreement* (Abney 1987, Szabolcsi 1994). Under Abney's (1987) analysis, the possessor agreement marker is a D⁰ head agreeing with its specifier, which is similar to the relationship between T⁰ and the subject. Furthermore, concord and possessor agreement can exist in a single language. Estonian's close relative, Finnish, is one such example. Importantly, possessor agreement in Finnish is marked only once (on the noun), but concord in Finnish follows the pattern in Estonian. It is marked, for example, on adjectives.²⁸

(279) Finnish concord and possessor agreement:

- a. iso-ssa(*-ni) talo-ssa-ni
 big-INE(*-POSS.1 SG) house-INE-POSS.1 SG
 'in my big house'

- b. punaise-ssa(*-ni) auto-ssa-ni
 red-INE(*-POSS.1 SG) car-INE-POSS.1 SG
 'in my red car'

If both concord and subject-verb agreement are analyzed with the same syntactic mechanism (e.g., Agree), it seems mysterious that they have different distribution. If, as I argue, concord is a different relationship, then we do not expect concord and possessor agreement to be marked in the same places. This is certainly true for Finnish.²⁹ In the view I propose, there are at least two kinds of "agreement." One type is indicative of a relationship between two different extended projections (i.e., subject verb agreement, possessor agreement). The other type is the membership relation indicative of a word's relationship to the extended projection that contains it. This is nominal concord.³⁰

Some aspects of the theory of concord I propose are intended to be universal, but some are intended to be language-particular. That being said, I have focussed exclusively on Estonian to develop the theory. It remains to be seen whether concord in Estonian, which is both rich and obligatory, is the exception or the rule. However, with a theoretical framework for concord that respects its differences from other kinds of agreement, we are better equipped to investigate its

²⁸Another possible example is Skolt Saami, another relative of Estonian. Feist's (2010) grammar indicates that both concord and possessor agreement exist in Skolt Saami, but there were no examples where it was clear that the two were co-occurring in one and the same DP.

²⁹See Toivonen 2000 for some discussion of possessor agreement in Finnish.

³⁰An important question is whether we see a correlate of concord in the verbal domain. If such a thing exists, it is certainly rarer than nominal concord. I discuss some possible examples in chapter 5.

cross-linguistic properties.

In the next chapter, I will further refine the understanding of case concord presented here by looking in more detail at case concord in Estonian pseudopartitives and numeral-noun constructions.

Chapter 4

An Unmarked Case in Estonian Nominals

4.1 Introduction

The term CASE CONCORD has come to be used to describe situations where various modifiers inside DP inflect for case in addition to the head noun. We have seen plenty of examples of this from Estonian thus far.

(280) kõigi-s nei-s raske-te-s küsimus-te-s
all.PL-INE these.PL-INE hard-PL-INE question-PL-INE
'in all these hard questions' (BALANCED)

(281) nee-d närvilise-d ja riiaka-d oota-ja-d
these-PL.NOM irritable-PL.NOM and cantankerous-PL.NOM wait-er-PL.NOM
'these irritable and cantankerous waiters (i.e., people who are waiting)' (Kaplinski 1977)

In the last chapter, I adopted the fairly standard view from the literature that case is a feature of maximal nominal projections (often DP, though not always DP), and that case concord can be conceptualized as the downward spread of case feature values to the elements contained in a maximal projection (see, e.g., Babby 1987, Chomsky 1981, 1986, Delsing 1993, Matushansky 2008). This is represented schematically in (282).

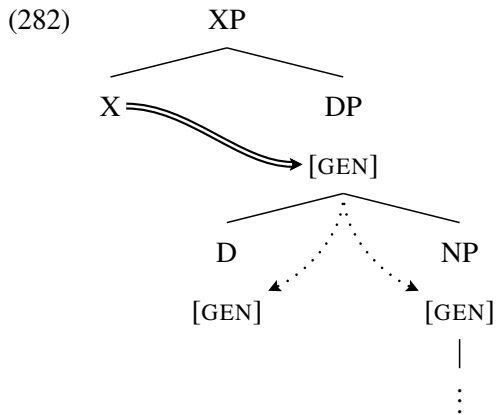

In (282), X^0 assigns genitive case to DP, and then DP passes that value to its daughters, D^0 and NP, who then pass it to their daughters, and so on.

In this chapter, I will push this understanding of case concord further by looking at an alternation in case-marking visible in Estonian pseudopartitives. The following examples show this alternation.

(283) a. hulk inimesi
group.NOM person.PL.PAR
'a bunch of people'

b. hulga-l inimes-te-l
group-ADE person-PL-ADE
'on a bunch of people'

(284) a. klaas vett
glass.NOM water.PAR
'a glass of water'

b. klaasi-s vee-s
glass-INE water-INE
'in a glass of water'

In the (a) versions above, the first noun is in nominative case, and the second noun is marked with a case called partitive. In the (b) versions above, both nouns are marked with the same case (adessive in (283b), inessive in (284b)). The core question is the following: how is the case system of Estonian structured such that this alternation comes to exist? More broadly, what does the existence of such an alternation tell us about the behavior of case in natural language?

Estonian is an ideal language to investigate these kinds of alternations, because the alternation seen above exists in more than one kind of syntactic context. The same alternation can be seen in numeral-noun constructions in Estonian (see (285)), and likewise in a construction that combines the pseudopartitive with a numeral-noun construction (see (286)).

- (285) a. kaks inimes-t
 two.NOM person-PAR
 ‘two people’
- b. kahe-l inimese-l
 two-ALL person-ALL
 ‘on two people’
- (286) a. kolm kotti kartule-id
 3.NOM bag.PAR potato-PL.PAR
 ‘3 bags of potatoes’
- b. kolme koti kartuli-te
 3.GEN bag.GEN potato-PL.GEN
 ‘3 bags of potatoes (genitive)’

As before, in the (a) examples, we see the first element in nominative case and subsequent nouns bearing partitive case. However, in the (b) examples, every element bears the same case.

Briefly, what I will ultimately propose is that the partitive case that is assigned in these constructions emerges as a kind of default, assigned only when no other case is available. The reason there is no partitive case in any of the (b) examples above is because another case *is* available. The reason that partitive case emerges in the (a) examples is because that case (nominative) is assigned too late— the “last resort” partitive rule is applied before nominative case is assigned.

The organization of the chapter is as follows. In the next section, I will propose a syntactic analysis of the pseudopartitive construction, ultimately arguing that it is a DP-within-DP structure. In section 4.3, I will describe the case alternation more carefully, ultimately arguing that the situations showing partitive case and the situations not showing partitive case are complementary. This will involve a closer inspection of the case system of Estonian. In section 4.4, I review classical treatments of this alternation, which involve appealing to a stipulated case hierarchy, as well as modern attempts to derive such hierarchical effects from independent properties. I will show that those approaches would need to be revised in order to extend to Estonian. I propose one analysis in 4.5, ultimately showing that it is too restrictive to account

for all of the data. I then propose an alternative in 4.6, based on the idea that partitive inside nominals in Estonian is a kind of unmarked case in Marantz’s (1991) sense. I then briefly consider how the analysis I present can be extended to account for parametric differences between Finnish and Estonian in section 4.7 before concluding in section 4.8.

4.2 The syntax of the pseudopartitive

At this point, I will define some terminology. To clarify, I will use the term PSEUDOPARTITIVE to refer to nominals like those in (287) and (288).

(287) hargi-täis_{N1} põhku_{N2}
pitchfork-ful straw.PAR
‘a/the pitchforkful of straw’ (EKSS, entry for *hargitäis*)

(288) parv_{N1} pääsukesi_{N2}
flock swallow.PL.PAR
‘a/the flock of swallows’ (Nemvalts 1996:p.69)

For the two nominal elements in pseudopartitives, I will adopt the fairly transparent terms N1 (for the nominal on the left) and N2 (for the nominal on the right). The nominals have subscripts in (287) and (288), but I will not include subscripts in subsequent examples. We saw in chapter 2 that N2 can also contain modifiers of various kinds (to be specified momentarily). Thus, it will at times be useful to make reference to the “N2 PHRASE”.

(289) parv [mängleva-id delfine]_{N2 phrase}
flock playful-PL.PAR dolphin.PL.PAR
‘a/the flock of playful dolphins’ (EKSS, entry for *parv*)

In (289), N1 is *parv* ‘flock’, N2 is *delfine* ‘dolphins’, and the N2 phrase is *mänglevaid delfine* ‘playful dolphins’.

Before turning to theoretical treatments, I will comment briefly on number-marking in the N2 phrase. As we have seen many times, numerals in Estonian typically combine with singular nouns.

(290) a. kaks inimes-t / *inimes-i
two person-PAR / people.PL.PAR
‘two people’

- b. sada punas-t putuka-t / *punase-id putuka-id
 100 red-PAR bug-PAR / red-PL.PAR bug-PL.PAR
 ‘100 red bugs’

Pseudopartitives and numeral-noun constructions have essentially identical case-marking possibilities: sometimes, the (rightmost) noun is marked with partitive case. Otherwise, the quantifying element (N1/the numeral) match in case values. Setting aside the proper characterization of the case-marking patterns for now, note that pseudopartitives and numeral-noun constructions also differ in their number-marking. In numeral-noun constructions, the noun must be singular, but in pseudopartitives, the N2s can be plural. The most common pattern is that N2s that are mass nouns are singular, and N2s that are count nouns are plural (Nemvalts 1996):

(291) Mass nouns are singular:

- a. Seal oli kilo vorsti / meeter traati.
 there be.PST.3SG kilo sausage.PAR / meter wire.PAR
 ‘There was a kilo of sausage / a meter of wire.’ (Nemvalts 1996:68)
- b. Seal on hulk rahvas-t.
 there be.3 crowd folk-PAR
 ‘There is a crowd of people.’ (Nemvalts 1996:68)

(292) Count nouns are plural:

- a. Siin on kilo kurke / meeter rööpa-id.
 here be.3 kilo cucumber.PL.PAR / meter rail.PL.PAR
 ‘Here is a kilo of cucumbers / a meter of rails.’ (Nemvalts 1996:68)
- b. Siin on hulk inimesi.
 here be.3 crown people.PL.PAR
 ‘Here is a crowd of people.’ (Nemvalts 1996:68)

In (291), there are some examples of pseudopartitives with mass N2s, which must be singular. In (292), we see pseudopartitives with the very same N1s but count N2s, and these N2s must be plural. By and large, this seems to be true. The one exception that I have found is *lõik* ‘slice/section’, as in the following example:

- (293) lõik siidruni-t / kurki
 slice lemon-PAR / cucumber.PAR
 ‘a slice of lemon / cucumber’ (EKSS, entry for *lõik*)

Number-marking inside Estonian pseudopartitives is interesting insofar as plural is possible. As we have seen, typical numeral-noun constructions do not permit plural-marking on the head

noun. However, I will not address the choice between singular and plural in pseudopartitives in what follows. I will assume the characterization based on the mass/count distinction is largely right, though it is a simplification in some respects.¹

4.2.1 Pseudopartitives in a theoretical context

Theoretical treatments of pseudopartitives often focus on two core issues. First, what kind of element is N1? It certainly looks like a noun. In all languages that I am aware of, there is at least some overlap between the elements that can occupy N1 in a pseudopartitive construction and the elements that can serve as the head noun of a normal DP. Thus, one hypothesis would be that the N1 of a pseudopartitive is a lexical noun, as in (294).

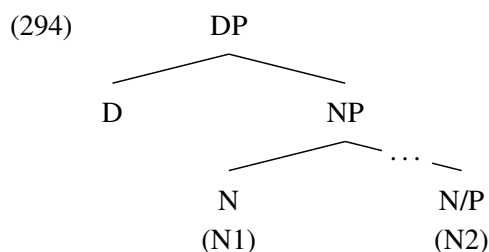

This is the analysis of N1 proposed by Grimshaw (2007) for the English pseudopartitive construction.

Others have argued that the N1 of a pseudopartitive is not a normal noun, but a functional head. To take one recent example, Hankamer & Mikkelsen (2008) make this proposal for pseudopartitives in Danish. They note three ways in which N1s in Danish behave differently from normal nouns (pp. 323–325): (i) they are unstressed, (ii) there are a number of N1s which are more restricted than normal nouns, and (iii) there are some N1s that are inflectionally deficient— they do not tolerate plural marking. Instead of analyzing N1 as being category N^0 , Hankamer and Mikkelsen assign it to the category n^0 , taking an NP complement.²

¹For example, as noted by Nemvalts (pp. 68–69), there are some N1s that do not permit mass N2s for reasons that he connects to their semantics. Further, it is well known that some mass nouns can be coerced into count nouns (as in the English *two coffees*), and some count nouns can be coerced into mass nouns (as in the English *some (mashed) banana* (see Copestake & Briscoe 1995 for theoretical discussion and Frisson & Frazier 2005 for an experimental investigation).

²Hankamer & Mikkelsen (2008) analyze N1 as a fully functional head, but an analysis with more proponents in the literature is that N1s are *semi-lexical* heads (Löbel 1989, van Riemsdijk 1998, Stavrou 2003). The semi-lexical analysis also holds that the entire pseudopartitive is one extended projection. For that reason, I will not address it

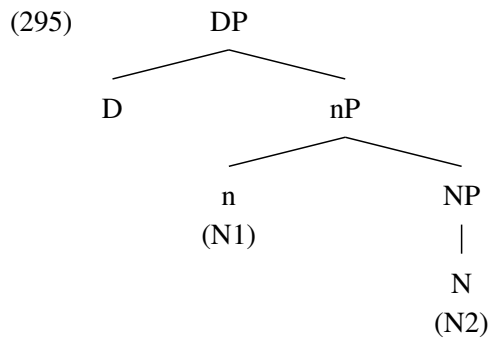

The second issue concerns the size of the N2 phrase. Again, there are two basic hypotheses here. Under one hypothesis, the N2 phrase is a normal DP. Under another view, the N2 phrase is reduced somehow— for example, an NP with no functional structure, or perhaps some functional structure, but not a full nominal extended projection. Though these issues are independent, there is a tendency for them to go together. Those who argue that N1 is lexical often argue that the N2 phrase is a full DP. Those who argue that N1 is functional argue that the N2 phrase is not a full DP.

I will adopt an analysis of pseudopartitives in Estonian that holds that they are unexceptional: N1 really is a noun, and the N2 phrase is a normal nominal extended projection (in line with (294) and Grimshaw (2007)). If this proposal is on the right track, then Estonian constitutes an argument for the view that pseudopartitive structures may be binominal (i.e., recursive), involving a measure noun (=N1) that is a normal noun embedding a full nominal extended projection. I will now turn to discussion of the first piece: the status of N1.

4.2.2 N1 is a normal noun

The clearest arguments I can see in favor of the status of N1 are from parsimony. Imagine a derivation in which an N2 phrase has been constructed, and this phrase is merged with an N1, as in (296) below, abstracting away from the identity of N1's complement for the moment.

directly.

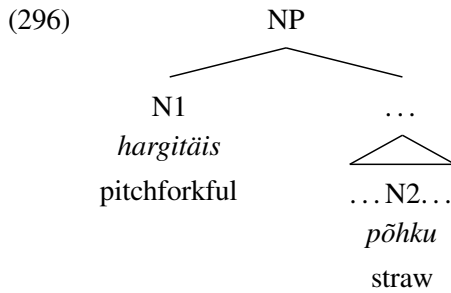

Consider what might be further merged with this structure. If N1 is an N^0 , then we predict that the elements that can merge with the structure in (296) are no different from the elements than can merge with a normal noun. If N1 is functional, then we might expect to see some restrictions on what can merge with this structure. Any cases of overlap would need to be stated separately. Hankamer & Mikkelsen (2008) assume, for example, that adjectives can be adjoined either to NP (i.e., N2P) or to nP (i.e., N1P). If N1 and N2 are the same lexical category, then these possibilities come “for free.”

What seems to be the case is that all functional elements that can modify a normal noun can also modify N1 in a pseudopartitive. Thus, demonstratives, numerals and possessors can freely appear to the left of N1.

(297) Demonstratives:

- a. see salk poisse
this group boy.PL.PAR
'this group of boys'
- b. see parv kajakaid
this flock seagull.PL.PAR
'this flock of seagulls'

(298) Possessors:

- a. mu klaas tee-d
1SG.GEN glass tea-PAR
'my glass of tea'
- b. konventsiooni rida artikle-id
convention-GEN row article-PL.PAR
'the convention's range of articles'

(PARLIAMENT)

(299) Numerals:

- a. kaht liiki sõralisi
two type.PAR ungulate.PAR
'two types of ungulate' (BALANCED)
- b. kaks ämbri-t vett
two bucket.PAR water.PAR
'two buckets of water' (LK, volunteered)

If N1 (underlined in the examples above) is simply a normal noun, then this is exactly what we predict. If N1 is not a normal noun, but a functional element, then the predictions are less clear. They depend on where this functional element is merged. Examples like those above suggest that, if N1 is functional, it must be merged quite low in the extended projection of the noun, as argued by Hankamer and Mikkelsen. If N1 is merged before demonstratives and possessors, then it is not surprising that they can modify the constituent containing N1.

It is not just material to the left of N1 that is relevant, though— material in between N1 and N2 is also important. Note that demonstratives and possessors can also occur as parts of the N2 phrase.³

(300) Demonstratives:

- a. terve rida [ne-id loomi]
whole row DEM.PL.PAR animal.PL.PAR
'an entire range of these animals' (PARLIAMENT)
- b. enamiku-l [nende-l juhtu-de-l]
majority-ADE DEM.PL-ADE situation-PL-ADE
'in a majority of these situations' (PARLIAMENT)

(301) Possessors:

- a. enamik [kooli-de direktoreid]
majority school-PL.GEN director.PL.PAR
'a majority of school directors' (PARLIAMENT)
- b. osa [väikesaar-te elanikke]
some small.island-PL.GEN inhabitant.PL.PAR

³The possibilities between N1 and N2 are not the same as the possibilities above N1, as strong quantifiers like *kõik* 'every' and *iga* 'each' cannot occur in between N1 and N2, and neither can cardinal numerals. The reason for this does not seem to be syntactic. For example, it cannot be about the size of the N2 phrase, because demonstratives are okay in N2 phrases, and they are merged higher than cardinal numerals, which are ungrammatical inside of N2 phrases. I will not attempt to characterize this semantic restriction here, but a promising line of attack would be to place a restriction on the possible semantic types of N2 phrase denotations (Ladusaw 1982).

‘some small island inhabitants’

(PARLIAMENT)

There seems to be universal consensus that N2 must be a normal noun— thus, in that respect, it is not surprising that N2 can be modified by demonstratives and possessors (though this is relevant for the analysis of the N2 phrase itself, so we will come back to this). However, the fact that these elements can also appear above N1 is telling. If both N1 and N2 are nouns, then these facts are unsurprising. However, under an analysis where N1 is not a lexical noun, but a functional element in N2’s extended projection, the fact that demonstratives can apparently be merged both high (above N1) and low (below N1) must be stipulated. If N1 and N2 are both nouns (and the N2 phrase is a normal DP), then we fully expect demonstratives in both positions.

Number-marking is also an empirical area where the status of N1 is relevant. In Hankamer & Mikkelsen’s discussion of Danish, they note that some N1s in Danish are inflectionally deficient in that they cannot show plural-marking. They take this as evidence in support of N1’s functional nature (or, more conservatively, as a difference between N1 and normal nouns). In Estonian, N1 can be marked for plural, as in the following examples:⁴

- (302) a. saali-täie-d koolilapsi
room-ful-PL.NOM schoolchildren.PL.PAR
‘roomfuls of schoolchildren’ (BALANCED)
- b. Riiuli-te-l seis-i-d rea-s purgi-d maasikamoosi.
shelf-PL-ADE stand-PST-3PL row-INE jar-PL.NOM strawberry.jam.PAR
‘On the shelves, jars of strawberry jam stood in rows.’ (Erelt et al. 1993b:144)

In (302), the N1s (*saalitüüed* ‘roomfuls’ and *purgid* ‘jars’) are both plural. Note as well that N2 is plural in (302a), but singular in (302b). Number-marking on N1 is apparently independent of number-marking on N2. We could interpret these facts in one of two ways. If we treat number as a feature of nouns, then this would simply be another similarity between N1 and N2: both have number features. Alternatively, if we follow Ritter 1991 and subsequent work (as I have

⁴I have had some difficulty eliciting similar examples from speakers, but the ones given here have been accepted and judged to be normal. Erelt et al. (1993b) also provide some examples, though they note that there is a tendency to avoid non-nominative plural measures and use alternative structures, such as compounds, e.g., *leivaviilud* ‘bread slices’ instead of *viilud leiba* ‘slices of bread’ or other kinds of modifiers, e.g., *ämbrid veega* ‘buckets with water’ instead of *ämbrid vett* ‘buckets of water’. These are the kinds of examples that my speakers typically suggest as alternatives when presented with examples using plural measures. I have no account for this restriction at the moment. See also Hankamer & Mikkelsen (2008) for similar observations in Danish.

done thus far), then number features are not generated on nouns, but on functional heads above nouns (often called Num⁰). The presence of two independent number values is exactly what the binominal analysis predicts, but it must be stipulated under an analysis where N1 is not a normal noun.

A prediction that the lexical analysis of N1 makes is that some amount of recursion should be possible. Since both N1 and N2 are lexical nouns, then we expect that we should at least minimally be able to have a structure where one noun is both “an N1” and “an N2.” Such examples are certainly possible in English (see (303)–(304)).

(303) a truckful of boxes of bottles of different kinds of wine

(304) the number of years of education

Examples are attested in Estonian in the main descriptive grammar (Erelt et al. 1993b).

(305) a. ?? hulk koorma-id heinu
 a.lot.NOM load-PL.PAR hay.PAR
 ‘a lot of loads of hay’ (Erelt et al. 1993b:147)

b. ?? taldriku-täis viile sooja saia
 plate-ful.NOM slice.PL.PAR warm.PAR white.bread.PAR
 ‘a plateful of slices of warm white bread’ (Erelt et al. 1993b:146)

However, consultants do not produce such examples in translation tasks, and I also have not found a consultant who accepts them as normal. The judgments for the examples in (305) do not come from Erelt et al. (1993b), but from my consultants’ intuitions when presented with those examples (and examples like them). The fact that such examples are rejected may be connected to the status of non-nominative plural N1s as noted in footnote 4. Since N2 of a pseudopartitive can never be in nominative case, and must be plural if it is a count noun (something that is true of all possible N1s, as far as I know), then they will always be awkward, and speakers will choose to circumlocute. In grammaticality judgment tasks, my speakers consistently rejected stacked pseudopartitives. As alternatives, they usually offer examples with the second and third nouns forming a compound, as in the following examples:

(306) a. ?? Laua peal on taldriku-täis viile sooja leiba.
 table on be.3 plate-ful slice.PL.PAR warm.PAR rye.bread.PAR
 Intended: ‘There is a plateful of slices of warm rye bread on the table.’

b. Laua peal on taldriku-täis sooje leiva-viile.
 table on be.3 plate-ful warm.PL.PAR rye.bread-slice.PL.PAR

(Speaker volunteered alternative to (306a).)

- (307) a. ?? Maja taga on hulk tükke graniiti.
house.GEN behind be.3 a.lot piece.PL.PAR granite.PAR
Intended: ‘Behind the house are a lot of pieces of granite.’
- b. Maja taga on hulk graniiditükke.
house.GEN behind be.3 a.lot granite.piece.PL.PAR
(Speaker volunteered alternative to (307a).)

Thus, in (306), the compound noun *leivaviile* ‘bread slices’ is preferred to the pseudopartitive *viile (sooja) leiba* ‘slices of (warm) rye bread’. Similarly, in (307), the compound noun *graniiditükke* ‘granite pieces’ is preferred to the pseudopartitive *tükke graniiti* ‘pieces of granite.’

Finally, if N1s are normal nouns, we would expect to see them in isolation (i.e., without an N2 phrase). This is certainly true of container nouns like *kott* ‘bag’ and *purk* ‘jar’. Some particularly interesting cases come from N1s that can be used in another construction, which I call the POSSESSIVE PARTITIVE construction. Some examples are given below:⁵

(308) POSSESSIVE PARTITIVES:

- a. heteroeeenne [asesõna-de] **rühm**
heterogenous pronoun-PL.GEN group
‘a heterogenous group of pronouns’ (Erelt et al. 2000:187)
- b. Mis [selle riide] **meeter** maksa-b?
what this.GEN cloth.GEN meter cost-3SG
‘What does a meter of this cloth cost?’ (EKSS, entry for *meeter*)
- c. Autoratas-te alt paisku-s [sulalume] **kämpe**.
car.wheel-PL.GEN from.under burst-PST.3SG melting.snow.GEN clod.PL.PAR
‘Clods of melting snow burst from under the car wheels.’
(EKSS, entry for *kämp*)

⁵Note that these possessive partitives cannot be rendered in English using possessives:

- (i) * a heterogenous pronouns’ group
(ii) * this fabric’s meter
(iii) * melting snow’s clods

Similar facts were noted by Barker (1995), who proposed a semantics for the possessive construction that would not allow the possessor to be a ‘part’ and the possessum be the ‘whole’. Such relations are typically rendered as *of*-complements in English, as in the translations for (308).

- b. enamiku-l [nende-l juhtu-de-l]
 majority-ADE DEM.PL-ADE situation-PL-ADE
 ‘in a majority of these situations’ (PARLIAMENT)

(301) Possessors:

- a. enamik [kooli-de direktoreid]
 majority school-PL.GEN director.PL.PAR
 ‘a majority of school directors’ (PARLIAMENT)

- b. osa [väikesaar-te elanikke]
 some small.island-PL.GEN inhabitant.PL.PAR
 ‘some small island inhabitants’ (PARLIAMENT)

It is generally believed that demonstratives are merged quite high within DP— in chapter 2, I proposed that they are merged as specifiers of DP, following Harizanov 2011, Kramer 2009. The fact that they can surface in the N2 phrase would thus require that the N2 phrase can be at least as large as DP. Possessors have been argued to occupy Spec,DP in other languages (see, e.g., Abney 1987, Szabolcsi 1983), but as we saw in chapter 2, there are lower possessor positions in Estonian.

Second, the N2 phrase can be pronominal. Erelt et al. (2000) state that personal pronouns are excluded from pseudopartitives, but they can be used in partitive constructions with elative case, as in (310).

- (310) Enamik mei-st on lõpeta-nud Tartu ülikooli.
 majority 1PL-ELA be.3 finish-PST.PCPL T.GEN university.ACC
 ‘A majority of us have finished our studies at Tartu University.’
 (Erelt et al. 2000:552)

It does indeed appear to be true that personal pronouns are excluded from the N2 phrase. For example, a version of (310) with partitive case instead of elative case was rejected by all of my consultants.

- (311) * Enamik mei-d on lõpeta-nud Tartu ülikooli.
 majority 1PL-PAR be.3 finish-PST.PCPL T.GEN university.ACC
 Intended: ‘A majority of us have finished our studies at Tartu University.’

However, third-person pronouns and names seem to be marginally possible.

- (312) osa Euroopa-t
 part Europe-PAR
 ‘part of Europe’ (Tamm 2011:29)

(313) Pronouns in pseudopartitives:

- a. Anna veel üks suutäis seda.
give.IMP.2SG more 1.NOM mouthful.NOM this.SG.PAR
'Give (him) one more mouthful of this.' (BALANCED)
- b. päris suur hulk neid, kes tööta-vad ka kohalike-s volikogu-de-s
quite big bunch these.PL.PAR who work-3PL also local.PL-INE council-PL-INE
'a quite big bunch of those who also work in local councils' (PARLIAMENT)

Example (312) has a name N2. The examples in (313) show demonstrative pronouns as N2s, although some caveats are necessary. The inanimate pronouns in Estonian are synonymous with the demonstrative (singular *see*, plural *need*). I have glossed them as demonstratives above, but I leave as an open question whether the two can be collapsed syntactically. Furthermore, for plural pronouns, the inanimate and animate forms are only distinguished in nominative case (*nemad/nad* for animates, *need* otherwise). Since the N2 phrase in a pseudopartitive can never be in nominative case, it is not possible to know for sure whether we are dealing with a demonstrative (pronoun) or a pronoun that lives only one life.

The third argument for treating N2 phrases as large nominal extended projections is that they can receive definite interpretations in pseudopartitives. In Tamm's (2011) investigation of the semantics of the partitive and pseudopartitive constructions in Estonian, she gives the following as examples of N2 phrases allowing a definite interpretation:

(312) osa Euroopa-t
part Europe-PAR
'part of Europe'

(314) liiter veini
liter wine.PAR
'a liter of wine' or 'a liter of the wine'

These three observations together provide strong support for the kind of structure I proposed in (309), where the N2 phrase is (or can be) quite large. I propose that it can be at least as large as a DP. I say "can be," because crosslinguistic research on pseudopartitives has revealed much variation, in particular with respect to the size of the N2 phrase across languages or even within one language. Perhaps new diagnostics will come to light in future research that point to the existence of two pseudopartitive structures in Estonian: one in which the N2 phrase is a DP, and one in which the N2 phrase is something smaller (NumP or NP), with both structures

coexisting (and some surface forms being structurally ambiguous). The focus of this chapter is on the case-marking seen in pseudopartitives, and I have yet to find any case-based reason to distinguish two sizes of pseudopartitives. If it turns out to be the case that Estonian has two pseudopartitive structures, this result will not affect my analysis, as the analysis I will ultimately propose does not crucially depend on the size of the N2 phrase.

4.3 Case-marking in Estonian pseudopartitives

The goal of this chapter is to analyze the case-marking possibilities in Estonian pseudopartitives. I will show that there are two possible case-marking patterns. In the PARTITIVE PATTERN, the N2 phrase is marked with partitive case. In the MATCHING PATTERN, the N2 phrase's case-marking matches the case-marking on N1.

(315) Partitive pattern:

- a. enamik inimesi
majority people.PL.PAR
'a majority of people'
- b. tükk leiba
piece bread.PAR
'a piece of bread'

(316) Matching pattern:

- a. Enamiku-l inimes-te-l pole selle-ks raha.
majority-ADE person-PL-ADE NEG.be this-TRL money.PAR
'A majority of people do not have money for this.' (PARLIAMENT)
- b. tüki-le leiva-le
piece-ALL bread-ALL
'onto a piece of bread'

What I will show in this section is that the partitive pattern and the matching pattern are mutually exclusive. This is not immediately apparent when looking at pseudopartitives in the full case paradigm of Estonian. This is given in Table 4.1.

I will argue that the appearance of the partitive pattern and the matching pattern can be linked directly to the case-marking on N1 (and thus, to the case value assigned to the entire pseudopartitive). More concretely, I will propose that the matching pattern is limited to lexical/inherent cases in Estonian; other cases (nominative and accusative) show the partitive pat-

<i>NI Case</i>	<i>Singular</i>	<i>Pattern</i>	<i>Translation</i>
NOMINATIVE	tükk leiba	PARTITIVE	‘a piece of bread’
GENITIVE	tüki leiba /	PARTITIVE	‘of a piece of bread’
	tüki leiva	MATCHING	‘of a piece of bread’
PARTITIVE	tükki leiba	(<i>can’t tell</i>)	‘a piece of bread’
ILLATIVE	tüki-sse leiva-sse	MATCHING	‘into a piece of bread’
INESSIVE	tüki-s leiva-s	MATCHING	‘in a piece of bread’
ELATIVE	tüki-st leiva-st	MATCHING	‘out of a piece of bread’
ALLATIVE	tüki-le leiva-le	MATCHING	‘onto a piece of bread’
ADESSIVE	tüki-l leiva-l	MATCHING	‘on a piece of bread’
ABLATIVE	tüki-lt leiva-lt	MATCHING	‘off of a piece of bread’
TRANSLATIVE	tüki-ks leiva-ks	MATCHING	‘for/into a piece of bread’
TERMINATIVE	tüki leiva-ni	SUSPENDED	‘until a piece of bread’
ESSIVE	tüki leiva-na	SUSPENDED	‘as a piece of bread’
ABESSIVE	tüki leiva-ta	SUSPENDED	‘without a piece of bread’
COMITATIVE	tüki leiva-ga	SUSPENDED	‘with a piece of bread’

Table 4.1: Case patterns for the pseudopartitive *tükk leiba* ‘piece of bread’

tern. Before we get there, there are some aspects of the Estonian case system that we must clarify.

There are two obstacles that must be addressed before my claim (that there are two case patterns— partitive and matching— and they are mutually exclusive) can go through. First, note that both patterns are possible when the N1 bears genitive case. On the surface, this appears to suggest that the matching and partitive patterns are not mutually exclusive. In what follows, I will argue that morphological genitive in Estonian is in fact the exponent of two syntactic cases: true genitive, which shows the matching pattern, and a covert accusative, which shows the partitive pattern.

The second obstacle concerns the last four cases— terminative, essive, abessive, and comitative— which do not show either pattern. Instead, N1 bears genitive case and N2 bears the case-marker itself (e.g., the comitative *-ga*). This is a pattern that I have termed SUSPENDED in Table 4.1. I will show that this marking pattern is predicted if we adopt an analysis whereby the last four cases are not cases at all, but rather involve clitic (i.e., morphophonologically dependent) postpositions. Since postpositions normally assign genitive case to their complements, this change will collapse the last four cases with the true genitive.

Before eliminating these two obstacles, I would like to briefly discuss existing theoretical approaches to partitive case. Most of the discussion has centered on uses of partitive case different from the one discussed here.

4.3.1 The many lives of partitive case

The partitive case in Estonian serves many purposes outside of pseudopartitive constructions. Perhaps most famously, objects of transitive verbs are often marked with partitive case.

- (317) a. Heiko loe-b raamatu-t.
 H.NOM read-PST.3SG book-PAR
 ‘Heiko is reading a book.’
- b. Heiko loe-b raamatu-id.
 H.NOM read-PST.3SG book-PL.PAR
 ‘Heiko is reading some books.’

In the above examples, the object of *lugema* ‘read’ is bearing partitive case. Partitive case is not the only case-marking possibility for transitive objects. When the conditions are right (to be made more precise momentarily), singular transitive objects apparently bear genitive case and plural transitive objects bear nominative case.

- (318) a. Heiko luge-s raamatu läbi.
 H.NOM read-PST.3SG book.GEN through
 ‘Heiko read a/the book (and he finished it).’
- b. Heiko luge-s raamatu-d läbi.
 H.NOM read-PST.3SG book-PL.NOM through
 ‘Heiko read the books (and finished them).’

In addition to these distinctions in object-marking, partitive case can be found on subjects of some intransitives (roughly the class of unaccusatives), all objects under negation, objects of some adpositions, subjects of *consider*-type small clauses, and phrases that I call DIMENSIONAL MODIFIERS⁶ (among possibly others). I mention these here for the sake of completeness. I will not attempt to give a unified characterization of partitive case in Estonian— the focus of this

⁶Dimensional modifier is the name that I give to phrases like the following:

- (i) [kollas-t värvi] maja
 yellow-PAR color.PAR house.NOM
 ‘a yellow (in color) house’

chapter is to explore the case-marking patterns in Estonian pseudopartitives, and partitive case is one of the pieces.

Among the uses of partitive case listed above, it is object-marking that has gotten the most attention in the literature— specifically, object-marking in Finnish. The alternations between partitive and non-partitive appear to have a similar core in Finnish and Estonian, though they are not identical. I would like to briefly discuss the kinds of analyses that have been proposed for partitive case as a backdrop for the assumptions about partitive case that I will ultimately adopt.

The earliest theoretical discussion of partitive that I know of is Belletti’s (1988) analysis of definiteness effects. In this paper, Belletti proposes that partitive is an inherent Case assigned to indefinite internal arguments of unaccusative verbs. The paper is largely not about Finnish, though, and as Vainikka & Maling (1996) convincingly show, the distribution for Belletti’s “partitive” is different in crucial ways from the Finnish partitive case. They adopt the view that the Finnish partitive is structural Case assigned to objects, and that appears to have become the predominant view. Kiparsky (1998) notes that the Finnish partitive is a case on the border between structural and inherent cases, ultimately proposing an analysis that is “in the spirit of” this distinction. The most modern treatment comes from Csirmaz (2012), who argues that partitive is essentially structural as well. In Csirmaz’s account, “partitive” is one possible spell-out of a structurally assigned [CASE] feature. The conditions governing whether this feature is spelled out as partitive are defined in mostly semantic terms, thus Csirmaz’s account is similar in spirit to Kiparsky’s— partitive case is closely linked to both syntax and semantics. We cannot forget, though, that these analyses are largely based on alternations in argument-marking— though Csirmaz ultimately discusses partitive marking in quantificational constructions, the patterns are not deeply investigated.

Brattico (2010) discusses the partitive case assigned in Finnish numeral-noun constructions in great detail, ultimately settling on an analysis where the numeral itself assigns case to its complement. Brattico does not discuss the question of whether this partitive is structural or

-
- (ii) [pikka kasvu] tüdruku-d
tall.PAR growth.PAR girl-PL.NOM
'tall (in stature) girls'

They are nominal phrases describing some quality of the noun. I assume they are PP modifiers, but I will not investigate them in detail here.

inherent, but the proposed analysis seems more like a structural case than an inherent case, since it is *all* numerals that assign partitive, and not an idiosyncratic subclass of numerals. However, it also seems inherent in the sense that it is assigned by a head directly to its complement. The modern conception of structural cases (thinking here of nominative and accusative) often do not involve a head-complement relation. In the Chomskyan view, nominative and accusative are assigned by a functional head to a DP argument in their c-command domain. In the Marantzian view as updated most recently by Preminger (2011), accusative is assigned to a caseless DP that is c-commanded by another caseless DP, and any DP that does not receive a case value during the course of a derivation ends up with nominative case. Neither of these configurations matches up perfectly with the partitive case assigned in Estonian pseudopartitives. Despite this, I will tentatively assume that partitive case in Estonian pseudopartitives is structural, but all that is crucial is that partitive case in Estonian pseudopartitive is not inherent Case.

Against this backdrop, I will now turn to a more critical discussion of object-marking in Estonian. We will see that the behavior of pseudopartitives in object position elucidates an aspect of the Estonian case system in a unique way.

4.3.2 Accusative in Estonian grammar

There is a distinction made in Finnic linguistics between “total objects” and “partial objects.” The distribution is affected by many factors— see Tamm 2007 for a thorough discussion of the alternation in Estonian. We will simplify things here, as what is relevant for us is simply that there is a distinction. The alternation is connected to nominal semantics on one hand and verbal semantics on the other. A partial object is one that is **either** (i) quantitatively indefinite, or (ii) the object of an ongoing (i.e., atelic) action. A total object is an object that is **both** (i) quantitatively definite and (ii) the object of a completed (i.e., telic) action. The distinction manifests in the case-marking of the object. Partial objects are always marked with partitive case. Traditionally, total objects are described as showing a split: singular objects surface in genitive case, but plural objects surface in nominative case. This is summarized in Table 4.2 and some examples are given in (7) and (6).

(7) Total objects:

- a. Heiko luge-s raamatu läbi.
H.NOM read-PST.3SG book.GEN through

	<i>Total</i>	<i>Partial</i>
<i>Singular</i>	GEN	PAR
<i>Plural</i>	NOM	PAR

Table 4.2: Morphological case of transitive objects in Estonian

‘Heiko read a/the book (and he finished it).’

- b. Heiko luge-s raamatu-d läbi.
 H.NOM read-PST.3SG book-PL,NOM through
 ‘Heiko read some/the books (and finished them).’

(6) Partial objects:

- a. Heiko luge-s raamatu-t.
 H.NOM read-PST.3SG book-PAR
 ‘Heiko was reading a book.’
- b. Heiko luge-s raamatu-id.
 H.NOM read-PST.3SG book-PL,PAR
 ‘Heiko was reading some books.’

This section will be devoted to an exploration of the marking of total objects. The glosses in the examples in (7) are unquestionably morphologically accurate: *raamatu* ‘book.GEN’ is the genitive singular form of *raamat*, and *raamatu-d* is the proper nominative plural form. There are no distinct word forms in Estonian that can be identified as the more familiar case for objects, ACCUSATIVE.

However, this is not true for some of Estonian’s close genetic relatives. From a morphological perspective, an accusative can be identified for Finnish, but it is only weakly present. The structural cases in Finnish (following Kiparsky (2001)) are given in Table 4.3. Note that nouns

	‘bear’		‘he, they’	
	Singular	Plural	Singular	Plural
Nominative	karhu	karhu-t	hän	he
Accusative	karhu, karhu-n	karhu-t	häne-t	he-i-dä-t
Genitive	karhu-n	karhu-j-en	häne-n	he-i-dä-n
Partitive	karhu-a	karhu-j-a	hän-tä	he-i-tä

Table 4.3: Finnish structural cases (Kiparsky 2001)

do not have a distinct accusative form in Finnish. For singular nouns, the so-called \emptyset -accusative

is identical to the nominative, and the so-called *n*-accusative is identical to the genitive. The choice between the \emptyset -accusative and the *n*-accusative is traditionally described as being governed by JAHNSSON’S RULE:

(319) JAHNSSON’S RULE (informal): Verbs which have no overt subjects govern the \emptyset -accusative; verbs with overt subjects govern the *n*-accusative (Kiparsky 2001:317).

Many linguists now view the \emptyset -accusative simply as a nominative (see references in Kiparsky 2001). In contrast to common nouns, pronouns do have a distinct accusative form, marked by *-t*. Note that the pronoun’s accusative form is used even when the proper form for a common noun would be the \emptyset -accusative. Some examples are provided in (320).

- (320) a. Anna Mati-n näh-dä karhu / sinu-t!
 let.IMP M-GEN see-INF bear-ACC / you-ACC
 ‘Let Matti see the(/a) bear / you!’ (Kiparsky 2001:317)
- b. Matti anta-a häne-n näh-dä karhu-n / sinu-t.
 M.NOM let-3SG him-GEN see-INF bear-ACC / you-ACC
 ‘Matty will let him see the(/a) bear / you.’ (Kiparsky 2001:317)

In (320a), the common noun *karhu* is in the form traditionally described as the \emptyset -accusative. Kiparsky (2001) glosses it as nominative, following many others. In (320b), it is in the *n*-accusative form, which is identical to the genitive. Note, however, that the pronoun is in the distinct accusative form in both examples. I will not discuss the details of Kiparsky’s (or any other’s) analysis of the Finnish structural case system— it suffices to note that the language has a morphological form corresponding to traditional accusative case.

Moving further north, Skolt Saami has an accusative, even for nouns. Note here that the

	Singular	Plural
Nominative	čüäcc	čüäčč
Accusative	čüäčč	čüäčč-a-i-d
Genitive	čüäčč	čüäčč-a-i

Table 4.4: Abbreviated case paradigm for Skolt Saami *čüäcc* ‘rotten snag’ (Feist 2010:140)

accusative singular is syncretic with the genitive singular, as in Estonian and Finnish. In contrast to Estonian and Finnish, the accusative plural in Skolt Saami is distinct from the nominative plural. In this way, Skolt Saami breaks rank. Just as with Finnish, the forms glossed here as accusative appear where we expect to see accusatives: e.g., objects of transitive verbs:

- (321) piõgg muõrid da čää'õõ liikktâäll
 wind.SG.NOM tree.PL.ACC and water.SG.ACC move.PRS.3SG
 'The wind moves the trees and the water' (Feist 2010:232)

There are thus good reasons for proposing an accusative case from a genealogical perspective.

If Estonian had an accusative case, this would be the case that is assigned to total objects, and possibly only total objects if it is anything like the Finnish accusative. However, Estonian accusative would be purely syntactic— its actual morphological realization would be genitive in some instances and nominative in others.

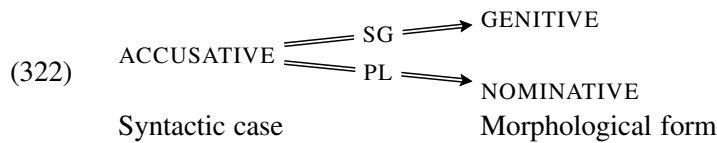

In fact, this is the position endorsed by Caha (2009), Hiietam (2003) and Tamm (2007).⁷ Hiietam gives a number of arguments for treating direct object genitives and direct object nominatives as distinct from true genitives and nominatives.⁸ I will not review her arguments here— they are certainly suggestive of a distinction, but I believe they are compatible with either an accusative analysis of Estonian objects or one that does not make use of an accusative. Instead, I want to provide what I believe is a novel argument from pseudopartitives in favor of treating direct object genitive as distinct from true genitives. The examples are not new, but their relevance for the accusative hypothesis has not been discussed, so far as I know. First, note that pseudopartitives in the position of true genitives (i.e., possessors or objects of adpositions) show the matching pattern: both N1 and the N2 phrase are in genitive case:

- (323) Pseudopartitives as objects of adpositions show the matching pattern:
- a. Putukas roomas ümber klaasi vee / *vett.
 bug.NOM crawl-PST.3SG around glass.GEN water.GEN / water.PAR
 'A/the bug crawled around a/the glass of water.'
 - b. Kui palju sa koti kartuli-te / *kartule-id eest
 how much you.NOM bag.GEN potato-PL.GEN / potato-PL.PAR for
 mak-si-d?
 pay-PST-2SG
 'How much did you pay for the bag of potatoes?' (Erelt et al. 1993b:145)

⁷Tamm calls the case TOTAL CASE (for 'total object' case), but she still crucially distinguishes it from genitive/nominative in the language.

⁸See Miljan 2008 for a rebuttal.

(324) Pseudopartitives as possessors show the matching pattern:

- a. Kolmandiku tordi / *torti hind oli kaks rubla.
 third.GEN tart.GEN / tart.PAR price.NOM be.PST.3SG two.NOM ruble.PAR
 ‘The price of a third of a tart was two rubles.’ (Erelt et al. 1993b:145)
- b. enamiku inimes-te / *inimesi soov
 majority.GEN people-PL.GEN / people.PL.PAR wish.NOM
 ‘[the majority of people]’s wish’ (Erelt et al. 1993b:142)

In both circumstances, the N2 phrase must be genitive. This is true whether N2 is singular, as in (323a) and (324a), or plural, as in (323b) and (324b). Genitive case-marking in pseudopartitives behaves uniformly across these two common contexts for genitive case in Estonian: it always results in the matching pattern. The null hypothesis for direct object genitives is that they will show the matching pattern.

This hypothesis is not borne out. When a pseudopartitive is assigned “genitive” in direct object position N1 still bears genitive case, but the N2 phrase cannot. Instead, it must be partitive.

(325) Pseudopartitives as total objects show the partitive pattern:

- a. Juku suusata-s tüki maa-d / *maa.
 J.NOM ski-PST.3SG piece.GEN land-PAR / land.GEN
 ‘Juku skied a piece of land (i.e., an unspecified distance)’ (Erelt et al. 1993b:142)
- b. Tõi-n koti kartule-id / *kartuli-te.
 bring.PST-1SG bag.GEN potato-PL.PAR / potato-PL.GEN
 ‘I brought a bag of potatoes.’ (Erelt et al. 1993b:145)

Thus, whether the N2 is singular as in (325a) or plural as in (325b), it must be marked with partitive case. When the genitive of total objects is assigned to pseudopartitives, they show the partitive pattern. This is different from genitives assigned to possessors and genitive assigned by adpositions. The existence of this split suggests that not all genitives have the same status in the language— there is something special about the total object genitive case that sets it apart from other instances of genitive. This generalization must be encoded in the grammar someplace. I propose that it be captured in the syntax by adopting the accusative analysis. To be concrete, the case assigned to total objects is not genitive/nominative, but a (covert) accusative. The examples from (325) are thus more properly glossed as follows:

- (325) a. Juku suusata-s tüki maa-d.
 J.NOM ski-PST.3SG piece.ACC land-PAR
 ‘Juku skiied a piece of land (i.e., an unspecified distance)’ (Erelt et al. 1993b:142)
- b. Tõi-n koti kartule-id.
 bring.PST-1SG bag.ACC potato-PL.PAR
 ‘I brought a bag of potatoes.’ (Erelt et al. 1993b:145)

If we split “genitive” case into two versions, accusative (=genitive assigned to total objects) and regular genitive (GEN), then the cases in Estonian fall into three clear groups with respect to case marking patterns in pseudopartitives, visible in Table 4.5. I have listed the partitive examples in both the matching group and the partitive group, because either would be empirically correct.

PARTITIVE PATTERN GROUP		
<i>Case</i>		<i>Pattern</i>
NOM	tükk leiba	PARTITIVE
ACC	tüki leiba	PARTITIVE
PAR	tükki leiba	PARTITIVE

MATCHING PATTERN GROUP		
<i>Case</i>		<i>Pattern</i>
GEN	tüki leiva	MATCHING
PAR	tükki leiba	MATCHING
ILL	tüki-sse leiva-sse	MATCHING
INE	tüki-s leiva-s	MATCHING
ELA	tüki-st leiva-st	MATCHING
ALL	tüki-le leiva-le	MATCHING
ADE	tüki-l leiva-l	MATCHING
ABL	tüki-lt leiva-lt	MATCHING
TRL	tüki-ks leiva-ks	MATCHING

SUSPENDED PATTERN GROUP		
<i>Case</i>		<i>Pattern</i>
TER	tüki leiva-ni	SUSPENDED
ESS	tüki leiva-na	SUSPENDED
ABE	tüki leiva-ta	SUSPENDED
COM	tüki leiva-ga	SUSPENDED

Table 4.5: Case patterns in Estonian pseudopartitives, to be revised again

Making this move allows us the possibility of treating the distribution of the matching pattern and the partitive pattern as truly being about the properties of individual cases. Otherwise, we cannot properly state the generalization without reference to both (i) the particular case, and (ii) its syntactic function.

4.3.3 Some Estonian cases are postpositions

The last wrinkle that we must deal with concerns the SUSPENDED PATTERN GROUP: terminative, essive, abessive, and comitative. These cases are typically written last in traditional case paradigms, and they are commonly called the LAST FOUR CASES. I will adopt this terminology for convenience. In pseudopartitives, they all show a pattern that is distinct from the matching pattern and the partitive pattern. Some examples are below.

(326) Oli-me taas **tüki** **leiva-ta**.
 be.PST-1PL again piece.GEN bread-ABE
 ‘We were once again without a piece of bread.’ (Erelt et al. 1993b:145)

(327) Õpetaja läks **rühma** **õpilas-te-ga** muuseumi.
 teacher go.PST.3SG group.GEN student-PL-COM museum.ILL
 ‘The teacher went to the museum with a group of students.’ (Erelt et al. 1993b:145)

What we see with the last four cases is that N2 bears the special case marker (abessive *-ta* in (326) and comitative *-ga* in (327)). N1 bears what looks like genitive case— and we will ultimately see that this really is genitive case. In the matching pattern, both N1 and N2 bear the same case-marking. Under the tentative assumption that the last four cases are cases, these examples clearly do not show the matching pattern, because the case-marking on N1 is distinct from the case-marking on N2. These examples also clearly do not show the partitive pattern, since partitive case is nowhere to be found. They appear to show a unique pattern, which I have thus far called the SUSPENDED PATTERN.

The suspended pattern exhibited by pseudopartitives marked by the last four cases is actually visible outside of pseudopartitives. In fact, this suspended marking pattern is visible even in a normal DP:

(328) noore(*-na) ajakirjaniku-na
 young.GEN journalist-ESS
 ‘as a young journalist’

- (329) nende(*-ga) suur-te(*-ga) hoone-te-ga
 these.PL.GEN big-PL.GEN building-PL-COM
 ‘with these big buildings’

The marking seen in the above examples is identical to the marking seen in pseudopartitives. The last word in the DP bears the case marker, and any preceding modifiers showing concord surface in genitive case. So, the peculiar marking seen in (326) and (327) is not localized to pseudopartitives— it is a general fact about the last four cases in Estonian. The explanation I will adopt for this peculiar aspect of the last four cases is once again a departure from traditional descriptions: I propose that the last four cases are not “cases” at all, but phonologically dependent postpositions that assign genitive case to their complements. Because most morphological case forms are based on a stem that is identical to the genitive anyway, the end result is that these suffixes look like case forms of the word they attach to. I will call this the *POSTPOSITION* analysis, as opposed to the traditional *CASE* analysis.

There is a conspiracy in Estonian that makes it difficult to distinguish between the postposition analysis and the case analysis. First, let me note that genitive is the most common case assigned by postpositions in Estonian. Ehala (1994) conducted a corpus study of the usage of adpositions in 1905, 1972, and 1992. From that sample about 98% of postpositional usages have a genitive complement (Ehala 1994). Some examples are given below.

- (330) Kardina-d on [akna ees].
 curtain-PL.NOM be window.GEN front
 ‘The curtains are in front of the window.’ (EKSS, entry for *ees*)
- (331) mehe kohta
 man.GEN about
 ‘about a man’ (EKSS, entry for *kohta*)
- (332) Hakka-si-n [artikli jaoks] materjali kogu-ma.
 start-PST-1SG article.GEN for stuff.PAR collect-MA
 ‘I started to collect stuff for the article.’ (EKSS, entry for *jaoks*)

Though prepositions are not dominated by genitive marking in the same way, the figures Ehala (1994) provides still show that genitive is the most common among usages, at 38.4%, with partitive case second at 29.3% (see Figure 2, p. 181). It is normal for adpositions to assign genitive case in Estonian.

This fact becomes relevant when viewed in light of the morphological decomposition of cases in Estonian. With the exception of the nominative and partitive, cases in Estonian are

based on what looks like a genitive stem (see Table 4.6). This is true for the last four cases, but

stem	ending	case	translation
<i>tigu</i>		nominative	‘snail’
<i>teo</i>		genitive	‘snail’s’
<i>teo</i>	<i>-le</i>	allative	‘(on)to a snail’
<i>teo</i>	<i>-ga</i>	comitative	‘with a snail’
<i>laud</i>		nominative	‘table’
<i>laua</i>		genitive	‘table’s’
<i>laua</i>	<i>-le</i>	allative	‘(on)to a table’
<i>laua</i>	<i>-ga</i>	comitative	‘with a table’

Table 4.6: Case morphology in Estonian

it is also true for the other seven “semantic cases” in the language: illative, inessive, allative, ablative, adessive, allative, and translative.

What this means is that, if the last four cases are cases, then their forms will be based on a genitive stem. If the last four cases are postpositions, they will (most likely) take genitive complements. After they become attached to their hosts, they will look like case markers on a genitive stem. In other words, individual word forms cannot distinguish between the case analysis and the postposition analysis. When we turn our gaze to examples that go beyond individual word forms, there are two facts about the distribution of the last four cases that are immediately explained if they are postpositions but must be stipulated if they are lumped together with the other Estonian cases.

First, recall that the last four cases are only realized on the rightmost element in a DP (which is generally the head noun):

(328) noore(*-na) ajakirjaniku-na
 young.GEN journalist-ESS
 ‘as a young journalist’

(329) nende(*-ga) suur-te(*-ga) hoone-te-ga
 these.PL.GEN big-PL.GEN building-PL-COM
 ‘with these big buildings’

Note that it is indeed morphologically possible for adjectives and demonstratives to host the comitative marker whenever they are the rightmost element inside a DP (and identical observations could be made about the terminative *-ni*, essive *-na*, and abessive *-ta*):

- (333) Sina võta suur nukk ja mina mängi-n väikese-ga.
 you take.IMP.2SG big doll and I play-1SG little.GEN-COM
 ‘You take the big doll and I’ll play with the little one.’
- (334) Ma ole-n selle-ga rahu-l.
 1SG be-1SG this.GEN-COM peace-ADE
 ‘I am happy with this.’

Because there is no overt noun in (333) or (334), *-ga* attaches to whatever happens to be rightmost.

In this respect, the last four cases are just like postpositions and unlike case markers. Postpositions are always adjacent to the rightmost element in the DP, and true cases must be marked on all the modifiers showing concord, as we saw in Chapter 3.

(335) Postpositions appear rightmost:

- a. kollase (*kohta) teo kohta
 yellow.GEN snail.GEN about
 ‘about a/the yellow snail’
- b. suure (*ees) mäe ees
 big.GEN hill.GEN front
 ‘in front of a/the big hill’

(336) Cases appear on all modifiers showing concord:

- a. selle*(-s) suure*(-s) maja-s
 this-INE big-INE house-INE
 ‘in this big house’
- b. nende*(-ks) inimes-te-ks
 these.PL-TRL person-PL-TRL
 ‘for these people’

Treating the last four cases as postpositions thus immediately explains why they only occur once in the DP whereas the other elements appear in genitive case.

Nevis (1986) notes that coordinate structures are another environment where normal cases and postpositions show divergent behavior with respect to marking on the left conjunct. Postpositions can either appear in both conjuncts or only in the right conjunct.

(337) Postpositions:

- a. isa ees ja ema ees
 father.GEN front and mother.GEN front

‘in front of father and in front of mother’

- b. isa ja ema ees
 father.GEN and mother.GEN front
 ‘in front of father and mother’

There is a straightforward explanation for these facts. In (337a), what we see is coordination of full PPs; in (337b), there is a single P⁰ taking a coordinated DP as a complement.

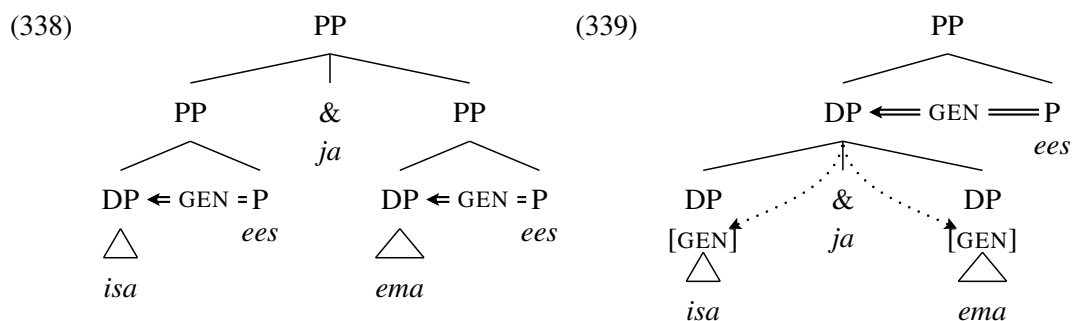

Case concord ensures that the genitive case assigned by the P⁰ in (339) will come to be represented on both conjuncts.

In contrast, normal cases must appear on both conjuncts. This is represented below for the allative *-le*.

- (340) a. isa-le ja ema-le
 father-ALL and mother-ALL
 ‘to father and to mother’
- b. * isa ja ema-le
 father.GEN and mother-ALL
 Intended: ‘to father and mother’

In order to make the comparison as clear as possible, let us adopt Nikanne’s (1993) proposal that the cases of interest here are assigned by phonologically null adpositions. Under these assumptions, the reason that (340b) is ungrammatical is that, regardless of whether the coordinated phrases are PPs or DPs, case concord will ensure that [ALLATIVE] comes to be marked on both conjuncts.

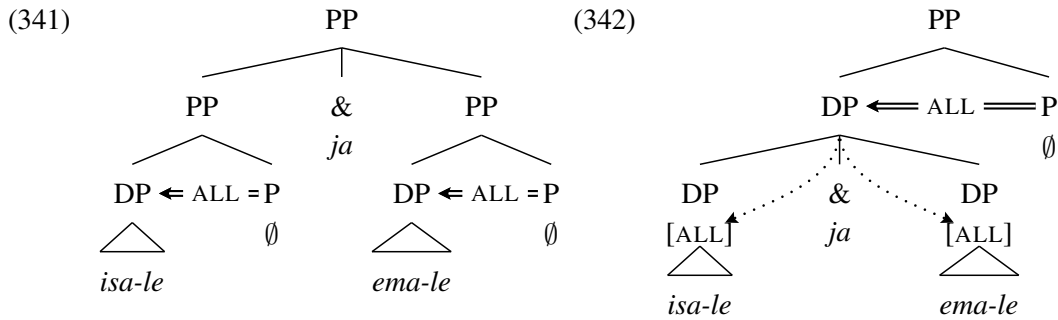

The structures in (341) and (342) parallel those in (338) and (339) syntactically— both DP coordination and PP coordination are ostensibly possible. The differences in (341) and (342) are that (i) the P⁰ head is silent, and (ii) the P⁰ head assigns allative case, not genitive case. The end result is that it is not morphologically possible to determine the difference between the structures in (341) and (342) for the normal cases.

It is known within the traditional literature (Erelt et al. 2000:519) that the last four cases behave like postpositions in coordinate structures— marking on the first conjunct is optional:

(343) jõe(-ni) ja metsa-ni
 river(.GEN)-TER and forest(.GEN)-TER
 ‘as far as the river and the forest’ (Nevis 1986)

(344) maalikunstniku(-ga) ja skulptori-ga
 painter(.GEN)-COM and sculpter(.GEN)-COM
 ‘with a painter and a sculpter’ (Erelt et al. 2000:519)

The endings of the last four cases can be left out of the first conjunct just like with normal postpositions, but unlike true cases.

The facts regarding the last four cases are restated in Table 4.7 below. For the facts con-

	Full Concord	Left Conjunct
true cases	yes	X-case and Y-case
last four cases	no	X(-case) and Y-case
adpositions	no	X (P) and Y P

Table 4.7: Postpositions and case markers in Estonian

sidered here, it seems that the last four cases are more similar to postpositions than they are to true cases. I thus propose that the last four cases are, in fact, postpositions. They assign genitive

case to their complements, and postsyntactically, they attach to the element on their left. For the coordination examples in (343) and (344), we have two structures, just as with postpositions.

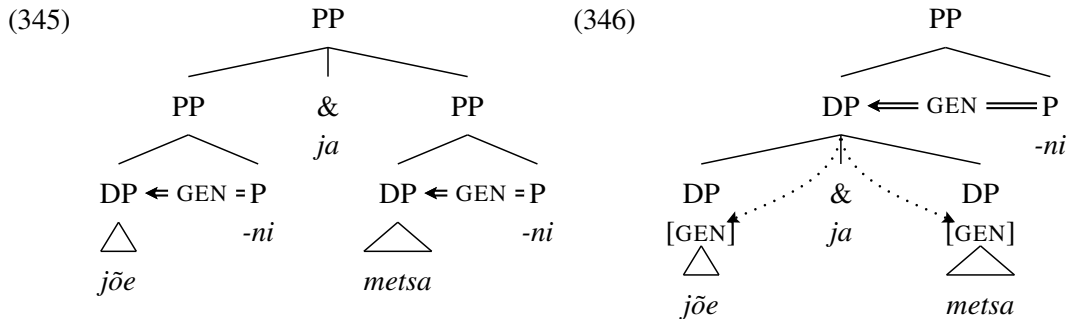

Unlike cases, the P^0 heads in these examples are overt, so the difference between the structures is visible.

4.3.3.1 The last four cases and pseudopartitives

There is one more argument that Nevis (1986) discusses in support of the adpositional analysis of the last four cases. Citing the examples in (347)–(349), he observes that the head of a pseudopartitive (=N1) “cannot be separated from its complement by a postposition or [one of the last four cases]:”⁹

(347) * See on tüki ees leiba
 it be.3 piece.GEN in.front.of bread.PAR
 Intended: ‘It is in front of the piece of bread.’ (Nevis 1986:83)

(348) * See läks tüki-ni leiba.
 it go.PST.3SG piece(.GEN)-TER bread.PAR

⁹Nevis (1986) also provides an example of a pseudopartitive with a normal case-marker on the head, repeated here with his glosses as (i).

(i) See läks tükki leiba.
 it go.PST.3SG piece.ILL bread.PAR
 ‘It went into the piece of bread’ (Nevis 1986:82)

According to Nevis, N1 *tükki* is bearing illative case (the so-called SHORT FORM of the illative) while N2 *leiba* is in partitive case. Thus, what the data in (347)–(349) are supposed to show is another way in which the last four cases are like postpositions and unlike normal case-markers: they cannot come between N1 and N2.

In fact, the form of bread in (i) is ambiguous: the string *leiba* is indeed the partitive singular form of *leib*, but it is also the **short-form illative singular** form of *leib*.

Intended: 'It went up to the piece of bread.' (Nevis 1986:83)

- (349) * See on tüki-ga leiba.
it be.3 piece(.GEN)-COM bread.PAR
Intended: 'It is with the piece of bread.' (Nevis 1986:83)

Indeed, examples like those in (347)–(349) are sharply ungrammatical. Nevis notes that speakers must use alternative structures to express the intended meanings given above. However, the alternative structures he suggests do not include the fully grammatical examples where N1 is marked genitive and N2 bears one of the last four cases:

- (350) See läks tüki leiva-ni.
it go.PST.3SG piece.GEN bread(.GEN)-TER
'It went up to the piece of bread.'

- (351) See on tüki leiva-ga.
it be.3 piece.GEN bread(.GEN)-COM
'It is with the piece of bread.'

When we were still operating under the assumption that the last four cases were true case markers, we referred to this as the suspended pattern: the “case” morpheme is suspended until N2. In light of the postpositional analysis of the last four cases, we can hold that N1 and N2 in fact bear the same case-marking in (350) and (351): genitive. This means that the last four cases show the matching pattern (because N1 and N2 must match in case). Because the last four cases are actually postpositions assigning genitive case to their complements rather than true cases themselves, anything that we say from this point forward about the behavior of genitive case should extend to DPs bearing one of the last four cases as well. The final revision of pattern distributions is shown in Table 4.8. Table 4.8 no longer contains the *SUSPENDED* pattern, which was comprised of the last four cases only. Under the postposition analysis, the last four cases show the matching pattern along with the genitive. In that sense, the *SUSPENDED* pattern is not a truly independent pattern but rather one reflection of a more general pattern.

4.3.4 Interim summary and implications

We have at this point considerably reduced the initial apparent complexity of the patterns of case-marking in Estonian pseudopartitives. There were three patterns (partitive, matching, suspended), and the dividing line between the partitive and matching patterns was not clear, as a

PARTITIVE PATTERN GROUP		
<i>Case</i>		<i>Pattern</i>
NOM	tükk leiba	PARTITIVE
ACC	tüki leiba	PARTITIVE
PAR	tükki leiba	PARTITIVE

MATCHING PATTERN GROUP		
<i>Case</i>		<i>Pattern</i>
GEN	tüki leiva	MATCHING
(TER	tüki leiva-ni	MATCHING)
(ESS	tüki leiva-na	MATCHING)
(ABE	tüki leiva-ta	MATCHING)
(COM	tüki leiva-ga	MATCHING)
PAR	tükki leiba	MATCHING
ILL	tüki-sse leiva-sse	MATCHING
INE	tüki-s leiva-s	MATCHING
ELA	tüki-st leiva-st	MATCHING
ALL	tüki-le leiva-le	MATCHING
ADE	tüki-l leiva-l	MATCHING
ABL	tüki-lt leiva-lt	MATCHING
TRL	tüki-ks leiva-ks	MATCHING

Table 4.8: Case patterns in Estonian pseudopartitives, final version

genitive-marked N1 could lead to both the partitive pattern and the matching pattern. The explanations I proposed for these complexities were both rooted in the relationship between Estonian syntax and morphology. First, the dividing line between the partitive pattern and the matching pattern is clarified if one adopts the view that, notwithstanding the language’s morphology, Estonian has a syntactic accusative case.¹⁰ This syntactic accusative is morphologically identical to genitive for singular nouns. However, it is unlike genitive in that an accusative pseudopartitive shows the partitive pattern, but a genitive pseudopartitive shows the matching pattern.

- (352) a. tüki leiba
 piece.ACC bread.PAR
 ‘a piece of bread (accusative)’
- b. tüki leiva
 piece.GEN bread.GEN
 ‘a piece of bread (genitive)’

¹⁰Again, I am not the first to reach this conclusion. See also Caha 2009, Hiitam 2003, and for a recent dissenting view, Miljan 2008. None of these authors discuss the relevance of the pseudopartitive data presented here for the accusative hypothesis, which are, to my mind, the strongest argument for treating total object “genitives” as distinct from other genitives.

I then sought to reduce the number of case patterns in pseudopartitives through an investigation of “the last four cases” in Estonian. The similarity between postpositions on the one hand and the last four cases on the other is known even in the traditional literature, but the last four cases are nonetheless called cases. I took these similarities seriously, proposing that the last four cases in Estonian are postpositions in the syntax, assigning genitive case to their complements like most postpositions. Making this move illuminates the case pattern generalizations for Estonian pseudopartitives by removing the suspended pattern— those elements showing the suspended pattern are actually showing the matching pattern. What emerges is that the partitive pattern is only seen for nominatives and accusatives— all other cases show the matching pattern.

Traditional grammar (e.g., Erelt et al. (1993b, 2000)) proposes that the Estonian case system has 14 cases. If the conclusions I have reached here are reasonable, then the Estonian case system has 11 cases, not 14— add an accusative and subtract the last four cases. The last four cases (or more properly, the affixal postpositions) are an interesting case study at the frontier between cases and postpositions.¹¹ The approach taken here suggests that both morphological and syntactic evidence are relevant for untangling complex examples on the case-adposition continuum.

Adopting the accusative analysis involves adding a case to the traditional case paradigm, putting Estonian more closely in line with its genetic and geographical neighbors. It also raises interesting questions for the relationship between syntactic case and syncretisms in the morphological case paradigms of a language. This is an issue I will set aside for the moment, but see Caha 2009, 2013 for some recent discussion. With these clarifications, we are ready to train our guns on the alternation between the matching pattern and the partitive pattern.

4.4 Case hierarchies and their sources

I have thus far assumed that the partitive case that sometimes appears in Estonian pseudopartitives is connected in some way to the presence of N1. I take the null hypothesis to be that partitive case is assigned by N1 to its complement.

¹¹See Baker & Kramer (To Appear) for a recent investigation of these issues in Amharic. Baker and Kramer argue that a class of words traditionally called “prepositions” are actually more properly analyzed as case-markers— in a sense, the mirror image of the conclusion that I argue for in Estonian.

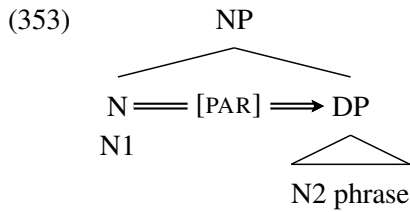

The predominant view on case concord is that this case value is then spread to the elements that DP dominates (and then spreads from those nodes) until there are no more nodes to spread to (i.e., at the bottom of a tree or perhaps at a phase boundary or extended projection boundary). This is represented in (354).

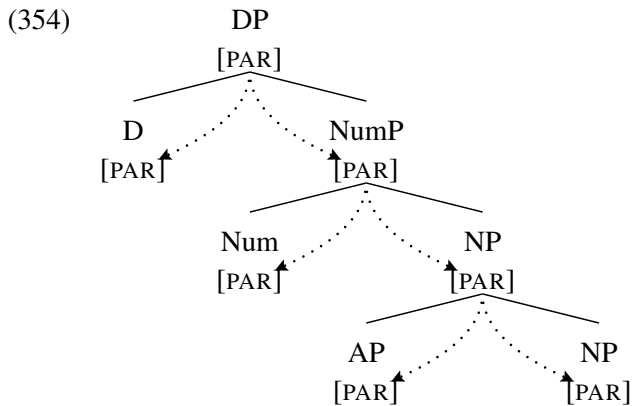

In this way, every element in the N2 phrase comes to bear partitive case.

In the bottom-up model of syntax that I assume, the syntactic environment for this partitive assignment is constructed before the entire pseudopartitive is built. It is thus met before the pseudopartitive is merged with the clausal spine. Given that nominative and accusative have been shown to be dependent on the nominal's position in the clausal spine, the partitive pattern in Estonian pseudopartitives is what we expect: partitive is assigned first, and nominative/accusative are assigned too late to be marked on N2.

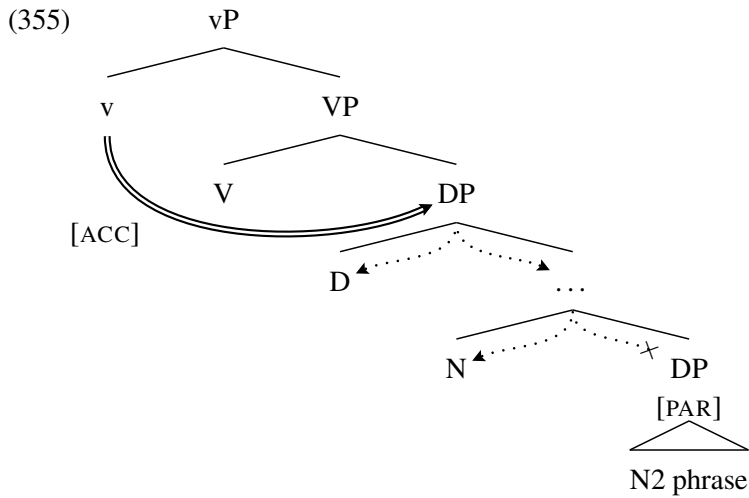

When accusative is assigned to the pseudopartitive in (355), it spreads down the nominal spine until it reaches the N2 phrase. Since that phrase already has a case value (partitive), accusative spreads no further, indicated by the × at the end of the arrow.

Yet this analysis has nothing to say about the matching pattern. Like nominative and accusative, the syntactic elements involved in the assignment of the matching cases are not merged until after partitive case has been assigned by N1. Let us assume for the moment that these cases come from inherent-valued K^0 -heads (Bittner & Hale 1996), which are themselves perhaps encased in a PP shell, as argued by Nikanne (1993) for Finnish.

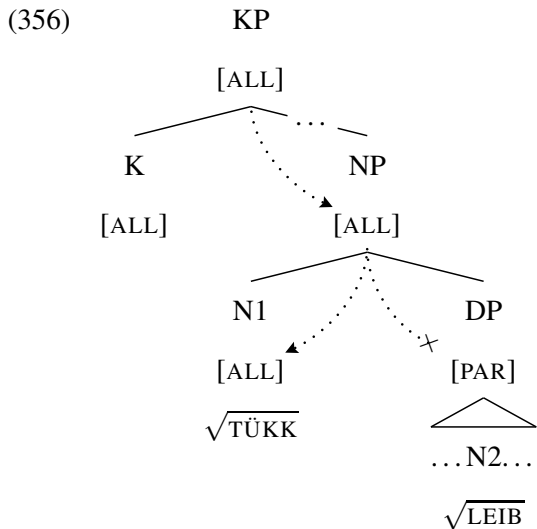

As before, case concord ensures that everything above the N2 phrase (*modulo* elements that do not inflect for case) will bear the appropriate case. However, if we simply port our assumptions

for the accusative in (355), then we predict spreading will stop at DP, as represented in (356). Thus, the simple analysis sketched here, where N1 assigns partitive and case is unable to spread to elements that already have a case value, needs to be revised.

Babby (1984, 1987) investigates similar cases in Russian— examples where one element is in a position to receive more than one case value. This happens perhaps most famously in numeral-noun constructions in Russian. To take one example, the numeral *pjat* ‘five’ assigns genitive case to the noun. However, if the entire NNC is assigned instrumental, then the noun cannot bear genitive.

(357) Russian:

- a. *pjat* *butylok*
 five.NOM bottles.GEN.PL
 (Babby 1987:92)
- b. *pjat*’*ju* *butylkami*
 five.INSTR bottles.INSTR.PL
 (Babby 1987:92)
- c. * *pjat*’*ju* *butylok*
 five.INSTR bottles.GEN.PL
 (Babby 1987:92)

The noun ‘bottles’ in (357b) and (357c) is within the domain of two case assigning strategies. Babby terms such scenarios “case conflicts,” and he ultimately argues that case conflicts are regulated by hierarchies. In a case conflict, the case that is realized morphologically is the one that is ranked higher. Thus, a case hierarchy for Estonian would look like the following:

(358) Estonian case hierarchy:

MATCHING CASES >> PARTITIVE >> NOMINATIVE, ACCUSATIVE

Under the analysis of case concord proposed here, we could think of this in the following way. When a case value would spread to a node that already has a case value, there is a case conflict, and the outcome is regulated by the case hierarchy. Whichever value is higher on the hierarchy becomes the new case value on that node. If overwriting occurs, then spreading continues. If it does not, then spreading stops. Because the matching cases outrank partitive, partitive-marking on the N2 phrase gets fully overwritten by matching cases.

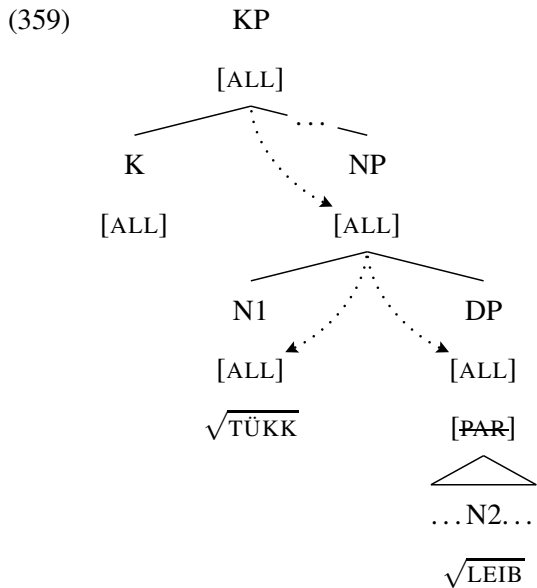

In contrast, the accusative structure in (355) can be preserved as is— accusative does not overwrite partitive, because partitive outranks accusative.

Though the hierarchical analysis can derive the facts, the core formal device that allows the facts to be captured—the hierarchy—is stipulated. It does not provide a deeper understanding of why the hierarchy looks as it does in (358). It is just as easy to stipulate a hierarchy like that in (360) or (361), yet that is not what we see.

(360) Estonian' case hierarchy:

LOCAL CASES, TRANSLATIVE, ACCUSATIVE ≫ PARTITIVE ≫ NOMINATIVE, GENITIVE

(361) Estonian'' case hierarchy:

NOMINATIVE, ACCUSATIVE ≫ PARTITIVE ≫ LOCAL CASES, TRANSLATIVE, GENITIVE

It is particularly puzzling that the hierarchy is not the one given in (361)— why not have nominative and accusative be the only cases triggering the matching pattern?

One might, as Babby (1984, 1987) suggests, propose that the case hierarchy is not an arbitrary ordered list of cases, but is rooted in the well-known distinction between structural and inherent/lexical case. Concretely, Babby proposes that whenever an inherent case and a structural case compete, the inherent case wins.

(362) INHERENT CASE \gg STRUCTURAL CASE

Though this casts the case hierarchy in a familiar light, it still requires a stipulation— somewhere, it has to be stated that such-and-such case is structural. For the kind of simplification presented in (362), the hierarchical facts should follow from independently-necessary facts or proposals concerning the inherent/structural case divide. There have been a number of proposals to this effect, but the existing accounts do not extend cleanly to Estonian pseudopartitives.

4.4.1 Hierarchical effects driven by morphology

One approach to these hierarchical effects is to tie it to the morphology of cases. For example, Brattico (2008, 2010) draws a distinction between cases that “must be overtly realized” and those that do not need to be. His focus is on Numeral-Noun Constructions in Finnish, which display the same case-marking properties as in Estonian:

(363) kolme pien-tä talo-a
three- \emptyset small-PAR house-PAR
'three small houses' (Finnish, adapted from Brattico 2008)

(364) kolme-ssa piene-ssä talo-ssa
three-INE small-INE house-INE
'in three small houses' (Finnish, adapted from Brattico 2008)

Just as in Estonian, a numeral assigns partitive case to its complement in Finnish. However, if the entire DP is assigned some other case, then partitive disappears, and the numeral's complement is marked with the same case as the entire DP. Brattico (2011) ultimately appeals to a hierarchy to account for these facts, but let us take a moment to consider how a hierarchy that is truly driven by case morphology would have to work.

4.4.1.1 Case-stacking

Assume first that syntactic elements can bear more than one case value. When an element has more than one case value, the values are ordered (or structured), such that the second case assigned to an element is stacked outside of the first (see Baker & Vinokurova (2010), Pesetsky (2013)):

(365) Case stacking:
a. **Partitive Assignment:** [bag [potatoes-PAR]]

b. **External Assignment:** P_[TRL] [bag-TRL [potatoes-PAR-TRL]]

In the first step (365a), the N2 phrase is assigned partitive case. When the entire pseudopartitive is merged with another case assigner, e.g., the covert adposition that assigns translative case, this case value is “stacked” on the N2 phrase outside of the previously assigned partitive. Under the stacking analysis we are currently pursuing, these are the representations constructed by the syntax.

When these constructions are interpreted by the morphology, something extra needs to be said, because Estonian words only bear one case marker—in other words, Estonian exhibits no visible case-stacking as in Lardil (Richards 2012) or the examples found in Plank (1995). It is not grammatical, for example, for a word to bear both overt partitive case and some other case, no matter the order.

(366) * mees-t-sse
man-PAR-ILL

(367) * mehe-sse-t
man-ILL-PAR

It follows that abstract representations like those in (365) are not converted into words transparently. More concretely, some of the features in representations like (365b) are not realized morphologically. A separate algorithm must be invoked to dictate which case value is realized. This is the core of the morphological analysis of the alternation between the partitive pattern and the matching pattern.

One such algorithm is proposed by Pesetsky (2013) in his analysis of some case-marking patterns in Russian numeral phrases. In Pesetsky’s system, terminals can be assigned several case values over the course of derivation, but it is only the outermost case value that is realized. I will call this algorithm PRONOUNCE OUTERMOST. This algorithm works perfectly for the matching pattern: cases showing the matching pattern are assigned after partitive and cause apparent overwriting or suppression of partitive case.

(368) PRONOUNCE OUTERMOST predicts the matching pattern:

a. **Partitive Assignment:** [bag [potatoes-PAR]]

b. **External Assignment:** [bag-TRL [potatoes-~~PAR~~-TRL]]

However, PRONOUNCE OUTERMOST makes the wrong predictions for the partitive pattern. For the partitive pattern, partitive is assigned first, and then nominative (or accusative) is

stacked on top of the partitive:

(369) PRONOUNCE OUTERMOST does not predict the partitive pattern:

- a. **Partitive Assignment:** [bag [potatoes-PAR]]
- b. **External Assignment:** [bag-ACC [potatoes-~~PAR~~-ACC]] ❌
- c. **Desired Outcome:** [bag-ACC [potatoes-PAR-~~ACC~~]] ☹️

By PRONOUNCE OUTERMOST, we again expect to find case matching, with accusative case being realized on the N2 phrase, counter to fact. In this environment, partitive case is still realized on the N2 phrase. In order to get the partitive pattern, we must delete the outermost case value (ACC) and pronounce the innermost case value:

(370) The partitive pattern requires pronunciation of the innermost:

- a. **Partitive Assignment:** *kott kartuleid* [bag [potatoes-PAR]]
- b. **External Assignment:** *koti kartuleid* [bag-ACC [potatoes-PAR-~~ACC~~]]

We could call this algorithm PRONOUNCE INNERMOST— this is the sort of algorithm proposed by Baker & Vinokurova (2010) for patterns of case assignment in Sakha. While this successfully predicts the partitive pattern, PRONOUNCE INNERMOST fails to predict the matching pattern:

(371) PRONOUNCE INNERMOST does not predict the matching pattern:

- a. **Partitive Assignment:** [bag [potatoes-PAR]]
- b. **External Assignment:** [bag-TRL [potatoes-PAR-~~TRL~~]] ❌
- c. **Desired Outcome:** [bag-TRL [potatoes-~~PAR~~-TRL]] ☹️

PRONOUNCE INNERMOST cannot account for the matching pattern, because it privileges cases that are assigned earlier, and the order of operations imposed by syntactic-structure building necessitates that partitive will be assigned before the matching cases.

To recapitulate what we have just seen, neither PRONOUNCE OUTERMOST nor PRONOUNCE INNERMOST on their own can account for both the partitive pattern and the matching pattern; each fails where the other succeeds. It seems that the Estonian data requires a more nuanced algorithm.

4.4.1.2 Cases with “overt realization”

One possible source for this nuance is the case morphology itself. Proposals of this sort have been made for numeral-noun constructions in Finnish by Brattico (2008, 2010, 2011) and in Russian by Pesetsky (2013). Recall that Finnish numeral-noun constructions show the same alternation between partitive pattern and matching pattern—the partitive pattern emerges in places where a normal DP would be assigned nominative or accusative. The same is true of numeral-noun constructions in Russian (though the “partitive case” in Russian is genitive). To account for the emergence of the partitive pattern in accusative contexts, Pesetsky suggests that accusative is not actually assigned (pp. 63–66). His algorithm (PRONOUNCE OUTERMOST) would otherwise predict that accusative should surface.¹² More strongly, Brattico proposes that it is only cases “with an overt realization” that trigger the matching pattern. These are not arbitrary stipulations—both are anchored by the fact that the numerals in question have no distinct accusative form. The accusative form of numerals in Finnish and Russian (and, in fact, Estonian) is syncretic with the nominative form. Nominatives arguably do not have overt suffixes in these languages.¹³

However, it is difficult to implement such a proposal with Estonian pseudopartitives, because the nominative and accusative forms of N1 have distinct realizations. We certainly cannot suggest that the pseudopartitive does not receive accusative case (following Pesetsky 2013), as N1 and all of its modifiers are in their accusative forms. For the same reason, we cannot follow Brattico 2010 in assuming that the case-assigner (N1) simply cannot assign case if it itself is bearing case. Once again, accusative-marked N1s are just as capable of assigning partitive case as nominative-marked N1s.

¹²The explanation for appearance of the partitive pattern in nominative contexts is more complex. It is closely tied to the core of Pesetsky’s analysis; it is not possible to discuss nominative without a full discussion of Pesetsky’s analysis, and doing so would take us too far afield. See Pesetsky 2011 for a version of Pesetsky’s (2013) analysis that analyzes nominative and accusative in the same way (as opposed to the different analyses proposed in Pesetsky 2013).

¹³Brattico and Pesetsky stop short of formalizing exactly how the fact that a suffix has no overt realization comes into play. One might propose that the morphology of these languages requires case to be expressed, but precludes case from being realized twice. Then, because nominative (and sometimes accusative) does not have an overt realization, a nominative form “does not count,” permitting the inner partitive to be realized. Exactly how these two pieces are to be formalized is a matter I will not speculate on further, since the “non-zero realization” approach will not work for Estonian in any case.

The behavior of accusative-marked N1s is revealing in light of the morphological properties of the Estonian accusative. Recall that the accusative form for singular nouns (like most N1s) is morphologically identical to genitive case. In the traditional literature, the case I have been calling accusative is called genitive for this very reason. This traditional analysis of Estonian genitives misses a key empirical fact about pseudopartitives, which is that accusative pseudopartitives show the partitive pattern, but genitive pseudopartitives show the matching pattern. Some minimal pairs are given below.

(372) Accusative pseudopartitives:

- a. tüki leiba / *leiva
piece.ACC bread.PAR / bread.ACC
'piece of bread'
- b. klaasi vett / *vee
glass.ACC water.PAR / water.ACC
'glass of water'

(373) Genitive pseudopartitives:

- a. tüki leiva / *leiba
piece.GEN bread.GEN / bread.PAR
'piece of bread'
- b. klaasi vee / *vett
glass.GEN water.GEN / water.PAR
'glass of water'

In the examples above, note that the ungrammatical variants of the examples in each of (372) and (373) are exactly the grammatical variants of the other. In other words, it is not that there is anything wrong morphologically with strings like *klaasi vee* or *tüki leiva*, it is just that they are not well-formed ACCUSATIVE pseudopartitives.

The core of the claim that hierarchical effects arise due to case morphology must be that it has something to do with the morphological form of a particular case. Such an account would have difficulty capturing the difference between Estonian accusative and Estonian genitive. The two cases are morphologically identical for singular nouns, yet they show different case patterns in pseudopartitives. This suggests strongly that the choice between the matching pattern and the partitive pattern is not driven by morphemes *qua* strings of phonological segments, but by the abstract representations that ultimately get spelled out by those strings.

4.4.2 Caha: case hierarchy encoded in syntactic representations

As part of his investigation of the structure of the Classical Armenian case paradigm, Caha (2013) proposes an analysis of some case attraction facts in the language. The examples that he shows are given in (374) and (375).

(374) [bazmowt'-eamb [zawr-**awk**'-n Hay-oc']]
crowd-INS.SG force-INS.PL-DEF Armenian-GEN.PL
'with a crowd of the Armenian forces' (Classical Armenian, Plank 1995, p.43)

(375) Classical Armenian (Plank 1995, p.20)

- a. i knoj-ê t'agawor-i-n
by wife-ABL king-GEN.SG-DEF
'by the wife of the king'
- b. i knoj-ê t'agawor-ê-n
by wife-ABL king-ABL.SG-DEF
'by the wife of the king'

Normally, the complement of a noun is expressed in genitive case. However, if the head is ablative or instrumental, the genitive case can be overwritten. This overwriting, though, is apparently optional: (375) shows a minimal pair with overwriting in (375b) but no overwriting in (375a).

In truth, Caha suggests in footnote 20 that this overwriting process is not optional, but that GEN nouns have access to two distinct positions— one where agreement is obligatory, and one where agreement is not allowed. Movement of the other noun obscures the distinct positions. Given that he asserts that these genitive elements are “complements” of the leftmost noun, perhaps the non-agreeing position is a specifier (i.e., a possessor).

Caha also asserts that case attraction is not iterable on the basis of (374)— notice that *Hayoc* 'Armenian' bears genitive case-marking, not instrumental case-marking. Of course, given that overwriting is 'optional', we do not know for sure what is happening in (374)— but iterated overwriting is apparently unattested.¹⁴

Caha does not provide a detailed analysis of case overwriting— he presents the data as further support for the broader proposal he makes about the structure of Classical Armenian's case paradigm. He suggests that agreement involves “a separate base-generation of case features

¹⁴The source for Caha's examples of case overwriting in Classical Armenian (Plank 1995) provides only a couple of examples, though Plank does state that examples of iterated overwriting are unattested.

on top of the agreeing constituent.” Under Caha’s proposal, case is not represented as a feature or features on heads or phrases, but as hierarchically-ordered syntactic terminals. Caha does not provide an example of what such a structure would look like, and I will not attempt to construct one.

The agreement is actually enforced at LF, where features “must match with the case features base-generated on the head noun.” Caha does not specify how this matching is calculated, and I will not attempt to do so here. What I would like to note, though, is that this sort of analysis appears to suffer from a lookahead problem. Based on Caha’s discussion, I assume that ablative and instrumental (the cases that apparently overwrite) are not freely available on noun complements. Crucially, the lower nominal can generate the terminal nodes necessary for those cases only if the higher nominal generates them, too. In other words, if agreement is base-generated (as Caha suggests), then the complement of the head noun must “know” that it is inside of an ablative nominal (i.e., that the higher noun will be ablative) “before” the head noun’s ablative features are merged. This is not an argument against Caha’s approach to case-marking in general, but it is a direct result of attempting to use base-generation— a module that by hypothesis builds representations from the bottom up— to analyze a phenomenon that intuitively operates from the top down.¹⁵

That being said, it is quite unclear to me how Caha’s assumptions about case values can be incorporated into our general assumptions about agreement processes. For Caha, case values are not features on heads that can be valued or unvalued— they emerge from constellations of syntactic terminal nodes. Thus, a process of case agreement can be represented in one of two ways:

- (i) base-generation of the syntactic structure (i.e., the features) necessary for both elements to bear the same case values;
- (ii) agreement leading to the **creation of additional syntactic material** (i.e., particular terminal nodes recursively embedded) lower in the tree.

As mentioned, option (i) leads to lookahead problems. Option (ii) seems to violate standard assumptions about structure-building— it would require breaking a representation at a point

¹⁵This kind of analysis can be made to work if we assume that the “bad” structures can indeed be built, but they are ruled out by some other mechanism. I will not develop such an account here.

and inserting more structure in between the two pieces. I am not aware of any analyses where merger of higher heads leads to *the creation of structure* lower in the structure. These seem like significant obstacles to the kind of analysis that Caha (2013) proposes, and I thus do not pursue such an account of case concord in Estonian pseudopartitives.

4.4.3 Interim summary: nominative and accusative are special

The descriptive hierarchy of cases in Estonian is repeated below.

(358) Estonian case hierarchy:

MATCHING CASES >> PARTITIVE >> NOMINATIVE, ACCUSATIVE

In order to derive the hierarchical effects, we must key in to some commonality which links the matching cases or a common property which links nominative and accusative. To that end, I would like to take a moment to discuss what those commonalities might be.

It is difficult to find a clear unifying thread among the matching cases. On the one hand, they include the three interior local cases (illative, inessive, elative), the three exterior local cases (allative, adessive, ablative), and the translative case. These are traditionally called semantic cases, and I believe it would be relatively uncontroversial to treat them as inherent cases, assigned by particular lexical items. More strongly, Nikanne (1993) proposes that such cases in Finnish are assigned by covert P⁰-heads. This analysis makes it clearer why genitive might behave like the semantic cases, as genitive is the most common case assigned by adpositions in Estonian.

As for the partitive pattern, it only surfaces when the case assigned to the entire pseudopartitive is nominative or accusative. These are the cases that are often defined as being configurational— that is, assigned purely on the basis of syntactic structure, regardless of the identity of particular lexical elements populating that syntactic structure. This is especially true in Estonian, where nominative and accusative are only ever assigned to arguments in the verbal extended projection.¹⁶ Nominative and accusative are not assigned by adpositions, and they

¹⁶For nominative, this is a bit of an oversimplification, as it can be shown that the default morphological case in the language is nominative (visible, for example, in left dislocation structures like that in (i)).

- (i) Naabri lille-d, ne-id ei tohi puutu-da.
 neighbor.GEN flower-PL.NOM they-PL.PAR NEG allow.BARE mess.with-DA
 ‘The neighbor’s flowers, you’re not allowed to mess with them.’ (MK, Volunteered)

cannot be introduced as modifiers of nouns or adjectives.

Partitive case assignment in Estonian pseudopartitives involves the internal makeup of nominal phrases. The cases that show the matching pattern are visible in many components of the grammar and are plausibly connected to P^0 -heads. Nominative and accusative cases, on the other hand, have nothing to do with the internal syntax of nominal phrases; nominative and accusative are assigned purely on the basis of clausal syntax. This does not seem like an accidental generalization— the only cases that result in the partitive pattern are the cases that show little evidence of a connection to the nominal domain.

In the remainder of this chapter, I will pursue an account of case-marking in Estonian pseudopartitives that derives the distributions of the partitive pattern and the matching pattern as a matter of timing: nominative and accusative case are assigned too late to affect case-marking internal to the pseudopartitive itself. In section 4.5, I consider and reject a timing analysis based on phases (Chomsky 2000, 2001). While this account is promising for pseudopartitives and numeral-noun constructions in isolation, it makes the wrong predictions when they come together. The phase-based analysis is ultimately too local. In section 4.6, I propose that partitive case in pseudopartitive is an unmarked case, assigned to complements of nouns that are not already case-marked. This analysis is slightly less local than the phase-based analysis, and it extends nicely to the combination of pseudopartitives and numeral-noun constructions.

4.5 The Phase-Based Spell-Out approach to timing

The first timing-based approach to the partitive pattern is based on phases and Spell-Out. As a syntactic derivation proceeds, parts of the structure (i.e., phases) become closed off at regular intervals. The pieces of phases cannot be accessed by further syntactic operations. The essence of this approach, which I call the Phase-Based Spell-Out analysis, is that the partitive-marked phrase is a phase, and it undergoes Spell-Out *before* the nominative/accusative case-assigner is merged. Thus, the words inside the partitive-marked phrase have already been inserted and are consequently frozen in partitive case.

Before presenting that part of the analysis, I would like to spell out some assumptions about the nature of the matching cases that will be necessary for both this analysis and the one presented in section 4.6.

4.5.1 Preliminaries on case

In Bittner & Hale's (1996) model of case assignment, nominative and accusative (and ergative and absolutive) are distinguished from other cases by syntactic aspects of nominal projections. The core of their proposal is a K^0 head, which serves as the locus of syntactic case features. In their system, DPs with inherent case-marking are analyzed as KPs headed by a K^0 head that is born with a particular case value. For example, Estonian would have $K^0_{[ALL]}$ for allative case, $K^0_{[TRL]}$ for translative case, and so on. In contrast, there are no K^0 heads inherently specified as nominative or accusative. Following Yip, Maling & Jackendoff (1987), Marantz (1991), Bittner and Hale assume that these cases are assigned configurationally. They propose that there is a K^0 head with no inherent feature, and that K^0 head ultimately ends up being realized as accusative or ergative. They propose that nominals marked nominative/absolutive have no K^0 head at all.

Bittner and Hale's KP proposal provides a very clear way to think about the choice between matching pattern and partitive pattern. There are three possibilities for a complete nominal. It can be headed by an inherent K^0 , it can be headed by a valueless K^0 , or it can lack a K^0 entirely.

(376) Inherent K^0

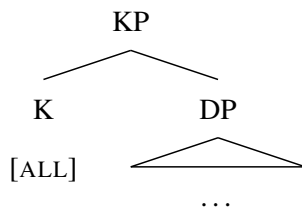

(377) Valueless K^0

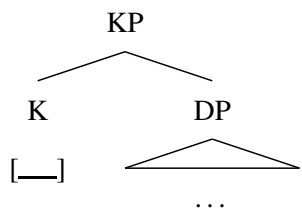

(378) No K^0

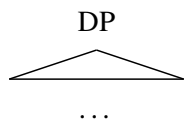

Among these choices, (376) will always lead to the matching pattern. The other two result in the partitive pattern. What this means is that, by the time an entire pseudopartitive is built,

the structure has all the information necessary to determine whether partitive case will surface on the N2 phrase (= the partitive pattern) or not (= the matching pattern). It is only when we need structural information beyond the KP/DP that the partitive pattern emerges. This is the distinction that I will focus on in the what follows.

4.5.2 The Phase-Based Spell-Out analysis

The Phase-Based Spell-Out analysis starts from roughly the same point as the morphological analyses sketched in section 4.4. Let us assume that N1s are case-assigners, assigning partitive case to their complements. I formalize this by treating the embedded N2 phrase as a KP headed by K^0 with no case value.¹⁷

(379) *Partitive case assigned by N1*

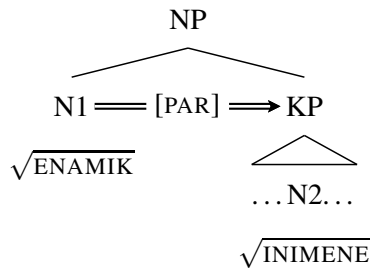

At this point in the derivation, there is no way to tell where this pseudopartitive will be merged within the larger syntactic structure. More pointedly, there is no way to tell whether the pseudopartitive pieces in (379) will end up being in a pseudopartitive that bears the matching pattern or the partitive pattern. In the matching pattern, partitive case no longer surfaces. If we assume that N1 assigns partitive case to the N2 phrase, then we owe an explanation of the “disappearance” (or more neutrally, the lack) of partitive case.

4.5.2.1 Phase-Based Spell-Out: the matching pattern

I will use adessive case as an example of the matching pattern. If we continue to build the structure in (379), we may eventually reach a K^0 head that is valued, like $K^0_{[ADEJ]}$. This is the context for the matching pattern; clearly, the partitive case on the N2 phrase does not get

¹⁷This is an arbitrary choice— as far as I can tell, everything I say in this section would be compatible with an assumption that N1 selects a KP headed by $K^0_{[PAR]}$.

realized. In the spirit of Pesetsky (2013), let us assume that an element can be “assigned” case more than once. However, I do not follow Pesetsky’s (2013) proposal that these case values can be stacked; rather, I assume cases assigned later simply overwrite the case that was assigned previously.

Thus, when the adessive case value from the higher K spreads as far as the lower KP, it overwrites the partitive that was previously assigned there, and continues to spread all the way to the N2 head. This is represented in (380).

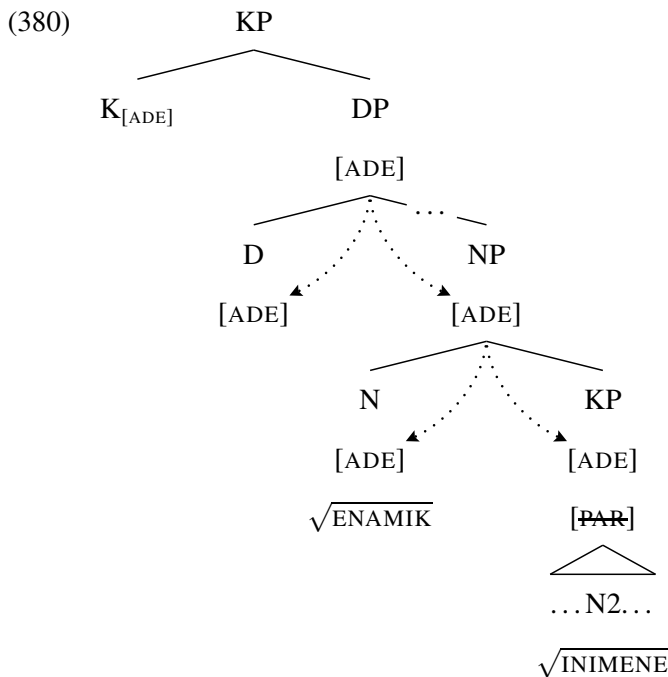

Under this view, the matching pattern is unsurprising— it is simply a consequence of the way case is assigned.

4.5.2.2 Phase-Based Spell-Out: the partitive pattern

But this immediately presents us with a puzzle— how do we prevent accusative case from overwriting partitive in the same way? Assuming (for concreteness) that accusative is assigned by v^0 , we expect accusative to spread all the way down to N2. This cannot be what happens. As we know, nominative and accusative apparently do not overwrite partitive case. Thus, under the current hypothesis (i.e., that case-overwriting happens freely), we must say something to prevent case-overwriting when the potential overwriter is nominative or accusative.

What I propose instead is that nominative and accusative fail to overwrite N2's partitive case because, by the time that nominative or accusative is assigned to the entire pseudopartitive, the N2 phrase has already been spelled out; in other words, the elements of the N2 phrase have already undergone Vocabulary Insertion.

There are a number of concrete assumptions that are required for this analysis. First, I assume that syntactic material is built incrementally, and at certain designated points, pieces of syntactic structure are closed off and are interpreted at both the semantic and the morphophonological interfaces (Chomsky 2001). These domains are called SPELL-OUT DOMAINS. Spell-Out domains are the complements of certain designated PHASE HEADS, which I assume include at least K^0 , v^0 , and C^0 (Chomsky 2000, 2001, Svenonius 2004). Phase heads are so named because their maximal projections are generally called PHASES. I follow Chomsky (2001), Embick (2010) in assuming that, when a phase head is merged, any phases *in its complement* undergo Spell-Out, i.e., they send *their* complements to the morphophonological and semantic interfaces; this is sometimes called Delayed Spell-Out. What is crucial for the Phase-Based Spell-Out analysis is that merging a phase head does not immediately trigger Spell-Out of its complement.

What this means for pseudopartitives is that the N2 phrase is not sent to Spell-Out as soon as it is built, but when the entire pseudopartitive is built. This is represented in (381) below. Phases are in boxes, and phase heads are in dashed boxes. Merging the higher K^0 triggers Spell-Out of the lower KP phase. This means the complement of the lower K^0 head is closed off and sent to the interfaces. This is indicated by the dashed arc.

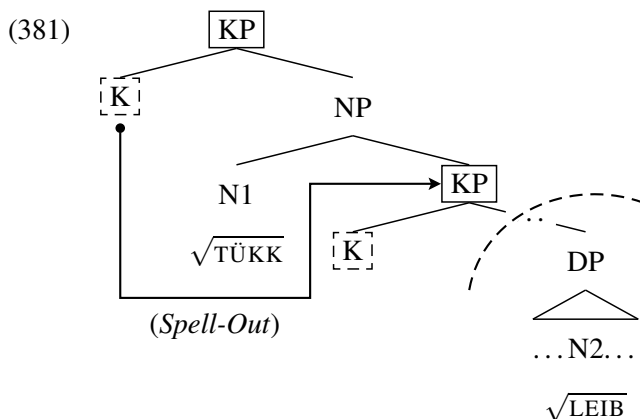

The appeal of a timing analysis based on phases is that phases are, in a sense, indicators of timing within a derivation. Material merged later might not be able to affect material merged

earlier in the derivation.

With this in mind, consider a pseudopartitive showing the partitive pattern, as below:

- (382) *koti* *kartule-id*
 bag.ACC potato-PL.PAR
 ‘bag of potatoes’

Let us adopt Bittner & Hale’s (1996) proposal that accusative nominals are headed by an unvalued K^0 . When the entire pseudopartitive is built, we arrive at the structure in (383).

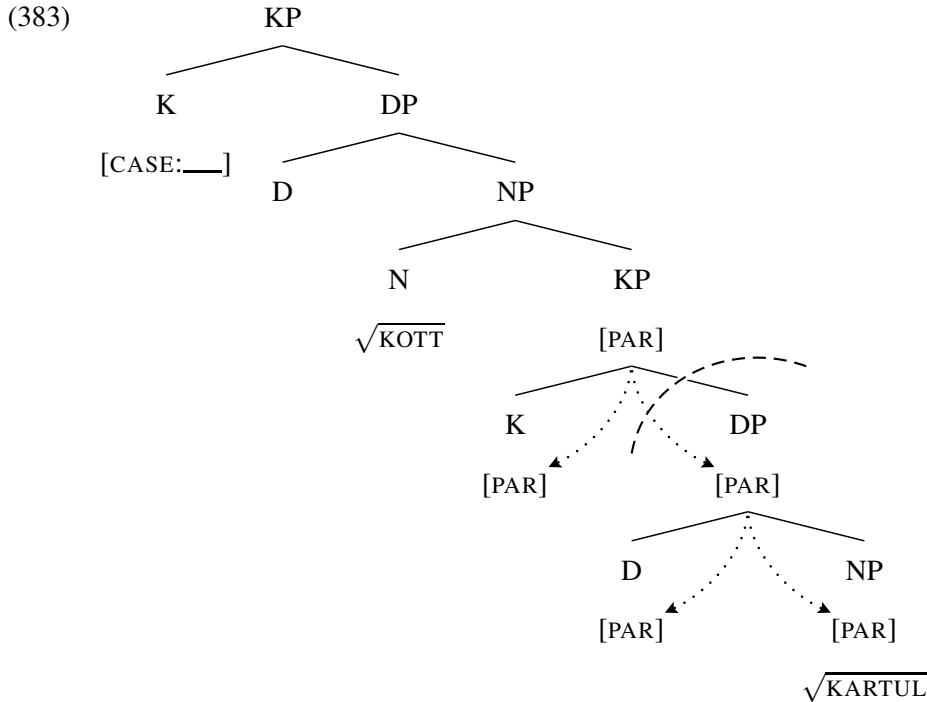

Note that in this structure, we have a KP phase within the complement of another phase head. Thus, at this point, the lower K^0 head triggers Spell-Out of its complement (indicated by the dashed arc). Nothing has overwritten partitive at this point, and thus the N2 phrase is spelled out with partitive case.

- (384) N2 phrase Spell-Out (simplified):
 $\sqrt{KARTUL}, [PAR, PL] \leftrightarrow kartuleid$

At some point later in the derivation, accusative case is assigned to the entire pseudopartitive. For concreteness, I take it that accusative is assigned by v^0 .

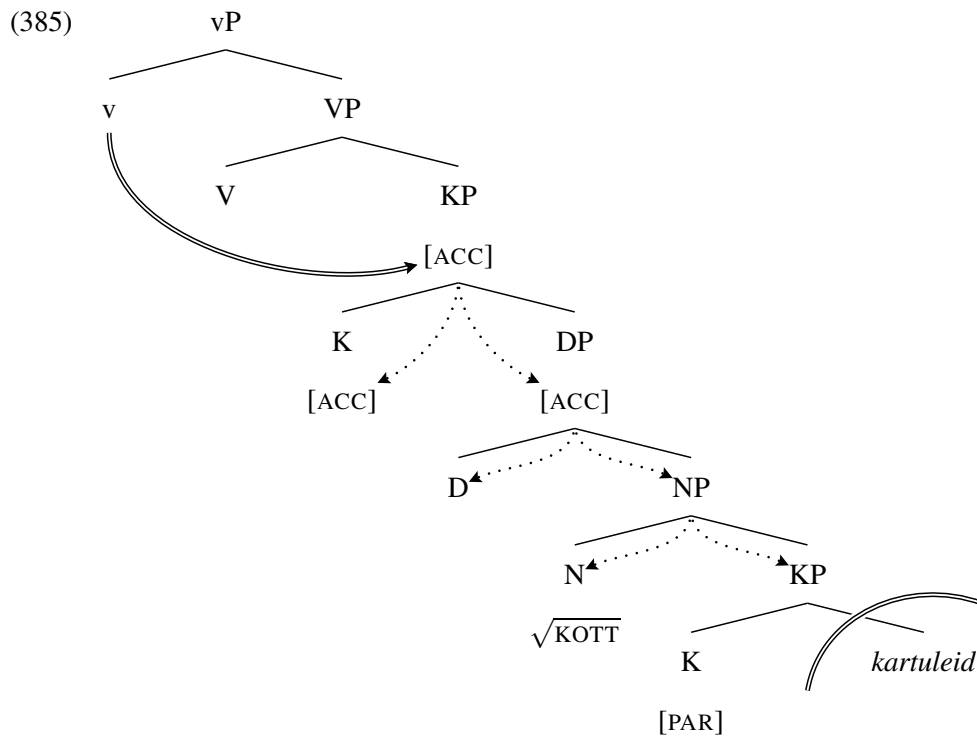

Accusative spreads as normal after being assigned, but it is too late to affect N2, because *kartuleid* ‘potatoes’ has already been spelled out. I assume, as is standard, that when a word or phrase has undergone Vocabulary Insertion, it cannot be changed by further syntactic processes. This is the essence of the Phase-Based Spell-Out timing analysis. It is not that accusative as a case is incapable of overwriting previously assigned cases, it is just that it is assigned too late to have any effect on the partitive case inside of pseudopartitives. By the time accusative case is assigned to the pseudopartitive, the N2 phrase has already undergone Vocabulary Insertion.

4.5.3 Extending the analysis to numerals

At this point, we have seen many times that Numeral-Noun Constructions (NNCs) involve the assignment of partitive case to the complement of the numeral head *Card*⁰. Just as in pseudopartitives, partitive case only surfaces if the NNC is in a position to receive nominative or accusative case. If the NNC receives any other case, we see the matching pattern (as in (386b)).

- (386) a. *kõik kolm küsimus-t*
 all.PL 3 question-PAR
 ‘all three questions’

- b. kõiigi-le kolme-le küsimuse-le
 all.PL-ALL 3-ALL question-ALL
 ‘to all three questions’ (PARLIAMENT)

I take it to be the null hypothesis that whatever explanation we provide to the case-marking seen in pseudopartitives should extend to the case-marking seen in NNCs.

Under the Phase-Based Spell-Out analysis, this means that, in addition to KP, vP, and CP, CardP must be a phase. In other words, Card⁰ must be phase-defining in Estonian. Thus, when an entire NNC is built, the K⁰ head triggers Spell-Out of the phase headed by Card⁰.

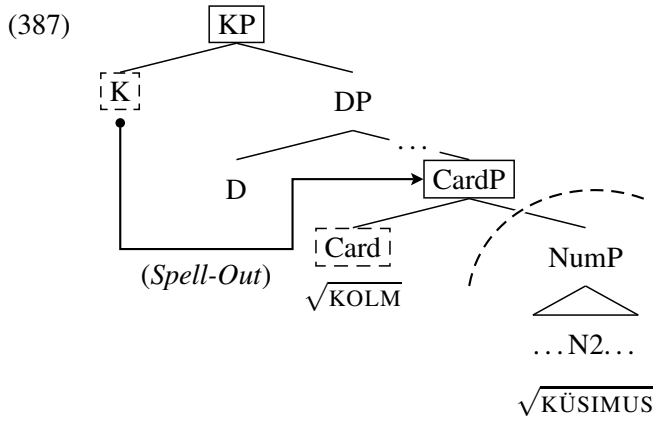

As before, I assume that Card⁰ assigns partitive case to its NumP complement. However, when a K⁰ head with an inherent value (like K⁰_[ADE]) is merged, the case on NumP is overwritten. In contrast, nominative and accusative are not assigned until after the KP is built, which means they are assigned too late— in these contexts, the NumP has already undergone vocabulary insertion, and its form is frozen. Just as before, the reason that the partitive pattern emerges for nominative and accusative case is because they are not at play in KP-internal case assignment.

4.5.4 Extending the analysis once more: Stacking NNCs and pseudopartitives

It is possible to merge a numeral with a pseudopartitive, creating an NNC-pseudopartitive stack like those below.

- (388) kolm kotti kartule-id
 3.NOM bag.PAR potato-PL.PAR
 ‘three bags of potatoes’ (EKSS, entry for *kott*)

- (389) pool liitri-t piima
 half.NOM liter-PAR milk.PAR

'half a liter of milk'

(EKSS, entry for *pool*)

I will call examples of this kind M-STACKS (for “measurement” stacks). The examples above are citation forms, so they are in a nominative environment. They thus show the partitive pattern. The numeral bears nominative case, and both the N1 and the N2 of the pseudopartitive bear partitive case. The structure of M-stacks that I will assume in what follows is presented below.

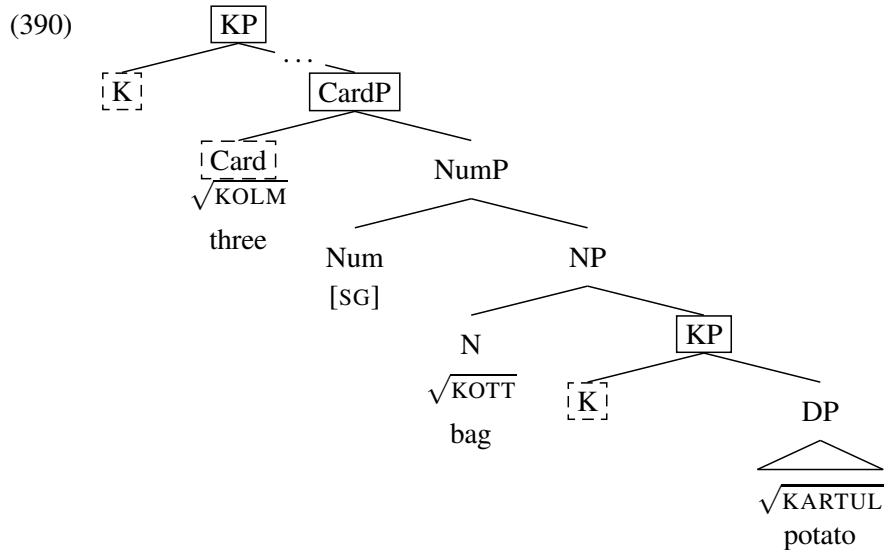

This structure is just the syntax of an NNC stacked on top of a pseudopartitive. As before, the cardinal numeral takes a NumP complement, and N1 takes a KP complement (assuming the Phase-Based Spell-Out analysis).

While accounting for the partitive pattern is unproblematic, the Phase-Based Spell-Out analysis makes an interesting prediction with regard to the matching pattern. In what we have seen up until this point, there have only been two phase heads within the entire nominal phrase: the K^0 head and the lower head (K^0/Card^0). Note that in M-stacks, there are *three*: higher K^0 , Card^0 , and the lower K^0 , all in dashed boxes in (390). Taking seriously the analysis of case-marking in NNCs and pseudopartitives on their own, note that the lowest phase (i.e., the N2 phrase), is spelled out when Card^0 is merged. In other words, it is spelled out *before* the entire M-stack is built.

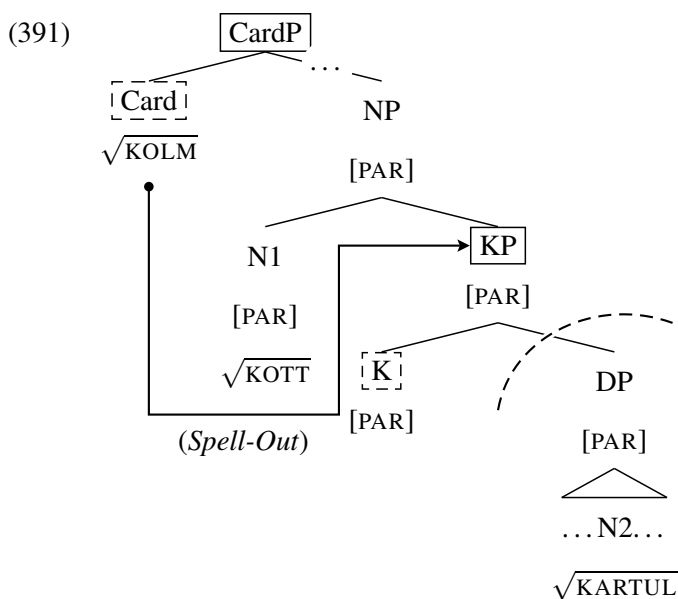

In (391), Card^0 has already assigned partitive case to its complement, thus N1 and N2 are both marked with partitive case. Card^0 also triggers Spell-Out of the lower KP phase, which means the N2 phrase will undergo Vocabulary Insertion marked with partitive case.

(384) N2 phrase Spell-Out (simplified):

$\sqrt{\text{KARTUL}}$, [PAR, PL] \leftrightarrow *kartuleid*

Thus, the prediction that the Phase-Based Spell-Out analysis makes is that the case-marking on the N2 phrase will be frozen (as partitive) before the highest K^0 is merged. In other words, the Phase-Based Spell-Out analysis predicts that the “matching pattern” of an M-stack will not involve full matching, but rather, the N2 phrase will always be marked with partitive case.

This prediction is not borne out. M-stacks in matching pattern contexts show full case matching:

(392) a. Riidevärv sula-ta-takse poole-s liitri-s vee-s.
 dye melt-CAUS-PASS half-INE liter-INE water-INE
 ‘One dissolves the dye in a half liter of water.’ (EKSS, entry for *liiter*)

b. * Riidevärv sula-ta-takse poole-s liitri-s vett.
 dye melt-CAUS-PASS half-INE liter-INE water.PAR

(393) a. kolme koti kartuli-te kõrval
 3.GEN bag.GEN potato-PL.GEN next
 ‘next to three bags of potatoes’

- b. * kolme koti kartule-id kõrval
 3.GEN bag.GEN potato-PL.PAR next

In (392a), the M-stack is in inessive case, and the inessive case is realized on each element, including *vee-s* ‘water-INE’. In (393a), all three elements are genitive. Changing the second noun to be partitive (as in (392b) or (393b)) is ungrammatical.

The Phase-Based Spell-Out analysis is tied directly to the *number* of phase heads that have been merged rather than the nature of the phase heads. Consider the schematic context below, where there are three recursive phases.

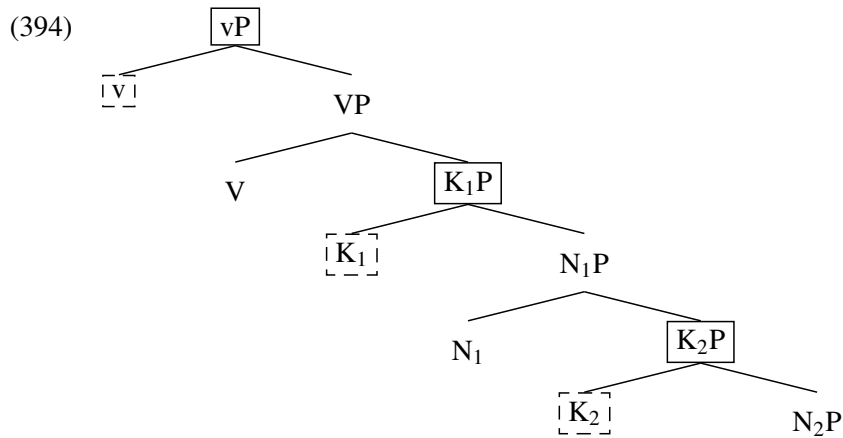

What is at stake is which heads among those above can affect N_2P before it is sent to Spell-Out. Under the Phase-Based Spell-Out analysis, material in between and including K_1^0 and K_2^0 can affect N_2P , but material external to that (e.g., V^0 , v^0) cannot. This led to the correct prediction that cases assigned external to K_1P (i.e., nominative and accusative) cannot affect case-marking on N_2P . That is the partitive pattern.

Note that the structure for M-stacks is the same as the structure in (394)— the phases simply have different labels.

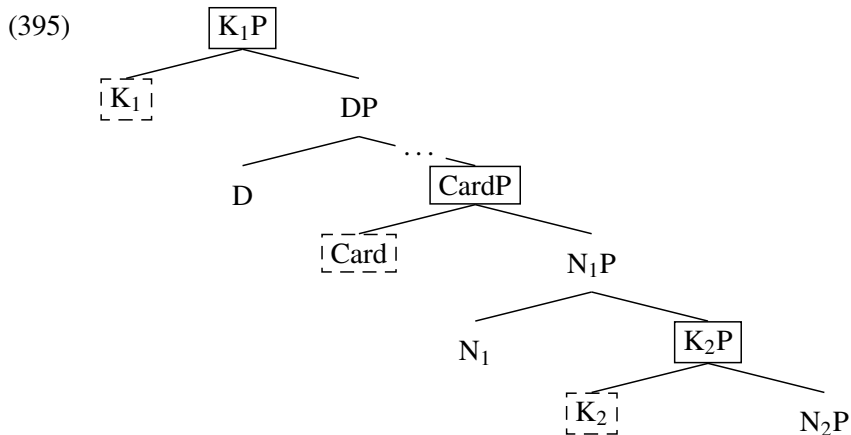

Note that in this case, it *must* be possible for K_1^0 to affect the form of N_2 , because if K_1 is e.g., inessive case, then N_2 will also bear inessive case. However, the Phase-Based Spell-Out analysis does not allow that kind of interaction to take place (and it *cannot*, lest we lose our understanding of the partitive pattern). The phase-based locality imposed by Phase-Based Spell-Out analysis is too strong.

I will now pursue an analysis that does not rely on a strict number of phases, but rather, on a distinction between cases assigned by verbal functional heads on the one hand and cases assigned in the nominal domain on the other.

4.6 Partitive as an unmarked case inside nominals

Let me take a brief moment to reiterate what the goal of the last section and this section is. It is possible to generate the alternation between the matching pattern and the partitive pattern (even in M-stacks) by appealing to a stipulated case hierarchy. We simply say that nominative and accusative are “weaker” than partitive and all other cases are “stronger.” However, such a hierarchy must be stipulated, and it seems to me that nominative and accusative form a natural class. The goal of the last section and this section is to seek an explanation of the observed hierarchical effects on the basis of independently-necessary properties of the cases in question.

In this section, I will pursue the idea that partitive case is an UNMARKED CASE inside of KPs. If we make the claim in (396), the alternation between the partitive pattern and the matching pattern falls out quite naturally.

(396) **Unmarked Partitive Hypothesis:** Partitive case in Estonian nominals is an unmarked

case, assigned to complements of nouns that do not already have a case-value.

The hypothesis in (396) is couched within the same general framework of case as proposed by Marantz (1991) and developed in subsequent work.

The essence of Marantz's proposal and the work that it has inspired is that there is more than one way for a DP to end up bearing morphological case. One way is for a DP to be assigned case by the V^0 or P^0 that selects it. This is so-called lexical/inherent case, and in Marantz's system, it is assigned first. DPs that are not assigned lexical/inherent case may be subject to case competition, which involves two caseless DPs in an asymmetric c-command relationship. Dependent case is the case assigned to one of the two DPs in such a situation—accusative, for example, is assigned to the lower of two DPs in case competition. Dependent case has received the most attention so far as I know (see Baker & Vinokurova 2010 on Sakha or Poole 2014 on Finnish, for example). Case competition (and the assignment of dependent case) occurs second in Marantz's system.

For DPs that still remain caseless, Marantz suggests two possibilities, but these possibilities are often collapsed. The first is default case: that case assigned to any DP that remains caseless when all is said and done. Schütze (2001) identifies a number of domains where DPs cannot receive case for whatever reason, and these are DPs which unquestionably receive some sort of default in many languages. There is also a kind of domain-specific default case, which Marantz calls UNMARKED CASE. The key claim is that unmarked case “may be sensitive to the syntactic environment; for example, in a language GEN may be the unmarked case for NPs inside NPs (or DPs) while NOM may be the unmarked case inside IPs.” Marantz does not explore unmarked case in detail, focusing the discussion instead on dependent case. Subsequent research has followed suit.

I claim that partitive case in Estonian pseudopartitives and numeral-noun constructions is an unmarked case. It is assigned to complements of nouns that do not already have a case-value. However, this assignment does not happen immediately— in other words, in the Unmarked Partitive analysis, partitive case is not assigned “by N1” per se. Instead, when the N1 is first merged with the N2 phrase, there is no case assignment. Unmarked case is not assigned until the nominal extended projection is complete (e.g., a phase head is merged). It is only when the entire KP is built, as in (397), that the conditions for unmarked case can be checked.

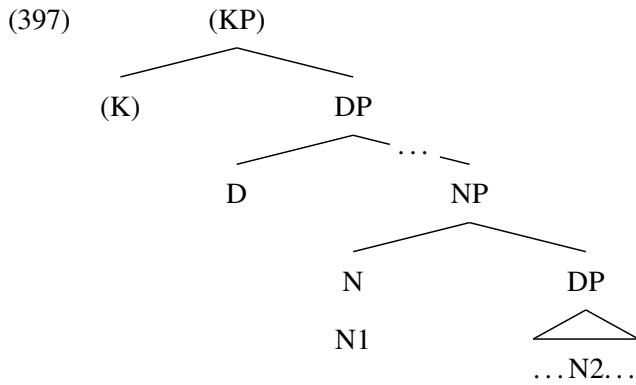

The simplest case is when the K^0 head has an inherent value— this leads to the matching pattern.

4.6.1 Unmarked Partitive: the matching pattern

When a head like $K^0_{[ADE]}$ is merged, its case value is spread all the way down to the N2 in the normal fashion.¹⁸

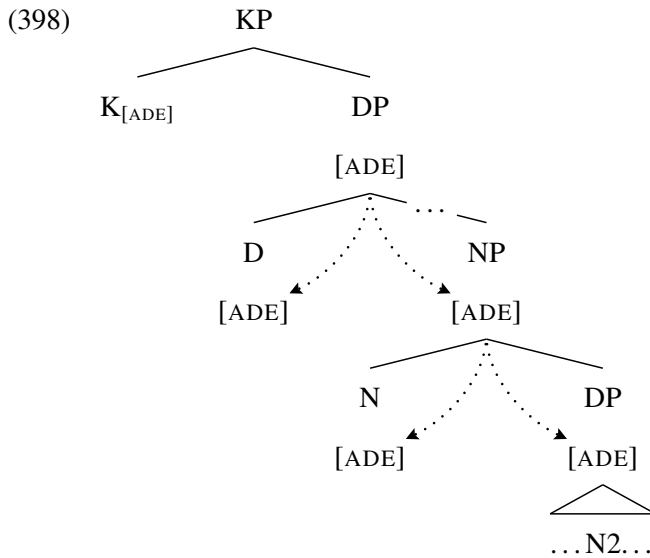

¹⁸We can think of this in one of two ways. Either (i) these K^0 heads actually assign their case to the complement, or (ii) case features that are instantiated on K^0 are also instantiated on projections of K^0 , including the projection labeled KP. I assume that case features may spread (due to case concord) as normal from the KP node. I do not decide between these two alternatives here.

Because the N2 phrase has no case value of its own under the Unmarked Partitive Hypothesis, adessive case spreads all the way down to N2 itself. The result is that all the elements in the entire pseudopartitive are marked with adessive case, i.e., the matching pattern. It is not necessary to appeal to case overwriting (or case hierarchies) in order to predict the matching pattern, because partitive is never assigned to begin with. The conditions for Unmarked Partitive are checked in the structure in (398), but since the complement of N^0 already has a case value, unmarked case is not assigned.

4.6.2 Unmarked Partitive: the partitive pattern

If, instead of an inherent- K^0 , the structure in (397) finishes with an unvalued K^0 or no K^0 at all, we see the partitive pattern. Let us consider what happens for the accusative specifically. In this instance, a K^0 -head is merged, but there is no case value, so nothing happens— the N2 phrase remains caseless.¹⁹

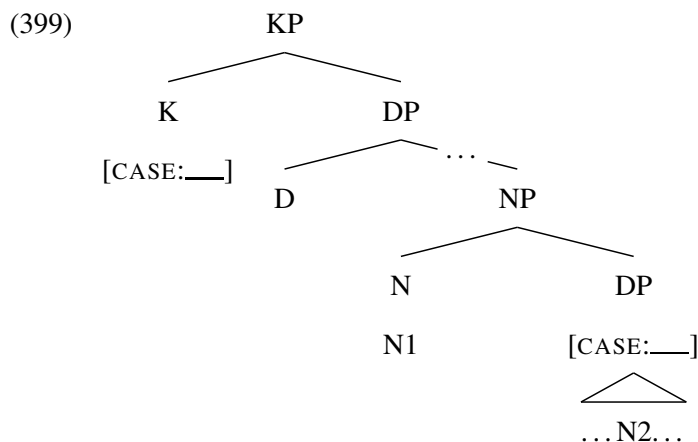

Thus, the nominal constituent KP is complete, but it lacks a case value. To speak informally, this is the moment when partitive case surfaces: there is a caseless nominal complement of an N^0 head. This is the environment that underlies the assignment of partitive case in the Unmarked Partitive analysis, and so, the N2 phrase is marked with partitive case.

¹⁹I set aside the question of how the right kinds of KPs are licensed in the right positions. The proposal that Bittner & Hale (1996) themselves propose is throughout their paper, though see especially pp. 1–12.

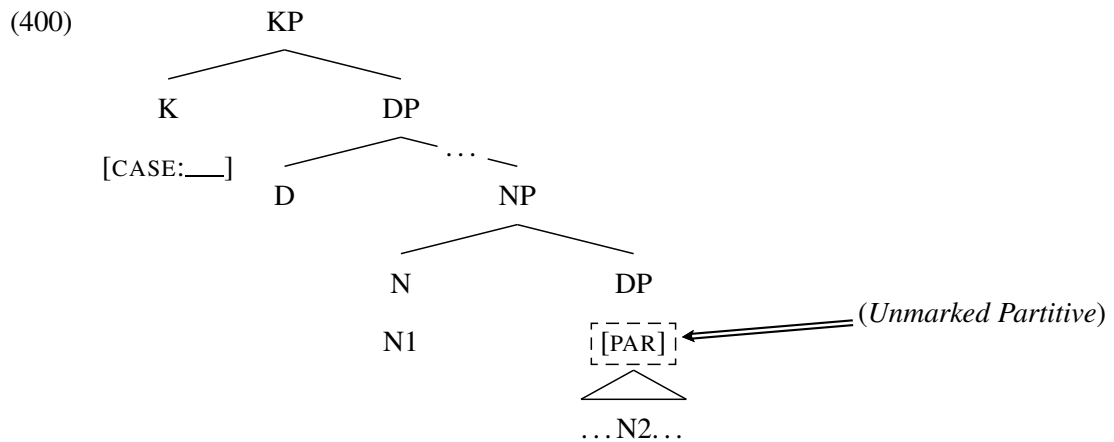

Case concord ensures that partitive will then spread throughout the DP.

When accusative is assigned to the entire pseudopartitive, it spreads as far as the N2 phrase. To generate the partitive pattern, accusative spreading must stop there. My analysis of this fact is that there is no case overwriting in Estonian. Once a node already has a case value, that value cannot be replaced. Accusative thus cannot spread to the N2 phrase, because the N2 phrase already has a case value (partitive). So, when a KP like the one above is ultimately in the right environment for accusative case,²⁰ that accusative case value only spreads as far as N1.

²⁰The inner workings of the Estonian accusative are complex, and I will set aside their investigation until a later date. For analyses and discussion of the structural case system of Finnish, which is similar in many ways but slightly different from that in Estonian, see Kiparsky (2001), Poole (2014), Vainikka (1993).

(401)

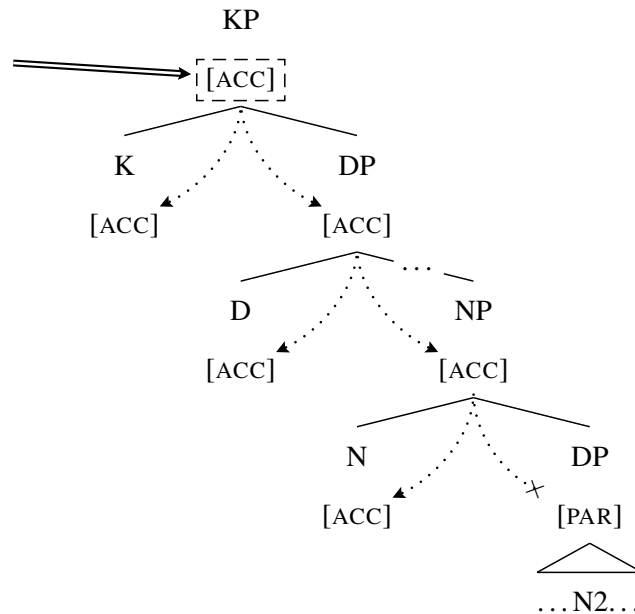

This analysis can account for the matching pattern without appealing to a mechanism of case overwriting. The trouble with case overwriting is that it cannot uniformly apply. It must apparently be sensitive to the particular value of case at play. In the Unmarked Partitive analysis, the choice between the partitive pattern and the matching pattern is due to order of operations. Because partitive only emerges as a default, it only surfaces when the entire KP does not already have its own case-value— in other words, when the entire KP will ultimately be assigned nominative or accusative case. When the entire KP bears some other case value (e.g., illative), partitive case is not assigned.

The analysis can also account for the case alternation seen in M-stacks. Let us return to those patterns.

4.6.3 Extending the analysis to M-stacks

I use the term M-stack to refer to a numeral-noun construction stacked on top of a pseudopartitive. M-stacks also show an alternation between a partitive pattern and a matching pattern, as shown below.

(402) M-stacks: partitive pattern

- a. kolm kotti kartule-id
 3.NOM bag.PAR potato-PL.PAR
 ‘three bags of potatoes’
- b. pool liitri-t vett
 half liter-PAR milk.PAR
 ‘half a liter of milk’

(403) M-stacks: matching pattern

- a. kolme koti kartuli-te
 3.GEN bag.GEN potato-PL.GEN
 ‘three bags of potatoes (genitive)’
- b. poole-s liitri-s vee-s
 half-INE liter-INE water-INE
 ‘in half a liter of water’

Extending the Unmarked Partitive analysis developed above for pseudopartitives to NNCs is fairly straightforward. In chapter 2, I gave numerals the label Card^0 , though this was an assumption rather than a proposal. If the Unmarked Partitive hypothesis is on the right track, then I conclude that numerals in Estonian are not Card^0 heads, but nouns, following Ionin & Matushansky (2006).²¹ A revised structure for NNCs is given below.

(404) New NNC structure for the Unmarked Partitive analysis:

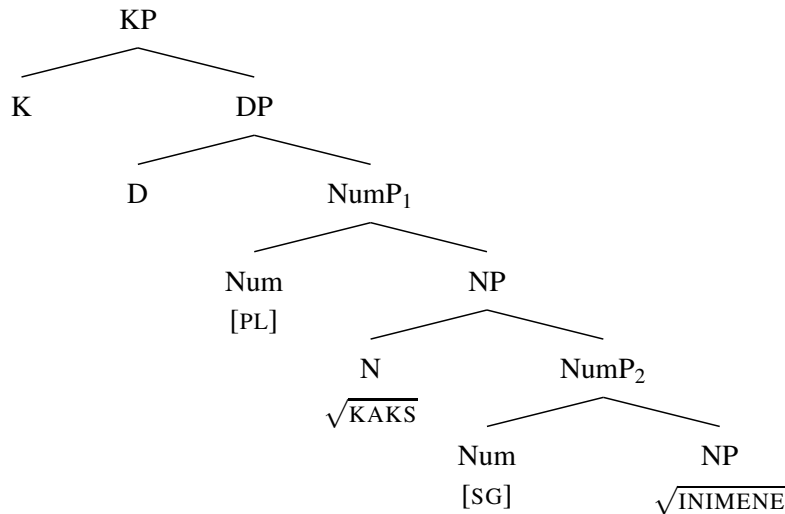

Accounting for the matching pattern and the partitive pattern in numeral-noun constructions proceeds as with pseudopartitives. When the KP is built, if the K^0 head has a value, then

²¹The question of category label for cardinal numerals is a matter of ongoing debate, though most conclude that they are either nominal or adjectival. There are compelling arguments in favor of both analyses. If it turns out that a nominal analysis of numerals cannot be maintained, then we would need to revise the conditions under which partitive case is assigned. One idea would be to say that, though cardinals are not the same thing as nouns, they have a feature in common with nouns (that elements like D^0 lack). In other words, numerals might not be nouns, but they are still noun-like enough to trigger the assignment of partitive case.

that value is spread throughout the NNC. If the K^0 head does not have a value, the lower NumP₂ is assigned partitive case, because it is the complement of a noun (i.e., the cardinal numeral).

When the two combine to form an M-stack, nothing additional needs to be said about the partitive pattern. If the entire M-stack is headed by a K^0 with no value, then the unmarked partitive rule applies: both NumP and the lower DP are assigned partitive case.

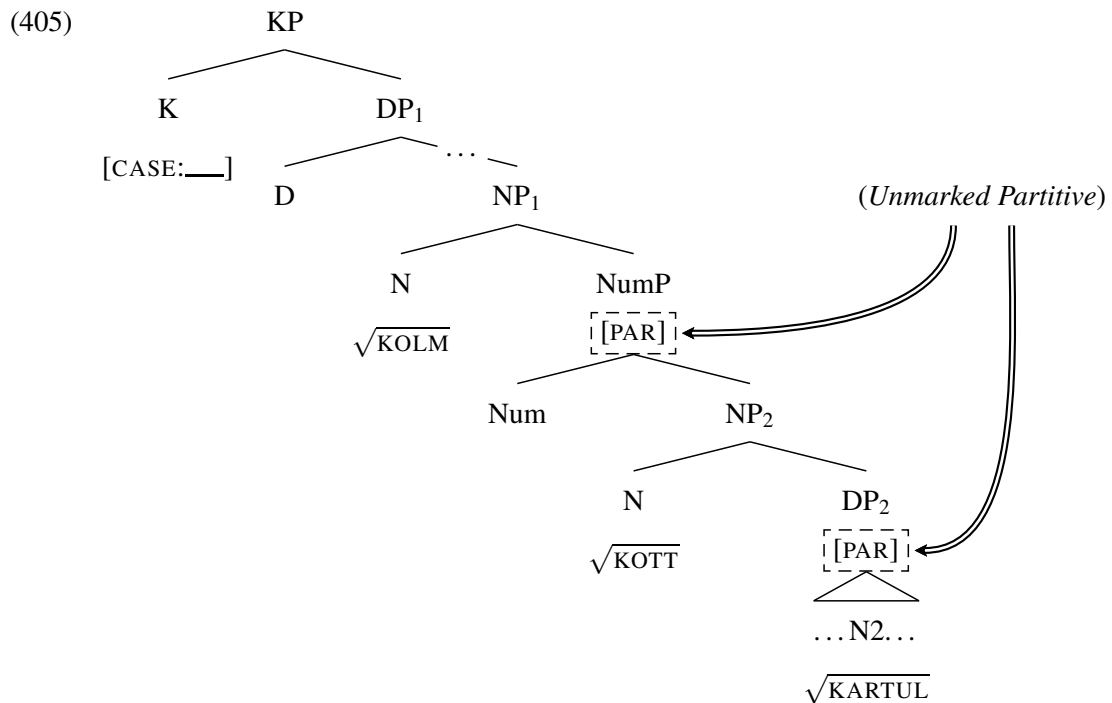

I added subscripts to the NP and DP nodes in order to be able to refer to them. Note that I assume that partitive case is assigned to two constituents: NumP and DP₂. The partitive case that is assigned to DP₂ and the partitive case that is assigned to NumP are totally independent of each other. They both depend on the K^0 head of KP. This is an important difference between the Unmarked Partitive analysis and the Phase-Based Spell-Out analysis.

In the Phase-Based Spell-Out analysis, the partitive case on NumP is still dependent on the higher K^0 , insofar as that head is the closest phase head. However, the partitive case on DP₂ is dependent on the numeral *kolm* (the head of NP₁) rather than K^0 . Consequently, the predicted conditions for the surface realization of partitive case on DP₂ were distinct from the predicted conditions for the realization of partitive case on NumP. We saw this play out in the derivation of the matching pattern, where the Phase-Based Spell-Out analysis predicted that DP₂ would still bear partitive case. This prediction was not borne out.

Under the Unmarked Partitive analysis, both instances of partitive case are tied to the same conditions. Either both NumP and DP₂ are marked with partitive case, or neither is. In order to predict the matching pattern, this is what we need. The matching pattern emerges when the M-stack is headed by a K⁰ with an inherent value. When this K⁰ merges, its value is spread throughout the M-stack by case concord.

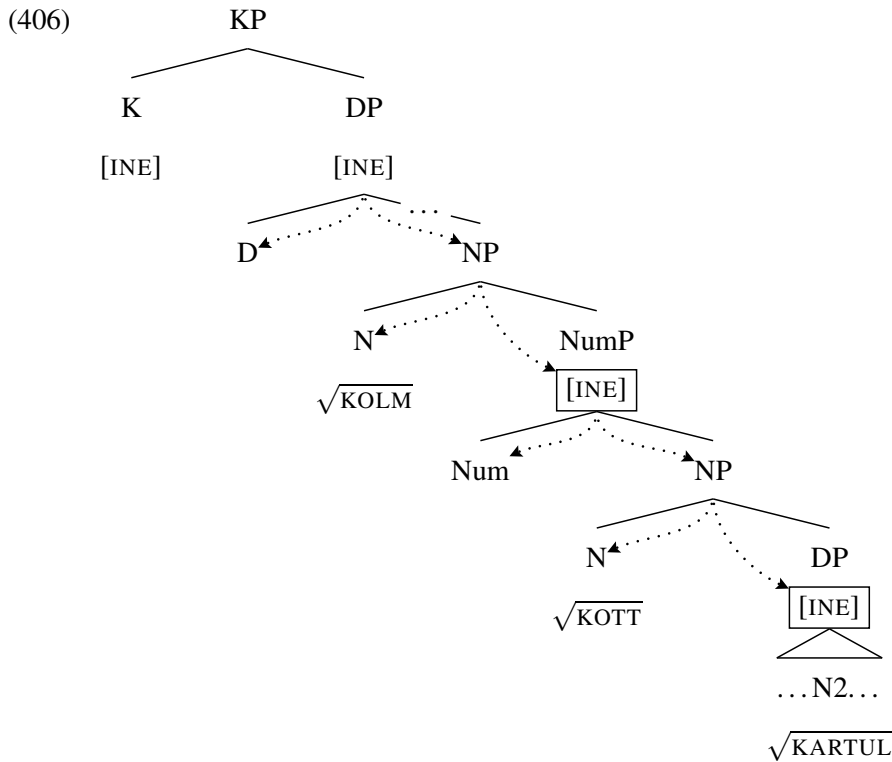

Because both instances of partitive are dependent on the same source (i.e., a caseless complement of N⁰), partitive case is not assigned at all. The conditions for Unmarked Partitive may be checked, but because every N⁰-complement already has a case value, no partitive case is assigned. The result is full matching.

4.6.4 Summary: towards deriving the case hierarchy

The alternation between the matching pattern and the partitive pattern in Estonian pseudopartitives and numeral-noun constructions is descriptively very clear. Similar alternations have been analyzed in previous work as arising due to morphology, either due to the need for some cases to be expressed overtly or due to a morphological algorithm for realizing terminal nodes with

multiple case features. I argued that Estonian is a counterexample to both options.

Another kind of approach is to appeal to a case hierarchy, where the cases showing the matching pattern outrank cases showing the partitive pattern, with the assumption that highest ranking cases must be realized. It may end up that it is not possible to avoid a stipulated hierarchy like this, or perhaps the cost of doing so would be too great. In the previous two sections, I have considered two possible formal explanations of the descriptive hierarchical facts that we observed in Estonian pseudopartitives. While both analyses can account for pseudopartitives or NNCs on their own, only one account (the Unmarked Partitive analysis) shows promise for being able to account for M-stacks, where pseudopartitives and NNCs come together.

Nearby Finnish and the Slavic languages show the same kind of alternation in numeral-noun constructions as we see in Estonian. Some case is apparently assigned by numerals in nominative and accusative contexts, but in other case contexts, the numeral and noun agree. However, Estonian is special in extending this pattern to pseudopartitives (see Koptjevskaja-Tamm (2001) for discussion of its diachronic development in this way). This also means that Estonian is special in having both matching and partitive patterns visible for M-stacks. This makes Estonian an ideal testing ground for potential formal explanations of case hierarchy effects. If what I have presented thus far is on the right track, then appealing to a nominal-phrase internal unmarked case seems to be a promising line of attack for further research.

Yet this raises an interesting question— how can we make sense of languages like Finnish, which show case pattern alternations in NNCs but not in pseudopartitives? I will turn to this issue now.

4.7 Microvariation between Finnish and Estonian

As discussed extensively by Brattico (2010, 2011) and Seppänen (1983), Finnish numeral-noun constructions exhibit the same alternation between case assignment and case matching as we saw in Estonian.

(407) ne kaksi pien-tä auto-a
 those.NOM two.NOM small-PAR car-PAR
 ‘those two small cars’ (Brattico 2010:55)

(408) nii-ssä kolme-ssa piene-ssä talo-ssa
 those-INE three-INE small-INE house-INE

‘in those three small houses’ (Brattico 2010:69)

(409) * *nii-ssä kolme-ssa pien-tä talo-a*
those-INE three-INE small-PAR house-PAR
‘in those three small houses’ (Brattico 2010:69)

In (407), we see that the complement of *kaksi* ‘two’ is marked with partitive case. However, if the entire DP is in another case (e.g., inessive), then everything matches in case, as in (408). It is not possible to leave ‘small’ and ‘house’ in partitive case, as in (409).

Finnish also has a pseudopartitive construction that looks superficially similar to the pseudopartitive construction in Estonian. Brattico (2008) discusses them in some detail, calling them *kasa* constructions. Some basic examples are given below:

(410) a. *Pekka näki kasa-n hiekka-a.*
Pekka saw stack-ACC sand-PAR
‘Pekka saw a stack of sand.’ (Brattico 2008:142)

b. *Kasa hiekka-a oli maa-ssa.*
stack.NOM sand-PAR was ground-INE
‘A stack of sand was on the ground.’ (Brattico 2008:142)

As before, we have what looks like a noun assigning partitive case to another nominal element. Brattico argues at length that the first nominal *kasa* ‘stack’ is the head of the construction, and he assumes it is a normal noun. Thus, we are dealing with a structure that is apparently very similar to the Estonian pseudopartitive.

However, there is an interesting difference between pseudopartitives in Finnish and pseudopartitives in Estonian: Finnish pseudopartitives have no matching pattern. This is visible in the following minimal pairs.²²

(411) Finnish (no matching):

a. *Miten paljon kaloreita on litra-ssa maitoa?*
how many calorie.PL.PAR are liter-INE milk.PAR
‘How many calories are in a liter of milk?’ (Seppänen 1983:164)

b. *siitä jouko-sta auto-ja*
that.ELA set-ELA car-PL.PAR
‘from that set of cars’ (Brattico 2008:146)

²²The Estonian cognate of the Finnish word *joukko* ‘set’ is *jõuk* ‘gang/mob’, but this word is not typically used for inanimate objects like cars, so I have changed it to the more semantically-neutral measure noun *hulk*.

(412) Estonian (matching):

- a. Kui palju kalore-id on liitri-s piima-s?
 how many calorie-PL.PAR be.3 liter-INE milk-INE
 ‘How many calories are in a liter of milk?’
- b. selle-st hulga-st auto-de-st
 this-ELA group-ELA car-PL-ELA
 ‘from this group of cars’

The word for ‘liter’ bears inessive case in both of the (a) sentences above, but the case-marking on ‘milk’ is different: partitive in Finnish, inessive in Estonian. The same is visible in the (b) examples. In Finnish, the N2 phrase always bears partitive case. In Estonian, the N2 phrase matches the case of N1 just as we have seen.

If the Unmarked Partitive Hypothesis can be maintained, then from the Finnish facts, we must conclude that the partitive case in Finnish pseudopartitives does not have the same source as the partitive case in Finnish numeral-noun constructions. I thus propose that the partitive case in Finnish pseudopartitives is not Unmarked Partitive, but inherent partitive. Inherent partitives may be independently necessary in Finnish—for example, partitive is assigned by some (but not all) adpositions. Following the assumptions I have made thus far, I formalize this by proposing that the N2 phrase in Finnish contains a $K^0_{[PAR]}$ -head, but it does not in Estonian.

(413) Estonian:

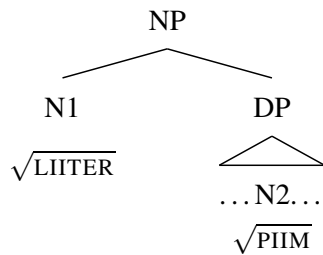

(414) Finnish:

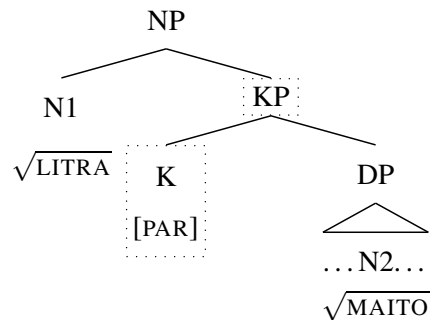

Because the partitive case in Finnish pseudopartitives is present from the outset, cases merged later (like inessive) cannot spread to the N2 phrase. Under the Unmarked Partitive hypothesis, case overwriting is unnecessary (and more strongly, prohibited).

This analysis also gives us a straightforward way to explain the historic divergence between Estonian and Finnish. Note that the structures in (413) and (414) are very similar, and

in nominative and accusative contexts, they lead to the same morphosyntactic output. The only evidence for differing analyses comes in the matching cases. Numeral-noun constructions have a similar morphosyntactic form (in the nominative and accusative); it stands to reason that speakers of Estonian began reanalyzing the partitive case in pseudopartitives to give it the same source as in numeral-noun constructions (Koptjevskaja-Tamm 2001). This reanalysis can be conceptualized as the removal of the KP layer from the N2 phrase.

4.8 Conclusions

In this chapter, I probed the limits of case concord in Estonian. The empirical focus was the pseudopartitive construction, which exhibits an alternation between apparent assignment of partitive case (= the partitive pattern) and case agreement (= the matching pattern).

(415) Estonian (Erelt et al. 1993b:144–145)

- a. [Kott kartule-id] hakka-s otsa saa-ma
 [bag.NOM potato-PL.PAR] begin-PST.3SG end get-MA
 ‘The bag of potatoes was starting to run out.’
- b. Kui palju sa [koti kartuli-te] eest mak-si-d?
 how much you.NOM [bag.GEN potato-PL.GEN] for pay-PST-2SG
 ‘How much did you pay for the bag of potatoes?’

The descriptive generalization is clear. If the entire pseudopartitive is in a nominative or accusative position, partitive surfaces on the N2 phrase (see (415a)). On the other hand, if the entire pseudopartitive is in a position where it will be marked with some other case, then both N1 and the N2 phrase bear that case-marking (see (415b)).

Formally speaking, two options present themselves at the moment. First, we could appeal to a stipulated case hierarchy that says that nominative and accusative are in some sense weaker than partitive and all the other cases are stronger. Whenever an element is in the domain of two different case assigners, then it expresses the strongest possible case. The trouble with such an account is that it does little more than move the question around. It leaves us wondering why the case hierarchy would be organized in that way. Estonian provides, to my mind, interesting evidence that the hierarchical effects cannot be derived from morphological properties of the particular case morphemes. The genitive and accusative are morphologically identical in some situations, yet they lead to different case patterns within pseudopartitives.

I then considered two possible ways of deriving the hierarchical facts from timing. The guiding intuition is that nominative and accusative are assigned too late to affect case-marking internal to the pseudopartitive. While both hypotheses could account for pseudopartitive and numeral-noun constructions on their own, they made divergent predictions about M-stacks, constructions involving a numeral-noun construction stacked on top of a pseudopartitive. The Phase-Based Spell-Out Analysis predicted that the most deeply embedded constituent (the N2 phrase) would be in partitive case invariantly. The Unmarked Partitive analysis predicts that M-stacks will show full case-matching. As we saw, the latter was true: M-stacks in matching case positions show full case-matching. The Unmarked Partitive analysis derives the hierarchical effects as a matter of timing: partitive is assigned too late to be assigned in the context of matching cases, and nominative and accusative are assigned too late to affect the partitive-marking inside the pseudopartitive.

The Unmarked Partitive analysis also raises a number of interesting questions. In Marantz's original formulation of dependent case assignment, (morphological) case assignment takes place in the morphological component. This means that, when the requisite syntactic structure is built for the assignment of a particular case, case assignment does not happen immediately. Instead, the grammar must wait until that structure is sent to the morphological component. However, recent analyses following Marantz's general research program (e.g., Baker & Vinokurova 2010, Levin & Preminger to appear, Poole 2014, Preminger 2011) assume that case is, in fact, assigned in the syntax, and furthermore, that case is assigned as soon as its structural description is met. In order for the Unmarked Partitive analysis to get off the ground, it must be true that some surface cases "wait" to be assigned. The Unmarked Partitive case cannot be assigned until the entire KP is built, as that is the information necessary to determine whether or not partitive can be assigned. Some of the above analyses treat default case (i.e., nominative) in this sort of "last resort" way, but if one adopts the kind of analysis that I advocate for Estonian partitive inside nominals, then it must be true for some other cases as well.

The Unmarked Partitive analysis suggests a fairly restricted view of structural case. Concretely, it suggests that *only* nominative and accusative are structural cases in Estonian. This is particularly interesting when considering genitive case. The suggestion is often made that genitive inside of DPs is a structural case, and the same could be true of the genitive case assigned by adpositions to their complements. However, as we have seen, pseudopartitives in these posi-

tions exclusively show the matching pattern. There are at least two clear paths forward. Along one path, we need to rethink the syntactic distinction between structural and inherent case. In this world, the fact that the assignment of such-and-such case is predictable is not a sufficient condition for treating it as structural case. Along another path, we might conclude that the syntactic and morphological components of the grammar do not cut the pie in the same way—perhaps some cases are structural as far as the syntax is concerned, but those same cases are grouped for morphological purposes with cases that are more clearly lexical/inherent. Either way, the data from pseudopartitives lend support to the idea that there is more than one way for an element to end up bearing morphological case.

Chapter 5

Conclusion

5.1 Summary of results

This dissertation presents a detailed theory of nominal concord as a morphological phenomenon in Estonian. Concord is traditionally described as “agreement with the head noun,” but the data from Estonian reveal that this is not the optimal formal analysis. The theory I propose instead is that concord is an indicator of *membership*: certain elements indicate their membership in a particular phrase by expressing features of that phrase. This draws a line, both formally and descriptively, between concord and subject-verb agreement. Though both may be termed *agreement*—but note that this depends on one’s definition of that term—I claim that concord is not the DP-internal correlate of subject-verb agreement, and neither is subject-verb agreement the CP correlate of concord.

The analysis of concord that I developed in this dissertation is based on the syntactic structure I developed for the Estonian DP in chapter 2, and this analysis led to a number of interesting conclusions about DP structure. First, I claimed that Estonian nominals are DPs despite the fact that the language has no articles. The results of that section thus serve as a counterproposal to the claim that nominals in languages without articles are not DPs (Bošković 2005, *et seq.*). I then turned to the syntax of cardinal numerals, ultimately arguing that there are two kinds of syntactic structures that can be occupied by cardinal numerals (Danon 2012). In one structure, the cardinal numeral is a head in the nominal extended projection. In the other, the cardinal numeral is the specifier of another functional head in the nominal extended projection.

In chapter 3, I proposed the core of the theory of nominal concord. The first piece is

that the various morphosyntactic features of DPs are made accessible throughout the DP. The second piece is that elements showing concord acquire the feature values they need to express from the closest source that has them. When there is only one value available for each feature, the result is apparent agreement with the head noun: everything showing concord expresses the same feature values, and those are the values of the noun as well. However, when more than one value is available for some feature or other, this no longer obtains. A word can be said to show concord without matching any of the features of the head noun.

This last point is particularly relevant when considering the system of case concord in the language as I did in chapter 4. Numeral-noun constructions and pseudopartitives both show an alternation in case-marking between what I called the partitive pattern, when structurally higher elements bear one case and structurally lower elements bear partitive case, and what I called the matching pattern, where every element bears the same case-marking. The partitive pattern only surfaces when the entire DP is in a position to be marked with either nominative or accusative case. Estonian is, to my knowledge, unique in that it shows this pattern in both numeral-noun constructions and pseudopartitives, which enables us to more deeply test the predictions of existing analyses of similar phenomena. I proposed that the partitive case assigned inside of DPs is an unmarked case. It does not surface in the matching pattern, because those cases are assigned before the unmarked partitive case comes into effect when the entire KP is built. Partitive case surfaces only in the context of nominative and accusative cases, because those cases are assigned after the unmarked partitive case comes into effect, i.e., when the DP/KP is merged with the clausal spine. Every element within DP “shows concord” in the same way in all cases; they just express different values.

Though the formalization proposed here is to my knowledge novel, the idea that concord is purely morphological has its roots in seminal work such as Anderson 1992, Gazdar et al. 1985, Pollard & Sag 1994. Interest in syntactic analyses of agreement has grown in recent years, and many of the modern analyses of concord have followed a similar trajectory. The analysis presented here takes a different tack, and in that sense, it serves in part as a proof of concept. However, I believe that the theory developed here also comes closer to capturing the true nature of concord in a simple manner. Once we adopt the assumption that ϕ -features and case features are not simply represented on one node in a DP but throughout the entire DP—an idea that has been around for several decades now and which may be independently necessary—then the

values that an element showing concord ultimately expresses can simply be determined based on the height of its merge position.

5.2 In search of verbal concord

In the world proposed in this dissertation, there are (at least) two distinct kinds of agreement. There is Agree-style agreement, between a functional head and a full DP. In the clausal domain, this is exemplified by agreement between T^0 and DP: subject-verb agreement, schematized in (416). In the nominal domain, this is exemplified by agreement between D^0 (or $Poss^0$) and DP: possessor agreement, schematized in (417).

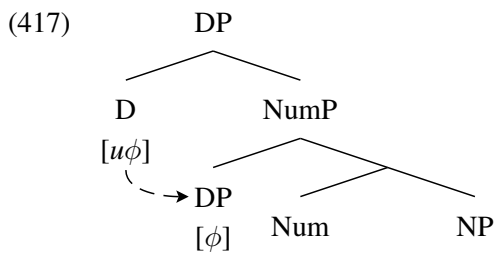
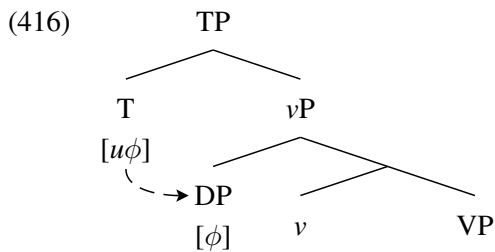

In both constructions, there is a high functional head with unvalued phi-features ($[u\phi]$): the probe. It establishes an Agree relationship with a DP in its c-command domain. This kind of probe-goal agreement thus exists in both TPs and DPs. That fact has been cited as evidence of a deep similarity between the structure of DP and the structure of TP.

This dissertation has argued for the existence of a different kind of agreement (concord-style agreement) within DP, and thus we should expect to find a correlate in CP/TP. Let us take a moment to recall the defining properties of nominal concord. In what I take to be the canonical case, nominal concord has the following properties.

1. It appears on **many elements** in one DP.

A similar example comes from Yidj, as described by Dixon (1977). There are some elements, which Dixon calls adverbs, that must inflect for verbal features.

- (419) a. η ayu $\dot{\text{c}}$ ugi warŋgiŋalŋu gunda:l
 I-SA tree-ABS do.all.round-COMIT-PAST cut-PAST
 ‘I cut all round the [trunk of the] tree.’ (Yidj) (Dixon 1977:253)
- b. mayi giḍa:na daŋga:na banam
 vegetable-ABS do.quickly-PURP take.out-PURP water-ABL
 ‘[We must] quickly take the vegetables out of the water.’ (Yidj) (Dixon 1977:253)

In (419), the underlined words bear inflection indicating certain features of the verbal extended projection. If these words can indeed be analyzed as adverbs, then these examples would also clearly meet criteria 2 and 3: they are marked on adverbs (criterion 2), and they involve verbal features (criterion 3). As with the last example, these do not clearly meet criterion 1.

5.2.2 Verbal concord with ϕ -features

If we expand the definition of verbal concord such that it includes multiple heads bearing ϕ -features, more possibilities surface. The ϕ -features of one of the arguments are not verbal features in the strictest sense, because they are not born there. However, it is commonplace for verbal functional heads to acquire nominal ϕ -features during the course of a derivation, so in that sense, it does not seem unreasonable that a process of verbal concord might manipulate ϕ -features instead of (or in addition to) features that are truly verbal.

5.2.2.1 Nakh-Dagestanian: verbal concord with subject ϕ -features

In a number of Nakh-Dagestanian languages, several words in the verbal extended projection must bear inflection indicating the noun-class features of the absolutive argument. Some examples from Archi are provided below.

- (420) to-r-mi b-ez χ^{r} oŋon au
 that.ONE-II.SG-ERG III.SG-1SG.DAT dress.III.SG.ABS <III.SG>make.PFV
 ‘She made me a dress.’ (Archi) (Radkevich & Polinsky 2013)

- (421) oq^ʃa-t:u-b balah dit:au
 <III.SG>leave.PFV-ATR-III.SG trouble.III.SG.ABS quickly<III.SG>
 b-erχin
 III.SG-forget-IPFV
 ‘Past trouble gets forgotten quickly.’ (Archi) (Radkevich & Polinsky 2013)
- (422) to-r d-aq^ʃa maʁa-k e<r>q^ʃen
 that-II.SG.ABS II.ABS-come.PFV magar-LAT <II.SG>up.to
 ‘She went up to the Magar village.’ (Archi) (Radkevich & Polinsky 2013)

In (420), the indirect object *bez* bears inflection *b-* indicating the noun class of the absolutive argument. Similar inflection is found on the adverb (underlined) in (421), and on the prepositional phrase (underlined) in (422).

This kind of agreement is termed EXUBERANT EXPONENCE by Harris (2009). Exuberant exponence exists in a number of Nakh-Dagestanian languages, as noted by Radkevich & Polinsky (2013). (See also Harris (2009) for a thorough discussion of the phenomenon in the Nakh language Batsbi). Exuberant exponence satisfies criterion 1 (many elements) and criterion 2 (many positions), but the features that are manipulated are not strictly speaking verbal features. This is perhaps not surprising, because the elements of the verbal extended projection come to bear arguments’ ϕ -features during the course of a syntactic derivation. If concord is morphological, as I have claimed, then the prediction is that some systems of verbal concord would involve the spread of ϕ -features among elements of the verbal extended projection. In that sense, the Nakh-Dagestanian languages represent a clear example of verbal concord.¹

5.2.2.2 Finnish & Estonian: verbal concord in imperatives

Another possible example of verbal concord is in the Finno-Ugric languages. In Finno-Ugric linguistics, negation is often described as a “verb,” as it is negation that bears agreement in negative clauses (Mitchell 2006). The main verb cannot bear agreement.²

¹The analysis that Radkevich & Polinsky (2013) propose is similar to the analysis of nominal concord I propose in that the elements bearing ϕ -features in Archi do not necessarily establish Agree relationships directly with the absolute argument. Instead, there are multiple v^0 heads in Archi, each establishing Agree with the either the absolutive argument or another v^0 that has. The features come to be marked on the various elements due to postsyntactic morphological processes.

²Estonian’s default negation marker is impoverished: it no longer shows agreement. However, neither does the main verb in negated clauses, so I assume, following Norris & Thompson 2014, that its lack of inflection is morphological in nature. In other words, the fact that the negation marker does not inflect in Estonian is not

(423) Finnish:

- a. (Me) em-me lue.
1PL NEG-1PL read
'We don't read.'
- b. E-n luke-nut.
NEG-1SG read-PST.PCPL
'I didn't read.'

(424) Estonian:

- a. Me ei loe.
1PL NEG read.
'We don't read.'
- b. Ma ei luge-nud.
1SG NEG read-PST.PCPL
'I didn't read.'

The potential case of verbal concord comes from negated imperatives. In negated imperatives, a different negation marker is used. This negation marker still bears agreement, but it is from a paradigm specific to the imperative forms in the language. In addition, the main verb also bears imperative morphology (in Finnish) and imperative agreement (in Estonian).

(425) Finnish (Sulkala & Karjalainen 1992):

- a. ÄI-kää tul-ko!
NEG-IMP.2PL come-IMP
'Don't come!'
- b. ÄI-kää-mme tul-ko!
NEG-IMP.2PL-1PL come-IMP
'Let's not come!'

(426) Estonian (Erelt et al. 1993b):

- a. Är-ge tul-ge!
NEG-IMP.2PL come-IMP.2PL
'Don't come!'
- b. Är-me tule(-me)!
NEG-IMP.1PL come-IMP.1PL
'Let's not come!'

necessarily evidence that the syntax of negation in Estonian is different than in Finnish.

In Finnish, both the negation marker and the the main verb inflect to reflect the imperativity of the clause. In Estonian, both negation and the main verb reflect imperativity and the subject's ϕ -features. This kind of example is reminiscent of serial verb constructions where both verbs must bear the same tense/aspect marking (Aikhenvald & Dixon 2006). These examples possibly meet criterion 1 (many elements) and criterion 3 (verbal features), but they do not obviously meet criterion 2 (many positions).

5.2.3 In search of verbal concord: summary

Of course, the discussion above is descriptive, and the question of whether or not these examples can be called verbal concord depends on the viability of such an *analysis*. In ongoing work with Anie Thompson, I (we) have proposed that the facts from Estonian imperatives are better explained as a kind of verbal concord as opposed to the reflex of multiple separate Agree relationships (Norris & Thompson 2014). If the view that I propose can be maintained, these are the kinds of cases that must be carefully investigated in order to better understand the kinds of agreement that we find in the world's languages.

However, this also raises some broader questions about the typology of agreement. For example, why are examples of verbal concord not more commonly found? For its part, nominal concord is quite well-known, and it also seems to be fairly common. Subject-verb agreement and possessor agreement, which are two sides of the same coin in the view sketched here (following Abney (1987), Szabolcsi (1983, 1994)), both exist in a number of different, unrelated language families. If it is indeed true that nominal concord is noticeably more common than verbal concord, it is worth seeking an explanation for why that should be the case. One possible line of attack is that there is some deep connection between nominal features and agreement which makes them more likely to be manipulated in agreement relations (see, for example, Gazdar et al. (1985), Keenan (1974)).

A related question concerns the way kinds of CP agreement and DP agreement are distributed in the languages of the world. For example, there are many languages with subject-verb agreement, but no possessor agreement. Estonian, Icelandic, and French are all examples of this. Instead, these languages (among many others) have one form of agreement in CPs and another form in DPs. These are opposed to languages that have subject-verb agreement in CPs and possessor agreement in DPs, such as the Mayan languages and the Turkic languages. These

languages thus have the same kind of agreement in CPs and DPs. Carstens (2000) notes this apparent dichotomy and suggests it is due to grammatical gender: languages that have grammatical gender have concord. However, the existence of concord in the Finno-Ugric languages, which have no grammatical gender system, suggests that this cannot be the whole story.

Furthermore, as we have seen, this is actually a false dichotomy. There are some Finno-Ugric languages with both possessor agreement and nominal concord, e.g., Finnish and Skolt Sami. Thus, possessor agreement and concord are not mutually exclusive. In the world sketched here, where concord is a distinct form of agreement, we expect to find languages where both kinds of nominal agreement coexist. That being said, there seem to be few such examples. I have no deep explanation for why that should be.

5.3 Next steps

Though there is more work to be done on Estonian concord itself, the clearest next steps are to investigate concord in other languages. To that end, in the final portion of this conclusion I raise some questions to consider with respect to the typology of concord.

5.3.1 Where to look for interesting data

In order to deepen our understanding of nominal concord, it is clear that we must look beyond the cases of simple concord: those situations when every element showing concord is bearing the same case and number values. These situations establish concord as a robust phenomenon, but they are not especially revealing about its nature. If a particular language only shows simple concord, then there are two places that come to mind as potentially revealing about the nature of concord.

First, the concord patterns of adjectives are worth investigating, especially in languages where attributive adjectives can take complements. In Estonian, what the facts reveal is that attributive adjectives *always* show concord with the head noun, no matter how much structure is present in the AP. The analysis that I propose predicts that the syntax of a particular element showing concord—e.g., whether or not it has a complement—does not affect whether or not it shows concord. Thus, if there is a language where bare adjectives—that is, A^0 heads that are both minimal and maximal—show concord, but adjectives with complements do not, that

would be interesting evidence against the theory that I have proposed.

Second, I believe DPs containing possessors could be revealing about the nature of concord within a language and crosslinguistically. In particular, it is worth investigating whether the features of the possessor affect the feature values expressed by the elements showing concord. In Estonian, they clearly do not, and the theory that I proposed does not allow them to do so, insofar as, by hypothesis, features do not percolate out of specifiers. This is complicated by the fact that in some languages, possessor agreement and concord co-exist within a single DP. How the grammar maintains and differentiates the feature sets of possessors and possessa is a theoretical problem that is worth thinking very carefully about.³ I addressed this possible issue by proposing that elements showing concord acquire their features from sources that *include*⁴ them. Because possessors occupy specifier positions in Estonian, they will never be in the proper position to pass their features to elements showing concord in the possessum DP.

5.3.2 Optional concord

In Estonian, as in many other languages, concord is obligatory. However, a complete theory of concord must allow for concord to be optional in some cases. For example, as I mentioned briefly in chapter 3, case concord in Nez Perce is optional (Deal 2010:33). Some near minimal pairs are presented below.

- (427) a. 'e-pewi-tx yoosyoos wixsilikeecet'es-ne
 3OBJ-look.for-IMPER.PL blue chair-OBJ
 'Look for the blue chair!' (Nez Perce) (Deal 2010:33)
- b. 'e-pewi-se yoosyoos-na wixsilikeecet'es-ne
 3OBJ-look.for-IMPERF blue-OBJ chair-OBJ
 'I am looking for the blue chair.' (Nez Perce) (Deal 2010:33)

³This is especially true in light of the possible examples of concord in CP discussed above that involve manipulation of ϕ -features. If concord in CP can involve “borrowed” features (i.e., features that originate outside of CP), we would expect that concord in DP could do the same.

One possible example of this phenomenon comes from Hiaki, where D^0 typically agrees in number with the noun, but if there is an intervening possessor, it agrees with that possessor instead (Harley & Trueman 2011). It is interesting that this head is D^0 , which is a head that we already know to serve as a probe in other languages.

⁴This is inclusion in the technical sense: formal domination except in the case of adjuncts, where domination and inclusion come apart formally (see Chapter 1).

- (428) a. *lepít lehey-pe hi-weqí-se-ne*
 two day-LOC 3SUBJ-rain-IMPERF-REM.PAST
 ‘Two days ago it rained.’ (Nez Perce) (Deal 2010:34)
- b. *lepít-ípe lehey-pe hi-lati-ca-na*
 two-LOC day-LOC 3SUBJ-flower-IMPERF-REM.PAST
 ‘Two days ago it was flowering.’ (Nez Perce) (Deal 2010:33)

Example (427) shows case concord with the adjective *yoosyoos* ‘blue’. The adjective is marked for objective case in (427b); it is not marked for objective case in (427a). Similar facts are shown for the numeral *lepít* ‘two’ in (428). Case concord is also optionally present on demonstratives and possessors, but I forego examples here.⁵ Under the theory developed here, I suggested that this optionality must be a part of the Agr⁰ node insertion operation. Concretely, in Nez Perce, Agr⁰ nodes for case are only optionally inserted (see Kramer 2010 for optional Agr⁰ node insertion in an analysis of adjectival definiteness agreement).

Quite interestingly, concord in number in Nez Perce does not seem to be optional to the same degree. In fact, Deal (2013a) uses number concord on adjectives to detect number features of nouns that themselves are never marked for plural. For example, inanimate nouns do not bear overt plural-marking in Nez Perce, but adjectives still do.

- (271) *ki-kuhet tí-yaw’íc wíxsi’likeecet’es*
 PL-tall PL-sturdy chair
 ‘tall, sturdy chairs’ (Deal 2013a:8)

However, Deal (2013a) indicates a “small degree of optionality” in number concord (pp. 17–18). The fact that all forms of concord in Nez Perce show optionality to some degree raises a number of questions. These questions are tied up in the nature of concord more generally. There is one sense in which the Nez Perce system is well-behaved: every feature involved in concord shows some amount of optionality. On the other hand, they do not appear to be optional to the same degree. In investigating cases of optional concord, we might wonder whether concord (for some feature) is optional for some categories but not others. Given the head-driven approach to Agr⁰ node insertion that I have pursued, I certainly predict such a case to be true. We might also imagine a system in which concord for some features is optional (e.g., [CASE]) is optional, but concord for other features (e.g., [NUMBER]) is not. Nez Perce approximates this system, as

⁵Nez Perce concord in gender (i.e., the feature [HUMAN]) is also optional (Amy Rose Deal, pc). This issue is not raised in Deal 2013a, so I forego examples here.

case concord in Nez Perce is more clearly optional than number concord (Amy Rose Deal, pc).

The broader questions connected to optionality have to do with its frequency. Can it be said that concord (when it exists) is generally obligatory? Are there some features that are more regularly optional than others? I am not suggesting that the answers to these questions will necessarily need to be explained by some core property of the grammar. Rather, they are worth investigating insofar as concord is worth investigating. In order to answer these questions, we must continue to take concord very seriously as a robust and interesting area for study.

5.4 Final remarks

The results of this dissertation bear directly on debates concerning case-marking and agreement, two phenomena located squarely on the border of syntax and morphology. With respect to case-marking, much of the research on case-marking has focused on the ways in which case can be assigned and realized. The results of this dissertation provide support to the idea that there are some cases that are not assigned by particular heads; rather, they are syntactic defaults. The data considered here also shed light on the divide between structural and inherent case. For their different behavior in Estonian nominals, I proposed an explanation in terms of timing: nominative and accusative are assigned later than the default partitive rule is applied.

With respect to agreement, the view that emerges from this work is that morphological agreement is a formally heterogeneous group (see also Anderson (1992)). In other words, it is not the case that all phenomena that we might term *agreement* are formally the same. In particular, I argued that nominal concord must be formally distinguished from subject-verb agreement. Whereas subject-verb agreement has been argued to be dependent on a deeply syntactic relationship, I have proposed that concord is essentially morphological. Yet, this investigation was based primarily on one language, and as I noted in Chapter 1, concord is attested in many language families across the world. My hope is that this dissertation will serve as a springboard for further work on this particular understudied subpart of agreement phenomena. These kinds of investigations will be crucial as we continue to develop our understanding of the syntax-morphology interface.

Bibliography

- Abels, Klaus & Ad Neeleman. 2012. Linear asymmetries and the LCA. *Syntax* 15(1). 25–74.
- Abney, Steven Paul. 1987. *The English noun phrase in its sentential aspect*: Massachusetts Institute of Technology dissertation.
- Abondolo, Daniel (ed.). 1998. *The Uralic Languages*. New York: Routledge.
- Aikhenvald, Alexandra Y. & Robert M.W. Dixon. 2006. *Serial verb constructions: A cross-linguistic typology*. Oxford: Oxford University Press.
- Alexiadou, Artemis & Elena Anagnostopoulou. 2006. From hierarchies to features: person splits and direct-inverse alternations. In Cedric Boeckx (ed.), *Agreement systems*, 41–62. Amsterdam: John Benjamins.
- Alexiadou, Artemis, Liliane Haegeman & Melita Stavrou. 2007. *Noun phrase in the generative perspective*. New York: Mouton.
- Anagnostopoulou, Elena. 2005. Strong and weak person restrictions: A feature checking analysis. In L. Heggie & Ordóñez (eds.), *Clitic and affix combinations*, 199–235. Amsterdam: John Benjamins.
- Anderson, Stephen. 1992. *A-morphous Morphology*. Cambridge: CUP.
- Anderson, Stephen R. 1982. Where's morphology? *Linguistic inquiry* 571–612.
- Babby, Leonard. 1987. Case, prequantifiers, and discontinuous agreement in Russian. *Natural Language & Linguistic Theory* 5(1). 91–138.
- Babby, Leonard. 2009. *The syntax of argument structure*, vol. 120. Cambridge University Press.
- Babby, Leonard H. 1984. Case conflicts and their resolution: a contribution to EST case theory. In Wayne Harbert (ed.), *Cornell working papers in linguistics*, vol. 6, 1–21. Cornell University.
- Baker, Mark. 2008. *The Syntax of Agreement and Concord*. Cambridge: CUP.
- Baker, Mark & Ruth Kramer. To Appear. Rethinking Amharic prepositions as case markers inserted at PF. *Lingua* .

- Baker, Mark & Nadya Vinokurova. 2010. Two modalities of case assignment: case in Sakha. *Natural Language & Linguistic Theory* 28(3). 593–642.
- Baker, Mark & Willie Udo Willie. 2010. Agreement in ibibio: From every head to every head. *Syntax* 13(2). 99–132.
- Barker, Chris. 1995. *Possessive descriptions*. Stanford University: CSLI Publications.
- Battye, Adrian. 1991. Partitive and pseudo-partitive revisited: Reflections on the status of ‘de’ in French. *Journal of French Language Studies* 1(1). 21–43.
- Bauer, Winifred. 1993. *Maori Descriptive Grammars Series*. Routledge.
- Beard, R. 1966. *The suffixation of adjectives in contemporary literary Serbo-Croatian*: University of Michigan dissertation.
- Béjar, Susana & Milan Rezac. 2009. Cyclic agree. *Linguistic Inquiry* 40(1). 35–73.
- Belletti, Adriana. 1988. The case of unaccusatives. *Linguistic inquiry* 19(1). 1–34.
- Bernstein, Judith. 1993. *Topics in the syntax of nominal structure across Romance*: CUNY dissertation.
- Bhatt, Rajesh. 2005. Long distance agreement in Hindi-Urdu. *Natural Language & Linguistic Theory* 23(4). 757–807.
- Bittner, Maria & Ken Hale. 1996. The structural determination of case and agreement. *Linguistic Inquiry* 27(1). 1–68.
- Blevins, James P. 2008. Declension classes in Estonian. *Linguistica Uralica* XLIV. 241–267.
- Bobaljik, Jonathan David. 2008. Where’s Phi? Agreement as a Post-Syntactic Operation. In Daniel Harbour, David Adger & Susana Béjar (eds.), *Phi Theory: Phi-features across interfaces and modules*, 295–328. Oxford: Oxford University Press.
- Borer, Hagit. 1984. *Parametric syntax: case studies in semitic and romance languages*. Dordrecht: Foris.
- Borer, Hagit. 2005. *Structuring sense, volume I: In name only*. Oxford: Oxford University Press.
- Bošković, Željko. 2005. On the locality of left branch extraction and the structure of NP. *Studia linguistica* 59(1). 1–45.
- Bošković, Željko. 2006. Case and agreement with genitive of quantification in Russian. In Cedric Boeckx (ed.), *Agreement systems*, 99–121. Amsterdam/Philadelphia: John Benjamins.
- Bošković, Željko. 2008. What will you have, DP or NP? In *Proceedings of the North East Linguistic Society* 37, 101–114. GLSA, University of Massachusetts, Amherst.

- Bošković, Željko. 2009. More on the no-DP analysis of article-less languages. *Studia Linguistica* 63(2). 187–203.
- Bošković, Željko. 2012. On NPs and clauses. In G. Grewendorf & T. E. Zimmerman (eds.), *Discourse and grammar: From sentence types to lexical categories*, 179–242.
- Brattico, Pauli. 2008. Kayne's model of Case and Finnish nominal phrases. *Nordic Journal of Linguistics* 31. 135–160.
- Brattico, Pauli. 2010. The two-part models and one-part models of nominal case, evidence from case distribution. *Journal of Linguistics* 45. 47–81.
- Brattico, Pauli. 2011. Case assignment, case concord, and the quantificational case construction. *Lingua* 121. 1042–1066.
- Bruening, Benjamin. Under review. Defects of defective intervention. ms, University of Delaware.
- Brugè, L. 2002. The positions of demonstratives in the extended nominal projection. In Guglielmo Cinque (ed.), *Functional structure in DP and IP: the cartography of syntactic structures*, 15–53. New York: Oxford University Press.
- Cable, Seth. 2007. *The grammar of Q: Q-particles and the nature of wh-fronting*: Massachusetts Institute of Technology dissertation.
- Caha, Pavel. 2009. *The nanosyntax of case*: Universitet i Tromsø dissertation.
- Caha, Pavel. 2013. Explaining the structure of case paradigms by the mechanisms of nanosyntax: The Classical Armenian nominal declension. *Natural Language & Linguistic Theory* 31. 1015–1066.
- Carstens, Vicki. 1991. *The morphology and syntax of determiner phrases in kiswahili*: University of California, Los Angeles dissertation.
- Carstens, Vicki. 2000. Concord in minimalist theory. *Linguistic Inquiry* 31(2). 319–355.
- Carstens, Vicki. 2001. Multiple agreement and case deletion: Against φ -incompleteness. *Syntax* 4(3). 147–163.
- Carstens, Vicki. 2011. Hyperactivity and hyperagreement in Bantu. *Lingua* 121(5). 721–741.
- Carstens, Vicki. 2013. Delayed Valuation: a reanalysis of "upwards" complementizer agreement and the mechanics of Case. ms., University of Missouri.
- Cheng, Lisa Lai-Shen & Rint Sybesma. 2012. Classifiers and DP. *Linguistic inquiry* 43(4). 634–650.
- Chomsky, Noam. 1965. *Aspects of the theory of syntax*. Cambridge, MA: MIT Press.

- Chomsky, Noam. 1981. *Lectures in Government and Binding: The Pisa Lectures*. Foris, Dordrecht.
- Chomsky, Noam. 1986. *Barriers*. Cambridge, MA: MIT Press.
- Chomsky, Noam. 1995. *The minimalist program*. MIT press.
- Chomsky, Noam. 2000. Minimalist inquiries: the framework. In Roger Martin, David Michaels & Juan Uriagereka (eds.), *Step by step: Essays on minimalism in honor of Howard Lasnik*, 89–156. Cambridge: MIT Press.
- Chomsky, Noam. 2001. Derivation by Phase. In Michael Kenstowicz (ed.), *Ken Hale: A Life in Language*, 1–52. Cambridge: MIT Press.
- Chomsky, Noam. 2008. On phases. In R. Freidin, C. Otero & M.L. Zubizarreta (eds.), *Foundational issues in linguistic theory: Essays in honor of Jean-Roger Vergnaud*, Cambridge, MA: MIT Press.
- Chung, Sandra. 2013. The syntactic relations behind agreement. In Lisa Lai-Shen Cheng & Norbert Corver (eds.), *Diagnosing syntax*, Oxford: Oxford University Press.
- Chung, Sandra. To Appear. On reaching agreement late. In *CLS 48: Papers from the parasessions*, Chicago: Chicago Linguistic Society.
- Cinque, Guglielmo. 1994. On the evidence for partial N-movement in the Romance DP. In Guglielmo Cinque (ed.), *Paths towards universal grammar*, 85–110. Washington, D.C.: Georgetown University Press.
- Cinque, Guglielmo. 2005. Deriving Greenberg's universal 20 and its exceptions. *Linguistic inquiry* 36(3). 315–332.
- Coon, Jessica. 2009. Interrogative possessors and the problem with pied-piping in Chol. *Linguistic Inquiry* 40. 165–175.
- Copetake, Ann & Ted Briscoe. 1995. Semi-productive polysemy and sense extension. *Journal of semantics* 12(1). 15–67.
- Coppock, Elizabeth & Stephen Wechsler. 2012. The objective conjugation in Hungarian: agreement without phi-features. *Natural Language & Linguistic Theory* 1–42.
- Corbett, Greville. 1991. *Gender*. Cambridge: CUP.
- Corbett, Greville. 2006. *Agreement*. Cambridge: CUP.
- Corver, Norbert. 1992. Left branch extraction. In *Proceedings of nels*, vol. 22, 67–84.
- Corver, Norbert & Joost Zwarts. 2006. Prepositional numerals. *Lingua* 116(6). 811–835.
- Csirmaz, Aniko. 2012. The case of the divisible phase: Licensing partitive case in Finnish. *Syntax* 15(3). 215–252.

- Danon, Gabi. 2011. Agreement and DP-internal feature distribution. *Syntax* 14(4). 297–317.
- Danon, Gabi. 2012. Two structures for numeral-noun constructions. *Lingua* 122. 1282–1307.
- Dayal, Veneeta. 2004. Number marking and (in) definiteness in kind terms. *Linguistics and philosophy* 27(4). 393–450.
- Deal, Amy Rose. 2010. *Topics in the Nez Perce verb*: University of Massachusetts Amherst dissertation.
- Deal, Amy Rose. 2013a. Apportionment and the mass-count distinction in Nez Perce. ms, UCSC.
- Deal, Amy Rose. 2013b. Possessor raising. *Linguistic Inquiry* 44. 391–432.
- Déchaine, Rose-Marie & Martina Wiltschko. 2002. Decomposing pronouns. *Linguistic Inquiry* 33(3). 409–442.
- Delsing, Lars-Olof. 1993. *The internal structure of noun phrases in the Scandinavian languages*: University of Lund dissertation.
- Despić, Miloje. 2011. *Syntax in the absence of determiner phrase*: University of Connecticut dissertation.
- Despić, Miloje. 2013. Binding and the Structure of NP in Serbo-Croatian. *Linguistic Inquiry* 44(2). 239–270.
- Despić, Miloje. To Appear. Phases, reflexives, and definiteness. *Syntax* .
- Dixon, R. M. W. 1977. *A grammar of Yidj*. Cambridge: Cambridge University Press.
- Dobrovie-Sorin, Carmen & Ion Giurgea. 2011. Pronominal possessors and feature uniqueness. *Language* 87(1). 126–157.
- Dryer, Matthew S. 1992. The Greenbergian word order correlations. *Language* 68. 81–138.
- Dubinsky, Stanley & Mila Tasseva-Kurktchieva. 2014. On the NP/DP language frontier: Bulgarian as a transitional case. Poster presented at the 88th LSA Annual meeting, 2–5 January, 2014.
- Ehala, Martin. 1994. Russian influence and the change in progress in the Estonian adpositional system. *Linguistica Uralica* 30(3). 177–193.
- Einarsson, Stefán. 1949. *Icelandic: Grammar, Texts, and Glossary*. The Johns Hopkins Press.
- Embick, David. 1997. *Voice and the interfaces of syntax*: University of Pennsylvania dissertation.
- Embick, David. 2010. *Localism versus globalism in morphology and phonology*. MIT Press.

- Embick, David & Alec Marantz. 2008. Architecture and blocking. *Linguistic Inquiry* 39(1). 1–53.
- Embick, David & Rolf Noyer. 2001. Movement operations after syntax. *Linguistic Inquiry* 32(4). 555–595.
- Erelt, Mati. 1986. *Eesti adjektiivisüntaks (The syntax of adjectives in Estonian)*, vol. 19 Ema-keele Seltsi toimetised. Tallinn: Valgus.
- Erelt, Mati. 1999. Agreement in Estonian. In Mati Erelt (ed.), *Estonian: Typological Studies III*, 7–46. Tartu: Tartu University Press.
- Erelt, Mati. 2009. Typological overview of Estonian syntax. *STUF-Language Typology and Universals* 62(1-2). 6–28.
- Erelt, Mati, Tiiu Erelt & Kristiina Ross. 2000. *Eesti keele käsiraamat* [Estonian language handbook]. Tallinn: Eesti keele sihtasutus.
- Erelt, Mati, Reet Kasik, Helle Metslang, Henno Rajandi, Kristiina Ross, Henn Saari, Kaja Tael & Silvi Vare. 1993a. *Eesti Keele Grammatika I: Morfoloogia, Sõnamoodustus* [Estonian Grammar I: Morphology, Derivation]. Tallinn, Estonia: Eest Teaduste Akadeemia Keele ja Kirjanduse Instituut.
- Erelt, Mati, Reet Kasik, Helle Metslang, Henno Rajandi, Kristiina Ross, Henn Saari, Kaja Tael & Silvi Vare. 1993b. *Eesti Keele Grammatika II: Süntaks; Lisa: Kiri* [Estonian Grammar II: Syntax; Appendix: Written Language]. Tallinn, Estonia: Eest Teaduste Akadeemia Keele ja Kirjanduse Instituut.
- Farkas, Donka & Henriëtte de Swart. 2010. The semantics and pragmatics of plurals. *Semantics and Pragmatics* 3. 1–54.
- Feist, Timothy. 2010. *A grammar of Skolt Saami*: University of Manchester dissertation.
- Frampton, John & Sam Gutmann. 2006. How sentences grow in the mind: Agreement and selection in efficient minimalist syntax. In Cedric Boeckx (ed.), *Agreement systems*, 121–157. Amsterdam: John Benjamins Publishing Company.
- Franks, Steven. 1994. Parametric properties of numeral phrases in Slavic. *Natural Language and Linguistic Theory* 12. 597–674.
- Frisson, Steven & Lyn Frazier. 2005. Carving up word meaning: Portioning and grinding. *Journal of Memory and Language* 53(2). 277–291.
- Gazdar, Gerald, Ewan Klein, Geoffrey Pullum & Ivan Sag. 1985. *Generalized phrase structure grammar*. Harvard University Press: Cambridge, MA.
- Gillon, Carrie & Solveiga Armoskaite. 2012. The semantic import of (c)overt D. In *Proceedings of the 29th west coast conference on formal linguistics*, Somerville, MA: Cascadilla Proceedings Project.

- Gillon, Carrie & Solveiga Armoskaite. To Appear. The illusion of the NP/DP divide. *Studia Linguistica* .
- Giorgi, Alessandra & Giuseppe Longobardi. 1991. *The syntax of noun phrases*. Cambridge: Cambridge University Press.
- Giusti, Giuliana. 1997. The categorial status of determiners. *The new comparative syntax* 95–123.
- Greenberg, Joseph H. 1963. Some universals of grammar with particular reference to the order of meaningful elements. In Joseph Greenberg (ed.), *Universals of language*, 73–113. Cambridge, MA: MIT Press.
- Grimshaw, Jane. 1991/2005. *Words and structure*. CSLI Publications.
- Grimshaw, Jane. 2007. Boxes and piles and what's in them: two extended projections or one? In Annie Zaenen, Jane Simpson, Tracy Holloway King, Jane Grimshaw, Joan Maling & Chris Manning (eds.), *Architectures, rules, and preferences: Variations on themes by Joan W. Bresnan*, Stanford, CA: CSLI Publications.
- Halle, M. 1990. An approach to morphology. In *Proceedings of nels 20*, 150–184. University of Massachusetts, Amherst: GLSA.
- Halle, Morris & Alec Marantz. 1993. Distributed Morphology and the Pieces of Inflection. In K. Hale & S. J. Keyser (eds.), *The View from Building 20: Essays in Linguistics in Honor of Sylvain Bromberger*, 111–176. Cambridge, MA: MIT Press.
- Hankamer, Jorge. 1977. Multiple analyses. In Charles N. Li (ed.), *Mechanisms of syntactic change*, 583–607. Austin, TX: University of Texas Press.
- Hankamer, Jorge & Line Mikkelsen. 2008. Definiteness marking and the structure of Danish pseudopartitives. *Journal of Linguistics* 44(02). 317–346.
- Harizanov, Boris. 2011. NonInitiality within Spell-Out Domains: Unifying the Post-Syntactic Behavior of Bulgarian Dative Clitics. In Nicholas LaCara, Anie Thompson & Matthew Tucker (eds.), *Morphology at Santa Cruz*, Santa Cruz, CA: Linguistics Research Center.
- Harizanov, Boris. 2014. *On the mapping from syntax to morphophonology*: University of California, Santa Cruz dissertation.
- Harley, Heidi & Alex Trueman. 2011. Case and number dissociation in Hiaki. Handout of a talk given at the SSILA summer meeting, July 31, 2011.
- Harris, Alice C. 2009. Exuberant exponence in batsbi. *Natural Language & Linguistic Theory* 27(2). 267–303.
- Heck, Fabian. 2004. *A theory of pied-piping*: Universität Tübingen dissertation.
- Henderson, Brent. 2006. Multiple agreement and inversion in bantu. *Syntax* 9(3). 275–289.

- Hiietam, Katrin. 2003. *Definiteness and Grammatical Relations in Estonian*: University of Manchester dissertation.
- Hiietam, Katrin & Kersti Börjars. 2003. The emergence of a definite article in Estonian. In Diane Nelson & Satu Manninen (eds.), *Generative Approaches to Finnic and Saami Linguistics*, Stanford: CSLI Publications.
- Hiraiwa, Ken. 2000. Multiple agree and the defective intervention constraint in Japanese. *MIT working papers in linguistics* 40(40). 67–80.
- Horrocks, Geoffrey & Melita Stavrou. 1987. Bounding theory and Greek syntax: Evidence for wh-movement in NP. *Journal of Linguistics* 23. 79–108.
- Ionin, Tania & Ora Matushansky. 2004. A Singular Plural. In *Proceedings of the west coast conference on formal linguistics*, vol. 23, .
- Ionin, Tania & Ora Matushansky. 2006. The composition of complex cardinals. *Journal of Semantics* 23(4). 315–360.
- Jackendoff, Ray. 1977. *X-bar syntax*. Cambridge, MA: MIT Press.
- Julien, Marit. 2005. *Nominal phrases from a Scandinavian perspective*. John Benjamins Publishing Company.
- Kaplinski, Jaan. 1977. *Udujutt*. Tallinn: Eesti Raamat.
- Kayne, Richard. 1994. *The antisymmetry of syntax*. Cambridge, MA: MIT Press.
- Keenan, Edward L. 1974. The functional principle: generalizing the notion of ‘subject of’. In Michael W La Galy, Robert A Fox & Anthony Bruck (eds.), *Papers from the 10th regional meeting of the Chicago Linguistics Society*, 298–309.
- Kehayov, Petar & Virve Vihman. 2013. The lure of lability: A synchronic and diachronic investigation of the labile pattern in Estonian. ms, Tartu Ülikool.
- Kiparsky, Paul. 1998. Partitive case and aspect. In Miriam Butt & Wilhelm Geuder (eds.), *Projecting from the lexicon*, Stanford, CA: CSLI.
- Kiparsky, Paul. 2001. Structural case in Finnish. *Lingua* 111(4). 315–376.
- Kishimoto, Hideki. 2000. Indefinite pronouns and overt N-raising. *Linguistic Inquiry* 31(3). 557–566.
- Koopman, Hilda. 2006. Agreement configurations: in defense of “Spec Head”. In Cedric Boeckx (ed.), *Agreement systems*, 159–199. Amsterdam: Benjamins.
- Koptjevskaja-Tamm, Maria. 1993. *Nominalizations*. New York: Routledge.

- Koptjevskaja-Tamm, Maria. 2001. 'A piece of the cake' and 'a cup of tea': Partitive and pseudo-partitive nominal constructions in the Circum-Baltic languages. In Östen Dahl & Maria Koptjevskaja-Tamm (eds.), *The Circum-Baltic languages: Typology and contact*, vol. 2, 523–568.
- Kornfilt, Jaklin. 1997. *Turkish*. London: Routledge.
- Koskinen, Päivi. 1999. Syntactic category changing in syntax: Evidence from Finnish participle constructions. *Revue québécoise de linguistique* 27(2). 131–166.
- Kramer, Ruth. 2009. *Definite markers, phi-features, and agreement: a morphosyntactic investigation of the Amharic DP*: University of California, Santa Cruz dissertation.
- Kramer, Ruth. 2010. The Amharic definite marker and the syntax-morphology interface. *Syntax* 13. 196–240.
- Kramer, Ruth. 2012. A split analysis of plurality: evidence from Amharic. In Nathan Arnett & Ryan Bennett (eds.), *The proceedings of wccfl 30*, 226–236. Somerville, MA: Cascadilla Press.
- Ladusaw, William. 1982. Semantic constraints on the English partitive construction. In *Proceedings of the 1st west coast conference on formal linguistics*, 231–242. CSLI: Stanford.
- Lamontagne, Greg & Lisa Travis. 1987. The syntax of adjacency. In *Proceedings of the west coast conference on formal linguistics*, vol. 6, 173–186. Stanford: CSLI Publications.
- Langr, Kathleen. 2014. Possessive structures as evidence for DP in West Greenlandic. Handout of a talk given at BLS 40, February 8, 2014.
- Larson, Richard K & Franc Marušič. 2004. On indefinite pronoun structures with APs: Reply to Kishimoto. *Linguistic Inquiry* 35(2). 268–287.
- Levin, Theodore & Omer Preminger. to appear. Case in Sakha: Are Two Modalities Really Necessary? *Natural Language & Linguistic Theory* .
- Lieber, Rochelle. 1989. On percolation. *Yearbook of morphology* 2. 95–138.
- Löbel, Elisabeth. 1989. Q as a functional category. In Christa Bhatt, Elisabeth Löbel & Claudia Maria Schmidt (eds.), *Syntactic phrase structure phenomena in noun phrases and sentences*, 133–157. Amsterdam: John Benjamins.
- Löbner, Sebastian. 1985. Definites. *Journal of semantics* 4(4). 279–326.
- Longobardi, Giuseppe. 2001. The structure of DPs: Some principles, parameters, and problems. *The handbook of contemporary syntactic theory* 562–603.
- Lyons, Christopher. 1999. *Definiteness*. Cambridge: Cambridge University Press.

- Mallen, Enrique. 1997. A minimalist approach to concord in noun phrases. *Theoretical Linguistics* 23(23). 49–77.
- Marantz, Alec. 1991. Case and Licensing. In German Westphal, Benjamin Ao & Hee-Rahk Chae (eds.), *Proceedings of the 8th Eastern States Conference on Linguistics (ESCOL)*, .
- Martí Girbau, Núria. 2010. *The syntax of partitives*: Universitat Autònoma de Barcelona dissertation.
- Matthewson, Lisa. 2001. Quantification and the nature of crosslinguistic variation. *Natural Language Semantics* 9(2). 145–189.
- Matushansky, Ora. 2006. Head movement in linguistic theory. *Linguistic Inquiry* 37(1). 69–109.
- Matushansky, Ora. 2008. A case study of predication. In F. Marušič & R. Žauver (eds.), *Studies in formal slavic linguistics: Contributions from formal description of slavic languages 6.5*, 213–239. Frankfurt am Main: Peter Lang.
- Matushansky, Ora. 2009. Gender confusion: It's not (just) about sex. Handout of a talk given at Diagnosing Syntax, January 29-31, 2009.
- May, Robert. 1985. *Logical form: Its structure and derivation*. Cambridge, MA: MIT Press.
- McGinnis, Martha. 1998. *Locality in A-movement*: Massachusetts Institute of Technology dissertation.
- Merchant, Jason. To appear. How much context is enough? Two cases of span-conditioned stem allomorphy. *Linguistic Inquiry* .
- Miljan, Merilin. 2008. *Grammatical case in Estonian*: University of Edinburgh dissertation.
- Mitchell, Erika. 2006. The morpho-syntax of negation and the positions of NegP in the Finno-Ugric languages. *Lingua* 116(3). 228–244.
- Mürk, Harri. 1981. The grade alternation system in Estonian morphophonology. ms.
- Mürk, Harri. 1991. *The structure and development of Estonian morphology*, vol. 2. Indiana University.
- Mürk, Harri. 1997. *A Handbook of Estonian: Nouns, Adjectives, and Verbs*. Bloomington: Indiana University.
- Nelson, Diane & Ida Toivonen. 2000. Counting and the grammar: case and numerals in Inari Sami. *Leeds Working Papers in Linguistics* 8. 179–192.
- Nemvalts, Peep. 1996. *Case Marking of Subject Phrases in Modern Standard Estonian*. Stockholm: Almquist & Wiksell International.
- Nevins, Andrew. 2007. The representation of third person and its consequences for person-case effects. *Natural Language & Linguistic Theory* 25(2). 273–313.

- Nevins, Andrew. 2011. Multiple agree with clitics: person complementarity vs. omnivorous number. *Natural Language & Linguistic Theory* 29(4). 939–971.
- Nevis, Joel. 1984. A non-endoclititic in Estonian. *Lingua* 64(2). 209–224.
- Nevis, Joel. 1986. The comitative, terminative, abessive and essive as clitics in Estonian. *Ural-Altische Jahrbücher* 7. 79–98.
- Nikanne, Urpo. 1993. On Assigning Semantic Cases in Finnish. *Case and other functional categories in Finnish syntax* 75.
- Norris, Mark. 2012. Towards an analysis of Concord (in Icelandic). In *Proceedings of the 29th west coast conference on formal linguistics*, 205–213. Somerville, MA: Cascadilla Proceedings Project.
- Norris, Mark, Line Mikkelsen & Jorge Hankamer. to appear. Licensing Trouble. *Linguistic Inquiry*.
- Norris, Mark & Anie Thompson. 2014. Multiple agreement in Estonian imperatives. Poster presented at the Linguistic Society of America Annual Meeting, Minneapolis, MN, January 2–5, 2014.
- Noyer, Rolf. 1997. *Features, positions and affixes in autonomous morphological structure*. New York, NY: Garland Publishing.
- Ortmann, Albert. 2000. Where plural refuses to agree: feature unification and morphological economy. *Acta Linguistica Hungarica* 47(1-4). 249–288.
- Ouwayda, Sarah. 2013. Where Plurality Is: Agreement and DP Structure. In Stefan Keine & Shayne Sloggett (eds.), *Proceedings of the 42nd Annual Meeting of the North East Linguistic Society*, Amherst, MA: GLSA Publications.
- Pajusalu, Renate. 1997. Is there an article in (spoken) Estonian? In Mati Ereht (ed.), *Estonian: Typological Studies II*, Tartu: Tartu University Press.
- Pajusalu, Renate. 2000. Indefinite determiners *iiks* and *mingi* in Estonian. In Mati Ereht (ed.), *Estonian: Typological Studies IV*, Tartu: Tartu University Press.
- Pereltsvaig, Asya. 2006. Passing by cardinals: in support of head movement in nominals. In J. Lavine, S.L. Franks, M. Tasseva-Kurktchieva & H. Filip (eds.), *Formal approaches to slavic linguistics 14: The princeton meeting*, 277–292. Ann Arbor, MI: Michigan Slavic Publications.
- Pereltsvaig, Asya. 2007. The universality of DP: A view from Russian. *Studia linguistica* 61(1). 59–94.
- Pereltsvaig, Asya. 2013. Noun phrase structure in article-less Slavic languages: DP or not DP? *Language and Linguistics Compass* 7(3). 201–219.

- Perlmutter, David M. 1970. On the article in English. In Manfred Bierwisch & Karl Heidolph (eds.), *Progress in linguistics*, 233–248. The Hague: Mouton.
- Pesetsky, David. 2011. Dependent case as binding theory. Handout of a keynote address delivered at NELS 42, November 11, 2011.
- Pesetsky, David. 2013. *Russian Case Morphology and the Syntactic Categories*. Cambridge, MA: MIT Press.
- Pesetsky, David & Esther Torrego. 2007. The syntax of valuation and the interpretability of features. In S. Karimi, V. Samiian & W. K. Wilkins (eds.), *Phrasal and clausal architecture: Syntactic derivation and interpretation*, 262–294. Amsterdam: John Benjamins Publishing Company.
- Plank, Frans (ed.). 1995. *Double case: Agreement by Suffixaufnahme*. Oxford: Oxford University Press.
- Pollard, Carl & Ivan Sag. 1994. *Head-Driven Phrase Structure Grammar*. Stanford and Chicago: CSLI Publications and University of Chicago Press.
- Poole, Ethan. 2014. A configurational account of Finnish case. Handout of a talk given at the 38th Penn Linguistics Conference, March 2014.
- Postal, P.M. 1966/1969. On so-called ‘pronouns’ in English. In D. Reibel & S. Schane (eds.), *Modern studies in English*, Englewood Cliffs, NJ: Prentice-Hall.
- Preminger, Omer. 2011. *Agreement as a Fallible Operation*: MIT dissertation.
- Prince, Alan. 1980. A metrical theory for Estonian quantity. *Linguistic Inquiry* 511–562.
- Progovac, Ljiljana. 1998. Determiner phrase in a language without determiners (with apologies to Jim Huang 1982). *Journal of linguistics* 34(01). 165–179.
- Radkevich, Nina & Maria Polinsky. 2013. Agreement between xps: the invisible v(s). Handout of a talk presented at the Little v workshop, Leiden University, October 26, 2013.
- Reinhart, Tanya. 1981. Definite NP anaphora and c-command domains. *Linguistic Inquiry* 12(4). 605–635.
- Rezac, Milan. 2008. Phi-agree and theta-related case. In Daniel Harbour, David Adger & Susan Béjar (eds.), *Phi theory: Phi-features across interfaces and modules*, 83–129. Oxford: Oxford University Press.
- Richards, Norvin. 2012. Lardil “Case Stacking” and the Timing of Case Assignment. *Syntax* 1–35.
- van Riemsdijk, Henk. 1998. Categorical feature magnetism: The endocentricity and distribution of projections. *Journal of Comparative Germanic Linguistics* 2. 1–48.

- Ritter, Elizabeth. 1991. Two functional categories in Modern Hebrew noun phrases. *Syntax and Semantics* 25. 37–60.
- Ritter, Elizabeth. 1992. Cross-linguistic evidence for number phrase. *Canadian Journal of Linguistics* 37(2). 197–218.
- Ritter, Elizabeth. 1993. Where's gender? *Linguistic Inquiry* 24(4). 795–803.
- Schütze, Carson. 2001. On the nature of default case. *Syntax* 4(3). 205–238.
- Selkirk, Elizabeth. 1982. *The syntax of Words*. Cambridge, MA: MIT Press.
- Seppänen, Aimo. 1983. Finnish Ôkaksi poikaaÕ. *Studia Linguistica* 37(2). 161–174.
- Sigurðsson, Halldór Ármann. 1993. The structure of the Icelandic NP. *Studia Linguistica* 47(2). 177–197.
- Sigurðsson, Halldór Ármann. 2004. Agree in syntax, agreement in signs. *Working Papers in Scandinavian Syntax* 74. 1–42.
- Sio, Joanna U.-S. 2006. *Modification and reference in the Chinese nominal*: Leiden University dissertation.
- Stavrou, Melita. 2003. Semi-lexical nouns, classifiers and the interpretation(s) of the Pseudopartitive Construction. In M. Coene & Yves D'Huist (eds.), *From NP to DP. Volume I: The syntax and semantics of noun phrases*, John Benjamins.
- Sulkala, Helena & Merja Karjalainen. 1992. *Finnish*. London and New York, NY: Routledge.
- Svenonius, Peter. 1993. Selection, adjunction, and concord in the DP. *Studia Linguistica* 47(2). 198–220.
- Svenonius, Peter. 1994. The structural location of the attributive adjective. In Erin Duncan & Donka and Philip Spaelti Farkas (eds.), *The proceedings of the twelfth west coast conference on formal linguistics*, 439–454. Stanford University: CSLI.
- Svenonius, Peter. 2004. On the edge. In D Adger, C. de Cat & G. Tsoulas (eds.), *Peripheries: Syntactic edges and their effects*, 259–287. Kluwer Academic Publishers.
- Svenonius, Peter. 2012. *Spanning*. ms., CASTL, University of Tromsø.
- Szabolcsi, Anna. 1983. The possessor that ran away from home. *The Linguistic Review* 3(1). 89–102.
- Szabolcsi, Anna. 1994. The noun phrase. In *The Syntactic Structure of Hungarian*, vol. 27 Syntax and Semantics, 179–274. San Diego: Academic Press.
- Tamm, Anne. 2007. Perfectivity, telicity, and Estonian verbs. *Nordic Journal of Linguistics* 30. 229–255.

- Tamm, Anne. 2011. Scalarity and dimensionality across categories: Estonian pseudopartitive constructions. *Linguistica Uralica* XLVII. 22–40.
- Thráinsson, Höskuldur. 2007. *The syntax of Icelandic*. New York, NY: Cambridge University Press.
- Toivonen, Ida. 2000. The morphosyntax of Finnish possessives. *Natural Language & Linguistic Theory* 18(3). 579–609.
- Toosarvandani, Maziar & Coppe Van Urk. 2012. Directionality and intervention in nominal concord: Evidence from Zazaki ezafe. Handout version of a poster at NELS 43, CUNY.
- Toosarvandani, Maziar & Coppe Van Urk. 2014. Agreement in Zazaki and the nature of nominal concord. ms, UC-Santa Cruz and MIT.
- Tucker, Matthew A. Under Revision. On the Derivation of the Anaphor Agreement Effect. ms., UC-Santa Cruz and New York University.
- Vainikka, Anne. 1993. The three structural cases in Finnish. In *Case and other functional categories in Finnish syntax*, 129–159. Mouton de Gruyter.
- Vainikka, Anne & Joan Maling. 1996. Is partitive case inherent or structural. In Jacob Hoeksma (ed.), *Partitives: Studies on syntax and semantics of partitive and related constructions* Groningen-Amsterdam Studies in Semantics, 179–208. Berlin/New York: Mouton de Gruyter.
- Vihman, Virve-Anneli. 2001. Nothing personal: some detransitivizing devices in Estonian. In *Proceedings of the 2001 taal postgraduate conference, university of edinburgh*, .
- Vihman, Virve-Anneli. 2004. *Valency reduction in Estonian*: University of Edinburgh dissertation.
- Watanabe, Akira. 2006. Functional projections of nominals in Japanese: Syntax of classifiers. *Natural Language and Linguistic Theory* 24. 241–306.
- Wechsler, Stephen & Larisa Zlatić. 2003. *The Many Faces of Agreement*. CSLI Publications.
- Willim, Ewa. 2000. On the grammar of Polish nominals. In Juan Uriagereka (ed.), *Step by step: Essays in Minimalist syntax in honor of Howard Lasnik*, 319–346. Cambridge, MA: MIT Press.
- Yip, Moira, Joan Maling & Ray Jackendoff. 1987. Case in tiers. *Language* 63. 217–250.
- Zabbal, Youri. 2005. The syntax of numeral expressions. ms., University of Massachusetts, Amherst.
- Zlatić, Larisa. 1997. *The structure of the Serbian noun phrase*: University of Texas at Austin dissertation.