

Lawrence Berkeley National Laboratory

Recent Work

Title

HOT WIRE LIQUID-LEVEL INDICATOR

Permalink

<https://escholarship.org/uc/item/84r5k1ng>

Author

Maimoni, Arturo.

Publication Date

1956-01-13

UNIVERSITY OF
CALIFORNIA

*Radiation
Laboratory*

HOT WIRE LIQUID-LEVEL INDICATOR

BERKELEY, CALIFORNIA

DISCLAIMER

This document was prepared as an account of work sponsored by the United States Government. While this document is believed to contain correct information, neither the United States Government nor any agency thereof, nor the Regents of the University of California, nor any of their employees, makes any warranty, express or implied, or assumes any legal responsibility for the accuracy, completeness, or usefulness of any information, apparatus, product, or process disclosed, or represents that its use would not infringe privately owned rights. Reference herein to any specific commercial product, process, or service by its trade name, trademark, manufacturer, or otherwise, does not necessarily constitute or imply its endorsement, recommendation, or favoring by the United States Government or any agency thereof, or the Regents of the University of California. The views and opinions of authors expressed herein do not necessarily state or reflect those of the United States Government or any agency thereof or the Regents of the University of California.

UCRL-3288
Instrumentation Distribution

UNIVERSITY OF CALIFORNIA

Radiation Laboratory
Berkeley, California

Contract No. W-7405-eng-48

HOT WIRE LIQUID-LEVEL INDICATOR

Arturo Maimoni

January 13, 1956

Printed for the U. S. Atomic Energy Commission

HOT WIRE LIQUID-LEVEL INDICATOR

Arturo Maimoni*

Radiation Laboratory
University of California
Berkeley, California

January 13, 1956

ABSTRACT

The theory of the method of measurement of liquid level by measurement of the resistance of a heated wire is developed, and it is applied to the design of a liquid-nitrogen-level indicator having a power dissipation of 3.4 milliwatts per inch of length and a deviation from linearity in the calibration of less than 0.1 inch over its working length of 2.0 inches.

* Present address: University of California Radiation Laboratory, Livermore, California.

HOT WIRE LIQUID-LEVEL INDICATOR

Arturo Maimoni

Radiation Laboratory
University of California
Berkeley, California

January 13, 1956

INTRODUCTION

A number of ways have been developed for controlling the level of low-boiling liquids as applied to automatic filling of cold traps. Of the proposed devices, perhaps the simplest is a commercial bimetallic thermoregulator¹ used to control a solenoid valve. Most of the other devices measure the change in resistance of a wire or a carbon resistor when immersed in the liquid.

Equipment for measurement of level, rather than an on-off indication, may use the change in resistance of a wire,² the change in capacity of a condenser having the two-phase fluid as dielectric,³ or the scattering of x-rays.⁴ Of the above methods, the measurement of change in resistance is perhaps the simplest.

The sensing element is usually a fine wire heated by a small electric current so that it rides at a temperature slightly above ambient temperature. The magnitude of this temperature difference between the wire and the medium is a function of the thermal properties of the medium surrounding it; and for a liquid-vapor interphase, it is a definite function of the liquid level.

The variations in average temperature of the wire with variations in liquid level are reflected in changes in the resistance of the wire, which can be measured with a sensitive bridge circuit, or can give a direct indication of level if an unbalanced bridge is used.

THEORY

Consider a section of heated wire dissipating a certain amount of heat, q , surrounded uniformly by a fluid of heat-transfer coefficient h . From a heat balance on a section of the wire, we can write

¹ M. Lounsbury, Rev. Sci. Instr. 22, 533 (1951).

² A. E. Wexler and W. S. Cox, *Ibid.*, 941 (1951).

³ W. E. Williams, Jr. and E. Maxwell, *Ibid.* 25, 111 (1954).

⁴ J. E. Jacobs and R. R. Wilson, *Electronics* 24, 172, 176, 180, 184, 188, 192 (October 1951).

$$\frac{\partial U}{\partial \theta} + \frac{q}{\rho C_p A_c} - \frac{A_s h}{\rho C_p A_c} U + \frac{K}{\rho C_p} \left(\frac{\partial^2 U}{\partial x^2} \right) = 0, \quad (1)$$

where

- U = temperature difference between wire and medium,
- θ = time,
- q = heat dissipation per unit length,
- ρ = density,
- C_p = specific heat,
- A_c = cross-sectional area,
- A_s = surface area per unit length,
- h = heat-transfer coefficient of the fluid,
- K = thermal conductivity of the wire,
- x = distance along wire.

For steady-state conditions we have $(\partial U / \partial \theta) = 0$, and the equation simplifies to

$$\frac{\partial^2 U}{\partial x^2} - a^2 U = -b, \quad (2)$$

where $a^2 = A_s h / K A_c$ and $b = q / K A_c$.

For a semi-infinite wire, with one end clamped so that at $x = 0$ $U = 0$, Eq. (2) can be integrated to

$$U(x) = U_\infty (1 - e^{-ax}), \quad (3)$$

$$U_\infty = b/a^2 = q/A_s h, \quad (4)$$

where U_∞ is the steady-state temperature difference between the wire and the medium at $x = \infty$.

For a finite wire of length L, with both ends clamped, $U = 0$ at $x = 0$ and at $x = L$,

$$U(x) = U_\infty \left(1 - \frac{1}{1+a} e^{ax} - \frac{a}{1+a} e^{-ax} \right), \quad (5)$$

where

$$a = e^{aL}, \quad (6)$$

and the average temperature of such a wire is given by

$$U_{av} = U_{\infty} \left(1 + \frac{2}{aL} \frac{1-a}{1+a} \right). \quad (7)$$

The general case, when a wire of length L is immersed in liquid to a depth l , requires separate equations for the vapor and liquid phases, which have to meet the following boundary conditions:

$$\begin{array}{ll} x = 0 & U = 0 \\ x = L & U' = 0 \\ x = l & U = U' \\ x = l & dU/dx = dU'/dx, \end{array}$$

and the resulting coefficients for equations of the form

$$U = U_{\infty} + C_1 e^{ax} + C_2 e^{-ax} \quad (8)$$

are functions of L , l , a , a' , U_{∞} , U'_{∞} , where the primed quantities apply to the vapor phase.

Design considerations, however, require only the solutions for the finite and semi-infinite wires surrounded by a uniform medium.

DESIGN CONSIDERATIONS

The liquid-level indicator was required to indicate liquid level to better than 0.1 inch, in a total span of 2 inches, with a very small power dissipation.

Table I is a comparison of calculated values for several possible sensing elements, operating on the system acetone-air at room temperature.

The sensing elements were compared under conditions which gave the same values of temperature difference between the element and the fluid, conditions which also yield approximately the same values for the heat-transfer coefficients.

Under these conditions, Eq. (4) indicates that the power required to obtain a given temperature difference at a large distance from one of the terminals is directly proportional to the surface area; thus we see it is advantageous to operate with a very fine wire.

The sensitivity of the liquid-level indicator, however, depends not only on the power dissipated, but also on the ratio of heat transferred to the fluid to heat transferred longitudinally along the wire--a factor which appears exponentially in Eq. (3) through (8). This factor "a" was calculated for the different sensing elements and appears in Table I together with its reciprocal, which for the semi-infinite wire is the distance along the wire necessary for a 63 percent approach to U_{∞} . On the same table appears the average temperature that the 2-inch sensing element would assume in contact with air under the same conditions.

Table I

Characteristics of different liquid-level indicators for the system acetone-air at room temperature

Sensing Element	$(U)_L$ (°C)	$(U)_G^*$ (°C)	q (watts/in.)	a ft ⁻¹	"Sharpness" (1/a in.)	$(U_{av})_G$
No. 40 copper wire	1	39	1.1×10^{-3}	8.3	1.45	5.2
2-mil platinum wire	1	39	7.1×10^{-4}	24.4	0.51	19.8
1-mil quartz, silver-plated	1	39	2.6×10^{-4}	46.8	0.25	29.2
1-mil platinum wire	1	39	2.6×10^{-4}	34.5	0.35	25.5
0.5-mil platinum wire	1	39	1.8×10^{-4}	48.9	0.25	29.2
platinum ribbon 0.001 by 0.002 in.	1	39	2.5×10^{-4}	61-81.0	0.19-0.15	31.6

* Calculated using $h = 1 \text{ Btu/hr} \times \text{sq. ft.} \times ^\circ\text{F}$, which is approximately the gas-film heat-transfer coefficient.

Thus it appears that either a 0.0005-inch platinum wire or a platinum ribbon would be the most advantageous sensing elements. The 0.5-mil wire requires a smaller power input than the ribbon to maintain the same temperature difference, but the ribbon gives a more linear response near the ends of the filament, an effect which is more noticeable in short sensing elements. The platinum wire should not be silver coated (Wollaston wire), however, because the thermal conductivity of silver is about six times that of platinum, thus offsetting some of the advantage of the small diameter.

A platinum ribbon approximately 1 mil x 0.2 mil was used as the sensing element and was made by rolling 3-mil Wollaston platinum wire into a ribbon 1 mil thick. This ribbon was wound on a glass tube and the silver dissolved with nitric acid. The resulting ribbon has a resistance of about 22 Ω /inch at room temperature and is very uniform throughout its length.

The liquid-level indicator was mounted as indicated in Fig. 1 and its resistance was measured by means of the bridge circuit shown in Fig. 2. The 20- μ a full-scale meter was calibrated directly in inches.

Although the bridge was operated with rectified ac, it is shown battery-operated, because the reading is very sensitive to variations in operating current and battery operation probably would be more satisfactory.

CALIBRATION AND RESULTS

The instrument is calibrated by adjusting the Helipot R-4 so that ME-1 reads zero when the sensing element is completely immersed in liquid, then, by adjusting the current and the sensitivity, the 20- μ a meter can be made to read full scale when totally outside the liquid. It may be necessary to readjust the settings until the meter reads correctly at the two ends of the scale.

The calibrating procedure given above is satisfactory when the instrument is to operate always in the same liquid and the same gas, under identical conditions of temperature and pressure; however, it was desired to obtain a method of calibration whereby the instrument could be calibrated rapidly, without resort to visual indications, and under widely different conditions of pressure, temperature, and composition of the phases.

The procedure adopted, which gave satisfactory results for the systems acetone-air at room temperature and liquid nitrogen-nitrogen vapor at 1 atmosphere pressure, is as follows:

- (a) Adjust R-5 for maximum sensitivity.
- (b) With the sensing element totally immersed in liquid, and the lowest current (about 1.5 ma), adjust the Helipot R-4 to balance the bridge, Record the Helipot reading, R_1 .
- (c) Gradually increase the current and plot bridge unbalance versus sensing-element current, Curve A in Figs. 3 and 4.
- (d) Plot bridge unbalance versus current with the sensing element completely in contact with the gas, Curve B in Figs. 3 and 4.

(e) Note the current I_1 at which the bridge gives full scale in the gas, and from the plot read the corresponding reading in the liquid, L_{liq} . Extrapolate curve B for the gas until $L_{gas} = L_{liq} + 2$ (the 2 being the full-scale reading desired).

(f) Reduce the current until the reading in the gas is the same as L_{liq} mentioned under (e).

(g) Adjust the Helipot R-4 until bridge is balanced (zero) and record the Helipot reading R_2 .

(h) Set the Helipot at the intermediate value $(R_1 + R_2)/2$ and adjust the current to obtain full-scale deflection in the gas.

(i) Record the current I_2 . This is the correct operating current for the sensing element.

The instrument is then adjusted to read correctly at the two ends of the scale for the given liquid and gas phases.

The above procedure is especially advantageous when the heat-transfer properties of the liquid phase change slowly with pressure, temperature, or composition, since it is then possible to prepare a family of curves of bridge unbalance versus current for the liquids, and variations in the properties of the gas phase can be taken care of by individual calibrations under the different conditions. Step (h) of the calibration procedure gives rise to some error, especially at the higher pressures, when the deflection-versus-current curves are more nearly parallel and a higher operating current is required.

The linearity of the sensing element is satisfactory, as can be seen in Fig. 5, which compares the platinum ribbon with 1-mil platinum wire, showing that, as predicted, the ribbon gives a more linear response. The data were obtained in the system acetone-air at room temperature, with the power dissipated by the wire about four times as great as the power dissipated by the ribbon.

Also shown in Fig. 5 is the response of the 1-mil platinum wire under nonisothermal conditions such as would be obtained in measuring the level of liquid nitrogen in an open container, where appreciable temperature gradients exist in the gas phase. The deviations from linearity are then quite appreciable.

The scatter in the experimental data shown is due to variations in the operating current, and a part of the deviations from linearity could be ascribed to the difficulty in obtaining a perfectly taut filament out of such fine wire.

The power dissipation of the liquid-level indicator under operating conditions at liquid nitrogen temperatures was about 3.4 milliwatts per inch or 6.8 milliwatts for the total length.

The calibrating procedure given above was found to be fairly reliable at low pressures or for operation with pure nitrogen vapor. Thus reliable results were obtained with pure nitrogen at 100 psig; however, if hydrogen is added to the vapor phase it increases the heat transfer coefficient of the vapor to the point where the above calibrating procedure was not reliable at operating pressures of about 300 psig, with hydrogen concentrations in the vapor of the order of 75 percent.

ACKNOWLEDGEMENTS

The author is indebted to Dr. D. N. Hanson for his encouragement and support of the work and to Mr. D. O'Connell of the Accelerator Technicians for making the silver-coated quartz filament and for fabricating the platinum ribbon.

This work was performed under the auspices of the U. S. Atomic Energy Commission.

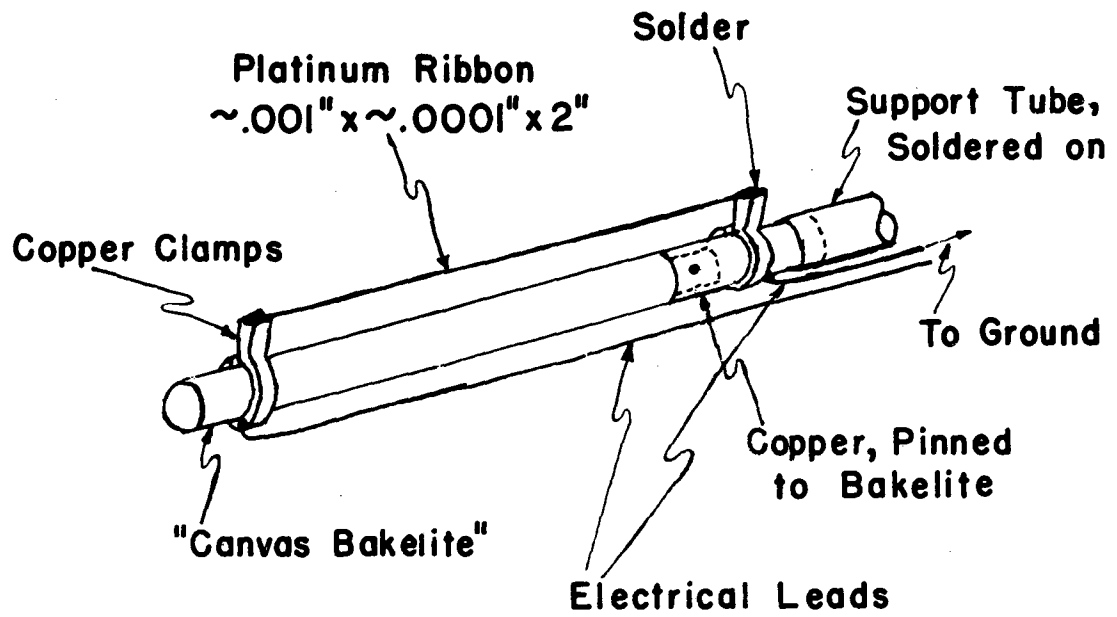

MU-9616

Fig. 1. Liquid-level indicator.

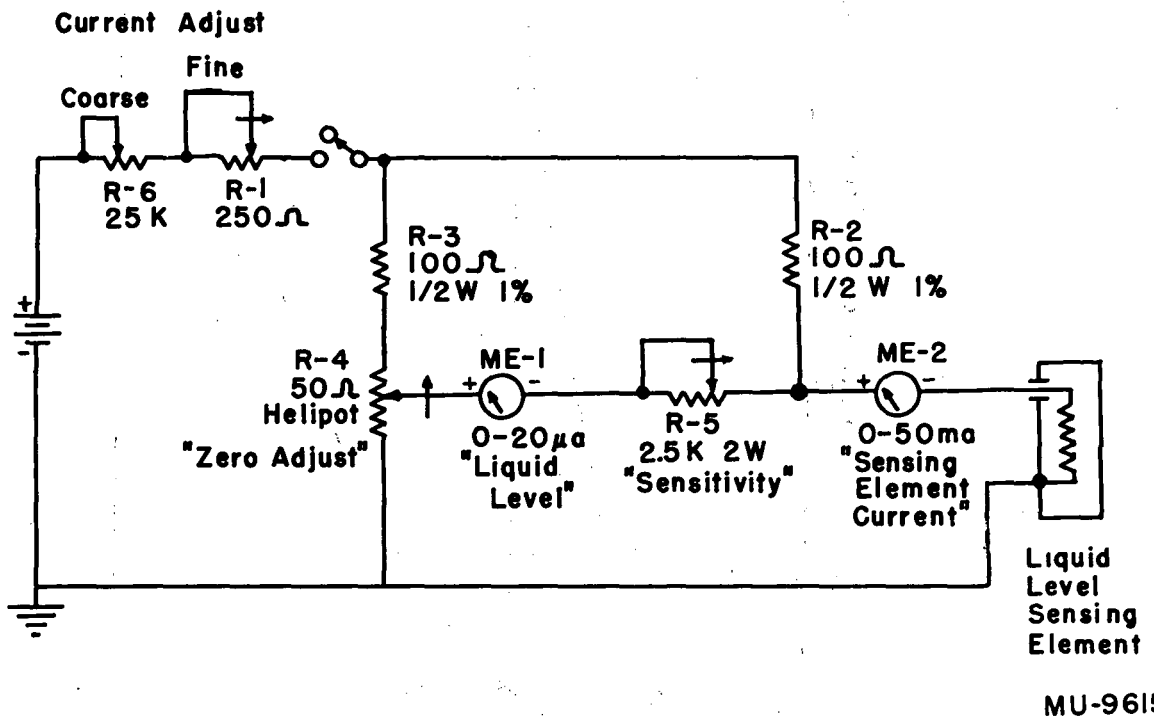

Fig. 2. Circuit diagram for liquid-level indicator.

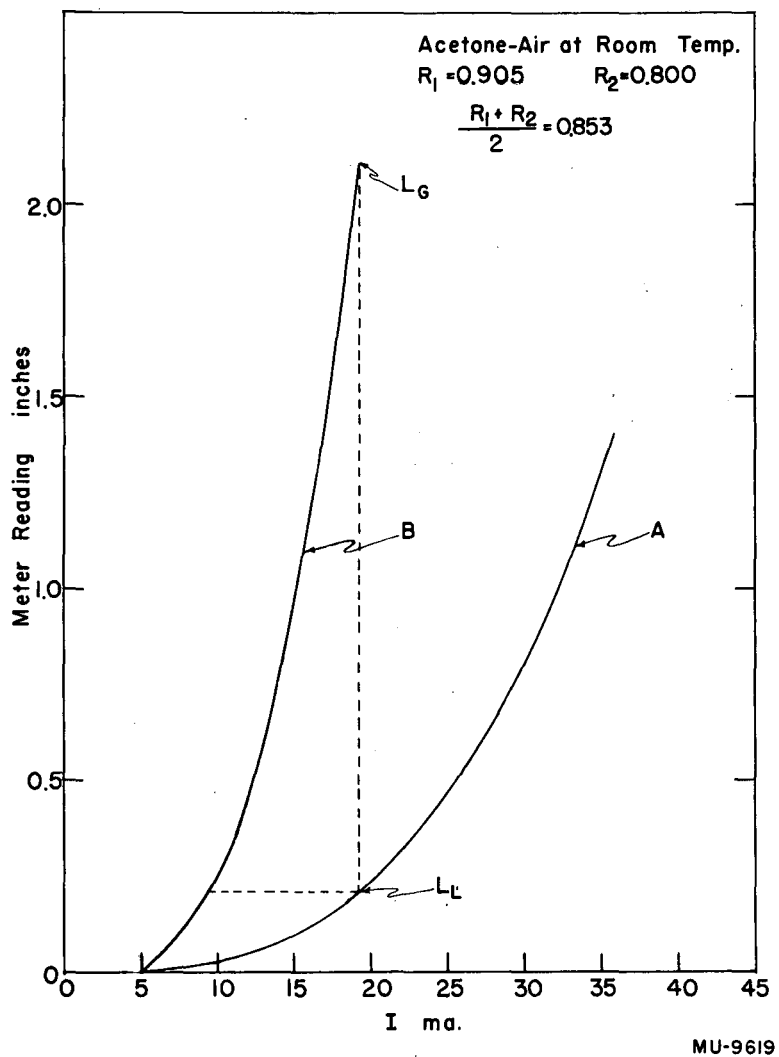

Fig. 3. Curve for calibration of liquid-level indicator, acetone-air at room temperature.

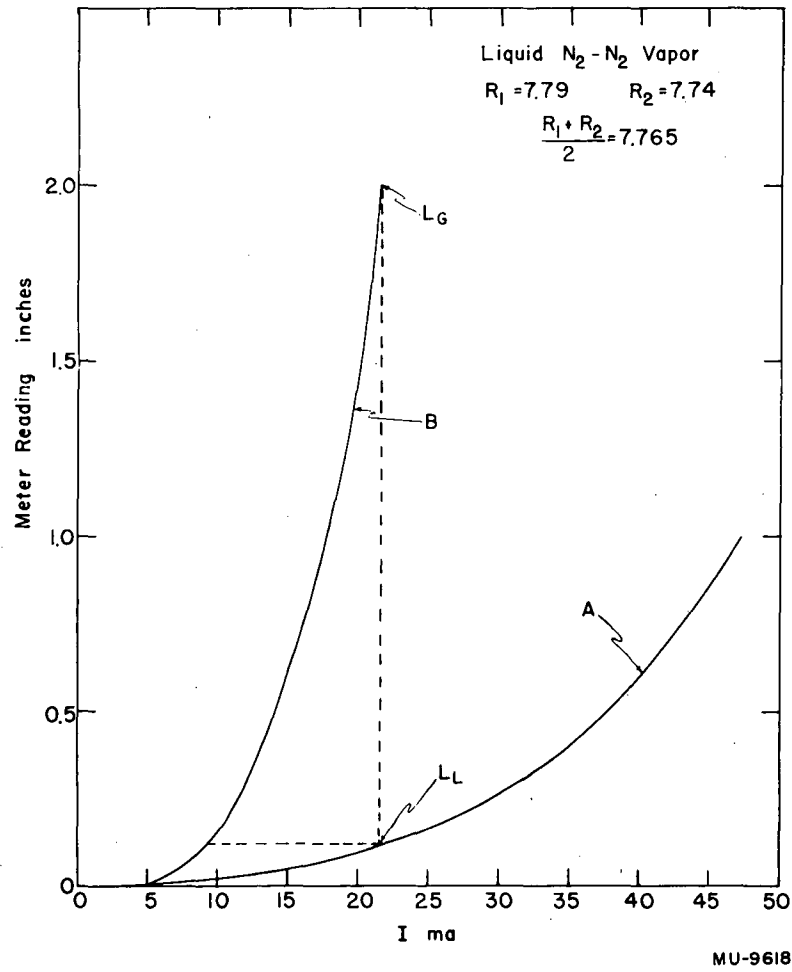

Fig. 4. Curve for calibration of liquid-level indicator, liquid nitrogen-nitrogen vapor at 1 atmosphere.

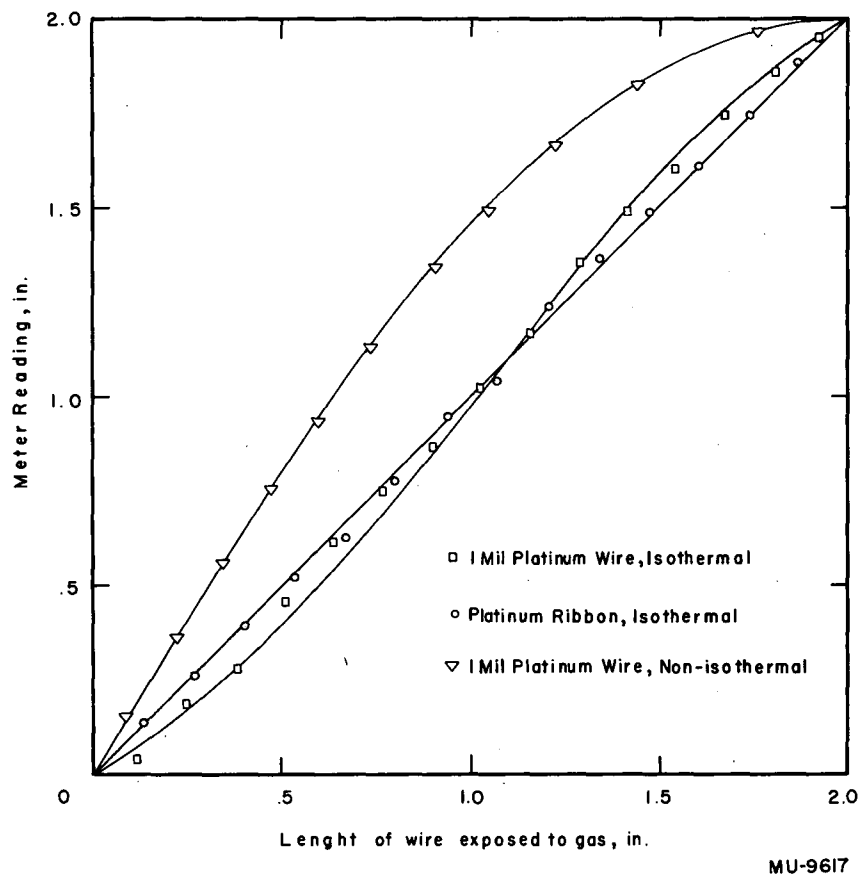

Fig. 5. Linearity of liquid-level indicator.