

Lawrence Berkeley National Laboratory

LBL Publications

Title

Liquid-Hydrogen Bubble Chambers

Permalink

<https://escholarship.org/uc/item/8708m45g>

Authors

Parmentier, Douglas

Schwemin, Arnold J

Publication Date

1955-03-01

UCRL 2923

UNIVERSITY OF
CALIFORNIA

*Radiation
Laboratory*

TWO-WEEK LOAN COPY

*This is a Library Circulating Copy
which may be borrowed for two weeks.
For a personal retention copy, call
Tech. Info. Division, Ext. 5545*

BERKELEY, CALIFORNIA

DISCLAIMER

This document was prepared as an account of work sponsored by the United States Government. While this document is believed to contain correct information, neither the United States Government nor any agency thereof, nor the Regents of the University of California, nor any of their employees, makes any warranty, express or implied, or assumes any legal responsibility for the accuracy, completeness, or usefulness of any information, apparatus, product, or process disclosed, or represents that its use would not infringe privately owned rights. Reference herein to any specific commercial product, process, or service by its trade name, trademark, manufacturer, or otherwise, does not necessarily constitute or imply its endorsement, recommendation, or favoring by the United States Government or any agency thereof, or the Regents of the University of California. The views and opinions of authors expressed herein do not necessarily state or reflect those of the United States Government or any agency thereof or the Regents of the University of California.

UCRL-2923

UNCLASSIFIED

UNIVERSITY OF CALIFORNIA

Radiation Laboratory

Berkeley, California

Contract No. W-7405-eng-48

LIQUID-HYDROGEN BUBBLE CHAMBERS

Douglas Parmentier, Jr., and Arnold J. Schwemin

March 15, 1955

Printed for the U.S. Atomic Energy Commission

LIQUID-HYDROGEN BUBBLE CHAMBERS¹

Douglas Parmentier, Jr., and Arnold J. Schwemin

Radiation Laboratory, Department of Physics,
University of California, Berkeley, California

March 15, 1955

In 1952 Donald Glaser² showed that superheated liquid ether would erupt immediately in the presence of a cobalt-60 source and that its normal delayed eruption was triggered by cosmic rays or "local radiation." In 1953³ he was able to photograph the passage of such particles through a chamber 3 cm long and 1 cm in inside diameter. Later in the same year Roger Hildebrand⁴ showed that superheated liquid hydrogen was also sensitive to radiation. Early in 1953 Luis Alvarez initiated a development program of liquid hydrogen chambers at Berkeley. John Wood⁵ constructed a glass chamber 1 inch in diameter and $\frac{1}{2}$ inch thick in which he photographed tracks. This paper is concerned with the work carried on from that point by the authors.⁶

The work began with a chamber 2.5 inches in inside diameter and 1 inch thick (Fig. 1). An all-glass chamber of this size required such great wall thickness to contain the necessary working pressures that heat transfer through the walls was insurmountably difficult. The chamber itself finally consisted of a brass cylinder 1 inch long, 2.5 inches in inside diameter, and 3/16 inch in wall thickness, with end ports of 5/16-inch Pyrex glass. Surrounding the chamber was a pressure vessel "bath" for containing liquid

-
- 1 Paper presented at a "Conference on Recent Development in Cloud Chamber and Associated Techniques", Physics Dept., University College London, March 25, 1955
 - 2 D. Glaser Phys. Rev. 87, 665 (1952)
 - 3 D. Glaser Phys. Rev. 91, 762 (1953)
 - 4 R. Hildebrand and D. Mogle, Phys Rev. 92, 517 (1953)
 - 5 John Wood, Phys. Rev. 94, 731 (1954)
 - 6 D. Parmentier, A. J. Schwemin, L. W. Alvarez, F. S. Crawford and M. L. Stevenson, Abstract U 12. Bulletin of the American Physical Society 29, 8 (1954)
 - 7 Forster and Zuber, Journal of Applied Physics 25, 474 (1954)
Plesset and Zwick, Journal of Applied Physics 25, 493 (1954)

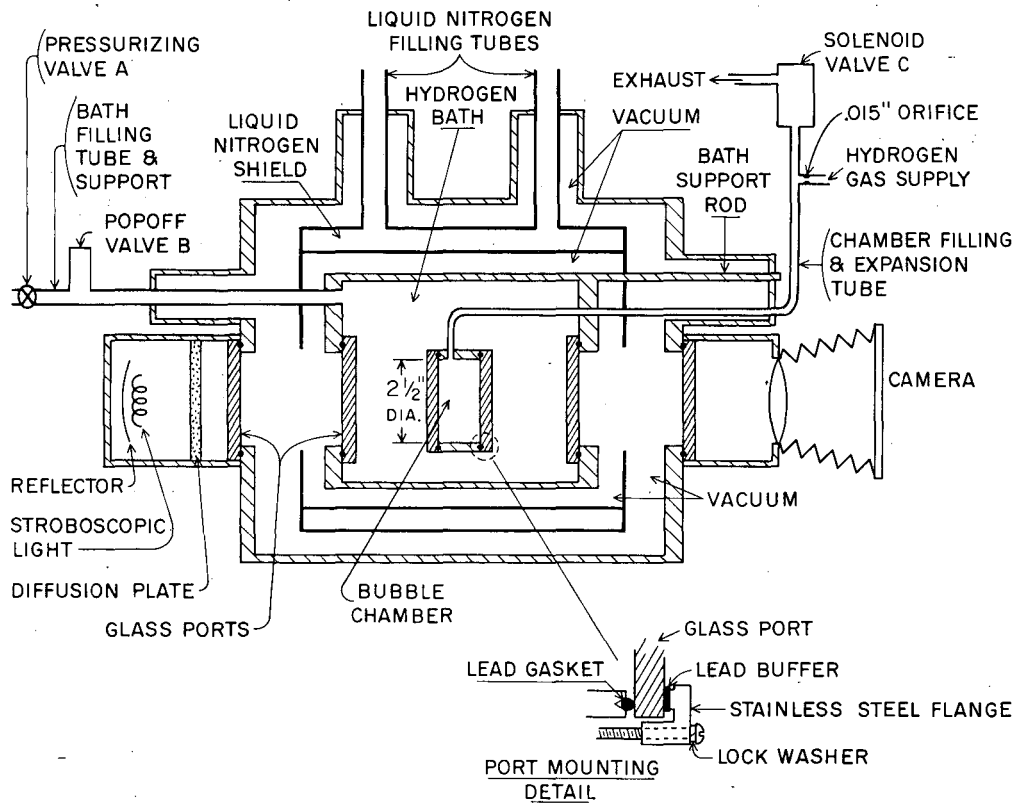

MU-9069

Fig. 1 2-1/2-inch Chamber

hydrogen, with viewing ports to observe the chamber. Surrounding this assembly was an appropriate liquid-nitrogen heat shield and a vacuum tank, also with viewing ports.

Probably the greatest problem to be overcome was the method of joining the glass ports to the brass cylinder. There was no literature available concerning glass-to-metal seals of this size for use at 20° Kelvin. Nor was there gasket information. Up to now, cryogenics workers had no desire for visual observation over large areas, and their seals were mostly polished surfaces of similar metals where there was no difference in the coefficient of expansion. Various Kovar metal-to-glass seals were designed and tested. In each case the glass cracked, either in being cooled to 20° K, or in the warming-up process. Indium solder used as a metal-to-glass seal merely sheared off at the joint. Gaskets of Teflon and gold were tried but proved most undependable.

Finally, lead wire of about 3/64 inch in diameter was drawn through dies. This proves satisfactory for port diameters up to 5 inches and is now our standard method. This may not be the limit, for larger diameters have not been tried. The gasket groove is made in the form of a shallow V in the end of the brass cylinder. This is used both to position the gasket and to facilitate removal and replacement. The gasket material is cut to length with a razor blade to assure square ends. The ends are butted together and the capillary action of molten solder applied from below serves to join the two ends. The lead must be clean before drawing and the surface free from lead carbonate. After drawing, the lead should be used within a day or so, before lead carbonate reforms and gives a semiporous crust to the wire. The bolts holding the flange for the ports are spaced as close together as is practical, in order to provide even loading on the gasket, and must be spring-loaded in addition. (See detail on Fig. 1). In practice, common spring-type lock washers are used. A lead ring $\frac{1}{4}$ inch wide and $\frac{1}{32}$ inch thick, cut so it opposes the gasket, and placed between the port and holding flange, provided a buffer and aids in distributing the bolt load.

It is well to emphasize at this point that utmost cleanliness must be maintained on the glass ports. Scratches, fingerprints, and dirt present nucleation centers where boiling occurs when the pressure drops, thus giving the photographs an undesirable bubble background. Cleanliness in the rest of the chamber is unimportant, since the entire cycle is over before

bubbles elsewhere have time to grow large enough to interfere with the tracks. A ring of bubbles where the liquid "sees" the gasket edge is to be expected, and does not interfere with the operation of the chamber. These bubbles will be seen in photographs to be shown later.

Before the chamber is cooled, extreme caution must be exercised to remove all air and water vapor. The chamber must be flushed out with hydrogen gas and pumped down several times to clean the system. If this is not done, air condenses and freezes in the filling line and drops into the chamber at the first operating cycle, producing "sand". This is a potentially explosive condition if the "sand" is oxygen crystals.

Operation of the chamber (Fig. 1) was as follows: The bath was precooled with liquid nitrogen, which was allowed to boil off. Liquid hydrogen was put into the bath through the filling tube shown at the left of the drawing. This brought the chamber and bath into equilibrium at 20°K. The chamber was then pressurized to about 5 atmospheres through an 0.015-inch orifice (right-hand side of Fig. 1.) with pure gaseous hydrogen precooled to liquid nitrogen temperature, which condensed, thus filling the chamber. At this time the bath was sealed off by closing valve "A". Heat gained by radiation raised the temperature to about 27°K, and a pop-off valve "B", set to 65 lb, opened intermittently and maintained this operating temperature and this pressure value.

Fast pressure release, or "pulsing," a requirement in chambers of this type, was done through the 3/16-inch stainless steel filling tube (bypassing the 0.015-inch filling orifice). A modified solenoid valve "C", opening quickly, released the pressure in the chamber to 1 atmosphere in about 10 milliseconds, and a superheated condition was maintained for about 30 milliseconds, during which time a pulsed source introduced particles. The resulting bubble tracks were photographed by flashing a short-time-constant stroboscopic light. This method of releasing the pressure was admittedly inefficient, since the liquid lost to the atmosphere during pulsing had to be replaced by condensing fresh gaseous hydrogen. However, we were able to pulse about every 3 minutes, and the entire system gave us a basis upon which to design larger, more useful chambers.

Testing the operation of the chamber can be done to a certain degree with liquid nitrogen, which is also radiation-sensitive. We have never observed tracks in nitrogen, although it is possible to get single-bubble eruptions with

a PoBe source. Figure 2A shows numerous bubbles in liquid nitrogen. This indicates that the chamber mechanism and superheat requirements have been met and that the chances are good for getting tracks in liquid hydrogen. (Note the ring of bubbles around the outside at the gasket edge as mentioned above) Figure 2B shows only a few eruptions with the same source held the same distance away. This indicates that now the pressure in the chamber is probably not low enough, and there is little possibility of obtaining tracks in hydrogen.

The stroboscopic light source looks into the chamber from 180° to the camera, through a light diffuser, and thus provides a silhouette of the track bubbles to the camera. In operation, the camera shutter is open all the time and the strobe light is flashed with variable delays from a chassis which also pulses the source. By this method, the duration of superheat and the bubble growth rate can be studied. This growth rate seems to follow the law $r \sim 0.2t^{1/2}$, where r is the radius of the bubble in mm and t is the age in milliseconds.⁷

The success of the 2.5-inch chamber led to the design and construction of a chamber 4 inches in diameter and 2 inches thick, as shown schematically in Fig. 3.

It was determined that it was not necessary, after all, to surround the chamber with a bath at 27°K , and that heat conductivity of copper between a flask of liquid hydrogen at 20°K and a chamber at 27°K was more than sufficient to maintain liquid in the chamber. This eliminated the need for heavy pressure walls to contain the bath, and also removed the additional liquid hydrogen through which particles must pass before entering the chamber.

In order to eliminate the loss of liquid during pulsing, a stainless steel bellows was inserted in the chamber. This bellows was to collapse rapidly upon demand, thereby lowering the pressure and creating superheat in a closed system. A series of bellows designs and installations failed to produce results -- except for a cylinder of bubbles around the convolutions. It is thought that violent turbulence at the convolutions as the bellows collapse causes sufficient boiling and expansion of gas to prevent the chamber pressure from reaching a low enough value. Because of limited space it was not possible to insert a larger-diameter bellows that would be collapsed to a lesser degree. A further investigation of bellows is planned for use in the

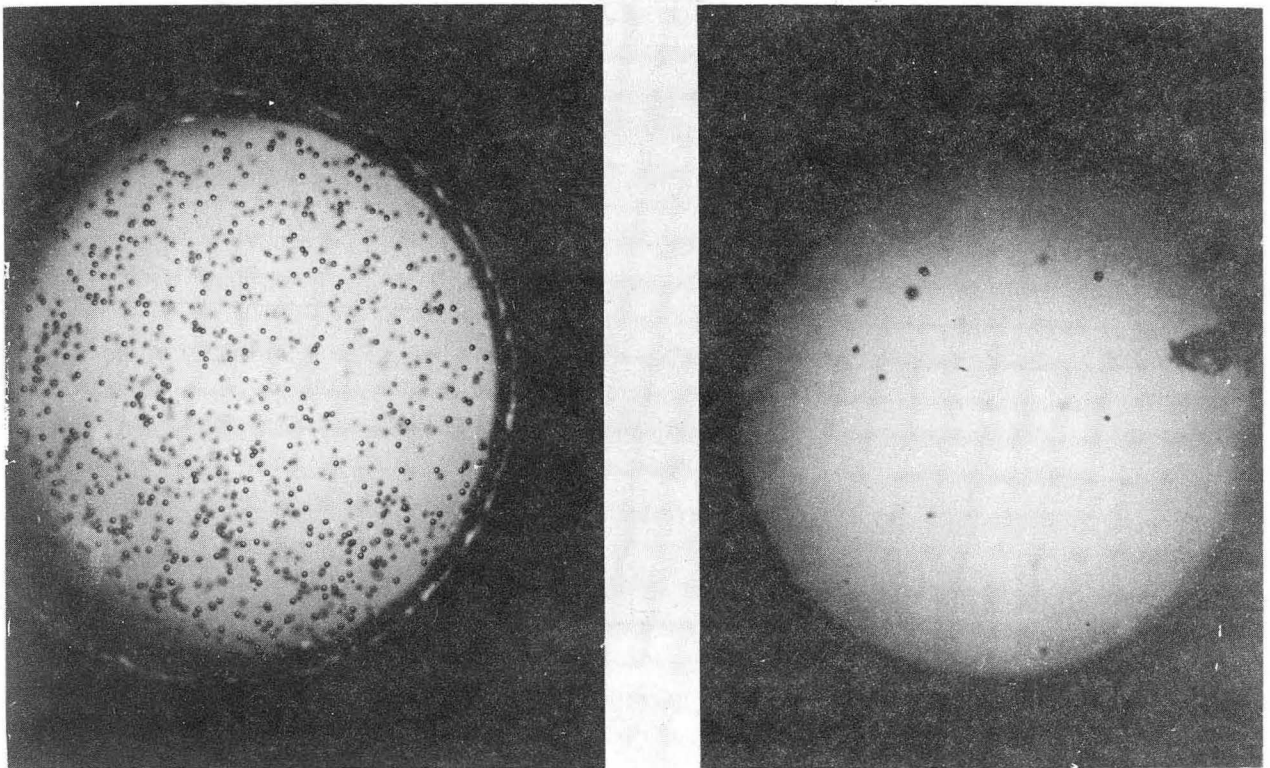

ZN-1187

Fig. 2A and 2B Nitrogen Eruptions

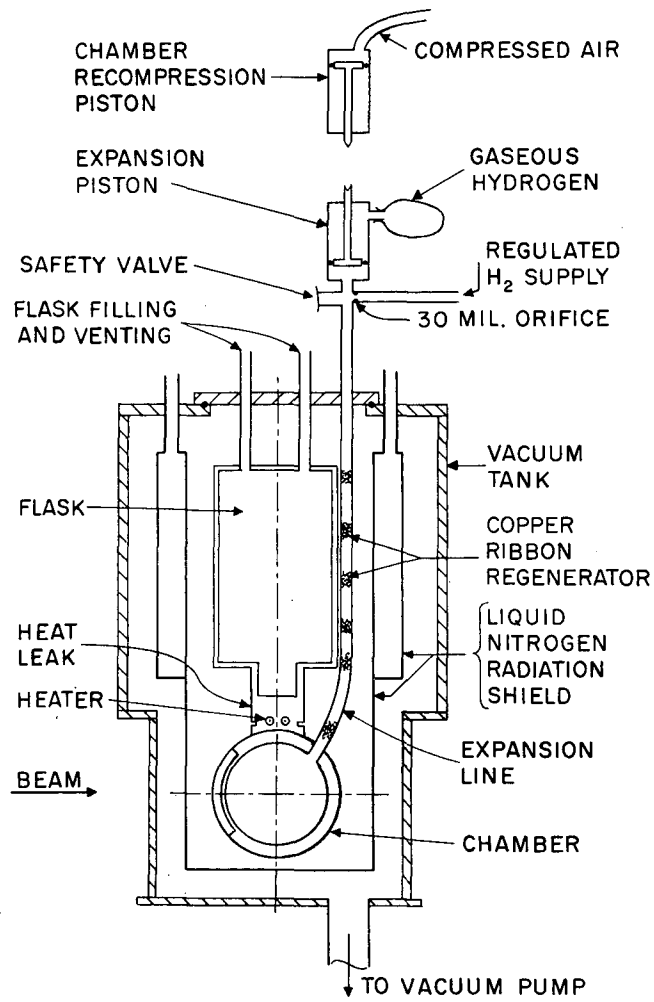

MU-8837-A

Fig. 3 4-inch Chamber

larger chambers to be briefly discussed later.

To satisfy the immediate needs of the physics research program, it was decided to construct the present system (Fig. 3), however inefficient. Two unsuccessful methods of heat transfer are described later. The heat-transfer system now used is a copper slug between flask and chamber in which is imbedded a resistance heater. Current to the heater is varied to maintain the proper temperature in the chamber. This method is inherently inefficient, in that heat is also supplied to the flask, causing unnecessarily fast boil-off of liquid hydrogen.

The larger chamber was first pulsed by the same method as the 2.5-inch chamber to see if it would work satisfactorily with all the new modifications. Success was immediate and an expansion-recompression piston system was installed at the end of the expansion line (top of Fig. 3). The volume of the expansion cylinder on this installation is the same as the volume of the chamber itself. Since this method worked successfully from the beginning no further modifications were made. It is possible that a smaller expansion volume would be just as effective. Until the time for expansion of the chamber, the piston remains locked in the compressed position by a key that can be released by means of a solenoid. About 50 milliseconds before the beam of particles is pulsed through the chamber the solenoid is actuated and the key is released. The piston then expands under the pressure of the hydrogen vapor in the expansion tube, thereby reducing the pressure in both tube and chamber, and in effect superheating the liquid in the chamber. About 5 milliseconds after the particles pass through the chamber, the stroboscopic light is flashed and the picture is taken with a stereo camera oriented with its axis perpendicular to the flight of particles.

At the suggestion of R. L. Garwin, a heat regenerator similar to one described in the Philips Technical Review 9, 103 (1947) is placed inside the expansion tube, which is also used for filling, in the region between the liquid hydrogen and the room-temperature expansion piston. This consists of a series of copper ribbon tufts strung on a thin stainless steel wire. The regenerator permits pulsing the chamber without prohibitive heat input. Permissible cycling rate with the use of the regenerator increases from once in five minutes to a maximum of every four seconds, although the rate is usually governed by the pulse rate of the Bevatron accelerator, which is about five cycles per minute.

The atmosphere above the expansion piston is maintained as pure hydrogen gas. This insures that the chamber will not become contaminated if the piston should leak. Filling the chamber is accomplished by the same series of operations as in the 2.5-inch chamber, except that there is no pressurized bath.

By controlling the operating pressure of the chamber, one can "bias out" the tracks of minimum ionizing particles. Figures 4A and 4B are photographic examples of this technique. The source was pulsed neutrons. Figure 4A shows a multitude of electron tracks originating in the walls of the chamber. Scattered proton tracks are difficult to identify. Operating conditions of the chamber for this result are 70 lb pressure and 27°K. In Figure 4B the electrons have been biased out, leaving only the proton tracks. This photograph was taken with the chamber at 50 lb pressure and 26°K.

Illumination of the bubbles, until recently, has been as in the 2.5-inch chamber, but a suggestion of Harvey White has now provided us with dark-field illumination which gives greater contrast (Fig. 5).

The two methods of heat transfer that proved unsuccessful are shown in Figs. 6A and 6B. The first was a mechanically operated bellows (6A) designed to make contact between flask and chamber when the temperature in the chamber reached too high a level. It involved silvered contact surfaces, polished flat, but they did not give enough area for efficient heat transfer. The second system (6B) consisted of a series of interspaced vanes between the flask and chamber. Helium pressure was applied to the space between vanes when more heat transfer was desired, or a vacuum was pumped when less was required. The failure of this method was attributed to the low heat conductivity of the gas and the small total space available for the installation.

Pressure readings inside the chamber have recently been refined by the use of a capacitor microphone system designed by William H. Linlor (Fig. 7A). One plate of the capacitor is a diaphragm, 0.020 inch thick and 1 inch in diameter, which forms part of the chamber wall. Motion of this diaphragm during pulsing with relation to a fixed plate behind it produces a signal viewed on an oscilloscope. (A detailed schematic drawing of this system is available for those interested.) Temperature readings (Fig. 7B) are provided by two copper-constantan thermocouples, connected back to back, one of which is immersed in the 20°K flask for reference,

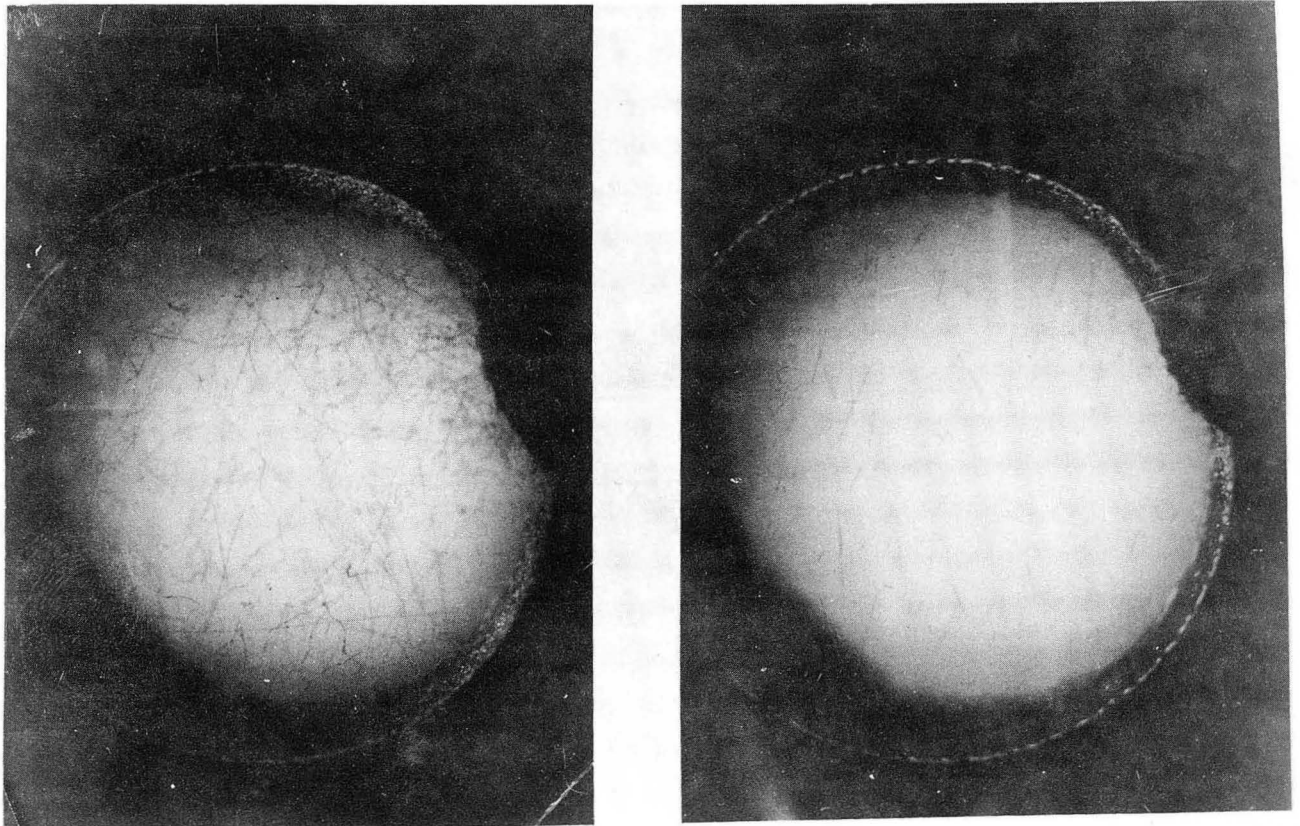

ZN-1188

Fig. 4 Minimum Ionizing Particle "biasing"

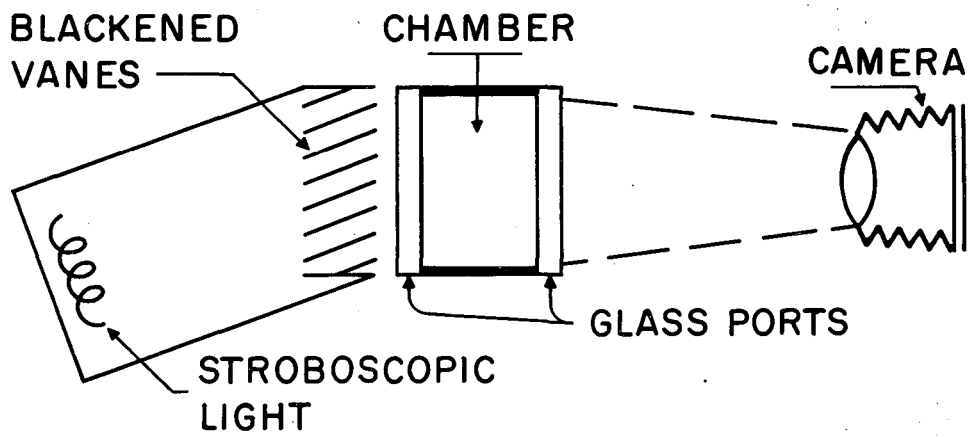

MU-9066

Fig. 5 Dark-Field Illumination

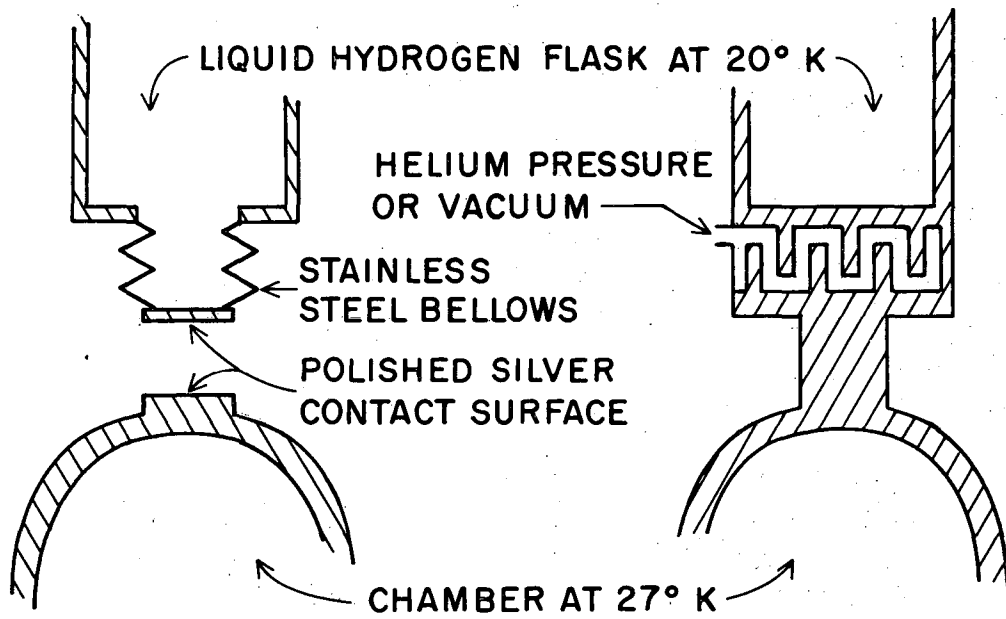

MU-9067

Fig. 6A and 6B Unsuccessful Heat Transfer Methods

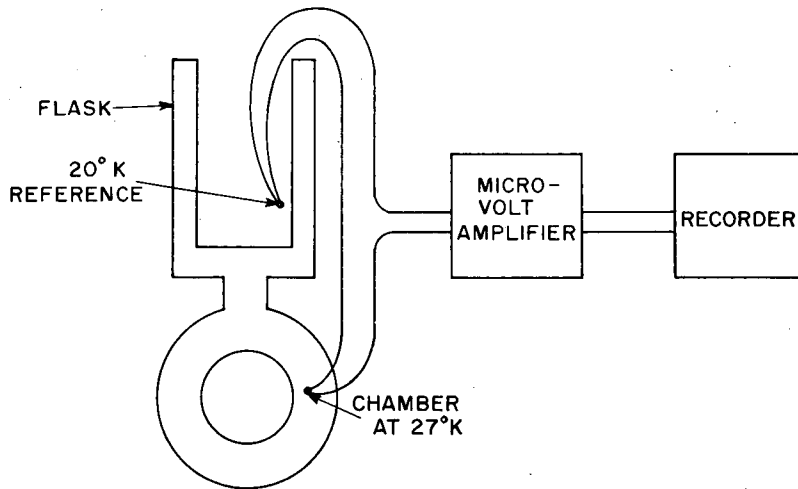
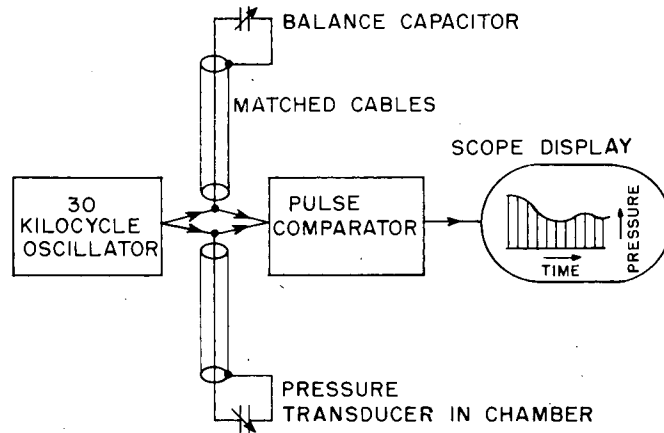

MU-9068

Fig. 7A and 7B Block Diagrams of Pressure and Temperature Monitor Systems

the other mounted on the side of the chamber.

Magnetic field coils, now being designed for use with this chamber, will greatly enhance its usefulness.

Figure 8 shows the chamber set up in the external beam enclosure of the 184-inch cyclotron with a π^+ beam passing through it. An interesting side-light is that the first photograph taken at the cyclotron showed that the π^+ beam was not on, but managed to show the passing of a cosmic particle accompanied by delta rays. Figure 9 is a photograph of a π - μ -electron decay with the chamber in this position.

Figure 10 shows the chamber in location at the Bevatron, in the 3.5-Bev π^- beam. Figure 11 is a picture of a possible π -p elastic scattering. Figure 12 shows Λ event. Figure 13 shows a stereoscopic view of a Λ event. Figure 14 shows a stereoview of an incident π^- meson and the resulting four prong star tentatively identified as pion pair production.

Two other larger chambers are now being designed. The first is to be 10 inches in diameter and 5 inches thick, and designed along the lines of the 4-inch chamber but with certain modifications still in the experimental stage, and is to be used with an existing cloud chamber magnet. The second is to be 20 by 20 by 50 inches, with a magnet designed around it. With a chamber of this size it will be possible to study such reactions as $\pi^- + p \rightarrow \theta^0 + \Lambda^0$ from 2 to 6 Bev. This large chamber will have a refrigeration system rather than a flask, and it is hoped that a system of large-diameter bellows, moving a short distance, will provide a good pulsing method. The gaskets will again become a major problem, owing to size of the ports. In any case, a series of investigations is in progress covering all phases of operation of a chamber of this size.

We should like to thank Professor Luis W. Alvarez, Drs. Frank S. Crawford, Jr., and M. Lynn Stevenson for help and suggestions, and Mr. Vern G. Ogren for designing the electronic control circuits. Lts. Harry Dittler and Frank Gerecke, of the U. S. Navy, have contributed much cheerful assistance. This work has been done under the auspices of the U. S. Atomic Energy Commission.

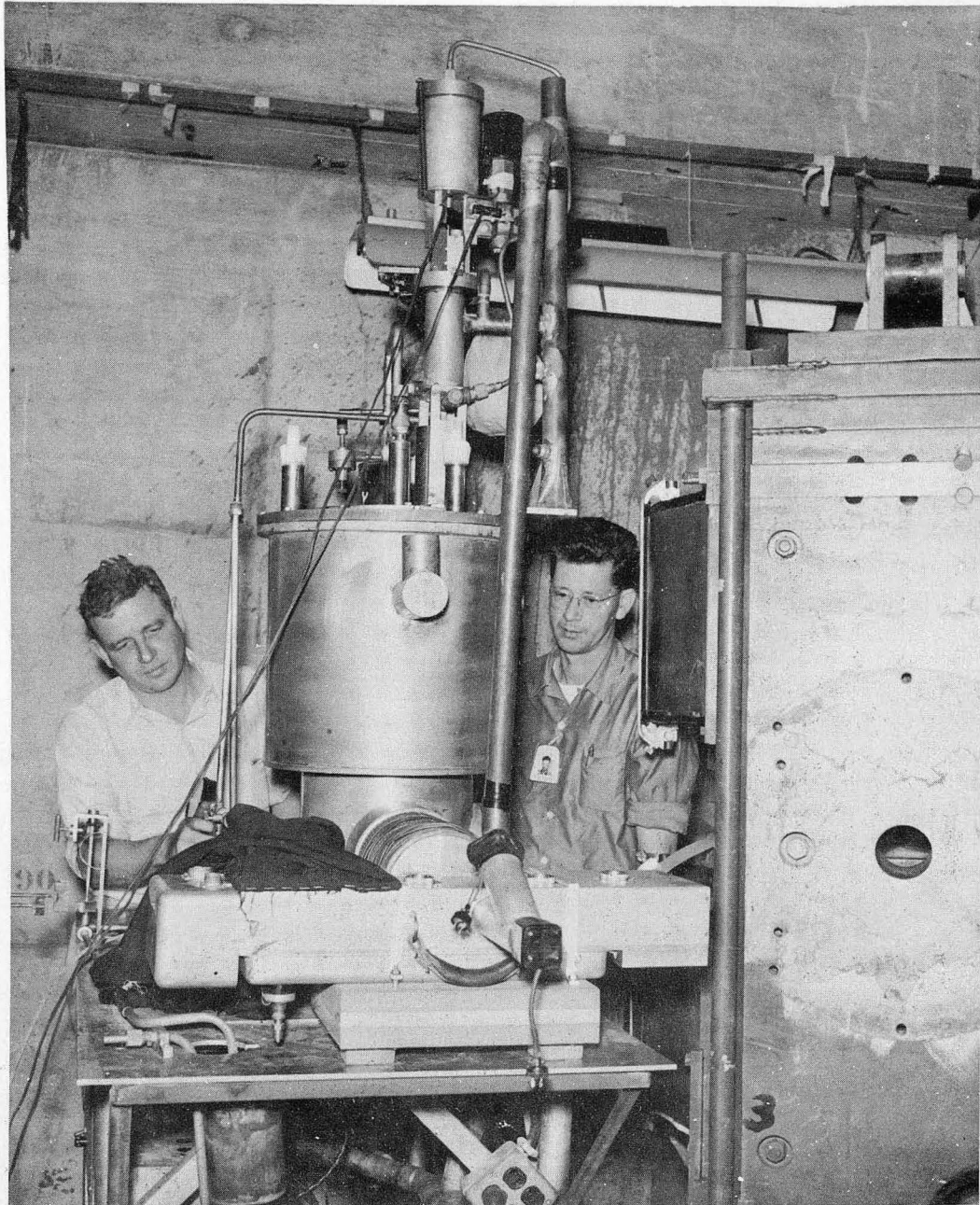

ZN-1189

Fig. 8 Cyclotron External Beam Enclosure

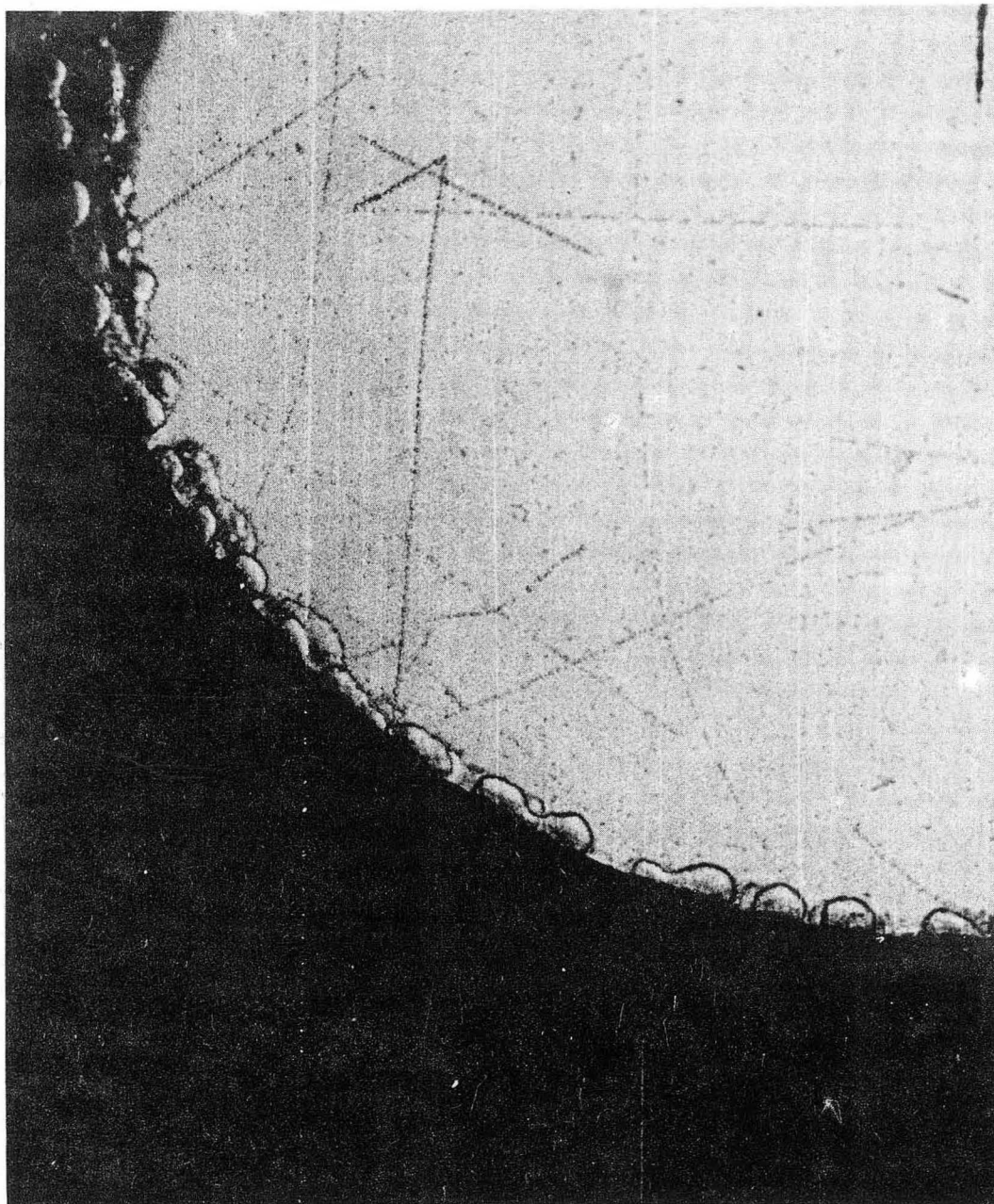

ZN-1190

Fig. 9 π - μ -Electron Decay

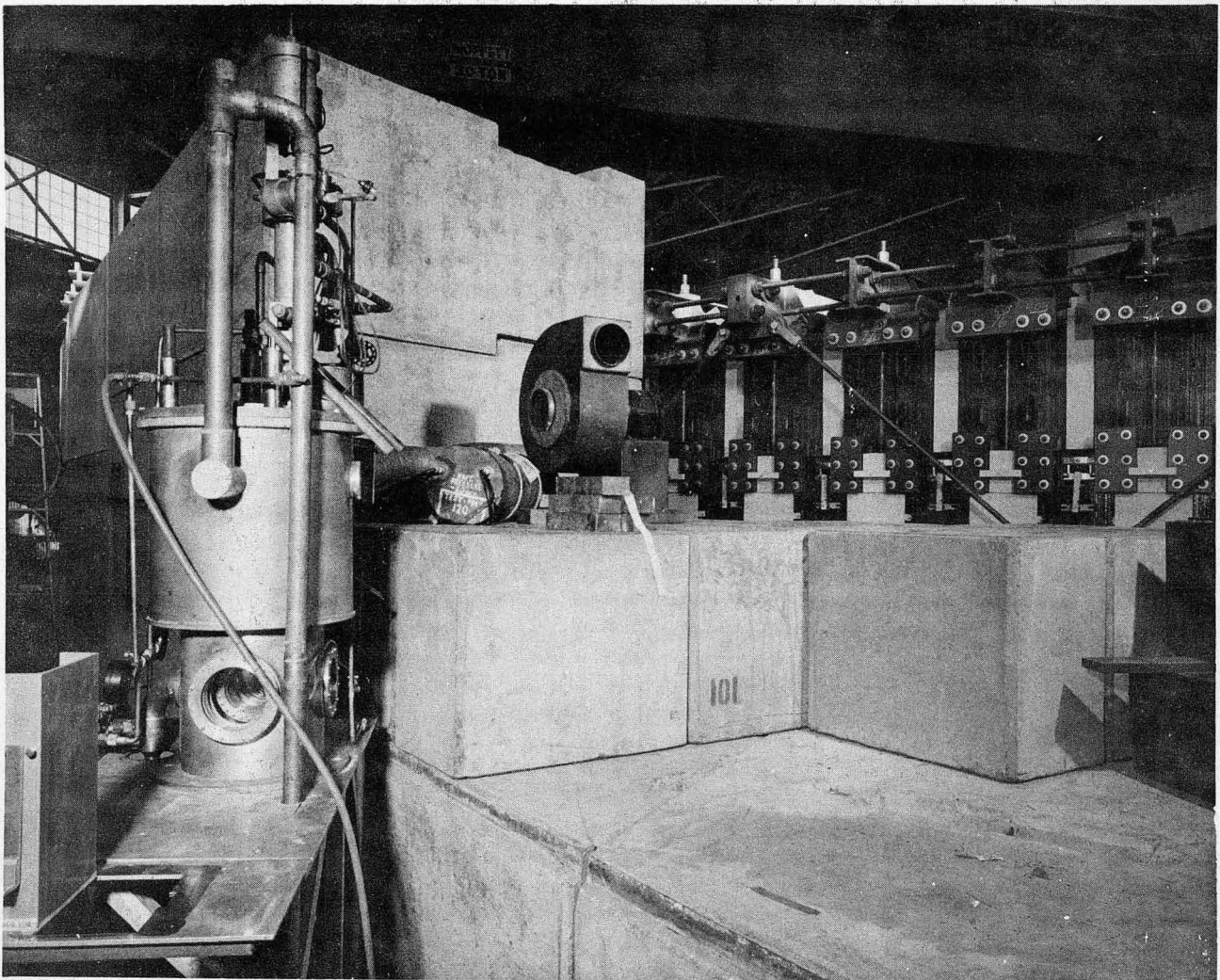

ZN-1191

Fig. 10 Bevatron Location

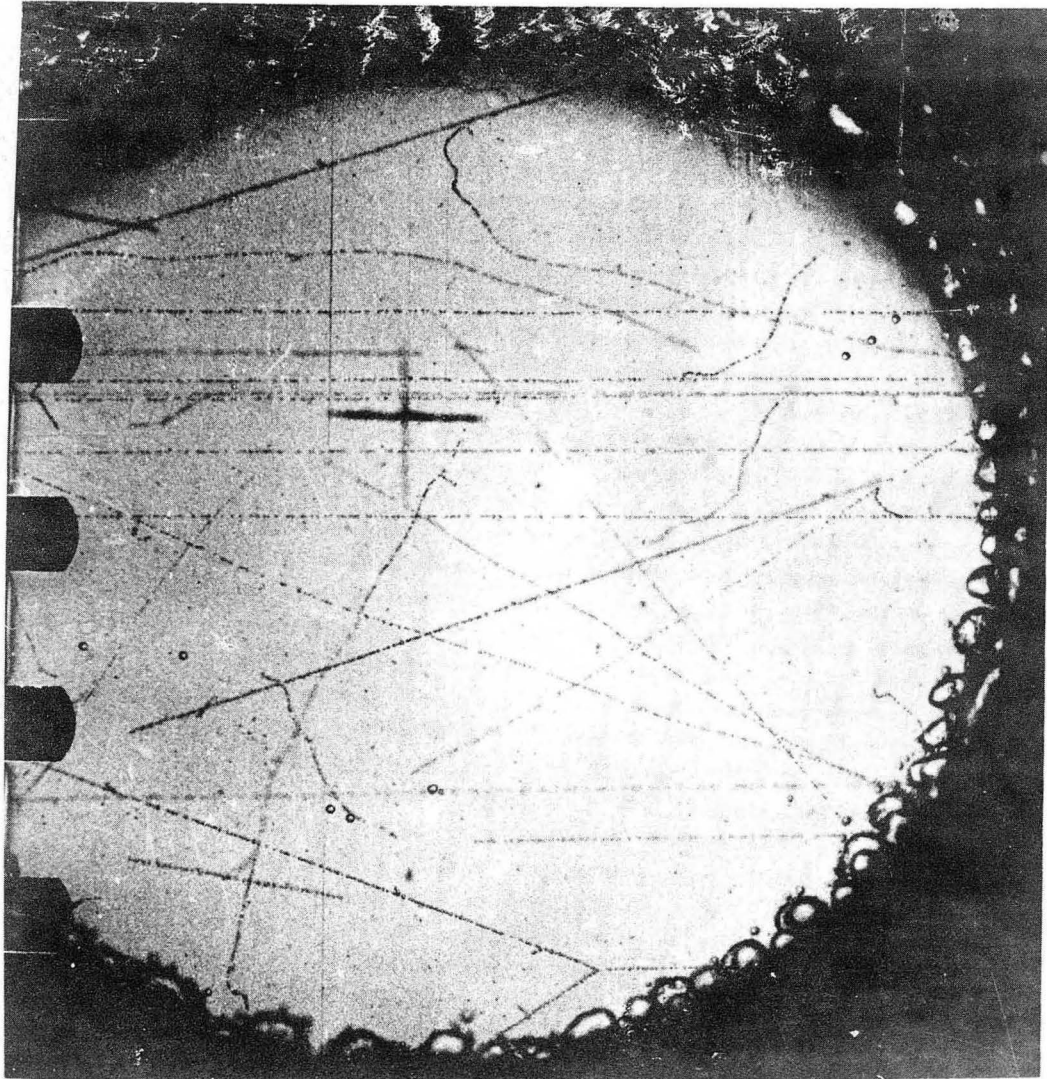

ZN-1192

Fig. 11 Bevatron Beam

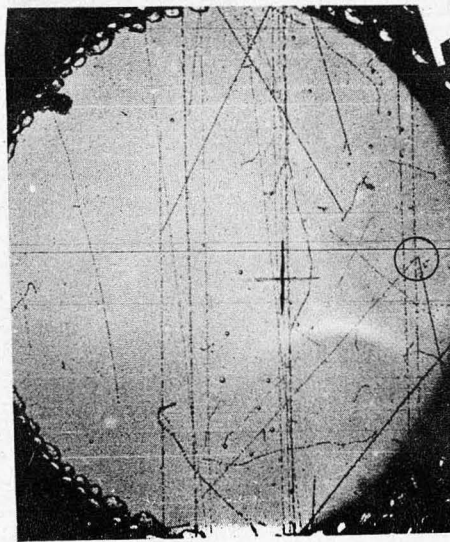
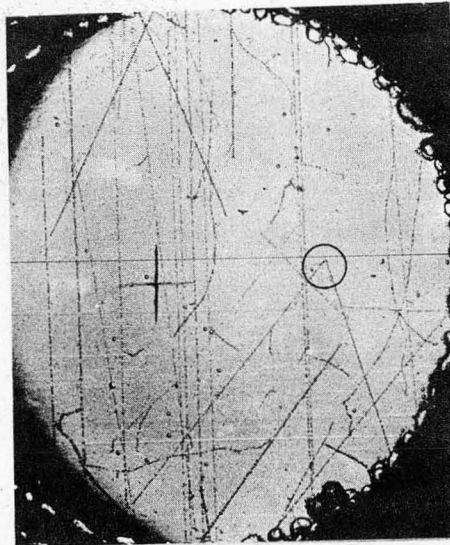

ZN-1193

Fig. 12 Shows a \wedge Event

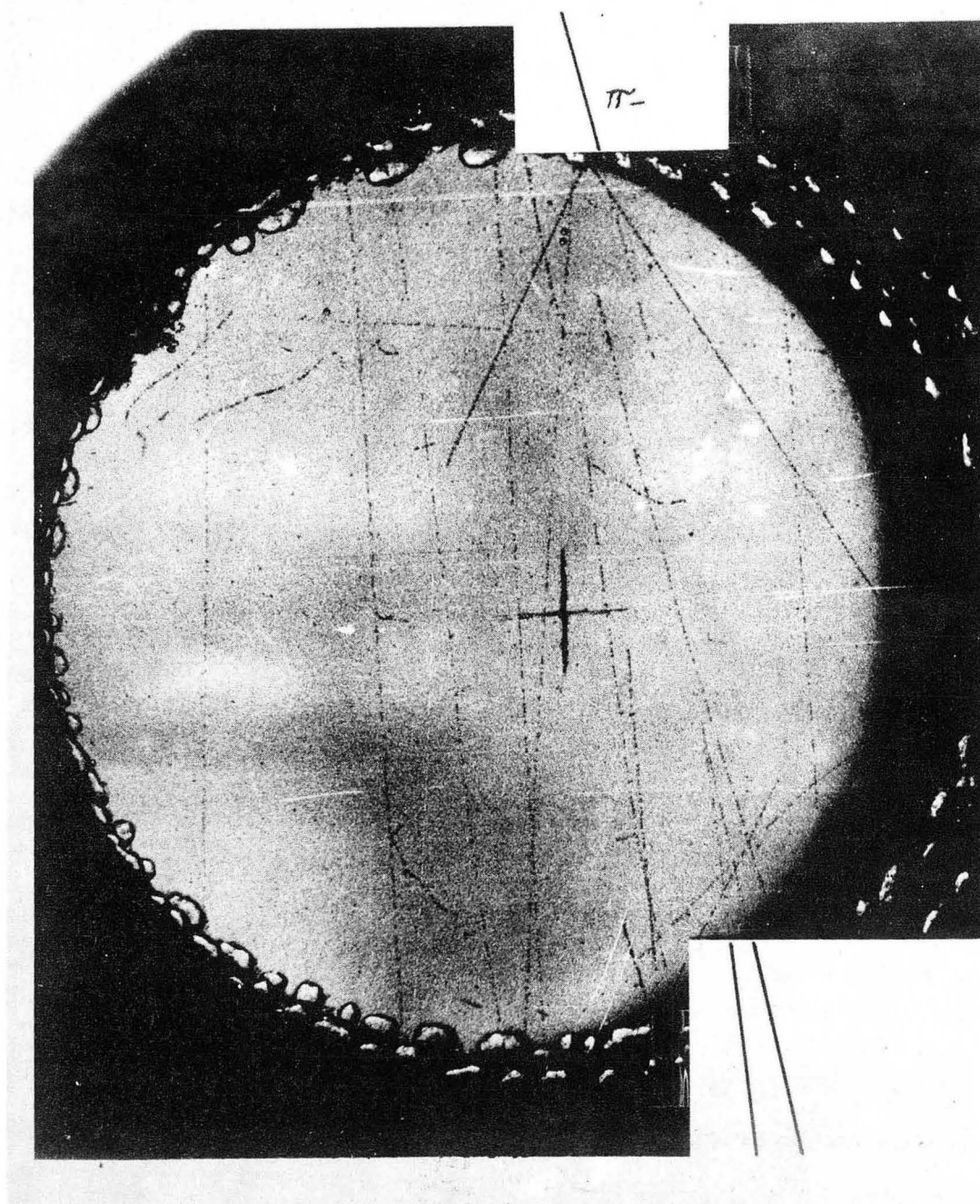

ZN-1194

Fig. 13 A Stereoscopic View of a π^- Event

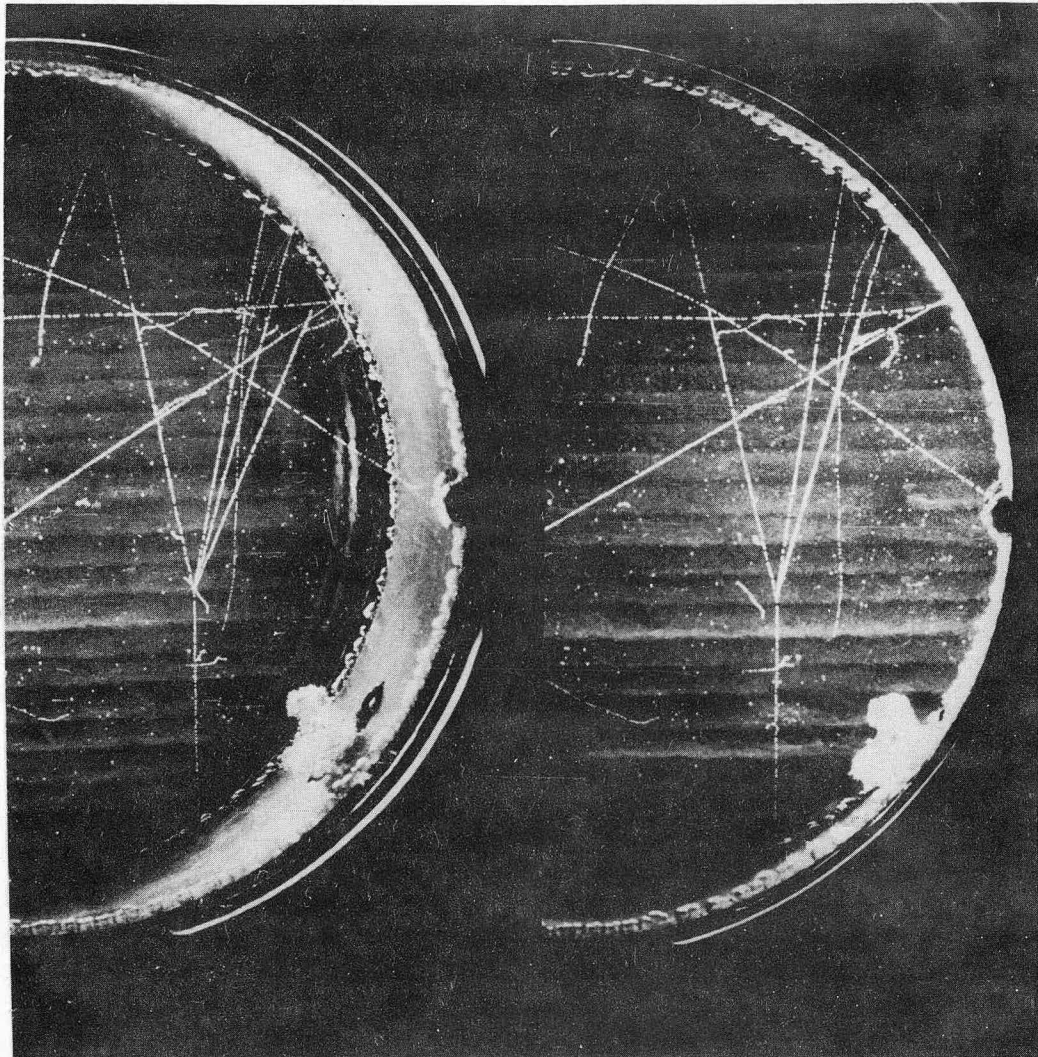

ZN-1195

Fig. 14 Shows a Stereoview of an Incident π^- Meson and the Resulting Four Prong Star Tentatively Identified as Pion Pair Production