

# Lawrence Berkeley National Laboratory

## Recent Work

### **Title**

Sodium Peroxide Fusion as an Oxidation Method in Carbon 14 Assay

### **Permalink**

<https://escholarship.org/uc/item/88g388hm>

### **Authors**

Reid, James  
Tietz, Laura

### **Publication Date**

1949-01-13

UCRL 269  
cy. 2/15

UNIVERSITY OF  
CALIFORNIA

*Radiation  
Laboratory*

TWO-WEEK LOAN COPY

*This is a Library Circulating Copy  
which may be borrowed for two weeks.  
For a personal retention copy, call  
Tech. Info. Division, Ext. 5545*

BERKELEY, CALIFORNIA

## **DISCLAIMER**

This document was prepared as an account of work sponsored by the United States Government. While this document is believed to contain correct information, neither the United States Government nor any agency thereof, nor the Regents of the University of California, nor any of their employees, makes any warranty, express or implied, or assumes any legal responsibility for the accuracy, completeness, or usefulness of any information, apparatus, product, or process disclosed, or represents that its use would not infringe privately owned rights. Reference herein to any specific commercial product, process, or service by its trade name, trademark, manufacturer, or otherwise, does not necessarily constitute or imply its endorsement, recommendation, or favoring by the United States Government or any agency thereof, or the Regents of the University of California. The views and opinions of authors expressed herein do not necessarily state or reflect those of the United States Government or any agency thereof or the Regents of the University of California.



**UNCLASSIFIED**

UNIVERSITY OF CALIFORNIA  
Radiation Laboratory

Contract No. W-7405-Eng-48

SODIUM PEROXIDE FUSION AS AN OXIDATION METHOD IN CARBON 14 ASSAY

James C. Reid and Laura Tietz

January 13, 1949

Berkeley, California

SODIUM PEROXIDE FUSION AS AN OXIDATION METHOD IN CARBON 14 ASSAY

by

James C. Reid\* and Laura Tietz

Radiation Laboratory and Department of Chemistry,  
University of California, Berkeley, California\*\*

January 13, 1949

ABSTRACT

Fusion in the peroxide bomb has been used for the combustion of organic substances in the analysis for organically bound sulfur, phosphorus, arsenic and halogens. The procedure is not suitable for carbon, partly because the blank is fairly high and is variable. For the purpose of radioactivity assay, however, it is not necessarily required that the blank be low or constant, and freed of this limitation, peroxide fusion is attractive because of the simplicity of the apparatus and operations and the rapidity with which an ignition can be performed.

---

\* Present address: National Cancer Institute, National Institute of Health, Bethesda 14, Maryland.

\*\* This paper is based on work performed under Contract No. W-7405-Eng-48 with the Atomic Energy Commission in connection with the Radiation Laboratory, University of California, Berkeley, California

SODIUM PEROXIDE FUSION AS AN OXIDATION METHOD IN CARBON 14 ASSAY

by

James C. Reid\* and Laura Tietz

Radiation Laboratory and Department of Chemistry,  
University of California, Berkeley, California\*\*

January 13, 1949

The measurement of the radioactivity of an organic substance containing Carbon 14 ordinarily involves its conversion to carbon dioxide or to barium carbonate. To effect this necessary oxidation, various workers have used Liebig combustion, (1) Van Slyke-Folch "wet" combustion (2) and persulfate "wet" combustion. (3) The purpose of this communication is to draw attention to the use of sodium peroxide fusion as a method of combustion.

---

\* Present address: National Cancer Institute, National Institute of Health, Bethesda 14, Maryland.

\*\* This paper is based on work performed under Cont. No. W-7405-Eng-48 with the Atomic Energy Commission in connection with the Radiation Laboratory, University of California, Berkeley, California.

- (1) a. D. Rittenberg in "Preparation and Measurement of Isotopic Tracers," Edwards Bros., Ann Arbor, Michigan (1947), p. 40.  
b. W. G. Dauben, J. C. Reid and P. E. Yankwich, *Anal. Chem.*, 19, 828 (1947).
- (2) a. H. E. Skipper, C. E. Bryan, L. White, Jr., and O. S. Hutchison, *J. Biol. Chem.*, 173, 371 (1948); A. Lindenbaum, J. Schubert and W. D. Armstrong, *Anal. Chem.*, 20, 1120 (1948).  
b. O. K. Neville, *J. Am. Chem. Soc.*, 70, 3499 (1948).
- (3) a. H. G. Wood, R. W. Brown, C. H. Werkman and C. G. Stuckwisch, *J. Am. Chem. Soc.*, 66, 1812 (1944).  
b. O. L. Osburn and C. H. Werkman, *Ind. Eng. Chem., Anal. Ed.*, 4, 421 (1932).  
c. S. Weinhouse, G. Medes and N. F. Floyd, *J. Biol. Chem.*, 158, 411 (1945).
-

Fusion in the peroxide bomb has been used for the combustion of organic substances in the analysis for organically bound sulfur, (4) phosphorus, (4) arsenic (5) and halogens. (6) The procedure is not suitable for the determination of carbon, partly because the blank is fairly high and is variable. For the purpose of radioactivity assay, however, it is not necessarily required that the blank be low or constant, and freed of this limitation, peroxide fusion is attractive because of the simplicity of the apparatus and operations and the rapidity with which an ignition can be performed.

#### EXPERIMENTAL

Apparatus. The micro peroxide bomb 2302 supplied by the Parr Instrument Company has a volume of 2.5 cc. and accommodates 75 mg. of organic material, although samples as small as 60 mg. can be reliably burned. The charge cannot be reduced indefinitely, for if there is too much free volume, particles of the sample may escape contact with the oxidant and combustion will be incomplete. Equally important, the thermal inertia of the bomb becomes relatively greater as the charge becomes smaller, and the increased dissipation of heat prevents the mixture from deflagrating properly. Conditions must be such that deflagration occurs, for the momentary high temperature produced by the flask is necessary to insure that combustion is quantitative. It is not possible to bring the charge to the necessary temperature by heating the bomb

- 
- (4) A. Elek and D. W. Hill, J. Am. Chem. Soc., 55, 3479 (1933).  
(5) F. E. Beamish and H. L. Collins, Ind. Eng. Chem., Anal. Ed., 6, 379 (1934).  
(6) F. E. Beamish, Ind. Eng. Chem., Anal. Ed., 6, 352 (1934).

externally, for this would melt the lead gasket. Consequently, if it is desired to burn small samples, sugar is added to bring the total amount of organic material to 75 mg. The addition of sugar dilutes the radioactive carbon and if this entails an unacceptable increase in the counting time a bomb smaller than the Parr bomb is necessary. The design of such a bomb, which has been found useful in this laboratory, is shown in Fig. 1. It accommodates 5 mg. of organic sample.

Procedure with the Parr Bomb. Fig. 1 which describes the smaller bomb serves equally well to illustrate the operation of the Parr bomb. The bomb is charged in the standard way (7): into the cup is placed about 225 mg. of powdered potassium nitrate or perchlorate, then the dry, finely divided sample and powdered sugar, if necessary, to make a total of 75 mg., and finally 1.5 g. of calorific grade sodium peroxide, which must be in good condition. If the sample is in chunks, the combustion is not reliable unless a considerable portion of the charge is made up of powdered sugar. In general, all the components of the charge should be as finely divided as possible. It is also important to mix them thoroughly before ignition.

If the sample is small enough to require the use of a micro-balance, it is most conveniently weighed into a small cup made from a 1 cm. square of thin aluminum foil. Such a cup weighs 1.5-3 mg. The top of the cup is then closed with forceps. A full charge (75 mg.) of sugar is used and the aluminum is completely oxidized in the ignition.

---

(7) Manual 116, Parr Instrument Company, Moline, Illinois.

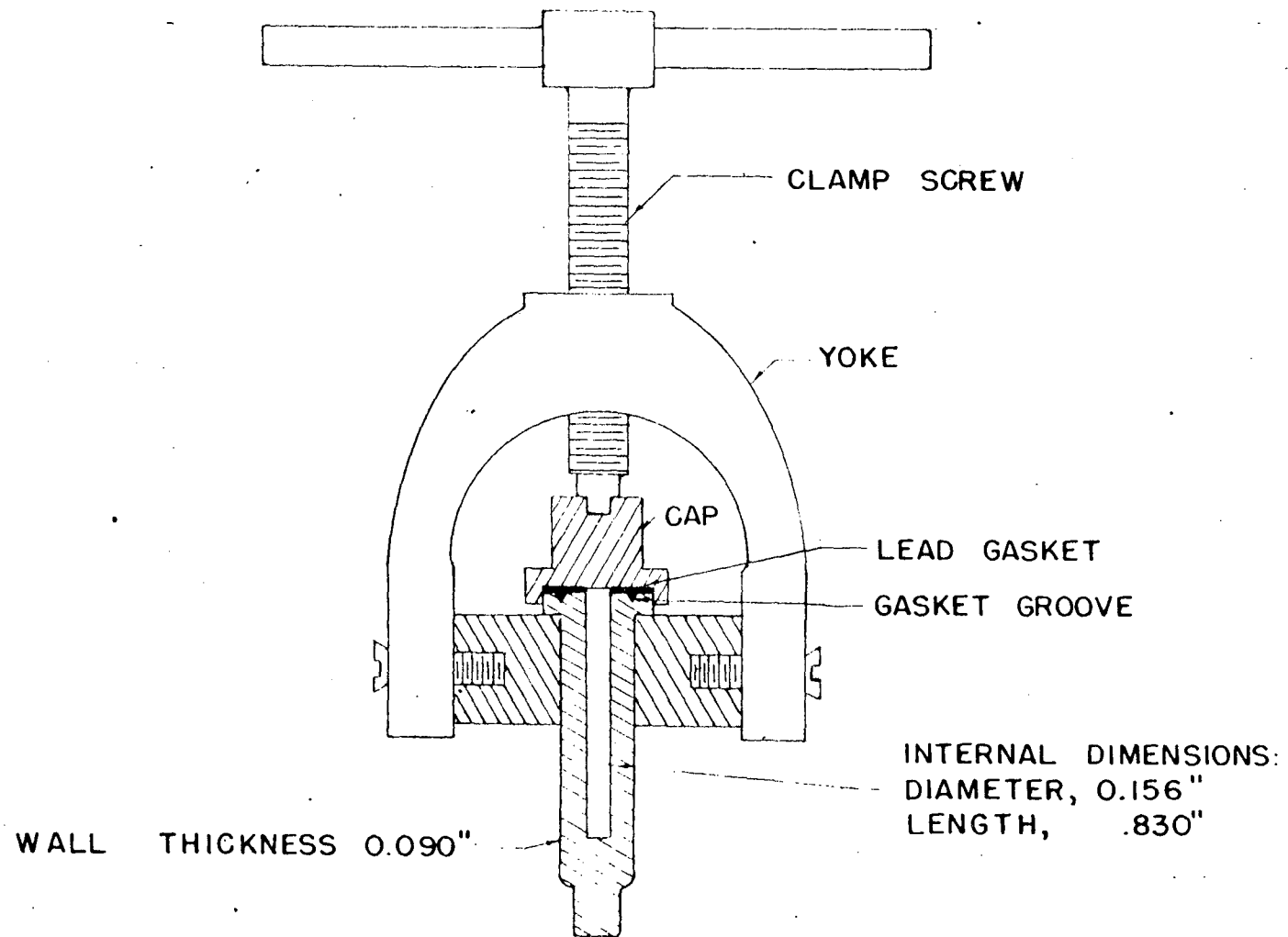

FIG. 1 SMALL PEROXIDE BOMB

If the sample is an organic liquid it is weighed into a small capillary glass ampule (7) which is placed in the bomb along with a charge of sugar. The sample should not exceed 15 mg. Peroxide ignition has not been used routinely in this laboratory for assaying liquid compounds, but a single experiment has been made to test the feasibility of the method (see Table I). Samples which require the use of foil or an ampule cannot be burned in the smaller bomb.

After the bomb has been assembled, it is thoroughly shaken to mix the contents, then tapped sharply on the bench to compact them. The charge is ignited by holding the bomb with tongs in the needle flame of an oxygen-gas burner, which is directed on the bottom of the bomb. The bomb is heated until a slight jar is felt (sometimes it is imperceptible), then 10 seconds longer; it is then allowed to cool 90 seconds in air, quenched in water and dried with a towel. The use of a small hot oxygen-gas flame gives more reliable ignition than a Bunsen burner.

It is good practice to perform the ignition behind a safety shield. As an additional precaution, fusion cups are thrown away when they have lost 1% of their initial weight.

The bomb is opened and the cap is rinsed with hot distilled water which is caught in a small beaker. The bomb is then placed in the beaker and the melt is allowed to dissolve. The beaker is provided with a cover glass to catch spray carried up by the bubbles of oxygen which form as excess peroxide reacts with the water. About 5 minutes is required for the melt to dissolve completely. The solution obtained contains a small amount of black nickelic oxide, which is removed by filtering the solution through a small sintered glass funnel into a 125 ml. Erlenmeyer flask. This operation is conveniently performed with a bell-jar vacuum

-7-

filtration apparatus. The bomb and the cover glass are carefully rinsed with hot distilled water. To the filtered solution, which should not be noticeably warm, is added 15 ml. of 40% formalin to reduce excess peroxide. The formaldehyde is oxidized to formate, and under the conditions specified there is little or no conversion of formate to carbonate. The excess peroxide must be destroyed in order to prevent the precipitation of barium peroxide when barium chloride is added.

The flask is stoppered, loosely, since hydrogen is evolved. After 15 minutes, the carbonate is precipitated by the addition of 2.5 ml. of ammonium chloride solution (300 g. per liter) and 5 ml. of barium chloride (300 g. per liter). The barium carbonate is collected on a weighed sintered glass funnel (Corning C porosity) where it is washed, dried and weighed.

Procedure with the Smaller Bomb. Into the bomb are placed in turn 15 mg. of ground potassium nitrate or perchlorate, 5 mg. of ground organic sample, or sample and sugar, and 150 mg. of calorific grade sodium peroxide. (It is particularly important to grind the sample and mix the charge well when the small bomb is used.) The bomb is placed in the clamp, and after the contents have been mixed and compacted they are ignited in a small hot oxygen-gas flame. The bomb is held in such a way that the flame plays on the solid extension at the bottom; if it is heated higher up, the lead gasket may melt. Since it is impossible to feel any disturbance when the ignition occurs, a standard heating schedule is adopted:

|            |  |
|------------|--|
| 0 seconds  | in flame                                     |
| 10 seconds | fusion should have occurred                  |
| 13 seconds | bottom of bomb bright red; remove from flame |
| 20 seconds | return to flame                              |
| 25 seconds | bottom of bomb bright red; remove from flame |
| 90 seconds | quench under tap                             |

-8-

A good fusion is indicated by a large decrease in volume and the absence of any granules of unchanged sodium peroxide. Barium carbonate is obtained from the melt in the same way as for the Parr bomb, using 1.5 ml. of formalin and corresponding amounts of ammonium chloride and barium chloride.

Illustrative results obtained with various labeled compounds are listed in Table I.

Table I  
Reproducibility of Activity Determinations Made by Peroxide Ignition

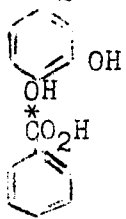
| Compound  | Specific Activity<br>cpm/mg. | Mean Deviation<br>as % of Mean | Carbon Recovery<br>as % of Theoretical |
|---|------------------------------|--------------------------------|--|
| Smaller bomb:   |                              |                                |  |
| $\text{CH}_3^*\text{CO}_2\text{Na}$   | 317                          | 1.3                            | 115                                    |
|   | 325                          |                                | 120 (a)                                |
| $^*\text{CH}_3\text{CO}_2\text{Na}$   | 5200                         | 0.86                           | 121                                    |
|   | 5210                         |                                | 120                                    |
| Melanin*  | 20.0                         | 0.50                           | 126                                    |
|   | 19.8                         |                                |  |
| Parr bomb:  |                              |                                |  |
| $\text{H}_2\text{NCH}_2^*\text{CO}_2\text{H}$                                       | 375,000                      | 0.48                           | --- (b)                                |
|   | 379,090                      |                                |  |
| $^*\text{CH}_2\text{CH}(\text{NH}_2)\text{CO}_2\text{H}$                            | 180,000                      | 0.28                           | ---                                    |
|   | 181,000                      |                                |  |
|  | 153                          | 0.33                           | 102                                    |
|   | 154                          |                                | 104                                    |
|   | 149 (c)                      | 0.67                           | ---                                    |
|   | 151                          |                                |  |
| $\text{CH}_3(\text{CH}_2)_4\text{CH}^*\text{=CH}_2$                                 | 241                          | 1.2                            | ---                                    |
|   | 247                          |                                |  |
|   | 235                          | 0.64                           | 98.35                                  |
|   | 238 (d)                      |                                | 98.07                                  |

- (a) The carbon recovery runs high by an amount ordinarily a little greater than that found in blank determinations.
- (b) Theoretical carbon recovery was not calculated because sugar, which was weighed only roughly, was added.
- (c) The same benzoic acid burned by micro Liebig combustion.
- (d) The same n-heptene burned by micro Liebig combustion.

- - - - -

#### DISCUSSION

Calculation of Results. It has been mentioned that in combustion of a sample for Carbon 14 assay it is not necessary to know the blank. This fact may be illustrated by an example: Suppose that 15.4 mg. of sample is mixed with sugar and burned. The barium carbonate obtained weighs 576 mg. Radioactivity shows that the specific activity of the barium carbonate is 18.6 cpm/mg. Since the total activity of the organic sample must equal the total activity of the barium carbonate formed from it, total activity of sample =  $576 \times 18.6$  cpm; specific activity =  $576 \times 18.6 / 15.4 = 696$  cpm/mg.

Effect of Elements Other Than Carbon. In the fusion, carbon is converted to sodium carbonate, from which it is recovered as barium carbonate. Elements other than carbon in the sample which form soluble barium salts have no interfering effect. Sulfur and phosphorus cause precipitation of sulfate and phosphate along with the barium carbonate. If the activity of the sample is measured by solid sample technique, the presence of sulfur and phosphorus introduces no error into the count values provided the radioactivity is uniformly distributed through the solid; this is true because the mass absorption coefficients for the beta rays of Carbon 14 will be about the same for barium carbonate, phosphate and

sulfate. (The specific activity of the precipitate is, of course, lowered by the impurity, but since the total weight is increased in the same proportion, the calculated value of the total and specific activity of the organic sample is not affected.) When the amounts of sulfate and phosphate are reasonably small, of the order of those found in animal tissues for instance, the error caused by inhomogeneity is inappreciable, but with larger amounts the errors caused by inhomogeneity of the mounted sample and by unrepresentative sampling would become significant.

If the activity measurement is made on gaseous carbon dioxide, the effect of inert impurities will depend on the method of filling the assay chamber. If the carbon dioxide is swept quantitatively into the chamber, the correct total activity is obtained and there is no error. In another method commonly used to fill the chamber, the carbon dioxide is not transferred quantitatively; some remains in the filling manifold. When used in this way, the chamber is calibrated in terms of the specific activity of the sample. Under these circumstances, the chamber reading gives the true specific activity of the barium carbonate, but this value is multiplied by a total weight which is too large by an amount equal to the weight of the inert impurity. Consequently, the total (and specific) activity of the organic sample is too high. However, it is often the case that the active carbonate sample is too small to furnish enough carbon dioxide to fill the chamber to the desired pressure. The deficiency may be remedied by adding a sufficient (known) amount of inactive barium carbonate to the sample before generation of the gas; when this is done, the error caused by inert impurities is reduced by an amount related to the reduction of their percentage in the mixed sample. More exactly,

$$\text{Activity}_{\text{apparent}} = \text{Activity}_{\text{true}} \left( 1 + \frac{\text{wt. impurity}}{\text{total wt. BaCO}_3} \right)$$

Evaluation of the Method. Peroxide fusion has the virtues of speed and of simplicity of the apparatus and operations. Little laboratory space is required for the equipment.

The packed tube of the Liebig combustion method is absent and the reaction product is soluble; consequently, the possibility of cross contamination of successive samples is minimized. The possibility of obtaining analytical values for the carbon and hydrogen content of a sample by the same combustion which is used to prepare it for isotope assay is sacrificed.

The method cannot be used to oxidize aqueous solutions or wet samples.

Whether elements other than carbon which precipitate with barium carbonate introduce errors into the assay values depends on the method of assay used. In many situations, such errors are not important.

The size of sample accommodated is in the range below 75 mg. The use of larger bombs has not been investigated.

Specimens which cannot be finely divided, such as fatty tissues, are reliably burned only in the presence of an easily combustible substance such as sugar. If the specific activity of the sample is low, the dilution thereby entailed may increase the counting time objectionably when solid sample technique is used. On the other hand, in large capacity instruments such as ionization chambers the dilution may not affect the counting time.

The procedure is recommended as a convenient way to burn large numbers of samples when the utmost accuracy is not required.