

UC Davis

Research reports

Title

Alligator Cracking Performance and Life-Cycle Cost Analysis of Pavement Preservation Treatments

Permalink

<https://escholarship.org/uc/item/893562th>

Authors

Lee, Charles
Nokes, William A.
Harvey, John T.

Publication Date

2008-10-01

November 2007
Revised October 2008

Technical Memorandum: UCPRC-TM-2007-08

Alligator Cracking Performance and Life-Cycle Cost Analysis of Pavement Preservation Treatments

Authors:

Charles Lee, William A. Nokes, and John T. Harvey

This work was completed as part of Partnered Pavement Research Program Strategic Plan Item 3.2.5:
Documentation of Pavement Performance Data for Pavement Preservation Strategies and Evaluation of Cost-
Effectiveness of Such Strategies

PREPARED FOR:

California Department of Transportation
Division of Research and Innovation
Office of Roadway Research

PREPARED BY:

University of California
Pavement Research Center
Davis and Berkeley



DOCUMENT RETRIEVAL PAGE**Technical Memorandum No.:**
UCPRC-TM-2007-08**Title:** Alligator Cracking Performance and Life-Cycle Cost Analysis of Pavement Preservation Treatments**Author:** C. Lee, W. A. Nokes, and J. T. Harvey**Prepared for:**
Caltrans**FHWA No.**
CA091561B**Work Submitted**
April 23, 2008**Date:**
November 2007
Revised October 2008**Strategic Plan No:**
3.2.5**Status:**
Stage 6, final**Version No:**
2**Abstract:**

This memo describes work done to (1) develop performance estimates for pavement preservation treatments, and (2) estimate the cost-effectiveness in pavement preservation implementation. Construction project histories were collected from Caltrans, and their performance histories in terms of alligator cracking were extracted from the Pavement Condition Survey (PCS) database. The UCPRC-developed algorithm resolved the dynamic segmentation issue in the PCS data. Methodology on how to select adequate project data to use is documented. Median pavement lives to 10 percent and 25 percent Alligator B cracking for various flexible pavement treatments are estimated by means of a Kaplan-Meier estimator.

Life-cycle cost analysis (LCCA) was performed with 20-year and 35-year analysis periods to try to determine (1) whether pavement preservation should be applied, (2) when pavement preservation should be applied. LCCA could only be completed for dense-graded asphalt overlays and chip seals with conventional binders due to limitations in complete datasets that could be gathered from existing Caltrans data sources. Cost differences were compared between continuous application of pavement preservation treatments or limiting these treatments to not more than twice in between rehabilitations. Findings from the LCCA show that, in general, (1) it is more cost-effective to apply pavement preservation treatment than to only rely on rehabilitation and (2) it is more cost-effective to apply pavement preservation at earlier stages of cracking rather than later.

However, due to major limitations on the data that could be gathered for the analysis and despite the major effort by the UCPRC and by Caltrans HQ and Division of Maintenance staff, the results presented should only be considered as indications of pavement performance and life-cycle cost

Keywords: life-cycle cost analysis, pavement preservation, pavement performance, PMS Database

Proposals for implementation: 1. Use pavement preservation treatments, as opposed to using rehabilitation alone. Place pavement preservation treatments at lower levels of cracking than was the practice from 1988 to 2003, with the comparison in this study being made between treatment at less than or equal to 10 percent Alligator B cracking versus more than 25 percent Alligator B cracking. 2. Implement changes in PMS: implement system for collecting as-built information for rehabilitation and maintenance work; use fixed segmentation of network as opposed to changing segmentation from year-to-year; make recommended changes in PCS. 3. Establish pavement preservation test sections following guidelines in Pavement Preservation Strategies Technical Advisory Guide (PPSTAG). 4. Use the framework presented in this report for future LCCA evaluations of the cost-effectiveness of pavement treatments.

Related documents:

“Pavement Performance Data Extraction from Caltrans’ PMS” (UCPRC-TM-2007-06)

Work plan: “Performance Review of Pavement Preservation Treatments” (October 9, 2006). Prepared by the University of California Pavement Research Center, Berkeley and Davis, for the California Department of Transportation Division of Research and Innovation Office of Roadway Research and Division of Maintenance Office of Pavement Preservation

Signatures:

C. Lee 1st Author	W. Nokes, J. Harvey Technical Review	D. Spinner Editor	J. Harvey Principal Investigator	T. J. Holland Caltrans Contract Manager
-----------------------------	---	-----------------------------	--	---

DISCLAIMER

The contents of this report reflect the views of the authors, who are responsible for the facts and accuracy of the data presented herein. The contents do not necessarily reflect the official views or policies of the State of California or the Federal Highway Administration. This report does not constitute a standard, specification, or regulation.

ACKNOWLEDGMENTS

The Caltrans Division of Research and Innovation (DRI) Contract Manager was Michael Samadian, under the direction of Nick Burmas. The Pavement Standards Team Technical Lead was Shakir Shatnawi.

The authors would also like to acknowledge the help of the Caltrans Division of Maintenance Office of Roadway Rehabilitation, under the direction of Susan Massey, which has provided continued guidance and assistance on this project, including provision of historic construction files provided by Leo Mahserelli, Rob Marsh, Brian Webber, and Ron Jones.

PROJECT OBJECTIVES

The purpose of this project was to develop performance estimates for pavement preservation treatments following rehabilitation and to compare them with performance estimates for sections which did not receive pavement preservation treatments after rehabilitation. The performance estimates were made using condition survey data from the Caltrans Pavement Condition Survey (PCS) database and maintenance and rehabilitation construction history data obtained from Caltrans. The focus of this research was on flexible and composite (asphalt on concrete) pavements. The objectives of this work were as follows:

- Identify pavement preservation treatments in the PCS data in the Caltrans Pavement Management System (PMS) databases;
- Retrieve and review PCS data and other data from available sources in order to develop performance estimates;
- Develop condition survey performance histories;
- Perform statistical analyses to identify performance probabilities;
- Analyze timing of pavement preservation treatments in terms of extent of cracking and their effects on relative performance;
- Calculate life-cycle costs; and
- Report the results of the investigation.

CONVERSION FACTORS

SI* (MODERN METRIC) CONVERSION FACTORS				
APPROXIMATE CONVERSIONS TO SI UNITS				
Symbol	Convert From	Multiply By	Convert To	Symbol
LENGTH				
in	inches	25.4	Millimeters	mm
ft	feet	0.305	Meters	m
AREA				
in ²	square inches	645.2	square millimeters	mm ²
ft ²	square feet	0.093	square meters	m ²
VOLUME				
ft ³	cubic feet	0.028	cubic meters	m ³
MASS				
lb	pounds	0.454	Kilograms	kg
TEMPERATURE (exact degrees)				
°F	Fahrenheit	5 (F-32)/9 or (F-32)/1.8	Celsius	C
FORCE and PRESSURE or STRESS				
lbf	poundforce	4.45	Newtons	N
lbf/in ²	poundforce/square inch	6.89	Kilopascals	kPa
APPROXIMATE CONVERSIONS FROM SI UNITS				
Symbol	Convert From	Multiply By	Convert To	Symbol
LENGTH				
mm	millimeters	0.039	Inches	in
m	meters	3.28	Feet	ft
AREA				
mm ²	square millimeters	0.0016	square inches	in ²
m ²	square meters	10.764	square feet	ft ²
VOLUME				
m ³	cubic meters	35.314	cubic feet	ft ³
MASS				
kg	kilograms	2.202	Pounds	lb
TEMPERATURE (exact degrees)				
C	Celsius	1.8C+32	Fahrenheit	F
FORCE and PRESSURE or STRESS				
N	newtons	0.225	Poundforce	lbf
kPa	kilopascals	0.145	poundforce/square inch	lbf/in ²

*SI is the symbol for the International System of Units. Appropriate rounding should be made to comply with Section 4 of ASTM E380. (Revised March 2003)

TABLE OF CONTENTS

List of Tables.....	vii
List of Figures	ix
List of Abbreviations Used in the Text	x
1 Project Overview.....	1
1.1 Background and Objectives.....	1
1.2 “Data-Driven” Approach Used for the Study.....	5
1.3 Chronology of Activity.....	5
1.4 Order of Work Summary.....	6
2 Process for Selecting Usable Data.....	9
2.1 Dynamic Segmentation.....	10
2.2 Project Selection.....	14
3 Summary of Database.....	17
3.1 Initial Database of Projects.....	17
3.2 Database of Observations	18
3.2.1 Adjusting for Traffic	18
3.2.2 Adjusting for Missing Lane Prior Condition Data	19
3.2.3 Distribution of Projects and Observations by District.....	22
4 Summary of Practice 1988 to 2003	25
5 Factors influencing Performance	29
5.1 Check Correlation of Factors.....	29
5.2 Analysis of Factors	30
6 Pavement Life Results	33
6.1 Procedures Used to Develop Probability of Failure	33
6.2 Summary by Strategy and Program.....	36
6.3 Summary of Factors Affecting Performance.....	38
6.4 Annualized Pavement Treatment Costs.....	41
7 Life-Cycle Cost Analysis.....	47
7.1 Assumptions for LCCA.....	49
7.2 Factors Sensitivity Analysis	49
7.3 Attempt to Predict Pavement Performance by Linear Extrapolation.....	55
7.4 Service Life Used for LCCA	56
7.5 LCCA Scenarios.....	58
7.6 LCCA Results and Findings	63

7.6.1	LCCA Objective 1: Is It More Beneficial to Apply Pavement Preservation (HM-1) Versus No Maintenance?.....	63
7.6.2	LCCA Objective 2: Should Pavement Preservation Be Applied at an Earlier or a Later Stage of Cracking?	65
7.6.3	LCCA Objective 3: Comparison of LCC of Different Combinations of Pavement Treatments	67
8	Summary and Preliminary Conclusions	71
8.1	Tracking Pavement Preservation Projects	71
8.2	Estimated Pavement Performance	72
8.3	Life-Cycle Cost Analysis.....	73
8.4	Recommendations	75
8.3.1	Pavement Preservation Practice	75
8.3.2	Caltrans PMS Data.....	75
8.3.3	Pavement Preservation Test Sections.....	76
8.3.4	Framework for Future LCCA Evaluations of Cost-Effectiveness of Pavement Treatments	76
9	References.....	77
	Appendix A: Glossary	79
	Appendix B: Definition of Data Censoring	81
	Appendix C: Example Calculation of Probability of Failure Distribution for Figure 8.....	83

LIST OF TABLES

Table 1: Project Objectives, Deliverables, and Notes	2
Table 2: List of Deleted Project Histories	17
Table 3: Project Distribution—One Observation per Selected Project	18
Table 4: Average Lane Distribution Factor of AADTT for Highway with Different Number of Lanes in One Direction (4)	19
Table 5: Distribution of Observations (Considering Multiple Lanes and Both Directions).....	19
Table 6: Number of Observations with Missing PCS Data.....	19
Table 7: Distribution of Observations After Adjusting for Missing Prior Condition Data	20
Table 8: Distribution of Observations for Final Set of Data Used for.....	21
Table 9: Distribution of Observations for Composite Sections.....	21
Table 10: Distribution of Observations by Program Type and District.....	22
Table 11: Distribution of Observations by Strategy and District	22
Table 12: Distribution of Projects and Observations by Districts	23
Table 13: Mean Existing Cracking Levels When Each PP Strategy Performed	25
Table 14: Existing Cracking Data for Each PP Strategy and Program.....	27
Table 15: Correlation Table—Factors Affecting Pavement Performance.....	30
Table 16: Descriptive Statistics of Factors Affecting Cracking Performance in Data	31
Table 17: Statistics of Factors Affecting Pavement Performance in Data	31
Table 18: Statistics of Factors Affecting Pavement Performance in Data without MinTemp	32
Table 19: Significance Level of Temperature Factor in Pavement Performance.....	32
Table 20: Expected Life for Each PP Strategy and Program Showing Years to Failure Levels, not Pre-Existing Cracking.....	37
Table 21: ACOL-DG HM-1	38
Table 22: ACOL-DG CapM.....	39
Table 23: ACOL-DG Rehab.....	39
Table 24: ACOL-OG HM-1	39
Table 25: ACOL-RAC HM-1.....	40
Table 26: ACOL-RACO HM-1	40
Table 27: Chip Seal	40
Table 28: Digout.....	41
Table 29: Slurry	41
Table 30: ACOL-DG HM-1 Annualized Cost per Lane-Mile (x \$1,000).....	42
Table 31: ACOL-DG CapM Annualized Cost per Lane-Mile (x \$1,000).....	43

Table 32: ACOL-DG Rehabilitation Annualized Cost per Lane-Mile (x \$1,000)	43
Table 33: ACOL-OG HM-1 Annualized Cost per Lane-Mile (x \$1,000)	43
Table 34: ACOL-RAC HM-1 Annualized Cost per Lane-Mile (x \$1,000).....	44
Table 35: Chip Seal Annualized Cost per Lane-Mile (x \$1,000)	44
Table 36: Digout Annualized Cost per Lane-Mile (x \$1,000).....	44
Table 37: Slurry Annualized Cost per Lane-Mile (x \$1,000).....	45
Table 38: AADTT Sensitivity Test Table	50
Table 39: Average Annual Precipitation Sensitivity Test Table	50
Table 40: Average Annual Minimum Temperature Sensitivity Test Table	51
Table 41: Average Annual Minimum Temperature in January Sensitivity Test Table.....	52
Table 42: Average Annual Freeze-thaw Cycles Sensitivity Test Table	53
Table 43: ACOL-DG HM-1—Rural vs. Urban District Sensitivity Test Table.....	54
Table 44: ACOL-DG Rehabilitation—Rural vs. Urban District Sensitivity Test Table	54
Table 45: Median vs. Estimated ACOL-DG Rehabilitation Lives	56
Table 46: Dense-Graded Asphalt Concrete Overlay (Rehabilitation) Performance.....	56
Table 47: Dense-Graded Asphalt Concrete Overlay (CapM) Performance	56
Table 48: Rubber Asphalt Concrete Overlay (CapM) Performance	57
Table 49: Dense-Graded Asphalt Concrete Overlay (HM-1) Performance	57
Table 50: Rubber Asphalt Concrete Overlay (HM-1) Performance.....	57
Table 51: Open-Graded Asphalt Concrete Overlay (HM-1) Performance.....	58
Table 52: Chip Seal (HM-1) Performance	58
Table 53: LCCA Scenario List for Major Scenario Set No. 1	60
Table 54: LCCA Scenario List for Major Scenario Set No. 2.....	60
Table 55: LCCA Scenario List for Major Scenario Set No. 3.....	61
Table 56: LCCA Scenario List for Major Scenario Set No. 4.....	62
Table 57: LCCA Scenario List for Major Scenario Set No. 5.....	62
Table 58: LCCA Scenario List for Major Scenario Set No. 6.....	62
Table 59: LCCA Scenario List for Major Scenario Set No. 7.....	63
Table 60: LCC of Preventive vs. No Preventive Actions (Rehabilitation at >25% Alligator B Cracking)—Dense-Graded Overlay	64
Table 61: LCC of Preventive vs. No Preventive Actions (Rehabilitation at >25% Alligator B Cracking)—Chip Seal.....	64
Table 62: LCC of Preventive Treatment at Early vs. Later Stage of Cracking (Rehabilitation at >25% Alligator B Cracking)—Dense-Graded Overlay	66

Table 63: LCC of Preventive Treatment at Early vs. Later Stage of Cracking (Rehabilitation at >25% Alligator B Cracking)—Chip Seal-AC	66
Table 64: LCC of Two HM-1 vs. Unlimited HM-1 Preventive Actions (Rehabilitation at >25% Alligator B Cracking)—Dense-Graded Overlay	68
Table 65: LCC of Two HM-1 vs. Unlimited HM-1 Preventive Actions (Rehabilitation at >25% Alligator B Cracking)—Chip Seal	68

LIST OF FIGURES

Figure 1: Flowchart of project activity.....	8
Figure 2: Example of dynamic segmentation versus project limits.....	11
Figure 3: Scenario 1.....	12
Figure 4: Scenario 2.....	12
Figure 5: Scenario 3.....	13
Figure 6: Scenario 4.....	13
Figure 7: Example of project selection process (4-SM-84-PM20-PM21.5).....	16
Figure 8: Example of probability distribution for HM-1 ACOL-DG for 10 percent Alligator A cracking.	35
Figure 9: Example of probability distribution for HM-1 ACOL-DG.....	36
Figure 10: Process flowchart for LCCA.....	48
Figure 11: Example of pavement life prediction using linear regression.....	55

LIST OF ABBREVIATIONS USED IN THE TEXT

AAC cracks	Alligator A cracks
ABC cracks	Alligator B cracks
ACOL	Asphalt Concrete Overlay
AADTT	Average Annual Daily Truck Traffic
ACOL-DG	Dense-graded asphalt concrete overlay
ACOL-OG	Open-graded asphalt concrete overlay
ACOL-RAC	Rubberized asphalt concrete
ACOL-RACO	Rubberized asphalt concrete open-graded
CapM	Treatments performed under Caltrans' Capital Preventive Maintenance Program
ChipSeal-AC	Chip seal with conventional asphalt or emulsion
ChipSeal-AR	Rubberized asphalt concrete chip seal
ChipSeal-PMA	Polymer-modified asphalt concrete chip seal
ChipSeal-PME	Polymer-modified emulsion asphalt concrete chip seal
EUAC	Equivalent Uniform Annual Cost
EA	Expenditure Authorization (Caltrans)
HM-1	Treatments performed under Caltrans' Contract Highway Maintenance Program
LCCA	Life-cycle Cost Analysis
PP	Pavement Preservation

1 PROJECT OVERVIEW

1.1 Background and Objectives

The Division of Maintenance of the California Department of Transportation (Caltrans) has identified a need to compare the estimated performance of asphalt pavements that have undergone preservation treatments with those that haven't. This is a first step necessary to compare the life-cycle costs of various pavement preservation treatments with each other, and with "control" cases meaning pavements where no preservation treatment has been applied.

The University of California Pavement Research Center (UCPRC) has been working on Partnered Pavement Research Center Strategic Plan Element 3.2.5 (PPRC SPE 3.2.5), titled "Documentation of Pavement Performance Data for Pavement Preservation Strategies and Evaluation of Cost-Effectiveness of Such Strategies," since October 2005. The goal of PPRC SPE 3.2.5 is to use performance prediction to recommend best pavement preservation practices, and the original objectives of PPRC SPE 3.2.5 are:

- a. To track pavement preservation projects through performance databases;
- b. To estimate pavement performance for various strategies and application times relative to condition of the existing pavement; and
- c. To analyze life-cycle costs and recommend optimum timing and strategy selection.

In July 2006 the Division of Maintenance provided an additional \$50,000 to the Division of Research and Innovation for the UCPRC to increase the scope of this research and to overcome problems in completing the original objectives. The revised project objectives are as follows:

- a. To identify pavement preservation treatments in the Caltrans Pavement Condition Survey (PCS) data in the Caltrans Pavement Management System (PMS) databases;
- b. To Retrieve and review PCS data and other data from available sources in order to develop performance estimates;
- c. To develop condition survey performance histories;
- d. To perform statistical analyses to identify performance probabilities;
- e. To analyze timing of pavement preservation treatments and their effects on relative performance;
- f. To calculate life cycle costs; and
- g. To report the results of the investigation.

The revised objectives are stated in the “Work Plan for Performance Review of Pavement Preservation Treatments” (1). Each objective, its associated deliverable, and notes regarding their completion are presented in Table 1.

By extracting and analyzing the best possible information already in the Caltrans databases, it is expected that present pavement preservation practices can be improved. This included documenting past practice for pavement maintenance, and comparison with a “pavement preservation” approach to pavement maintenance. Pavement preservation seeks the best use of maintenance resources through optimization of the selection and timing of application of maintenance treatments by use of performance estimation and life-cycle cost analysis.

Table 1: Project Objectives, Deliverables, and Notes

Objective	Deliverables	Report Section	Notes
Identify pavement preservation treatments.	List of pavement preservation (PP) treatment sections constructed 1993 to 2002; summary of gaps in the available data.	2.1, 2.2, 3.1	11 PP strategies, mostly ACOL-DG.
Retrieve and review PCS data and other data.	Database of pavement performance data (condition survey) extracted from Pavement Condition Survey and containing traffic and climate data.	3.1, 3.2, database and UCPRC-TM-2007-06	Database created containing data for performance, climate, and truck traffic. Cost data collected based on past Caltrans M&R projects.
Develop condition survey performance histories.	Summary memorandum of pavement performance histories for sections in database.	2.2 and UCPRC-TM-2007-06	Plotted 2,500 project sections (5,000 plots).
Perform statistical analysis to identify performance probabilities.	Summary memorandum of statistical analysis of pavement performance for sections in database.	4, 5, 6.1–6.3	718 project sections were adequate after visual inspection. Visual inspection showed performance history did not meet criteria on 1,800 sections. Probability of failure for the pooled dataset complete for ACOL-DG based on Alligator A+B cracking. Developing refined probabilities based on

Objective	Deliverables	Report Section	Notes
			traffic/climate factors.
Calculate life-cycle costs.	Summary memorandum of calculated life-cycle costs for pavement preservation treatments and control sections included in statistical analysis of performance.	6.4	Complete.
Analyze timing and relative performance.	Summary memorandum of historical maintenance patterns and estimated optimum timing of pavement preservation treatments based on life-cycle cost analysis.	7	Complete.
Report.	Report summarizing all the work completed.	This report	Complete

With the additional funding, data was collected for a larger number of pavement preservation treatments in the PCS database as well. The objectives were completed by the UCPRC working with the Division of Maintenance Office of Pavement Preservation (OPP), with assistance from the Office of Roadway Rehabilitation and the Office of Roadway Maintenance.

As of October 2006 it had been determined that the primary difficulties with completing the project were those of extracting performance data from the Caltrans PCS database due to dynamic segmentation, finding information regarding underlying pavement structures, and finding histories of rehabilitation and maintenance necessary to explain the condition survey data.

By October 2006 the problem of dynamic segmentation had largely been solved by developing an algorithm that appropriately weights condition survey data across the various annual network segmentations included in the PCS database. The solution to extracting cracking data collected under dynamic segmentation from the PCS database is documented in the technical memorandum titled “Pavement Performance Data Extraction from Caltrans’ PMS” (UCPRC-TM-2007-06).

To solve the problem of lack of underlying structure information, a set of more than 300 sections was created that consists of pavements that have been cored and/or evaluated with ground-penetrating radar (GPR) to determine pavement layers and thicknesses. This set includes flexible, rigid, and composite

(concrete overlaid with asphalt) pavements. The results of the GPR study are presented in the report titled “Pilot Project for Fixed Segmentation of the Pavement Network” (UCPRC-RR-2005-11). The condition survey data for these sections have been extracted from the PCS database for the period of 1978 to 2004, and performance curves for important surface distresses have been developed.

The problem of finding maintenance and rehabilitation histories to identify pavement preservation treatments applied or not applied was solved by working with regional maintenance coordinators from the Caltrans Office of Roadway Rehabilitation to match project construction histories in the databases they had personally developed with the condition survey data organized by the UCPRC. A set of specific questions regarding maintenance and rehabilitation histories was created by the UCPRC after review of the distress performance curves for each section in the set. The list of questions was submitted to the Division of Maintenance Office of Roadway Rehabilitation in August 2006. The regional Maintenance advisors answered as many of these questions as they could with their existing databases in September 2006 and in follow-up meetings.

Performance estimates were then developed, using the data for flexible and composite pavement, rehabilitation, and pavement preservation treatments for the sections for which construction histories can be found. These performance estimates were to be used to compare life-cycle costs of rehabilitation projects with and without pavement preservation treatments following the procedure recently developed by the UCPRC and the Division of Design, based on the Federal Highway Administration software *RealCost*. Only those segments with good cracking condition survey trends, and for which the condition survey trends were reasonable with respect to maintenance and rehabilitation construction records, were used for the final performance estimates. The details of the data extraction and the numbers of sections with data used for these analyses are documented in UCPRC-TM-2007-06.

This technical memorandum is the final report completing the revised objectives and it is one part of the documentation to be delivered under Strategic Plan Element 3.2.5 of the PPRC, which includes “documentation of pavement performance data for pavement preservation strategies and evaluation of cost-effectiveness of such strategies.”

1.2 “Data-Driven” Approach Used for the Study

A key point embedded in the objectives for this project is that the performance estimates and resultant life-cycle cost estimates and recommendations be “data-driven,” using pavement condition and construction information in order to develop empirical probabilities of pavement performance and to analyze life-cycle costs. No attempt was made to apply “expert judgment” where data was not available or not consistent with expectations. This approach was applied for two reasons. First, no judgment was applied to the data so as not to bias the life-cycle cost analysis. Second, it was desired that “expected results” based on common wisdom and judgment be tested with actual performance data, both to review whether our expectations were verified by the data and to identify problems with using Caltrans’ current databases to provide good performance data useable for life-cycle cost analysis.

Adequate resources were applied to this process to attempt to complete the objectives. The results should be considered to be close to the best information that can be extracted from the current PCS database.

1.3 Chronology of Activity

A timeline showing research activities and deliverables is shown below.

September to November 2006

- Requested pavement preservation (PP) project information from Caltrans HQ and District offices.
- Collected information for approximately 2,500 PP projects (project dates from 1992 to 2003). Many projects were missing information.
- Continued making requests for project information from HQ and Districts continued into early June 2007. Help from S. Massey and District reviewers at Caltrans HQ Maintenance was essential. They spent many hours meeting with UCPRC, answering questions, checking their databases, and giving recommendations.

November to December 2006

- Extracted Pavement Condition Survey (PCS) data.
- Applied UCPRC algorithm to correct for dynamic segmentation.
- Identified 2,400 projects from 1988 to 2003 with sufficient information for data extraction.
- Chose the type of PP strategy for the list of projects.

February 2007

- Created PCS history plots for the 2,400 projects.
- Produced plots showing time versus Alligator A, Alligator B, Alligator A+B, and IRI (International Roughness Index) for each project section. IRI was not used due to problems with the data.

May 2007

- Performed labor-intensive, visual inspection of the PCS plot vs. project history for every project (all 2,400) to confirm application of PP strategy.
- Selected usable project data for developing performance probability.
- Identified reason that section data was not usable (history mismatch, duplicate section, insufficient history).
- Applied lane distribution factors; 718 projects became 1,421 observations.

June to July 2007

- Developed cumulative probability distributions.
- Delivered draft summary memo.

August to November 2007

- Performed life-cycle cost analysis.
- Delivered technical memo.
- Delivered database used in project to Caltrans Division of Maintenance.

1.4 Order of Work Summary

Work performed in this study consisted of three main parts: data processing, statistical analysis, and life-cycle cost analysis (LCCA).

Data processing: This involved using data from the Caltrans Pavement Condition Survey database to produce historical information about pavement performance. Section 2 through Section 5 describe in detail the work performed to compile the database of useful historical pavement information.

Statistical analysis: Based on data collected from the preceding process, the Kaplan-Meier estimator from a statistical survival model is used to generate the pavement's probability of failure over time. The life of

the pavement is then defined as the year when over half the sample population fails. Section 6 presents the expected pavement life determined for different pavement treatments.

Life-cycle cost analysis: With available information on pavement life, LCCA is performed for different scenarios of pavement maintenance sequences to determine life-cycle costs of pavement preservation. A detailed description of steps for the LCCA and an interpretation of results are presented in Section 7.

Figure 1 presents a flowchart of all processes done to complete this study. The flowchart includes a more comprehensive presentation of the specific tasks performed along each of the three main process categories.

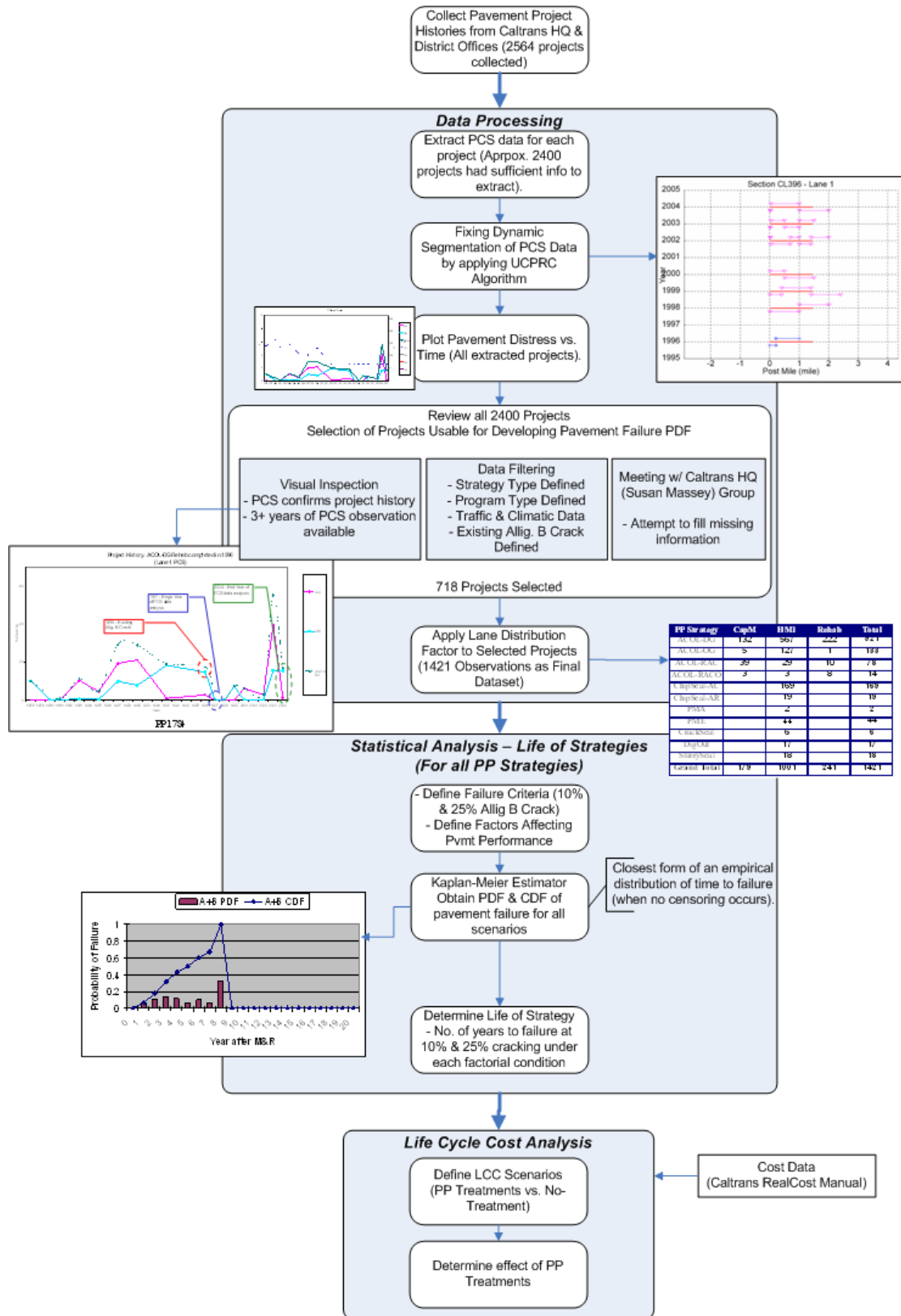

2 PROCESS FOR SELECTING USABLE DATA

This section describes how it was determined which specific sections of roadway performance information to retrieve. The algorithm and criteria created by UCPRC to overcome difficulties caused by the data structure of the current PCS database are presented to show how a particular section's performance is determined to be useful or not for the purposes of this study.

The Caltrans HQ and District staff members who provided project construction histories for the research are listed below. This project could not have been completed without their input.

District	Name	HQ	Name
2	Lance Brown	HQ Maint	Brian Toepfer
4	Robert Carmago	HQ Maint	Nerissa Chin
7	Gotson Okereke	HQ Maint	Susan Massey
8	Basem Muallem	HQ Maint	Rob Marsh
8	John Cai	HQ Maint	Leo Mahserelli
9	John Fox	HQ Maint	Brian Weber
10	Alvin Mangandin	HQ Maint	Ron Jones
10	Long Huynh	HQ Constr	Jim Cotey
11	Al Herrera	HQ DRI	Joe Holland
11	Dave Pound	HQ DRI	Alfredo Rodriguez

HQ Maintenance recommended those District offices where historical project information might be accessible. Ms. Kelly McClain in District 5 provided additional project histories after analysis of the database, so those projects are not included in these results but are available for future study.

The project flowchart (Figure 1) shows that key steps were to extract PCS data, apply the dynamic segmentation-weighting algorithm, plot PCS data for fixed segments of each project, and then visually inspect segments first to determine whether PCS agrees with project construction history and then to determine an analysis period based on reasonableness of PCS trends.

This study focused on cracking only. International Roughness Index (IRI) data were not used because previous studies by UCPRC found several problems with the database. (2, 3)

- There was little or no IRI data between 1992 and 1997.
- There were equipment calibration problems around 2000.
- Most of the sites had a sudden drop in IRI in 2003.
- IRI shows a decreasing trend in many cases where no record of pavement maintenance could be found.
- IRI in certain cases is very low (<60) even where there was no evidence of treatment.

Rutting was not included because it has been surveyed as a binary variable (0 if not present, 1 if present) and did not show consistency from year to year. Similarly, transverse cracking collection practice changed during the survey and was not consistent when data from successive years was plotted as a time history.

2.1 Dynamic Segmentation

During extraction of the PCS data, UCPRC applied an algorithm it had developed to adjust for the dynamic segmentation used in the PCS (3).

Figure 2 shows an example of differences between project limits and PCS dynamic segments. The data are from the truck lane on I-505, southbound, PM 1.45 to 0.00, at the Yolo–Solano county line. The thick line shown without symbols indicates limits of the construction project being tracked through time. Triangles indicate the limits of the segments in the PCS database in each year, using the dynamic segmentation approach used by the PMS in the years included in the study. A + symbol indicates that the PCS rater observed a different pavement surface in 1996 than in 1998 and afterward. Reasons for gaps in between the rated segments are unknown.

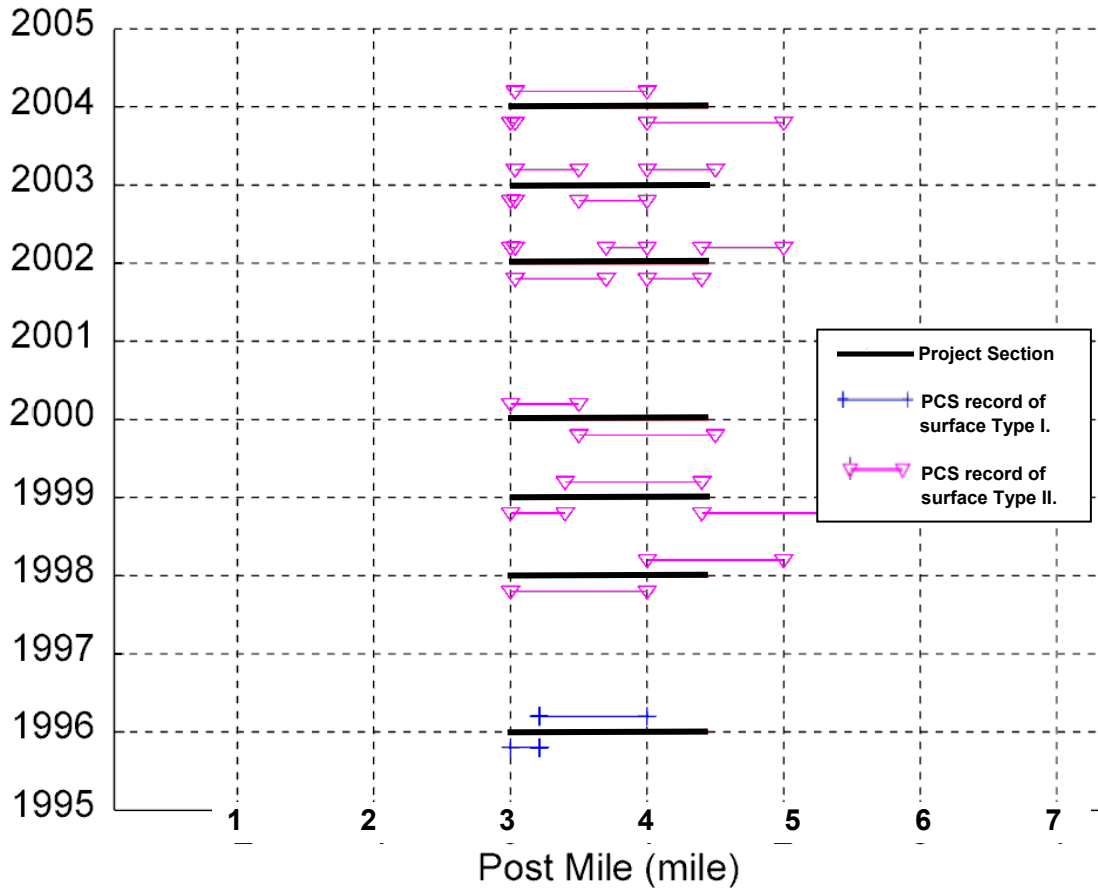

Figure 2: Example of dynamic segmentation versus project limits.

Caltrans PCS pavement segments in a given year usually do not have exactly the same beginning and ending post miles as the UCPRC-selected segments that are held consistent through the full time period. During PCS data extraction, Caltrans PCS data segments were included in the calculation of the percentage of the wheelpath that cracked if they fell within the four scenarios described below. The terms used in these scenarios are:

- PMSEND = End Post Mile of Caltrans PCS segment
- PMSBEG = Start Post Mile of Caltrans PCS segment
- CLBEG = Start Post Mile of construction project segment (called UCPRC segment)
- CLEND = End Post Mile of construction project segment (called UCPRC segment)

The four scenarios are defined below and presented graphically in Figure 3 through Figure 6.

Scenario 1: The Caltrans PCS segment starts outside the UCPRC segment but ends within the UCPRC segment, with the condition that the overlapping length is greater than 10 percent of the UCPRC segment, i.e., $(PMSSEND-CLBEG) \geq 0.1*(CLEND-CLBEG)$. The overlap condition was applied based on engineering judgment, and is based on the fact that Caltrans PCS procedures call for walking evaluation of the first 100 ft of each Caltrans PCS segment with the assumption that the rest of the Caltrans PCS segment is similar to the first 100 ft. Greater than 10 percent overlap was desired as a minimum so that the condition of the first 100 ft of the Caltrans PCS segment is similar to the UCPRC segment condition.

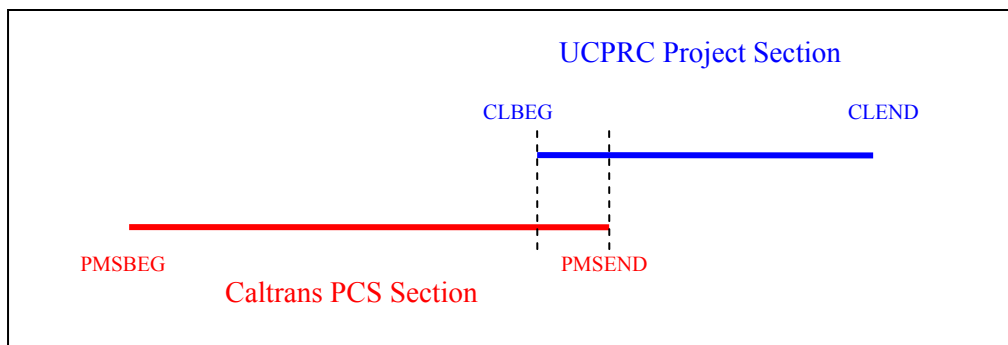

Figure 3: Scenario 1.

Scenario 2: The Caltrans segment starts within the UCPRC segment, i.e., $PMSBEG \geq CLBEG$. The 10 percent overlap requirement was not applied to this scenario because it was assumed that since the 100 ft of the Caltrans PCS segment actually surveyed by walking is within the UCPRC segment, they should be similar.

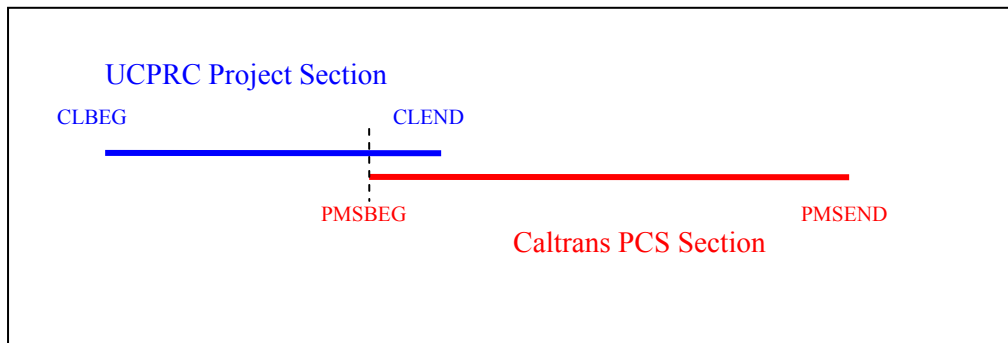

Figure 4: Scenario 2.

Scenario 3: The Caltrans segment covers the entire length of the UCPRC project segment, i.e., $(PMSBEG \leq CLBEG)$ AND $(PMSSEND \geq CLEND)$.

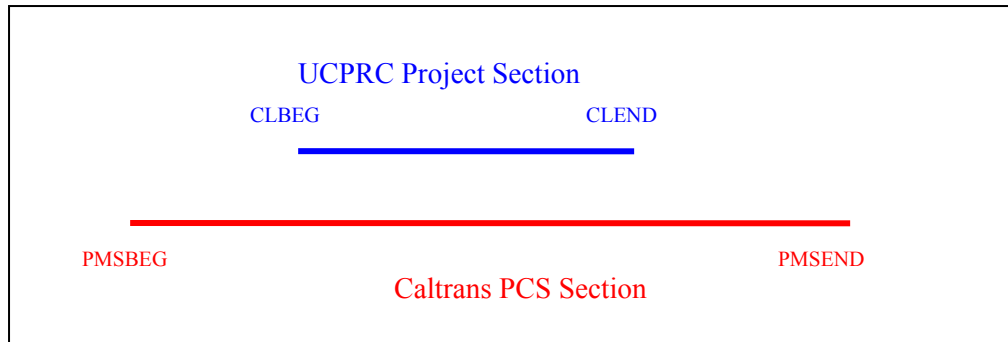

Figure 5: Scenario 3.

Scenario 4: The Caltrans segment lies within the boundaries of the UCPRC project segment, i.e., $(PMSBEG \geq CLBEG)$ AND $(PMSSEND \leq CLEND)$.

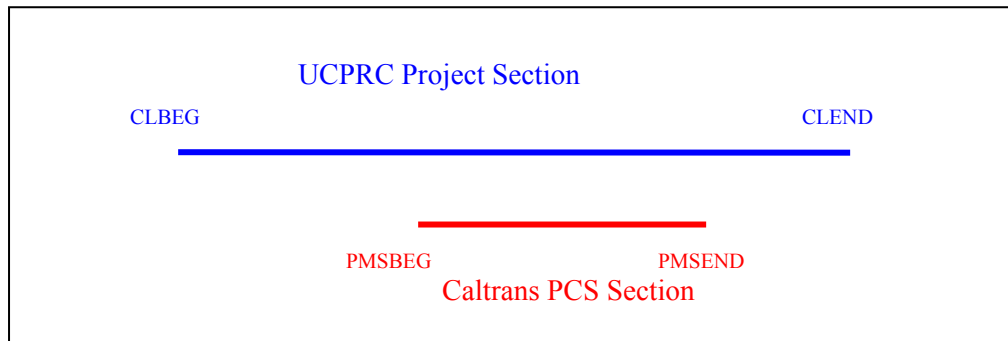

Figure 6: Scenario 4.

To associate the extracted PCS data with the construction project limits for the maintenance treatment, data extraction and weighting was performed as described below.

1. *Data Extraction Algorithm:* Data was extracted from three Caltrans PCS databases (1978 to 1992, 1994 to 1997, and 1998 to 2004). For a given project, a query was set to include all PCS segments in the database of segments to be used for further analysis that match any of the four cases described above.
2. *Weighting Algorithm:* An algorithm for calculating a *weighted average* pavement distress extent for a UCPRC project segment using the condition survey data for the Caltrans PCS segments in each year was applied to the following distresses: Alligator A (AAC) cracks (percent of wheelpath), Alligator B (ABC) cracks (percent of wheelpath) for segments selected for further

analysis using the Data Extraction Algorithm in Step 1. The formula used to calculate the weighted averages was:

$$\text{Weighted Average \% wheelpath cracked} = \left(\sum_i^n (\text{distress}_i * \text{CTsegmi_length}) / \left(\sum_i^n \text{CTsegmi_length} \right) \right) \quad (1)$$

where:

distress_i = measured value of AAC or ABC for a Caltrans PCS segment that falls into one of the four dynamic segmentation scenarios above;

CTsegmi_length = the length of the Caltrans PCS segment whose distress was reported as part of the UCPRC segment and whose measured extent of cracking is included in calculation of UCPRC segment cracking extent;

n = sequence number of the Caltrans segments crossing UCPRC project segment boundaries.

An example of the weighted average percent wheelpath cracked calculation is shown below, where three Caltrans PCS segments are identified as being applicable to the UCPRC segment (based on Scenarios 1, 4, and 2, respectively from left to right).

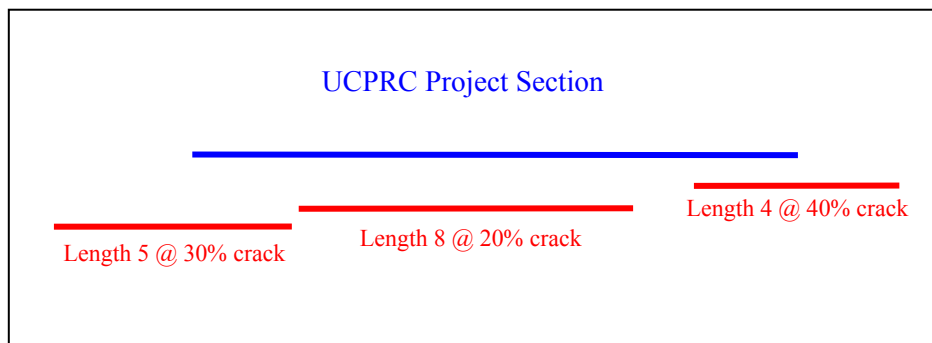

The weighted average for the example shown above is:

$$\text{Weighted Average \% wheelpath cracked} = \frac{(30 \times 5) + (20 \times 8) + (40 \times 4)}{5 + 8 + 4} = 27.65$$

2.2 Project Selection

After preparing weighted distress extent for cracking for each segment in each year of the PCS database, the data were reviewed, compared with available project construction histories, and selected for further analysis if the construction history matched the cracking time history. Sections were selected for further analysis using the criteria shown below.

- Use the segment if cracking drops close to zero within a year before or two years after the identified construction date. The purpose of this grace period is that we have only the approximate date of the start of the construction contract, not the date the construction was

actually performed. This criterion is expected to result in conservative estimates of number of years to predefined cracking levels.

- Check whether duplicate condition survey records are found for the segment, and eliminate one segment record if duplicated.
- Do not use segment if significant improvement is noted in pavement condition but no records of construction.
- Do not use segment if two years of condition survey data or less are available after a construction project date.

An example of how these criteria were applied to project information to determine whether they should be further analyzed is provided below. The example draws on information from a rehabilitation project involving placement of a dense-graded asphalt concrete overlay (ACOL-DG) completed in 1996 on 4-SM-84-PM20-21.5 in Lane 1. Figure 7 contains PCS data from 1978 through 2004. The condition and project history are characterized as follows for this study.

- Construction records show completion in 1996. Records do not indicate whether this is the date of closeout of the contract or closing of the Caltrans Expenditure Authorization (EA). The date is assumed not to be the construction completion date.
- The estimated rehabilitation construction date of between 1996 and 1997 correlates with Alligator B cracking time history from the condition survey data, which shows that 15 percent of the wheelpath cracked in 1996 and zero cracking occurred in the wheelpath in 1997. For some projects, the beginning year was assumed even if cracking occurred after the assumed construction year of up to 5 percent of the wheelpath, to account for sources of error, e.g., errors made during condition rating or rounding errors made when using the data extraction algorithm and the condition survey-averaging algorithm.
- The portion of the total PCS history used for this project is from 1997 to 2004, i.e., the estimated date of construction of the overlay to the last year available in the PCS database.

**Project History: ACOL-DG Rehab completed in 1996
(Lane 1 PCS)**

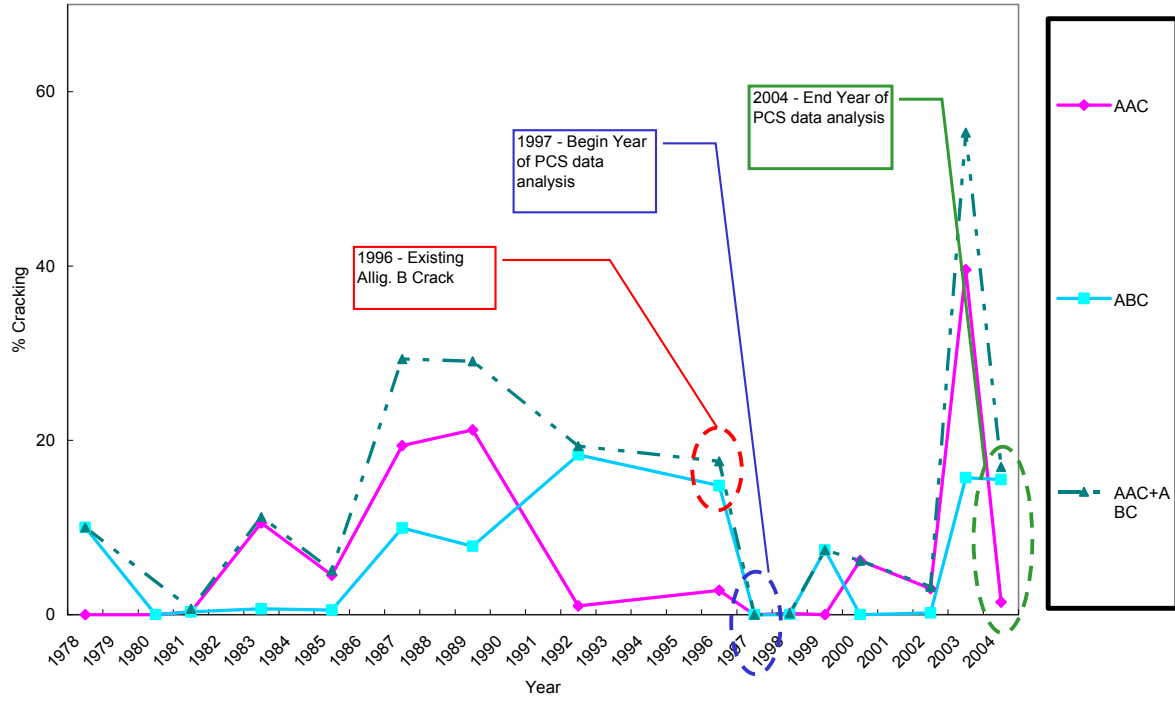

Figure 7: Example of project selection process (4-SM-84-PM20-PM21.5).
 (Note: AAC is Alligator A cracking as percentage of the wheelpaths cracked; ABC is Alligator B cracking; AAC+ABC is the combined cracking.)

3 SUMMARY OF DATABASE

This chapter describes how the size of the project database evolved from the study's start to the smaller sample database used for the performance analyses as the selection criteria described in Section 2 were applied. This chapter describes further adjustments to the database and summarizes the projects in the final database.

3.1 Initial Database of Projects

The UCPRC collected construction histories for 2,564 projects. A total of 1,846 projects were eliminated for the reasons shown in Table 2. These reductions resulted in a database of 718 pavement preservation (PP) projects identified as having adequate PCS histories for performance evaluation.

Table 2: List of Deleted Project Histories

Number of Projects	Reason for Deletion
941	Project started in 2003 or later, so insufficient performance history data.
567	Performance history does not match construction history.
178	Duplicate construction project entries.
160	No project completion date.

An additional 25 rehabilitation (control) projects and rehabilitation with pavement preservation treatment projects from District 9 were investigated beyond the 718 projects. Unfortunately, most of these sections either did not show distress at the time of final data collection or they had insufficient information necessary to draw conclusions. They were not considered further in this investigation.

The remaining 718 projects were sorted by strategy (ACOL, chip seal, slurry, etc.) and program category (CapM, HM-1, Rehab). Table 3 shows the distribution of the selected projects based on their strategy and funding program. The funding program was needed to approximately identify asphalt overlay thicknesses, since no other thickness information was available. The funding program was also needed to compare the practice for placing the overlays, in terms of extent of distress, with the intention of the funding program, either maintenance or rehabilitation. The project information did not consistently specify direction and lanes treated. No layer thickness data for ACOL were available.

Table 3: Project Distribution—One Observation per Selected Project

PP Strategy	CapM	HM-1	Rehab	(unknown)	Total
ACOL-DG	31	275	36	79	421
ACOL-OG	–	51	–	18	69
ACOL-RAC	–	8	–	9	17
ACOL-RACO	–	2	–	2	4
ChipSeal-AC	–	79	–	–	79
ChipSeal-AR	–	6	–	5	11
ChipSeal-PMA	–	1	–	–	1
ChipSeal-PME	–	7	–	17	24
CrackSeal	–	2	–	1	3
DigOut	–	10	–	–	10
SlurrySeal	–	6	–	2	8
(blank)	3	14	–	54	71
Total	34	461	36	187	718

Note: 127 of the 718 data points are composite sections (approximately 18 percent). Projects were identified as composite if any PCC distress was noted in PMS (from 1978).

It should be noted that a large majority of the asphalt overlays come from the HM-1 and CAPM programs, which have strict limits on the thickness of overlay that can be applied. For this reason, it was decided that the lack of overlay thickness data in the Caltrans records did not prevent preliminary estimates of performance from being made. It should also be noted that “digout,” shown in Table 3 and elsewhere in this technical memorandum, is not a pavement preservation treatment, but instead a repair performed on a distressed pavement. It consists of milling out a portion of the thickness of cracked asphalt concrete in the wheelpaths and inlaying it with asphalt concrete. Sometimes digouts are performed prior to placement of an overlay, and sometimes they are done without accompanying work. The construction project data available in the PMS and in personal databases kept by District and HQ staff were often not clear as to what was done with the digouts. Identification of the work performed is not standardized or based on codes, and is often included only as a comment in the “Notes” part of the PMS database.

3.2 Database of Observations

3.2.1 Adjusting for Traffic

The 718 projects include multiple lanes and two directions. By applying lane distribution factors to each lane of each project, more observations (each lane having different performance linked to different traffic) were made available for developing failure probabilities. Lane distribution information for Annual Average Daily Truck Traffic (AADTT) was applied from Lu et al. (4). Lane distribution factors are shown in Table 4, and it was assumed that these factors applied to all projects.

Table 4: Average Lane Distribution Factor of AADTT for Highway with Different Number of Lanes in One Direction (4)

Number of Lanes in One Direction	Lane 1	Lane 2	Lane 3	Lane 4	Lane 5	Lane 6
1	1.00	0.00	0.00	0.00	0.00	0.00
2	0.09	0.91	0.00	0.00	0.00	0.00
3	0.06	0.33	0.67	0.00	0.00	0.00
4	0.05	0.09	0.44	0.49	0.00	0.00
5	0.00	0.05	0.27	0.58	0.25	0.00
6	0.00	0.00	0.00	0.16	0.50	0.34

Applying the lane distribution factors to those projects with multiple lanes produced a total of 1,508 observations from the 718 projects, as shown in Table 5.

Table 5: Distribution of Observations (Considering Multiple Lanes and Both Directions)

PP Strategy	CapM	HM-1	Rehab	Total
ACOL-DG	136	600	250	986
ACOL-OG	5	131	1	137
ACOL-RAC	39	29	10	78
ACOL-RACO	3	3	8	14
ChipSeal-AC	–	181	–	181
ChipSeal-AR	–	21	–	21
ChipSeal-PMA	–	2	–	2
ChipSeal-PME	–	46	–	46
CrackSeal	–	6	–	6
DigOut	–	17	–	17
SlurrySeal	–	20	–	20
Total	183	1,056	269	1,508

3.2.2 Adjusting for Missing Lane Prior Condition Data

Inner lanes are not surveyed every year, and projects lacking PCS data were deleted from the database. PCS data prior to treatment were required to evaluate the effect of existing cracking on the performance of treatments. Due to the fact that PCS data were not recorded every year, PCS data was sought that had existing cracking within a few years before construction. By evaluating distress data three to five years before the treatment (with at least one PCS data point in that period), it was possible to obtain the number of observations shown in Table 6.

Table 6: Number of Observations with Missing PCS Data

Tracked Number of Years	Number of Observations Deleted	Number of Observations Remaining
3 years prior	90 (6.0 percent)	1,418
4 years prior	42 (2.8 percent)	1,466
5 years prior	33 (2.2 percent)	1,475

It was decided to use four years as a limit after consideration of three, four, and five years. If three years were used, the number of observations would have been approximately halved (reduced from 6% to 2.8%) and a five-year limit would only have reduced the deleted observations by another 0.6%. This produced a revised distribution as shown in Table 7.

Table 7: Distribution of Observations After Adjusting for Missing Prior Condition Data

PP Strategy	CapM	HM-1	Rehab	Total
ACOL-DG	136	583	235	954
ACOL-OG	5	127	1	133
ACOL-RAC	39	29	10	78
ACOL-RACO	3	3	8	14
ChipSeal-AC	–	175	–	175
ChipSeal-AR	–	21	–	21
ChipSeal-PMA	–	2	–	2
ChipSeal-PME	–	46	–	46
CrackSeal	–	6	–	6
DigOut	–	17	–	17
SlurrySeal	–	20	–	20
Total	183	1,029	254	1,466

Further adjustment was needed for observations (lanes within projects) that have no traffic data (AADTT) available. This resulted in a database containing 1,421 unique segments consisting of a single lane with a construction history, a condition survey history both before and after construction, and truck traffic data that was to be used for developing failure probabilities. Projects included in the database and used for further analysis span an actual period from 1988 to 2003, so they reflect the practices, policies, and procedures (within HQ and the Districts) during that time. The final database is summarized in Table 8.

Table 8: Distribution of Observations for Final Set of Data Used for Failure Probability Analysis

PP Strategy	CapM	HM-1	Rehab	Total
ACOL-DG	132	567	222	921
ACOL-OG	5	127	1	133
ACOL-RAC	39	29	10	78
ACOL-RACO	3	3	8	14
ChipSeal-AC		169		169
ChipSeal-AR		19		19
ChipSeal-PMA		2		2
ChipSeal-PME		44		44
CrackSeal		6		6
DigOut		17		17
SlurrySeal		18		18
Total	179	1,001	241	1,421

A higher proportion of the composite sections (asphalt overlays on PCC pavement) were rehabilitation sections as opposed to maintenance sections than is seen in the full data set, as shown in Table 9.

Table 9: Distribution of Observations for Composite Sections

Action Category	CAPM	HM-1	REHAB	Total
ACOL-DG	26	14	53	93
ACOL-OG	0*	9	0	9
ACOL-RAC	3	4	0	7
ACOL-RACO	0	2	8	10
ChipSeal-AC	–	4	–	4
ChipSeal-AR	–	0	–	0
ChipSeal-PMA	–	0	–	0
ChipSeal-PME	–	8	–	8
CrackSeal	–	2	–	2
DigOut	–	0	–	0
SlurrySeal	–	8	–	8
Total	29	51	61	141

* Zero values indicate that there were observations for this program/strategy but none was composite.

It will be observed that many of the strategies have a small number of observations on which to base conclusions. Note also that while composite pavements comprised 127 of the 718 projects in the database, only 141 (10 percent) of the 1,421 observations were composite sections.

3.2.3 Distribution of Projects and Observations by District

Table 10 shows the distribution of observations (unique lanes with complete data) by program type and District in the dataset. It shows that:

- Over half of the HM-1 projects in the database are in District 2, and nearly a quarter are in District 8.
- CapM projects are distributed evenly between Districts 2 and 4.
- The majority of rehabilitation projects are in urban districts, including Districts 4, 7, and 8.

Table 10: Distribution of Observations by Program Type and District

Program Type	District												Grand Total
	1	2	3	4	5	6	7	8	9	10	11	12	
CAPM		72		71	1		16	19					179
HMI	26	554	2	74	19	46	11	227	11	18	10	3	1001
REHAB		67	1	29			101	39	4				241
Grand Total	26	693	3	174	20	46	128	285	15	18	10	3	1421

The distribution of PP strategies that could be obtained by district is presented below. Table 11 shows that:

- For conventional AC overlays (ACOL-DG), over half are in District 2 and nearly half are in Districts 4, 7, and 8.
- For rubberized overlays (ACOL-RAC), nearly all are in Districts 4, 7, and 8.
- For conventional chip seals, nearly three-quarters are in District 2.
- Other strategies have small sample sizes.

Table 11: Distribution of Observations by Strategy and District

PP Strategy	District												Total by Strategy
	1	2	3	4	5	6	7	8	9	10	11	12	
ACOL-DG	2	513		94	7	22	100	167	6	7		3	921
ACOL-OG	20	9	3	33	6	6	2	49	3	2			133
ACOL-RAC		4		32			26	16					78
ACOL-RACO				9				5					14
ChipSeal-AC		129		2				38					169
ChipSeal-AR				2	5			10			2		19
ChipSeal-PMA				2									2
ChipSeal-PME	4	7			2	18			4	1	8		44
CrackSeal									2	4			6
DigOut		17											17
SlurrySeal		14								4			18
Total by District	26	693	3	174	20	46	128	285	15	18	10	3	1421
Percent by District	2%	49%	0%	12%	1%	3%	9%	20%	1%	1%	1%	0%	100%

The database is a cross section of conditions statewide. For example, District 2 represents northern California, with four climate regions and a combination of low-volume routes and high-volume Interstate-5. In contrast, District 8 provides data from a dry/desert climate in southern California with both urban and rural routes. District 4 provides data for urban and rural routes in a coastal environment.

To check the consistency in the composition of the original set of projects with the final database across districts, the original database of 2,564 projects is compared to the selected 718 projects and to the final data set of the 1,421 observations as shown in Table 12, which shows that:

- Other than District 2, the proportion of projects is fairly consistent for each of the data sets.
- Projects in District 2 became a higher percentage of observations during the screening process because of the good agreement between project histories and PCS data.

Table 12: Distribution of Projects and Observations by Districts

	District												Total
	1	2	3	4	5	6	7	8	9	10	11	12	
Original 2564 Projects	3%	24%	3%	18%	5%	8%	7%	19%	4%	5%	2%	2%	100%
718 Projects	2%	44%	0%	15%	1%	3%	7%	23%	2%	1%	1%	1%	100%
1421 Observations	2%	49%	0%	12%	1%	3%	9%	20%	1%	1%	1%	0%	100%

4 SUMMARY OF PRACTICE 1988 TO 2003

This section summarizes the pavement preservation treatments used by Caltrans in the period of 1988 to 2003 and the timing of their application with respect to extent of cracking. The summary is based on data collected and selected by the process described in the preceding sections.

From the adjusted database of observations, average (mean) existing distress levels before treatment were determined for each pavement preservation (PP) strategy. The results are presented in Table 13.

Table 13: Mean Existing Cracking Levels When Each PP Strategy Performed

PP Strategy	A+B Crack (%)		A Crack (%)	B Crack (%)
	Mean	Std. Dev.	Mean	Mean
ACOL-DG	26	24	10	16
ACOL-OG	25	20	10	15
ACOL-RAC	32	30	12	20
ACOL-RACO	3	5	1	1
ChipSeal-AC	17	18	8	10
ChipSeal-AR	18	15	5	13
ChipSeal-PMA	21	3	6	15
ChipSeal-PME	11	11	5	6
CrackSeal	28	22	9	19
DigOut	48	28	13	36
SlurrySeal	2	3	2	1

Existing cracking levels sorted by PP strategy as well as funding program category (CapM, HM-1, and Rehabilitation) are presented in Table 14. The information shown in Table 13 and Table 14 indicates the following:

- For rehabilitation using ACOL-DG, the database of observations shows a mean value of existing Alligator B cracking (16 percent) that is below the PMS prioritization table trigger value of 25 percent. Actual overlay thickness is not known, and it is unknown what other activities were done on these projects in conjunction with the overlays that might affect performance.
- In general, HM-1 program activities appear likely to be performed at higher existing cracking than these strategies are intended, and at cracking levels that are similar to those of rehabilitation projects. Drawing further inferences from this observation should be done cautiously because of limitations and uncertainties in the database, such as the use of PCS data acquired as long as three years before the placement of treatments.

- Despite differences in the sizes of samples for various strategies and programs, treatment strategies show relatively consistent levels of existing cracking (A, B, and A+B) when the strategy was applied. Older Caltrans priority assignments for rehabilitation or maintenance treatment (from the period applicable to this memorandum) indicate various identifiers for “unacceptable” conditions with respect to cracking of 30 percent Alligator B cracking, or 10 percent Alligator B cracking combined with more than 10 percent patching, or no Alligator B cracking combined with more than 15 percent patching. Patching is presumed to indicate repaired alligator cracking. One outlier in this pattern is existing cracking ACOI-RAC rehabilitation, which appears to be applied at higher levels of cracking than ACOI-DG. Again, caution should be noted with regard to this inference because of the small sample of projects (10).
- For digouts and crack sealing, existing cracking levels are near or well above the 25 percent Alligator B cracking trigger used for rehabilitation.

These results, in particular the thin overlays and chip seals placed through the HM-1 program, indicate that Caltrans maintenance practice during the period of 1988 to 2003 is not what is considered pavement preservation because of the high levels of cracking present at the time of treatment. The results also suggest that many overlays will fail due to reflection cracking, since cracks have already appeared at the pavement surface at the time of overlay. Although well-calibrated mechanistic models of reflection cracking are only now being developed, most studies in the literature indicate that overlays placed over pavement with surface cracks will have shorter lives than pavements without surface cracking, because cracks result in larger strains at the bottom of the overlay due to strain concentration.

Table 14: Existing Cracking Data for Each PP Strategy and Program

PP Strategy	Existing Cracking Type	Program Type						POOLED DATA	
		CAPM		HM-1		REHAB		Mean	Std. Dev.
		Mean	Std. Dev.	Mean	Std. Dev.	Mean	Std. Dev.		
ACOL-DG	Alligator A	9	13	10	11	9	11	10	11
	Alligator B	12	14	17	18	16	20	16	18
	Alligator A+B	21	22	27	24	25	26	26	24
ACOL-OG	Alligator A	12	7	10	11	8		10	11
	Alligator B	16	8	14	16	19		15	15
	Alligator A+B	28	15	25	21	27		25	20
ACOL-RAC	Alligator A	10	12	9	11	26	12	12	13
	Alligator B	13	16	21	19	45	29	20	21
	Alligator A+B	23	25	30	24	71	34	32	30
ACOL-RACO	Alligator A	3	2	4	6	0		1	3
	Alligator B	4	6	2	1	0		1	3
	Alligator A+B	7	7	6	7	0		3	5
ChipSeal-AC	Alligator A			8	10			8	10
	Alligator B			10	12			10	12
	Alligator A+B			17	18			17	18
ChipSeal-AR	Alligator A			5	4			5	4
	Alligator B			13	13			13	13
	Alligator A+B			18	15			18	15
ChipSeal-PMA	Alligator A			6	1			6	1
	Alligator B			15	5			15	5
	Alligator A+B			21	3			21	3
ChipSeal-PME	Alligator A			5	5			5	5
	Alligator B			6	8			6	8
	Alligator A+B			11	11			11	11
CrackSeal	Alligator A			9	7			9	7
	Alligator B			19	15			19	15
	Alligator A+B			28	22			28	22
DigOut	Alligator A			13	15			13	15
	Alligator B			36	22			36	22
	Alligator A+B			48	28			48	28
SlurrySeal	Alligator A			2	3			2	3
	Alligator B			1	1			1	1
	Alligator A+B			2	3			2	3

5 FACTORS INFLUENCING PERFORMANCE

This chapter describes statistical analysis that helped determine the factors (both traffic and environmental) that correlate with the cracking performance of the pavement preservation strategies. Based on a UCPRC study of cracking initiation and progression models using the Washington State Department of Transportation (WSDOT) database [6], temperature, precipitation, and AADTT/lane are factors found to be important in future pavement performance. Existing Alligator B cracking (ExABC) is also used as one of the main factors affecting pavement performance, for two reasons. First, existing cracking condition was found to be one of the significant factors in the WSDOT study. Second, Caltrans uses Alligator B cracking as a trigger for maintenance and rehabilitation.

5.1 Check Correlation of Factors

If two explanatory factors are highly correlated with each other (with correlation value close to 1 or -1), that means the effect of one factor can probably be demonstrated by the presence of another factor, which reduces the significance of the original factor itself. In this event, a transformation process to combine the two factors into a new third factor is usually performed to try to capture the effect of the original two factors by just this newly created one. Table 15 presents a correlation table for five factors (developed using an Microsoft *Excel*TM function) affecting pavement performance and their correlation value against all other factors. It can be seen in the table that these factors are not highly correlated with each other. Therefore, a transformation to combine any two or more factors is not necessary. The exceptions are the annual number of freeze-thaw cycles and the minimum temperature, which are highly correlated with the number of freeze-thaw cycles expected to increase in colder regions. Therefore only one of these two variables can be used or they must be combined. Based on this comparison and on previous findings from UCPRC work (5), minimum annual temperature was selected for use because it was previously found to be a more significant factor in predicting cracking initiation.

Min Temp:	Average minimum annual temperature in degrees Celsius (°C)
Precip:	Average annual precipitation (mm)
Ftavg:	Average annual number of freeze-thaw cycles
exABC:	Existing Alligator B cracking prior to treatment
AADTT:	Average annual daily truck traffic

Table 15: Correlation Table—Factors Affecting Pavement Performance

	Min Temp	Precip	Ftavg	exABC	AADTT
Min Temp	1				
Precip	-0.05936	1			
Ftavg	-0.96333	0.146822	1		
exABC	0.021578	-0.11972	-0.0122	1	
AADTT	0.224235	-0.16123	0.25772	0.10635	1

5.2 Analysis of Factors

Table 16 presents the range, median, and mean values of the minimum annual temperature (MinTemp), average annual precipitation (Precip), and AADTT/lane (AADTT). The table also shows the distribution of observations within each range of the existing cracking (exABC).

Shown below are “factors” affecting performance and descriptive statistics for project locations. Factors in the analysis are defined from the variables described in Section 5.1 as follows, based on their median values:

MinTemp was divided into two categories:

- cold = minimum annual air temperature less than or equal to -7.6°C, and
- hot = minimum annual air temperature greater than -7.6°C.

Precip was divided into two categories:

- dry = annual precipitation less than or equal to 464 mm/year, and
- wet = annual precipitation greater than 464 mm/year.

AADTT was divided into three categories:

- low traffic = less than or equal to 125 AADTT/lane, and
- high traffic = greater than 125 AADTT/lane

exABC was divided into three categories

- existing Alligator B cracking = less than or equal to 10%; more than 10% and less than or equal to 25%; more than 25%

The sample size for existing cracking in the three categories is shown in Table 16.

Table 16: Descriptive Statistics of Factors Affecting Cracking Performance in Data

Descriptive Statistic for Climate and Traffic Factors	Min. Temperature (°C/ °F)	Annual Precipitation (mm / inches)	AADTT/Lane
Min	-26.3 / -15.3	0 / 0	0
Max	4.6 / 40.3	1,977 / 77.8	6,567
Median	-7.6 / 18.3	464 / 18.3	125
Average	-9.4 / 15.1	594 / 23.4	355
Distribution of Alligator B Cracking Extents			
Existing Alligator B Crack	≤ 10%	10% < x ≤ 25%	> 25%
Sample Size	743	361	317

Analysis to determine which factors are significant was based on data for the ACOL-DG strategy in the HM-1 program category because this data set had the highest number of observations, and overlay thicknesses are nearly always less than 60 mm (0.2 ft), thus ensuring that there was not a wide range of overlay thicknesses in the data set. The Cox Survival model (a regression method that does not try to fit a fixed mathematical form) was used to obtain the Z-statistic and p-value for determining the significance of each factor independently for: minimum annual temperature (MinTemp), annual precipitation (Precip), existing Alligator B cracking (exABC), and traffic (AADTT). A p-value of 0.10 or less is typically regarded as indicating that an explanatory variable is significant, while a p-value of 0.05 indicates that an explanatory variable is highly significant.

Table 17: Statistics of Factors Affecting Pavement Performance in Data

Variable	Std. Error	Z	p-value P> z	95% Conf. Interval	
MinTemp	0.1576932	0.38	0.703	0.7904394	1.417407
Precip	0.2038066	2.59	0.01	1.092777	1.901946
exABC	0.1056617	2.45	0.014	1.043213	1.459346
AADTT	0.1639774	1.32	0.186	0.9163076	1.566823

Table 17 shows that when the four factors are grouped to check for statistical significance, only “Precip” and “exABC” are significant at a 95 percent confidence level (based on P>|z| values), meaning that the p-value is less than 0.05. The least significant variable, “MinTemp,” was removed and the remaining three factors were tested again to see if their significance increased.

Table 18: Statistics of Factors Affecting Pavement Performance in Data without MinTemp

Variable	Std. Error	Z	p-value P> z	95% Conf. Interval	
Precip	0.2016425	2.56	0.01	1.088609	1.889077
exABC	0.1051345	2.43	0.015	1.041001	1.455048
AADTT	0.1602786	1.47	0.14	0.9379399	1.573247

Based on the $P>|z|$ values in Table 18, “AADTT” continued to not be statistically significant even after removing “MinTemp.” This is believed to be due to an insufficient dataset that is unable to capture the significance of the effect of traffic load to pavement cracking. It may also be necessary to split AADTT using some value other than the median to increase its significance. Based on widely accepted previous findings and engineering judgment on the significance of traffic loading to pavement performance, it is important to keep traffic as an explanatory variable despite the low p-value.

Results from this analysis can be compared with previous studies regarding the effects of temperature. The life of thin dense-graded overlays with respect to fatigue cracking increases as the minimum annual temperature increases, according to the cracking initiation model that UCPRC developed using WSDOT data.

Statistical tests (t-test) also indicated that low temperatures have a greater impact on the initiation of cracking than do maximum temperatures, as shown in Table 19. (5)

Table 19: Significance Level of Temperature Factor in Pavement Performance

Variable	Coefficient	t-statistic
Tmax*	-5.63E-02	-1.21E+01
Tmin**	-1.88E-01	-2.43E+01

* Tmax: Average monthly maximum temperature of the hottest month (July, in °C).

** Tmin: Average monthly minimum temperature of the coldest month (December, in °C).

With regard to crack propagation, a UCPRC study based on WSDOT data also found that climate variables, particularly yearly precipitation and minimum temperature, play a significant role: the higher the yearly precipitation, the higher the rate of crack progression. Higher minimum temperatures reduce the rate of crack progression (6). The reason for the apparent lack of correlation between temperature and cracking performance in the database assembled for this study is not known.

Based on this analysis, the factors used for classifying the Alligator cracking performance of pavement preservation strategies in the current study are: existing Alligator B cracking, annual precipitation (dry/wet), and traffic (high/low).

6 PAVEMENT LIFE RESULTS

This chapter first describes the process followed and the assumptions made to derive the life of pavement treatments. It then presents the projected pavement life for the studied sections based on the statistical analysis and general observations. At the end of the section, the cost of each type of pavement treatment is presented to demonstrate how Caltrans can select the most cost-effective choice based on life-cycle cost rather than only on expected pavement service life.

6.1 Procedures Used to Develop Probability of Failure

Knowing the level of cracking in each of the years within the analysis period is required, to determine the likelihood of failure at specific points in time after construction. The following conditions were applied to the PCS condition survey data of each of the selected projects.

- Once the beginning and ending years are defined for the project life, it is expected that the cracking (sum of percentage of wheelpath with Alligator A and B cracking) will be non-decreasing during the analysis period.
- If cracking data are missing, an interpolated value is calculated between the year before and the year after the missing year.
- If the level of cracking drops in a year within the analysis period, then the cracking level from the previous year is used.

The probability density function (PDF) under the context of this study is the point estimate of the probability of reaching the threshold of pavement failure, e.g., 10 percent A+B Alligator cracking (combined percentage of wheelpath with Alligator A and B cracking), in a given year, which is designated as $\Pr(x=T)$.

x = time of interest (the particular year after treatment)

T = Time in year

The cumulative density function (CDF) is the probability of pavement failure at the predefined threshold since the completion of treatment, $\Pr(x<T)$.

The Kaplan-Meier estimator is used to estimate the failure probability of the pavement. It is the closest to a pure empirical estimator that can take “censored” data into account. An example of censored data in this study includes sections that lasted longer than the time period available in the PCS database. (A more detailed description of censored data is included in Appendix B: Definition of Data Censoring.) The Kaplan-Meier estimator is often used to measure the proportion of patients’ surviving for a certain amount of time after an operation, when a number of the patients have not yet died at the time of the study. That scenario is very similar to this study, which attempts to measure the life of a pavement after it has been treated.

The formula for computing the Kaplan-Meier estimate of the survivor function is:

$$\hat{S}(t) = \prod_{j=1}^k \left(\frac{n_j - d_j}{n_j} \right) \quad \text{For } t_{j-1} \leq t < t_j \quad (2)$$

where, n_j = number of pavements not failed and that are still being observed (termed “at risk”) before t_j and

d_j = number of pavements failed in the time interval $t_{j-1} \leq t < t_j$.

The failure probability of an item before t is then $\Pr(x < T) = 1 - \hat{S}(t)$.

An example is shown in Figure 8 for HM-1 ACOL-DG projects. (For details, see Appendix C: Example Calculation of Probability of Failure Distribution for Figure 8.) The Cumulative Distribution Function (CDF) for Alligator A cracking is indicated by the solid line. Each bar indicates the probability of failure for each year. In this example, all of the sections (n) in Year 9 failed (d), so the CDF reaches a value of 1.0 in that year. In this example, using the 50th percentile CDF as the expected pavement life means that half the projects will last seven years or less after construction, and the other half will last longer than seven years.

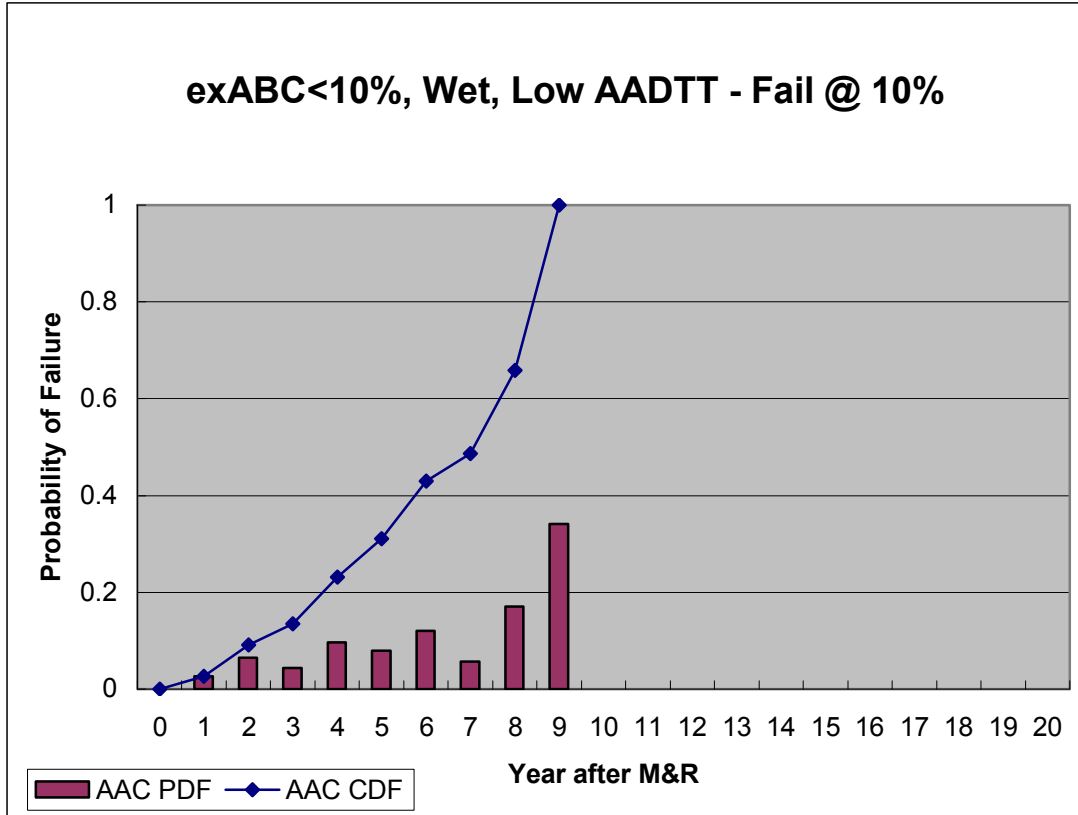

Figure 8: Example of probability distribution for HM-1 ACOL-DG for 10 percent Alligator A cracking.

A second example is presented to demonstrate the situation where the 50th percentile CDF is never reached in the scenario, shown in Figure 9. This is a scenario with ACOL-DG HM-1 treatment where the failure is defined as 25 percent Alligator A cracking. The highest CDF reached 45 percent by Year 12 but it never reached the median failure requirement of 50 percent, hence there was no median pavement life calculated for this particular treatment under this given set of conditions. Because there were sections that had not failed (n) in the years after Year 12, but there were no more observations in later years, the CDF stops in Year 12. The last CDF value for cases such as this represents the probability of failure in that year and beyond, for which there were no observations. For this example, the high value shown in Year 13 jumps to more than 60 percent because it includes the CDF of all years beyond Year 12. This indicates that more than 60 percent of the sections in the data set did not reach 25 percent Alligator A cracking by the end of the twelfth year.

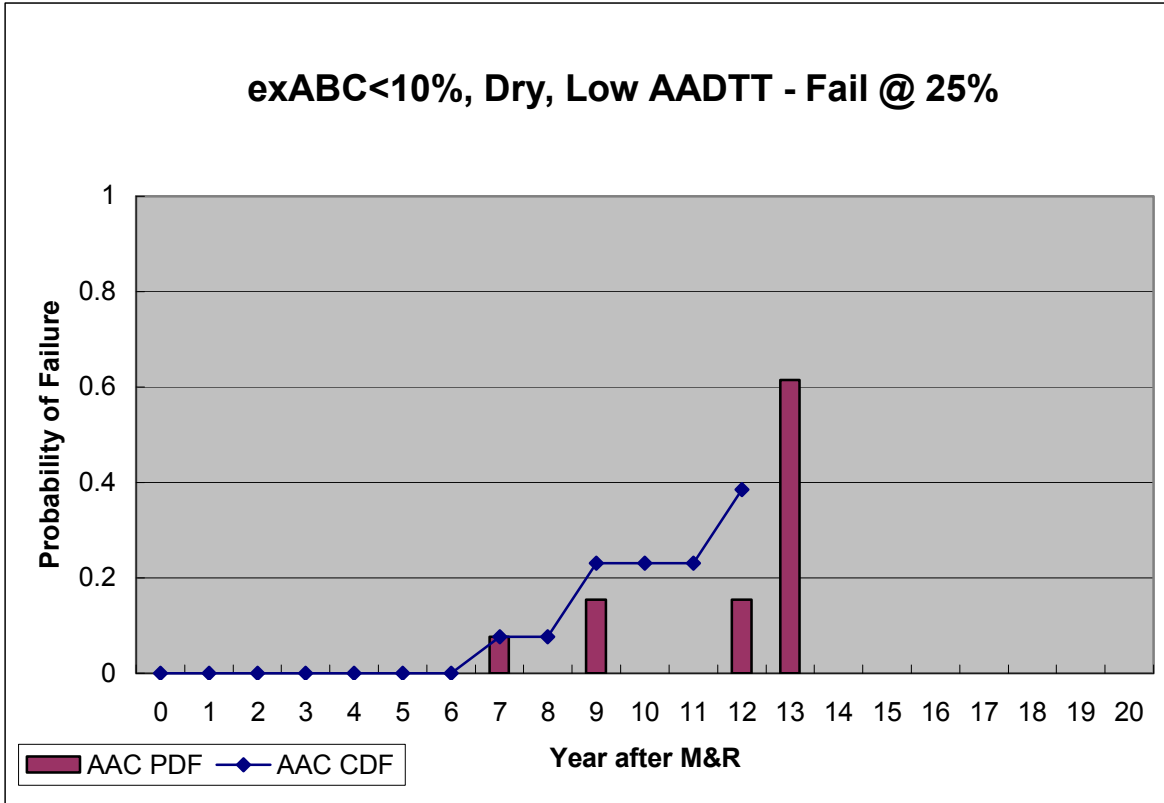

Figure 9: Example of probability distribution for HM-1 ACOL-DG.

6.2 Summary by Strategy and Program

Table 20 shows the pooled expected life (from the cumulative probability) for each type of PP strategy. Presented in the table is the expected life (number of years) to last until 10 percent and 25 percent cracking (B and A+B, where A+B is the percentage of Alligator A plus the percentage of Alligator B) after applying each strategy. Values shown are the 50th percentiles from the cumulative probability distributions. N/A indicates that the number of failures (reaching 10 percent or 25 percent cracking) did not reach 50 percent of the number of observations in the dataset for a given PP strategy. The following observations can be made from Table 20.

- Trends are reasonable and consistent. Expected life to 25 percent cracking is always longer than to 10 percent, and A+B always has a shorter life than B alone.
- For ACOL-DG, Rehabilitation projects last much longer than HM-1 projects.
- Chip seals provide four to six years of service before reaching 10 percent Alligator B.
- Slurry seals provide four years of service before 10 percent Alligator B.
- The time to increase from 10 percent to 25 percent Alligator B cracking is one to three years. This may have implications for programming pavement rehabilitation, where delays occur between the condition survey, programming, and actual construction.

Table 20: Expected Life for Each PP Strategy and Program Showing Years to Failure Levels, not Pre-Existing Cracking

PP Strategy		Sample Size	Alligator B Cracking		A+B Cracking	
			Years to 10%	Years to 25%	Years to 10%	Years to 25%
ACOL-DG	ALL	921	7	10	5	7
ACOL-DG	HM-1	567	5	8	4	6
ACOL-DG	REH	222	10	12	9	11
ACOL-DG	CAPM	132	*N/A	N/A	N/A	N/A
ACOL-OG	HM-1	127	6	N/A	6	6
ACOL-RAC	HM-1	29	10	N/A	8	N/A
ACOL-RACO	HM-1	3	N/A	N/A	4	N/A
ChipSeal-AC	HM-1	169	6	N/A	3	8
ChipSeal-AR	HM-1	19	4	5	3	4
ChipSeal-PMA	HM-1	2	N/A	N/A	1	N/A
ChipSeal-PME	HM-1	44	N/A	N/A	4	N/A
Crack Seal	HM-1	6	N/A	N/A	N/A	N/A
DigOut	HM-1	17	2	N/A	1	N/A
Slurry Seal	HM-1	18	4	6	3	4

* N/A indicates that the number of failures did not reach 50 percent of the number of observations within each strategy.

6.3 Summary of Factors Affecting Performance

Table 21 through Table 29 present the average (50th percentile) life expectancy for each type of pavement preservation strategy and program at the failure trigger levels. The tables show life expectancy for various levels of existing cracking, for wet or dry conditions, and for high or low traffic levels.

For ACOL-DG HM-1, the number of years to 10 percent Alligator B cracking is close to five years for all traffic and precipitation levels where existing Alligator B cracking is less than or equal to 25 percent.

The effect of traffic level on the number of years to 10 percent Alligator B cracking is reasonable, with high traffic resulting in one to two years of less service where existing Alligator B cracking is less than or equal to 25 percent.

Results for precipitation contradict what is expected: Wetter conditions are anticipated to result in shorter years of service life. This may be an artifact of using the median level of rainfall to produce comparably sized datasets for analysis. For existing cracking, the trend is reasonable: Increasing levels of cracking usually result in fewer years to reach the 10 percent and 25 percent cracking levels. These observations apply to Alligator A, B, and A+B cracking.

For chip seals (AC), where there is low existing Alligator B cracking (below 10 percent), chip seals last at least five years (until 10 percent Alligator B occurs). Increasing traffic can significantly reduce service life. There is no clear effect of precipitation in the presence of higher cracking (10 to 25 percent).

Table 21: ACOL-DG HM-1

PP Strategy	Existing B Crack Pre-Construction	Dry/Wet	Traffic	Alligator A+B Crack		Alligator A Crack		Alligator B Crack	
				Year to 10% crack	Year to 25% crack	Year to 10% crack	Year to 25% crack	Year to 10% crack	Year to 25% crack
ACOL-DG-HM1	x ≤ 10%	Dry	Low	3	5	10		5	6
			High	3	5			4	
		Wet	Low	6	7	7	9	7	11
			High	6	7	8	11	6	12
	10% < x ≤ 25%	Dry	Low	3	5	12	15	5	6
			High	3	5	7		4	5
		Wet	Low	4	7	7		7	7
			High	4	5	6		5	7
	x > 25%	Dry	Low	3	6	6		4	7
			High	2	3	6	9	3	4
		Wet	Low	3	4	4	9	8	
			High	3	6	6		4	

Table 22: ACOL-DG CapM

Action Category	Existing B Crack Pre-Construction	Dry/Wet	Traffic	Alligator A+B Crack		Alligator A Crack		Alligator B Crack	
				Year to 10% crack	Year to 25% crack	Year to 10% crack	Year to 25% crack	Year to 10% crack	Year to 25% crack
ACOL-DG CAPM	x ≤ 10%	Dry	Low	8	8			4	8
			High		6			7	6
		Wet	Low	5				5	
			High						
	10% < x ≤ 25%	Dry	Low	6	7	5			
			High						
		Wet	Low	4	7		7	5	
			High						
	x > 25%	Dry	Low						
			High						
		Wet	Low						
			High						

Table 23: ACOL-DG Rehab

PP Strategy	Existing B Crack Pre-Construction	Dry/Wet	Traffic	Alligator A+B Crack		Alligator A Crack		Alligator B Crack	
				Year to 10% crack	Year to 25% crack	Year to 10% crack	Year to 25% crack	Year to 10% crack	Year to 25% crack
ACOL-DG-REH	x ≤ 10%	Dry	Low					11	11
			High	7					
		Wet	Low	4	6	5		6	7
			High	6					
	10% < x ≤ 25%	Dry	Low	8				11	
			High	10	11	11		12	
		Wet	Low						
			High	6	9				9
	x > 25%	Dry	Low	9	11	11		10	12
			High	8	12	12	12	8	13
		Wet	Low						
			High	6				6	

Table 24: ACOL-OG HM-1

PP Strategy	Existing B Crack Pre-Construction	Dry/Wet	Traffic	Alligator A+B Crack		Alligator A Crack		Alligator B Crack	
				Year to 10% crack	Year to 25% crack	Year to 10% crack	Year to 25% crack	Year to 10% crack	Year to 25% crack
ACOLOG	x ≤ 10%	Dry	Low	3					
			High		5	5			
		Wet	Low						
			High						
	10% < x ≤ 25%	Dry	Low	2	3			3	3
			High	2	4	4	5	4	
		Wet	Low						
			High	6				7	
	x > 25%	Dry	Low	2	3	5		2	3
			High	3	5			4	5
		Wet	Low						
			High	2	3			2	9

Table 25: ACOL-RAC HM-1

PP Strategy	Existing B Crack Pre-Construction	Dry/Wet	Traffic	Alligator A+B Crack		Alligator A Crack		Alligator B Crack	
				Year to 10% crack	Year to 25% crack	Year to 10% crack	Year to 25% crack	Year to 10% crack	Year to 25% crack
ACOLRAC	x ≤ 10%	Dry	Low						
			High						
		Wet	Low	6				6	
			High	2		2		4	
	10% < x ≤ 25%	Dry	Low						
			High						
		Wet	Low	8		8		10	
			High	1	2				
	x > 25%	Dry	Low						
			High	5					
		Wet	Low						
			High						

Table 26: ACOL-RACO HM-1

PP Strategy	Existing B Crack Pre-Construction	Dry/Wet	Traffic	Alligator A+B Crack		Alligator A Crack		Alligator B Crack	
				Year to 10% crack	Year to 25% crack	Year to 10% crack	Year to 25% crack	Year to 10% crack	Year to 25% crack
ACOLRACO	x ≤ 10%	Dry	Low						
			High	5	4	4	4		
		Wet	Low						
			High						
	10% < x ≤ 25%	Dry	Low						
			High						
		Wet	Low						
			High						
	x > 25%	Dry	Low						
			High						
		Wet	Low						
			High						

Table 27: Chip Seal

PP Strategy	Existing B Crack Pre-Construction	Dry/Wet	Traffic	Alligator A+B Crack		Alligator A Crack		Alligator B Crack	
				Year to 10% crack	Year to 25% crack	Year to 10% crack	Year to 25% crack	Year to 10% crack	Year to 25% crack
CS-AC	x ≤ 10%	Dry	Low	4				9	
			High	6	7			6	
		Wet	Low	5	13	13		9	
			High	3	5	5		5	6
	10% < x ≤ 25%	Dry	Low	1	3			1	3
			High	1	2			2	5
		Wet	Low	2	6	6		3	7
			High	2	3	5		2	4
	x > 25%	Dry	Low	7	12	12	12	14	14
			High	1	2	2		2	3
		Wet	Low	1	2	2		1	7
			High	1	3	7		1	3

Table 28: Digout

PP Strategy	Existing B Crack Pre-Construction	Dry/Wet	Traffic	Alligator A+B Crack		Alligator A Crack		Alligator B Crack	
				Year to 10% crack	Year to 25% crack	Year to 10% crack	Year to 25% crack	Year to 10% crack	Year to 25% crack
Digout	x ≤ 10%	Dry	Low						
			High						
		Wet	Low	1		1			
			High						
	10% < x ≤ 25%	Dry	Low	2				2	
			High	2				2	
		Wet	Low	1	2			1	2
			High	1	1	1	1	1	1
	x > 25%	Dry	Low	1				1	
			High						
		Wet	Low	1	2			2	
			High	1	1	2	2	1	1

Table 29: Slurry

PP Strategy	Existing B Crack Pre-Construction	Dry/Wet	Traffic	Alligator A+B Crack		Alligator A Crack		Alligator B Crack	
				Year to 10% crack	Year to 25% crack	Year to 10% crack	Year to 25% crack	Year to 10% crack	Year to 25% crack
Slurry	x ≤ 10%	Dry	Low	2				2	
			High						
		Wet	Low	2	4				6
			High	3	3	4		3	4
	10% < x ≤ 25%	Dry	Low						
			High						
		Wet	Low						
			High						
	x > 25%	Dry	Low						
			High						
		Wet	Low						
			High						

6.4 Annualized Pavement Treatment Costs

The material provided in this section is not part of the deliverable of this project. UCPRC believes that the life-cycle cost analysis will provide definitive knowledge on whether, and at what stage of cracking, pavement preservation treatments should be applied on a policy level. Given that, pavement service lives and Equivalent Uniform Annual Cost (EUAC) figures can be used to select the most appropriate treatment, depending on the program and budget planning constraints. The EUAC calculated here is the initial construction cost discounted over the 50th percentile life calculated in the previous section.

Looking at the cost of various treatments for pavements in different conditions in terms of EUAC over their service life period enables the most cost-effective treatment to be selected. If the expected life values were known more completely with better data (in Table 20 through Table 29), EUAC costs (discounted

appropriately) could be used to plan annual budgets based on historical performance of preservation treatments on the highway network. Table 30 through Table 37 present the agency’s construction cost (pavement costs only) in terms of EUAC for the various pavement treatments (thousands of dollars per lane-mile per year).

The EAUC is reasonable only if the expected life (in Table 20 to Table 29) is reasonable. Only agency construction costs are used in the EUAC calculation, while the data (pavement only) are from Caltrans’ *RealCost* User Manual (7). Cost data in the manual are derived primarily from calculations performed for the “State of the Pavement Report” by the Division of Maintenance (2006 version), which carry with them the assumptions used in those calculations and which support cost multipliers from other sources. A more detailed description of the cost data is included in the manual. Agency costs alone were considered for this study because hourly traffic flows and construction schedules needed for calculating user costs were not available for the projects included in the study, and also because the time necessary to attempt to estimate those data for “typical” projects was outside the scope of this study.

Table 30: ACOL-DG HM-1 Annualized Cost per Lane-Mile (x \$1,000)

Action Category	Existing B Crack Pre-Construction	Dry/Wet	Traffic	Alligator A+B Crack		Alligator A Crack		Alligator B Crack	
				Year to 10% crack	Year to 25% crack	Year to 10% crack	Year to 25% crack	Year to 10% crack	Year to 25% crack
ACOL-DG-HM1	x ≤10%	Dry	Low	(\$12.18)	(\$7.59)	(\$4.17)		(\$7.59)	(\$6.45)
			High	(\$12.18)	(\$7.59)			(\$9.31)	
		Wet	Low	(\$6.45)	(\$5.63)	(\$5.63)	(\$4.55)	(\$5.63)	(\$3.86)
			High	(\$6.45)	(\$5.63)	(\$5.02)	(\$3.86)	(\$6.45)	(\$3.60)
	10%<x≤25%	Dry	Low	(\$12.18)	(\$7.59)	(\$3.60)	(\$3.04)	(\$7.59)	(\$6.45)
			High	(\$12.18)	(\$7.59)	(\$5.63)		(\$9.31)	(\$7.59)
		Wet	Low	(\$9.31)	(\$5.63)	(\$5.63)		(\$5.63)	(\$5.63)
			High	(\$9.31)	(\$7.59)	(\$6.45)		(\$7.59)	(\$5.63)
	x > 25%	Dry	Low	(\$12.18)	(\$6.45)	(\$6.45)		(\$9.31)	(\$5.63)
			High	(\$17.92)	(\$12.18)	(\$6.45)	(\$4.55)	(\$12.18)	(\$9.31)
		Wet	Low	(\$12.18)	(\$9.31)	(\$9.31)	(\$4.55)	(\$5.02)	
			High	(\$12.18)	(\$6.45)	(\$6.45)		(\$9.31)	

Construction cost is \$33,800 per lane mile, according to the draft *RealCost* User Manual.

Table 31: ACOL-DG CapM Annualized Cost per Lane-Mile (x \$1,000)

Action Category	Existing B Crack Pre-Construction	Dry/Wet	Traffic	Alligator A+B Crack		Alligator A Crack		Alligator B Crack	
				Year to 10% crack	Year to 25% crack	Year to 10% crack	Year to 25% crack	Year to 10% crack	Year to 25% crack
ACOL-DG-CAPM	x ≤10%	Dry	Low	(\$17.53)	(\$17.53)			(\$32.51)	(\$17.53)
			High		(\$22.51)			(\$19.66)	(\$22.51)
		Wet	Low	(\$26.51)				(\$26.51)	
			High						
	10%<x≤25%	Dry	Low	(\$22.51)	(\$19.66)	(\$26.51)			
			High						
		Wet	Low	(\$32.51)	(\$19.66)		(\$19.66)	(\$26.51)	
			High						
	x> 25%	Dry	Low						
			High						
		Wet	Low						
			High						

Construction cost is \$118,000 per lane mile, according to the draft *RealCost* User Manual.

Table 32: ACOL-DG Rehabilitation Annualized Cost per Lane-Mile (x \$1,000)

Action Category	Existing B Crack Pre-Construction	Dry/Wet	Traffic	Alligator A+B Crack		Alligator A Crack		Alligator B Crack	
				Year to 10% crack	Year to 25% crack	Year to 10% crack	Year to 25% crack	Year to 10% crack	Year to 25% crack
ACOL-DG-REH	x ≤10%	Dry	Low				(\$34.13)		(\$34.13)
			High	(\$49.82)					
		Wet	Low	(\$82.37)	(\$57.04)	(\$67.16)		(\$57.04)	(\$49.82)
			High	(\$57.04)					
	10%<x≤25%	Dry	Low	(\$44.41)				(\$34.13)	
			High	(\$36.86)	(\$34.13)	(\$34.13)		(\$31.86)	
		Wet	Low						
			High	(\$57.04)	(\$40.21)				(\$40.21)
	x> 25%	Dry	Low	(\$40.21)	(\$34.13)	(\$34.13)		(\$36.86)	(\$31.86)
			High	(\$44.41)	(\$31.86)	(\$31.86)	(\$31.86)	(\$44.41)	(\$29.94)
		Wet	Low						
			High	(\$57.04)				(\$57.04)	

Construction cost is \$299,000 per lane mile, according to the draft *RealCost* User Manual.

Table 33: ACOL-OG HM-1 Annualized Cost per Lane-Mile (x \$1,000)

Action Category	Existing B Crack Pre-Construction	Dry/Wet	Traffic	Alligator A+B Crack		Alligator A Crack		Alligator B Crack	
				Year to 10% crack	Year to 25% crack	Year to 10% crack	Year to 25% crack	Year to 10% crack	Year to 25% crack
ACOLOG-HM1	x ≤10%	Dry	Low	(\$12.32)					
			High		(\$7.68)	(\$7.68)			
		Wet	Low						
			High						
	10%<x≤25%	Dry	Low	(\$18.13)	(\$12.32)			(\$12.32)	(\$12.32)
			High	(\$18.13)	(\$9.42)	(\$9.42)	(\$7.68)	(\$9.42)	
		Wet	Low						
			High	(\$6.52)				(\$5.70)	
	x> 25%	Dry	Low	(\$18.13)	(\$12.32)	(\$7.68)		(\$18.13)	(\$12.32)
			High	(\$12.32)	(\$7.68)			(\$9.42)	(\$7.68)
		Wet	Low						
			High	(\$18.13)	(\$12.32)			(\$18.13)	(\$4.60)

Construction cost is \$34,200 per lane mile, according to the draft *RealCost* User Manual.

Table 34: ACOL-RAC HM-1 Annualized Cost per Lane-Mile (x \$1,000)

Action Category	Existing B Crack Pre-Construction	Dry/Wet	Traffic	Alligator A+B Crack		Alligator A Crack		Alligator B Crack	
				Year to 10% crack	Year to 25% crack	Year to 10% crack	Year to 25% crack	Year to 10% crack	Year to 25% crack
ACOLRAC-HM1	x ≤ 10%	Dry	Low						
			High						
		Wet	Low	(\$7.90)					(\$7.90)
			High	(\$21.95)		(\$21.95)			(\$11.41)
	10% < x ≤ 25%	Dry	Low						
			High						
		Wet	Low	(\$6.15)		(\$6.15)			(\$5.10)
			High	(\$43.06)	(\$21.95)				
	x > 25%	Dry	Low						
			High	(\$9.30)					
		Wet	Low						
			High						

Construction cost is \$41,400 per lane mile, according to the draft *RealCost* User Manual.

Table 35: Chip Seal Annualized Cost per Lane-Mile (x \$1,000)

Action Category	Existing B Crack Pre-Construction	Dry/Wet	Traffic	Alligator A+B Crack		Alligator A Crack		Alligator B Crack	
				Year to 10% crack	Year to 25% crack	Year to 10% crack	Year to 25% crack	Year to 10% crack	Year to 25% crack
ChipSeal-AC	x ≤ 10%	Dry	Low	(\$4.88)					(\$2.38)
			High	(\$3.38)	(\$2.95)				(\$3.38)
		Wet	Low	(\$3.98)	(\$1.77)	(\$1.77)			(\$2.38)
			High	(\$6.38)	(\$3.98)	(\$3.98)			(\$3.98) (\$3.38)
	10% < x ≤ 25%	Dry	Low	(\$18.41)	(\$6.38)				(\$18.41) (\$6.38)
			High	(\$18.41)	(\$9.38)				(\$9.38) (\$3.98)
		Wet	Low	(\$9.38)	(\$3.38)	(\$3.38)			(\$6.38) (\$2.95)
			High	(\$9.38)	(\$6.38)	(\$3.98)			(\$9.38) (\$4.88)
	x > 25%	Dry	Low	(\$2.95)	(\$1.89)	(\$1.89)	(\$1.89)		(\$1.68) (\$1.68)
			High	(\$18.41)	(\$9.38)	(\$9.38)			(\$9.38) (\$6.38)
		Wet	Low	(\$18.41)	(\$9.38)	(\$9.38)			(\$18.41) (\$2.95)
			High	(\$18.41)	(\$6.38)	(\$2.95)			(\$18.41) (\$6.38)

Construction cost is \$17,700 per lane mile, according to the draft *RealCost* User Manual.

Table 36: Digout Annualized Cost per Lane-Mile (x \$1,000)

Action Category	Existing B Crack Pre-Construction	Dry/Wet	Traffic	Alligator A+B Crack		Alligator A Crack		Alligator B Crack	
				Year to 10% crack	Year to 25% crack	Year to 10% crack	Year to 25% crack	Year to 10% crack	Year to 25% crack
Digout	x ≤ 10%	Dry	Low						
			High						
		Wet	Low	(\$35.88)		(\$35.88)			
			High						
	10% < x ≤ 25%	Dry	Low	(\$18.29)					(\$18.29)
			High	(\$18.29)					(\$18.29)
		Wet	Low	(\$35.88)	(\$18.29)				(\$35.88) (\$18.29)
			High	(\$35.88)	(\$35.88)	(\$35.88)	(\$35.88)	(\$35.88)	(\$35.88)
	x > 25%	Dry	Low	(\$35.88)					(\$35.88)
			High						
		Wet	Low	(\$35.88)	(\$18.29)				(\$18.29)
			High	(\$35.88)	(\$35.88)	(\$18.29)	(\$18.29)	(\$35.88)	(\$35.88)

Construction cost is \$34,500 per lane mile, according to the draft *RealCost* User Manual.

Table 37: Slurry Annualized Cost per Lane-Mile (x \$1,000)

Action Category	Existing B Crack Pre-Construction	Dry/Wet	Traffic	Alligator A+B Crack		Alligator A Crack		Alligator B Crack	
				Year to 10% crack	Year to 25% crack	Year to 10% crack	Year to 25% crack	Year to 10% crack	Year to 25% crack
Slurry	x ≤ 10%	Dry	Low	(\$8.27)				(\$8.27)	
			High						
		Wet	Low	(\$8.27)	(\$4.30)				(\$2.98)
			High	(\$5.62)	(\$5.62)	(\$4.30)		(\$5.62)	(\$4.30)
	10% < x ≤ 25%	Dry	Low						
			High						
		Wet	Low						
			High						
	x > 25%	Dry	Low						
			High						
		Wet	Low						
			High						

Construction cost is \$15,600 per lane mile, according to the draft *RealCost* User Manual.

7 LIFE-CYCLE COST ANALYSIS

In this chapter, life-cycle cost analysis (LCCA) work is performed in the context of delivering the following two objectives, as stated in the project work plan:

1. Calculate life-cycle costs (LCC):

Construction cost information will be collected from the State of the Pavement Report (SOPR) and included in the draft life-cycle cost analysis manual developed by the UCPRC and the Caltrans Division of Design. Information for certain pavement preservation treatments is not included in the SOPR and will need to be provided by the Caltrans Division of Maintenance.

The typical life cycles and performance probabilities from this study will be used with the cost information to calculate net present value (NPV) for each scenario with and without applying pavement preservation treatments following the procedures and using information in the Caltrans draft LCCA manual. The analysis will be performed considering agency cost only, unless construction duration and scheduling information can be found for pavement preservation treatments.

2. Analyze timing and relative performance:

If a sufficient range of pavement condition data prior to placement of the pavement preservation treatment is found in the data available, an analysis will be made regarding the optimum timing of treatments with respect to pavement condition in terms of life-cycle cost.

Figure 10 presents the order of work conducted in this section to accomplish the LCCA objectives.

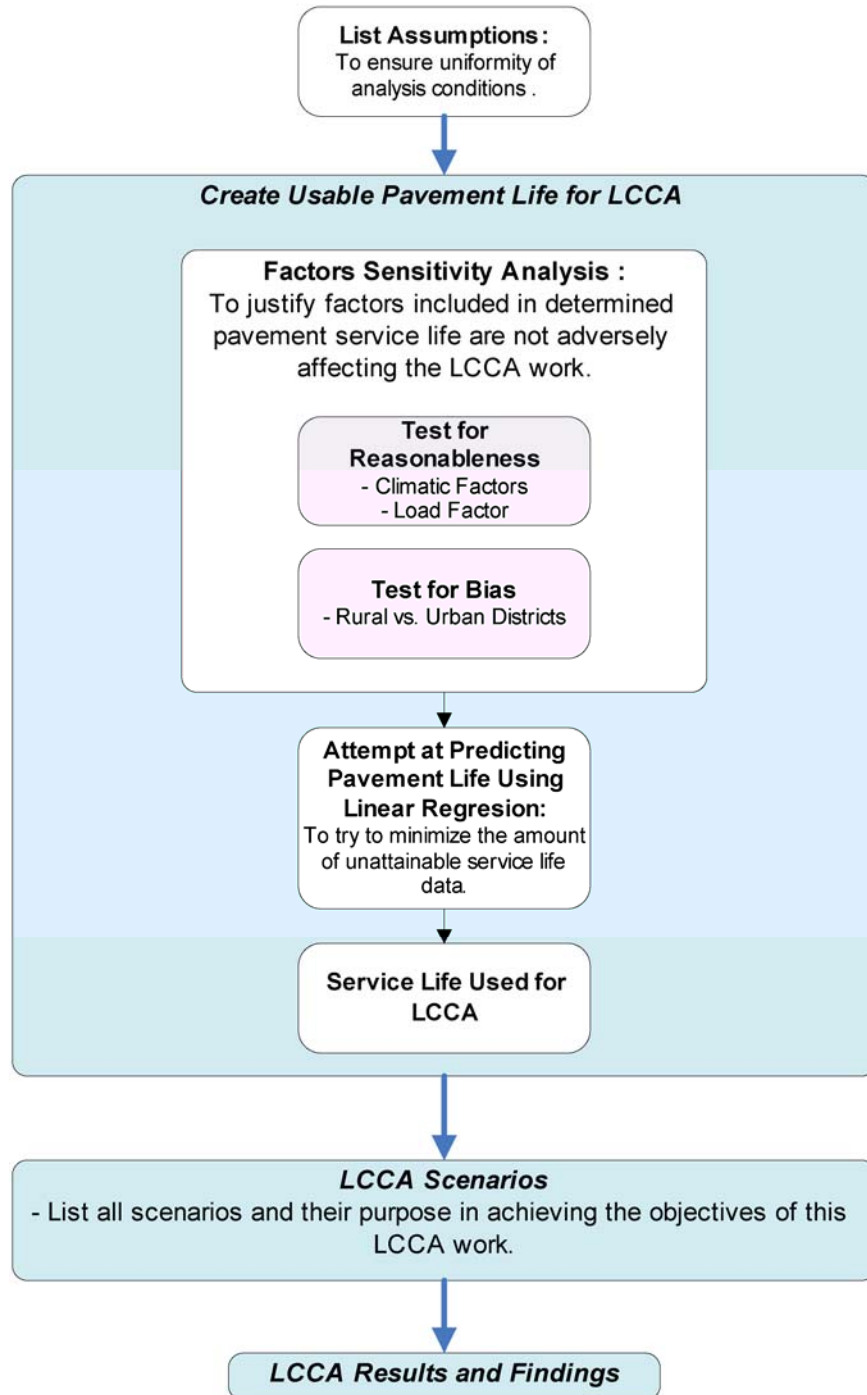

Figure 10: Process flowchart for LCCA.

7.1 Assumptions for LCCA

The cost of various pavement treatment sequences over a predefined analysis period needs to be calculated to achieve the above objectives. To limit the number of different treatment combinations, the following assumptions are made for all treatment sequences:

1. All existing cracking before current treatment means the amount of Alligator B cracking.
2. LCCA scenarios are evaluated for 20- and 35-year analysis periods.
3. Discount rate is set at a fixed 4 percent.
4. Rehabilitation treatment consists of conventional dense-graded overlay only.
5. HM-1 treatments are performed with either all ACOL (DG, OG, RAC) or all chip seal.
6. All HM-1 treatments are performed at less than 10 percent Alligator B cracking.
7. Pavement lives are based on findings derived from Pavement Condition Survey data.
8. LCCA will be performed only for treatments for which the UCPRC is able to derive an expected pavement life.

7.2 Factors Sensitivity Analysis

A new sensitivity analysis of factors affecting pavement life, here defined as the 50th percentile life to the given extent of cracking, was performed to check for reasonableness and to determine if certain factors could be consolidated with others or should be excluded. The factors analyzed consist of one load factor, AADTT (Average Annual Daily Truck Traffic), and four climatic factors: average annual precipitation (mm/yr); average annual minimum temperature (C°), which is the minimum temperature on the coldest day of the year average across many years; average annual minimum temperature (C°) in January; and average annual freeze-thaw cycles.

Sensitivity analyses are applied to HM-1 dense-graded overlay treatments, as this style of treatment has the greatest available sample data. Each factor is divided into four groups according to each of the quartiles from the collected sample database. The results show that none of these factors alone has a dominant effect on the performance of the pavement, hence all climatic factors are dropped from the LCCA work and only the load factor, AADTT, remains. Table 38 to Table 42 provide reasons why these factors are not considered in developing the pavement performance estimate used for LCCA. The red-bracketed values in each of the tables indicate examples of the conclusion drawn from each type of sensitivity study summarized in the text below each table for Table 38 to Table 42.

Table 38: AADTT Sensitivity Test Table

PP Strategy	Existing B Crack Pre-Construction	Traffic	Alligator A+B Crack		Alligator A Crack		Alligator B Crack		
			Year to 10% Crack	Year to 25% Crack	Year to 10% Crack	Year to 25% Crack	Year to 10% Crack	Year to 25% Crack	
ACOL-DG HM1	x ≤ 10%	≤ 39.8	6	}	8	8	9	7	11
		≤ 124.6	4		6	9	12	7	
		≤ 309.6	4		6	7	9	6	8
		> 309.6	5		9	11	9	12	
	10% < x ≤ 25%	≤ 39.8	4	}	7	7		6	7
		≤ 124.6	4		5	12		5	6
		≤ 309.6	4		5	6		5	6
		> 309.6	3		5	11		5	5
	x > 25%	≤ 39.8	2	}	4	4		4	7
		≤ 124.6	4		6	6		6	
		≤ 309.6	3		5	6	9	3	7
		> 309.6	2		3	4		3	3

In Table 38, the total cracking (Alligator A+B cracking) does not show a consistently decreasing pavement life as the truck traffic increases. For example, see values beside the brackets in Table 38. Some life values increase with increased traffic, and some decrease. The limited and unbalanced database of treatments and performance histories contributes to these trends.

Table 39: Average Annual Precipitation Sensitivity Test Table

PP Strategy	Existing B Crack Pre-Construction	Precipitation (mm)	Alligator A+B Crack		Alligator A Crack		Alligator B Crack		
			Year to 10% Crack	Year to 25% Crack	Year to 10% Crack	Year to 25% Crack	Year to 10% Crack	Year to 25% Crack	
ACOL-DG HM1	x ≤ 10%	≤ 325	4	5	10		5	5	
		≤ 464	4	5			6		
		≤ 855	6	7	7	9	9		
		> 855	7	7	7	9	8	10	
	10% < x ≤ 25%	≤ 325	4	4	}	11	15	5	5
		≤ 464	5	6				6	6
		≤ 855	5	5		6		7	7
		> 855	6	7		7		7	7
	x > 25%	≤ 325	3	3	}	6		3	4
		≤ 464	4	6		6		5	6
		≤ 855	4	6		6	9	7	
		> 855	4	4		4		4	

In Table 39, cracking does not show a consistently decreasing trend in pavement life as the amount of precipitation increases, which is inconsistent with the expectation that precipitation should have an adverse effect on pavement life. As noted in Section 5 of this technical memo, precipitation is a critical factor affecting pavement life based on observations from the WSDOT database, and pavement life should decrease as precipitation levels increase. The WSDOT database has many times more observations, and only one treatment: the equivalent of ACOL-DG.

Table 40: Average Annual Minimum Temperature Sensitivity Test Table

PP Strategy	Existing B Crack Pre-Construction	MinTemp (C)	Alligator A+B Crack		Alligator A Crack		Alligator B Crack	
			Year to 10% Crack	Year to 25% Crack	Year to 10% Crack	Year to 25% Crack	Year to 10% Crack	Year to 25% Crack
ACOL-DG HM1	x ≤ 10%	≤ -17.7	3	5	7		5	7
		≤ -7.6	6	8	8	9	8	10
		≤ -2.4	5	7	9		8	12
		> -2.4	6	8	8		7	9
	10% < x ≤ 25%	≤ -17.7	4	6	8	15	5	7
		≤ -7.6	5	6	7		5	7
		≤ -2.4	4	5	11		5	5
		> -2.4	4	5	4		5	10
	x > 25%	≤ -17.7	3	6	6		5	7
		≤ -7.6	4	6	6		8	
		≤ -2.4	3	4	4		3	5
		> -2.4	2	2	4		2	3

Again, as seen in Table 40, cracking does not show a consistently increasing trend in pavement life as the average annual minimum temperature increases. It is expected that pavement life in terms of cracking distress should increase as the minimum temperature rises. Again, based on the WSDOT experience, higher minimum temperatures should reduce the rate of cracking progression (6).

Table 41: Average Annual Minimum Temperature in January Sensitivity Test Table

PP Strategy	Existing B Crack Pre-Construction	Avg. Annual MinTemp in Jan.	Alligator A+B Crack		Alligator A Crack		Alligator B Crack	
			Year to 10% crack	Year to 25% crack	Year to 10% crack	Year to 25% crack	Year to 10% crack	Year to 25% crack
ACOL-DG HM1	A+B<10% x ≤10%	≤-5.9	4	6	10		5	
		≤-0.1	5	6	7		6	
		≤4	7	9	10		9	12
		>4						
	A+B≥10% x ≤10%	≤-5.9	3	6	7		5	7
		≤-0.1	6	8	8	9	8	10
		≤4	4	4	6	9	5	9
		>4	5	5	8		6	11
	10%<x≤25%	≤-5.9	5	6	8	15	6	7
		≤-0.1	6	6	7		6	7
		≤4	4	5			6	5
		>4	6	5			6	
	x> 25%	≤-5.9	4	6	6		5	7
		≤-0.1	5	6	6		9	
		≤4	3	3	4		3	4
		>4	3	4	7		4	4

As with the average minimum annual temperature, the trend of pavement life seen in Table 41 for cracking does not consistently increase as average minimum January temperature rises. This observation also contradicts what was learned from the study on the WSDOT database, where higher minimum temperature reduced the rate of crack progression (6).

Table 42: Average Annual Freeze-thaw Cycles Sensitivity Test Table

PP Strategy	Existing B Crack Pre-Construction	Avg Annual Free-Thaw cycle	Alligator A+B Crack		Alligator A Crack		Alligator B Crack	
			Year to 10% crack	Year to 25% crack	Year to 10% crack	Year to 25% crack	Year to 10% crack	Year to 25% crack
ACOL-DG HM1	A+B<10% x ≤10%	≤6						
		≤45	2	4	5	7	7	
		≤137	6	6		9	6	12
		>137	5	9	10		9	12
	A+B≥10% x ≤10%	≤6	3	4	4		4	
		≤45	5	7	6		7	8
		≤137	4	6	7		6	7
		>137	6	8	8	9	7	
	10%<x≤25%	≤6	2	5		4	3	6
		≤45	4	5	8		4	7
		≤137	4	7	9	15	5	7
		>137	5	6	7		6	7
	x> 25%	≤6	2	4	4		2	
		≤45	4	9	5			
		≤137	4	6	6		5	
		>137	4	6	6		5	7

Pavement life should increase with fewer freeze-thaw cycles. However, analysis does not show a consistent increase in pavement life versus decrease in number of freeze-thaw cycles, as seen in Table 42. Also, based on the cracking progression model study using WSDOT data, an increase in the number of freeze-thaw cycles increases the rate of cracking progression (6).

Before proceeding with the life-cycle cost analysis, a final evaluation was performed to check for bias with regard to urban versus rural sources of project data. Recall from Table 10 that over half of the HM-1 projects were located in Districts 2 and 8; nearly three fourths of the Rehabilitation projects were located in Districts 2 and 7. In this evaluation, Districts 7 and 8 represented urban projects, and District 2 projects were considered to be rural projects.

Table 43 presents expected pavement life for HM-1 projects using the ACOL-DG treatment based on the entire dataset (under the “Alligator B Crack” column heading) and based on projects from Districts 2 and 8 (noted in column headings). Differences are apparent but do not clearly show bias. Table 44 presents expected pavement life in a similar format that compares results both for the entire dataset and for projects in Districts 2 and 7. Bias is not indicated.

Table 43: ACOL-DG HM-1—Rural vs. Urban District Sensitivity Test Table

PP Strategy	Existing B Crack Pre-Construction	Dry/Wet	Traffic	Alligator B Crack		Alligator B Crack Rural (District 2 Only)		Alligator B Crack Urban (District 8 Only)	
				Year to 10% Crack	Year to 25% Crack	Year to 10% Crack	Year to 25% Crack	Year to 10% Crack	Year to 25% Crack
ACOL-DG-HM1	$x \leq 10\%$	Dry	Low	5	6	3	6		
			High	4		2		6	
		Wet	Low	7	11	7			
			High	6	12	6	10	4	
	$10\% < x \leq 25\%$	Dry	Low	5	6	4	8	2	3
			High	4	5	4	6	5	5
		Wet	Low	7	7	7	7	4	7
			High	5	7	6	7	4	4
	$x > 25\%$	Dry	Low	4	7	3	7		
			High	3	4	5	7	3	3
		Wet	Low	8		8		4	3
			High	4		5		4	3

Table 44: ACOL-DG Rehabilitation—Rural vs. Urban District Sensitivity Test Table

PP Strategy	Existing B Crack Pre-Construction	Dry/Wet	Traffic	Alligator B Crack		Alligator B Crack Rural (District 2 Only)		Alligator B Crack Urban (District 7 Only)	
				Year to 10% Crack	Year to 25% Crack	Year to 10% Crack	Year to 25% Crack	Year to 10% Crack	Year to 25% Crack
ACOL-DG-REH	$x \leq 10\%$	Dry	Low		11				11
			High			5	5	5	5
		Wet	Low	6	7			5	7
			High					5	
	$10\% < x \leq 25\%$	Dry	Low	11				11	
			High	12					
		Wet	Low						
			High		9				
	$x > 25\%$	Dry	Low	10	12			10	12
			High	8	13			8	8
		Wet	Low						
			High	6		2		6	

7.3 Attempt to Predict Pavement Performance by Linear Extrapolation

This section describes an effort to use linear regression to estimate pavement service life for datasets where the median did not reach cracking trigger levels of 10 percent and 25 percent. Figure 11 shows an example with linear regression applied to dense-graded asphalt concrete overlay rehabilitation. In this example, the linear regression is forced to intercept the origin, since a failure is not expected to happen immediately after the completion of any treatment work. The actual cumulative distribution function (CDF) from the data is plotted up to 11 years, ending at just below 50 percent, indicating that less than half the dataset reached the trigger of 10 percent cracking. The 50th percentile of failure can be estimated (approximately 12 years) from the trend-line.

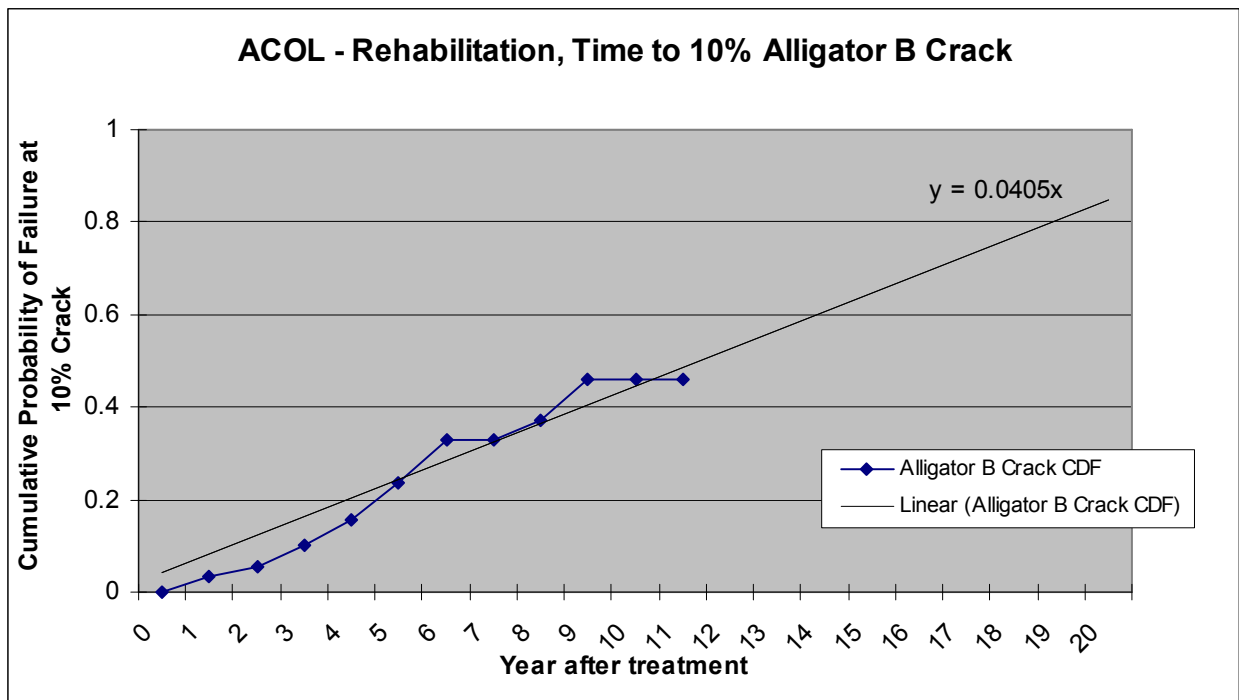

Figure 11: Example of pavement life prediction using linear regression.

Using regression analysis, median values were first estimated, then compared to actual data. Table 45 shows a comparison of actual pavement services lives, where available, to the service lives that were estimated with linear regression and the absolute value of the percentage differences.

Table 45: Median vs. Estimated ACOL-DG Rehabilitation Lives

PP Strategy	Existing B Crack Pre-Construction	Alligator B Crack					
		Year to 10% crack	Year to 10% crack (Trendline)	% Difference	Year to 25% crack	Year to 25% crack (Trendline)	% Difference
ACOL-DG REH	$x \leq 10\%$	N/A	13	N/A	11	16	45%
	$10\% < x \leq 25\%$	12	14	17%	N/A	25	N/A
	$x > 25\%$	10	9	10%	12	13	8%

As shown in Table 45, the difference between the observed 50th percentile versus the linearly estimated 50th percentile value range from 8 percent to 45 percent. Given this wide range of error, pavement service life estimated from linear regression was not used for LCCA.

7.4 Service Life Used for LCCA

All the climatic factors are eliminated in deriving pavement service lives for LCCA. Such lives are shown in Table 46 through Table 52. Traffic factors are not included in Table 46 through Table 48 because of insufficient sample sizes for each traffic category. Where climate and traffic factors are not shown in the table, all categories of traffic and climate have been pooled.

Table 46: Dense-Graded Asphalt Concrete Overlay (Rehabilitation) Performance

PP Strategy	Existing B Crack Preconstruction	Alligator B Crack	
		Year to 10% Crack	Year to 25% Crack
ACOL-DG REH	$x \leq 10\%$	N/A	11
	$10\% < x \leq 25\%$	12	N/A
	$x > 25\%$	10	12

Table 47: Dense-Graded Asphalt Concrete Overlay (CapM) Performance

PP Strategy	Existing B Crack Preconstruction	Alligator B Crack	
		Year to 10% Crack	Year to 25% Crack
ACOL-DG CAPM	$x \leq 10\%$	N/A	N/A
	$10\% < x \leq 25\%$	5	N/A
	$x > 25\%$	N/A	N/A

Table 48: Rubber Asphalt Concrete Overlay (CapM) Performance

PP Strategy	Existing B Crack Preconstruction	Alligator B Crack	
		Year to 10% Crack	Year to 25% Crack
ACOL-	$x \leq 10\%$	N/A	N/A
RAC-	$10\% < x \leq 25\%$	10	N/A
CAPM	$x > 25\%$	N/A	N/A

Table 49: Dense-Graded Asphalt Concrete Overlay (HM-1) Performance

PP Strategy	Existing B Crack Preconstruction	AADTT	Alligator B Crack	
			Year to 10% Crack	Year to 25% Crack
ACOL-DG-HM1	$A+B < 10\%$ $x \leq 10\%$	Low	7	N/A
		High	6	12
	$A+B \geq 10\%$ $x \leq 10\%$	Low	7	11
		High	6	10
	$10\% < x \leq 25\%$	Low	6	7
		High	5	6
	$x > 25\%$	Low	5	N/A
		High	3	4

Table 50: Rubber Asphalt Concrete Overlay (HM-1) Performance

PP Strategy	Existing B Crack Preconstruction	AADTT	Alligator B Crack	
			Year to 10% Crack	Year to 25% Crack
ACOL-RAC-HM1	$A+B < 10\%$ $x \leq 10\%$	Low	N/A	
		High	N/A	
	$A+B \geq 10\%$ $x \leq 10\%$	Low	N/A	
		High	N/A	
	$10\% < x \leq 25\%$	Low	N/A	
		High	1	1
	$x > 25\%$	Low	3	
		High	N/A	

Table 51: Open-Graded Asphalt Concrete Overlay (HM-1) Performance

PP Strategy	Existing B Crack Preconstruction	AADTT	Alligator B Crack	
			Year to 10% Crack	Year to 25%Crack
ACOL-OG-HM1	A+B<10% x ≤10%	Low	N/A	N/A
		High	N/A	N/A
	A+B≥10% x ≤10%	Low	N/A	N/A
		High	5	N/A
	10%<x≤25%	Low	N/A	N/A
		High	5	N/A
	x> 25%	Low	2	N/A
		High	3	5

Table 52: Chip Seal (HM-1) Performance

PP Strategy	Existing B Crack Preconstruction	AADTT	Year to 10% Crack	Year to 25% Crack
CS-AC-HM1	A+B<10% x ≤10%	Low	13	N/A
		High	6	N/A
	A+B≥10% x ≤10%	Low	3	N/A
		High	3	N/A
	10%<x≤25%	Low	3	7
		High	2	5
	x> 25%	Low	14	14
		High	2	3

7.5 LCCA Scenarios

Seven major sets of scenarios were created for comparison of life-cycle cost. Most of the major scenario sets consist of several combinations of scenarios as listed in Table 53 to Table 59. These subscenarios are listed according to the major scenario set to which they belong, as numbered in the first column of these tables. The numbers in the first two columns of the tables simply show the number of subscenarios included in each major scenario; for example, in Table 53 subscenarios 1.1 to 1.8 represent one subset. These LCCA scenarios are established with the goals of discovering the following:

1. Is it more beneficial to apply pavement preservation (HM-1) than to perform no maintenance at all?
2. Should pavement preservation be applied at an earlier or a later stage of cracking?
3. How do the life-cycle costs of various pavement treatment combinations compare?

All seven sets of scenarios are presented here for completeness, because they were considered for analysis. The life of each treatment in the LCCA scenarios is based on those indicated in Section 7.4 of this memo

in Table 46 to Table 52. LCCA for all scenarios were run based on the lives shown in Section 7.4. However, only Scenario 2 could produce outcomes that provided meaningful interpretation *because all other scenarios' results were unusable either because of a lack of data (e.g., CapM) or because they were not viable for practical application (e.g., performing rehabilitation at 10 percent Alligator B cracking).*

An example of how a LCCA scenario is sequenced is demonstrated here, using a dense-grade AC overlay case in major scenario Set No. 2:

1. Rehabilitation is performed at >25% Alligator B cracking.
2. Each stage of rehabilitation work is followed by two HM-1 dense-graded overlay treatments.
3. Each HM-1 dense-graded overlay treatment is performed at ($\leq 10\%$ Alligator B) and ($\leq 10\%$ alligator A+B) cracking.
4. Each HM-1 action is performed under both a high and low AADTT load.

Under such a scenario, lives of the Rehabilitation and HM-1 treatments are collected from Table 46 and Table 49. The life of Rehabilitation action is 10 years when it is performed at >25% existing Alligator B cracking. The life of the dense-grade overlay HM-1 action is 6 years when it is performed at ($\leq 10\%$ Alligator B) and ($\leq 10\%$ alligator A+B) cracking. Based on a 35-year analysis period, the sequence of this particular scenario is then:

Rehab@Year0 → DGAC HM-1@Year10 → DGAC HM-1@Year16 → Rehab@Year22 → DGAC HM-1@Year32 → End@Year35 (with 3 years of life left in the last HM-1 action as salvage value).

Table 53: LCCA Scenario List for Major Scenario Set No. 1

Scenario	Rehab performed at <10% Alligator B cracking	
1	Rehab@10% -- Rehab@10% -- Rehab@10% --	
	1st Set	Each rehab followed by two HM-1 treatments, HM-1 performed at ($\leq 10\%B$) & ($A+B \leq 10\%$)
	1.1 to 1.8	Rehab@10% -- HM1@10% -- HM1@10% -- Rehab@10% -- HM1@10% -- HM1@10% --
		x4 for four kinds of HM1 treatment (ACOL-DG, ACOL-RAC, ACOL-OG, AC Chipseal)
		x2 for two levels of traffic level (High, Low)
	2nd Set	Each rehab followed by two HM-1 treatments, HM-1 performed at ($\leq 10\%B$) & ($A+B > 10\%$)
	1.9 to 1.16	Rehab@10% -- HM1@10% -- HM1@10% -- Rehab@10% -- HM1@10% -- HM1@10% --
		x4 for four kinds of HM1 treatment (ACOL-DG, ACOL-RAC, ACOL-OG, AC Chipseal)
		x2 for two levels of traffic level (High, Low)
	3rd Set	Rehab followed by only HM-1 treatments, HM-1 performed at ($\leq 10\%B$) & ($A+B \leq 10\%$)
	1.17 to 1.24	Rehab@10% -- HM1@10% -- HM1@10% -- HM1@10% -- HM1@10% --
		x4 for four kinds of HM1 treatment (ACOL-DG, ACOL-RAC, ACOL-OG, AC Chipseal)
		x2 for two levels of traffic level (High, Low)
4th Set	Rehab followed by only HM-1 treatments, HM-1 performed at ($\leq 10\%B$) & ($A+B > 10\%$)	
1.25 to 1.32	Rehab@10% -- HM1@10% -- HM1@10% -- HM1@10% -- HM1@10% --	
	x4 for four kinds of HM1 treatment (ACOL-DG, ACOL-RAC, ACOL-OG, AC Chipseal)	
	x2 for two levels of traffic level (High, Low)	

Set No. 1 scenarios focused on life-cycle cost (LCC) if rehabilitation were performed at earlier stages of Alligator B cracking (less than 10 percent), which is much lower than the current Caltrans trigger of greater than 25 percent Alligator B cracking. This set of scenarios was not studied due to lack of data and lack of viability for practical application.

Table 54: LCCA Scenario List for Major Scenario Set No. 2

Scenario	Rehab performed at >25% Alligator B cracking	
2	Rehab@25% -- Rehab@25% -- Rehab@25% --	
	1st Set	Each rehab followed by two HM-1 treatments, HM-1 performed at ($\leq 10\%B$) & ($A+B \leq 10\%$)
	2.1 to 2.8	Rehab@25% -- HM1@10% -- HM1@10% -- Rehab@25% -- HM1@10% -- HM1@10% --
		x4 for four kinds of HM1 treatment (ACOL-DG, ACOL-RAC, ACOL-OG, AC Chipseal)
		x2 for two levels of traffic level (High, Low)
	2nd Set	Each rehab followed by two HM-1 treatments, HM-1 performed at ($\leq 10\%B$) & ($A+B > 10\%$)
	2.9 to 2.16	Rehab@25% -- HM1@10% -- HM1@10% -- Rehab@25% -- HM1@10% -- HM1@10% --
		x4 for four kinds of HM1 treatment (ACOL-DG, ACOL-RAC, ACOL-OG, AC Chipseal)
		x2 for two levels of traffic level (High, Low)
	3rd Set	Rehab followed by only HM-1 treatments, HM-1 performed at ($\leq 10\%B$) & ($A+B \leq 10\%$)
	2.17 to 2.24	Rehab@25% -- HM1@10% -- HM1@10% -- HM1@10% -- HM1@10% --
		x4 for four kinds of HM1 treatment (ACOL-DG, ACOL-RAC, ACOL-OG, AC Chipseal)
		x2 for two levels of traffic level (High, Low)
4th Set	Rehab followed by only HM-1 treatments, HM-1 performed at ($\leq 10\%B$) & ($A+B > 10\%$)	
2.25 to 2.32	Rehab@25% -- HM1@10% -- HM1@10% -- HM1@10% -- HM1@10% --	
	x4 for four kinds of HM1 treatment (ACOL-DG, ACOL-RAC, ACOL-OG, AC Chipseal)	
	x2 for two levels of traffic level (High, Low)	
5th Set	Each rehab followed by two HM-1 treatments, HM-1 performed at ($> 25\%B$)	
2.33 to 2.40	Rehab@25% -- HM1@25% -- HM1@25% -- Rehab@25% -- HM1@25% -- HM1@25% --	
	x4 for four kinds of HM1 treatment (ACOL-DG, ACOL-RAC, ACOL-OG, AC Chipseal)	
	x2 for two levels of traffic level (High, Low)	
6th Set	Rehab followed by only HM-1 treatments, HM-1 performed at ($> 25\%B$)	
2.41 to 2.48	Rehab@25% -- HM1@25% -- HM1@25% -- HM1@25% -- HM1@25% --	
	x4 for four kinds of HM1 treatment (ACOL-DG, ACOL-RAC, ACOL-OG, AC Chipseal)	
	x2 for two levels of traffic level (High, Low)	

Scenarios in set No. 2 focus on the LCC of pavements when rehabilitation activities are performed at greater than 25 percent Alligator B cracking. For example, subscenarios 2.1 to 2.8 would be:

- 2.1 Under low traffic, each rehabilitation is performed at 25% cracking and is followed by two ACOL-DG actions at 10% cracking at HM-1 level.
- 2.2 Under low traffic, each rehabilitation is performed at 25% cracking and is followed by two ACOL-RAC action at 10% cracking at HM-1 level.
- 2.3 Under low traffic, each rehabilitation is performed at 25% cracking and is followed by two ACOL-OG actions at 10% cracking at HM-1 level.
- 2.4 Under low traffic, each rehabilitation is performed at 25% cracking and is followed by two chip seal actions at 10% cracking.
- 2.5 Under high traffic, each rehabilitation is performed at 25% cracking and is followed by two ACOL-DG actions at 10% cracking at HM-1 level.
- 2.6 Under high traffic, each rehabilitation is performed at 25% cracking and is followed by two ACOL-DRAC actions at 10% cracking at HM-1 level.
- 2.7 Under high traffic, each rehabilitation is performed at 25% cracking and is followed by two ACOL-OG actions at 10% cracking at HM-1 level.
- 2.8 Under high traffic, each rehabilitation is performed at 25% cracking and is followed by two chip seal actions at 10% cracking.

This set of scenarios also reflects the current Caltrans practice by triggering a rehabilitation action only when Alligator B cracking exceeds 25 percent. Subscenarios (5th and 6th sets) included under major scenario No. 2 demonstrate the LCC of pavement under the current Caltrans practice of performing most of the HM-1 treatments when Alligator B cracking has exceeded 25 percent versus the expected LCC if HM-1 treatments are performed at lower levels of cracking.

Table 55: LCCA Scenario List for Major Scenario Set No. 3

Scenario	CapM performed at <10% Alligator B cracking
3	CapM@10% -- CapM@10% -- CapM@10% -- CapM@10% --
1st Set	Each CapM followed by two HM-1 treatments, HM-1 performed at ($\leq 10\%B$) & ($A+B \leq 10\%$)
3.1 to 3.8	CapM@10% -- HM1@10% -- HM1@10% -- CapM@10% -- HM1@10% -- HM1@10% -- x4 for four kinds of HM1 treatment (ACOL-DG, ACOL-RAC, ACOL-OG, AC Chipseal) x2 for two levels of traffic level (High, Low)
2nd Set	Each CapM followed by two HM-1 treatments, HM-1 performed at ($\leq 10\%B$) & ($A+B > 10\%$)
3.9 to 3.16	CapM@10% -- HM1@10% -- HM1@10% -- CapM@10% -- HM1@10% -- HM1@10% -- x4 for four kinds of HM1 treatment (ACOL-DG, ACOL-RAC, ACOL-OG, AC Chipseal) x2 for two levels of traffic level (High, Low)
3rd Set	CapM followed by only HM-1 treatments, HM-1 performed at ($\leq 10\%B$) & ($A+B \leq 10\%$)
3.17 to 3.24	CapM@10% -- HM1@10% -- HM1@10% -- HM1@10% -- HM1@10% -- x4 for four kinds of HM1 treatment (ACOL-DG, ACOL-RAC, ACOL-OG, AC Chipseal) x2 for two levels of traffic level (High, Low)
4th Set	CapM followed by only HM-1 treatments, HM-1 performed at ($\leq 10\%B$) & ($A+B > 10\%$)
3.25 to 3.32	CapM@10% -- HM1@10% -- HM1@10% -- HM1@10% -- HM1@10% -- x4 for four kinds of HM1 treatment (ACOL-DG, ACOL-RAC, ACOL-OG, AC Chipseal) x2 for two levels of traffic level (High, Low)

Scenario set No. 3 presents the expected LCC of pavement maintenance sequences when activities consist of only CapM treatments and their respective HM-1 treatments' effects. Inadequate data for CapM projects precluded LCC evaluation.

Table 56: LCCA Scenario List for Major Scenario Set No. 4

Scenario	All CapM performed at >25% Alligator B cracking
4	CapM@25% -- CapM@25% -- CapM@25% -- CapM@25% --

Scenario set No. 4 reflects the expected LCC of pavement when only CapM maintenance treatments are performed and they are applied when Alligator B cracking exceeds 25 percent. This scenario would demonstrate the LCC difference when CapM treatments are performed in the later stages of cracking versus scenario set No. 3, when pavements are treated at an earlier stage of cracking. Lack of CapM data prevented analysis.

Table 57: LCCA Scenario List for Major Scenario Set No. 5

Scenario	Rehab and CapM alternating at <10% Alligator B cracking	
5	Rehab@10% -- CapM@10% -- Rehab@10% -- CapM@10% -- Rehab@10% --	
	1st Set	Each rehab/CapM followed by two HM-1 treatments, HM-1 performed at ($\leq 10\%B$) & ($A+B \leq 10\%$)
	5.1 to 5.8	Rehab@10% -- HM1@10% -- HM1@10% -- CapM@10% -- HM1@10% -- HM1@10% -- Rehab@10% -- x4 for four kinds of HM1 treatment (ACOL-DG, ACOL-RAC, ACOL-OG, AC Chipseal) x2 for two levels of traffic level (High, Low)
	2nd Set	Each rehab/CapM followed by two HM-1 treatments, HM-1 performed at ($\leq 10\%B$) & ($A+B > 10\%$)
	5.9 to 5.16	Rehab@10% -- HM1@10% -- HM1@10% -- CapM@10% -- HM1@10% -- HM1@10% -- Rehab@10% -- x4 for four kinds of HM1 treatment (ACOL-DG, ACOL-RAC, ACOL-OG, AC Chipseal) x2 for two levels of traffic level (High, Low)

In scenario set No. 5, instead of having the same major maintenance treatments throughout the analysis period, rehabilitation and CapM actions are assumed to alternate within each analysis sequence. The two sets of subscenarios (1st Set vs. 2nd Set) demonstrate the cost-effectiveness of performing HM-1 treatments earlier versus later in the cracking stage when major maintenance treatments are not unique. This set was not included due to lack of CapM data and the impracticality of rehabilitation at only 10 percent cracking.

Table 58: LCCA Scenario List for Major Scenario Set No. 6

Scenario	Rehab followed by one CapM, alternating at >25% Alligator B cracking
6	Rehab@25% -- CapM@25% -- Rehab@25% -- CapM@25% -- Rehab@25% --

Scenario set No. 6 focuses on alternating use of major maintenance activities in the later stages of cracking (greater than 25 percent Alligator B cracking) versus scenarios in set No. 5, in which the pavement is treated at less than 10 percent of Alligator B cracking. Lack of CapM data prevented analysis.

Table 59: LCCA Scenario List for Major Scenario Set No. 7

Scenario	Rehab and CapM alternating at >25% Alligator B cracking	
7	Rehab@25% -- CapM@25% -- CapM@25% -- Rehap@25% -- CapM@25% -- CapM@25% -- Rehab@25% --	
	1st Set	Each rehab/CapM followed by two HM-1 treatments, HM-1 performed at ($\leq 10\%B$) & ($A+B \leq 10\%$)
	7.1 to 7.8	Rehab@25% -- HM1@10% -- HM1@10% -- CapM@25% -- HM1@10% -- HM1@10% -- CapM@25% -- x4 for four kinds of HM1 treatment (ACOL-DG, ACOL-RAC, ACOL-OG, AC Chipseal) x2 for two levels of traffic level (High, Low)
	2nd Set	Each rehab/CapM followed by two HM-1 treatments, HM-1 performed at ($\leq 10\%B$) & ($A+B > 10\%$)
	7.9 to 7.16	Rehab@25% -- HM1@10% -- HM1@10% -- CapM@25% -- HM1@10% -- HM1@10% -- CapM@25% -- x4 for four kinds of HM1 treatment (ACOL-DG, ACOL-RAC, ACOL-OG, AC Chipseal) x2 for two levels of traffic level (High, Low)

The scenarios in set No. 7 further expand the various pavement treatment combinations. Each rehabilitation is followed by two CapM treatments. The two subsets (1st Set vs. 2nd Set) are used to identify the cost-effectiveness of performing HM-1 treatments to pavements earlier in the cracking stages. Lack of CapM data prevented analysis.

7.6 LCCA Results and Findings

Results from a life-cycle cost analysis of those scenarios evaluated show the following:

1. It is more cost-effective to apply preservation treatments than to perform no maintenance between rehabilitations.
2. It is more cost-effective to apply preservation treatments at earlier stages of cracking.
3. Comparing different combinations of treatments was severely hampered by limited data.

Details of the LCCA results are discussed in the following three sections.

7.6.1 LCCA Objective 1: Is It More Beneficial to Apply Pavement Preservation (HM-1) Versus No Maintenance?

Based on Table 60, for rehabilitation done at greater than 25 percent Alligator B cracking, the following was observed when compared with the subscenario of only rehabilitation within no maintenance treatments (first row in the table):

- When preventive actions are performed at less than 10 percent Alligator B cracking, a minimum saving of 27 percent is achieved over a 20-year analysis period.
- When preventive actions are performed at less than 10 percent Alligator B cracking, a minimum saving of 26 percent is achieved over a 35-year analysis period.
- Scenarios with preventive actions done at the very late stages of cracking (greater than 25 percent Alligator B cracking) reflect Caltrans practice during the period studied. All scenarios show that at least a 13 percent saving in LCC is achieved by applying preventive maintenance (dense-graded asphalt overlays) even when cracking is very high (greater than 25 percent).

Table 60: LCC of Preventive vs. No Preventive Actions (Rehabilitation at >25% Alligator B Cracking)—Dense-Graded Overlay

Scenario Set No.2 - Rehabilitation Treated at >25% Alligator B Crack	Existing B Crack Pre-Constructn	HM-1 Treatment = DGAC overlay			
		LCC over 20 Years in \$1000/mi/ln (Cost reduction vs. no HM-1's)		LCC over 35 Years in \$1000/mi/ln (Cost reduction vs. no HM-1's)	
		Low AADTT	High AADTT	Low AADTT	High AADTT
Rehab performed at >25% Alligator B cracking	No HM-1's	456.6		456.6	
Each rehab followed by two HM-1 treatments, HM-1 performed at ($\leq 10\%B$) & ($A+B \leq 10\%$)	A+B<10% $x \leq 10\%$		333.3 (27%)		426.1 (29%)
Rehab followed by only HM-1 treatments, HM-1 performed at ($\leq 10\%B$) & ($A+B \leq 10\%$)			333.3 (27%)		369.6 (39%)
Each rehab followed by two HM-1 treatments, HM-1 performed at ($\leq 10\%B$) & ($A+B > 10\%$)	A+B $\geq 10\%$ $x \leq 10\%$	332 (27%)	333.8 (27%)	425.4 (29%)	447.7 (26%)
Rehab followed by only HM-1 treatments, HM-1 performed at ($\leq 10\%B$) & ($A+B > 10\%$)		332 (27%)	333.8 (27%)	360.2 (40%)	369.6 (39%)
Each rehab followed by two HM-1 treatments, HM-1 performed at (> 25%B)	X>25%		396.5 (13%)		484.3 (20%)
Rehab followed by only HM-1 treatments, HM-1 performed at (> 25%B)			343.7 (25%)		387.7 (36%)

Table 61: LCC of Preventive vs. No Preventive Actions (Rehabilitation at >25% Alligator B Cracking)—Chip Seal

Scenario Set No.2 - Rehabilitation Treated at >25% Alligator B Crack	Existing B Crack Pre-Constructn	HM-1 Treatment = AC Chipseal			
		LCC over 20 Years in \$1000/mi/ln (Cost reduction vs. no HM-1's)		LCC over 35 Years in \$1000/mi/ln (Cost reduction vs. no HM-1's)	
		Low AADTT	High AADTT	Low AADTT	High AADTT
Rehab performed at >25% Alligator B cracking	No HM-1's	456.6		456.6	
Each rehab followed by two HM-1 treatments, HM-1 performed at ($\leq 10\%B$) & ($A+B \leq 10\%$)	A+B<10% $x \leq 10\%$	309.9 (32%)			
Rehab followed by only HM-1 treatments, HM-1 performed at ($\leq 10\%B$) & ($A+B \leq 10\%$)		309.9 (32%)	319.2 (30%)	318.2 (47%)	336 (44%)
Each rehab followed by two HM-1 treatments, HM-1 performed at ($\leq 10\%B$) & ($A+B > 10\%$)	A+B $\geq 10\%$ $x \leq 10\%$				
Rehab followed by only HM-1 treatments, HM-1 performed at ($\leq 10\%B$) & ($A+B > 10\%$)		337 (26%)	337 (26%)	368.1 (39%)	368.1 (39%)
Each rehab followed by two HM-1 treatments, HM-1 performed at (> 25%B)	X>25%	307.8 (33%)	398.4 (13%)	315.4 (31%)	477.8 (21%)
Rehab followed by only HM-1 treatments, HM-1 performed at (> 25%B)		307.8 (33%)	328.7 (28%)	315.4 (31%)	359.8 (40%)

Results from LCC calculations shown in Table 61 for chip seals with conventional binders (Chip Seal-AC) led to the following observations when compared with the subscenario of only rehabilitation with no maintenance treatments (first row in the table):

- When preventive actions are performed at less than 10 percent Alligator B cracking, a minimum saving of 26 percent is achieved over a 20-year analysis period.
- When preventive actions are performed at less than 10 percent Alligator B cracking, a minimum saving of 21 percent is achieved over a 35-year analysis period.
- Asphalt chip seals applied even at >25% Alligator B cracking result in at least a 13 percent saving in LCC versus rehabilitation without subsequent preservation treatment.

In general, regardless of when the preventive maintenance action is performed, it is more cost-effective to apply preventive maintenance actions to pavements than not to apply treatments. This is true for both dense-graded asphalt overlays and conventional chip seals. The cost savings from the 35-year analysis are higher than those from the 20-year analysis. The range of values and the trends in these results indicate the order of magnitude and the trend of likely life-cycle cost savings. This appears reasonable, based on the limited data available.

7.6.2 LCCA Objective 2: Should Pavement Preservation Be Applied at an Earlier or a Later Stage of Cracking?

Costs shown in Table 62, where a preservation treatment (HM-1 dense-graded asphalt concrete overlay) is applied at either A+B and B cracking less than or equal to 10 percent, A+B greater than or equal to 10 percent and B cracking less than or equal to 10 percent, and B cracking greater than 25 percent, after rehabilitation was done at Alligator B cracking greater than 25 percent, resulted in the following observations:

- Trends from the limited data available suggest that waiting until a later stage of cracking results in life-cycle costs of up to 16 percent higher (for 20-year analysis) than if treatments are placed at an earlier stage of cracking; some cases did not show any higher cost.
- In the 35-year analysis, delaying treatment until later-stage cracking increases life-cycle costs up to 12 percent.

**Table 62: LCC of Preventive Treatment at Early vs. Later Stage of Cracking
(Rehabilitation at >25% Alligator B Cracking)—Dense-Graded Overlay**

Scenario Set No.2 - Rehabilitation Treated at >25% Alligator B Crack	Existing B Crack Pre-Constructio ⁿ	HM-1 Treatment = DGAC overlay			
		LCC over 20 Years in \$1000/mi/ln (Cost increase from main't at very low cracking)		LCC over 35 Years in \$1000/mi/ln (Cost increase from main't at very low cracking)	
		Low AADTT	High AADTT	Low AADTT	High AADTT
Each rehab followed by two HM-1 treatments, HM-1 performed at ($\leq 10\%B$) & ($A+B \leq 10\%$)	A+B<10% x \leq 10%		333.3		426.1
Rehab followed by only HM-1 treatments, HM-1 performed at ($\leq 10\%B$) & ($A+B \leq 10\%$)			333.3		369.6
Each rehab followed by two HM-1 treatments, HM-1 performed at ($\leq 10\%B$) & ($A+B > 10\%$)	A+B \geq 10% x \leq 10%	332	333.8 (0%)	425.4	447.7 (5%)
Rehab followed by only HM-1 treatments, HM-1 performed at ($\leq 10\%B$) & ($A+B > 10\%$)		332	333.8 (0%)	360.2	369.6 (0%)
Each rehab followed by two HM-1 treatments, HM-1 performed at (> 25%B)	X>25%		396.5 (16%)		484.3 (12%)
Rehab followed by only HM-1 treatments, HM-1 performed at (> 25%B)			343.7 (3%)		387.7 (5%)

**Table 63: LCC of Preventive Treatment at Early vs. Later Stage of Cracking
(Rehabilitation at >25% Alligator B Cracking)—Chip Seal-AC**

Scenario Set No.2 - Rehabilitation Treated at >25% Alligator B Crack	Existing B Crack Pre-Constructio ⁿ	HM-1 Treatment = AC Chipseal			
		LCC over 20 Years in \$1000/mi/ln (Cost increase from main't at very low cracking)		LCC over 35 Years in \$1000/mi/ln (Cost increase from main't at very low cracking)	
		Low AADTT	High AADTT	Low AADTT	High AADTT
Each rehab followed by two HM-1 treatments, HM-1 performed at ($\leq 10\%B$) & ($A+B \leq 10\%$)	A+B<10% x \leq 10%	309.9			
Rehab followed by only HM-1 treatments, HM-1 performed at ($\leq 10\%B$) & ($A+B \leq 10\%$)		309.9	319.2	318.2	336
Each rehab followed by two HM-1 treatments, HM-1 performed at ($\leq 10\%B$) & ($A+B > 10\%$)	A+B \geq 10% x \leq 10%				
Rehab followed by only HM-1 treatments, HM-1 performed at ($\leq 10\%B$) & ($A+B > 10\%$)		337 (8%)	337 (5%)	368.1 (14%)	368.1 (9%)
Each rehab followed by two HM-1 treatments, HM-1 performed at (> 25%B)	X>25%	307.8 (-1%)	398.4	315.4	477.8
Rehab followed by only HM-1 treatments, HM-1 performed at (> 25%B)		307.8 (-1%)	328.7 (3%)	315.4 (-1%)	359.8 (7%)

Based on calculated costs in Table 63 for chip seals with conventional binders, the following was observed:

- Life-cycle costs can increase up to 14 percent by waiting to apply chip seals beyond 10 percent of the wheelpath with A + B cracking.
- Unexpected results, showing nominally unchanged life-cycle costs when chip seals are applied when Alligator B cracking exceeds 25 percent (versus applying the seals at a lower stage of cracking), are attributed to the limited data available for analysis.

Values and trends in the LCCA for dense-graded AC are expected to better represent the effects of applying treatments earlier, when cracking levels are lower. Results from the LCCA for chip seals indicate the limitations of the data available.

7.6.3 LCCA Objective 3: Comparison of LCC of Different Combinations of Pavement Treatments

The costs in Table 64 enable comparison of two alternative application sequences of preservation treatments (dense-graded asphalt concrete overlay), where (1) rehabilitation is followed by two HM-1 treatments and then another rehabilitation or (2) rehabilitation is followed successively only by HM-1 treatments. Results led to the following observations:

- In the 20-year analysis, life-cycle costs are the same, except for pavements on which the HM-1 overlays are applied at greater than 25 percent Alligator B cracking, where successive application of HM-1 results in a 13 percent reduction in LCC.
- In the 35-year analysis, LCC savings range from 13 to 20 percent when HM-1 treatments are applied successively.

**Table 64: LCC of Two HM-1 vs. Unlimited HM-1 Preventive Actions
(Rehabilitation at >25% Alligator B Cracking)—Dense-Graded Overlay**

Scenario Set No.2 - Rehabilitation Treated at >25% Alligator B Crack	Existing B Crack Pre-Constructio ⁿ	HM-1 Treatment = DGAC overlay			
		LCC over 20 Years in \$1000/mi/ln (Cost decrease from two HM-1 to unlimited HM-1 after Rehab)		LCC over 35 Years in \$1000/mi/ln (Cost decrease from two HM-1 to unlimited HM-1 after Rehab)	
		Low AADTT	High AADTT	Low AADTT	High AADTT
Each rehab followed by two HM-1 treatments, HM-1 performed at ($\leq 10\%B$) & ($A+B \leq 10\%$)	A+B<10% x \leq 10%		333.3		426.1
Rehab followed by only HM-1 treatments, HM-1 performed at ($\leq 10\%B$) & ($A+B \leq 10\%$)			333.3 (0%)		369.6 (13%)
Each rehab followed by two HM-1 treatments, HM-1 performed at ($\leq 10\%B$) & ($A+B > 10\%$)	A+B \geq 10% x \leq 10%	332	333.8	425.4	447.7
Rehab followed by only HM-1 treatments, HM-1 performed at ($\leq 10\%B$) & ($A+B > 10\%$)		332 (0%)	333.8 (0%)	360.2 (15%)	369.6 (17%)
Each rehab followed by two HM-1 treatments, HM-1 performed at (> 25%B)	X>25%		396.5		484.3
Rehab followed by only HM-1 treatments, HM-1 performed at (> 25%B)			343.7 (13%)		387.7 (20%)

**Table 65: LCC of Two HM-1 vs. Unlimited HM-1 Preventive Actions
(Rehabilitation at >25% Alligator B Cracking)—Chip Seal**

Scenario Set No.2 - Rehabilitation Treated at >25% Alligator B Crack	Existing B Crack Pre-Constructio ⁿ	HM-1 Treatment = AC Chipseal			
		LCC over 20 Years in \$1000/mi/ln (Cost decrease from two HM-1 to unlimited HM-1 after Rehab)		LCC over 35 Years in \$1000/mi/ln (Cost decrease from two HM-1 to unlimited HM-1 after Rehab)	
		Low AADTT	High AADTT	Low AADTT	High AADTT
Each rehab followed by two HM-1 treatments, HM-1 performed at ($\leq 10\%B$) & ($A+B \leq 10\%$)	A+B<10% x \leq 10%	309.9			
Rehab followed by only HM-1 treatments, HM-1 performed at ($\leq 10\%B$) & ($A+B \leq 10\%$)		309.9 (0%)	319.2	318.2	336
Each rehab followed by two HM-1 treatments, HM-1 performed at ($\leq 10\%B$) & ($A+B > 10\%$)	A+B \geq 10% x \leq 10%				
Rehab followed by only HM-1 treatments, HM-1 performed at ($\leq 10\%B$) & ($A+B > 10\%$)		337	337	368.1	368.1
Each rehab followed by two HM-1 treatments, HM-1 performed at (> 25%B)	X>25%	307.8	398.4	315.4	477.8
Rehab followed by only HM-1 treatments, HM-1 performed at (> 25%B)		307.8 (0%)	328.7 (17%)	315.4 (0%)	359.8 (25%)

Based on costs shown in Table 65, in the case of an chip seals with conventional binders, the following was observed:

- Very little data is available to identify trends.
- Life-cycle costs may be lower (possibly as much as 25 percent) if chip seals are applied successively as opposed to placing a rehabilitation treatment after two preservation treatments.

Some of the differences in results observed from the 20- and 35-year analysis periods are due to the fact that the 20-year analysis duration does not reflect the cost of the second rehabilitation (based on the expected life of each treatment used in this analysis, shown in Table 46 to Table 52). Comparing different combinations of preservation treatments was severely hampered by limitations in available data. Substantially more projects with maintenance and rehabilitation histories and reasonably matched pavement performance data are needed to draw more meaningful conclusions.

8 SUMMARY AND PRELIMINARY CONCLUSIONS

The purpose of this project is to develop performance estimates for pavement preservation treatments on flexible pavements. This project is part of a larger UCPRC project (SPE 3.2.5) that has three main objectives, with deliverables as follows:

- Track pavement preservation projects through performance databases.
 - List of pavement preservation treatments
 - Database of projects, pavement performance data, traffic, climate, and cost
- Estimate pavement performance for various strategies and application times.
 - Pavement performance histories for each section
 - Statistical analysis to identify performance probabilities
- Analyze life-cycle costs; recommend optimum timing and strategy selection (for those treatments for which sufficient performance data is available).
 - Calculated life-cycle costs
 - Analysis of timing and relative performance

The final deliverable is documentation that shows results of the research. This technical memorandum summarizes the results of the project, which are most likely the best ones that can be obtained from the current Caltrans PMS database. Several gaps that exist in the database, which are summarized below, have made all the conclusions presented in this report “preliminary” in nature. Changes are currently underway to address these gaps in an updated PMS.

8.1 Tracking Pavement Preservation Projects

The UCPRC worked with HQ Division of Maintenance and contacted all Districts to identify projects and retrieve project histories for treatments within the HM-1, CapM, and Rehabilitation programs. The problem of finding maintenance and rehabilitation histories (i.e., what was done and when it was done) to identify pavement preservation treatments applied or not applied still has not been solved despite significant staff effort by Caltrans Maintenance to help find this information. Starting with 2,564 projects, over two-thirds had to be omitted. Over 900 were not old enough to have sufficient performance history (treatment performance in 2003 or later). A weighting algorithm developed by UCPRC to overcome or mitigate the dynamic segmentation of the network in the PMS database was used to extract performance data to try to link it with construction histories. Over 500 projects (beyond the 900 mentioned above) were omitted because their performance history did not match construction information. Over 300 projects were

omitted due to duplicate construction entries or no completion data. As-built information was not available, including the thickness of overlays, which must be a significant variable. Project funding programs (HM-1, CapM, and Rehabilitation) were used as surrogates for overlay thickness.

The final database includes 718 projects. Most (82 percent) of the projects are located in three Caltrans districts (2, 4, and 8). Nearly two-thirds of the treatments in the database are conventional dense-graded asphalt overlays. The lack of construction histories for other treatments limits what can be concluded about their performance and cost-effectiveness. The resulting database is the most complete available but remains a limited and unbalanced representation of pavement treatments and performance histories.

It can be concluded from the exercise of putting together this database that significant changes are needed in both pavement condition data collection and as-built data collection, as well as in the management of Caltrans pavement-related databases, if Caltrans is going to be able to do a better job of determining pavement performance and life-cycle costs than was possible in this study. Recommendations for changes in practice are included at the end of this chapter.

8.2 Estimated Pavement Performance

Performance estimates were developed for sections where construction histories could be found, and they reasonably matched expected pavement performance trends. For the sections included in the analysis, pavement preservation treatments were applied at varying levels of cracking. The average (mean) value of existing Alligator B cracking is 17 percent when placing HM-1 asphalt overlays, 16 percent for rehabilitation overlays, and 12 percent for CapM. This suggests that pavement preservation using thin overlays was being applied at high levels of cracking where CapM or rehabilitation may be more suitable. This also indicates that the application of HM-1 asphalt overlays during the period 1988 to 2003 would not generally be considered pavement preservation, because a relatively high level of cracking was present when many overlays were placed.

The average value of existing Alligator B cracking was 10 percent when placing chip seals with conventional asphalt, 13 percent for asphalt rubber chip seals, and 15 percent for polymer-modified chip seals. This suggests that rubber and polymer-modified chip seals were placed on pavements with more cracking. Comparatively few sections in the database deal with chip seals that use rubber and polymer-modified binders. More sections are needed for inferences that have greater reliability.

After statistical evaluation of factors expected to affect pavement performance, it was decided to stratify expected pavement life (number of years until 10 percent cracking and number of years until 25 percent cracking), by existing cracking at the time of treatment application (less than 10 percent cracking, 10 percent to 25 percent cracking, and more than 25 percent cracking), rainfall (wet/dry), and traffic (high/low). A statistical method used for estimating failure probability distributions was used to calculate a median value of expected life for those preservation treatments with sufficient valid sections. Most treatments have inadequate performance histories to produce a substantial number of median values. For those with values, insufficient data prevented clear, consistent, and reasonable trends for some cases.

The median number of years to 10 percent Alligator B cracking for HM-1 overlays ranged from three to eight years, with four and five years occurring most frequently (for all traffic and rainfall conditions) whether existing Alligator B cracking at the time of treatment is less than 10 percent or more than 25 percent. Slight but reasonable trends were found, such as an association between high traffic and shorter pavement life. However, unexpected trends also appear, such as wet conditions being associated with longer pavement life. These are likely due to imbalances in the database.

Chip seals (based on a pooled dataset for conventional and modified binders), when applied where Alligator B cracking is low, last at least five years (median) until 10 percent Alligator B cracking occurs. As expected, high traffic substantially reduces service life. The effect of rainfall on chip seal performance is not discernible.

8.3 Life-Cycle Cost Analysis

Analysis of life-cycle costs, based on the limited and biased database, enables order of magnitude estimates and suggests trends. A more complete database of project maintenance and rehabilitation histories is needed to obtain more precise estimates.

The LCCA focused on answering the following three questions:

- Is it more beneficial to apply pavement preservation than to perform no maintenance?
- Should pavement preservation be applied at an earlier or a later stage of cracking?
- How do life-cycle costs compare for different combinations of preservation treatment?

Answers to these questions were drawn only from data for dense-grade asphalt overlays and chip seals with conventional binders because of lack of data for other treatments. The LCCA was performed based on analysis periods of 20 and 35 years and produced similar trends for both periods.

Expected performance life (drawn from statistical analysis of observed performance histories) and inputs from the Caltrans *RealCost* manual were used to calculate net present value. Scenarios for LCCA compared projected performance of rehabilitation projects followed by (1) no maintenance until future rehabilitation, (2) only two HM-1 treatments until future rehabilitation, and (3) only HM-1 treatments without any future rehabilitation. These scenarios were evaluated for varying existing alligator cracking and low vs. high traffic where sufficient data were available.

Results show savings in life-cycle costs from applying pavement preservation. The trends and magnitude of savings are similar for both asphalt overlays and chip seals. Application of pavement preservation between rehabilitations shows life-cycle costs 13 percent to 47 percent lower than rehabilitation without preservation. This range is seen as indicating the order of magnitude and trend of life-cycle cost savings. This level of detail is the best that appears reasonable, based on the limited data available.

Where preservation treatments are applied, LCCA was used to estimate cost savings from applying treatments (thin overlay or chip seal) at an earlier or a later stage of cracking. For cases where sufficient data are available, waiting until later stages of cracking results in life-cycle costs up to 14 percent higher than if treatments are placed at an earlier stage of cracking. Some cases did not show any higher cost. As with other conclusions, this may be due to the limited database.

Comparing various combinations of preservation treatments was severely hampered by the data limitations mentioned above. Life-cycle costs were estimated for two cases. In the first case, rehabilitation is followed by two treatments and another rehabilitation. In the second case, rehabilitation is followed only by successive preservation treatments throughout the analysis period. For preservation with only thin overlays, the second case (all preservation, no future rehabilitation) showed costs savings ranging from zero up to 20 percent. Where only chip seals were used, the second case cost savings ranged from zero up to percent to 25 percent.

Substantially more projects with maintenance and construction histories and reasonably matched pavement performance trends are needed to make more-meaningful and higher-confidence conclusions about combinations of preservation treatments, timing of applying treatments, and quantitative benefits of pavement preservation.

8.4 Recommendations

8.3.1 Pavement Preservation Practice

The estimates of pavement performance and life-cycle cost analysis based on the very limited data that could be gathered and analyzed in this study provide some indication that life-cycle cost savings can be obtained by use of the following pavement preservation practice:

- Use pavement preservation treatments, as opposed to using rehabilitation alone.
- Place pavement preservation treatments at lower levels of cracking than was the practice from 1988 to 2003, with the comparison in this study being made between treatment at less than or equal to 10 percent Alligator B cracking versus more than 25 percent Alligator B cracking.

8.3.2 Caltrans PMS Data

A number of lessons were learned, or reemphasized from previous studies, throughout the pavement preservation performance and life-cycle cost analysis. Subsequently, the following recommendations are made to improve future studies of this type:

- Since one of the purposes of a PMS is to develop performance models relating maintenance and rehabilitation to changes in the condition of the pavement, it is essential that additional data be included in the PMS database that is not currently included. Such data consists of underlying structure of the pavement, quality control records, and as-built information, including (at a minimum) material type, thickness, and actual date of placement on the road. Project construction histories were not available for maintenance performed directly by Caltrans forces, which means that pavement distresses appear to be reduced in the condition survey data without any explainable treatment in the construction information available. Inclusion of maintenance histories, including treatment type, location, and date, will greatly increase the ability to connect pavement condition to the work performed. It is also important that traffic data be tied to PMS data through relational database rules. Linking of traffic data to other data must currently be done by hand via spreadsheets, and traffic data must typically be downloaded by hand from PDF files.
- Improve quality of the pavement condition data by
 - Conducting pavement survey on a fixed segmentation rather than current dynamic segments, which will help in creating time histories necessary for developing pavement performance models, and in identifying missing data from year to year and discrepancies in data from year to year (such as pavement that improves in condition without any treatment), and

- Wherever possible, performing the pavement condition survey using measurements of distress condition as opposed to identifying it as a binary variables (0 if present, 1 if not), which do not have clear criteria and are evaluated visually.
- Wherever possible, take a more systematic approach, such as using an automated device rather than the currently used “eyeball” visual inspection. Improved accuracy on pavement condition data will help in extracting more-realistic performance estimates.

8.3.3 Pavement Preservation Test Sections

The *Pavement Preservation Studies Technical Advisory Guide* (PPSTAG) (8) guidelines were developed for Caltrans by the UCPRC for use on controlled experiments that compared pavement preservation treatments both to each other and to control sections (with no pavement preservation). Use of these guidelines is recommended to help each Caltrans District in future efforts to set up field evaluation of control and test sections. These experiments can provide more-detailed information than PMS data alone, and can be used in conjunction with improvements in the PMS to perform more-accurate and more-comprehensive analysis of pavement preservation life-cycle cost analysis than were possible with the data available for the study presented in this technical memorandum.

8.3.4 Framework for Future LCCA Evaluations of Cost-Effectiveness of Pavement Treatments

It is recommended that the framework for performing life-cycle cost analysis evaluations of cost-effectiveness of pavement treatments presented in this memorandum be used in the future by Caltrans. Once the major gaps in the data identified in this project are addressed through improvements to the Caltrans PMS—primarily consistent condition survey segmentation and better tracking of construction histories and overlay thicknesses—this project should be repeated to draw more definitive conclusions.

9. REFERENCES

1. University of California Pavement Research Center. Work Plan for “Performance Review of Pavement Preservation Treatments.” September 1, 2006.
2. Lea, J., and Harvey, J. T. August 2002 (Revision December 2004). “Data Mining of the Caltrans Pavement Management System (PMS) Database.” Draft report prepared for the California Department of Transportation. Pavement Research Center, Institute of Transportation Studies, University of California, Berkeley. UCPRC-RR-2002-04.
3. Kannekanti, V., Lee, C., Popescu, L., Harvey, J., and Nokes, W. November 2007. “Pavement Performance Data Extraction from Caltrans’ PMS.” UCPRC-TM-2007-06.
4. Lu, Q., Harvey, J., Lea, J., Quinley, R., Redo, D., and Avis, J. June 2002. “Truck Traffic Analysis Using Weigh-in-Motion (WIM) Data in California.” University of California Pavement Research Center, Institute of Transportation Studies, University of California, Berkeley. UCPRC-RR-2002-01.
5. Madanat, S., Nakat, Z., and Sathaye, N. October 2005. “Development of Empirical-Mechanistic Pavement Performance Models Using Data from the Washington State PMS Database.” Davis and Berkeley, California. UC Pavement Research Center. UCPRC-RR-2005-05.
6. Madanat, S., and Nakat, Z. “Development of an Empirical-Mechanistic Model of Overlay Crack Progression Using Data from the Washington State PMS Database,” page 49. Davis and Berkeley, California. UC Pavement Research Center. (In progress.)
7. See Interim *RealCost* User Manual updated April 2007 from Caltrans web site: www.dot.ca.gov/hq/esc/Translab/OPD/LCCA_Manual_MASTER_4_1_07.pdf. Accessed August 28, 2007.
8. Jones, D January 2007. “Pavement Preservation Studies Technical Advisory Guide.” Guideline prepared for the California Department of Transportation, Division of Research and Innovation, Office of Roadway Research, by the University of California Pavement Research Center, UC Davis and Berkeley. UCPRC-GL-2005-01.

APPENDIX A: GLOSSARY

AADTT: Annual Average Daily Truck Traffic.

ACOL: Asphalt Concrete Overlay—placing layers of asphalt and inner membranes over an existing roadway.

Alligator (fatigue) cracking: Cracks in asphalt that are caused by repeated traffic loadings. The cracks indicate fatigue failure of the asphalt layer. When cracking is characterized by interconnected cracks, the cracking pattern resembles that of an alligator's skin.

Alligator A—A single crack or two parallel longitudinal cracks in the wheelpath; cracks are not spalled or sealed; rutting or pumping is not evident.

Alligator B—An area of interconnected cracks in the wheelpath forming a complete pattern; cracks may be slightly spalled; cracks may be sealed; rutting or pumping may exist.

CapM: Capital Preventive Maintenance: Use of heavy maintenance treatments such as intermediate thickness asphalt blankets to provide five to seven years of additional pavement life. CapM projects are thinner than Rehabilitation projects and add structural strength to the pavement.

HM-1: The highway program that funds routine and major maintenance on the state highway network. The HM-1 program is preventive pavement repair work intended to preserve the system, retard future deterioration, and prolong the service life of the pavement.

IRI—International Roughness Index: A standardized method of measuring the roughness of the pavement surface, expressed in inches per mile or centimeters per kilometer, developed by the World Bank.

Type of pavement treatments:

- ACOL-DG: Dense-graded Asphalt Concrete Overlay
- ACOL-OG: Open-graded Asphalt Concrete Overlay
- ACOL-RAC: Rubberized Asphalt Concrete Overlay—a mixture of asphalt concrete containing rubber “crumbs” and synthetic binders
- ACOL-RACO: Rubberized Open-graded Asphalt Concrete Overlay

- ChipSeal-AC: Asphalt Concrete Chip Seal—a surface treatment in which the pavement is sprayed with asphalt and then immediately covered with aggregate and rolled with a pneumatic tire roller
- ChipSeal-AR: Rubberized Asphalt Concrete Chip Seal
- ChipSeal-PMA: Polymer Modified Asphalt Concrete Chip Seal
- ChipSeal-PME: Polymer Modified Emulsion Asphalt Concrete Chip Seal
- CrackSeal: Sealant applied to the crack lines on a pavement surface
- DigOut: Localized portion of the distressed pavement is removed, then patched with asphalt concrete
- SlurrySeal: A petroleum-based emulsion sealing coat (with embedded fine aggregates) applied to the pavement surface

APPENDIX B: DEFINITION OF DATA CENSORING

Summarized and paraphrased from Leemis, L. M. *Reliability: Probabilistic Models and Statistical Methods*. Prentice-Hall, 1995.

A data set is called *complete* when all failure times are known and *censored* if there are one or more censored observations. A data set is called censored if there are one or more censored observations. There are categories of censored data: *right censored*, *left censored*, and *interval censored*. Right censoring occurs in long-lived pavements when one or more pavement sections do not have a final failure observation. This typically occurs when data is being analyzed before all of the sections have failed (this is a major limitation of the FHWA LTPP set of pavements, for example).

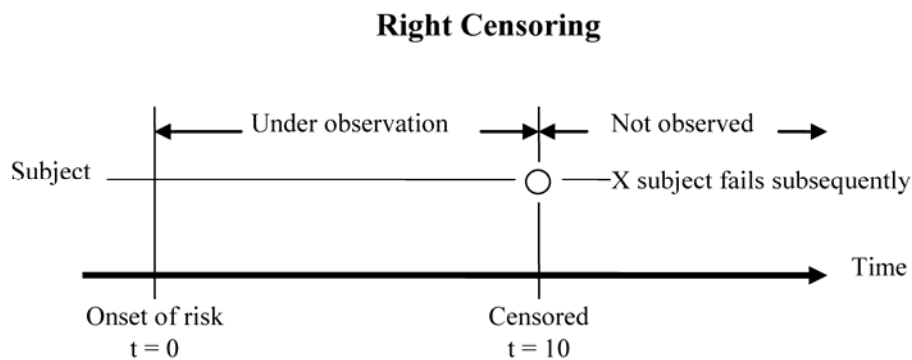

Left censoring occurs when data collection began after the pavements were constructed and failure occurred prior to the first observation, when the time of construction is unknown, or when condition survey procedures were changed and new variables were collected only for a certain, usually later, period of time.

Left Censoring

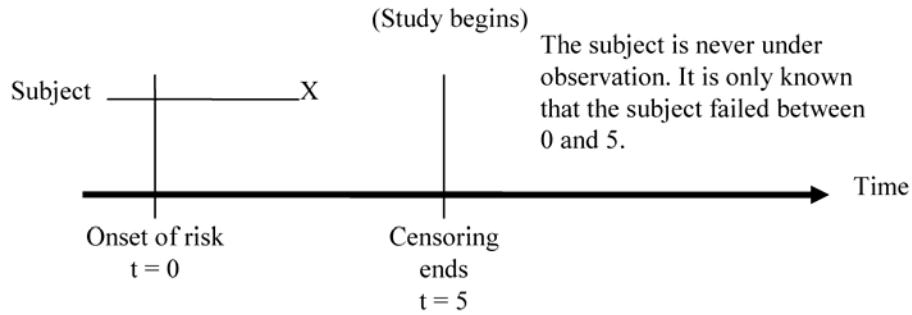

Interval censoring occurs when the pavement is checked periodically for failure, with gaps in the normal data collection schedule, for example if an annual condition survey is not performed for several years. The information available for the pavement section indicates that it failed sometime during the interval prior to when failure was detected.

Interval Censoring

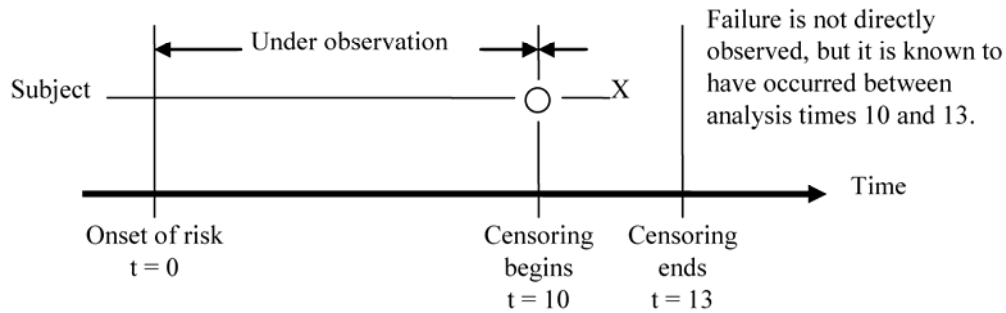

APPENDIX C: EXAMPLE CALCULATION OF PROBABILITY OF FAILURE DISTRIBUTION FOR FIGURE 8.

Example: for HM-1 ACOL-DG performance under the following conditions:

(exABC<10%, Wet, LowAADTT)

Failure definition is set at 10% Alligator A crack.

Year (j)	n _j	d _j	Kaplan-Meier Estimate S(t)	Failure Rate (CDF) F(t) = 1-S(t)	Failure Rate (PDF) f(t) = F(t)-F(t-1)
0	0	0	1.000	0.000	
1	77	2	0.974	0.026	0.026
2	75	5	0.909	0.091	0.065
3	62	3	0.865	0.135	0.044
4	45	5	0.769	0.231	0.096
5	29	3	0.689	0.311	0.080
6	23	4	0.570	0.430	0.120
7	10	1	0.513	0.487	0.057
8	3	1	0.342	0.658	0.171
9	2	2	0.000	1.000	0.342
10	2	0			
11	2	0			
12	2	0			
13	2	0			
14	2	0			
15	2	0			
16	2	0			
17	2	0			
18	2	0			
19	2	0			
20	2	0			

Where n and d are defined by Equation 2 in Section 6.1. $\hat{S}(t)$ is the Kaplan-Meier survival rate estimator.

$$\hat{S}(t) = \prod_{j=1}^k \left(\frac{n_j - d_j}{n_j} \right) \quad \text{For } t_{j-1} \leq t < t_j$$

where, n_j = number of pavements not failed and that are still being observed (termed “at risk”) before t_j and

d_j = number of pavements failed in the time interval $t_{j-1} \leq t < t_j$.

The failure probability of an item before t is then $\Pr(x < T) = 1 - \hat{S}(t)$