

UC Davis

UC Davis Previously Published Works

Title

Antimicrobial peptides: agents of border protection for companion animals

Permalink

<https://escholarship.org/uc/item/8978458f>

Journal

Veterinary Dermatology, 23(3)

ISSN

0959-4493

Authors

Leonard, Brian C
Affolter, Verena K
Bevins, Charles L

Publication Date

2012-06-01

DOI

10.1111/j.1365-3164.2012.01037.x

Peer reviewed

Antimicrobial peptides: agents of border protection for companion animals

Brian C. Leonard*, Verena K. Affoltert and Charles L. Bevins*

*Department of Microbiology and Immunology, UC Davis School of Medicine, Davis, CA 95616, USA

†Department of Veterinary Pathology, Microbiology and Immunology, UC Davis School of Veterinary Medicine, Davis, CA 95616, USA

Correspondence: Charles L. Bevins, Department of Microbiology and Immunology, UC Davis School of Medicine, Davis, CA 95616, USA.

E-mail: clbevins@ucdavis.edu

Over the past 20 years, there have been significant inroads into understanding the roles of antimicrobial peptides in homeostatic functions and their involvement in disease pathogenesis. In addition to direct antimicrobial activity, these peptides participate in many cellular functions, including chemotaxis, wound healing and even determination of canine coat colour. Various biological and genetic approaches have helped to elucidate the role of antimicrobial peptides with respect to innate immunity and host defense.

Associations of antimicrobial peptides with various skin diseases, including psoriasis, rosacea and atopic dermatitis, have been documented in humans. In the longer term, therapeutic modulation of antimicrobial peptide expression may provide effective new treatments for disease.

This review highlights current knowledge about antimicrobial peptides of the skin and circulating leukocytes, with particular focus on relevance to physiology and disease in companion animals.

Introduction

Antimicrobial peptides (AMPs) are naturally occurring antimicrobials found throughout nature. In mammals, AMPs are expressed by both epithelial cells and phagocytic leukocytes, and they possess broad-spectrum antimicrobial activity against bacteria, fungi and viruses.¹ In addition, AMPs can promote chemotaxis, wound healing and, interestingly, determination of coat colour in dogs (Figure 1).^{2–4} Antimicrobial peptides have been identified and described in all mammals studied,⁵ including companion animals.^{4,6,7} The two major subfamilies of AMPs in mammals are cathelicidins and defensins,¹ which exhibit similar physical properties and many overlapping activities (Figure 2).

Mammalian skin is generally thought of as a thin lining that separates the host from the external world. Despite constant confrontation with pathogens, the incidence of skin infections remains relatively low. The epidermis provides a physical barrier to microbial invasion and prevents favourable niches for pathogens. In the event that this physical barrier is breached, a co-ordinated innate immune response, involving macrophages and neutrophils, is activated to eliminate the invaders.⁸ However, this view of innate immunity is incomplete. Recent evidence shows that the epidermis is much more than just a physi-

cal barrier.⁸ Indeed, epidermal keratinocytes are equipped with pathogen recognition receptors and can detect and respond to potential invaders.⁸ This response helps to initiate a co-ordinated inflammatory response, which includes recruitment of leukocytes. Another important element of this defensive response is the induction of AMPs by keratinocytes.⁵ This review highlights the current knowledge of AMPs in dogs, cats and humans, with particular relevance to skin biology and disease.

Repertoire of AMPs

Defensins

Defensins are small, cationic peptides that are expressed by certain phagocytic leukocytes and epithelial cells. These peptides possess broad-spectrum antimicrobial activity (Figure 2).⁵ The defensins are categorized into three subfamilies, α , β and θ , based on their disulfide bonding array and primary amino acid sequence.⁵ Evolutionarily speaking, the β -defensins are the oldest of the defensins, tracing their ancestry back to the horseshoe crabs.⁹ The host genomic repertoire of defensins varies greatly between species, in both number of defensins encoded and sequence diversity.¹⁰ The α -defensins have been found in primates, glires and horses, but not in dogs,^{10,11} whereas the β -defensins have been documented in all mammals and some lower order species as well.⁵ The θ -defensins are unique in that they are encoded in the genomes of humans and nonhuman primates, although a functional gene product has only been found in nonhuman primates.¹²

A comparative genome analysis of the dog has identified 43 β -defensin genes and pseudogenes. Much of the gene nomenclature has been modelled after putative human orthologues.¹⁰ Canine β -defensins are arranged in

Accepted 10 January 2012

Sources of Funding: Research in the Bevins laboratory has been supported by the NIH (AI032738, AI50843 and AI076246). B.C.L. received support from NIH T32A160555 and T32RR021312, as well as the UC Davis School of Veterinary Medicine Veterinary Scientist Training Program.

Conflicts of Interest: No conflicts of interest have been declared.

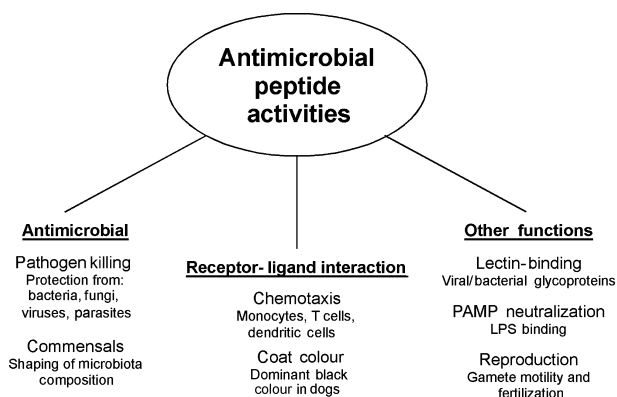

Figure 1. Antimicrobial peptides serve as peptide effectors of innate immunity, and they participate in the co-ordination of inflammatory responses. Abbreviations: LPS, lipopolysaccharide; and PAMP, pathogen-associated molecular patterns.

four gene clusters that correspond to those in rats, mice and humans.¹⁰ The best-characterized β -defensin cluster in humans is encoded on chromosome 8p23.1, which is syntenic with the β -defensin cluster on chromosome 16 of dogs (Figure 3).¹⁰ The first canine defensin gene identified was named canine β -defensin-1 (*CBD1*), and appears to encode the orthologue of BD1 in rodents and humans. The remaining canine defensin genes are numbered *CBD102–CBD142* (to correspond roughly to their human counterparts); two additional defensin genes

are referred to as canine sperm-associated antigen (*SPAG11c* and *SPAG11e*).¹⁰ The study by Patil *et al.*¹⁰ clearly defines and names all of the defensins in the canine genome. Owing to the already complex nomenclature in the defensin field, we encourage fellow investigators to adopt this scheme as a consistent method of labelling canine defensins to reduce ambiguity and ease the interpretation of data between studies.

Cathelicidins

Cathelicidins are AMPs that also possess broad-spectrum activity, yet they exhibit great diversity in both sequence and structure (Figure 2).¹³ Like defensins, the cathelicidin precursor has three domains: a signal sequence, a propeptide domain and a mature peptide at the C-terminus.¹⁴ However, the unifying feature of cathelicidins is not the sequence of the mature peptide, but the propeptide domain, a region with sequence similarity to the protease inhibitor, cathelin.¹³ The sequence of this propeptide domain is highly conserved across diverse species.^{14,15} In contrast, the mature peptide sequence varies widely between species and can be classified into the following four subfamilies: linear α -helical; proline- and arginine-rich; tryptophan-rich; or disulphide bond-containing peptides.¹⁴ In addition to sequence diversity of the mature peptide, there is considerable variability in the number of cathelicidins encoded by genomes of various species.¹⁵ Humans (LL-37), mice (CRAMP), dogs (K9CATH) and cats (feCath) express a single cathelicidin,

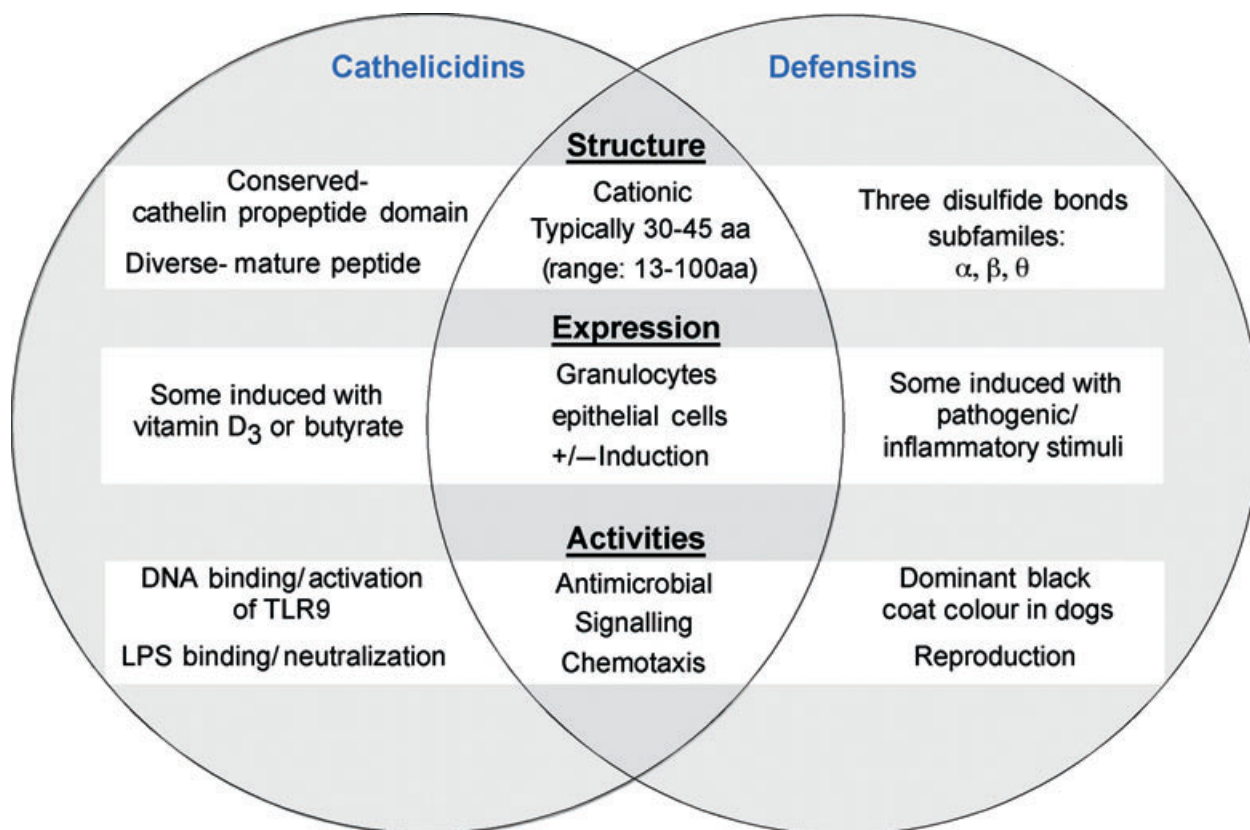

Figure 2. Venn diagram showing the similarities and differences between the two major subgroups of antimicrobial peptides, cathelicidins and defensins. Overlap indicates similar peptide characteristics, whereas the nonoverlapping regions are specific differences between the subgroups. Abbreviations: LPS, lipopolysaccharide; and TLR9, Toll-like receptor 9.

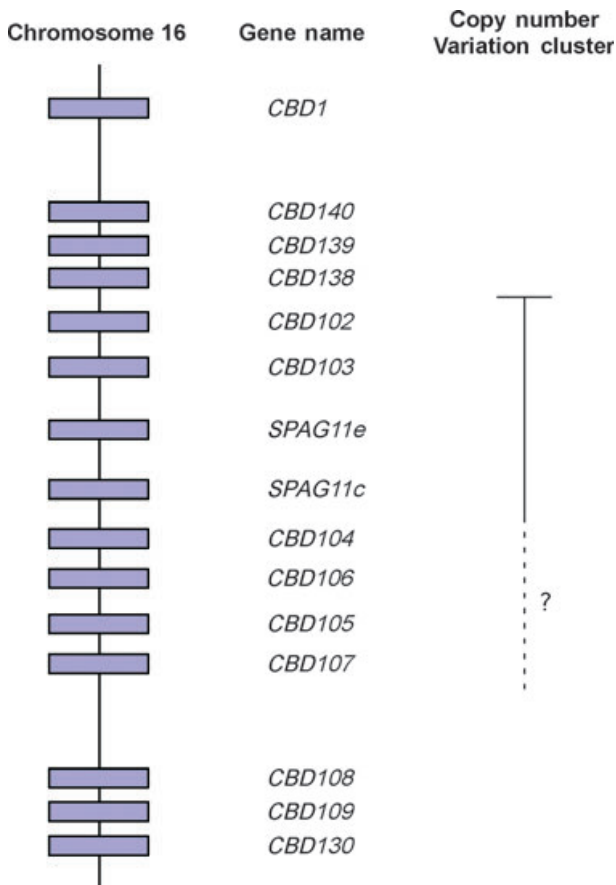

Figure 3. Defensin gene cluster on canine chromosome 16. Canine chromosome 16 encodes a cluster of β -defensin genes. The genetic organization of this cluster is very similar to the orthologous defensin cluster on human chromosome 8p. Within the defensin cluster, some β -defensin genes exhibit gene copy-number polymorphism, beginning with *CBD102* (indicated by a continuous line). The distal end of the cluster has yet to be defined (indicated by a dotted line). Figure adapted from Patil *et al.*¹⁰

whereas horses, pigs, cows and goats express multiple cathelicidins.^{7,15,16}

Expression patterns of AMPs

Depending on the particular peptide in question, the expression of AMPs is either constitutive or inducible by various stimuli, including inflammation and the presence of pathogens.^{5,17}

Defensins

The β -defensins expressed in human skin include human β -defensin 1 (hBD-1),¹⁸ hBD-2¹⁹ and hBD-3.²⁰ Canine skin highly expresses β -defensins CBD1 and CBD103⁶, the putative orthologues of hBD-1 and hBD-3, respectively.¹⁰ There is no clear orthologue of hBD-2. Indeed, due to differences in gene structure and tissue expression, *CBD102* is not similar to hBD-2.¹⁰ The *CBD102* gene contains three exons,¹⁰ and analysis of mRNA from multiple tissues indicates that *CBD102* expression is limited to the testes (B.C.L. and C.L.B., unpublished data), whereas the gene encoding hBD-2 (named *DEFB4*) has two exons and is broadly expressed in many tissues, including human skin and colon.^{19,21} Expression of feline β -defensins has not been reported to date; however,

feline β -defensin 103 (feBD103) expression has been identified in cat skin (B.C.L. and C.L.B., unpublished data).

Initially, hBD-1 was identified in haemofiltrate from dialysis patients and subsequently localized to epithelial cells from many tissues, including pancreas, kidney and skin.^{18,22,23} Expression of hBD-1 is constitutive. The promoter region of hBD-1 lacks transcription factor binding sites often involved in inflammation, such as nuclear factor- κ B or AP-1 (activator protein-1),²⁴ and the hBD-1 transcript is not upregulated during inflammation.²¹ In contrast, baseline expression of hBD-2 is low in human keratinocytes, but can be upregulated with inflammation or pathogenic stimulation.^{19,25,26} Analysis of the promoter region of hBD-2 has revealed two functional nuclear factor- κ B binding sites that are responsible, in part, for its upregulation.²⁷ Another β -defensin that exhibits inducible expression in human skin is hBD-3, the orthologue of CBD-103 in dogs. Expression of hBD-3 can be induced by tumour necrosis factor- α or contact with bacteria, and in wound-healing responses.^{26,28}

Studies have begun to explore β -defensin expression and function in dogs. Expression has been identified in the testes,²⁹ kidney, palatine tonsil, trachea, lung, gastrointestinal tract, liver, spleen, peripheral blood mononuclear cells, bone marrow and skin (Figure 4).^{4,6,30–32} To evaluate possible induced β -defensin expression, canine primary tracheal epithelial cells were treated with both lipopolysaccharide and canine respiratory coronavirus; however, neither stimulus was sufficient to upregulate CBD103 expression.³² Further studies are needed in order to understand patterns and regulation of canine defensin expression more fully.

Cathelicidins

Human cathelicidin, LL-37, exhibits constitutive and inducible expression in many different cell types. High levels of LL-37 are found in the bone marrow, and the peptide localizes to specific granules in the neutrophil.³³ Although constitutive LL-37 expression is very low in

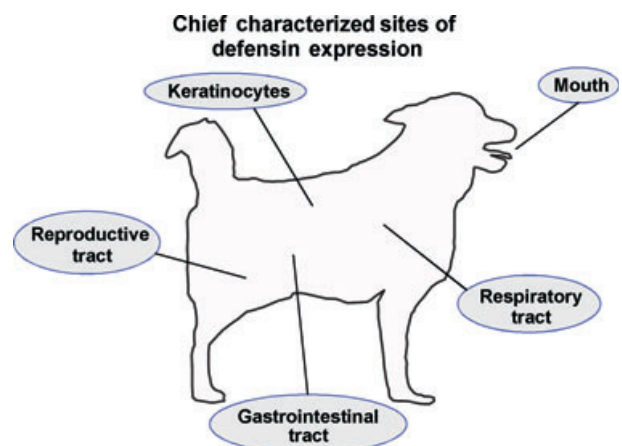

Figure 4. Differential expression of defensins. Defensins are expressed in epithelial cells in many different organs, including the mouth, skin, reproductive tract, gastrointestinal tract and lungs. In the dog, a variant of CBD103 is involved with the determination of coat colour.

keratinocytes, treatment with 1,25-(OH)₂ vitamin D₃ induced LL-37 mRNA expression 100-fold over baseline.³⁴ Vitamin D₃ also induces LL-37 expression in monocytes and macrophages, and can lead to enhanced intracellular killing³⁵ and promote autophagy in the co-ordinated killing of *Mycobacterium tuberculosis*.³⁶ This responsiveness to vitamin D₃ involves the vitamin D₃ responsive element (VDRE) in the 5' promoter region of the human cathelicidin gene.³⁷ When comparing cathelicidin genes across species, the VDRE is conserved among primates, but is not present in other species, including mice, dogs and cats.^{7,37}

Canine cathelicidin, K9CATH, is expressed in epithelial cells and leukocytes.^{16,31} High expression is seen in bone marrow, and lower levels are present in the gastrointestinal tract, liver, spleen, testes¹⁶ and skin.³¹ The 5' promoter region of K9CATH does not contain any VDRE sequences, suggesting that this gene will not respond to vitamin D₃.³⁷ This suggests that topical vitamin D₃ application to canine skin may not be clinically effective in increasing cathelicidin expression. Similar to its canine orthologue, feline cathelicidin, feCATH, is highly expressed in the bone marrow.⁷ The peptide immunolocalizes to neutrophils, with lower levels of expression detected in the skin.⁷ As in the canine gene, a VDRE sequence was not observed in the 5' promoter region of the gene.⁷

Activity of AMPs

Antimicrobial activity

Cationic AMPs are generally thought to exert their antimicrobial effect through permeabilization of target microbial membranes. The positively charged arginine and lysine residues of AMPs interact favourably with the negatively charged microbial membranes via electrostatic interaction.³⁸ This interaction has been demonstrated both with artificial vesicles composed of anionic lipids and with bacteria, such as *Escherichia coli*.^{39,40} Following charge-mediated interaction of AMPs and the membrane, the amphipathic nature of the peptide promotes hydrophobic integration into the membrane.³⁹ The result is initially formation of pores, which can dissipate electrochemical gradients, and at high concentrations of AMP, severe membrane disruption and a release of intracellular contents (Figure 5).³⁹

Interestingly, recent data have provided evidence for a specific intracellular target for some defensins against Gram-positive bacteria.^{41–44} Wei *et al.* synthesized several defensins using D-amino acids, rather than the natural L-isomers. Each defensin peptide retained equal activity against Gram-negative bacteria, presumably because the mechanism described above involving pore formation is independent of stereochemistry.⁴¹ In contrast, the D-enantiomers lost antimicrobial activity against *Staphylococcus aureus*, indicating the importance of peptide chirality for activity against Gram-positive bacteria. Subsequent studies demonstrate that Lipid II, an essential component for bacterial cell wall biosynthesis, is the target for (at least) some defensins against Gram-positive bacteria (Figure 5).^{42–44} These insights into specific mechanisms of antimicrobial killing may help propel development of novel therapeutics.

Recent studies have focused on the antimicrobial activity of canine AMPs and pathogens that frequently complicate chronic skin disease in dogs. Canine cathelicidin displayed potent, broad-spectrum antimicrobial activity against various pathogens, including *S. aureus*, *E. coli* and *Listeria monocytogenes*.¹⁶ In addition, Fazakerley *et al.*⁴⁵ demonstrated equal antimicrobial activity of synthetic hBD-3 against *Staphylococcus pseudintermedius* isolated from both healthy canine skin and dogs with atopic dermatitis.

Bacterial resistance

In retaliation to the antimicrobial defenses elaborated by a given host, pathogens have developed methods of resistance. Proteolytic degradation of AMPs is one mechanism by which bacteria evade innate immune measures.⁵ The human cathelicidin, LL-37, can be proteolytically degraded by bacterial proteases, including SpeB of *Streptococcus pyogenes* and elastase B of *Pseudomonas aeruginosa*.^{46,47} *Staphylococcus aureus* expresses a metalloproteinase, aureolysin, which can also degrade LL-37.⁴⁸ The intramolecular disulfide bonds of defensins help protect this class of AMP from proteolysis.⁴⁹

In addition to degradation, some pathogens express proteins that can directly bind and neutralize AMPs. Lysogenic strains of *S. aureus* produce staphylokinase, which binds defensins and inhibits their ability to kill.⁵⁰ Likewise, streptococci produce a protein called streptococcal inhibitor of complement that can neutralize defensins.⁵¹

Many bacteria have the ability to modulate the overall charge of their membranes, making them less anionic, and hence resistant to cationic AMPs. These enzyme-mediated modifications of lipopolysaccharide were first described in the Gram-negative pathogen *Salmonella Typhimurium*.⁵² The external bacterial membranes of the Gram-positive bacteria *S. aureus* and streptococci contain negatively charged teichoic acids. However, through the addition of positively charged D-alanine esters to teichoic acids, *S. aureus* and streptococci can repel the electrostatic attraction of cationic peptides, protecting the bacteria from AMPs.^{53,54} *Staphylococcus aureus* can modify the anionic phosphatidylglycerol on the bacterial membrane through the addition of cationic L-lysine.^{55,56} These examples of bacterial countermeasures represent ongoing coevolution of host–pathogen interactions. Insights into the molecular mechanisms of resistance to AMPs may aid in development of future therapeutics.

Chemotaxis

Investigations into the chemotactic activity of defensins and cathelicidins for leukocytes have helped to establish a link between AMPs and the adaptive immune system. Leukocytes are attracted by and migrate towards a gradient of AMPs expressed at the site of infection.⁵⁷ In humans, neutrophil-derived defensins and LL-37 can chemoattract monocytes, naive T cells and immature dendritic cells.^{58–60} Human β-defensins, including hBD-2 and hBD-3, expressed at the epithelial surface have the ability to chemoattract immature dendritic cells and memory T cells through the chemokine receptor CCR6.^{2,61} To gain insight into the structure–function relationship of these β-defensins, truncation mutants and

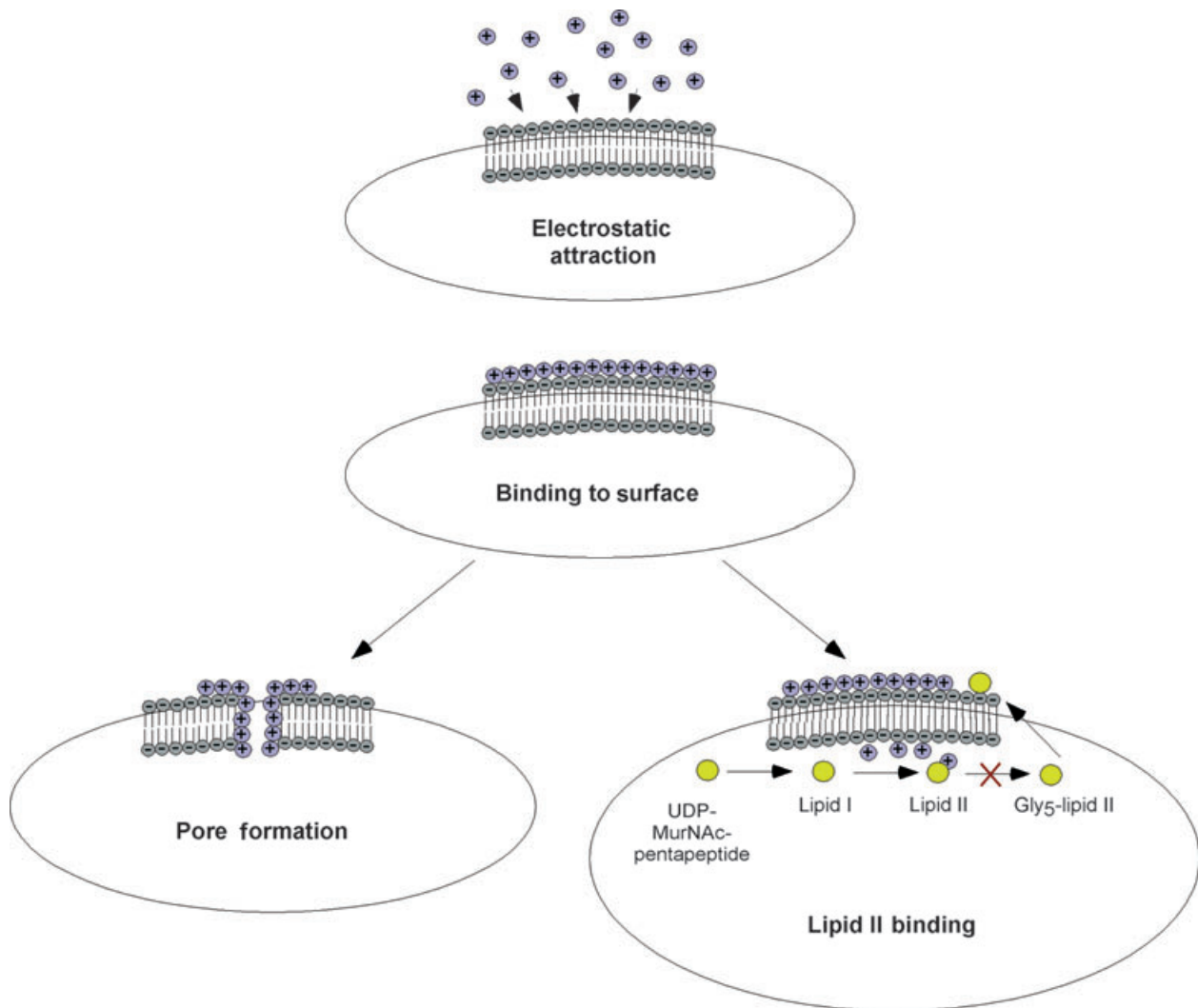

Figure 5. Schematic diagram of antimicrobial killing by antimicrobial peptides. Experimental evidence supports a model of initial electrostatic attraction of cationic peptides to anionic microbial membranes. Subsequent to binding, amphipathic peptides can insert into membranes to mediate bacterial killing. Recent evidence has shown that certain defensins can kill Gram-positive bacteria through binding Lipid II and preventing biosynthesis of peptidoglycan. Blue circles with (+) represent cationic peptides, grey circles with (-) represent anionic bacterial membranes, and yellow circles are intermediates in peptidoglycan biosynthesis. Red X indicates reaction step that is inhibited by cationic peptides binding to Lipid II. Figure adapted from both Ganz⁵ and Sass *et al.*⁴⁴

peptides lacking a complete disulfide array were generated.⁶² The data support the idea that both the tertiary structure surrounding the N-terminus and specific residues at this site mediate the interaction between hBD-3 and CCR6.^{62,63} This structure–function relationship has been further substantiated using the mouse orthologue of hBD-3, Defb14.^{62–64} Finally, hBD-2 and hBD-3 have been shown to be chemotactic for monocytes through CCR2.⁶⁵ It will be important to evaluate the chemotactic properties of canine and feline orthologues of the hBD-3, because it will provide increased knowledge of the interactions between AMPs and adaptive immunity, as well as providing insight into the structure–function relationships of β -defensins.

Coat colour

Besides serving host defense functions, recent investigations have implicated defensins in dominant black coat colour in dogs.⁴ Coat colour in mammals is primarily determined by the interaction of the Agouti peptide with

the melanocyte receptor, Mc1r (Figure 6).^{66–68} Constitutive signalling by Mc1r on the surface of melanocytes results in the production of eumelanin, or black pigment.⁶⁹ The Agouti peptide can bind Mc1r and antagonize Mc1r signalling, resulting in the production of pheomelanin, or red/yellow pigment within melanocytes.⁶⁸ Differential signalling and genetic variation in *Agouti* and *Mc1r* account for much of the variation found in mammalian coat colour.⁷⁰ In dogs, however, the dominant black coat colour, seen in breeds such as Labrador retrievers, could not be explained by simple interactions between Agouti and the Mc1r receptor.⁷¹

In 1957, Little hypothesized that dominant black coat colour in the domestic dog was due to an unusual allele of *Agouti*.⁷¹ Subsequent studies of dominant black colour proved that there is a separate gene, independent of *Agouti*, that is responsible for the phenotype, an allele in the canine genome termed the *K* locus.^{72,73} In 2007, Candille and colleagues⁴ identified *CBD103* as the gene responsible for the dominant black coat colour using link-

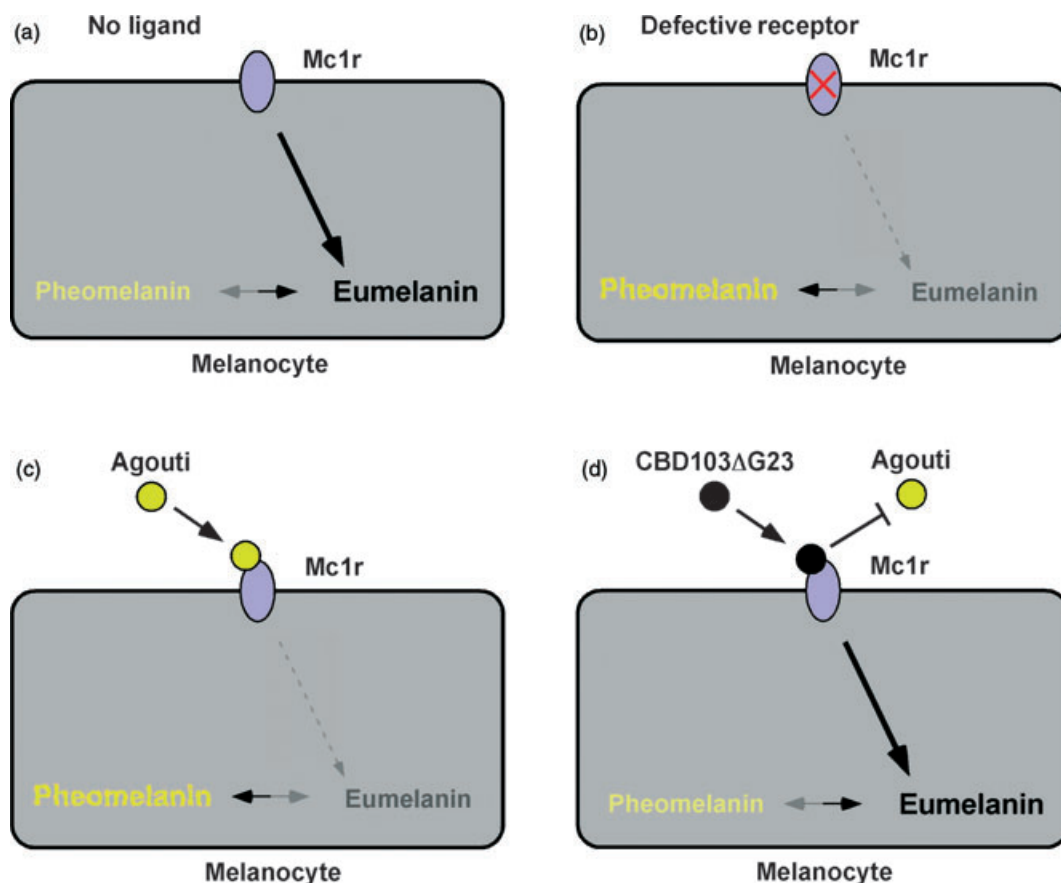

Figure 6. Coat colour determination in the dog. (a) Constitutive signalling of the Mc1r receptor, localized to the surface of melanocytes, in the absence of a ligand, resulting in the production of eumelanin (black pigment). (b) Defective Mc1r signalling results in the synthesis of pheomelanin (yellow or red pigment). (c) The Agouti peptide antagonizes the Mc1r signalling, resulting in the synthesis of pheomelanin. (d) The variant form of CBD103, CBD103ΔG23, serves as a neutral antagonist of Mc1r and allows the melanocyte to synthesize eumelanin. Figure adapted from Candille *et al.*⁴ with input from Gregory S. Barsh.

age and association mapping. Specifically, a variant of *CBD103*, referred to as *CBD103ΔG23*, was found to be responsible for dominant black coat colour. Compared with *CBD103*, *CBD103ΔG23* has a three base-pair deletion, resulting in omission of glycine residue 23 at the N-terminus of the mature defensin peptide.⁴ As a result, the CBD103ΔG23 variant peptide has the ability to bind to the Mc1r with high affinity, working as a neutral antagonist, thus preventing Agouti from binding and inhibiting this receptor.⁴ Binding of CBD103ΔG23 allows unabated signalling from Mc1r to synthesize eumelanin, or black pigment.⁴ This relationship between defensins and coat colour was quite unexpected and implies new possibilities for noncanonical functions of defensins, independent of innate immunity.

Reproduction

Defensins play an important role in sperm maturation, capacitation and adherence to uterine mucosal epithelial cells. As sperm migrate through the specialized regions of the epididymis, their surfaces are modified by the adsorption of various proteins made by epididymal cells, including certain β -defensins.^{74–76} For example, β -defensin 126 (DEFB126) is important for mobility of primate sperm through cervical mucus and binding to oviductal epithelial cells, which provides a reservoir of viable sperm

for fertilization.^{77,78} Manipulations of sperm that resulted in loss, masking or alteration of DEFB126 resulted in a reduced ability of the sperm to traverse cervical mucus and bind oviductal epithelial cells.^{77,78} A recent study reported that a genetic variant in *DEFB126* is common in humans and is associated with subfertility.⁷⁹

Genetic variation of AMPs

Genetic organization: gene copy-number polymorphism

Most mammalian genes are diploid, meaning that one copy is inherited maternally and another copy is inherited paternally, yielding a total of two gene copies per genome. However, recent investigations into genomic structure have identified many regions of genomic DNA that are present in multiple copies rather than diploid. Remarkably, for some regions the number of copies is variable from individual to individual.⁸⁰ This type of genetic variability exists not only in humans, but also in dogs, and is referred to as copy-number variation.⁸¹ Interestingly, the human β -defensin cluster on chromosome 8p23.1, including the genes that encode hBD-2 and hBD-3, have undergone duplication events whereby this cluster repeats more than once on a given chromosome, allowing for a total gene copy-number greater than two.^{82,83} In dogs, the orthologous gene cluster of β -defensins on chromo-

some 16, including *CBD103*, also exhibits gene copy-number variation (Figure 3),⁸⁴ although the extent of variation and breeds that specifically vary in copy number have yet to be reported. The relationship between gene copy-number variation and disease is being intensively studied.⁸³ Disorders associated with β -defensin gene copy number are discussed in the following section.

Antimicrobial peptides and disease

Psoriasis

Psoriasis is a common chronic inflammatory skin disease of humans that affects as many as 1–2% of the population in the USA. With the exception of a mouse model, psoriasis has not been recognized in other species, and it is not a disease of dogs or cats. However, salient features of this human disease provide an opportunity to illustrate roles of antimicrobial peptide in chronic inflammatory disorders. Psoriatic patients have overt skin lesions, but these lesions are rarely infected,⁸⁵ and the psoriatic scales overlying the lesions are especially rich in AMPs.¹⁹ High levels of hBD-2, hBD-3 and LL-37 have been extracted from the psoriatic scales, and epidermal mRNA expression is significantly higher in lesional skin when compared with either nonlesional skin or healthy skin from control subjects.^{19,25,86} The increased AMP expression and incorporation into the psoriatic scales is thought to prevent infection. On the contrary, the increased AMP expression could also exacerbate disease due to non-antimicrobial activities of AMPs, such as chemotaxis and DNA binding.⁸⁷

In addition to the increased AMP expression in psoriasis, Hollox *et al.*⁸⁸ have identified an association between psoriatic patients and increased gene copy number. In two separate population cohorts, individuals with six or more gene copy numbers in the β -defensin cluster on chromosome 8 (including hBD-2 and hBD-3) had an increased risk of developing psoriasis. On the contrary, individuals with two or three copies of the β -defensin cluster had a reduced risk of developing psoriasis.

Atopic dermatitis

Atopic dermatitis (AD) is a chronic inflammatory skin disease due to an allergic response to nonpathogenic environmental antigens, affecting upwards of 10% of human and canine populations.^{89–91} Clinical and histological similarities between human and canine AD allow researchers to make applicable comparisons.⁹² A similarity amongst human and canine patients with AD is the presence of a dysfunctional epidermal barrier.⁹² Secondary bacterial infections, *S. aureus* in humans and *Staphylococcus pseudintermedius* in dogs, can exploit the dysfunctional barrier, colonizing and complicating skin lesions of AD patients.⁹³

Ong *et al.*⁸⁶ demonstrated reduced expression of LL-37 and hBD-2 in AD lesional skin when compared with healthy and psoriatic skin. To study the mechanism of reduced AMP expression, the investigators exposed keratinocytes in culture to the T-helper 2 cytokines interleukin-4 (IL-4) and interleukin-13 (IL-13), both of which are known to be overexpressed in AD lesional

skin.⁸⁶ Treatment of keratinocytes with IL-4 and IL-13 reduced the expression of hBD-2, even when co-cultured with the proinflammatory cytokine, tumour necrosis factor- α .⁸⁶ Another study of AD skin lesions revealed that hBD-3, known to have anti-staphylococcal activity, was also reduced in AD lesional skin due to the presence of IL-4 and IL-13.⁹⁴ In addition, it has been observed that AD patients have reduced mobilization of hBD-3, predisposing them to *S. aureus* infection.⁹⁵ However, a recent study by Harder and colleagues demonstrates increased AMP expression in patients with AD when compared with nonlesional skin and control subjects.⁹⁶ It is possible to conclude that AD patients with severe disease and a history of recurrent skin infections are unable to upregulate AMP fully to levels required to prevent complicating infections.

In canine AD, CBD1 has been shown to have increased expression in lesional and nonlesional skin when compared with healthy control animals.³⁰ In contrast, lesional and nonlesional skin exhibited reduced expression of CBD103.³⁰ This reduction of CBD103 expression may predispose dogs with AD to developing secondary *S. pseudintermedius* infections.

Conclusions

Antimicrobial peptides play an important role in host immunity, in particular at the skin–environment interface. Not only do they possess direct antimicrobial activity, but these peptides also play important roles in shaping host microbiota, chemotaxis, lectin binding, pathogen-associated molecular pattern neutralization, reproduction and coat colour in dogs. There is a great degree of variability in terms of the families and numbers of AMPs encoded by the genome of each species. It is likely that the repertoire of AMPs elaborated by each species is a reflection of their environmental niche, mainly the pathogens that they individually encounter. Importantly, altered expression of AMPs in certain disease states, such as canine and human AD, and psoriasis in humans, predisposes the host to secondary infection or exacerbation of ongoing inflammation, respectively. Further studies of AMPs in veterinary species are needed to define the expression of these peptides, determine genetic variations, evaluate antimicrobial activities, as well as other functions, and investigate their role in disease.

Acknowledgements

We would like to thank Hiutung Chu for critical reading of the manuscript.

References

1. Zasloff M. Antimicrobial peptides of multicellular organisms. *Nature* 2002; 415: 389–395.
2. Yang D, Chertov O, Bykovskaia SN *et al.* Beta-defensins: linking innate and adaptive immunity through dendritic and T cell CCR6. *Science* 1999; 286: 525–528.
3. Frohm M, Gunne H, Bergman AC *et al.* Biochemical and antibacterial analysis of human wound and blister fluid. *Eur J Biochem* 1996; 237: 86–92.

4. Candille SI, Kaelin CB, Cattanach BM *et al.* A β -defensin mutation causes black coat color in domestic dogs. *Science* 2007; 318: 1418–1423.
5. Ganz T. Defensins: antimicrobial peptides of innate immunity. *Nat Rev Immunol* 2003; 3: 710–720.
6. Wingate KV, Torres SM, Silverstein KA *et al.* Expression of endogenous antimicrobial peptides in normal canine skin. *Vet Dermatol* 2009; 20: 19–26.
7. Leonard BC, Chu H, Johns JL *et al.* Expression and activity of a novel cathelicidin from domestic cats. *PLoS ONE* 2011; 6: e18756.
8. Borkowski AW, Gallo RL. The coordinated response of the physical and antimicrobial peptide barriers of the skin. *J Invest Dermatol* 2011; 131: 285–287.
9. Saito T, Kawabata S, Shigenaga T *et al.* A novel big defensin identified in horseshoe crab hemocytes: isolation, amino acid sequence, and antibacterial activity. *J Biochem* 1995; 117: 1131–1137.
10. Patil AA, Cai Y, Sang Y *et al.* Cross-species analysis of the mammalian β -defensin gene family: presence of syntenic gene clusters and preferential expression in the male reproductive tract. *Physiol Genomics* 2005; 23: 5–17.
11. Patil A, Hughes AL, Zhang G. Rapid evolution and diversification of mammalian α -defensins as revealed by comparative analysis of rodent and primate genes. *Physiol Genomics* 2004; 20: 1–11.
12. Tang YQ, Yuan J, Osapay G *et al.* A cyclic antimicrobial peptide produced in primate leukocytes by the ligation of two truncated alpha-defensins. *Science* 1999; 286: 498–502.
13. Zanetti M. The role of cathelicidins in the innate host defenses of mammals. *Curr Issues Mol Biol* 2005; 7: 179–196.
14. Zanetti M, Gennaro R, Romeo D. Cathelicidins: a novel protein family with a common proregion and a variable C-terminal antimicrobial domain. *FEBS Lett* 1995; 374: 1–5.
15. Zanetti M. Cathelicidins, multifunctional peptides of the innate immunity. *J Leukoc Biol* 2004; 75: 39–48.
16. Sang Y, Teresa Ortega M, Rune K *et al.* Canine cathelicidin (K9CATH): gene cloning, expression, and biochemical activity of a novel pro-myeloid antimicrobial peptide. *Dev Comp Immunol* 2007; 31: 1278–1296.
17. Schaubert J, Gallo RL. Antimicrobial peptides and the skin immune defense system. *J Allergy Clin Immunol* 2008; 122: 261–266.
18. Ali RS, Falconer A, Ikram M *et al.* Expression of the peptide antibiotics human β defensin-1 and human β defensin-2 in normal human skin. *J Invest Dermatol* 2001; 117: 106–111.
19. Harder J, Bartels J, Christophers E *et al.* A peptide antibiotic from human skin. *Nature* 1997; 387: 861.
20. Harder J, Bartels J, Christophers E *et al.* Isolation and characterization of human β -defensin-3, a novel human inducible peptide antibiotic. *J Biol Chem* 2001; 276: 5707–5713.
21. O'Neil DA, Porter EM, Elewaut D *et al.* Expression and regulation of the human β -defensins hBD-1 and hBD-2 in intestinal epithelium. *J Immunol* 1999; 163: 6718–6724.
22. Bensch KW, Raida M, Mägert HJ *et al.* hBD-1: a novel β -defensin from human plasma. *FEBS Lett* 1995; 368: 331–335.
23. Valore EV, Park CH, Quayle AJ *et al.* Human β -defensin-1: an antimicrobial peptide of urogenital tissues. *J Clin Invest* 1998; 101: 1633–1642.
24. Liu L, Zhao C, Heng HH *et al.* The human β -defensin-1 and α -defensins are encoded by adjacent genes: two peptide families with differing disulfide topology share a common ancestry. *Genomics* 1997; 43: 316–320.
25. Liu L, Wang L, Jia HP *et al.* Structure and mapping of the human β -defensin HBD-2 gene and its expression at sites of inflammation. *Gene* 1998; 222: 237–244.
26. Wolk K, Kunz S, Witte E *et al.* IL-22 increases the innate immunity of tissues. *Immunity* 2004; 21: 241–254.
27. Kao CY, Kim C, Huang F *et al.* Requirements for two proximal NF- κ B binding sites and I κ B- ζ in IL-17A-induced human β -defensin 2 expression by conducting airway epithelium. *J Biol Chem* 2008; 283: 15309–15318.
28. Harder G, McGowan R. Isolation and characterization of the muscle-specific isoform of creatine kinase from the zebrafish, *Danio rerio*. *Biochem Cell Biol* 2001; 79: 779–782.
29. Sang Y, Ortega MT, Blecha F *et al.* Molecular cloning and characterization of three β -defensins from canine testes. *Infect Immun* 2005; 73: 2611–2620.
30. van Damme CM, Willemse T, van Dijk A *et al.* Altered cutaneous expression of β -defensins in dogs with atopic dermatitis. *Mol Immunol* 2009; 46: 2449–2455.
31. Santoro D, Bunick D, Graves TK *et al.* Expression and distribution of antimicrobial peptides in the skin of healthy beagles. *Vet Dermatol* 2010; 22: 61–67.
32. Erles K, Brownlie J. Expression of β -defensins in the canine respiratory tract and antimicrobial activity against *Bordetella bronchiseptica*. *Vet Immunol Immunopathol* 2010; 135: 12–19.
33. Cowland JB, Johnsen AH, Borregaard N. hCAP-18, a cathelin/pro-bactenecin-like protein of human neutrophil specific granules. *FEBS Lett* 1995; 368: 173–176.
34. Schaubert J, Dorschner RA, Yamasaki K *et al.* Control of the innate epithelial antimicrobial response is cell-type specific and dependent on relevant microenvironmental stimuli. *Immunology* 2006; 118: 509–519.
35. Liu PT, Stenger S, Tang DH *et al.* Cutting edge: vitamin D-mediated human antimicrobial activity against *Mycobacterium tuberculosis* is dependent on the induction of cathelicidin. *J Immunol* 2007; 179: 2060–2063.
36. Yuk JM, Shin DM, Lee HM *et al.* Vitamin D3 induces autophagy in human monocytes/macrophages via cathelicidin. *Cell Host Microbe* 2009; 6: 231–243.
37. Gombart AF, Borregaard N, Koeffler HP. Human cathelicidin antimicrobial peptide (CAMP) gene is a direct target of the vitamin D receptor and is strongly up-regulated in myeloid cells by 1,25-dihydroxyvitamin D₃. *FASEB J* 2005; 19: 1067–1077.
38. Fujii G, Selsted ME, Eisenberg D. Defensins promote fusion and lysis of negatively charged membranes. *Protein Sci* 1993; 2: 1301–1312.
39. Wimley WC, Selsted ME, White SH. Interactions between human defensins and lipid bilayers: evidence for formation of multimeric pores. *Protein Sci* 1994; 3: 1362–1373.
40. Lehrer RI, Barton A, Daher KA *et al.* Interaction of human defensins with *Escherichia coli*. Mechanism of bactericidal activity. *J Clin Invest* 1989; 84: 553–561.
41. Wei G, de Leeuw E, Pazzgier M *et al.* Through the looking glass, mechanistic insights from enantiomeric human defensins. *J Biol Chem* 2009; 284: 29180–29192.
42. Schneider T, Kruse T, Wimmer R *et al.* Plectasin, a fungal defensin, targets the bacterial cell wall precursor Lipid II. *Science* 2010; 328: 1168–1172.
43. de Leeuw E, Li C, Zeng P *et al.* Functional interaction of human neutrophil peptide-1 with the cell wall precursor lipid II. *FEBS Lett* 2010; 584: 1543–1548.
44. Sass V, Schneider T, Wilmes M *et al.* Human β -defensin 3 inhibits cell wall biosynthesis in staphylococci. *Infect Immun* 2010; 78: 2793–2800.
45. Fazakerley J, Crossley J, McEwan N *et al.* *In vitro* antimicrobial efficacy of β -defensin 3 against *Staphylococcus pseudintermedius* isolates from healthy and atopic canine skin. *Vet Dermatol* 2010; 21: 463–468.
46. Schmidtchen A, Frick IM, Andersson E *et al.* Proteinases of common pathogenic bacteria degrade and inactivate the antibacterial peptide LL-37. *Mol Microbiol* 2002; 46: 157–168.
47. Nyberg P, Rasmussen M, Björck L. α_2 -Macroglobulin-proteinase complexes protect *Streptococcus pyogenes* from killing by the antimicrobial peptide LL-37. *J Biol Chem* 2004; 279: 52820–52823.
48. Sieprawska-Lupa M, Mydel P, Krawczyk K *et al.* Degradation of human antimicrobial peptide LL-37 by *Staphylococcus aureus*

- derived proteinases. *Antimicrob Agents Chemother* 2004; 48: 4673–4679.
49. Maemoto A, Qu X, Rosengren KJ *et al.* Functional analysis of the α -defensin disulfide array in mouse cryptdin-4. *J Biol Chem* 2004; 279: 44188–44196.
 50. Jin T, Bokarewa M, Foster T *et al.* *Staphylococcus aureus* resists human defensins by production of staphylokinase, a novel bacterial evasion mechanism. *J Immunol* 2004; 172: 1169–1176.
 51. Fernie-King BA, Seilly DJ, Lachmann PJ. The interaction of streptococcal inhibitor of complement (SIC) and its proteolytic fragments with the human beta defensins. *Immunology* 2004; 111: 444–452.
 52. Guo L, Lim KB, Poduje CM *et al.* Lipid A acylation and bacterial resistance against vertebrate antimicrobial peptides. *Cell* 1998; 95: 189–198.
 53. Peschel A, Otto M, Jack RW *et al.* Inactivation of the *dlt* operon in *Staphylococcus aureus* confers sensitivity to defensins, protegrins, and other antimicrobial peptides. *J Biol Chem* 1999; 274: 8405–8410.
 54. Kristian SA, Datta V, Weidenmaier C *et al.* D-Alanylation of teichoic acids promotes group A streptococcus antimicrobial peptide resistance, neutrophil survival, and epithelial cell invasion. *J Bacteriol* 2005; 187: 6719–6725.
 55. Staubitz P, Neumann H, Schneider T *et al.* MprF-mediated biosynthesis of lysylphosphatidylglycerol, an important determinant in staphylococcal defensin resistance. *FEMS Microbiol Lett* 2004; 231: 67–71.
 56. Nishi H, Komatsuzawa H, Fujiwara T *et al.* Reduced content of lysyl-phosphatidylglycerol in the cytoplasmic membrane affects susceptibility to moenomycin, as well as vancomycin, gentamicin, and antimicrobial peptides, in *Staphylococcus aureus*. *Antimicrob Agents Chemother* 2004; 48: 4800–4807.
 57. Lai Y, Gallo RL. AMPed up immunity: how antimicrobial peptides have multiple roles in immune defense. *Trends Immunol* 2009; 30: 131–141.
 58. Territo MC, Ganz T, Selsted ME *et al.* Monocyte-chemotactic activity of defensins from human neutrophils. *J Clin Invest* 1989; 84: 2017–2020.
 59. Chertov O, Michiel DF, Xu L *et al.* Identification of defensin-1, defensin-2, and CAP37/azurocidin as T-cell chemoattractant proteins released from interleukin-8-stimulated neutrophils. *J Biol Chem* 1996; 271: 2935–2940.
 60. Yang D, Chen Q, Chertov O *et al.* Human neutrophil defensins selectively chemoattract naive T and immature dendritic cells. *J Leukoc Biol* 2000; 68: 9–14.
 61. Rohrl J, Yang D, Oppenheim JJ *et al.* Specific binding and chemotactic activity of mBD4 and its functional orthologue hBD2 to CCR6-expressing cells. *J Biol Chem* 2010; 285: 7028–7034.
 62. Taylor K, Clarke DJ, McCullough B *et al.* Analysis and separation of residues important for the chemoattractant and antimicrobial activities of β -defensin 3. *J Biol Chem* 2008; 283: 6631–6639.
 63. Tyrrell C, De Cecco M, Reynolds NL *et al.* Isoleucine/leucine² is essential for chemoattractant activity of β -defensin Defb14 through chemokine receptor 6. *Mol Immunol* 2010; 47: 1378–1382.
 64. Rohrl J, Yang D, Oppenheim JJ *et al.* Identification and biological characterization of mouse β -defensin 14, the orthologue of human β -defensin 3. *J Biol Chem* 2008; 283: 5414–5419.
 65. Rohrl J, Yang D, Oppenheim JJ *et al.* Human β -defensin 2 and 3 and their mouse orthologs induce chemotaxis through interaction with CCR2. *J Immunol* 2010; 184: 6688–6694.
 66. Chhajlani V, Wikberg JE. Molecular cloning and expression of the human melanocyte stimulating hormone receptor cDNA. *FEBS Lett* 1992; 309: 417–420.
 67. Bultman SJ, Michaud EJ, Woychik RP. Molecular characterization of the mouse agouti locus. *Cell* 1992; 71: 1195–1204.
 68. Ollmann MM, Lamoreux ML, Wilson BD *et al.* Interaction of Agouti protein with the melanocortin 1 receptor in vitro and in vivo. *Genes Dev* 1998; 12: 316–330.
 69. Slominski A, Plonka PM, Pisarchik A *et al.* Preservation of eumelanin hair pigmentation in proopiomelanocortin-deficient mice on a nonagouti (*a/a*) genetic background. *Endocrinology* 2005; 146: 1245–1253.
 70. Barsh GS. Regulation of pigment type switching by Agouti. In: Nordlund JJ, Boissy RE, Hearing VJ *et al.* eds. *The Pigmentary System*, 2nd edition. Oxford: Blackwell, 2006: 395–410.
 71. Little CC. *The Inheritance of Coat Color in Dogs*. New York: Howell Book House, 1957: 49–68.
 72. Kerns JA, Olivier M, Lust G *et al.* Exclusion of *Melanocortin-1 receptor (mc1r)* and *agouti* as candidates for dominant black in dogs. *J Hered* 2003; 94: 75–79.
 73. Kerns JA, Cargill EJ, Clark LA *et al.* Linkage and segregation analysis of black and brindle coat color in domestic dogs. *Genetics* 2007; 176: 1679–1689.
 74. Yudin AI, Tollner TL, Li MW *et al.* ESP13.2, a member of the β -defensin family, is a macaque sperm surface-coating protein involved in the capacitation process. *Biol Reprod* 2003; 69: 1118–1128.
 75. Yudin AI, Tollner TL, Treece CA *et al.* β -Defensin 22 is a major component of the mouse sperm glycocalyx. *Reproduction* 2008; 136: 753–765.
 76. Zhao Y, Diao H, Ni Z *et al.* The epididymis-specific antimicrobial peptide β -defensin 15 is required for sperm motility and male fertility in the rat (*Rattus norvegicus*). *Cell Mol Life Sci* 2011; 68: 697–708.
 77. Tollner TL, Yudin AI, Tarantal AF *et al.* Beta-defensin 126 on the surface of macaque sperm mediates attachment of sperm to oviductal epithelia. *Biol Reprod* 2008; 78: 400–412.
 78. Tollner TL, Yudin AI, Treece CA *et al.* Macaque sperm coating protein DEFB126 facilitates sperm penetration of cervical mucus. *Hum Reprod* 2008; 23: 2523–2534.
 79. Tollner TL, Venners SA, Hollox EJ *et al.* A common mutation in the defensin DEFB126 causes impaired sperm function and subfertility. *Sci Transl Med* 2011; 3: 92ra65.
 80. Beckmann JS, Estivill X, Antonarakis SE. Copy number variants and genetic traits: closer to the resolution of phenotypic to genotypic variability. *Nat Rev Genet* 2007; 8: 639–646.
 81. Nicholas TJ, Cheng Z, Ventura M *et al.* The genomic architecture of segmental duplications and associated copy number variants in dogs. *Genome Res* 2009; 19: 491–499.
 82. Linzmeier RM, Ganz T. Human defensin gene copy number polymorphisms: comprehensive analysis of independent variation in α - and β -defensin regions at 8p22–p23. *Genomics* 2005; 86: 423–430.
 83. Hollox EJ. Copy number variation of β -defensins and relevance to disease. *Cytogenet Genome Res* 2008; 123: 148–155.
 84. Chen WK, Swartz JD, Rush LJ *et al.* Mapping DNA structural variation in dogs. *Genome Res* 2009; 19: 500–509.
 85. Henseler T, Christophers E. Disease concomitance in psoriasis. *J Am Acad Dermatol* 1995; 32: 982–986.
 86. Ong PY, Ohtake T, Brandt C *et al.* Endogenous antimicrobial peptides and skin infections in atopic dermatitis. *N Engl J Med* 2002; 347: 1151–1160.
 87. Lande R, Gregorio J, Facchinetti V *et al.* Plasmacytoid dendritic cells sense self-DNA coupled with antimicrobial peptide. *Nature* 2007; 449: 564–569.
 88. Hollox EJ, Huffmeier U, Zeeuwen PL *et al.* Psoriasis is associated with increased β -defensin genomic copy number. *Nat Genet* 2008; 40: 23–25.
 89. Feijen M, Gerritsen J, Postma DS. Genetics of allergic disease. *Br Med Bull* 2000; 56: 894–907.
 90. Williams HC. Epidemiology of atopic dermatitis. *Clin Exp Dermatol* 2000; 25: 522–529.
 91. Hillier A, Griffin CE. The ACVD task force on canine atopic dermatitis (II): incidence and prevalence. *Vet Immunol Immunopathol* 2001; 81: 147–151.
 92. Marsella R, Girolomoni G. Canine models of atopic dermatitis: a useful tool with untapped potential. *J Invest Dermatol* 2009; 129: 2351–2357.

93. Leung DY. Atopic dermatitis: new insights and opportunities for therapeutic intervention. *J Allergy Clin Immunol* 2000; 105: 860–876.
94. Nomura I, Goleva E, Howell MD *et al.* Cytokine milieu of atopic dermatitis, as compared to psoriasis, skin prevents induction of innate immune response genes. *J Immunol* 2003; 171: 3262–3269.
95. Kisich KO, Carspecken CW, Fiéve S *et al.* Defective killing of *Staphylococcus aureus* in atopic dermatitis is associated with reduced mobilization of human β -defensin-3. *J Allergy Clin Immunol* 2008; 122: 62–68.
96. Harder J, Dressel S, Wittersheim M *et al.* Enhanced expression and secretion of antimicrobial peptides in atopic dermatitis and after superficial skin injury. *J Invest Dermatol* 2010; 130: 1355–1364.

Résumé

Au cours de ces 20 dernières années, il y a eu d'importantes avancées de la compréhension des rôles des peptides antimicrobiens dans leurs fonctions homéostatiques et leur implication dans la pathogénie des maladies. En plus de leur activité antimicrobienne directe, ces peptides participent à de nombreuses fonctions cellulaires, comprenant la chimiotaxie, la cicatrisation et même la détermination de la couleur de pelage chez le chien. Des approches biologiques et génétiques variées ont aidé à élucider le rôle des peptides antimicrobiens au niveau de l'immunité innée et des défenses de l'hôte.

Les associations entre les peptides antimicrobiens et diverses dermatoses, incluant le psoriasis, la rosacée et la dermatite atopique ont été documentées chez l'homme. A plus long terme, la modulation thérapeutique de l'expression des peptides antimicrobiens pourraient fournir de nouveaux traitements efficaces de ces maladies.

Cet article passe en revue les connaissances actuelles sur les peptides antimicrobiens de la peau et des leucocytes circulants. Un accent particulier est donné sur la pertinence de la physiologie et des maladies chez les animaux domestiques.

Resumen

Durante los últimos 20 años ha habido avances significativos para entender el papel de los péptidos antimicrobianos en las funciones homeostáticas y su implicación en la patogenia de las enfermedades. Además de tener actividad antimicrobiana directa, estos péptidos participan en muchas funciones celulares, incluyendo quimiotaxis, cicatrización de heridas, e incluso la determinación del color de la capa en perros. Diversas investigaciones biológicas y genéticas han ayudado a aclarar el papel de los péptidos antimicrobianos en la inmunidad innata y en la defensa del hospedador.

En seres humanos se han documentado las asociaciones de péptidos antimicrobianos con varias enfermedades de la piel, incluyendo psoriasis, rosacea y dermatitis atópica. A más largo plazo, la modulación terapéutica de la expresión de péptidos antimicrobianos puede proporcionar nuevos tratamientos eficaces frente a enfermedades.

Esta revisión ensalza el conocimiento actual sobre péptidos antimicrobianos de la piel y de los leucocitos circulantes, con particular énfasis en la importancia de la fisiología y el estado de enfermedad en animales de compañía.

Zusammenfassung

Im Verlauf der letzten 20 Jahre hat es signifikante Durchbrüche bezüglich dem Verständnis der Rolle, die antimikrobielle Peptide bei der Funktion der Homoöstate spielen, sowie ihre Beteiligung bei der Pathogenese von Krankheiten gegeben. Zusätzlich zu ihrer direkten antimikrobiellen Wirkung spielen diese Peptide eine Rolle bei zahlreichen zellulären Funktionen, wie bei der Chemotaxis, bei der Wundheilung und sogar bei der Bestimmung der Haarfarbe des Hundefells. Verschiedene biologische und genetische Ansätze haben dazu beigetragen, die Rolle der antimikrobiellen Peptide im Bezug auf angeborene Immunität und Abwehrmechanismen des Organismus zu beleuchten.

Die Zusammenhänge antimikrobieller Peptide mit zahlreichen Hauterkrankungen, wie Psoriasis, Rosacea und atopischer Dermatitis sind beim Menschen beschrieben. Auf lange Sicht könnte eine therapeutische Modulation der Expression der antimikrobiellen Peptide wirksame neue Behandlungen für Krankheiten bereitstellen.

Diese Review befasst sich vor allem mit dem momentanen Wissen über antimikrobielle Peptide der Haut und zirkulierender Leukozyten mit speziellem Fokus ihrer Relevanz im Bezug auf Physiologie und Erkrankungen bei Haustieren.

要約

過去 20 年以上、恒常性維持機能における抗菌ペプチドの役割ならびに疾患の病因への関与に関する理解は著しく深まっている。直接の抗菌作用に加えて、これらのペプチドは走化性、創傷治癒、さらに犬の被毛の色の決定などの多くの細胞機能に関与している。様々な生物学的、遺伝学的なアプローチの助けにより、先天性免疫能と宿主の防御能についての抗菌ペプチドの役割が解明されてきた。

乾癬、酒さ、アトピー性皮膚炎など、ヒトでは様々な皮膚疾患と抗菌性ペプチドの関係が報告されている。さらに長期間では、治療による抗菌ペプチド発現調節は疾患に対して新しい治療となり可能性がある。

この総説では、皮膚ならびに循環白血球中の抗菌ペプチドに関する最近の情報、特に生理学と愛玩動物の疾患の関連について焦点を絞って記述した。

摘要

在过去的二十年里，对抗菌肽在机体自我平衡功能和参与发病机制的理解上有重大的研究进展。除直接抗菌活性外，这些多肽参与多种细胞功能，包括趋药性、伤口愈合、甚至决定犬的毛色。各种生物和遗传途径有助于阐明抗菌肽对先天免疫与机体防御的作用。

抗菌肽与各种皮肤疾病的关系，包括银屑病、红斑痤疮（酒糟鼻）和异位性皮炎，人医研究做出了研究。长久来看，抗菌肽治疗表现的调节可能提供有效的治疗方案。

本文回顾了当前皮肤抗菌肽和循环白细胞的知识，特别关注了与伴侣动物生理和疾病的关系。