

Lawrence Berkeley National Laboratory

Recent Work

Title

PHOTOLYSIS OF NITROGEN DIOXIDE TO PRODUCE NITROGEN PENTOXIDE

Permalink

<https://escholarship.org/uc/item/897899zz>

Authors

Harker, Alan
Johnston, H.S.

Publication Date

1972-12-01

PHOTOLYSIS OF NITROGEN DIOXIDE TO
PRODUCE NITROGEN PENTOXIDE

Alan Harker and H. S. Johnston

RECEIVED
LAWRENCE
RADIATION LABORATORY

December 1972

LIBRARY AND
DOCUMENTS SECTION

Prepared for the U. S. Atomic Energy Commission
under Contract W-7405-ENG-48

TWO-WEEK LOAN COPY

*This is a Library Circulating Copy
which may be borrowed for two weeks.
For a personal retention copy, call
Tech. Info. Division, Ext. 5545*



LBL-1425
c.2

AMT

DISCLAIMER

This document was prepared as an account of work sponsored by the United States Government. While this document is believed to contain correct information, neither the United States Government nor any agency thereof, nor the Regents of the University of California, nor any of their employees, makes any warranty, express or implied, or assumes any legal responsibility for the accuracy, completeness, or usefulness of any information, apparatus, product, or process disclosed, or represents that its use would not infringe privately owned rights. Reference herein to any specific commercial product, process, or service by its trade name, trademark, manufacturer, or otherwise, does not necessarily constitute or imply its endorsement, recommendation, or favoring by the United States Government or any agency thereof, or the Regents of the University of California. The views and opinions of authors expressed herein do not necessarily state or reflect those of the United States Government or any agency thereof or the Regents of the University of California.

Photolysis of Nitrogen Dioxide to Produce Nitrogen Pentoxide

Alan Harker and H.S. Johnston
 Department of Chemistry
 and Inorganic Materials Research Division,
 Lawrence Berkeley Laboratory,
 University of California, Berkeley, California 94720

Abstract

Nitrogen dioxide was photolyzed at room temperature in a long-path infrared cell. The concentrations of nitrogen dioxide and nitrogen pentoxide (N_2O_5) were followed as a function of time, and the molecular modulation spectrum of nitrogen dioxide was obtained in a steady-flow experiment. With one atmosphere of nitrogen, the observations were the rate constant ratios and standard deviations: $k_1[M]/k_2 = 0.18 \pm 0.01$, $k_3[M]/k_2 = 0.22 \pm 0.01$, $k_4/K = 0.71 \pm 0.02 \text{ sec}^{-1}$ where

1. $NO + O + M \rightarrow NO_2 + M$
2. $NO_2 + O \rightarrow NO + O_2$
3. $NO_2 + O + M \rightarrow NO_3 + M$
4. $NO_3 + NO \rightarrow 2NO_2$

$$K = ([N_2O_5]/[NO_2][NO_3])_{eq}$$

By using literature values for k_1 ($6.9 \times 10^{-32} \text{ cm}^3 \text{ molecule}^{-1} \text{ sec}^{-1}$) and for K ($1.24 \times 10^{-11} \text{ cm}^{-3}$), the values of the elementary rate constants are: $k_2 = 9.2 \times 10^{-12} \text{ cm}^3 \text{ molecule}^{-1} \text{ sec}^{-1}$, $k_3 = 8.2 \times 10^{-32} \text{ cm}^6 \text{ molecule}^{-1} \text{ sec}^{-1}$, and $k_4 = 8.7 \times 10^{-12} \text{ cm}^3 \text{ molecule}^{-1} \text{ sec}^{-1}$.

INTRODUCTION

The photolysis of nitrogen dioxide is a key reaction in photochemical air pollution¹, is important in stratospheric photochemistry², and is often used in the laboratory to measure light intensity between 300 and 400 nm. The reaction is complex, and there is disagreement in the literature as to the value of certain rate constants and rate-constant ratios. There is agreement in the literature^{3,4,5} that the following mechanism describes the overall kinetics of the photolysis of small amounts of NO₂ in an inert carrier gas.

Reaction	Rate
a. NO ₂ + hν → NO + O(³ P)	αI [NO ₂]
1. NO + O + M → NO ₂ + M	k ₁ [M] [NO] [O]
2. NO ₂ + O → NO + O ₂	k ₂ [NO ₂] [O]
3. NO ₂ + O + M → NO ₃ + M	k ₃ [M] [NO ₂] [O]
4. NO ₃ + NO → 2NO ₂	k ₄ [NO ₃] [NO]
5. NO ₃ + NO ₂ + M → N ₂ O ₅ + M	k _{5M} [NO ₂] [NO ₃]
6. N ₂ O ₅ + M → NO ₂ + NO ₃ + M	k _{6M} [N ₂ O ₅]
7. O ₂ + O + M → O ₃ + M	k ₇ [M] [O ₂] [O]
8. NO + O ₃ → NO ₂ + O ₂	k ₈ [NO] [O ₃]

The purpose of this study was to examine this system with the molecular modulation technique⁶, and in particular to focus on the rate constants for reactions 2, 3, and 4 at room temperature.

Quantities measured in this study were the decay of NO_2 , the build-up and decay of N_2O_5 , and the molecular modulation of NO_2 during intermittent illumination of a steady flow system. In terms of the mechanism these measurements give the following information: At low pressures (below 50 torr) the M-gas dependent reactions (1 and 3) become negligible compared to reaction 2, and the decay of nitrogen dioxide can be described by

$$\left(\frac{d \ln [\text{NO}_2]}{dt} \right)_{P \rightarrow 0} = -2 \alpha I \quad (1)$$

At one atmosphere total pressure and with small initial NO concentration, the disappearance of NO is given as a good approximation by

$$\ln \frac{[\text{NO}_2]}{[\text{NO}_2]_0} = \frac{-2\alpha I t}{(1 + k_3[\text{M}]/k_2)} = -k_a t \quad (2)$$

where k_a is the empirical, first-order, decay constant. If the initial concentration of nitric oxide is close to zero, the initial rate of formation of dinitrogen pentoxide is

$$\left(\frac{d[\text{N}_2\text{O}_5]}{dt} \right)_{t \rightarrow 0} = \frac{\alpha I [\text{NO}_2]}{(1 + k_2/k_3[\text{M}])} \quad (3)$$

At an early stage of the reaction ($t=t^*$) dinitrogen pentoxide goes through a maximum, at which point

$$\left(\frac{[\text{N}_2\text{O}_5]}{[\text{NO}_2]} \right)^* = \frac{\alpha I (k/k_4)}{(1 + k_2/k_3[\text{M}])} \left(\frac{[\text{NO}_2]}{[\text{NO}]} \right)^* \quad (4)$$

where $K = k_5/k_6$. The modulation amplitude of nitrogen dioxide in a steady flow system illuminated with square-wave photolyzing light of frequency f is

$$\frac{\Delta[\text{NO}_2]}{[\text{NO}_2]} = \frac{4\alpha I/\pi^2 f}{1 + \frac{k_1[\text{NO}]}{k_2[\text{NO}_2]} + \frac{k_3[\text{M}]}{k_2}} \quad (5)$$

It can be seen that Eq. 1 gives αI ; with αI so determined, Eqs. 2 and 3 give two independent measures of the ratio k_2/k_3 ; the combination of Eqs. 1, 2, and 5 gives k_1/k_2 .

Thus by solving the five experimental relationships simultaneously, it is possible to obtain values for αI , k_4/K , k_1/k_2 , and k_3/k_2 , with one equation redundant to use as a check. By taking the literature values for k_1 and for the equilibrium constant K , it is possible to obtain the elementary rate constants k_2 , k_3 , and k_4 .

EXPERIMENTAL

The instrument used in this work is a long path molecular modulation infrared spectrometer. A block diagram of the apparatus is shown in Figure 1. The reaction cell is a cylindrical quartz tube 91 cm long and 28.7 cm in diameter, with a volume of 67.0 liters. The cell is equipped with gold coated multiple reflection mirrors which give it a spectroscopic path length adjustable from 4 to 40 meters. The source of the IR radiation is a Nernst glower which is chopped at 400 cps by an American Time Products tuning fork. The monochromator is a McPherson

model 2051, one meter grating monochromator equipped with a 150 line per mm grating and order sorting filters. The IR detector is a liquid helium cooled, copper doped germanium photo conductor produced by the Santa Barbara Research Center.

The photolytic light for these experiments was supplied by four, 32 inch G.E. 30 watt, F30T8/BL black lamps. The photolytic photon flux in the cell is on the order of 10^{16} photons/cm²-sec. The photolysis lamp output for the cell is monitored by a phototransistor, which can be used as a reference to detect fluctuations in the lamp intensities. The photolysis lamps are driven by a regulated power supply which can electronically switch them on and off in response to a reference square wave from a crystal oscillator.

The electronics for the instrument are designed to detect the periodic concentration fluctuations in the absorbing gases in the cell which are induced by the flashing of the photolysis lamps. This is done by two sequential stages of demodulation. The 400 cps AC signal from the detector carries the modulation information on sidebands at $400 \pm f$ cps, where f is the frequency of the flashing lamps. The first demodulation is carried out by a 400 cps lock-in amplifier which produces a DC signal directly proportional to the spectroscopic light intensity. Riding on this DC signal as a low frequency ripple is the modulation information. This DC signal is split in two with one component being recorded while the other is AC coupled, filtered, and sent into the second stage of demodulation. The second stage demodulator is a set of two lock-ins, operating at frequency f ,

with one lock-in reference in phase with the photolysis lamps and one reference exactly 90° out of phase. The outputs of these two lock-ins represent the amplitude of the sine and cosine components of the first fundamental of the modulation signal. From these values the phase shift and amplitude of the modulation signal can be calculated. The output of all three lock-in amplifiers are recorded and time averaged in a signal averaging computer.

The carrier gases used in the experiments were high purity nitrogen and argon, both of which were passed through a Matheson water-and-particulate removal filter before use. The nitrogen dioxide used in the closed cell photolysis experiments was prepared by vacuum distillation from bulk liquid N_2O_4 . The NO_2 used in the flow experiments was commercial mixed gas supplied by Matheson. The gas was analyzed by IR and UV spectroscopy in this laboratory and found to contain 970 ± 5 ppm NO_2 and 38 ± 4 ppm NO , with the remainder being N_2 . The concentrations of all NO_x species involved in this work were determined spectroscopically from absorption coefficients measured in this laboratory.

RESULTS

A series of experiments was carried out in the closed cell with low total pressure, 19 to 56 torr. The decay of NO_2 was first-order throughout an experiment, and the results are listed in Table 1. When NO_2 is photolyzed in a closed cell at one atmosphere, the initial decay is first order, but deviations from first-order kinetics appear at later times, as illustrated

by Figure 2 (The concentration of NO_2 was followed by infrared absorption at 1600 cm^{-1}). Data for a series of experiments of this type are included in Table 1.

The build up and decay of N_2O_5 is illustrated by Figure 3 for conditions at one atmosphere total pressure (N_2) and 24°C . The concentration of N_2O_5 was followed by infrared absorption at 1238 cm^{-1} . The initial rate of formation of N_2O_5 is given in Table 2, and the concentrations of NO , NO_2 , and N_2O_5 at the maximum value of N_2O_5 are given in Table 3. A plot of $([\text{N}_2\text{O}_5]/[\text{NO}_2])^*$ against $([\text{NO}_2]/[\text{NO}])^*$ is given as Figure 4, compare Eq. 4.

Along with these conventional measurements, a molecular-modulation study of NO_2 photolysis was carried out. The molecular-modulation method consists of monitoring the periodic concentration fluctuations induced in the reacting species by flashing the photolysis lamps on and off. In this work the NO_2 modulation was studied in a steady flow system with the photolysis lamps flashing at 1 cps. Under these conditions the NO_3 radicals and oxygen atoms will be at their steady state concentrations and N_2O_5 will be equilibrium.

The behavior of the concentration modulation of NO_2 can be described by a differential equation with the flashing lamps represented by the Fourier series for a square wave.

$$\frac{d[\text{NO}_2]}{dt} = \frac{F}{V} \{ [\text{NO}_2]_{\text{in}} - [\text{NO}_2]_{\text{out}} \} - \left(\frac{k_2 [\text{NO}_2]^2}{k_1 [\text{NO}] [\text{M}] + (k_2 + k_3 [\text{M}]) [\text{NO}_2]} \right) \left(\frac{2\alpha I}{\pi} \sum_{\text{odd } n}^{\infty} \frac{1}{n} \sin(n\omega t) + \alpha I \right) \quad (6)$$

With: F = flow rate of chemicals

V = Volume of the reaction cell

$[\text{NO}_2]_{\text{in}}$ = the NO_2 concentration flowing into the cell

$[\text{NO}_2]_{\text{out}}$ = the NO_2 concentration flowing out of the cell

$\omega = 2\pi/T$, where T is the period of the square wave

This equation neglects the ozone reactions, since the system contains no initial oxygen and the O_3 buildup will not be significant. Under these conditions the flow system has reached a steady state with respect to reactants and products, so the un-modulated or DC terms in Eq. 6 cancel leaving only the modulation or AC terms.

$$\frac{d[\text{NO}_2]_{\text{AC}}}{d\theta} = \frac{-\alpha I}{\pi^2 f} \frac{2k_2 [\text{NO}_2]^2 \sum_{\text{odd } n}^{\infty} \frac{1}{n} \sin(n\theta)}{k_1 [\text{NO}] [\text{M}] + (k_2 + k_3 [\text{M}] [\text{NO}_2])} \quad (7)$$

where $d\theta = 2\pi f dt$; $\theta = \omega t$; and f = flashing frequency.

Selecting the conditions so that the modulation will be less than one part per thousand leaves the reactant concentrations essentially constant, allowing Eq. 7 to be integrated in closed form to give:

$$[\text{NO}_2]_{\text{AC}} = \frac{\alpha I [\text{NO}_2]^2}{\pi^2 f} \frac{2k_2 \sum_{\text{odd } n}^{\infty} n^{-2} \cos(n\theta)}{k_1 [\text{NO}] [\text{M}] + (k_2 + k_3 [\text{M}] [\text{NO}_2])} \quad (8)$$

By electronically filtering out all but the first Fourier component of the modulation signal, and taking the peak to peak amplitude gives the experimental relationship:

$$[\text{NO}_2]_{\text{mod}} = \frac{4\alpha I k_2 [\text{NO}_2]^2}{\pi^2 f (k_1 [\text{NO}] [\text{M}] + (k_2 + k_3 [\text{M}]) [\text{NO}_2])} \quad (9)$$

Comparison of Eqs. 8 and 6 shows the NO_2 modulation waveform to be triangular, phase shifted 90° from the exciting light. The amplitude of this waveform and its phase shift from the exciting light can be determined experimentally and related to Eq. 9.

A summary of the steady state concentrations with the phase shift and amplitude measurements are recorded in Table 4. The photolytic light intensity for the modulation experiments was found to be 11.2% greater than in the initial slope experiments, when measured by the phototransistor mounted in the cell, and the values of αI have been normalized by this factor.

DISCUSSION

The observed rate constant ratios are assembled in Table 5. The two independent values of k_3/k_2 agree within 10 per cent; the value based on Eq. 2 was more precise and is preferred. The three observed ratios, k_1/k_2 , k_3/k_2 , and k_4/K , are compared with values reported in the literature in Table 6.

This study gives only rate ratios. To evaluate absolute values of rate constants, either k_1 , k_2 , or k_3 must be taken from the literature. Of the three, the most extensive and most precise data are those for k_1 . Literature values are summarized in Table 7, and the value $6.9 \times 10^{-32} \text{ cm}^3 \text{ molecule}^{-1} \text{ sec}^{-1}$ was taken for N_2 as foreign gas at room temperature. The observed quantity k_4/K is reduced to k_4 by the literature value of K .

With these values of K and k_1 , the elementary rate constants k_2 , k_3 , and k_4 are evaluated and listed in Table 8 with the other 8 elementary rate constants in this system.

With these 8 elementary reactions, a computer program was written that integrated the simultaneous rate equations to give NO_2 and N_2O_5 as a function of time. In Figures 2 and 3 the circles represent observations and the smooth curves are those calculated from the elementary rate constants in Table 8. There is good agreement between the calculated and observed curves over the full course of observations.

ACKNOWLEDGEMENT

This work was supported in part by the U.S. Atomic Energy Commission through the Inorganic Materials Research Division, Lawrence Berkeley Laboratory, and in part by AP-104 Air Pollution Control Office, Environmental Protection Agency.

Table 1. Initial rate of decay of NO_2 as a function of pressure

$[\text{NO}_2]$ molecules cm^{-3}	Total pressure torr	Relative light int.	k_a sec^{-1} Eq. 2
8.6×10^{14}	19.5	1.00	1.47×10^{-2}
8.8×10^{14}	19.5		1.44×10^{-2}
4.8×10^{14}	22		1.50×10^{-2}
8.8×10^{14}	27		1.52×10^{-2}
12×10^{14}	56		1.52×10^{-2}
6.7×10^{14}	756	1.00	1.23×10^{-2}
9.6×10^{14}	756		1.20×10^{-2}
10.5×10^{14}	756		1.25×10^{-2}
11.6×10^{14}	756		1.22×10^{-2}
2.1×10^{14}	756	0.56	0.69×10^{-2}
2.4×10^{14}	756		0.71×10^{-2}
3.1×10^{14}	756		0.68×10^{-2}
19.7×10^{14}	756		0.68×10^{-2}

Temperature 24°C

NO_2 followed by infrared absorption at 1600 cm^{-1}

Table 2. Initial rate of formation of N_2O_5

[NO ₂] molecules cm ⁻³	$\frac{\lim(d[N_2O_5]/dt)_{t \rightarrow 0}}{[NO_2]}$ sec ⁻¹
1.91×10 ¹⁵	0.73×10 ⁻³
2.5×10 ¹⁵	0.69×10 ⁻³
2.6×10 ¹⁵	0.64×10 ⁻³
2.8×10 ¹⁵	0.63×10 ⁻³
3.3×10 ¹⁵	0.70×10 ⁻³
3.3×10 ¹⁵	0.79×10 ⁻³

Table 3. Conditions at maximum concentration of N_2O_5

Initial concentrations		Concentrations at N_2O_5 maximum		
$[NO_2]$ $\times 10^{-15}$	$[NO]$ $\times 10^{-14}$	$[N_2O_5]$ $\times 10^{-13}$	$[NO_2]$ $\times 10^{-15}$	Ratio $\frac{[NO][N_2O_5]}{[NO]^2}$ $\times 10^3$
3.28	0.0	2.1	2.82	1.14
3.26	0.0	2.0	2.79	1.13
2.50	0.0	1.43	2.13	1.06
2.84	0.0	1.66	2.43	1.08
1.85	8.1	0.89	1.59	1.11
1.61	10.2	0.65	1.37	1.11
2.56	16.5	0.84	2.21	0.91
2.56	25.2	0.68	2.19	0.87
2.26	25.8	0.80	1.95	1.16
2.36	40.8	0.57	2.00	1.05

Table 4. Data for NO₂ modulation at one atmosphere total pressure, 24°C

Carrier gas	Steady state concentration [NO ₂] ×10 ⁻¹⁴	[NO] ×10 ⁻¹⁵	k _a sec ⁻¹ ×10 ³	phase shift degrees	Δ[NO ₂] mod. ×10 ⁻¹¹	$\frac{k_1}{k_2}$ [M]
N ₂	1.02	0.74	8.3	93.6	1.43	0.163
N ₂	1.19	1.22	8.3	89	1.31	0.179
N ₂	0.68	1.49	8.3	70	1.40	0.189
N ₂	1.13	2.04	8.3	82	0.83	0.185
N ₂	1.87	2.12	8.3	80	1.62	0.190
N ₂	1.68	1.60	7.2	94	1.68	0.178
Ar	1.55	1.38	8.3	88.2	1.78	0.190
Ar*	2.12	1.30	4.6	87.8	1.65	0.206
Ar	1.34	1.34	8.3	91.8	1.41	0.198

Table 5. Observed rate constant and rate constant ratios

Rate constant function	Observed value	Based on equation	Source of data	Condition
αI	$7.45 \times 10^{-3} \text{ sec}^{-1}$	(1)	Table 1	
k_a	$1.22 \times 10^{-2} \text{ sec}^{-1}$	(2)	Table 1	1 atm N_2
$k_3[M]/k_2$	0.22	(2)	Table 1	1 atm N_2
k_3/k_2	8.9×10^{-21}	(2)		$N_2 = M$
$k_3[M]/k_2$	0.20	(3)	Table 2	1 atm N_2
k_3/k_2	8.1×10^{-21}	(3)		$N_2 = M$
k_4/K	0.71 sec^{-1}	(4)	Table 3, Fig. 4	
$k_1[M]/k_2$	0.18	(5)	Table 4	1 atm N_2
k_1/k_2	7.3×10^{-21}	(5)		$N_2 = M$
$k_1[M]/k_2$	0.20	(5)	Table 4	1 atm Ar
k_1/k_2	8.1×10^{-21}	(5)		Ar = M

Table 6. Comparison of the results of this work with the literature values

$k_1 [M]/k_2$	$k_3 [M]/k_2$	k_4/K (sec^{-1})	T°K	Ref.
0.18±.01	0.221±.005	0.71±.02	296	This work
0.18±.004	0.33±.08		296	7
0.10±.05	0.27±.03		295	5
0.36	1.9		300	4
		0.60±.06	296	8

Total Pressure = 1 Atmosphere
M Gas = Nitrogen

Table 7. Observed values of k_1

k_1 ($\text{cm}^6/\text{molecule}^{-1} \text{sec}^{-1}$)	M gas	T	Ref
$7.0 \pm 0.08 \times 10^{-32}$	$\text{O}_2, \text{N}_2, \text{Ar}$	296	9
$7.6 \pm 0.05 \times 10^{-32}$	Ar, O_2	300	10
$6.4 \pm 0.8 \times 10^{-32}$	O_2	297	11
$7.3 \pm 0.9 \times 10^{-32}$	N_2	297	11
$5.1 \pm 0.2 \times 10^{-32}$	$\text{O}_2, \text{He}, \text{Ar}$	293	12
5.3×10^{-32}	Ar	298	13
6.1×10^{-32}	N_2	298	14
$10.0 \pm 0.14 \times 10^{-32}$	N_2	296	15
Ave. value = $6.9 \times 10^{-32} \text{ cm}^6/\text{molecule-sec}$			

Table 8. Elementary rate constants for nitrogen dioxide photolysis, 297°K, 1 atm N₂

Constant	Value	Source	Ref.
k ₁	6.9×10 ⁻³² cm ⁶ sec ⁻¹	Literature	[9-15]
k ₂	9.2×10 ⁻¹² cm ³ sec ⁻¹	k ₁ , k ₁ /k ₂	Table 5
k ₃	8.2×10 ⁻³² cm ⁶ sec ⁻¹	k ₂ , k ₃ /k ₂	Table 5
K	1.24×10 ⁻¹¹ cm ⁻³	Literature	[16]
k ₄	8.7×10 ⁻¹² cm ³ sec ⁻¹	K, k ₄ /K	Table 5
k _{6M}	0.104 sec ⁻¹	Literature	[17]
k _{5M}	1.29×10 ⁻¹² cm ³ sec ⁻¹	K, k _{6M}	
k ₇	6.24×10 ⁻³⁴ cm ⁻⁶ sec ⁻¹	Literature	[18]
k ₈	2.1×10 ⁻¹⁴ cm ³ sec ⁻¹	Literature	[19]

REFERENCES

1. A.J. Hagen-Smit, *Ind. Eng. Chem.* 44, 1342 (1952).
2. a. M. Nicolet, *J. Geophys. Res.* 70, 679 (1965).
b. P.J. Crutzen, *Quart. J. Roy. Met. Soc.* 96, 320 (1970).
c. H.S. Johnston, *Science* 173, 517 (1971).
3. T.C. Hall, Jr., "Photochemical Studies of Nitrogen Dioxide and Sulfur Dioxide", Doctoral Thesis, University of California, Los Angeles.
4. H.W. Ford and N. Endow, *J. Chem. Phys.* 27, 1156, 1277 (1957).
5. J. Troe, *Ber. Bunsenges. Physik Chem.* 73, 906 (1969).
6. H.S. Johnston, G.E. McGraw, T.T. Paukert, L.W. Richards, and J. Van den Bogaerde, *Proc. National Academy of Sciences* 57, 1146 (1967).
7. E.A. Schuck, E.R. Stephens, and R.R. Schrock, *J. Air Pollution Control Ass.* 16, 695 (1966).
8. I.C. Hisatsune, B. Crawford, Jr., and R.A. Ogg, Jr., *J. Am. Chem. Soc.* 79, 4648 (1957).
9. F. Kaufman, *Proc. Roy. Soc.* A247, 123 (1958).
10. P. Hastek, R.R. Reeves, and G.G. Mannella, Air Force Cambridge Research Center, Technical Report, AFCRC-TR60-264 (1960).
11. M.A.A. Clyne and B.A. Thrush, *Proc. Roy. Soc.* A269, 404 (1962).
12. E.A. Ogryzlo and H.I. Schiff, *Can. J. Chem.* 37, 1690 (1959).
13. S. Takahashi and S. Miyazaki, *Mem. Def. Acad., Jap.* 8, 611 (1968).
14. S. Takahashi, *Mem. Def. Acad., Jap.* 8, 777 (1968).

15. F.S. Klein and J.T. Herron, J. Chem. Phys. 41, 1285 (1964).
16. G. Schott and N. Davidson, J. Am. Chem. Soc. 80, 1841 (1958).
17. R.L. Mills and H.S. Johnston, J. Am. Chem. Soc. 73, 938 (1951).
18. H.S. Johnston, "Gas Phase Reaction Kinetics of Neutral Oxygen Species", NSRDS-National Bureau of Standards. 20.
19. H.S. Johnston and H.J. Crosby, J. Chem. Phys. 22, 689 (1954).

TITLES TO FIGURES

- Fig. 1. Schematic diagram of experimental apparatus.
- Fig. 2. NO_2 decay; comparison of experimental points and calculated curve based on rate constants in Table 8. Initial concentrations: $[\text{NO}_2] = 4.2 \times 10^{15}$, $[\text{NO}] = 2.05 \times 10^{14}$.
- Fig. 3. N_2O_5 decay as observed by infrared absorption at 1237 cm^{-1} ; comparison of experimental points and calculated curve based on rate constants in Table 8. Initial concentrations: $\text{NO}_2 = 2.8 \times 10^{15} \text{ molecules cm}^{-3}$, $[\text{NO}] = 0$.
- Fig. 4. Concentration ratios where nitrogen pentoxide is a maximum, Equation 4.

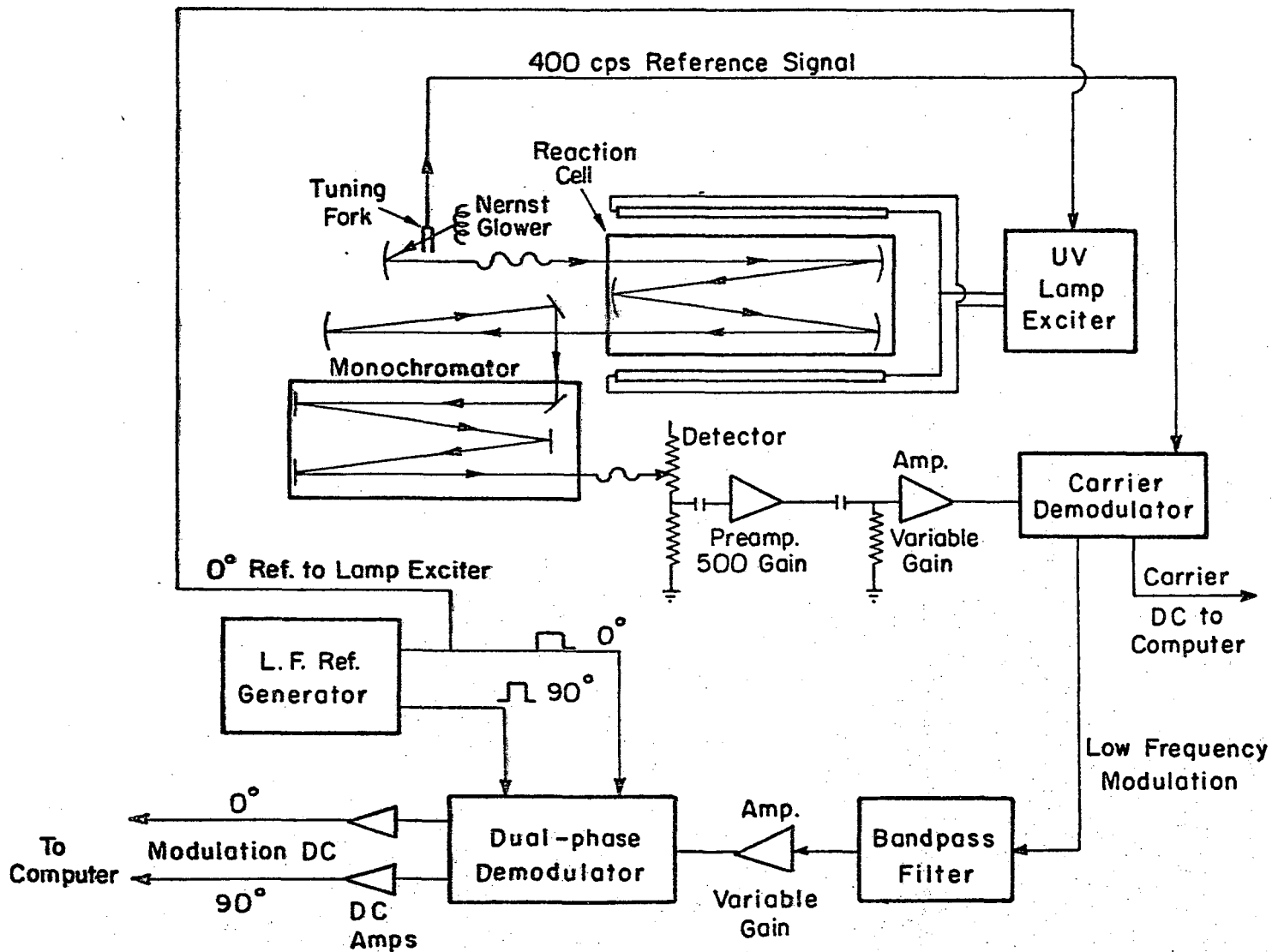

XBL 728-6830

Fig. 1

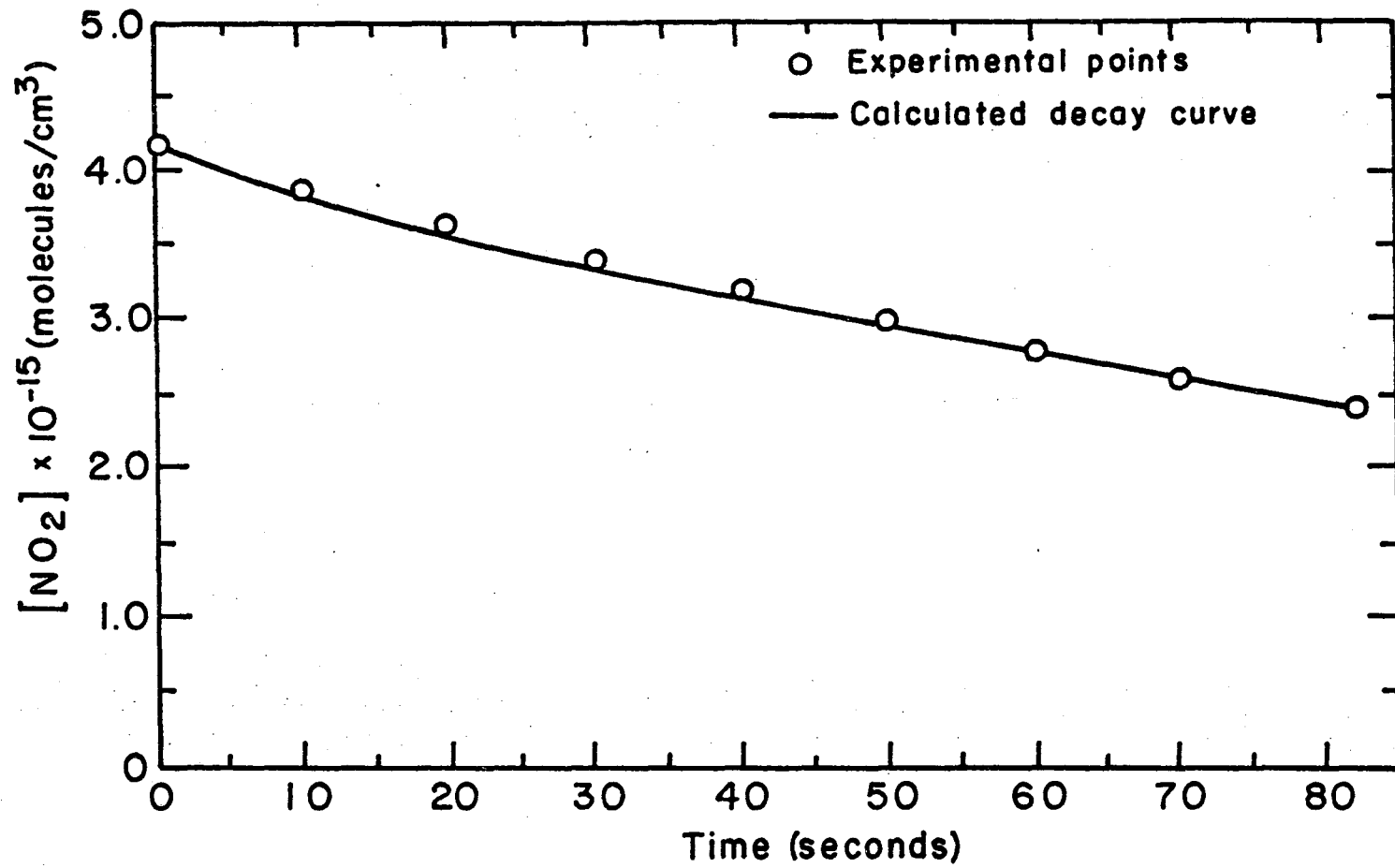
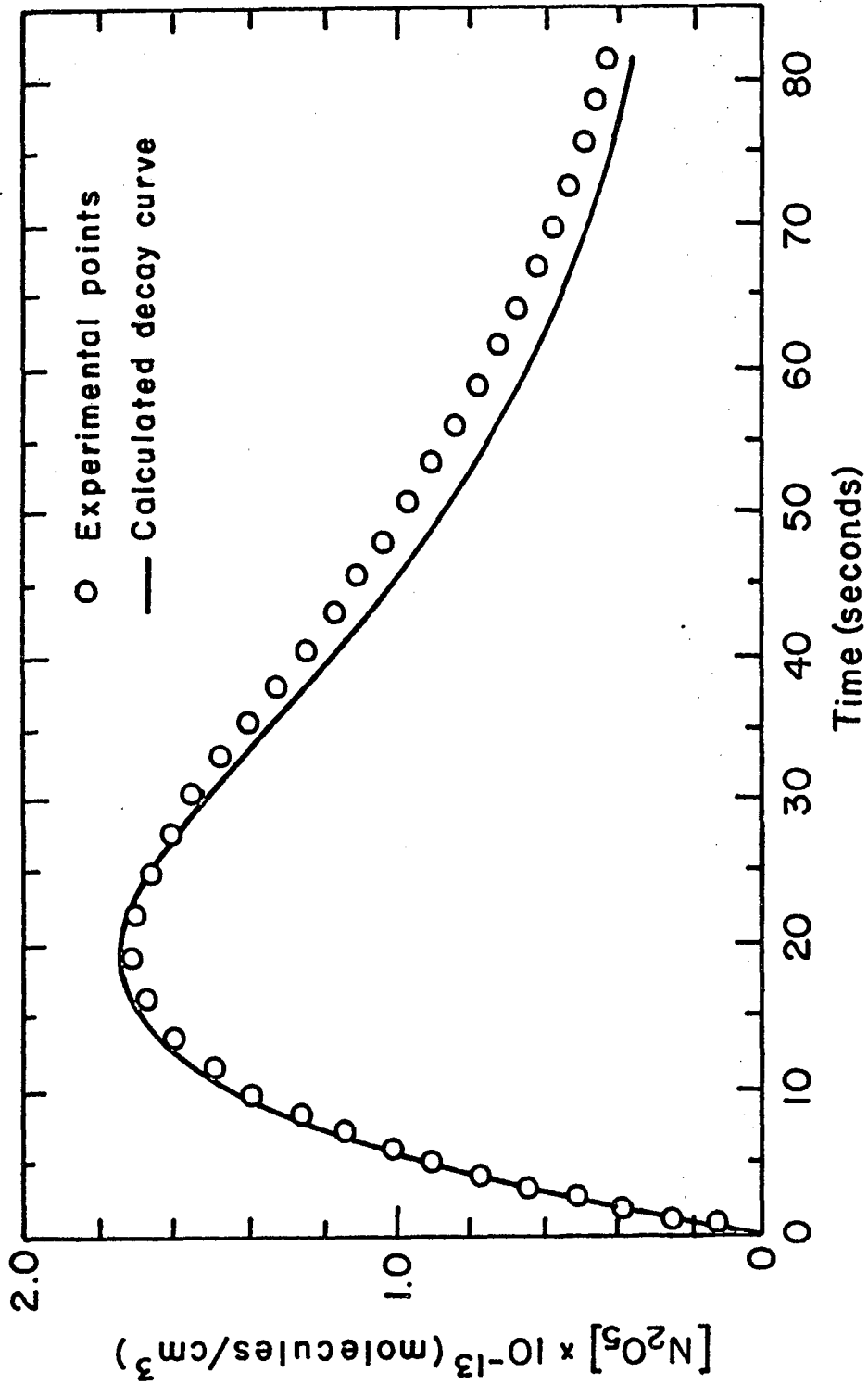

Fig. 2

XBL728-6843



XBL728-6845

Fig. 3

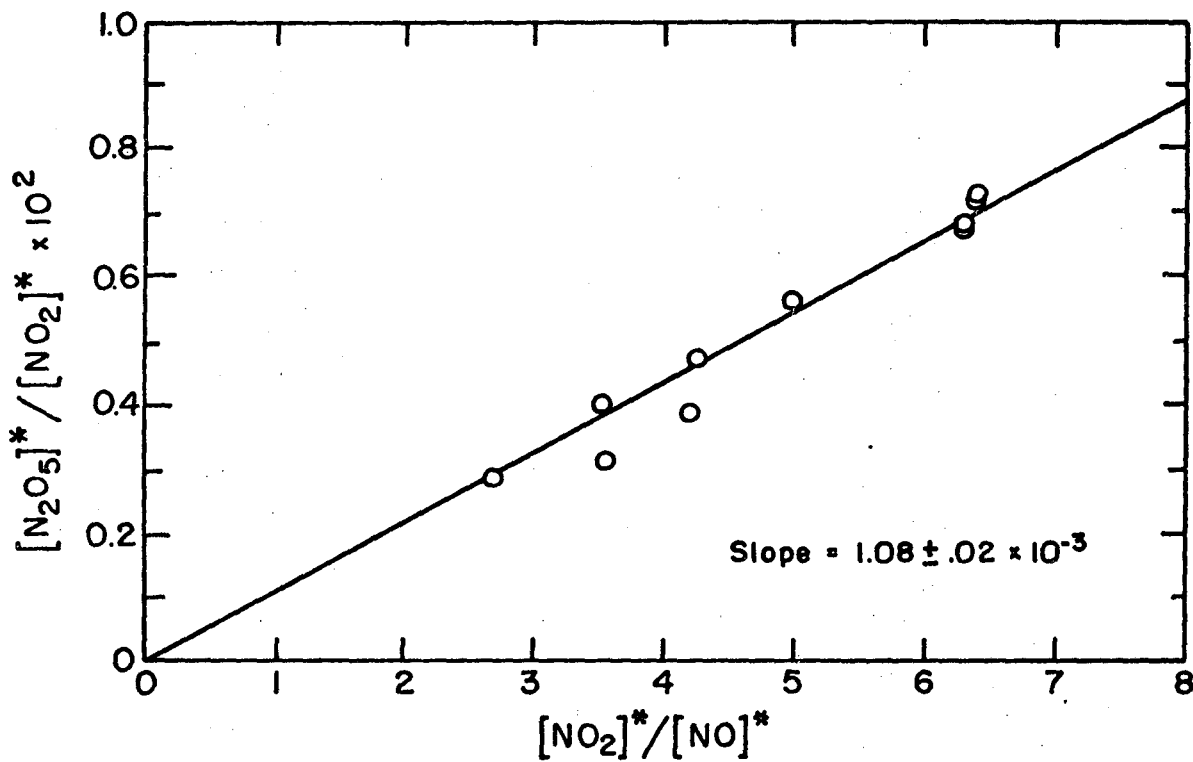

The * indicates the concentration at the time of the N_2O_5 concentration maximum, t^*

XBL 728-6842

Fig. 4

LEGAL NOTICE

This report was prepared as an account of work sponsored by the United States Government. Neither the United States nor the United States Atomic Energy Commission, nor any of their employees, nor any of their contractors, subcontractors, or their employees, makes any warranty, express or implied, or assumes any legal liability or responsibility for the accuracy, completeness or usefulness of any information, apparatus, product or process disclosed, or represents that its use would not infringe privately owned rights.

TECHNICAL INFORMATION DIVISION
LAWRENCE BERKELEY LABORATORY
UNIVERSITY OF CALIFORNIA
BERKELEY, CALIFORNIA 94720