

Lawrence Berkeley National Laboratory

Recent Work

Title

RADIATIVE LIFETIME OF METASTABLE $^{23}\text{S}1 \text{ Li}^+$

Permalink

<https://escholarship.org/uc/item/8b6781x5>

Author

Knight, R.D.

Publication Date

1979-08-01



Lawrence Berkeley Laboratory

UNIVERSITY OF CALIFORNIA

Materials & Molecular Research Division

Submitted to Physical Review A

RADIATIVE LIFETIME OF METASTABLE 2^3S_1Li^+

R. D. Knight and M. H. Prior

August 1979

RECEIVED
LAWRENCE
BERKELEY LABORATORY

SEP 28 1979

LIBRARY AND
DOCUMENTS SECTION

TWO-WEEK LOAN COPY

*This is a Library Circulating Copy
which may be borrowed for two weeks.
For a personal retention copy, call
Tech. Info. Division, Ext. 6782*

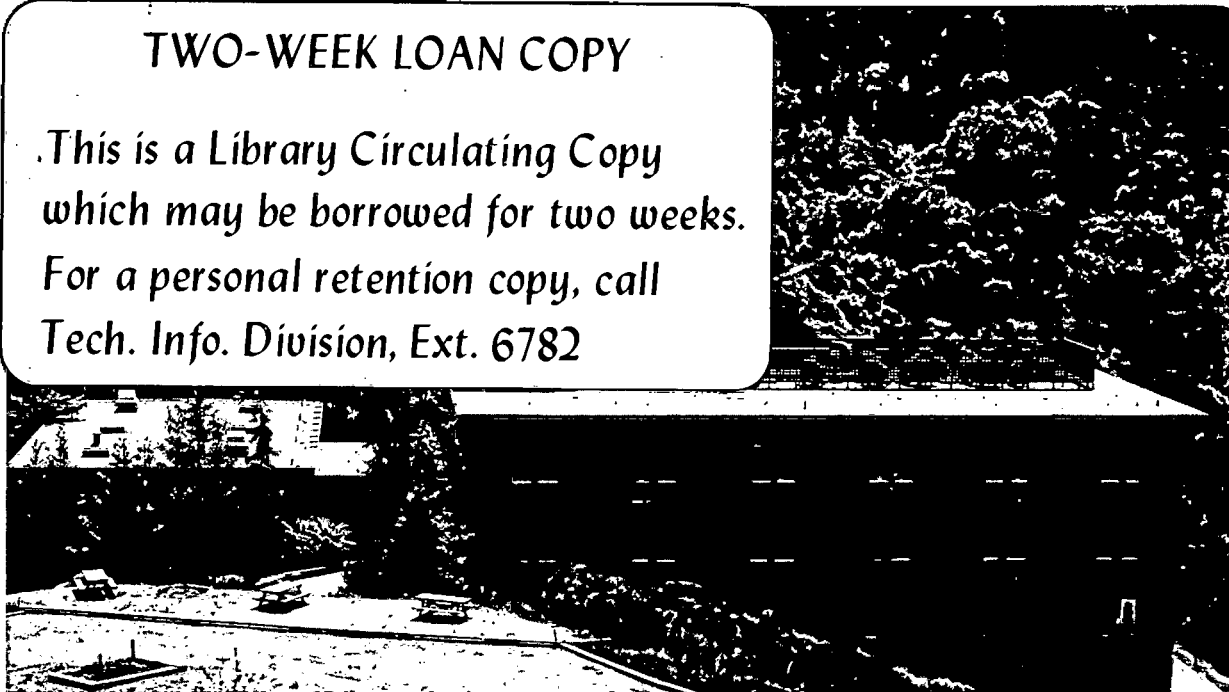

LBL-9757 c. 2

DISCLAIMER

This document was prepared as an account of work sponsored by the United States Government. While this document is believed to contain correct information, neither the United States Government nor any agency thereof, nor the Regents of the University of California, nor any of their employees, makes any warranty, express or implied, or assumes any legal responsibility for the accuracy, completeness, or usefulness of any information, apparatus, product, or process disclosed, or represents that its use would not infringe privately owned rights. Reference herein to any specific commercial product, process, or service by its trade name, trademark, manufacturer, or otherwise, does not necessarily constitute or imply its endorsement, recommendation, or favoring by the United States Government or any agency thereof, or the Regents of the University of California. The views and opinions of authors expressed herein do not necessarily state or reflect those of the United States Government or any agency thereof or the Regents of the University of California.

Radiative Lifetime of Metastable 2^3S_1 Li^+ *

R. D. Knight** and M. H. Prior

University of California

Department of Physics

and

Lawrence Berkeley Laboratory

Berkeley, California 94720

ABSTRACT

The radiative lifetime of $1s2s$ 3S_1 Li^+ ions has been measured by a comparison of the count rate of spontaneous decay photons (210\AA) to a laser induced fluorescence signal proportional to the total number of metastable ions. The ions were confined in a rf-quadrupole trap, and the fluorescence signal used was the intercombination transition $1s2p$ 3P_1 to $1s^2$ 1S_0 at 202\AA . The 3P_1 state was populated from 3S_1 by absorption of laser photons at 5485\AA . The result is $\tau_r = 58.6 \pm 12.9$ sec (95% confidence level); theory predicts $\tau_r = 49.1$ sec.

I. INTRODUCTION

The two-electron atom is one of the simplest systems in atomic physics. Understanding of such systems can be gauged by the remarkable precision with which the energy levels and other properties can be calculated. It is quite surprising, then, that the correct decay mode of the lowest excited state ($1s2s\ ^3S_1$) was not discovered until 1969. In that year, Gabriel and Jordan¹ reported the observation of emission lines in the solar X-ray spectrum which they attributed to single-photon decay of this state in various helium-like ions. For nearly 30 years prior to this, the 2^3S_1 decay mode had been considered, based on work by Breit and Teller², to be two-photon emission.

Numerous studies of the 2^3S_1 state have occurred since the discovery of single-photon decay. Theoretical work by Griem³, followed by the more detailed calculations of Drake⁴ and Johnson and Lin⁵, verified that single-photon relativistic magnetic dipole (M1) decay is the dominant mechanism. A non-zero transition rate arises from the "finite wavelength" corrections to the M1 operator and can be calculated in the second Pauli approximation. A measurement of the M1 decay rate has been reported for He by Woodworth and Moos⁶, and several investigators⁷ have made lifetime measurements using the beam-foil time-of-flight technique on two-electron ions with Z in the range $16 \leq Z \leq 36$.

Since the transition rate scales as Z^{10} , the lifetimes measured span nearly 14 orders of magnitude (8000 sec at $Z=2$ down to .2 nsec at $Z=36$). The agreement of theory and experiment over this exceptionally large range is generally satisfactory. However, the beam-foil experiments⁷ observe an apparent non-exponential decay of 2^3S_1 for times less than ≈ 1 theoretical lifetime; only when the detector is >1 mean decay length downstream from the foil do the measured decay curves approach single exponential character with lifetimes in agreement with theoretical values. For shorter foil-detector separations the apparent decay rate is anomalously fast. This behavior is not yet understood, although Lin and Armstrong⁸ have suggested

an explanation based on the assumed presence of a three electron ion component in the beam. The possibility of additional processes affecting the decay of the 2^3S_1 state has not been ruled out. Because of the importance of this transition in astrophysics⁹, possibly as a diagnostic for laboratory plasmas, and as a general test of our understanding of two-electron atoms, a lifetime measurement at $Z=3$ by a completely different technique was judged to be useful.

In this paper we report a measurement of the radiative lifetime of 2^3S_1 in Li^+ ions which are stored for many seconds in an ion trap. The theoretical value⁴ for the lifetime is 49.0 sec. We determine the lifetime by a comparison of spontaneous M1 decay at 210\AA to the intercombination $2^3P_1 - 1^1S_0$ decay (202\AA) following $2^3S_1 - 2^3P_1$ excitation at 5485\AA with a dye laser. After discussing the methods and results of our experiment, our measured value is compared with theory and previous measurements.

II. LIFETIME MEASUREMENT PROCEDURES

In principle, measurement of the metastable lifetime is very straightforward; simply create Li^+ ions, some of which are in the 2^3S_1 state, in the ion trap and monitor the metastable population as a function of time. Many difficulties conspire to destroy this simplicity, including imperfect ion storage, poor signal-to-noise for detecting spontaneous emission, and, most important, nonradiative quenching of the metastables. These problems prevented us from determining the radiative lifetime by measuring spontaneous decay curves and led to the adoption of the spontaneous emission - intercombination line comparison described in this section.

To determine the time dependence of the metastable state, one can either observe the decay process (spontaneously emitted photons) or observe the number of undecayed metastable ions. Nonradiative quenching of the metastable state, discussed below, forced us to choose the latter method. The Li^+ energy levels relevant to this work are shown in Figure 1. A cw-dye laser at 5485\AA excites the $2^3S_1 - 2^3P_1$ transition. Relativistic effects, such as the spin-orbit interaction, mix 2^3P_1 with n^1P_1 states¹⁰ and result in a branching ratio of $\approx 1:1200$ for an

intercombination $2^3P_1 - 1^1S_0$ decay (202\AA) versus decay back to 2^3S_1 . With a typical laser power ~ 50 mW, the entire metastable population is depleted in a time $\tau_l \approx .3$ sec, much less than the total metastable lifetime (determined primarily by nonradiative quenching) $\tau_m \approx 5$ sec at an operating pressure of 10^{-9} torr. Thus each metastable ion is forced to emit a detectable 202\AA photon in a time period τ_l , and since $\tau_l \ll \tau_m$, the number of photons counted is proportional to the number of metastables existing at the time when the laser is turned on. By varying the delay between creation and detection, the metastable time dependence is measured. Since the spontaneous emission count rate is roughly the same as the detector dark rate (~ 10 counts per minute), the ability to compress all photon counts into the short time period τ_l considerably enhances the signal-to-noise over the alternative method of measuring the time dependence by observing spontaneous decay. A typical set of data is shown in Figure 2, where the photon counts are collected in .1 sec wide bins. In this case spontaneous photons are counted for 1.0 sec, the laser beam is turned on at $t = 1.0$ sec, and laser induced depletion is then observed. The first channel after the laser comes on is artificially low due to the time required ($\approx 20\%$ of a channel) to open the mechanical shutter which passes the laser beam.

By using this laser depletion technique, we established that the metastable population decays exponentially. A typical decay, using 1 sec wide bins, is shown in Figure 3, where the signal was followed for more than 3 lifetimes. The decay time also agrees well with decay times determined, under similar conditions, from spontaneous emission, though the poor signal-to-noise of the spontaneous decay signal requires substantially longer collection periods to achieve comparable precision. From a comparison of metastable ion decay curves collected both ways and measurement of the decay of the total stored charge, two important facts emerged. First, the metastable lifetime τ_m was much less than the ion storage lifetime. At a residual pressure $\approx 1 \times 10^{-9}$ torr, $\tau_m \approx 5$ sec whereas the ion storage lifetime was typically 20 sec. Second, the integrated number of spontaneous counts was smaller, by roughly a factor of ten, than the integrated number of laser induced counts. This is far too much to explain merely through storage losses and differences in detection efficiencies. The most reasonable explanation for

these observations is nonradiative quenching of the metastable ions by collisions with background gas molecules. This could cause most metastable ions to be lost without emitting a photon, so the integrated spontaneous count rate would be substantially less than if spontaneous emission were the only loss process.

Further information concerning the apparent quenching was obtained by measuring the number of ions stored with and without the laser on. With the laser on continuously, metastable ions are forced into the ground state very shortly after creation, and all ground state ions exhibit the same storage loss rate. Without the laser, however, the faster loss rate of metastable ions could conceivably be to a neutral state, via charge capture, which would be lost from the trap. In that case, comparison at time $t = \tau_m$ of the number of stored ions with and without the laser would show a difference. The metastable fraction is estimated, based on counting rates and detector efficiencies, to be $\approx 10\%$. No difference in the ion number was found, to an accuracy of 1%. This is consistent with a quenching process of the form

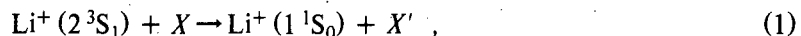

where X' is related to X through a process such as Penning ionization, dissociation, or near-resonant charge capture to an autoionizing Li ($1s 2s np$) state¹¹ which decays to $\text{Li}^+ (1^1S_0) + e^-$ in $\leq 1 \mu\text{sec}$ (before the neutral can escape from the trap).

Additional tests to verify that the metastable loss was due to collisional quenching were made by varying the background gas composition and density. A residual gas analyzer showed the principle components of the background gas to be H_2 , CH_4 , H_2O , CO , and CO_2 . The metastable loss rate, τ_m^{-1} , as a function of relative pressure was measured for all of these except H_2O . Results for H_2 and CH_4 are shown in Figure 4; CO and CO_2 behaved similarly. It was also observed that the ion storage time was independent of H_2 and CH_4 pressure over the range covered, and changed less rapidly than the metastable lifetime as the CO and CO_2 pressures were varied. This indicated the existence of a mechanism causing the preferential loss of metastable ions. The collisional quenching cross sections were not determined since the residual gas analyzer was not absolutely calibrated, but comparison with ion gauge readings and

typical ionization efficiencies allowed an estimate of $\approx 10^{-14}$ cm² for the cross sections. These are not unreasonable for the processes mentioned above.

Summarizing these observations: (1) The metastable loss rate was exponential and faster than the ion loss rate from the trap; (2) Most of the metastable loss was not by the emission of a photon; (3) Most, probably all, of the metastable loss was to the ionic ground state; (4) The metastable loss rate was a sensitive function of the residual gas pressure and composition. We concluded that the metastable time dependence could be explained by a combination of storage losses, spontaneous decay, and nonradiative quenching collisions.

To determine the rate of radiative decay only, the following scheme was used. One notes that, at any instant of time, the rate $\frac{dS}{dt}$ at which photons are emitted is related to the number N of metastables by

$$\frac{dS(t)}{dt} = \frac{N(t)}{\tau_r} \quad (2)$$

independent of any nonradiative losses which may also be occurring. A simultaneous measurement of $\frac{dS}{dt}$ and N would allow the radiative lifetime τ_r to be determined. This is essentially the method used by Woodworth and Moos⁶ in He. While a simultaneous and instantaneous measurement is not experimentally feasible, a sufficiently good approximation can be made. Consider the case where, following ion creation, a total S_1 of spontaneous M1 photons are counted for a time T_1 , after which the laser is turned on and a total of S_2 spontaneous plus laser induced photons are counted in a time interval T_2 during which all the metastables are depleted. Then for T_1 sufficiently small, and assuming no difference in detector efficiencies for the two photon wavelengths, one has simply,

$$\tau_r = \frac{S_2}{S_1} T_1 \quad (3)$$

A more realistic expression is obtained from a detailed consideration of the several competing loss processes. Let the various loss rates be $\gamma_r = \tau_r^{-1}$ = the radiative decay rate, $\gamma_q = \tau_q^{-1}$ = the nonradiative loss rate, and $\gamma_l = \tau_l^{-1}$ = the laser depletion loss rate. While the

laser is off, the total metastable decay rate, γ_m , is given by

$$\gamma_m = \gamma_r + \gamma_q \quad (4)$$

while with the laser on, the total depletion rate γ_d is

$$\gamma_d = \gamma_r + \gamma_q + \gamma_l \quad (5)$$

A measurement of the 2^3S_1 population time dependence, such as shown in Figure 3, gives γ_m .

A least squares analysis of the depletion itself, as in Figure 2, gives $\gamma_d = \tau_d^{-1}$. One can write the rate equations for counting photons during time periods T_1 (laser off) and T_2 (laser on), respectively, as

$$\frac{dS_1}{dt} = \epsilon_{210}\gamma_r N_0 e^{-\gamma_m t} \quad (6)$$

$$\frac{dS_2}{dt} = (\epsilon_{210}\gamma_r + \epsilon_{202}\gamma_l) N_0 e^{-\gamma_m T_1} e^{-\gamma_d t'} \quad (7)$$

where ϵ_{210} and ϵ_{202} are the efficiencies for counting the 210Å spontaneous photons and the 202Å laser induced photons, N_0 is the initial number of metastable ions, and $t' = t - T_1$. During T_2 we have included both spontaneous and laser induced decay. These equations are easily integrated to give S_1 and S_2 , the number of photons counted in T_1 and T_2 . Eliminating N_0 and solving for the radiative lifetime yields

$$\tau_r = \frac{\epsilon_{210}}{\epsilon_{202}} \frac{\tau_m^2}{(\tau_m - \tau_d)} \left[(e^{\gamma_m T_1} - 1) \frac{S_2'}{S_1} - \frac{\tau_d}{\tau_m} \right], \quad (8)$$

where

$$S_2' = \frac{S_2}{1 - e^{-\gamma_d T_2}} \quad (9)$$

is the number of photons which would be counted if $T_2 \rightarrow \infty$. A small correction ($\leq 1\%$) is made to S_2' to account for the finite time (≈ 20 msec) at the beginning of T_2 needed for the mechanical laser beam shutter to open.

Equation (8) for the radiative lifetime of the 2^3S_1 state depends only on measurable quantities and explicitly takes account of the nonradiative loss of the metastable ions. The following section describes the experimental details of measuring the needed quantities.

III. EXPERIMENTAL METHOD

A basic requirement of this work is the ability to confine ions for many seconds in a volume from which decay photons may be collected, and which is accessible to the laser beam. This is accomplished with an rf-quadrupole ion trap^{12,13}, consisting of two end cap electrodes and a ring electrode which are hyperboloids of revolution. A potential

$$U = U_0 - V_0 \cos \Omega t \quad (10)$$

is applied to the ring electrode. The equations of motion in the axial and radial directions are then Mathieu equations, and for a given ion charge to mass ratio, the motion is bounded for appropriate choices of U_0 , V_0 , and Ω . The ion motion (time averaged over a few rf periods) can be described by an effective harmonic potential

$$\phi_{eff} = \frac{r^2}{r_0^2} D_r + \frac{z^2}{z_0^2} D_z \quad (11)$$

where r_0 and z_0 are the inside radius of the ring electrode and half the spacing of the cap electrodes respectively. D_r and D_z are the potential well depths. In most cases, the trap was operated with a spherical potential well: $D_r = D_z = D$.

A block diagram of the experiment is shown in Figure 5. The Li^+ ions are created by electron impact on a lithium atomic beam which passes through the center of the trap. Passage of the beam is controlled by a solenoid actuated beam flag. A 1/4 inch diameter dispenser cathode mounted axially 2 to 3 mm behind a wire grid in the surface of the lower endcap provides an electron beam current of about 30 microamperes. A one second long filling period produces a maximum ion number of $\approx 2 \times 10^5$. A residual gas pressure $\approx 1 \times 10^{-9}$ Torr allows the ions to be stored with a mean lifetime of ≈ 20 sec and a nonradiative collisional quenching

time for the metastables $\tau_m \approx 5$ sec.

The trap itself has dimensions $r_0 = z_0 = 3.0$ cm. The end cap electrodes are accurately machined OFHC copper, while the ring electrode is a copper wire mesh, formed on a template, which allows good optical access to the trap interior. The rf voltage is at frequency $\Omega = 2\pi \times 1.0$ MHz and amplitude $V_0 = 250$ -400 volts. A DC bias $U_0 = 0$ -30 volts is used to produce spherical potential wells in the range $8 \leq D \leq 18$ volts.

A sideband excitation/resonant detection method is used to monitor the number of stored ions¹². The ion axial motion in the potential well ϕ_{eff} is harmonic at frequency ω_z ; superimposed upon this is a small amplitude micromotion at the rf drive frequency $\Omega \gg \omega_z$. A spectral decomposition of the total motion thus contains frequencies $\Omega \pm \omega_z$ as well as ω_z . Excitation at the sideband frequency $\Omega + \omega_z$ causes the entire ion cloud to oscillate coherently at frequency ω_z . In practice, the excitation frequency is fixed at $\Omega + \omega$ and a DC ramp voltage applied to the ring electrode sweeps the ion frequency ω_z through resonance with $\omega = 2\pi \times 100$ kHz. A tuned amplifier detects the ion cloud oscillation at ω and produces an output signal proportional to the number of ions. The signal height is automatically recorded by a peak detector circuit, digitized, and stored in the computer.

A study of the ion distribution was useful for understanding the details of the ion cloud/laser beam interaction. This was done by measuring the $2^3P_1 - 1^1S_0$ intercombination signal as a function of the laser beam position as it was rapidly scanned across the ion cloud¹⁴. The results of these measurements showed that the metastable ions in spherical wells $8 \leq D \leq 18$ eV have a Gaussian density distribution

$$n = n_0 e^{-\left(\frac{r}{\delta}\right)^2}$$

with $\delta \approx 0.6$ cm. This is consistent with a Maxwellian distribution of ion energies with a temperature of ≈ 5000 degrees K.

The laser is a cw dye laser using rhodamine 110 dye; when tuned with a three element birefringent filter alone the laser has a line width $\delta\lambda \approx 0.2\text{\AA}$. Installation of a 200 GHz free

spectral range etalon in the laser cavity reduces the linewidth to $\approx 0.02\text{\AA}$, allows fine tuning, and greatly improves the wavelength stability. Output power under these conditions is typically 50 - 100 mW. The wavelength is monitored by scanning a portion of the beam across an external etalon and displaying the transmitted intensity, detected by a photodiode, on an oscilloscope. Stability during a one hour data collecting period was generally better than $\pm 0.01\text{\AA}$; variations of this size do not affect the measurement of τ_r . The laser beam is directed perpendicular to the z-axis in the trap midplane. Before entering the vacuum chamber, the linearly polarized laser beam passes through a polarization rotator which establishes the desired polarization orientation with respect to the trap z axis. An optional telescope can expand the beam from its normal diameter of ≈ 1 mm up to ≈ 4 cm.

XUV photons are detected by two EMI venetian blind electron multipliers located 180 degrees apart in the trap horizontal midplane. Grazing incidence light pipes, coated with 200 \AA thick platinum, are located in front of the detectors and improve the photon collection by an estimated factor of ≈ 7.5 . An 800 \AA thick, one inch diameter aluminum foil filter is also located directly in front of the first dynode of each multiplier to prevent escaping ions or metastable neutrals from being counted. Transmission of the foils is $\approx 65\%$ for photons of wavelength 200 \AA ¹⁵. The detector output pulses are amplified, passed through a discriminator, and accumulated by the computer. Adjustment for optimal signal-to-noise leaves a residual dark rate from the two detectors combined of ≈ 10 counts/minute.

An important parameter of the detectors is the relative efficiency factor $\frac{\epsilon_{202}}{\epsilon_{210}}$. This was measured by comparing our detectors, with aluminum foils in place, to an absolutely calibrated channeltron electron multiplier¹⁶. A Ne discharge source and a 2.47 meter VUV grazing incidence monochromator provided nine peaks in the wavelength range 196 \AA - 228 \AA which were used for the calibration. While the absolute efficiency of the channeltron has a 13% uncertainty, the relative efficiency at two wavelengths in this range, the only factor needed in this work, was conservatively estimated to have a 4% uncertainty. Combined with a 3% meas-

urement error and a 3% error from a least squares analysis, the total error in our determination of $\frac{\epsilon_{202}}{\epsilon_{210}}$ is estimated to be 6%. (Both detectors were calibrated separately and produced the same result.) The value obtained was $\frac{\epsilon_{202}}{\epsilon_{210}} = 0.87 \pm 0.05$, where the error is one standard deviation.

The control and data collecting for the entire experiment was performed by a PDP-11 computer. For the purpose of storing data, the computer functions essentially as a multichannel analyzer. The timebase used during data collection was a 60 Hz line clock. Additionally, the computer monitors whether the laser is tuned to the center of the $2^3S_1 - 2^3P_1$ resonance; any decrease in the integrated laser induced photon counts, normalized to the number of ions, is noted on the teletype and allows fine tuning of the laser wavelength. Either upon operator command or when a pre-set number of cycles is completed, the computer prints the data and branches to an analysis program.

According to Eq. 8, the quantities needed to determine τ_r are S_1 , S_2 , τ_d , and τ_m . These are found in a three stage process. First, τ_m is measured using the laser depletion technique, as shown in Figure 3, with several different delays between the trap filling and the laser beam shutter opening. A least squares fit of an exponential decay to this data yields τ_m and $\sigma(\tau_m)$, its standard deviation. Second, data is collected in the manner shown in Figure 2 in order to determine S_1 from the spontaneous counts and S_2 and τ_d from the laser induced counts. A study of the signal-to-noise obtained in a given time period indicated that optimally $T_1 \approx \frac{\tau_m}{2}$ and that T_2 should be several times τ_d in order to have the laser depletion proceed to completion. Most data were taken with $T_1 = 2.0$ sec and $T_2 \approx 5 \cdot \tau_d \approx 2$ sec. The data analysis program returns τ_d and $\sigma(\tau_d)$ from a least squares analysis as well as S_1 and S_2 , defined in Eq. 9. Third, τ_m is remeasured as in the first step and the two values are averaged to obtain a best estimate for its value during the measurement of S_1 , S_2 , and τ_d . Finally, $\tau = \frac{\epsilon_{202}}{\epsilon_{210}} \tau_r$ is computed using Eq. 8. The values of $\sigma(\tau_m)$ and $\sigma(\tau_d)$, returned from the least

squares programs, along with statistical uncertainties for S_1 and S_2 are used to calculate the standard deviation $\sigma(\tau)$ of τ . The entire process typically takes about an hour to achieve a 10% measurement.

IV. RESULTS

Data were collected separately for the isotopes ${}^6\text{Li}^+$ and ${}^7\text{Li}^+$. The sample of ${}^7\text{Li}$ was $>99.9\%$ ${}^7\text{Li}$, but the ${}^6\text{Li}$ was in fact 95.6% ${}^6\text{Li}$ and 4.4% ${}^7\text{Li}$. Thus when studying ${}^6\text{Li}^+$, the small number of ${}^7\text{Li}^+$ ions contribute to the spontaneous photons but not to the laser-induced photons, since the $2^3\text{S}_1 - 2^3\text{P}_1$ transition in ${}^7\text{Li}^+$ is isotopically shifted away from the ${}^6\text{Li}^+$ transition to which the laser was tuned. This requires a correction

$$\tau({}^6\text{Li}^+\text{corrected}) = 1.046 \times \tau({}^6\text{Li}^+\text{uncorrected}).$$

The weighted averages, isotopically corrected, of 26 runs for ${}^6\text{Li}^+$ and 33 runs for ${}^7\text{Li}^+$, without the detector efficiency factor, are

$$\tau({}^6\text{Li}^+) = 49.9 \pm 1.0 \text{ sec} \quad \tau({}^7\text{Li}^+) = 52.0 \pm .9 \text{ sec.} \quad (13)$$

The errors quoted here are 1σ errors of the mean representing only the statistical error involved in determining τ . Possible systematic errors are discussed below. The spread of the measurements is indicated by the standard deviations of the distributions of data: $\sigma({}^6\text{Li}^+) = 4.2 \text{ sec}$ and $\sigma({}^7\text{Li}^+) = 5.1 \text{ sec}$.

One potential source of systematic error arose from the background subtraction method. The measurements of S_2 , τ_d , and τ_m are not particularly sensitive to the background subtraction since the laser-induced count rate was considerably higher than the background. The spontaneous photon rate, on the other hand, was roughly the same as the background rate, so errors in the background subtraction procedure could seriously effect S_1 . Two methods were studied. In the first, a background cycle identical to each data cycle was taken except that the ion trap DC potential was switched very negative during the fill period in order not to store Li^+ ions. The second method differed in that Li^+ ions were excluded simply by not opening the

lithium beam flag during the fill period; the DC trap voltage was held constant. An analysis of data collected by these two methods indicated a possible variation of $\approx 2\%$ in the final value for τ_r . The second method was judged preferable, both because it stores any background gas ions which are usually stored during the data cycle, and because the first method causes slightly different electron trajectories during the fill period that might alter any charging of detector surfaces. All data used in the weighted averages utilized the second method, and a possible systematic error of 2% is assigned.

A general search for systematic errors covered numerous possibilities. The residual gas composition and pressure were varied; this should not affect the result if the analysis leading up to Equation 8 is correct. We admitted H_2 , CH_4 , H_2O , CO , and air through a leak valve and measured τ_r as the partial pressure of each was varied up to at least 10 times its base value. No effect on τ_r was observed. The storage loss rate, the total metastable loss rate, and the radiative rate as a function of CO pressure are shown in Figure 6. Data for the other gases were similar.

A possible source of excess counts which would not be compensated for during the background cycle is the presence of small holes in the aluminum foil filters. This possibility was checked by looking for counts above the background long after the metastable population had been laser-depleted but before many ground state ions had been lost. The integrity of the foils remained good throughout the five month period in which data were accumulated.

Since the ion trap is somewhat mass selective, the percentage of ${}^7Li^+$ ions stored during the ${}^6Li^+$ runs may not have been the same as its 4.4% composition in the bulk lithium. An ion signal from the ${}^7Li^+$ was seen, using the electronic detection discussed in Section III, but was too noisy to compare quantitatively with the ${}^6Li^+$ signal. We estimate the error in $\tau_r({}^6Li^+)$ from this source to be $\leq 2\%$. A possible error in $\tau_r({}^7Li^+)$ only occurs due to the fact that most of the ${}^7Li^+$ data were taken without using the internal etalon in the laser. This was because the larger hyperfine structure in ${}^7Li^+$ made it difficult to keep $\tau_l < 1$ sec with the narrow laser linewidth. The larger linewidth achieved by using only the birefringent filter in the laser

alleviated this problem but could lead to an error $\leq 2\%$ in $\tau_r(^7\text{Li}^+)$ because of slight wavelength drifts during the data collection. Another possible error related to the laser is the effect of the beam size. Since the spontaneous photons originate from the entire ion cloud but laser-induced photons come only from the region of the laser beam, a difference in the geometrical collection efficiencies could occur. By expanding the laser beam with a telescope, we have put 3% limits on any error arising from this source.

A more serious systematic problem concerns the trap well depth and the electron energy. It was initially observed that well depths $D = 18$ eV with electron energies $E_{elec} < 300$ V generally resulted in smaller values for τ_r than did either well depths $D = 8$ eV or $E_{elec} > 300$ V with $D = 18$ eV. Furthermore, there was little, if any, dependence on E_{elec} for $E_{elec} > 300$ V. We concluded that the stronger rf-fields at $D = 18$ eV were seriously perturbing the trajectories of lower energy electrons, causing trap surfaces and the detectors to charge up slightly during the fill period and leading to systematic errors. With either smaller rf-fields or larger electron energies, the electron trajectories are more nearly straight lines through the trap center, and this problem diminishes. All data included in the final results used $E_{elec} > 300$ V (usually 450 V); the error from this source is judged to be less than 5%.

A final point to consider is the effect of optical pumping of the 2^3S_1 ions. The principle concern is that an alignment of the 2^3S_1 state would result in anisotropic photon emission and cause a systematic error in S_2 . The major parameters affecting optical pumping are the magnetic field and the angle of laser polarization with respect to the field. As is well known¹⁷, the induced dipole created by the laser's electric field is destroyed by a uniform magnetic field when the precession frequency of the dipole exceeds the radiative decay rate (magnetic depolarization). The pertinent condition for magnetic depolarization is

$$\alpha = \frac{\mu_B B}{h\gamma} \gg 1, \quad (14)$$

where B is the field strength, γ is the radiative decay rate, and μ_B is the magnetic moment of the excited state. Our experiment uses an axial magnetic field ≈ 50 gauss to help focus the electron beam. For the case of 2^3P_1 in Li^+ this gives $\alpha \approx 20$, so magnetic depolarization should

be complete. One can further show that, for the case of complete magnetic depolarization, a laser beam polarization at an angle $\theta = \cos^{-1}(1/\sqrt{3}) \approx 55^\circ$ with respect to the magnetic field will produce a uniform distribution of substate populations¹⁷. We have substantiated this by detailed optical pumping calculations as a function of laser wavelength and polarization. Our calculations are in good agreement with observation. A report of these fluorescence studies will be published separately.

By maintaining $B \geq 50$ gauss and $\theta = 55^\circ$ during the collection of all data used for determining τ_r , an isotropic distribution of photons was assured. We have assigned systematic errors of 2% to possibly incomplete magnetic depolarization and 2% to a possible error of a few degrees in θ . Since electron impact excitation could produce some alignment of the initial population of 2^3S_1 ions, leading to an anisotropic M1 decay pattern, some data were taken after an initial brief laser pumping period was used to establish a uniform population of the 2^3S_1 substates. No significant differences were noted between values of τ_r obtained with and without this initial laser pumping.

The results of our data averaging and error analysis are shown in Table 1. An average of the $^6\text{Li}^+$ and $^7\text{Li}^+$ data yields a value of 58.6 sec for the radiative lifetime. The assignment of an appropriate error to this result was done as follows. The errors shown in Table 1 are, with the exception of the 2% statistical error, estimates of unresolved systematic errors. Their effect on the result is always the same, but we cannot correct for them since we do not know the correct sign for each. Our approach is to consider the worst case ; i.e. where all systematic errors affect τ_r in the same way. Thus we add these error estimates and regard the result as a 95% confidence level estimate of the magnitude of unresolved systematic effects. We combine this systematic error in an RMS fashion with the statistical error to achieve our final error estimate. The 12.9 sec error deduced in this manner does not differ significantly from a 2σ error of 11.7 sec found by RMS combination of all the error estimates and the statistical error. The final result is then

$$\tau_r = 58.6 \pm 12.9 \text{ sec.}$$

V. DISCUSSION

Figure 7 shows a comparison of measured and theoretical values of τ_r for Z ranging from 2 to 36. All of the error bars in this figure represent 95% confidence levels in the experimental values. Considering that the lifetimes measured have spanned nearly 14 orders of magnitude, the general agreement of theory and experiment is impressive. Still, it is somewhat disturbing that both $Z = 2$ (He) and $Z = 3$ (Li^+) require 2σ error bars to reach agreement, and both experimental lifetimes are longer than theory predicts. Since the theoretical radiative decay rate scales as Z^{10} , any other process scaling with a lower power of Z could be a contributing factor at low Z while not observed in the higher Z beam-foil experiments. No theoretical hypothesis has been advanced, though, for any mechanism which would inhibit the decay. Obvious competing processes, such as hyperfine-induced decays, could only shorten the lifetime, and they are easily estimated to be several orders of magnitude too small to be of importance. Further work, both experimental and theoretical, would not be without merit as long as the puzzle remains of nonexponential behavior at high Z and possibly longer-than-theoretical lifetimes at low Z .

VI. ACKNOWLEDGEMENT

We wish to express our gratitude to Drs. F. Paresce and S. Bowyer of the University of California Space Sciences Laboratory for the use of their XUV calibration facility.

REFERENCES

^{*}Work supported by the Chemical Sciences Division, Office of Basic Energy Sciences, U. S.

Department of Energy, under contract no. W-7405-Eng-48.

^{**}Present address, Center for Astrophysics, 60 Garden St., Cambridge Mass. 02138.

¹A. H. Gabriel and C. Jordon, *Nature* **221**, 947 (1969).

²G. Briet and E. Teller, *Astrophys. J.* **91**, 215 (1940).

³H. R. Griem, *Astrophys. J.* **156**, L103 (1969).

⁴G. W. F. Drake, *Phys Rev.* **A3**, 908, (1971)

⁵W. R. Johnson and C. Lin, *Phys. Rev.* **A9**, 1486 (1974).

⁶J. R. Woodworth and H. W. Moos, *Phys. Rev.* **A12**, 2455 (1975).

⁷The theory and measurements are summarized by R. Marrus and P. J. Mohr in *Advances in Atomic and Molecular Physics, Volume 14*, ed. by D. R. Bates and B. Bederson (Academic Press, New York 1978).

⁸D. L. Lin and L. Armstrong Jr., *Phys. Rev.* **A16**, 791 (1977).

⁹F. F. Freeman, A. H. Gabriel, B. B. Jones, and C. Jordan, *Phil. Trans. Roy. Soc. Lond.* **A270**, 127 (1971).

¹⁰G. W. F. Drake and A. Dalgarno, *Astrophys. J.* **157**, 459 (1969).

¹¹P. Hvelplund, *J. Phys.* **B 9**, 1555 (1976).

¹²H. G. Dehmelt, *Adv. Atom. Mol. Phys.* **3**, 53 (1967); **5**, 109 (1969).

¹³R. D. Knight, Ph.D. Thesis, University of California, Berkeley (1979) (Lawrence Berkeley Laboratory report LBL-9082).

¹⁴R. D. Knight and M. H. Prior, *J. Appl. Phys.* **50**, 3044 (1979).

¹⁵W. R. Hunter, D. W. Angel, and R. Tousey, *Appl. Optics* **4**, 891 (1965).

¹⁶J. E. Mack, F. Paresce, and S. Bowyer, *Appl. Optics* **15**, 861 (1976).

¹⁷A. Mitchell and M. Zemansky, *Resonance Fluorescence and Excited Atoms* (Cambridge University Press, London, 1934).

Table 1. Summary of measurements and error analysis.

Raw data average X calibration factor (X isotope factor for ${}^6\text{Li}^+$)

${}^6\text{Li}^+$: $\tau_r = 57.4$ sec
 ${}^7\text{Li}^+$: $\tau_r = 59.8$ sec
 Average: $\tau_r = 58.6$ sec

<u>Error Source</u>	<u>Fractional Contribution</u>
Detector calibration	6%
Well depth/electron energy	5%
Background subtraction	2%
Incomplete magnetic depolarization	2%
Laser beam polarization angle	2%
Laser beam size	3%
${}^6\text{Li}^+$: isotope correction ${}^7\text{Li}^+$: laser wavelength drift } }	2%
<hr/>	
Maximum systematic error	22%
Statistical error	2%
<hr/>	

95% confidence error estimate: 22%

Result: $\tau_r = 58.6 \pm 12.9$ sec

FIGURE CAPTIONS

Figure 1. Relevant low lying energy levels of Li^+ . Laser light at 5485\AA excites ions in the 2^3S_1 state to 2^3P_1 from which intercombination radiation at 202\AA is emitted in about 0.1% of the subsequent decays.

Figure 2. Spontaneous M1 and laser induced intercombination E1 decay signals from stored Li^+ ions. The small count rate between 0 and 1 sec is the spontaneous M1 emission; the laser beam is switched into the trap at $T = 1$ sec and the resulting burst of 202\AA E1 photons is a measure of the number of metastable ions present.

Figure 3. Decay of integrated laser induced E1 emission versus the time at which the laser beam is switched into the trap volume.

Figure 4. Total loss rate of 2^3S_1 Li^+ ions versus pressure of CH_4 and H_2 in the trap chamber. The pressure scale is uncalibrated; 100 pressure units is about 1×10^{-9} Torr. The zero pressure intercepts differ because the base pressure in the vacuum chamber was not the same when the two sets of data were collected.

Figure 5. Block diagram of the experiment.

Figure 6. Ion storage loss rate, total metastable loss rate, and metastable radiative decay rate versus pressure of CO. 100 pressure units is about 1×10^{-9} Torr.

Figure 7. Ratio of experimental to theoretical radiative lifetime values for the 2^3S_1 state versus Z . Theoretical values used are from Refs. 4 and 5. The experimental value at $Z = 2$ is from Ref. 6 and those used at $Z = 16$ and higher are summarized in Ref. 7. This work provides the value at $Z = 3$.

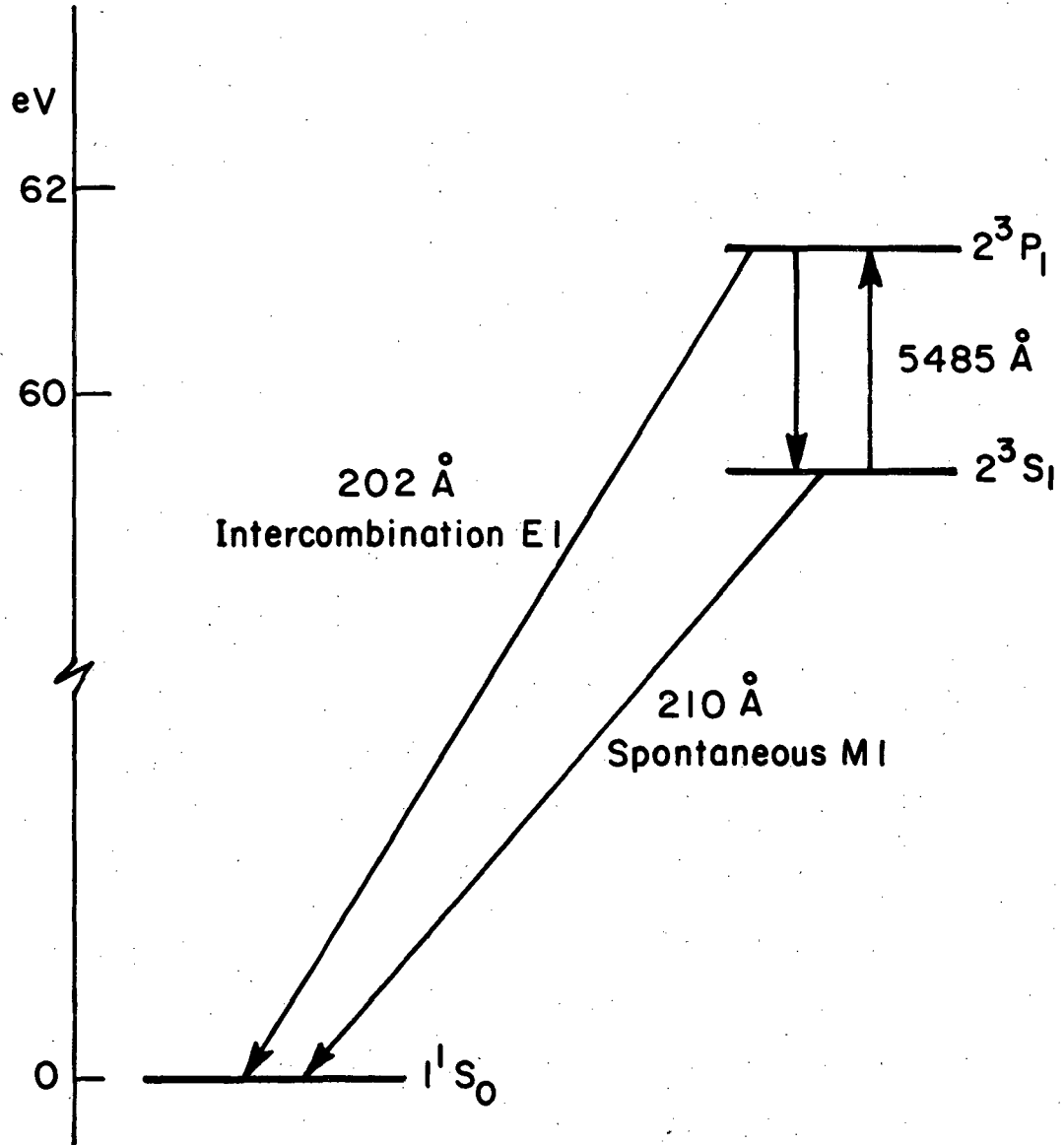

XBL 793-5894

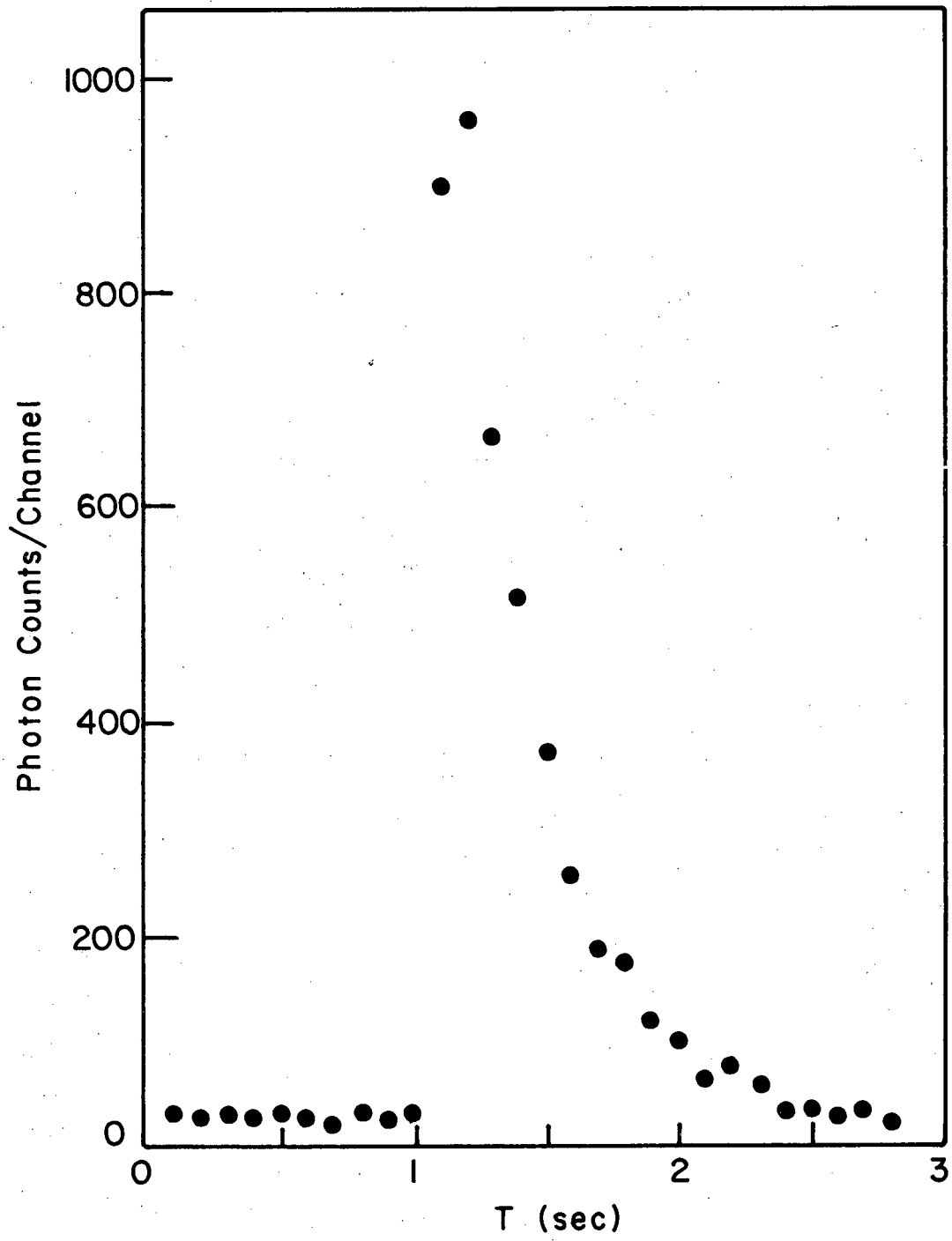

XBL793-5920

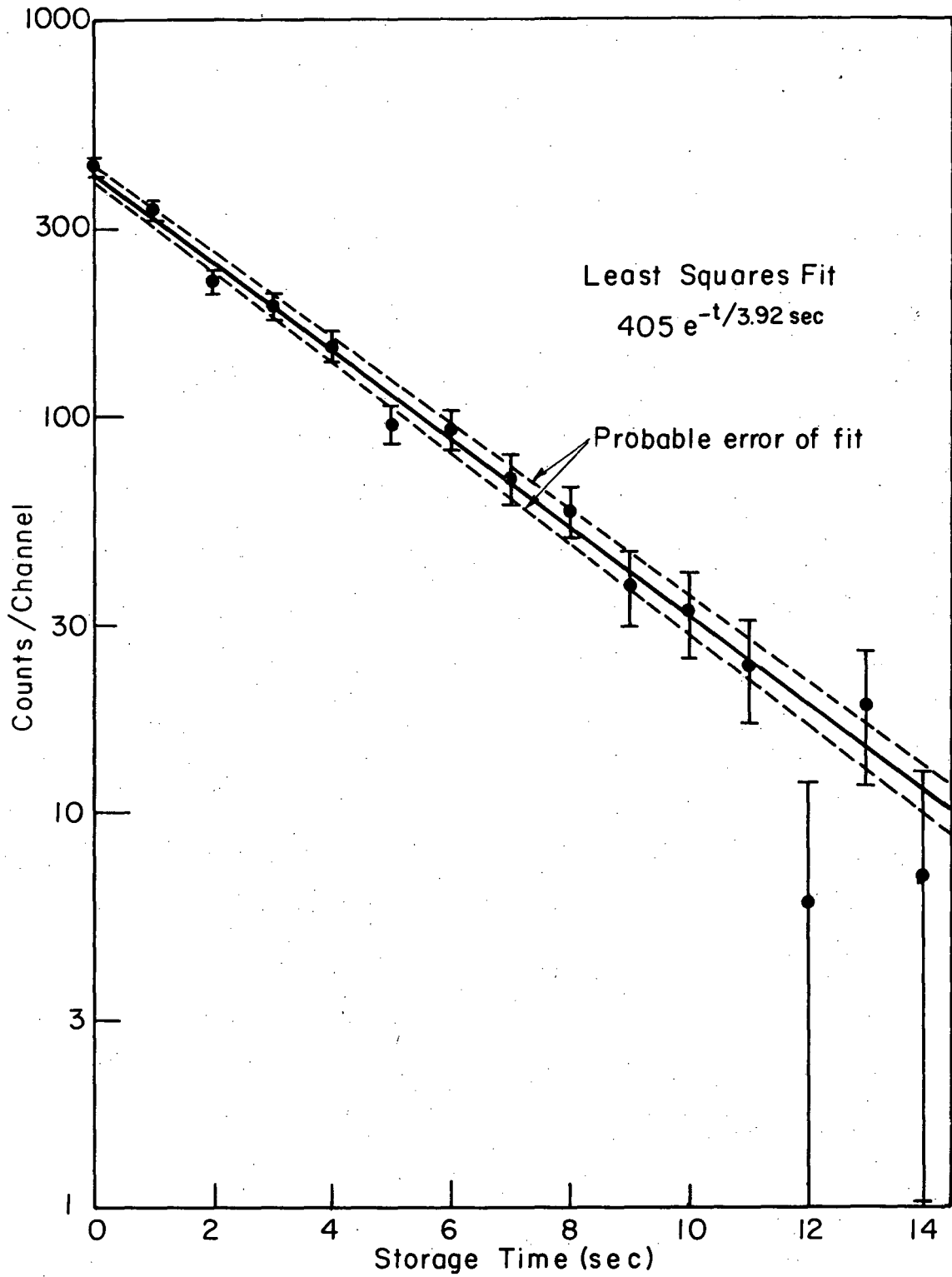

XBL793-5922

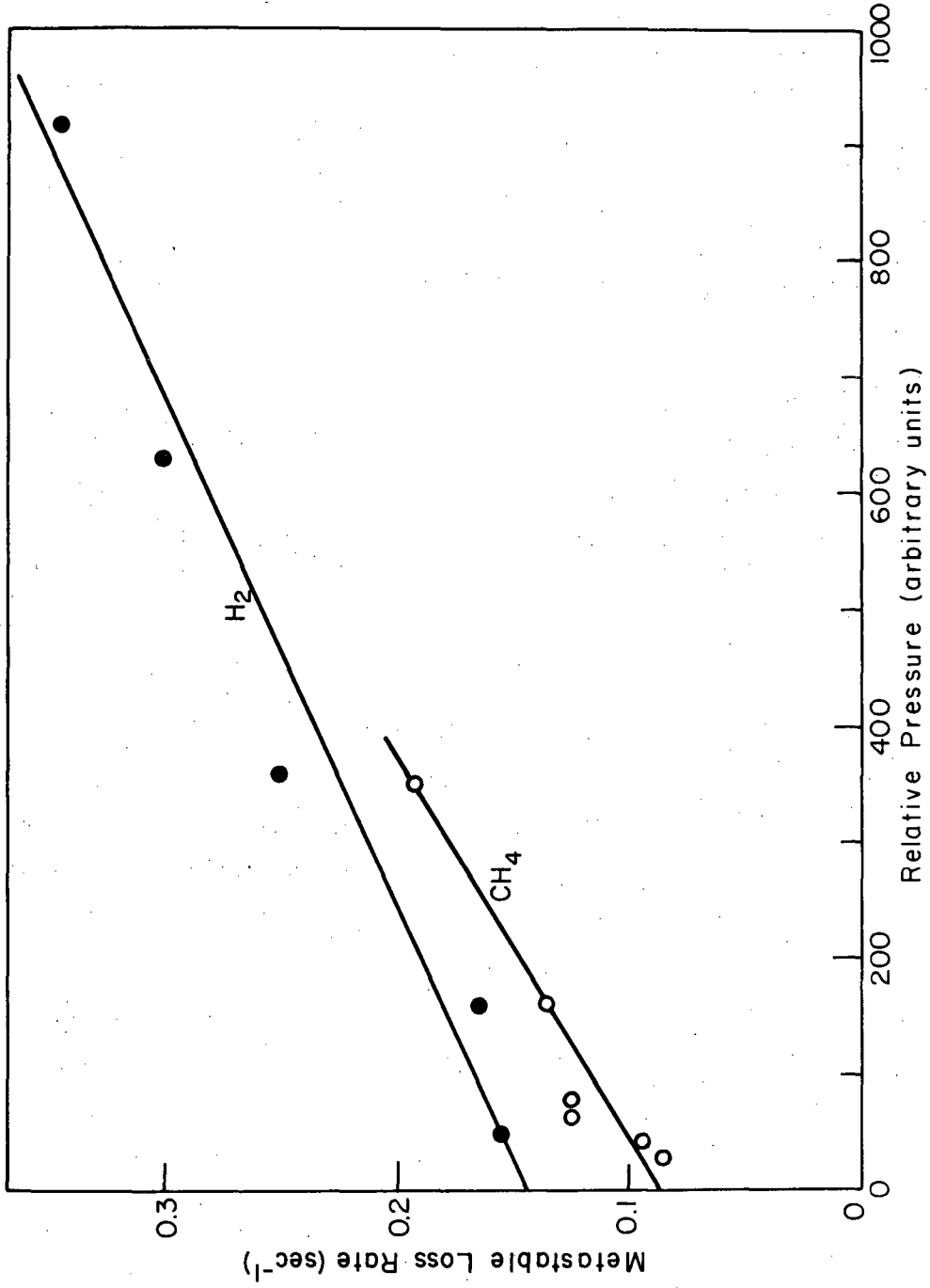

XBL 793-5923

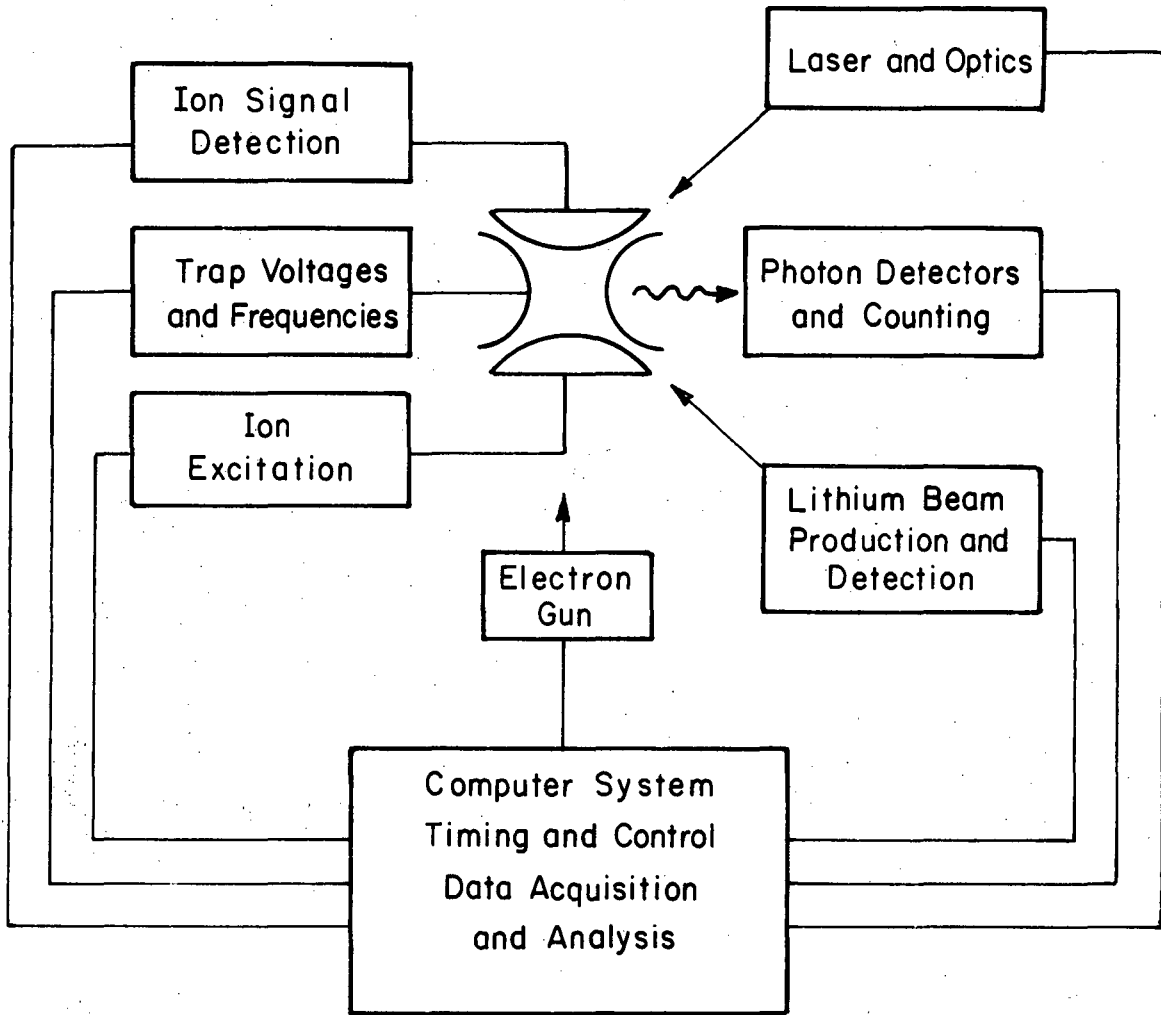

XBL793-5905

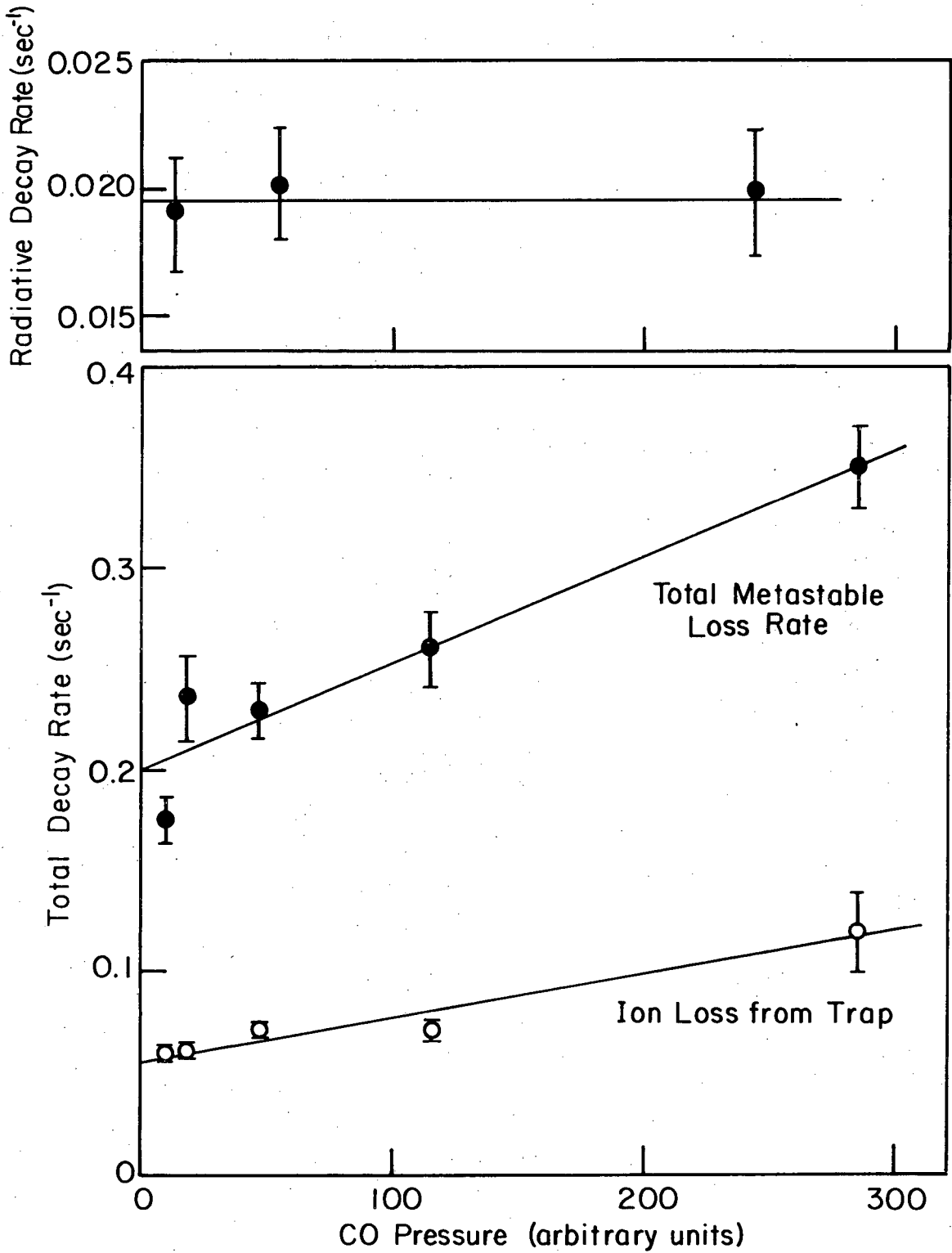

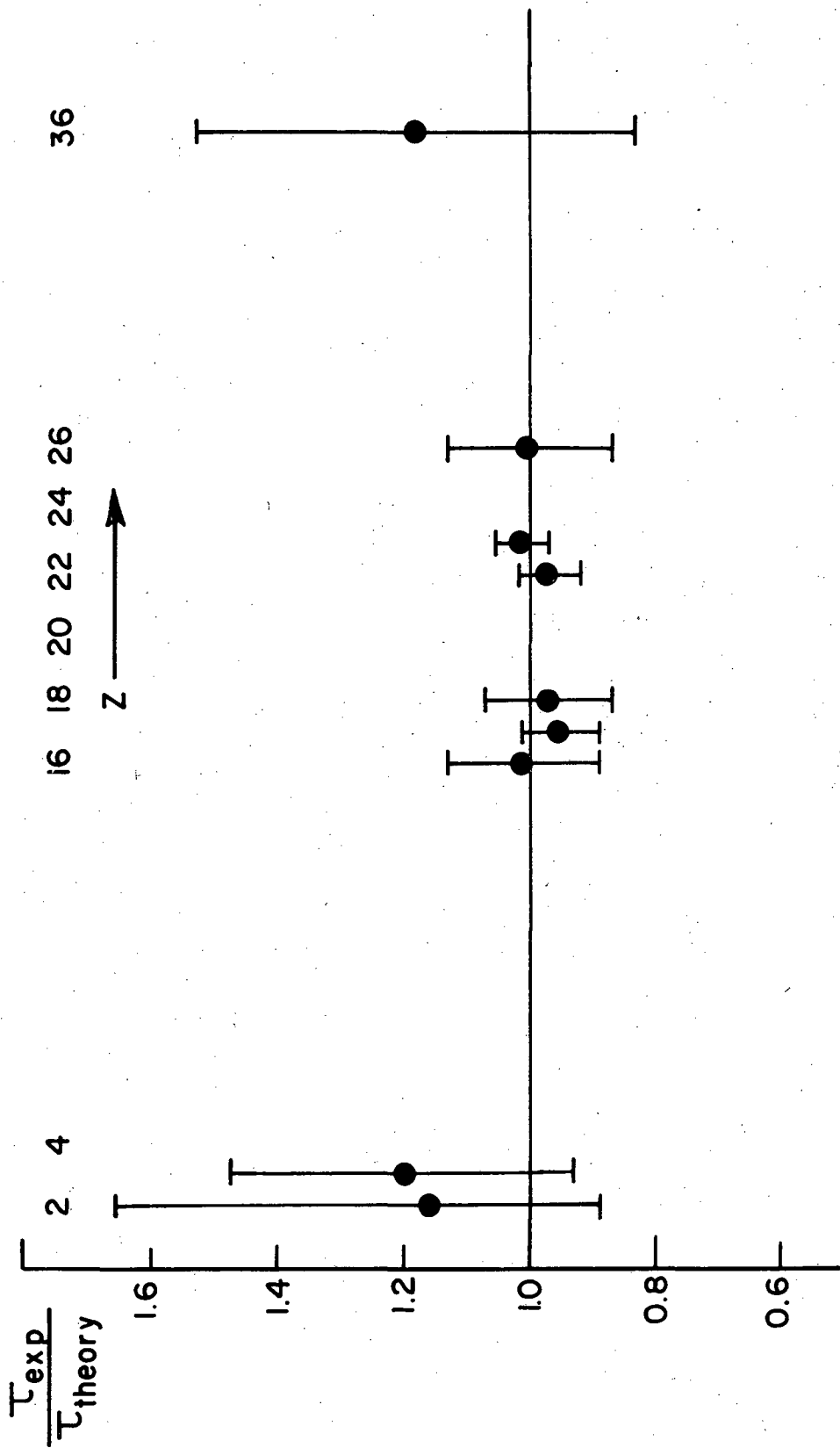

XBL 793-5891

This report was done with support from the Department of Energy. Any conclusions or opinions expressed in this report represent solely those of the author(s) and not necessarily those of The Regents of the University of California, the Lawrence Berkeley Laboratory or the Department of Energy.

Reference to a company or product name does not imply approval or recommendation of the product by the University of California or the U.S. Department of Energy to the exclusion of others that may be suitable.

TECHNICAL INFORMATION DEPARTMENT
LAWRENCE BERKELEY LABORATORY
UNIVERSITY OF CALIFORNIA
BERKELEY, CALIFORNIA 94720