

Lawrence Berkeley National Laboratory

Recent Work

Title

UTILIZATION OF ALGAE FOR WATER PURIFICATION AND PROTEIN PRODUCTION

Permalink

<https://escholarship.org/uc/item/8d1991f2>

Authors

Miller, Steven Frank.
Wilke, Charles R.

Publication Date

1972

e.2

UTILIZATION OF ALGAE FOR WATER
PURIFICATION AND PROTEIN PRODUCTION

Steven Frank Miller* and Charles R. Wilke

January 1972

AEC Contract No. W-7405-eng-48

*Filed as a Ph. D. Thesis

TWO-WEEK LOAN COPY

*This is a Library Circulating Copy
which may be borrowed for two weeks.
For a personal retention copy, call
Tech. Info. Division, Ext. 5545*



48

e.2

DISCLAIMER

This document was prepared as an account of work sponsored by the United States Government. While this document is believed to contain correct information, neither the United States Government nor any agency thereof, nor the Regents of the University of California, nor any of their employees, makes any warranty, express or implied, or assumes any legal responsibility for the accuracy, completeness, or usefulness of any information, apparatus, product, or process disclosed, or represents that its use would not infringe privately owned rights. Reference herein to any specific commercial product, process, or service by its trade name, trademark, manufacturer, or otherwise, does not necessarily constitute or imply its endorsement, recommendation, or favoring by the United States Government or any agency thereof, or the Regents of the University of California. The views and opinions of authors expressed herein do not necessarily state or reflect those of the United States Government or any agency thereof or the Regents of the University of California.

UTILIZATION OF ALGAE FOR WATER PURIFICATION
AND PROTEIN PRODUCTION

<u>Contents</u>	<u>Page</u>
List of Tables.....	v
List of Figures.....	vii
Abstract.....	ix
I. Motivation.....	1
II. Introduction.....	2
III. Water Purification - Concentration Factors.....	4
A. Background for the Water Purification Problem.....	4
B. Outline of the Experimental Approach.....	6
C. Experiment 1 - Kinetics.....	6
D. Experiment 2 - Mechanism.....	8
E. Experiment 3 - Absorption Capacity and Selectivity.....	14
F. Experiment 4 - Data Test.....	23
IV. Water Purification - Economic Evaluation.....	30
A. Introduction.....	30
B. Description of the Oak Ridge Ion Exchange Scavenger Precipitation Process.....	30
C. Description of the Algal Clean-up Process.....	34
D. Cost Analysis of the Algal Clean-up Process.....	38
E. Results and Conclusions.....	40
V. Phototactic Separation.....	43
A. Introduction.....	43
B. Background.....	44
C. Exploratory Investigations and Development of Equipment.....	45

D. Experiments with the Inclined Wall Phototactic Separator.....	49
E. Scale-up of a Phototactic Separator.....	55
F. Keeping Pandorina Dominant in a Pond.....	57
VI. Algae as a Protein Source.....	59
A. The Direction.....	59
B. Comments on Pandorina morum Borey used in Analysis.....	60
C. Discussion of Results of Amino Acid Analysis.....	62
D. Discussion of Results.....	62
VII. Summary of Conclusions.....	64
Acknowledgments.....	66
Appendix A. Support Equipment and Standard Procedures.....	67
Appendix B. Computer Program for Experiment 4.....	81
Appendix C. Computer Program for Cost Analysis.....	86
Appendix D. Amino Acid Analysis Procedure.....	99
References.....	100

LIST OF TABLES

	<u>Page</u>
Table 1. Single Ion Uptake Experiments.....	17
Table 2. Mixed Ion Uptake Experiments.....	18
Table 3. Ion Concentration In Equilibrium Solutions.....	26
Table 4. Estimated Cost of the Oak Ridge Process.....	33
Table 5. Comparison of Estimated Costs of the Sr Removal Processes....	41
Table 6. Results of Phototactic Runs 2 & 3.....	56
Table 7. Amino Acid Analysis of Pandorina morum.....	62
Table 8. Dry Weight via 90° Drying Oven.....	78
Table 9. Methods of Sample Digestion.....	80

LIST OF FIGURES

	<u>Page</u>
Fig. 1 Mg ⁺⁺ Uptake by Pandorina.....	12
Fig. 2 Ca ⁺⁺ Uptake by Pandorina.....	13
Fig. 3 Cation Uptake Data for Young Algae.....	19
Fig. 4 Mg ⁺⁺ Uptake.....	20
Fig. 5 Sr ⁺⁺ Uptake.....	21
Fig. 6 Ca ⁺⁺ Uptake.....	22
Fig. 7 Data Test - Flow Sheet.....	25
Fig. 8 Comparison of Computer Predictions and Experimental Results..	27
Fig. 9 Comparison of Computer Predictions and Experimental Results..	28
Fig. 10 The Oak Ridge "Ion Exchange Scavenger Precipitation Process":.....	31
Fig. 11 Two Algal Clean-up Process Variations.....	35
Fig. 12 Flow Diagram of 4 Contacting Stages.....	37
Fig. 13 The Horizontal Channel Phototactic Separator.....	46
Fig. 14 The Inclined Wall Phototactic Separator.....	48
Fig. 15 Phototactic Separation Run 1.....	51
Fig. 16 Phototactic Separation Run 2 - Light On.....	52
Fig. 17 Phototactic Separation Run 3 - Light Off.....	53
Fig. 18 Block Diagram of Computer Do Loops.....	89

UTILIZATION OF ALGAE FOR WATER PURIFICATION
AND PROTEIN PRODUCTION

Steven Frank Miller and Charles R. Wilke

Lawrence Berkeley Laboratory
University of California
Berkeley, California

December 1971

ABSTRACT

This thesis contains a broad ecological sketch as well as specific design information for solving problems of water purification and food production. A plant is designed utilizing algae as living ion exchange beads for removal of Sr from low level radioactive waste streams. Preference of Sr over Ca by *Pandorina morum* Borey is found to be 1.2 to 1 with a higher than expected value of 1.4 milliequivalents of cation exchange sites available per gram dry weight of algae. Plant economics based on utilization of conventional separators are found to be unpromising.

A "Phototactic" separation device is designed and data presented for this novel means of harvesting algae at a possible reduced cost. Cheap algal harvesting also has implications for algal agriculture. *Pandorina* was analyzed for protein content and found promising. Methods of *Pandorina* culture are discussed briefly.

A novel laboratory algal growth reactor with an externally falling cooling film is also presented.

I. MOTIVATION

Man is the Lord's shepherd for the Biosphere. The day has passed when he was the simple child of the garden of Eden, a garden rich beyond his capacity to alter and destroy. Today he must accept responsibility for maintaining ecological balance, for seeing that the garden maintains its beauty and diversity, or forever resign his species to live and die in the rubble of his own greed. It is through the shepherd's communal consciousness that the corrections for the future course of nature must arise. This theses records a crude outline, one of the many possible paths open to our future choosing.

Man's problems in the biosphere are multifold. Many of these problems such as food supply, CO₂ recycle, sewage disposal, maintenance of streams, recovery of radioactive and trace elements from the waters, could all be potentially solved by a large and well planned agriculture based on algae. (Provided, of course, a stable human population size were achieved and efforts were made to reduce both pollution and ostentatious waste of resources.) The efforts required to carry out this extensive endeavor are enormous but necessary if men are to live in harmony with the biological universe.

II. INTRODUCTION

Pandorina morum Borey is a sixteen celled green algae in the same family as *Chlamydomonas*. During part of its life cycle it is a rapid swimmer (1-2 cm/min). We did not find any data in the literature on either the food value or the cation absorption or cation exchange characteristics of these organisms. After some preliminary examination of other green algae, including *Chlorella*, *Chlamydomonas*, *Volvox*, and *Euglena*, we chose *Pandorina* as the organism for our investigation.

The chapters of this thesis are arranged as follows: Chapters III and IV concern the utilization of algae as living ion exchange beads to absorb radioactive cations such as Sr from the low level waste streams of nuclear reactors. Chapter III presents experiments and results establishing the ion exchange characteristics of *Pandorina*. Chapter IV presents an economic analysis of some possible plant designs for the removal of Sr from the low level radioactive waste streams. The economic analysis is based on data obtained in Chapter III.

Methods of concentrating dilute solutions of algae have prove to be expensive. The results of Chapter IV are quite dependent on the handling costs of algae. Therefore, cheap means of handling algae are worth investigating. Chapter V presents a novel means of algal harvesting which we call Phototactic Separation where *Pandorina* swim toward a light source and are collected. This may be a cheaper means of handling algae than the usual alternative of centrifugation.

The high cost of harvesting is also an obstacle to the utilization of algae as a food source. Therefore having a novel and perhaps cheaper means of handling and harvesting *Pandorina*, we became interested in the

protein value of this organism. Chapter VI presents the results of amino acid analysis of Pandorina. Chapter VII contains a summary of results and conclusions.

Descriptions of equipment, standard procedures, and computer programs are presented in the Appendices.

III. WATER PURIFICATION - CONCENTRATION FACTORS

A. Background for the Water Purification Problem

Radioecologists and investigators in related fields have known that microorganisms tend to concentrate inorganic cations to levels far above their immediate environment. The concentration of radioactive species such as Sr^{90} that results from algal pick up of strontium has been considered a potential hazard to the food chain which leads from algae to fish and then, in turn, to man.

Many observations have been made of "concentration factors" for various cations of radiochemical interest.¹ These observations all seem to have been made from a "Health Chemistry" point of view, (i.e., of the potential hazard to the environment). The results were usually qualitative, the studies being carried out in very complex systems corresponding to typical conditions in natural streams. However, attempts at obtaining quantitative information were made by Austin, Toumeinin, and others, with varying degrees of success. We found no data specifically for *Pandorina morum* Borey.

In regard to the mechanism of ion uptake, according to Jennings² algae absorb metal ions on their surface, in their cytoplasm, and in their vacuoles. Surface absorption (or adsorption) appears to be relatively fast and reversible and is probably the only uptake which will affect an industrial scale process. Knight³ reports that the surface of green algae provide approximately 56 milliequivalents of sites for cation absorption per 100 grams dry weight of algae. This figure indicates a total absorption capacity of .05 grams Sr/gram dry weight algae or 0.022 grams Ca/gram dry weight algae. Knight correlates the number of sites with the uronic acid

content of the cell walls of a variety of different organisms in addition to green algae. However, green algae themselves do not contain uronic acids and must have some other molecule or molecules functioning as absorption sites.

Austin⁴ attempted to obtain an equation for Ca-Mg-Sr absorption by *Chlorella pyrenoidosa*. He grew the organisms in a continuous culture varying the Ca-Mg-Sr composition of the media from experiment to experiment. Varying the media composition unfortunately also varied the final bio-mass and the history of the algae produced in each run. In particular, low Mg concentrations led to cultures which were too dilute to be usable because Mg is required as a nutrient by the organism. Therefore, the range of conditions investigated were restricted. Another difficulty in utilizing Austin's results is that it is impossible to differentiate between absorption due to those processes which are both fast and reversible and those which are either slow or irreversible. Finally, Austin's data showed several internal inconsistencies.

Austin found that *Chlorella* preferred to absorb Ca ions relative to Sr ions by a factor of 1.35 to 1 on a mole basis. Tuominen⁵ found the opposite true for *Cladonia alpestris* (Sr preferred to Ca by a factor of 1.5 to 1). Helfferich⁶ (pg. 168-) indicates that apart from specific exceptions, the usual selectivity sequence for most cation ion exchange beads is as follows: $Ba^{++} > Sr^{++} > Ca^{++} > Cu^{++} > Ag^+ > Cs^+ > K^+ > Na^+ > Li^+$. Note that the divalent ions above are uniformly selected over the monovalent ones.

Since the profitability and design of our process for removal of Sr from low level radioactivity waste water streams was directly dependent on the total number of cation exchange sites and the selectivity of the sites for Sr relative to other competing cations, we decided to carry

out our own investigation to obtain the necessary design data.

B. Outline of the Experimental Approach

In Chapter III we present the experiments performed to obtain information about the ion exchange characteristics of Pandorina. This information is necessary for the process design presented in Chapter IV. The experimental work in this section is broken down into four experimental subsections in the following way:

1. Experiment 1 - Kinetics. In the first experiment we examine the question, "must the kinetics of the cation uptake be considered in the design of our process?" Or, in other words "is the kinetics fast enough to be ignored?"

2. Experiment 2 - Mechanism. In this sub-section we evaluate the question, "are we dealing with ion exchange?" Or, phrased differently, "is the absorption dependent on the total concentration of the ions in the external solution?"

3. Experiment 3 - Absorption Capacity and Selectivity. In experiment 3 we consider the following questions: "What is the selectivity coefficient describing the preference of sites for absorbing Sr ions relative to Ca and Mg ions?" "What is the effect of pH?"

4. Experiment 4 - Data Test. In Experiment 4 we test: "Can the data obtained in experiments 1, 2, and 3 successfully predict the outcome of a staged experiment?"

C. Experiment 1 - Kinetics

1. Purpose

The purpose of this experiment is to establish whether or not we must consider the kinetics of cation uptake by the algae when we carry out

our plant design. If kinetics are "slow" they will be important. If, however, the cation uptake is almost "instantaneous" (i.e., quick relative to the period of time that the algae are held in each stage) the kinetics need not be considered.

2. Equipment

This experiment required: Pandorina, 12 ml centrifuge tubes, and an Atomic Absorption Spectrophotometer (A. A.)

3. Procedure

- a) Algae for all four experiments were grown as described in Appendix I. Upon harvesting, the Pandorina were equilibrated with a large volume of a solution containing 5 ppm Ca^{++} and 5 ppm Mg^{++} for 12 hours.* Then the Pandorina were concentrated to 0.04 packed cell volume and 10 ml aliquots were transferred to two 12 ml pyrex centrifuge tubes.
- b) The tubes were centrifuged and the supernatant decanted. The residue was diluted to 10 ml with a solution containing 0.0 ppm Ca^{++} and 10.0 ppm Mg^{++} . The residue was resuspended and agitated vigorously for 2 minutes. The tubes were then quickly centrifuged and 1 ml of the supernatant fluid removed for atomic absorption analysis.
- c) The algae were immediately resuspended in the remaining nine ml of liquid, agitated vigorously for 4 minutes, recentrifuged, and again 1 ml of each tube was sampled for atomic absorption analysis.
- d) The algae were again immediately resuspended in the remaining 8 ml of liquid, agitated for an 8 minute period, recentrifuged, and

* Anions of all salt solutions in this thesis may be assumed to be Cl^- unless otherwise stated.

another 1 ml of supernatant removed from each tube for analysis.

e) Finally, the algae were resuspended in the remaining 7 ml, agitated for 16 more minutes, recentrifuged, and the supernatant resampled.

4. Results

The samples of supernatant were analysed for Ca^{++} and Mg^{++} content via the Atomic Absorption Spectrophotometer (described in Appendix I). The supernatant concentration sampled after the first two minute agitation period was 6.86 ppm Ca^{++} and 2.35 ppm Mg^{++} in one tube and 6.72 ppm Ca^{++} and 2.47 ppm Mg in the other tube. The atomic absorption analysis results for the samples taken after each of the additional 4, 8, and 16 minute periods showed no additional change in the Ca^{++} or Mg^{++} concentration of the supernatant. It was therefore concluded that the absorption process took less than two minutes.

5. Conclusion

Since the absorption process took less than two minutes, we consider the process to be relatively fast. It would not be difficult to arrange for two minutes of holding time between each stage of our process and between each stage of the experiments which follow.

D. Experiment 2 - Mechanism

1. Purpose

The purpose of this experiment is to determine a useful model for the mechanism of the cation uptake by the algae. Such a model is necessary for the design and interpretation of the experiments which follow in this chapter and for the plant design presented in Experiment 4. We examine two possible models in Experiment 2:

a) In physical absorption models, the quantity of cations absorbed

is determined by the concentration of the external solution. With the model a salt may be more or less absorbed or eluviated depending on how its concentration in the bulk solution varies.

b) For ion exchange models, the existing sites for cations are almost always occupied.

Experiment 2 has two parts. In part 2a algae were loaded with Ca^{++} and Mg^{++} cations and then suspended in distilled water to test whether cations were eluviated. If this were a case of physical absorption, we would have expected a measurable amount of material to leave the algae and enter the bulk solution. If, however, this were a case of ion exchange, cations would stay with the sites on the algae and not be eluviated by the distilled water.

In part 2b we examine the exchange of Mg^{++} for Ca^{++} and then Ca^{++} for Mg^{++} . Here we intend to demonstrate a quantitative exchange of one cation for another.

2. Equipment

This experiment required: Pandorina, 12 ml test tubes, 90°C drying oven, and an Atomic Absorption Spectrophotometer (A. A.).

3. General Procedure

Pandorina used in Experiment 2 were grown in a flat reactor (see Appendix A; also see Appendix A, section 1d for a description of our novel falling film cooled flat growth tank).

The experiment was carried out in "stages". All stages were performed in duplicate in 12 ml pyrex centrifuge tubes. A stage consisted of the following steps:

a) The starting product was an algal residue remaining in a

pyrex centrifuge tube as a result of a previous centrifugation and decantation of supernatant liquid. (Algae entering the first stage were separated directly from their growth media. In all other stages, the algae were the resultant product of the previous stage.)

- b) The residue packed cell volume (pcv) was noted.
- c) A fresh solution with which the algae were to be contacted was then added to the tube until the total volume of liquid plus algae was 10 ml.
- d) The tube was covered with parafilm, the residue resuspended, and then agitated vigorously for two minutes.
- e) The tube was centrifuged.
- f) The supernatant was decanted and set aside for A. A. analysis of its Mg^{++} and Ca^{++} content.
- g) The residue was then ready to enter the next stage.

4. Procedure 2a

Experiment 2a had two parts. In the first part, the solution used to contact the samples in the first three stages contained 10 ppm Ca. The contacting solution for the fourth and fifth stages was distilled water. In part two, a similar experiment was run with a second pair of samples. This time the contacting solution for the first three stages was 0.0 ppm Mg^{++} and 10 ppm Ca^{++} . The fourth and fifth stages were again contacted with distilled water.

5. Results of Experiment 2a

A. A. Analysis of the supernatant fluid resulting from contacting the algae with distilled water showed a conspicuous lack of Ca^{++} and Mg^{++} ions.

6. Procedure 2b

A pair of Pandorina samples were contacted in 7 consecutive stages with a solution containing 0.0 ppm Mg^{++} and 10 ppm Ca^{++} . The same samples were then contacted in 7 more stages with a solution containing 10 ppm Mg^{++} and 0.0 ppm Ca^{++} . Finally the samples were contacted with one more stage containing 0.0 ppm Mg^{++} and 10 ppm Ca^{++} .

7. Results of 2b

The Ca^{++} and Mg^{++} ion uptake by the algae as deduced from the A. A. analysis of the solutions in equilibrium with the algae are presented in Figs. 1 and 2. We note that after the first 7 stages when other ions such as K^+ originally present in the growth media are completely eluviated from the algae, that the μ moles /gram dry weight algae of Mg^{++} desorbed exactly equals the μ moles /gram dry weight algae of Ca^{++} absorbed. This suggests a 1 for 1 exchange. Furthermore, extrapolation of the absorption curves to two plateaus of saturation indicate the total number of millimoles of absorption sites/gram dry weight of algae is on the order of 1.0 or 1.2, a range confirmed by later experiments.

pH determinations were made on the contents of the first and the final stages. The pH of the Pandorina solution initially was 6.78 and after 15 stages was 6.72, indicating virtually no pH change.

8. Conclusions

We concluded from Experiment 2 that we are not dealing with mere absorption of a salt, but rather with an exchange process that requires anions in solution in order to release cations from the algae.

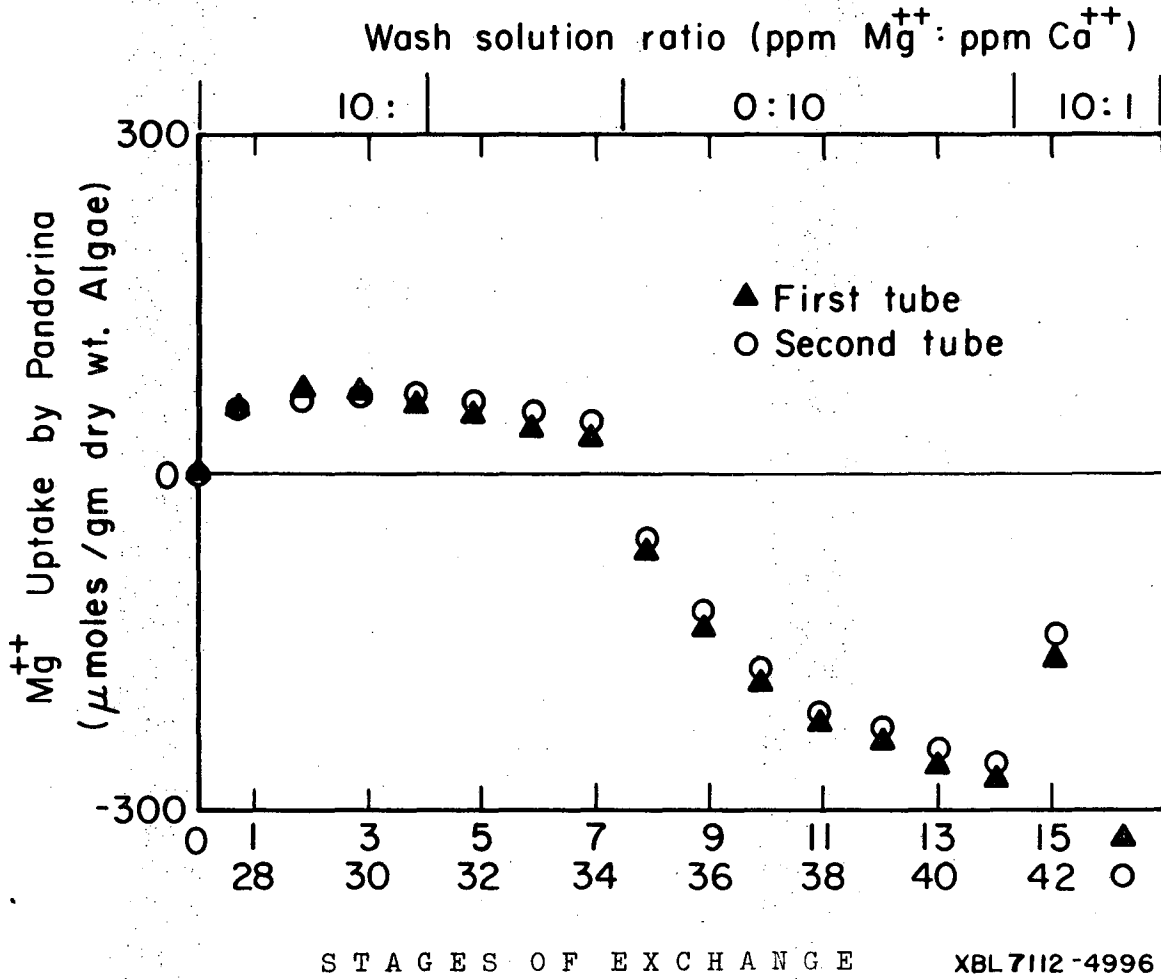
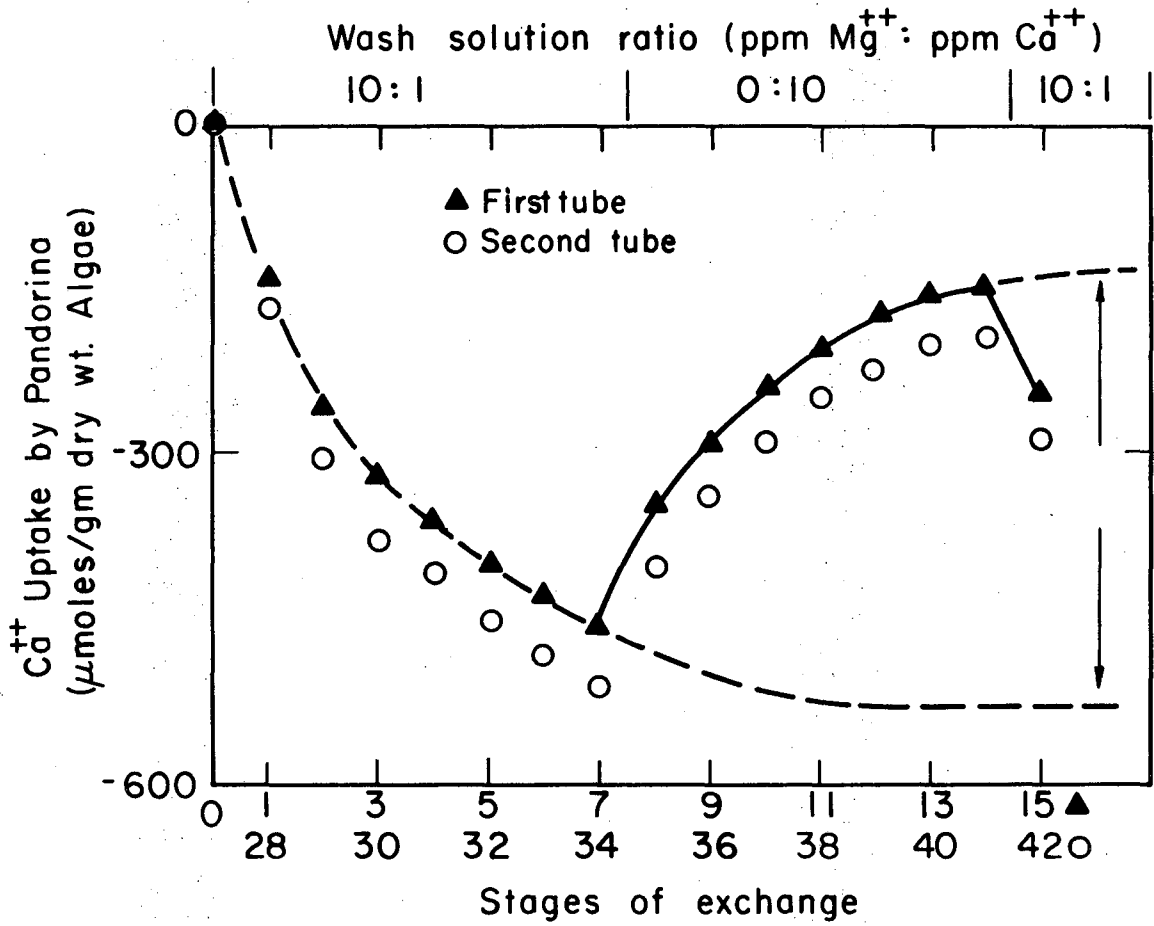

Fig. 1. Mg^{++} uptake by Pandorina in two duplicate tubes is plotted as a function of stages of exchange.



XBL7112-4995

Fig. 2. Ca⁺⁺ uptake by Pandorina in two duplicate tubes as a function of stages of exchange.

E. Experiment 3 - Absorption Capacity and Selectivity

1. Purpose

In order to proceed with the plant design in Chapter IV we need to know the stoichiometry of the absorption process. In Experiment 3 we determine the total number of cation exchange sites and the selectivity coefficients describing the preference of these sites for absorbing Sr ions relative to Ca and Mg ions. We also investigate the effect of pH on absorption of Sr, Ca and Mg cations.

2. Equipment

This experiment required: Pandorina, 40 ml Nalgene centrifuge tubes, a Metler balance, a Vortex mixer, Centrifuge, porcelain crucibles and ashing equipment, Atomic Absorption Analyzer, and salt solutions. The salt solutions used in this experiment contained a total of 0.1 M cation. The list of these solutions includes: 0.1 M solutions of CaCl_2 , MgCl_2 , and SrCl_2 as well as various combinations of these three salts.

3. Procedure

Experiment 3 was made up of 6 sets of experiments. Each set began with the preparation of a series of Mg^{++} "saturated" algal samples which provided uniform starting material. Each sample was then contacted by a salt solution in a series of stages, and then ashed and analyzed on the A. A. (For ashing and A. A. analysis procedures see Appendix A).

Below is a sample of the procedure which was followed in all 6 sets of experiments.

a) Preparation of samples

1000 - 3000 ml of Pandorina were removed from a tubular growth reactor and concentrated by centrifugation. The supernatant fluid was dis-

carded. The algae was resuspended in a similar volume of 0.5 M MgCl_2 solution. This washing procedure was repeated until we had washed with three 200 ml 0.5 M MgCl_2 washes followed by four 200 ml distilled water washes. The MgCl_2 washes were to cover all available absorption sites with Mg ions. The distilled water washes were to remove all traces of salt from the interstices. We had now prepared a standard Mg^{++} saturated algae to use as our starting material.

b) Contacting by a salt solution

A set of experiments consisted of a series of tubes containing standard algal samples. Each tube was assigned to be contacted with a specific salt solution in successive stages as follows:

- to the standardized Mg^{++} saturated residue in a 40 ml Nalgene tube was added 30 ml of the 0.1 M salt solution assigned to it. (Ca^{++} , Mg^{++} , Sr^{++} , or a mixture of these ions).
 - the residue was suspended and agitated for 2 minutes with a Vortex mixer and then centrifuged. The supernatant was discarded and the residue entered the next stage and again contacted with a fresh 30 ml sample of the same 0.1 M salt solution.
- After the agitation step of the third and the eighth stages, pH readings were taken. After the tenth stage, the algal residue was transferred to a porcelain crucible for dry weight determination, ashing and A. A. analysis of its Ca^{++} , Mg^{++} , and Sr^{++} content.

4. Discussion of Results

The results of Experiment 3 are plotted in Figs. 3 to 6 and in Tables 1 and 2. The results of single cation eluviation studies indicate the

following tendencies:

a) For a given cation and the same pH solution, younger cultures (i.e., more actively growing, less dense) have a slightly larger number of sites/gram dry weight algae than older, less vigorous cultures. Note in Figs. 3 to 6 that the algal cultures are characterized with respect to culture age as follows: a_1 , and a_1' , are the youngest cultures, a_2 , a_3 , a_4 , a_5 represent cultures in order of increasing age.

b) For a given young culture, the total absorption capacity for a particular cation increases between pH 4.0 and pH 5.5 and appears constant for pH's outside this range. Furthermore, at any given pH within the range of pH's where total absorption capacity is increasing the organisms tend to absorb Sr^{++} more than Ca^{++} , and Ca^{++} more than Mg^{++} . This trend of preferences for $Sr^{++} > Ca^{++} > Mg^{++}$ is similar to the trend indicated by the selectivity coefficient experiments reported below (see Table 2 and Eq. 1). These results indicate that some sites are stronger acids than others and that there are at least two kinds of sites.

c) The total capacity for cation absorption (T) appears to be about 1.4 milliequivalents of sites/gram dry weight algae at pH 5.5 and about 0.75 milliequivalents of sites at pH 4.0. Capacity for cation absorption (T) appears to be about 1.4 milliequivalents of sites per gram dry weight algae at pH 5.5, and about 0.7 milliequivalents at pH 4.0.

d) Determination of selectivity coefficients

The results of the mixed-cation contacting experiments and their

LIST OF TABLES

	<u>Page</u>
Table 1. Single Ion Uptake Experiments.....	17
Table 2. Mixed Ion Uptake Experiments.....	18
Table 3. Ion Concentration In Equilibrium Solutions.....	26
Table 4. Estimated Cost of the Oak Ridge Process.....	33
Table 5. Comparison of Estimated Costs of the Sr Removal Processes....	41
Table 6. Results of Phototactic Runs 2 & 3.....	56
Table 7. Amino Acid Analysis of Pandorina morum.....	62
Table 8. Dry Weight via 90° Drying Oven.....	78
Table 9. Methods of Sample Digestion.....	80

EXPERIMENT 3

TABLE 1. Single Ion Uptake Experiments

Run #	Mg*	pH	Age	Run #	Sr*	pH	Age	Run #	Ca*	pH	Age
1-2	707		a ₁	6-8	542	4.41	a ₁	6-1	650	5.57	a ₁
6-16	685	5.64	a ₁	6-9	491	4.41	a ₁	6-2	685	5.57	a ₁
6-17	590	5.64	a ₁	6-10	705	6.64	a ₁	6-3	504	4.87	a ₁
6-18	390	4.01	a ₁	6-11	700	6.64	a ₁	6-4	500	4.87	a ₁
6-19	400	4.01	a ₁	6-22	740	5.60	a ₁	6-26	675	6.50	a ₁
6-20	345	2.07	a ₁	6-29	720	5.60	a ₁	6-27	630	6.50	a ₁
6-21	375	2.07	a ₁	6-31	705	5.60	a ₁	2-31	520	5.55	a ₂
6-22	745	6.54	a ₁	6-32	665	5.60	a ₁	1-1	608	-	a ₁
6-23	620	6.54	a ₁	3-1	498	5.58	a ₃				
2-34	672	5.95	a ₂	3-2	468	5.58	a ₃				
3-4	490	5.62	a ₃	414	364	2.81	a ₄				
4-13	520	5.61	a ₄	5-21	463	5.69	a ₅				
4-15	309	2.81	a ₄	2-32	557	5.80	a ₂				
5-5	503	5.74	a ₅	2-35	473	2.83	a ₂				
				1-3	700	-	a ₁				

* μ moles of ion/gram dry weight of algae.

EXPERIMENT 3

TABLE 2. Mixed Ion Uptake Experiments

Run #	Composition			Uptake (mole/gm dry wt algae)			Selectivity Coefficient			Total Uptake	pH
	Sr	Ca	Mg	Sr	Ca	Mg	$\frac{Ca}{K}$ \frac{Mg}	$\frac{Sr}{K}$ \frac{Mg}	$\frac{Sr}{K}$ \frac{Ca}		
3-5	1/3:	1/3:	1/3	188	178	92	1.93	2.02	1.06	458	5.49
2-10	1/3:	1/3:	1/3	214	214	130	1.55	1.55	1.00	558	5.63
2-11	1/3:	1/3:	1/3	211	171	104	1.65	2.03	1.24	486	2.83
3-6	1/2:	1/2:	0	236	188				1.24	424	5.48
3-7	1/2:	0:	1/2	327		145		2.25		472	5.58
3-8	0:	1/2:	1/2		267	146	1.83			413	5.29
4-16	1/2:	1/2:	0	211	180				1.18	391	5.32
4-17	1/2:	0:	1/2	308		164		2.13		476	5.49
4-18	0:	1/2:	1/2		242	180	1.75			422	5.27
5-23	2/3:	1/3:	0	313	140				1.19	453	5.55
5-24*	1/3:	2/3:	0	23	41				1.12	-	5.36
5-25	0:	1/3:	2/3		116	180	1.29			296	5.28
5-26	0:	2/3:	1/3		188	72	1.31			260	5.26
5-27	1/3:	0:	2/3	200		200		2.00		400	5.55
5-28	2/3:	0:	1/3	355		76		2.34		431	5.70

* Unknown fraction of material lost during ashing. Ratio of ions should still be valid.

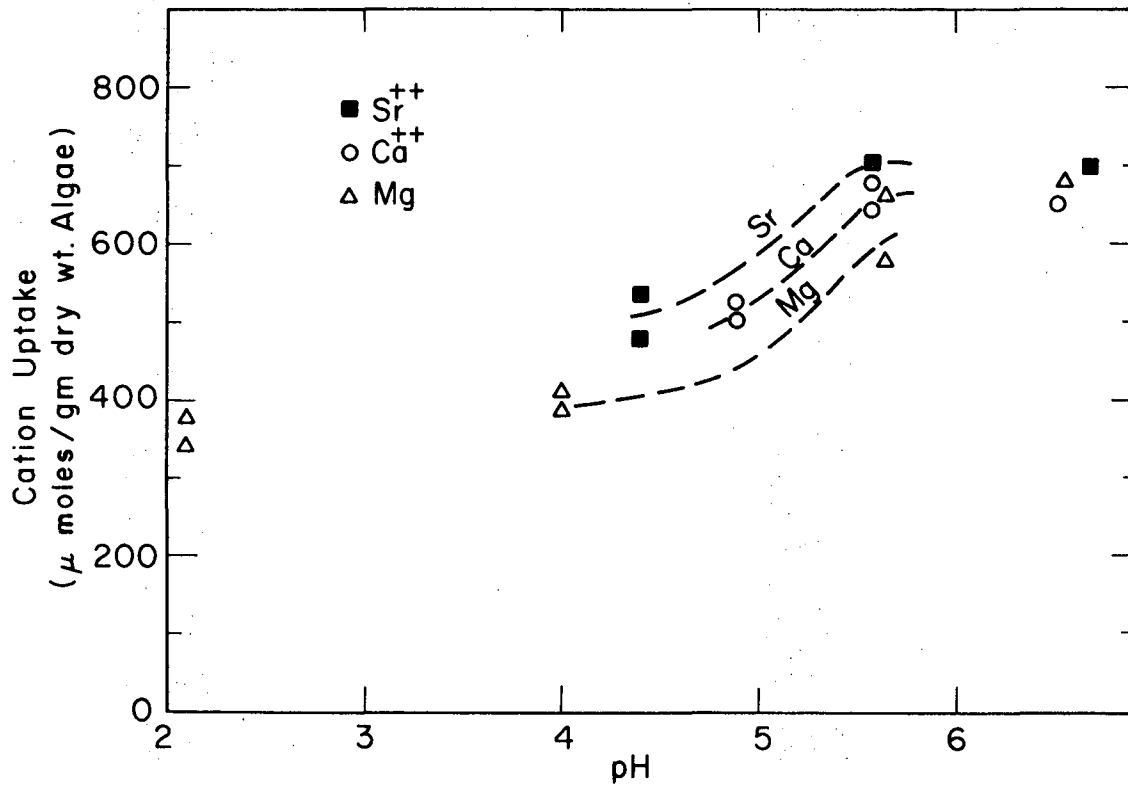

XBL 7112 - 4992

Fig. 3. Cation uptake data for young algae. Data corresponds to the a_1' values listed in table 1.

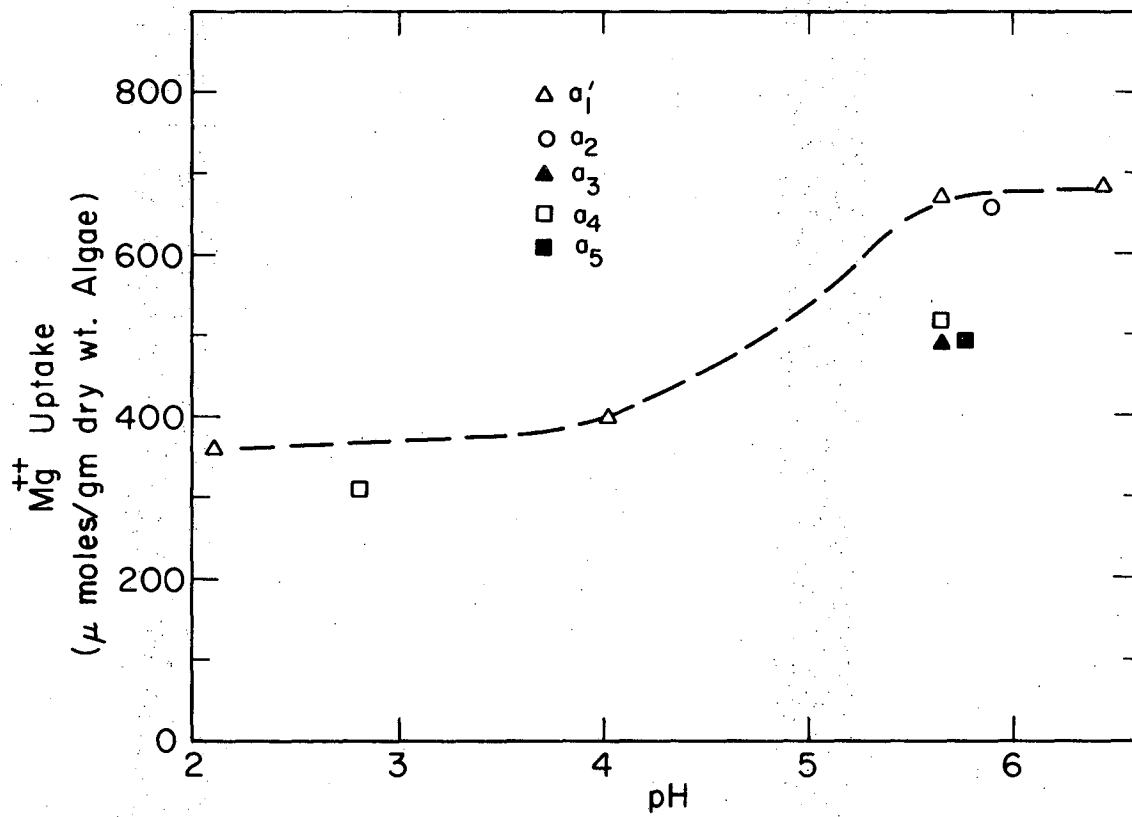

XBL7112-4990

Fig. 4. Mg⁺⁺ uptake data for Pandorina.

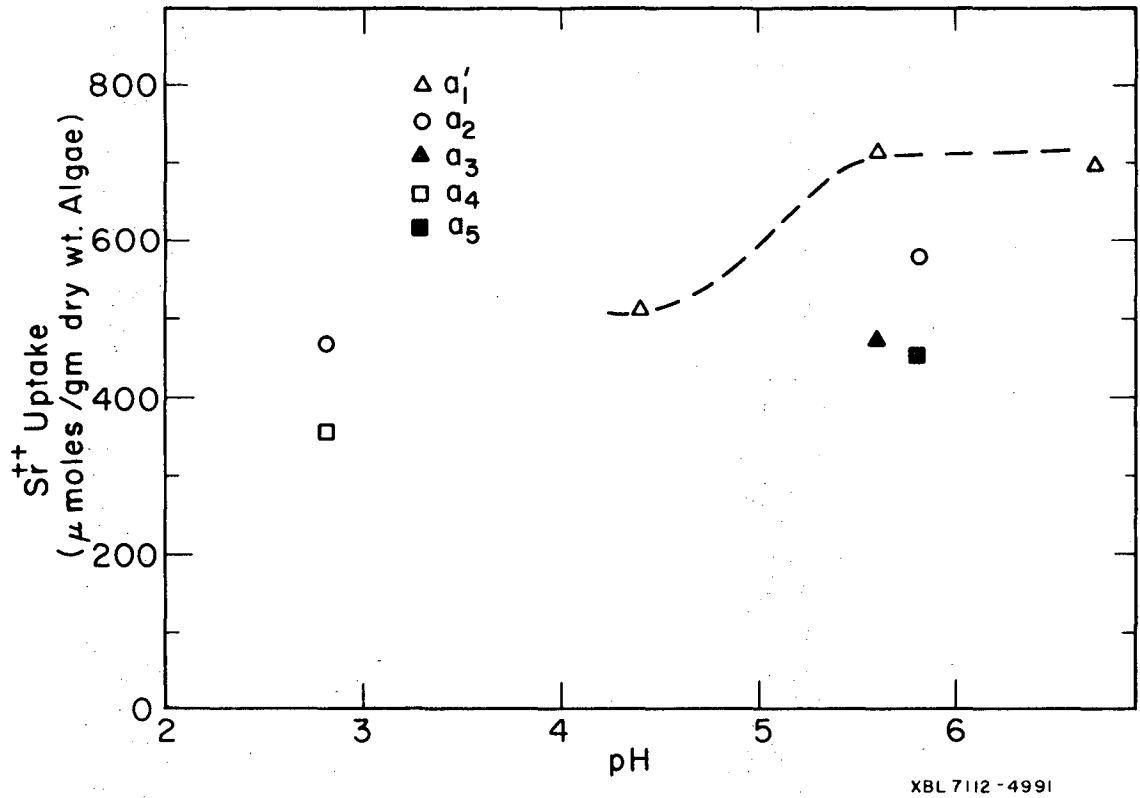

XBL 7112-4991

Fig. 5. Sr⁺⁺ uptake data for Pandorina.

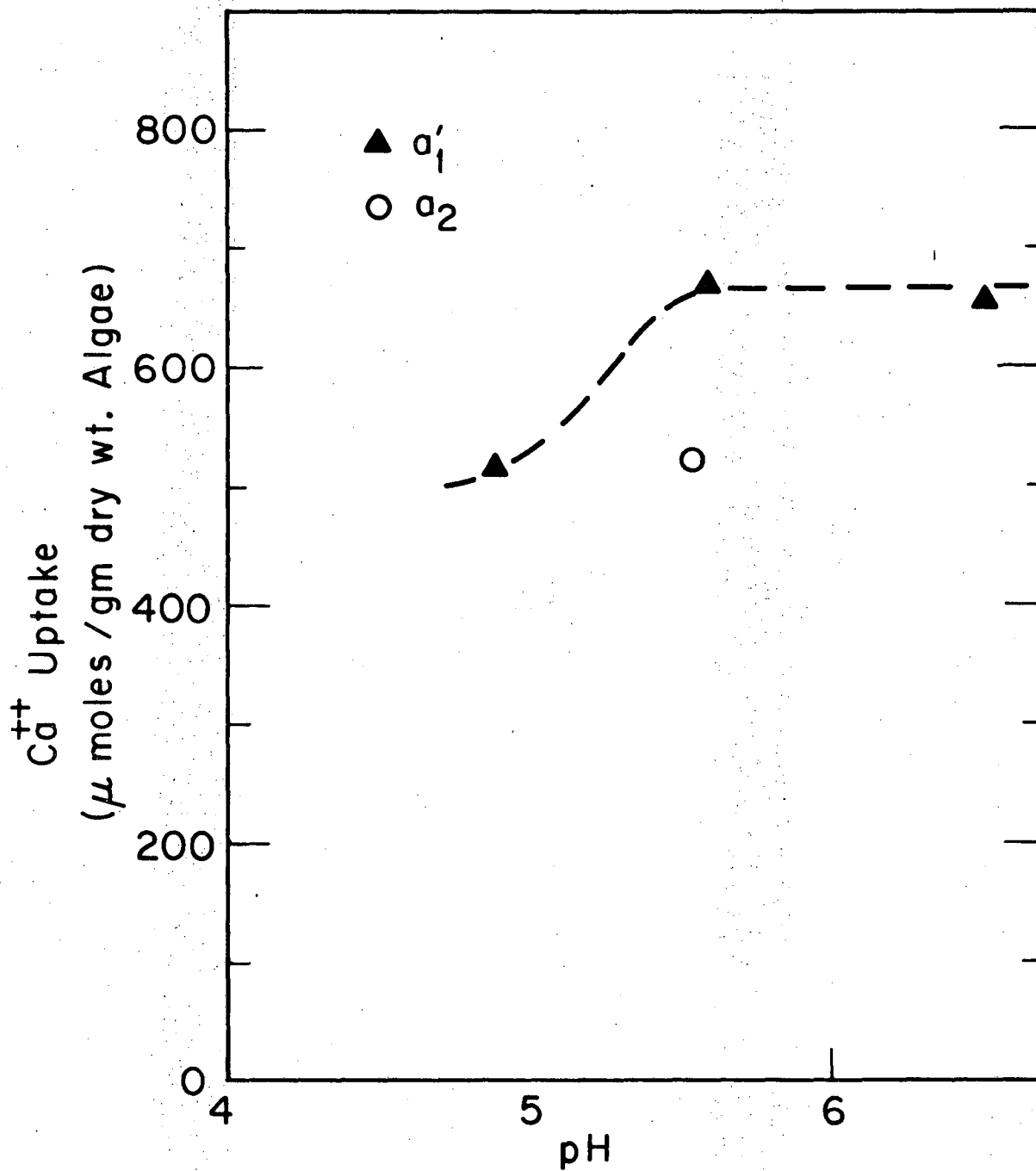

XBL7112 - 4993

Fig. 6. Ca^{++} uptake data for Pandorina.

resulting selectivity coefficients are listed in Table 2. We calculated the average values of:

$$1. \quad K_{Ca}^{Sr} = \frac{K_{Ca}^{Sr}}{K_{Ca}^{Ca}} = \frac{\frac{\text{meq Sr/gm dry wt algae}}{\text{meq Sr/ml solution}}}{\frac{\text{meq Ca/gm dry wt algae}}{\text{meq Ca/ml solution}}} \approx 1.2$$

$$2. \quad K_{Mg}^G \approx 1.8$$

$$3. \quad K_{Mg}^{Sr} \approx 2.2$$

Therefore, the algae appear to prefer $Sr^{++} > Ca^{++} > Mg^{++}$.

It should be noted that each K is a function of four measurements and that a 5% error in each measurement could lead to a considerable variation in the K value. Note that $K_{Ca}^{Sr} \cdot K_{Mg}^{Ca} = K_{Mg}^{Sr}$ gives a check on the data values.

5. Conclusions

To optimize our plant operation we will probably prefer to work with young vigorous cultures at pH's above 5.5. The values obtained for T (≈ 1.4 meq/gm dry wt algae) and K_{Ca}^{Sr} (≈ 1.2) were sufficient for a process evaluation study, which is reported in the next chapter.

F. Experiment 4 - Data Test

1. Purpose

We ran a staged exchange experiment to verify the assumption that $K_{Ca}^{Sr} = 1.2$ and $T \approx 1.4$ meq per gram dry weight algae could be used to predict the absorption characteristics of a process (i.e., to confirm that K_{Ca}^{Sr} and T obtained from Experiment 3 were correct and sufficient for a plant design).

2. Equipment

This experiment required Pandorina, Nalgene test tubes, 0.5 M $CaCl_2$ and 0.0775 M $SrCl_2$ solutions, and drying, ashing, and atomic absorption

equipment.

3. Procedure

Algae for this experiment were prepared simultaneously with those for set 6 of Experiment 3, using the same preparation pre-washing procedure. However 0.5 M CaCl_2 was substituted for the 0.5 M MgCl_2 pre-solution. Then equal aliquots of the algae were transferred to each of six 40 ml Nalgene centrifuge tubes (see Fig. 7 for flow sheet). The tubes were centrifuged and the supernatant fluids were removed. Thirty milligrams of 0.0775 M SrCl_2 wash solution was added to each, and the tubes were arranged with three "stages" in each of two series. After two minutes agitation via Vortex mixers followed by centrifugation, all six supernatants were transferred in the following way: supernatants from the 3rd stage were held for analysis, those from the 2nd stage were transferred to the 3rd stage, those from the 1st stage were transferred to the 2nd stage; and then 30 ml of fresh SrCl_2 was added to the 1st stage. The tubes were then agitated and centrifuged again, and the whole process was repeated ten times. Finally, all supernatants were taken for analysis, and the remaining algae in each stage were ashed and analyzed.

A computer program (see Appendix C) was written to predict the outcome of this experiment. The program used $T = 1.45$ and $T = 1.35$ meq per gram dry weight algae and $K_{\text{Ca}}^{\text{Sr}} \approx 1.2$ (i.e., $D = 1.2$). The computer predictions are given in Table 3. The data are presented in Appendix C.

4. Results

The computer and experimental results are compared in Figs. 8 and 9. Note that barring experimental scatter, results seem to be mutually confirming. The plateaus given in Figs. 7 and 8 are dependent on the values of T assumed

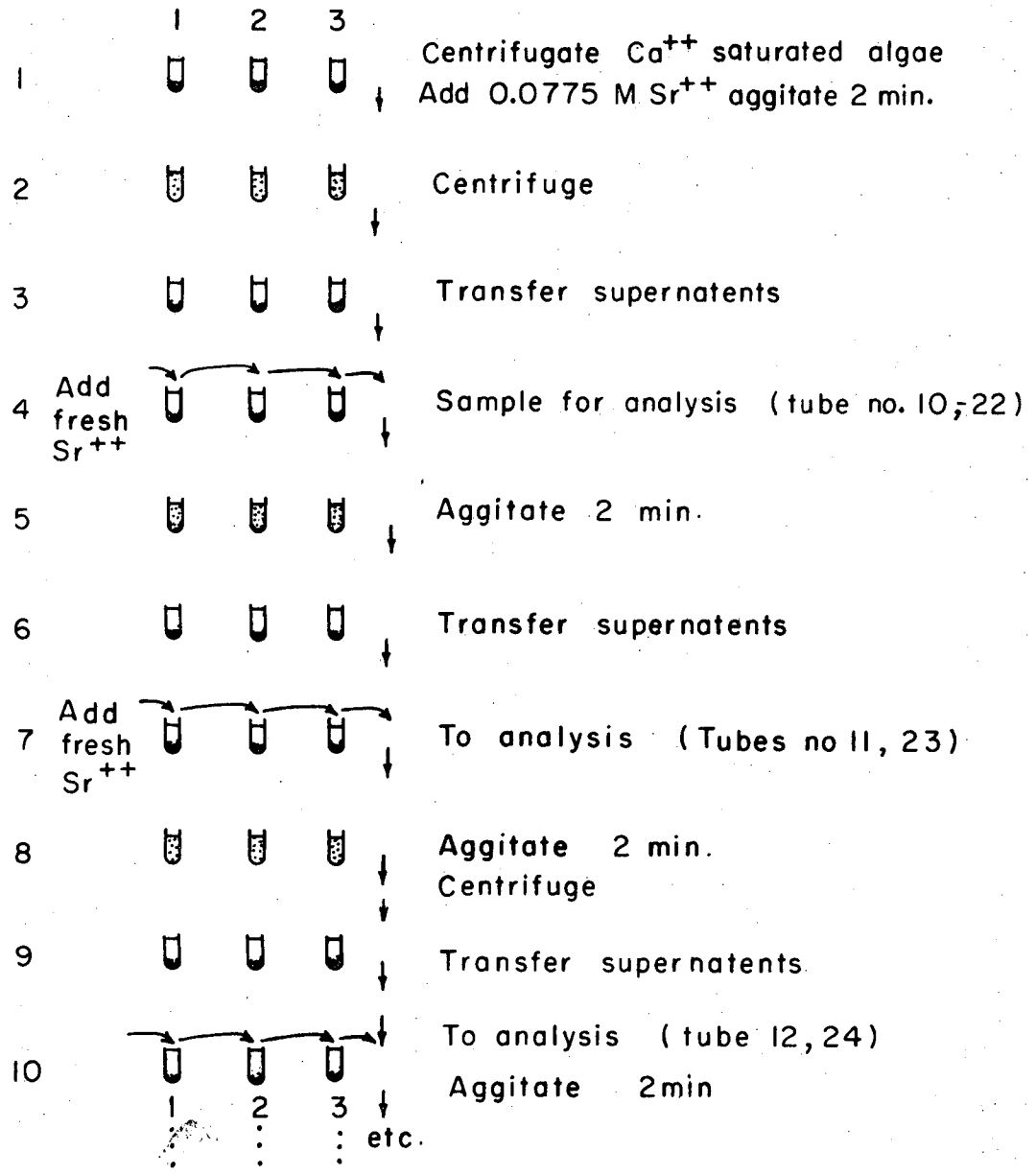

XBL7112 - 2101

Fig. 7. Data test - flow sheet.

EXPERIMENT 4

TABLE 3. Ion Concentration in Equilibrium Solutions

Tube #	Results - 1st Set			Tube #	Results - 2nd Set			Computer Predictions (T = 1.45, K = 1.2)		
	Ca meq./cc	Sr meq./cc	Ca+Sr (meq./cc)		Ca meq./cc	Sr meq./cc	Ca+Sr (meq./cc)	Ca (meq./cc)	Sr (meq./cc)	Ca+Sr (meq./cc)
10*	3.75	3.76	7.51	22	4.84	3.74	8.58	4.03	3.72	7.75
11	3.90	3.74	7.64	23	4.77	3.78	8.55	4.03	3.72	7.75
12	3.77	3.98	7.75	24	4.77	3.74	8.51	4.03	3.72	7.75
13	2.19	4.25	6.44	25	2.42	4.27	6.69	3.39	4.36	7.75
14	1.84	5.19	7.03	26	2.06	5.12	7.18	2.56	5.19	7.75
15	1.55	6.01	7.56	27	1.54	5.71	7.25	1.76	5.99	7.75
16	1.00	6.61	7.61	28	1.04	6.55	7.59	1.12	6.63	7.75
17	0.74	6.84	7.58	29	0.75	6.59	7.34	0.68	7.07	7.75
18	0.50	7.23	7.73	30	0.53	7.24	7.77	0.39	7.36	7.75
19	0.30	7.66	7.96	31	0.36	7.16	7.52	0.22	7.53	7.75

* Results are listed in the order in which supernatants were obtained from the third stages of each set.

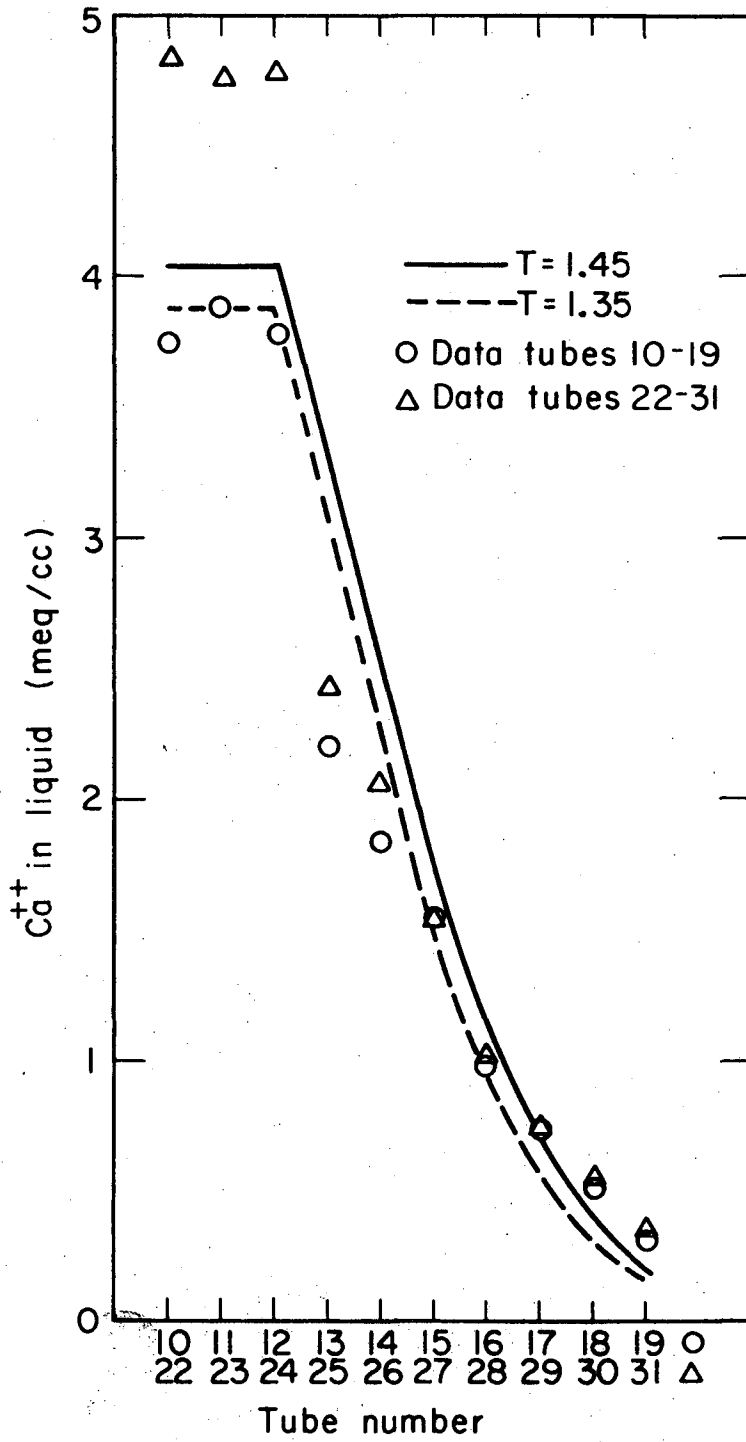

XBL7112-4997

Fig. 8. Comparison of computer predictions and experimental results.

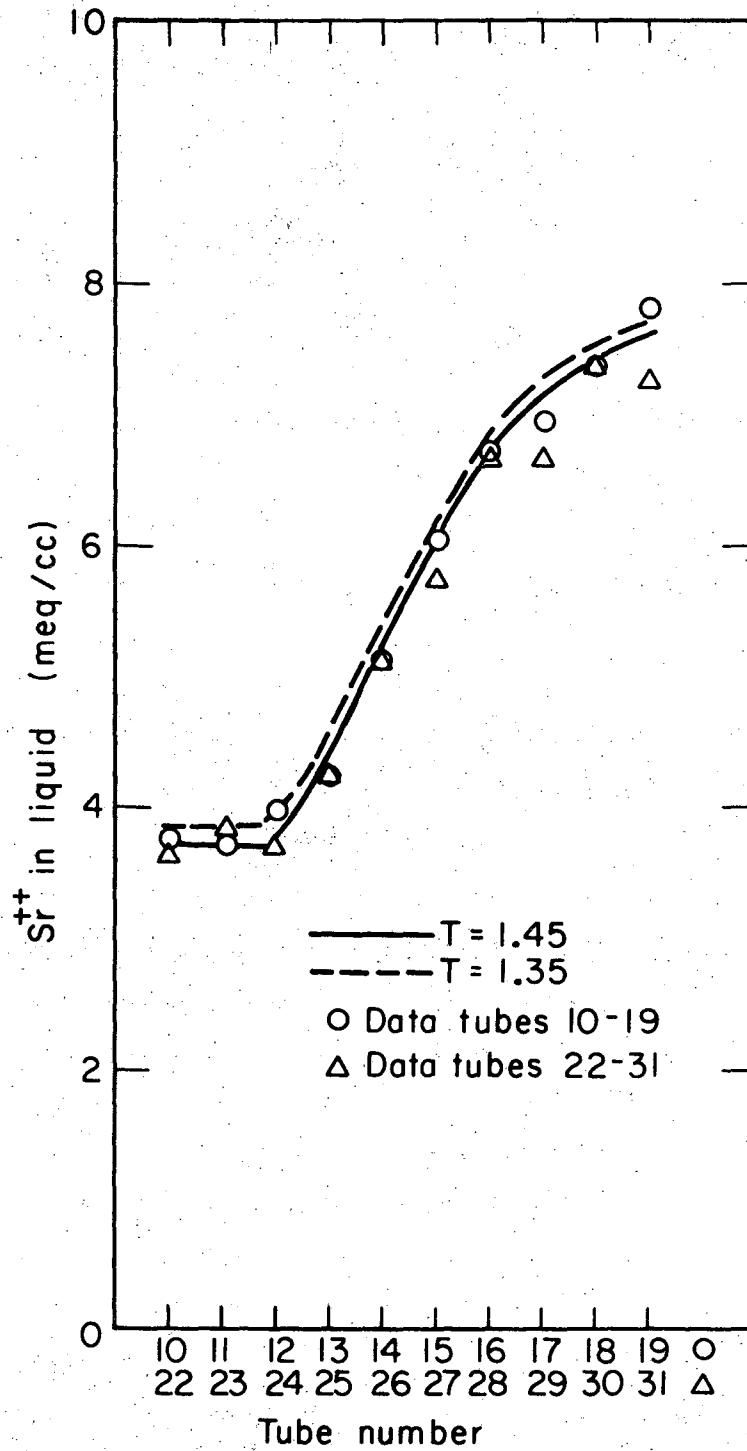

XBL 7112-4998

Fig. 9. Comparison of computer predictions and experimental results.

in the computer program calculation. The shape of the curves obtained from the computer program are determined by assuming $K_{Ca}^{Sr} = 1.2$. We note that excluding experimental scatter, the program results fit the data.

5. Conclusions

The values at $K = 1.2$ and $T = 1.4$ meq per gram dry weight algae, which were derived in Experiment 3 will be sufficient for the process design and evaluation to be carried out in Chapter IV.

IV. WATER PURIFICATION - ECONOMIC EVALUATION

A. Introduction

Economic evaluation of the algal low level radioactive waste clean-up process is based on a comparison with an Oak Ridge pilot plant "Ion-Exchange Scavenging Precipitation" process*, which required that radioactive Sr be reduced by at least a factor of 1000, and produced cost estimates for a 750,000 gallons per day treatment plant. First we give a brief outline of the Oak Ridge process followed by a description of two variations of our algal clean-up process. We then present the cost analysis for the algal clean-up process using criteria similar to those used in the Oak Ridge process whenever possible. Finally we compare the costs of all processes we are considering, and discuss our conclusions.

B. Description of the Oak Ridge "Ion-Exchange Scavenger Precipitation" Process

The Oak Ridge process (see Fig. 10) employs an ion exchanger supported by other unit operations designed to maximize the overall removal

* For process, water was similar to tap water containing 109 ppm of total hardness as equivalent CaCO_3 . The concentration of radiation was reduced to less than 2% of the 168 hour MPC_w (maximum permissible concentration of radioactivity in environmental water).

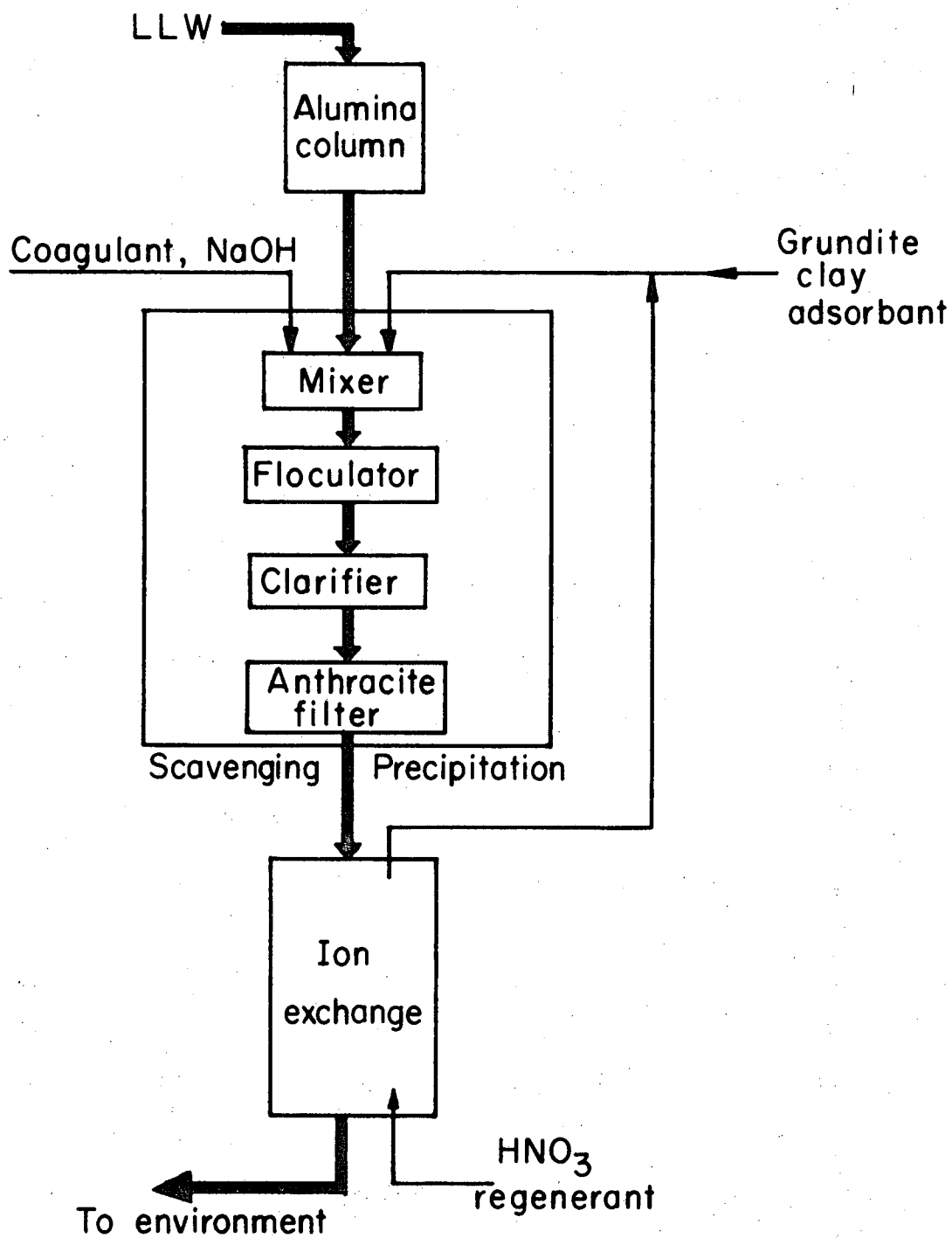

XBL7112-2107

Fig. 10. Flow sheet for the Oak Ridge "Ion Exchange Scavenger Precipitation Process".

of radioactive Sr^{++} . The process begins with alumina treatment of the radioactive waste stream for the removal of phosphate, followed by a "Scavenger Precipitation" process designed for removal of Ca^{++} and Mg^{++} and colloids. Removal of phosphate improves the efficiency of the scavenging precipitation process; removal of Ca^{++} , Mg^{++} and colloids improves the efficiency of the ion exchanger for adsorbing Sr^{++} .

"Scavenger Precipitation" describes a process in which the pH adjustment with NaOH and the addition of a coagulant (Copperas), result in a precipitate containing large flocs which trap (scavenge) or adsorb smaller precipitated particles. pH Adjustment and coagulant addition take place in a flash mixer. The suspension is agitated gently in a flocculator, and solids are then removed in a clarifier stage. Remaining fine precipitates are removed by passing them through a bed of anthracite absorbant.

Liquid is then processed by an ion exchange column. The ion exchanger is regenerated with nitric acid which is then mixed with Grundite clay absorbant and recycled to the scavenger precipitation units. Radioactive material leaves the process as solid products produced by the clarification and anthracite bed stages, and are then buried in polyethylene lined fiber drums at a cost of 57¢ per cubic foot. The authors of the Oak Ridge process report concluded that the "Ion-Exchange Scavenger Precipitation" process is an economic, high decontamination process for removal of fission products from the Oak Ridge National Laboratories low level radioactive waste stream. Furthermore, they state that the process is practical, uses methods similar to standard water treatment practices, and is capable of treating 750,000 gallons per day of water for between 60¢ and 75¢ per 1000 gallons. A summary of estimated costs is presented in Table 4.

Estimated Cost of the Oak Ridge
"Ion-Exchange Scavenger Precipitation" Process *

TABLE 4. The basis for all estimates is a 750,000 gallons/day treatment plant. All costs are in cents/1000 gallons of waste fed to the process.

	<u>¢ Costs</u>	<u>Total ¢ Costs</u>
A. Fixed Costs		35.80
Utilities	1.0	
Labor	17.28	
Amortization*	12.88	
Maintenance	8.57	
B. Precipitation Chemicals Costs		13.53
C. Resin Regeneration Chemicals Costs		14.36
D. Alumina Treatment Costs		3.79
E. Waste Handling Costs		9.90
	TOTAL	<u>74.6 ¢</u>

* Capital Equipment costs are \$469,000 and are amortized at 4% over a 20 year period.

C. Description of the Algal Clean-Up Process

1. Introduction

Two variations are presented of a possible process for utilizing algae to remove radioactive Sr from low level waste streams (LLW). Other variants might be considered but it is likely that they would all include the same basic features. All algal clean-up process designs will probably include schemes for preparation of algae, for contacting them with the contaminated waste stream, and for either disposal or recovery of the contaminated algae. Fig. 11 is a layout for the two process variations considered. The process involving direct disposal is called "Single Pass" and the process which regenerates and reuses algae is called "Recycle". Material balances presented in Fig. 11 are the results of a computer optimization program presented in Appendix B.

2. Preparation of Algae

Algae for the process can be grown in an open pond by methods described in Chapter V and Appendix 1 of this paper. We need to select organisms from the pond that can be easily handled when they are in the section of the process where they contact the contaminated waste stream. One way to insure the separability of the algae coming from the pond is to have a stage in which the more separable organisms are removed from the bulk of the media. Here we would use the same kind of separation device that would be employed in the contactor section.

3. Contacting the Contaminated Waste Stream

In the absence of a technique for creating a fixed bed of algae, we probably have to rely on a series of mixing stages to bring the algae in contact with the radioactive waste. Each stage will include a mixing section

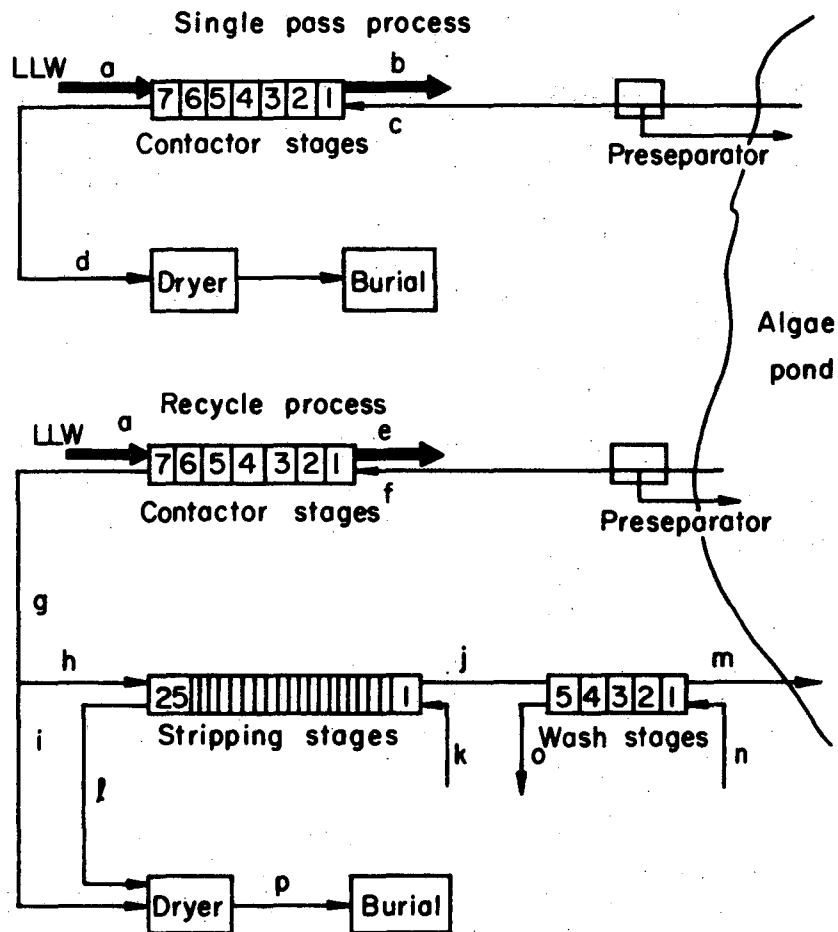

XBL 7112 - 2106

Fig. 11. Two Algal LLW Clean-up Process Variations. Basis - 1000 gallons of LLW Processed every 2 minutes.

Stream	#'s H ₂ O	#'s Algae Dry Wt	Units Sr ⁺⁺	#'s Ca
a	8000		1000	
b	8002.5	0.25	0.67	
c	250	25.		
d	247.5	24.75	999.33	
e	8002.5	0.25	0.67	
f	250	25	small	small
g	247.5	24.75	999.33	
h	222.7	22.27	899.4	
i	24.7	2.47	99.9	
j	220.4	22.04	0.2	31.2
k	313.6			78.4
l	315.8	0.22	899.2	47.2
m	218.2	21.82		
n	3780.0			
o	3782.2	0.22	0.2	31.2
p	340.5	2.69	999.33	47.2

in which the algae are agitated with the LLW stream and then a separation section in which an algae concentrate is again recovered. A sample flow sheet for 4 contactor stages is presented in Fig. 12. Separation of many of the smaller green algae from bulk liquid streams presents a variety of difficulties. These difficulties are discussed in Chapter V.

When centrifuges are used as the separation device for each stage, we have to compensate for the inefficiency of separation in our calculations. (In the computer program, the fraction of material not separated in each centrifuge stage is estimated to be 0.01 and is denoted by the constants "S, SS, and SSS.") The maximum throughput of the largest industrially available centrifuge⁹ is between 250 and 300 gallons per minute. We would need, therefore, two parallel centrifuges for each stage of a 750,000 gallon per day plant. As in many other types of staged mass transfer processes, a countercurrent arrangement of stages will optimize the mass transfer situation.

The equilibrium in each stage will be determined by the concentration of Ca^{++} and Mg^{++} in the bulk liquid, by the total number of absorption sites and by the value of the selectivity coefficients* for Sr^{++} relative to Ca^{++} and Mg^{++} . The mathematics used to evaluate the two algal clean-up process variations is presented in Appendix C.

4. Direct Disposal of Algae versus Recycle of Algae

Pandorina, having picked up radioactive Sr in the contactor section of the process can then be either disposed of or "cleaned-up" and recycled.

In process variation 1 presented in Fig. 11, the algae are dried with a rotary dryer and then buried in polyethylene lined fiber drums.

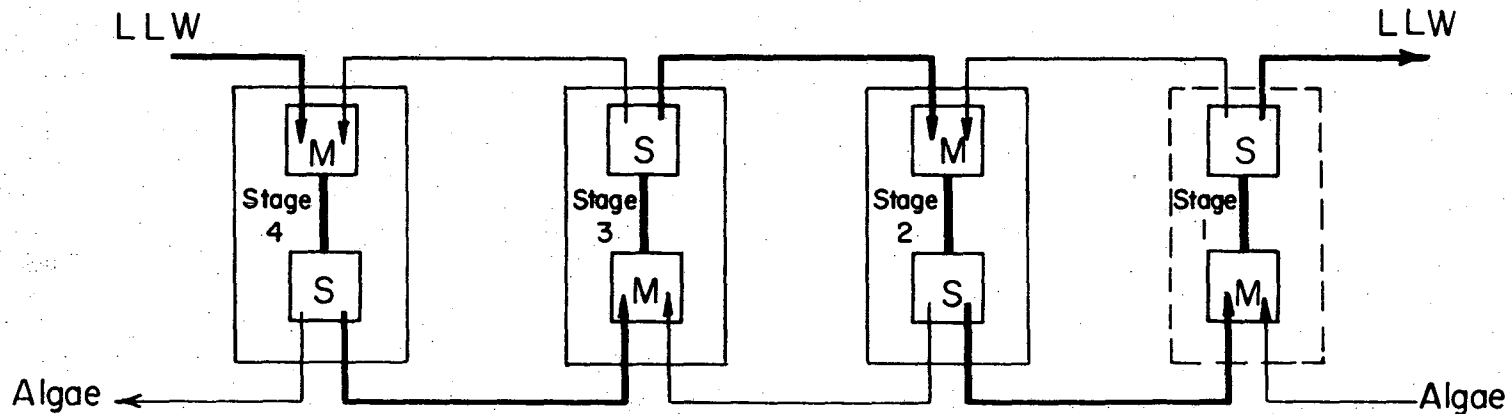

XBL7112-2104

Fig. 12. Flow Diagram of 4 Contacting Stages.

- S Represents a separator, i.e., a centrifuge or two centrifuges in parallel. Algae leave in the underflow and the bulk liquid stream leaves through the overflow.
- M Represents a mixing tank with a two minute holdup volume to allow equilibrium of algae and LLW streams. If Phototactic Separators were used, flow rates would be slow enough to eliminate the need for mixing tanks.

In process variation 2 also outlined in Fig. 11, only a small bleed stream is dried and buried. The bulk of the algae are stripped of Sr^{++} in a stripping section by contacting them with a concentrated CaCl_2 solution in a series of stages (n. b. equilibrium is determined by Equation 1). The CaCl_2 solution is then evaporated and buried. The algae leaving the stripping section are still in a CaCl_2 rich solution. In order to keep Ca^{++} from building up during the process, the algae are washed following the stripping section with tap water in a series of stages (wash section) and then returned to the pond.

D. Cost Analysis of the Algal Clean-Up Process

Design and cost calculations comprise a very approximate estimate to provide general perspective on the economic feasibility of the process. More detailed calculations were considered unnecessary at this stage of the development in view of the many uncertainties in the processing steps and generally unfavorable costs.

Table 5 contains the cost estimate optimization results obtained with the aid of the computer program shown in Appendix C. The results correspond to the flows indicated in Fig. 9.

1. Basis of Calculation

- a) We carry out all calculations on the basis of 1000 gallons of low level radioactive waste (LLW) processed. (The same basis that was used in the Oak Ridge cost estimate.)
- b) A 750,000 gallon per day plant processes 1000 gallons of LLW in two minutes. Therefore, quantities presented in Fig. 9 are per 2 minutes of operation.

2. Capital Costs

The largest industrially available centrifuges⁹ are capable of pro-

cessing 250 - 300 gallons per minute and have an installed cost of \$200,000. Two centrifuges operating in parallel are required to process 1000 gallons of LLW in two minutes. A \$200,000 centrifuge amortized over 20 years at 4% interest, costs approximately 5¢ per 500 gallons of LLW processed. A bank of two parallel centrifuges in a stage of the contactor section will cost approximately 10¢ per 1000 gallons LLW processed. In addition, each stage may require a holding tank of 1000 gallon capacity to provide two minutes holding time for mixing and equilibrium of algae and LLW. The cost of each tank, if required, will be negligible in comparison to the cost of a centrifuge. The cost of each tank will be approximately \$4000. In the case of algal recycle, stripping and drying section stages will each contain one centrifuge.

The Single Pass process requires a 30,000 rotary dryer¹⁰ (\$30,000 installed cost) to process 24.75 pounds dry weight algae and 247.5 pounds of water every two minutes. The recycle process rotary dryer costs about \$40,000 and processes 2.47 pounds of dry weight algae, 47.2 pounds CaCl_2 and 340.5 pounds. The total capital cost of the Single Pass process is \$2,682,000 or \$6.75 per 1000 gallons LLW processed. The total capital cost of the recycle process is \$9,012,000 or \$2.25 per 1000 gallons of LLW processed.

3. Fixed Costs

Fixed costs include labor, maintenance, utilities and amortization of capital. Labor for the Single Pass Process includes one operator full time (168 hours/week, 52 weeks/year) at \$3.00 per hour with surcharges of 10% for supervision and 70% for overhead. Labor for the recycle process is exactly that of the Single Pass process. Maintenance is estimated at 5% of

capital investment per year. The amortization of the capital investment is over a 20 year period at 4% interest. Utilities are estimated to be 0.4¢ per kilowatt hour.

4. Chemical Costs

We consider the algae entering the process and the CaCl_2 used in the stripping section to be the two chemicals required by the algal clean-up process. The cost of producing algae⁹ is estimated to be 2¢ per dry weight algae produced. The cost of CaCl_2 ¹¹ is estimated at \$40 per ton CaCl_2 or 2¢ per pound.

5. Waste Handling Costs

Algae and CaCl_2 leave the rotary dryers rich in radioactive Sr. They are buried in polyethylene lined fiber drums at a cost of 57¢ per cubic foot. We estimate the cost of handling and disposal to be approximately 1¢ per pound dry weight of material disposed. In the Single Pass process algae leave the contacting section and are then dried and disposed of directly. In the case of Algal Recycle, 10% of the algae stream leaving the contactor section is bled for drying and disposal. The CaCl_2 solution used to strip radioactive Sr from the remaining 90% of the algae stream is combined with the bleed stream, dried and buried.

E. Results and Conclusions

The results of the cost analysis of the two algal clean up process variations are presented in Table 5. The Single Pass Process and the Algal Recycle process are estimated to cost, respectively, \$2.24 and \$6.75 per 1000 gallons of low level waste processed. The recycle process is more expensive than the simpler Single Pass Process. This is due to the fact that it costs approximately 20¢ to regenerate 2¢ worth of algae via recycle.

COMPARISON OF ESTIMATED COSTS OF Sr⁺⁺ REMOVAL PROCESSES

TABLE 5. The basis for all estimates is a 750,000 gallons/day treatment plant.
All costs are in cents/1000 gallons of waste fed to the process.

	ALGAL PROCESSES		Oak Ridge Process
	Single Pass	Recycle	
A. Fixed Costs	<u>148.98</u>	<u>461.56</u>	<u>35.80</u>
Utilities	15.00	31.00	
Labor	17.28	34.56	
Amortization*	65.70	225.00	
Maintenance	51.00	171.00	
B. Chemical Costs	<u>50.00</u>	<u>163.5</u>	<u>31.68</u>
Algae	50.00	6.5	
CaCl ₂		157.00	
C. Waste Handling Costs	<u>24.75</u>	<u>49.7</u>	<u>9.90</u>
Algae	24.75	2.5	
CaCl ₂		47.2	
	<u>TOTAL</u> <u>223.73</u>	<u>674.76</u>	<u>74.6</u>

* Capital Equipment costs are \$2,682,000 for Single Pass, \$9,012,000 for Recycle and are amortized at 4% over a 20 year period.

The cost of the purchase and disposal of CaCl_2 make the Recycle Process prohibitively expensive. The Single Pass algal clean-up process at \$2.24 appears substantially more expensive than the 74.6¢ Oak Ridge Ion Exchange Scavenger Precipitation Process. However the cost of the Single Pass Process could be substantially reduced in the following ways: First, by replacing centrifuges with an inexpensive means of separation, we could reduce the enormous capital investment cost. Phototactic Separators, if industrially feasible, might provide the inexpensive means of separation required. Second, a large scale algal agriculture would result in an available supply of algae at less than 2¢ per pound. This would further help reduce costs of a Single Pass Process. Finally, if a safe technique for ashing radioactive algae were developed, the volume of the waste and the resulting disposal cost could be reduced. However, even with these savings it appears unlikely that an algal process could compare favorably with the ion exchange process.

V. PHOTOTACTIC SEPARATION

A. Introduction

Phototactic response describes the tendency of motile algae (able to swim) to orient themselves and swim directly towards a light source. We define "Phototactic Separation" as a process which utilizes the phototactic response of organisms to effect their separation from a liquid suspension.

In Chapter V we describe the successful operation of a laboratory scale "Inclined Wall Phototactic Separator". We begin with a brief general discussion of the problems of concentrating (harvesting) algae. This is followed by a description of the initial exploratory phototactic experiments and a presentation of the design of an Inclined Wall Phototactic Separator along with the results of an experimental investigation of this device. We conclude with a discussion of the problems of scaling up a Phototactic Separator to an industrially useful size.

B. Background

Small green algae are potentially an attractive food source (see Chapter VI) and *Pandorina morum* interested us in particular because of its ion exchange properties (Chapters III and IV). However the small green algae tend to grow in very dilute suspensions and according to Oswald et al., the initial concentration step is expensive. Standard techniques of separation are either expensive or ineffective when applied to concentration of algae. For example, filtration fails because the small algae deform and rapidly plug filter pores. Settling is ineffective because some organisms have a density close to that of water and others swim randomly in order to stay in solution. Centrifugation is an expensive process and requires that a supply of denser-than-water organisms be insured. Keeping denser-than-water organisms dominant in an open culture is discussed in the last section of this Chapter. In view of the difficulties discussed above, the concept of algae swimming towards the nearest wall and collecting themselves, in response to the stimulus of a light, in a device with no moving parts becomes an interesting idea.

Chlorella (5 μ diameter) stay in suspension by a combination of brownian motion and a density of nearly 1. *Chlamydomonas* (15 - 20 μ diameter) and the sixteen celled *Pandorina* (30 - 50 μ diameter) stay in suspension by swimming. This swimming or motility is produced by the coordinated action of rapidly moving flagella. These motile algae have eye spots which are light sensitive enabling the organisms to locate and swim directly towards

a light source. This mechanism differs from the corresponding mechanism in phototactic bacteria in which gradients are recognized and random steps taken to insure a swimming direction which will coincide with increased light absorption.

C. Exploratory Investigations and Development of Equipment

1. Beaker Experiments

The first experiments consisted of suspending various species of motile algae in dilute solution in ordinary 400 ml beakers in a dark room and shining a flashlight through one side of the beaker. It was noted that the algae would swim to the wall nearest the light and then, when their density (these algae were slightly denser than water) led to a hydrodynamically unstable situation, they fell down the wall in a dense mass. By holding the light first to one side of the beaker and then to the wall opposite, crude estimates of the various swimming rates were observable. On the basis of those early observations *Pandorina morum*, with a swimming speed of 1 - 2 cm per second, was chosen as the organism for our investigation of Phototactic Separation.

2. Horizontal Channel Experiments

The second generation apparatus (see Fig. 13) consisted of a 28 cm long channel (5 cm wide) with distributed inlet at one end and a 1 cm high weir at the other. The algae were to enter, be concentrated on the top by means of an overhead light source, pass over the weir and leave through a one exit line while the bulk flow, devoid of motile organisms exited under the weir. A small mesh wire grid was placed perpendicular to the direction of flow 2 cm from the inlet to help smooth the flow profile and reduce secondary flows. The difficulties experienced with this device were as follows:

- a) Organisms collecting at the top fell to the bottom in occasional

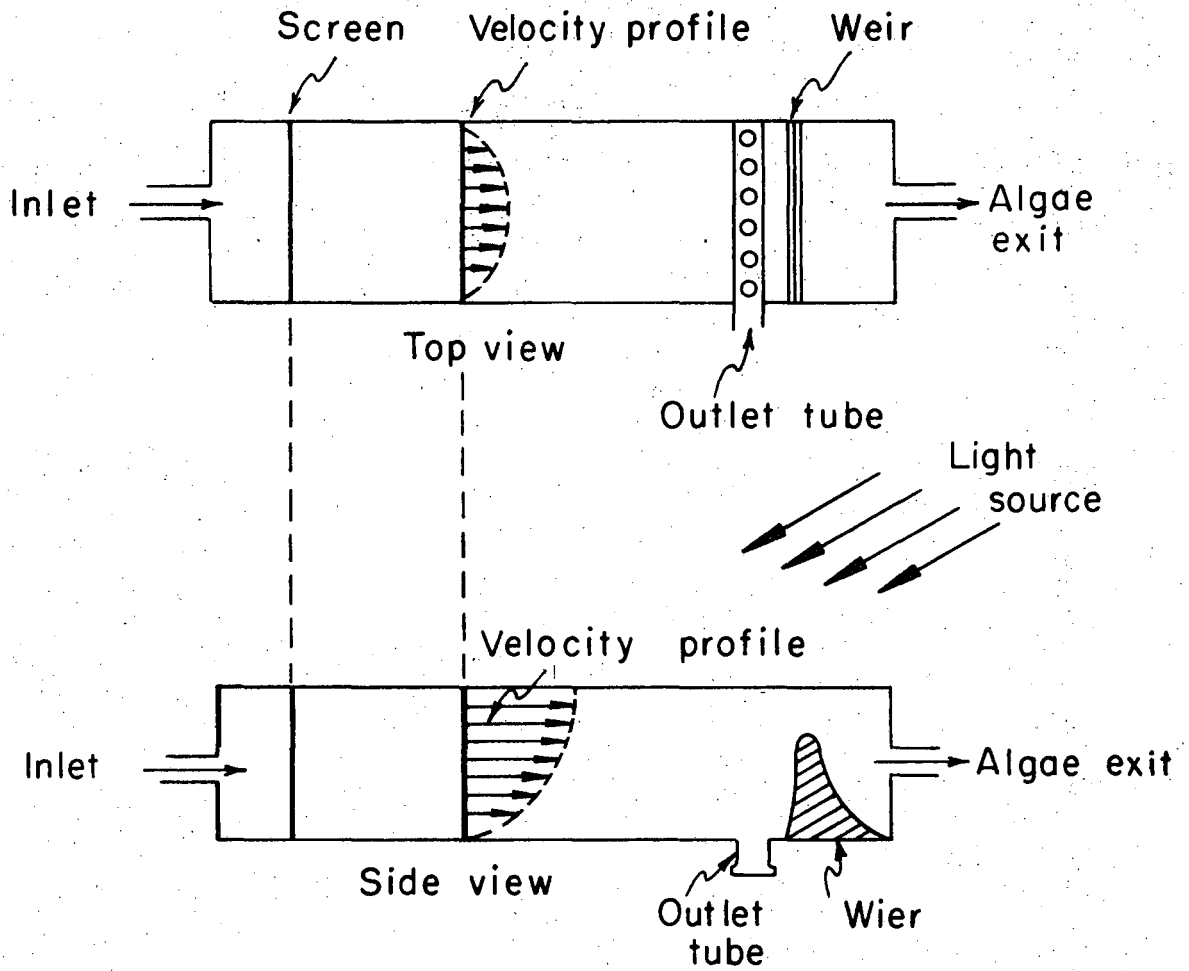

XBL7112 -2105

Fig. 13. The horizontal channel phototactic separator.

clumps due to hydrodynamic (density) instability before they could pass over the weir.

b) Surface tension effects and low flow rates resulted in an insufficient and erratic dribbling over the weir.

To solve the second problem (b), a smooth continuous flow over the weir was created by instituting a controlled flow situation which backed up and maintained a few millimeters of liquid height over the weir at all times.

To combat the first problem (a) of algae leaving the surface before they reached the weir, we rearranged the lighting to attract all the motile organisms to the bottom of the channel. This resulted initially in a fairly "algae free" solution passing over the weir, but a very steady build-up of organisms trapped in an almost zero flow rate region at the bottom.

It then became necessary to clear the bottom, both in order to collect the algae and to permit light to continue to penetrate to the upper layers of solution. Since we were reluctant to use moving parts (e.g., a mechanical moving belt or sweeper), we chose the idea of inclining the plane of the bottom. Practical considerations led to the next generation device: a closed rectangular channel.

3. The Inclined Wall Phototactic Separator

The Inclined Wall Phototactic Separator is described pictorially in Fig. 14 from both front and side views. Note that the thin arrows denote bulk liquid flow, while the heavier arrows approximate the path of the dense algae rich fluid. The flow in this device appeared to be laminar in all regions, under all conditions of operation investigated in this experiment. A secondary flow existed near the bottom of the unit due to the force of the inlet feed jet, and is described by the circular arrow. The quantity of sludge

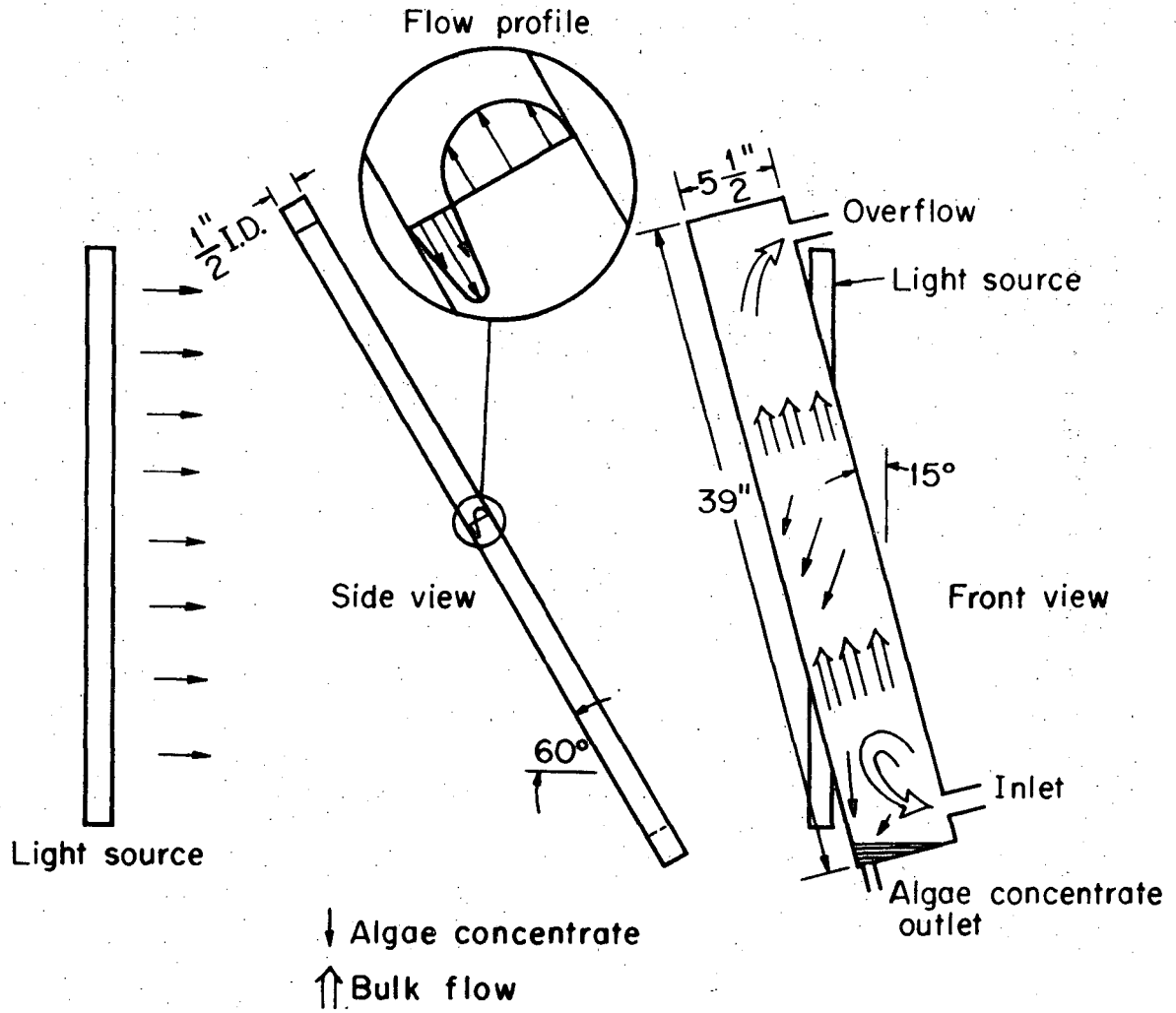

XBL7112-4999

Fig. 14. The Inclined Wall Phototactic Separator.

(concentrated separated algae) being removed was always very much less than the bulk overflow and therefore, the region below the feed inlet could be approximated as nearly "stagnant". As a result of the quiescence of the sludge region, very little separated material ever returned via the fast inlet flow to the main separation regions.

Light entered the separator through the lower of the two inclined flat walls. The resulting density induced flow (see arrows on flow diagram in Fig. 11) did not come into conflict with the upward bulk stream but rather carried the algae directly downwards towards the sludge removal section.

The column was held vertically then rotated 30 degrees around one horizontal axis and then 15 degrees around a second perpendicular horizontal axis. This secondary tilt led to a slight change in the settling flow and seemed to expedite the concentration of the algae. The 15 degree inclination was also useful in permitting the settling algae to avoid the inlet jet. A further mechanism for avoiding possible flow turbulence problems in the entrance region of a slightly larger separator would be to make the cross section of this region wider than that of the upper end of the channel and to utilize multiple inlet jets.

D. Experiments with the Inclined Wall Phototactic Separator

1. Preparation of Organisms

Pandorina morum were produced in a continuous growth chamber (falling film cooled flat reactor) which was operated with medium Formula B at a dilution rate of 0.0125 hr^{-1} with 4% CO_2 in air at 20°C , and an average light intensity of 350 footcandles (see Appendix I). The suspension when harvested contained only a small fraction of motile organisms which was probably due to the continuous lighting of the chamber which differs from the

normal diurnal cycle.

A 1.5 liter batch of algae was removed from the growth chamber. Small quantities of calcium and magnesium salts were added, and then the *Pandorina* were aerated in the dark at 20°C for 12 hours. As a result of this treatment, about 85% of *Pandorina morum* were motile for the tactic runs.

2. Procedure

The algal feed, diluted to about 10 liters with water, was fed from a constant head bottle to the inlet of the separator. The overflow was collected in a graduated cylinder and flow rates were computed with the aid of a timer. Concentrations of *Pandorina* were monitored by measuring the overflow optical density (O. D.*). The sludge rate removal was negligible and was normally controlled with the aid of a clamp. In each run, the column was started empty and the low rate was allowed to decrease in an uncontrolled manner as the column filled. Usually about 10 minutes elapsed before the first sample could be collected and by this time the necessary flow patterns for separation started to take form.

Three experiments were run at similar flow rates. One with the light on; one with the light off; and one with the light initially off and then turned on.

3. Results

Figs. 15, 16 and 17 present the results of the three experimental runs. Each Figure contains a plot of the fraction of the organisms in the overflow (i.e. unseparated organisms) and the fraction of motile organisms in the over-

* To calculate the dry weight *Pandorina* from O. D., the *Pandorina* were centrifuged in a low speed centrifuge and the O. D. of the remaining solution (Bacteria O. D.) served as a blank. Subtraction of the Bacteria O. D. from the total O. D. yielded a number which could be compared with a calibration of O. D. versus *Pandorina* dry weight.

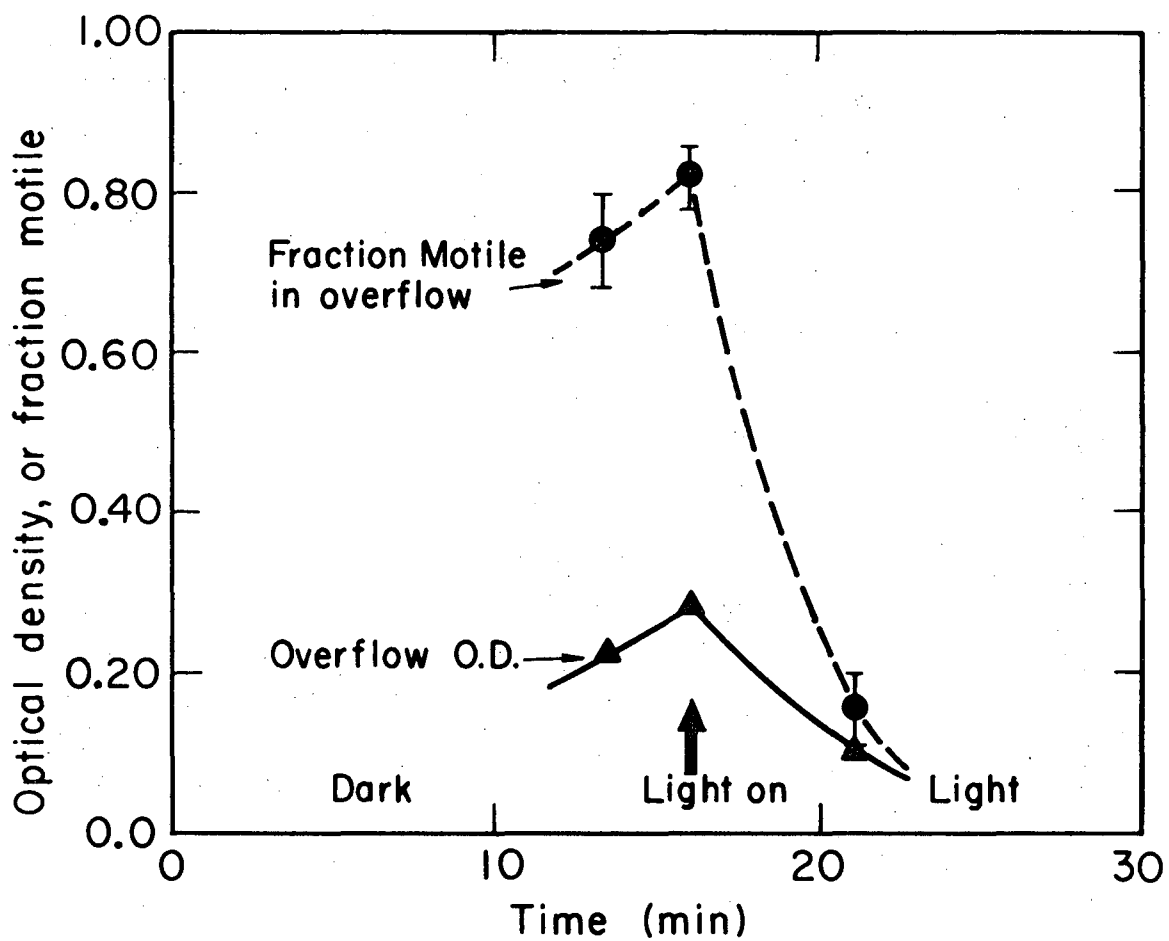

XBL7112-4994

Fig. 15. Phototactic separation run 1. Feed O.D. = 0.47, overflow rate = 160 ml/min.

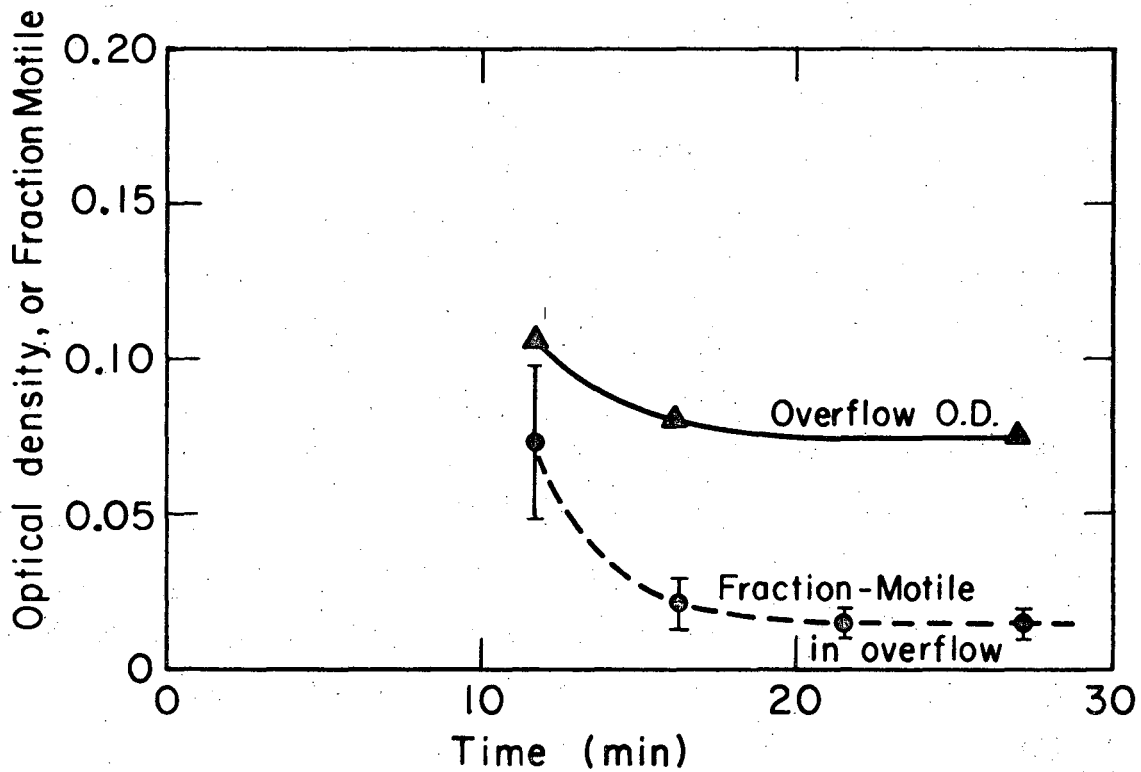

XBL 7112-2102

Fig. 16. Phototactic separation run 2. Light On,
Feed O.D. = 0.47, overflow rate = 135 ml/min.

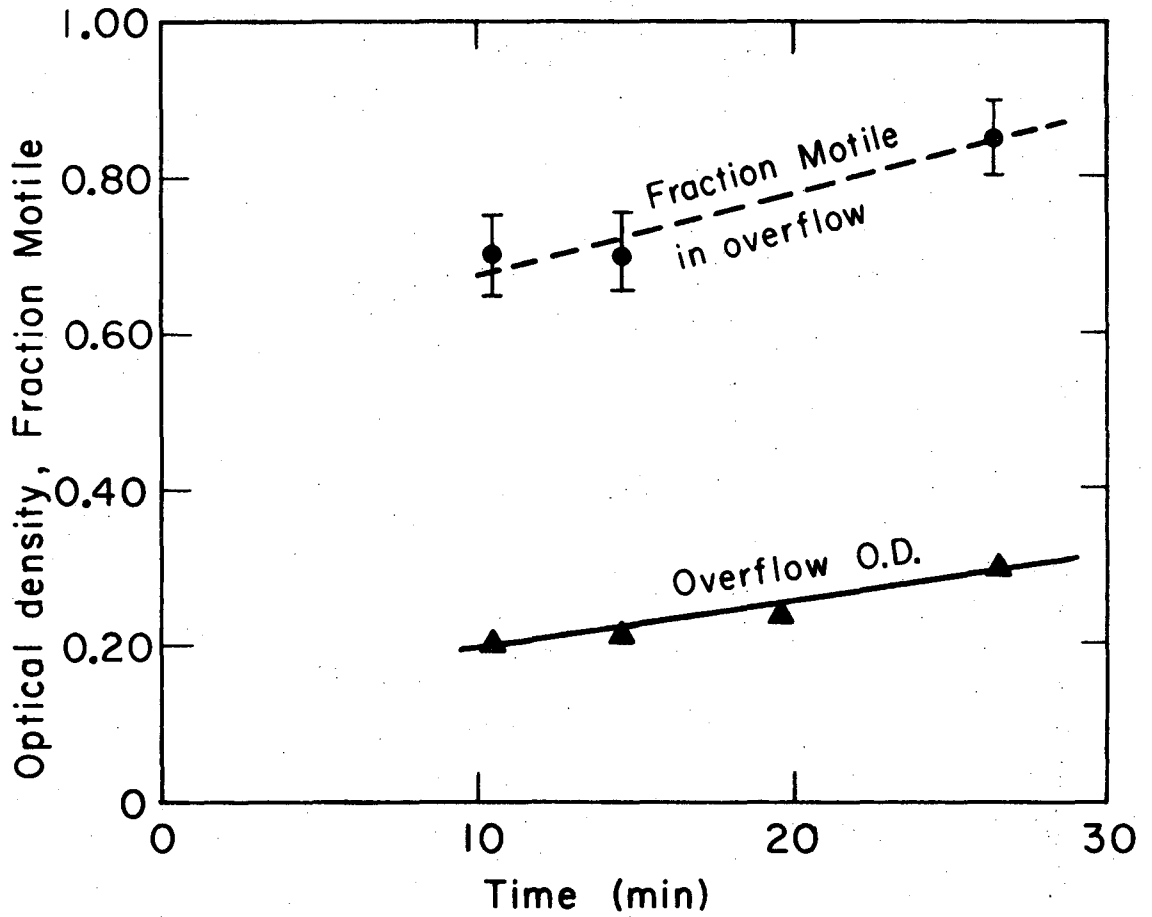

XBL7112-2103

Fig. 17. Phototactic separation run 3 - Light Off,
Feed O.D. = 0.47, overflow rate = 122 ml/min.

flow (i.e. separable, unseparated organisms) versus time. Fig. 15 represents run 1 in which the column was allowed to fill and then run in the dark for 16 minutes before the light was switched on. The fraction motile and total O. D. of the overflow continued to rise slightly in the dark and dropped swiftly when the light was switched on (see arrow at 16 minutes). The sharp drop in O. D. and motility accompanying the light is truly dramatic. This plot alone goes a long way towards demonstrating the feasibility of the device.

Figs. 16 and 17 demonstrate contrasting runs 2 and 3 respectively. Run 2, with a flow rate of 135 ml per minute, was carried out with the light on. Run 3, with a flow rate of 122 ml per minute, was carried out in the dark. The end of each run is considered a steady state and the results are compared in Table 6. 99.9% of the motile organisms were harvested when the light was on and only 38.3% when the light was off. 38.3% of the immotile organisms were also harvested when the light was off and about 42.5% when the light was on.

4. Discussion

A feed containing 85% motile organisms was fed to the separator. In the dark, settling claimed a total of about 38% of both motile and immotile organisms. This result was surprising as we had expected the first organisms to enter the underflow to be mostly non-motile and once the downflow started to have random capture of motile organisms by collision of motile organisms with the relatively swiftly moving downflow zone.

When the light was on (run 2), 91.4% of the organisms were removed from the main stream including 99.9% of the motile organisms and roughly 42.5% of the immotile ones. This tends to indicate that about the same number of immotile organisms found their way into the downflow as in the

previous case but that a perfect separation of motile organisms was achieved. (One might expect a large downflow in the light resulting in more immotiles trapped, but a larger downflow also results in a faster bulk upflow, and these factors, possibly important to other hydrodynamic arguments, may compensate fairly evenly.) The results are presented in Table 6.

There are also other ways of manipulating algae with the aid of light. Algae that swim towards a light source will tend to swim in the opposite direction if the source is too intense and is a danger to their photosynthetic apparatus. Algae appear to be most sensitive to blue light with little or no response to red and near infrared.

5. Conclusions

We concluded that Phototactic Separation is effective for removal of motile *Pandorina* from dilute suspensions. The effectiveness of the Inclined Wall Phototactic Separator has been demonstrated. On the basis of the preliminary experiments, we recommend further investigation of phototactic separational devices with the aim of developing a device for an industrial scale separation.

E. Scale-up of a Phototactic Separator

For the purposes of calculation, we can scale up our experimental separator keeping flow rate per unit cross sectional area constant. The present separator (1/2 in. by 5-1/2 in.) has an 0.0191 ft.² cross section.

Run 2 having a 99.9% effective removal of motile organisms had a flow rate of 51.4 gallons per day (135 ml/min.). A 750,000 gallons per day capacity would require about 28 ft.² of cross sectional area.

The laboratory separator had a length of 2 ft. and a gap in direction of the light source of 1/2 in. An obvious, but unanswered question

TABLE 6. Summary of Phototactic Separation Runs 2 and 3.

<u>FEED</u> (Both Runs)		
Total Optical Density (O. D.)		0.470
Bacteria O. D.		0.039
Pandorina O. D. (85% Motile)		0.431
Motile Pandorina O. D.		0.366
Immotile Pandorina O. D.		0.065
<u>OVERFLOW</u> (At Steady State)		
	Run 2	Run 3
	LIGHT ON	LIGHT OFF
Flowrate (ml/min)	135	122
Bacteria O. D.	0.039	0.039
Pandorina O. D.	0.037	0.266
Motile Pandorina O. D.	0.00055	0.226
Immotile Pandorina O. D.	0.036	0.040
<u>% Organisms Harvested in UNDERFLOW</u>		
Pandorina (Motile and Immotile)	91.4%	38.3%
Motile Pandorina	99.9%	38.3%

is "if the length of the device and the gap width were increased, how would the maximum flow rate for 99.9% removal of motile organisms be effected?" It is possible that by altering the design measurement, we could greatly decrease the 28 ft.² of cross sectional area required for our 750,000 gallons per day plant. The same separational capacity is also supplied by a pair of centrifuges at a total installed cost of \$400,000.

F. Keeping Pandorina Dominant in a Pond

In order to enjoy the special advantages of Pandorina it is necessary to ensure that it is the dominant species in the algal growth pond. The following suggestions and observations may be useful:

1. A small population of Rotifers keep competing chlorella from becoming competitive with Pandorina in an open culture. A mixed Pandorina - Rotifer culture left in an open 5-gallon tank kept its composition for three months.

2. Phototactic procession of the organisms from a pond combined with a large recycle "seeding" stream will help to give responsive "phototactic" organisms a growth advantage.

3. Occasional mixing of the pond would prevent bottom growers from getting up where the light enters. This along with a non-stick bottom surface and fairly uniform flow through the pond should be to the advantage of a motile organism.

4. Pandorina's life cycle is such that the phototactically active young organisms swim to the top and fight to stay on the surface. When they are ready to divide, they sink to the bottom until the young swim free of their parent's old shell. (The active phototactic organisms are the likely ones to leave the pond during harvest because the flow profile of the

pond will not disturb the bottom. They can then be separated and recycled as in suggestion 2 above.) In a vigorous but fairly dense pond, almost all the light will be absorbed by the organisms near or at the surface.

5. It may be possible to breed special algal strains to improve on the ones now available.

VI. ALGAE AS A PROTEIN SOURCE

A. The Direction

From a long range ecological point of view, algal culture can be seen as generating new fixed carbon resources. By comparison, utilization of petroleum for food production is a depletion of a fixed carbon resource. While use of other than carbon (CO_2) fixation methods of food production may seem justified in processing of "waste" materials, policies of resource depletion are of questionable wisdom and longevity.

The two major methods of carbon fixation likely for future use are algal culture and agriculture of higher plants. Comparisons of these two methods often appear to favor algae as a potential protein source. The advantages of algae include high growth rates, continuous utilization of all land area (and thus all available sunlight), and high protein contents. While a variety of technical, economic, and psychological problems remain to be solved, we look forward to a future in which the solutions will be found.

Having chosen *Pandorina morum* as the general organism for our investigation, we became interested in establishing its food potential. However, we did not locate any such information in the literature. As we were not equipped for amino acid analysis, we submitted samples to the U. S. Department of Agriculture Western Regional Research Laboratories for

analysis. Two years later, during the third series of runs of experiment 3 (runs 3-1 to 3-8) (see Chapter 3, section E) we also harvested a batch to establish protein content. This later batch was sent to the McGaw Laboratories Division of the American Hospital Supply Corporation for amino acid analysis.

B. Comments on Pandorina morum Borey Used in Analysis

Details of the standard procedures used to prepare the Pandorina are given in Appendix 1.

The algae labeled "3/18" were grown in the tubular growth tanks and were no longer in their rapid growth phase, but can be considered to be slightly older cells. However, they still maintained about 50% motility which indicates a degree of vitality. Samples sent to the U. S. Department of Agriculture were grown in a flat falling film cooled growth reactor.

The Pandorina were grown with a specific growth rate ($\frac{F}{V} = \frac{25}{2000}/\text{hr.}^{-1}$) and half were harvested as Sample 1. The reactor was refilled and grown to a smaller optical density (but greater dry weight) over a three-day period and then one half was harvested again as Samples 2 and 3.

Sample 1 showed a Carotene level of 114 mgs/lb and a Xanthophil level of 655 mgs/lb. Sample 3 had Carotene and Xanthophil levels of 41 and 279 mgs/lb respectively.

Pigments were lower in the case of Sample 3 because they were reduced on a per cell basis during the early rapid growth period and had not managed to build up to their final concentration when the second harvest took place.

All samples were freeze dried immediately upon harvesting.

The procedure used in the McGaw Laboratory analysis is presented in Appendix E.

C. Discussion of Results of Amino Acid Analysis

The McGaw Laboratory report made the following comments on its findings,

"...We estimate the error in [the hydrolysis] procedure to be less than 5% and the amino acid analysis to be $\pm 3\%$.

"The chromatograms were very "clean", showing few anomalous ninhydrin-positive compounds or decomposition products due to the hydrolysis of the protein.

"The recovery of nitrogen is quite high (89%) in our opinion, indicating that a large quantity of the nitrogenous compounds found in the algae are protein or amino acid in nature.

"...Total nitrogen content (Kjeldahl method) was found to be 6.25% (w/w). The amino acid nitrogen content represents 89% of the total nitrogen found in the algae."

D. Discussion of Results

The results of the amino acid analysis of *Pandorina morum* Borey are presented in Table 7.

1. According to Kohler et al^{15,16}

a) Cysteine and methionine and tryptophan are largely destroyed by hydrochloric acid during the analysis. Tryptophan can be released by alkaline hydrolysis and analysed in a separate analysis. Cysteine and methionine can be converted to stable derivatives by oxidizing them with performic acid ($\text{H}_2\text{O}_2 + \text{HCOOH}$) to their

TABLE 7. Amino Acid Analysis of *Pandorina morum*

Sample	McGaw ¹³ Labs.		U. S. Department of Agriculture ¹²				WHO Standard ¹⁴			
	3/18		1	2	3			Hens Egg	1957 FAO	
Kjeldahl %N	6.25		12.6		9.39		10.14			
<u>Amino Acid</u>	<u>%w/w</u>	<u>%w/wp</u>	<u>%w/w</u>	<u>%w/wp</u>	<u>%w/w</u>	<u>%w/wp</u>	<u>%w/w</u>	<u>%w/wp</u>	<u>%w/wp</u>	<u>%w/wp</u>
Aspartic Acid	3.03	9.63	3.50	8.66	2.75	9.70	2.76	9.54		
Threonine	≤ 1.66	5.28	1.79	4.43	1.48	5.22	1.48	5.12	5.1	2.8
Serine	1.42	4.51	1.54	3.81	1.27	4.48	1.26	4.36		
Proline	≤ 1.83	5.81	1.69	4.18	1.41	4.97	1.41	4.88		
Glutamic Acid	3.60	11.44	4.41	10.91	3.19	11.25	3.15	10.89		
Glycine	2.01	6.39	2.79	6.90	2.09	7.37	2.17	7.50		
Alanine	2.52	8.01	2.76	6.83	2.17	7.65	2.19	7.57		
Valine	2.05	6.51	2.43	6.01	1.93	6.81	1.87	6.47	7.3	4.2
Methionine	0.40	1.27	0.70	1.73	0.36	1.27	0.48	1.66	3.1	2.2
Isoleucine	1.44	4.57	1.66	4.11	1.28	4.52	1.30	4.50	6.6	4.2
Leucine	3.06	9.72	3.41	8.44	2.66	9.38	2.71	9.37	8.8	4.8
Tyrosine	0.93	2.95	1.44	3.56	1.03	3.63	1.07	3.70	4.2	2.8
Phenylalanine	1.89	6.00	2.15	5.32	1.68	5.93	1.70	5.88	5.8	2.8
Ammonia	0.59	1.87	--	--	--	--	--	--		
Lysine	2.39	7.59	2.52	6.24	1.87	6.60	1.93	6.67	6.4	4.2
Histidine	0.66	2.10	0.88	2.18	0.58	2.05	0.62	2.14		
Arginine	2.00	6.35	6.58	16.28	2.49	8.78	2.62	9.06		
1/2 Cys	--	--	0.38	0.94	0.20	0.71	0.22	0.761		
TOTAL	<u>31.48</u>		<u>40.41</u>		<u>28.35</u>		<u>28.92</u>			

respective stable derivatives, cysteic acid and methionine sulfone. Therefore, the true values of these amino acids may be considerably higher than indicated in Table 7.

b) Threonine and serine are destroyed to a moderate degree by acid hydrolysis but correction factors based on kinetic studies are available. (Threonine value \times 1.036 = corrected value; serine value \times 1.082 = corrected value.)

c) Valine and isoleucine are released too slowly during hydrolysis and correction factors based on kinetics are available. (Valine value \times 1.081 = corrected value; isoleucine value \times 1.078 = corrected value.)

2. In addition to amino acid composition results, the results of animal feeding tests would also be valuable. These tests would indicate the available amino acids which may be less than the total amount of amino acids present. However, we could not run these tests because of lack of material.

3. The Kjeldahl results for the McGaw Laboratories samples indicating 89% of the nitrogen in the amino acid form, indicates a low nucleic acid content for the Pandorina. This is a very favorable sign in that the high level of nucleic acids in yeast decreases the attractiveness of yeast as a food source.

4. The high Kjeldahl values for the U. S. D. A. analyzed samples are due to the fact that the algae used for those cases were not thoroughly rinsed free of the nitrogen rich media before freeze drying. The McGaw samples were thoroughly rinsed before freeze drying.

5. The values obtained during these tests are interesting enough to warrant further investigation of Pandorina as a food source.

VII. SUMMARY OF CONCLUSIONS

This chapter contains a brief summary of the conclusions of this thesis. We investigated the use of algae as ion exchange beads. We experimentally determined the ion exchange characteristics of *Pandorina morum*. We carried out an economic analysis of a plant for treatment of low level radioactive waste, utilizing algae as ion exchange beads. We found the algae process to be more costly than a conventional ion exchange process. We concluded that the primary expense of the algal process came in the separation of algae from dilute suspensions. We investigated phototaxis as a possible mechanism for separating algae from solution at a reduced cost. We presented amino acid analysis of *Pandorina* to determine the food content of that organism. The conclusions of the various chapters of this thesis are presented in the following paragraphs.

In Chapter III we examined algae as ion exchange beads. The first experiment demonstrated that the kinetics of absorption is sufficiently fast so that equilibrium is obtained in less than two minutes. The second experiment indicated that the mechanism for cation uptake is probably ion exchange. In Experiment 3 we found that a vigorously growing culture of *Pandorina* will have 1.4 milliequivalents of cation exchange sites per gram dry weight of algae at pH 5.5 and about 0.7 milliequivalents below pH 4.0. Older cultures, having exhausted their media and become less active, tend to have fewer ion exchange sites per gram dry weight algae. Selectivity coefficients for *Pandorina morum* in a Ca^{++} , Sr^{++} , Mg^{++} solution were found to be $K_{\text{Ca}}^{\text{Sr}} = 1.2$, $K_{\text{Mg}}^{\text{Ca}} = 1.8$, $K_{\text{Mg}}^{\text{Sr}} = 2.2$. Therefore the hierarchy of preferences of the absorption sites are $\text{Sr}^{++} > \text{Ca}^{++} > \text{Mg}^{++}$. The data was tested in a staged

experiment and the experimental results were successfully predicted.

Chapter IV contains a comparison of plant designs for treating 1000 gallons of low level radioactive waste every two minutes. The process employing algae as ion exchange beads costs 3 times as much as a conventional ion exchange process. A major reason for the poor economics of the algal process was the high cost of handling algae with centrifuges. We suspect that the algal process will become more promising with cheaper separation techniques.

In Chapter V we explained the development of phototactic separational equipment, which utilizes the tendency of *Pandorina* to swim towards a light, as a means of separating these organisms from a dilute suspension. We lack sufficient information to predict the cost and operating characteristics of industrial scale Phototactic Separators and therefore did not reevaluate the algal clean up process in terms of utilizing Phototactic Separators instead of centrifuges.

The development of a cheap means of separation would not only increase the feasibility of the algal process but would also lower the cost of producing algae as food. In Chapter VI *Pandorina morum* were analyzed for their protein and amino acid contents. 28.3% - 40.4% of the dry weight of the algae was recovered as amino acids. Most of the Nitrogen content of the algae was found to be in the amino acid form. We concluded that further investigation of *Pandorina* as a food source is warranted.

We recommend the further examination of the properties of *Pandorina morum* and of phototactic separational techniques.

ACKNOWLEDGEMENTS

We are indebted to Professor Ted Vermeulen for his years of concern and advice, and to Professor William Oswald, an invaluable resource of information for large scale algal growth systems.

We wish to thank Peter Clark and members of the Western Regional Research Laboratory for the initial *Pandorina* amino acid analysis.

We are also indebted to Norm Yoshimura, Fred Deindoerfer and Jack Olshansky for the final *Pandorina* amino acid analysis.

We thank the A. E. C. and the staff of the Berkeley Lawrence Radiation Labs for supporting my thesis.

Joe Dabies was invaluable to the successful design and completion of the Phototactic Separation experiment and also for his green thumb.

We are grateful to our close friends for their succors: Bruce Sprague, Moira Ralls, Danessa Timmer, and Michael Cahn. We must also thank Steve's parents who continued to believe it was possible.

APPENDIX A

Support Equipment and Standard Procedures

1. A Preparation of the Organisms

a. Cultures Used

The principle organism used in these experiments was *Pandorina morum* Bory #876-WILBOIS MAS-5-2. It was obtained from:

The Culture Collection of Algae
Department of Botany
Indiana University
Bloomington, Indiana
Phone - 812 - 337-5353

Other organisms examined in these experiments were: #18, 788, 870, 872, 878, 880, and 881 of the Wilbor's strain (Indiana Culture collection) and *Chlorella pyrenoidosa* Emerson, *Volvox*, *Chlamydomonas*, and *Euglena* from the University of California Botony Department.

b. Start-up Process

The cultures were obtained from Indiana on agar slants and transferred to 15 ml of dilute media (media A) in sterile glass 40 ml Screwtop containers with inverted 20 ml pyrex beakers acting as lids.

It seems that in order to leave the resting stage (adopted by the organism while on the agar in transport) the organism must first alter its environment supposedly including the excretion of some chemical. Therefore, cultures have a better chance of start-up when surrounded by a limited amount of media.

When growth became apparent in these standing liquid tubes, the organisms were transferred to the second stage of the scale-up.

The second stage scale-up consisted of sealed, 200 ml jars containing 100 ml of media aerated with filter 4% CO₂ in air through coarse

fitted glass spargers. Upon maturation of the culture, the entire 100 ml could then be transferred aseptically to one of the large growth reactors (tanks).

c. The Tubular Reactors

These growth tanks are test tube shape, rounded at the bottom, 6 in. in diameter and 24 in. high. Through the neoprene stopper on top we have the following:

- 1) A line to a coarse fritted glass sparger for a 4% air-CO₂ mixture.
- 2) A liquid media line.
- 3) A one inch diameter forced water coolant tube extending to the bottom of the reactor, bending in a U, and then running through the top of the tank.
- 4) A thermometer port.
- 5) An inoculum port.
- 6) An air exit line attached to a long tube with a downward run of about six feet to provide against bacterial back-up into the tank.

The walls were equipped with sample ports at 6 in. and 22 in. from the tank bottom.

A magnetic stirrer bar rotated on the tank bottom.

When first inoculated, the reactors were only partially filled, but later they were run at capacity.

d. The Flat Falling Film Growth Reactors

These reactors were constructed by making a sandwich of two sheets of parallel plate glass with one cm thick "spacers" separating the two

sheets. The spacers were organized with a 60° incline near the bottom and attached with silicone rubber glue to provide a water tight seal.

The reactor had the following:

- 1) Stirring was provided by a magnetic stirrer and by the air-CO₂ mixture which entered below the stirrer.
- 2) 60° slanted walls near the bottom prevented settling of the algae from becoming a problem.
- 3) Liquid media entered the bottom through the same line as the air.
- 4) An air-liquid exit line left via the top corner.
- 5) The reactor was tilted a few degrees to provide better air removal from the top surface.
- 6) A mercury pressure gauge at the very top of the reactor was connected by electrical relay to an emergency exit (opened by solenoid) 2 in. down from the top. In case the power failed, the mercury would have been expelled from the gauge and the gauge itself would become an exit line.
- 7) A liquid film from a constant temperature bath ran down the outside of one face of the reactor. This provided adequate cooling with any lighting loss.
- 8) Two liquid media feed systems were available. The first was a two timer, two solenoid device which filled a constant volume tank for a designated period of time and then fed the contents into the reactor during a second designated period of time. Since the doubling time of the algae was slow, this same batch-feed techniques could be assumed to be continuous. The second feed system was based on an optical density mea-

suring device which turned a finger pump on for a fixed period of time each time it found the algae density to be too high. This sophisticated device was developed for the Biodynamics group on the Berkeley campus.

In either feed system, the liquid originated in 5 gallon, sterile media bottles.

- 9) Light was provided by two adjustable intensity, parallel banks of fluorescent lights described elsewhere in this thesis.
- 10) Density of the algae could be roughly followed with a light meter.

e. Lights

The equipment rack had two parallel banks of lights. Each bank consisted of 12 vertical G. E. Cool White (T12) light bulbs (4 ft. high), standing with their centers 2 in. apart. This provided two uniform light sources 4 ft. high by 25 in. wide, of variable intensity, and with a visible light spectrum similar to daylight.

Light became the "limiting nutrient" as soon as the cultures became fairly dense. Therefore, good lighting was critical for supply of vigorous cultures for our experiments.

f. Constant Temperature Bath

The bath consisted of a 2'x2'x2' insulated tank with the following arrangements:

- 1) A tap water inlet for filling and as coolant stream.
- 2) A water overflow.
- 3) A drainage port.
- 4) A circulating pump to provide uniform mixing.

- 5) A Beckman thermometer connected to a relay.
- 6) A bank of knife blade heaters activated by the relay.
- 7) Pumps to deliver the tank fluid to various place. One application was to provide a falling film for thermal control of the flat reactors.
- 8) CuSO_4 was occasionally added to prevent algae from building up in the bath.

g. The Centrifuge

Algae removed from the reactors were centrifuged in a Sorval super-speed (RC-2) centrifuge. Two minutes at 1000 g's was sufficient to allow decanting of the supernatant from Pandorina cultures, but closer to 10 minutes at 10,000 g's were used to decant from Chlorella cultures.

2. pH Measurement

pH's were measured with a Beckman Century SS pH meter. The instrument has expand scale capacity around any interger pH. It also has thermal correction compensation. A combination electrode, capable of monitoring the pH of very small volumes of liquid reproducably was employed for this study.

3. Drying the Algae

Dry weights were taken by drying the algae in tared glass or porcelain containers in a 90°C oven. Algae were also dried in a Virtis Freeze Dryer.

The algae that were set aside for protein analysis were always freeze-dried first and then placed in sealed nalgene containers and held in the freezer until they were ready to be sent for analysis.

4. Weights

Materials were weighed on a Volland & Sons Chainomatic balance.

During the last six months, a Mettler automatic balance was used.

5. Analysis of the Algae for Cation Content

a. Preparation of Glassware and Crucibles

- 1) Containers were soap washed to remove gases, etc.
- 2) Containers were distilled water rinsed.
- 3) Containers were 3N HCL washed to remove any cation deposits.
- 4) Containers were distilled water washed to remove HCL.
- 5) Containers were aluminum foil wrapped and/or stored in closed containers to prevent dust contamination.

In very early experiments, contamination of samples made AA analysis unreliable.

b. Preparation of Samples

Samples were ashed in acid washed porcelain crucibles equipped with lids. First they were slowly charred until smoke was no longer being emitted by the samples and then the cinder was reduced to ash by heating the crucibles to a red glow with air-gas "blast burners". After the samples cooled, 25 ml of 2N HCL was added to the crucible. Forty-eight hours later, the liquid from the crucible was transferred to a screw-top nalgene bottle to be held for A.A. analysis. Just prior to running the samples 0.5 ml aliquots were further diluted at least 10 to 1 by 0.1% $\text{La}(\text{NO}_3)_3$ with a Labindustries "automatic diluter" and placed directly in 5 ml Beckman AA feed cups. The purpose of the $\text{La}(\text{NO}_3)_3$ solution was to have La replace Ca in CaPO_4 because CaPO_4 does not dissociate sufficiently to allow a true Ca^{++} reading in the Atomic Absorption flame.

c. Atomic Absorption Analysis

The system used was a Beckman Model 979 Atomic Absorption System which included a Beckman DB-G Spectrophotometer and an air-acetylene Laminer Flow Burner, a "Sr" lamp and a "Ca-Mg-Al" lamp. The Sr lamp was run at 15 milliamperes (25 m.a. maximum) and the Ca-Mg-Al lamp was run at 10 milliamperes (20 m.a. maximum). The flame was run with 25 psi air and 4.5 psi acetylene. A Beckman ten inch chart recorder running at 0.5 in. per minute was used to record the results. The spectral lines used were Ca - 4227 Å, Mg - 2852 Å, and Sr - 4607 Å.

Beckman standard solutions of Ca, Mg, and Sr served as standards for comparison with our unknowns.

The following procedure was used during analysis:

- 1) Samples, standards and distilled water were prepared in sample feed cups.
- 2) Distilled water was run through the asperator continuously from a larger container. The recorder chart was run at low speed.
- 3) Materials were fed through the asperator in 15 to 20 second periods with quick substitutions of one container for another. Even patterns of operation and minimum lags with liquid entering the flame were necessary for reproducible results.
- 4) At first, samples of distilled water and the standard were alternated as feed to the device until the instrument seemed reproducible.
- 5) Then we ran the samples with the following alternation:
 - 1) Distilled water
 - 2) Standard
 - 3) Sample
 - 4) Standard
 - 5) Distilled water

For very dilute samples the procedure was:

- 1) Distilled water
- 2) Standard
- 3) Distilled water
- 4) Sample
- 5) Distilled water
- 6) Standard
- 7) Distilled water
- 8) Sample (new or same)

Samples were usually run three times to insure the validity of the readings. The instrument often had clogging problems and electrical noise was obvious on the chart.

Hot mode was 10 times more sensitive than cold mode, but was more prone to electrical noise problems.

- 6) Some samples, too concentrated for the device, had to be diluted by 10, 100, or 1000 with the $\text{La}(\text{NO}_3)_3$ via the automatic dilutor.

Blanks were run on the $\text{La}(\text{NO}_3)_3$ solution and the 2N HCL elution solution.

6. Media

a. Formula A (start-up medium)

Into one 20 liter Pyrex bottle was placed:

- | | |
|---|-------------|
| a) Distilled water | 20.0 liters |
| b) $\text{Ca}(\text{NO}_3)_2 \cdot 4\text{H}_2\text{O}$ | 10.0 grams |
| c) $\text{MgSO}_4 \cdot 7\text{H}_2\text{O}$ | 1.7 grams |
| d) $\text{K}_2\text{HPO}_4 \cdot 3\text{H}_2\text{O}$ | 2.0 grams |
| e) $\text{NaH}_2\text{PO}_4 \cdot \text{H}_2\text{O}$ | 0.4 grams |
| f) Trace Beig (with Fe) | 40.0 ml. |
| g) B Vitamins | |

The above solution was steam sterilized for 3 hours at 15 psi.

It was employed as a dilute base for the various algal cultures and for

starting the Pandorina from the agar slants.

b. Formula B (Pandorina medium)

Three bottles were autocleaved at 15 psi for three hours.

Into one 20 liter Pyrex bottle was placed:

- a) Distilled water 18.0 liters
- b) CaCl_2 (dehydrate) 2.0 grams
- c) $\text{MgSO}_4 \cdot 7\text{H}_2\text{O}$ 10.0 grams
- d) Beig Trace 80.0 ml

Into one 1 liter Pyrex bottle was placed:

- a) $\text{KH}_2\text{PO}_4 \cdot 3\text{H}_2\text{O}$ 10.0 grams
- b) Distilled water 1.0 liter

Into one 1 liter Pyrex bottle was placed:

- a) Urea 20.0 grams
- b) Distilled water 1.0 liter

When the three bottles cooled to room temperature, their contents were mixed with efforts made to maintain sterility. Mixing when hot led to precipitation.

c. Formula C (Pandorina medium)

Two bottles were autocleaved at 15 psi for 3 hours.

Into one 20 liter Pyrex bottle was placed:

- a) Distilled water 19.0 liters
- b) CaCl_2 (dihydrate) 1.5 grams
- c) $\text{MgSO}_4 \cdot 7\text{H}_2\text{O}$ 5.0 grams
- d) KNO_3 32.0 grams
- e) Beig Trace 40.0 ml

Into one 1 liter Pyrex bottle was placed:

- a) $\text{KH}_2\text{PO}_4 \cdot 3 \text{H}_2\text{O}$ 5.0 grams
- b) Distilled water 1.0 liter

After the solutions cooled to room temperature, the contents were carefully mixed to maintain sterility.

d. Formula D (Chlorella medium)

Into one 20 liter Pyrex bottle was placed:

- a) Distilled water 20.0 liters
- b) $\text{MgSO}_4 \cdot 7\text{H}_2\text{O}$ 50.0 grams
- c) KNO_3 100.0 grams
- d) $\text{KH}_2\text{PO}_4 \cdot 3\text{H}_2\text{O}$ 25.0 grams
- e) Trace solution 100.0 ml

The above solution consists of:

- a) Ca (CaCl_2) 30.0 ppm
- b) B (H_3BO_3) 20.0 ppm
- c) Fe ($\text{FeSO}_4 \cdot 7\text{H}_2\text{O}$) 10.6 ppm
- d) Zn ($\text{ZnSO}_4 \cdot 7\text{H}_2\text{O}$) 20.0 ppm
- e) Mn ($\text{MnCl}_2 \cdot 4\text{H}_2\text{O}$) 4.0 ppm
- f) Mo (MoO_2) 4.0 ppm
- g) Cu ($\text{CuSO}_4 \cdot 5\text{H}_2\text{O}$) 4.0 ppm
- h) Co ($\text{Co}(\text{NO}_3)_2 \cdot 6\text{H}_2\text{O}$) 1.0 ppm
- i) V (V_2O_5 in HCL) 2.0 ppm
- j) EDTA 0.5 grams per liter

The pH was adjusted to 6.5 with KOH

7. Standardization of Dry Weight Determination

Pandorina were dried in tared crucibles in a 90°C oven for 24 hours, weighed, returned to the oven for a 2nd 24 hour period, and then reweighed. The results obtained are listed in Table 8.

Dry weight is about 10% wet weight. The average loss during the 2nd 24 hour period is less than 1% and therefore this drying technique appears to give a reproducible answer.

TABLE 8. Dry Weights via the 90° Drying Oven

Crucible #	24 hr. Dry Wt.	48 hr. Dry Wt.		% Change
33	.1521	.1511	.0010	0.7
32	.1465	.1459	.0006	0.4
31	.1525	.1511	.0014	1.0
30	.1509	.1486	.0025	1.6
29	.1507	.1493	.0014	1.0

8. Standardization of the Ashing Procedure

The algal cells were removed from a reactor, concentrated via centrifugation, and then washed with a solution of 10 ppm Ca^{++} , 10 ppm Mg^{++} in five consecutive stages. The algae were centrifuged after each wash solution addition and the supernatant discarded. The algae were then distilled water washed and the supernatant discarded. Finally the algae were suspended in distilled water, distributed into ten tared crucibles, freeze-dried and weighed.

Crucibles 49, 59, and 60 were eluted with 1 N HCL for 48 hours. Crucibles 56, 57, and 58 were eluted with concentrated HCL for 48 hours.

Crucibles 32 and 34 were ashed over blast burners and then eluted with 2 N HCL for 24 hours.

Crucibles 51, 52, and 53 were transferred to Kjeldahl flasks and digested with a Periodic acid solution over low heat.

The solutions were analyzed for Mg^{++} on the Atomic Absorption Spectropholometer. The results obtained are listed in Table 9.

Since the ashing showed the least loss and interference problems, it was chosen as the standard analytical procedure.

TABLE 9. Methods of Sample Digestion

Method	A. A. Readings	(meq/gms dry wt. Algae)	
1 N HCL Digestion	.43	.44	.428
Conc. HCL Digestion	.40	.422	.393
Ashing + 2 N HCL Elution	.479	.490	
Periodic Acid Digestion	.499	.489	.481

APPENDIX B

Computer Program for Experiment 4

STEQE predicts the results of Experiment 4 (Data Test) which is presented in Chapter III. The Program begins by assuming a value for the total number of cation exchange sites (T) in milliequivalents per gram dry weight algae and a value for the selectivity coefficient (D), K_{Ca}^{Sr} the units of which are defined in equation 1 of this thesis. Since the ratio of supernatant to residue of each operation was known, the prediction of Ca^{++} and Sr^{++} levels in the various supernatants was calculable.

We consider series of 3 "stages" and 10 consecutive transfer "steps" as described in Chapter III, Section F. Material balances determine the total Ca^{++} in each stage in terms of the Ca^{++} that remain in the stage from the previous stop both in the algal and the liquid fraction of the centrifugate, plus the Ca^{++} in the supernatant from the previous step of the preceding stage.

Therefore, if $BM(I,J)$ is equal to the total Ca in the I^{th} stage after J steps:

$$(4) \quad BM(I,J) = V^{*} Ca(I,J-1) + Ca'(I, J-1) + Ca(I-1, J-1) \text{ where}$$

V = volume fraction of liquid which remain with the algal residue

Ca = Ca in the liquid

Ca' = Ca absorbed on the algae

A set of four equations determine the equilibrium in each stage:

$$(5) \quad \text{total Ca} = Ca|_{\text{solution}} + Ca|_{\text{algae}}$$

$$(6) \quad \text{total Sr} = Sr|_{\text{solution}} + Sr|_{\text{algae}}$$

$$(7) \quad \text{total cation sites on algae } T = Ca \text{ on algae} + Sr \text{ on algae} \approx 1.4$$

$$(8) \quad D = K_{Sr}^{Ca} = 1.2 = \frac{Ca|_{\text{algae}}/Ca|_{\text{solution}}}{Sr|_{\text{algae}}/Sr|_{\text{solution}}}$$

The above equations condense to:

$$(9) \quad D = \frac{T-Sr|_{\text{algae}}/BM-(T-Sr|_{\text{algae}})}{Sr|_{\text{algae}}/(BP-Sr|_{\text{algae}})}$$

Which becomes a quadratic equation with Sr^{++} algae as the only unknown. The straightforward solution equations 4 and 9 determine the cation distribution in each stage. We solve each step one stage at a time for the values of Sr|algae , Ca|algae , Sr|solution , and Ca|solution .

STEQE,7,40,50000.468001,MILLER
*USERPR
RUNF(S)
LGO.
7

```
PROGRAM STEQE (INPUT,OUTPUT)
DIMENSION SRA(3,10)
DIMENSION SRL(3,10)
DIMENSION CAL(3,10)
DIMENSION CAA(3,10)
SRLI=0.0100
SRLI=0.0090
SRLI=0.0074
SRLI=0.00760
SRLI=0.0075
SRLI=0.00775
D=1.1
D=1.2
A= 0.15
T=1.30
T=1.25
T=1.35
T=1.45
T=1.42
T=1.415
T=1.40
T=1.44
CAAS=T
DO 300 J = 1,10,1
DO 200 I = 1,3,1
IF (J-1) 50,50,70
50 BM=A*CAAS
BP=30.0*SRLI
GO TO 140
70 IF (I-1) 100,100,120
100 BP=0.9*SRL(I,J-1)+30.0*SRLI+A*SRA(I,J-1)
101 BM=0.9*CAL(I,J-1)+A*CAA(I,J-1)
GO TO 140
120 BP=0.9*SRL(I,J-1)+30.0*SRL(I-1,J-1)+A*SRA(I,J-1)
121 BM=0.9*CAL(I,J-1)+30.0*CAL(I-1,J-1)+A*CAA(I,J-1)
140 RA=A*(D-1.0)
RB=-(A*T*(D-1.0)+D*BP+BM)
RC=D*T*BP
PRINT 9,I,J
9 FORMAT (*I = *,I2,* J = *,I2)
PRINT 10,BM,BP
10 FORMAT (*BM=*,F10.5,*BP=*,F10.5)
X=(-RB+SQRT (RB**2 -4.0*RA*RC))/(2.0*RA)
PRINT 11,X
11 FORMAT (*X=*,F10.5)
IF (X) 160,150,150
150 IF (T-X) 160,175,175
160 X=(-RB-SQRT (RB**2 -4.0*RA*RC))/(2.0*RA)
PRINT 12,X
12 FORMAT (*X=*,F10.5)
IF (X) 480,170,170
```

```
170 IF (T-X) 480,175,175
175 SRA(I,J)=X
    SRL(I,J)=(BP-A*SRA(I,J))/30.9
    CAA(I,J)=T-SRA(I,J)
    CAL(I,J)=(BM-A*(T-SRA(I,J)))/30.9
    PRINT 2,SRA(I,J)
    PRINT 3,SRL(I,J)
    PRINT 4,CAA(I,J)
    PRINT 5,CAL(I,J)
200 CONTINUE
300 CONTINUE
    PRINT 325,SRLI,D,T
325 FORMAT (1H1,*SRLI = *,F10.8,*   D = *,F10.8,*   T = *,F10.8//)
    DO 450 I = 1,3,1
    DO 400 J = 1,10,1
    PRINT 350,J,I,SRA(I,J),SRL(I,J),CAA(I,J),CAL(I,J)
350 FORMAT (*J = *,I2,*   I = *,I2,*   SRA(I,J) = *,F10.8,
    +*   SRL(I,J) = *,F10.8,*   CAA(I,J) = *,F10.8,*   CAL(I,J) = *,
    +F10.8)
400 CONTINUE
450 CONTINUE
C   STAGED EQUILIBRIUM EXPERIMENT
C   CAA(I,J)=T-SRA(I,J)
C   CAL(I,J) IS C MEQ/ML IN LIQUID STAGEI,AFTER THE JTH TRANSFER
C   SRL(I,J)IS MEQ SR / ML SOLKTIONI IN ITH STAGE AFTER J TRANSFERS
C   SRA(I,J) ISMEQ SR IN ITH STAGE AFTER J TRANSFERS

C   T IS TOTAL MEQ SITES PER GM DRY WT ALGAE
C   D = K(SR/CA)  ((MEQ/GM)/(MEQ/ML))/((MEQ/GM)/(MEQ/ML))
C   CAAS= INITIAL CA ON ALGAE (MEQ/GM)
C   SRLI= SR IN WASH SOLUTION (MEQ/ML)
C   A'GMS DRY WT ALGAE / TUBE
C   LHO=ML LIQUID HELD OVER = 0.9 ML
C   LT= ML LIQUID TRANSFEREDFROM PREVIOUSSTAGE = 30.0ML
    RETURN
480 PRINT 500
    RETURN
500 FORMAT(1X,*SRA(I,J) IS OUT OF BOUNDS*)
    2 FORMAT(10(1X,3F10.8//))
    3 FORMAT(10(1X,3F10.8//))
    4 FORMAT(10(1X,3F10.8//))
    5 FORMAT(10(1X,3F10.8//))
    END
```

APPENDIX C

Computer Program for Process Cost Analysis

A. Computer Evaluation of the Algal Clean-up Process

The optimization of the algal Sr clean-up process was carried out with the aid of a computer program. This Appendix contains a description of the approach taken. We refer the reader to Fig. 11 of the text which presents two "paths" or process variations.

- 1) Path one has algae leaving a growth pond and entering a preseparator stage. From the preseparator, A(JJJ) pounds of algal concentrate are fed to a "contactor" section. In the contactor section, the algae are moved countercurrent to a contaminated "low level" Radioactive Waste Stream (WL) in a series of "N" contactor stages (A(JJJ) pounds of algae versus 1000 gallons of waste liquid). The Sr rich algae are then dried and disposed of.
- 2) Path two outlined in Fig. 11 contains a recycle of algae to the pond. The algae leave the pond, pass through a preseparator and a contacting section, and then a small bleed stream is removed and sent to the dryer. The bulk of the algae stream, rich in radioactive Sr, enters a stripping section in which it is moved in stages countercurrent to the movement of a CaCl_2 salt solution (SL(J)). The algae leave the stripping section poor in Sr^{++} and in a Ca^{++} rich solution and then enter a "wash" section. Here, the algae move counter-current (in stages) to a Water Stream (WW) which dilutes the Ca^{++} from their interstices. Finally, the algae, low in Sr^{++} and with little Ca^{++} remaining in their accompanying solution are returned to the growth pond.

The letters S, SS, and SSS are inserted in the program to represent the fraction of the algae in each stage which move

in the opposite direction from the bulk algal flow (slip factor). These slip factors, along with the fraction "bled" determine the amount of algae exiting from and therefore used by the process per thousand gallons of low level waste. Fig. 18 is a block diagram of the computer approach to optimization of the process.

- 3) The optimization of path one consists of computing, for a variety of different algal inputs, the number of stages needed to reduce the Sr^{++} released to the environment by the requisite amount and then minimizing the total cost of algae and stages per unit of waste treated.

The second path is cost optimized in the following way:

- a. Guess the Sr^{++} level in the algal pond (C ZERO).
- b. Guess the amount of algae withdrawn from the pond A(JJJ) (JJJ=1) per thousand gallons of low level waste.
- c. Compute the number of stages "N" needed to meet the clean-up criterion.
- d. Cost optimise the number of stages "M" versus the amount of salt (SL(J)) used to strip Sr from the algae.
- e. Compute the number of stages and cost of washing the Ca^{++} salt from the algae.
- f. Cost optimize the process of a given A(JJJ) input.
- g. Increase A(JJJ) and reoptimize (looking for a best value of A(JJJ)).
- h. Check to see if initial guess on Sr in pond was valid.

Since drying or disposal cost and algal production costs will all tend to be per pound of algae used up in the process,

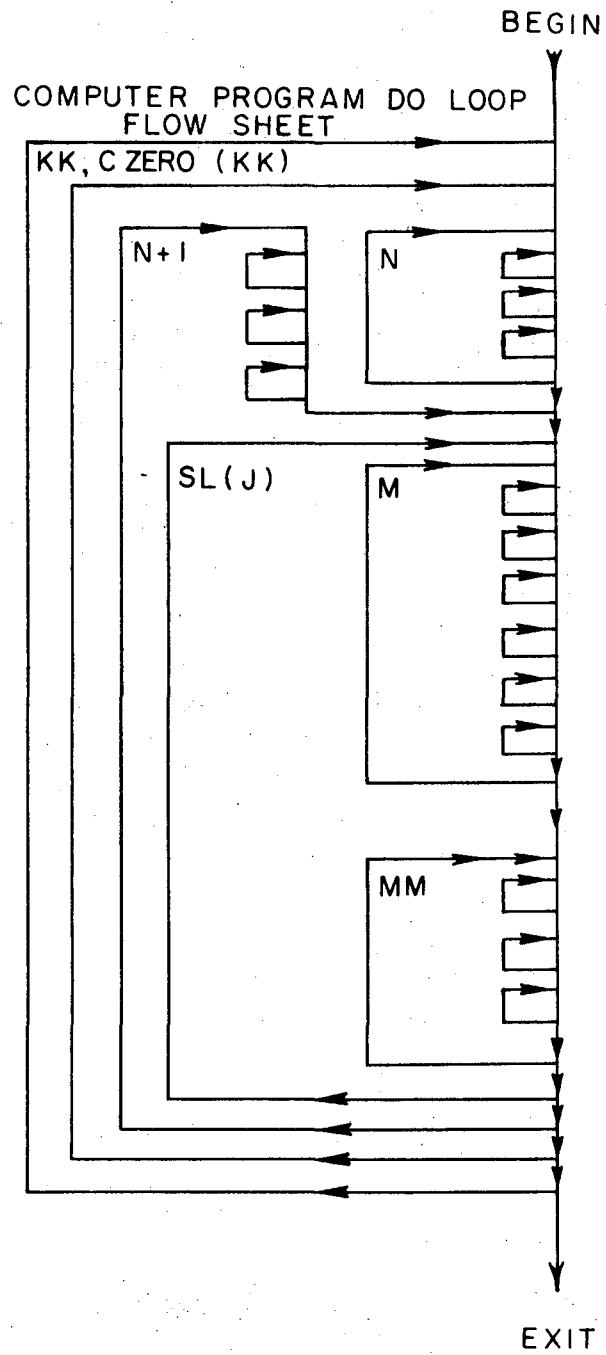

XBL7112 - 2100

Fig. 18. Block diagram of computer Do Loops.

we can simplify our program by using one number to represent the cost of algae per thousand gallons of low level waste.

Results of our cost analysis are given in Table 5.

B. Further Explanation of Computer Mathematics

The approach used to solve this problem can be demonstrated by examining the method by which N is determined.

- 1) We assume a value of A(JJJ) entering the 1st of a series of stages where N is an unknown integer.
- 2) When the slip factor "S" is not zero, the amount of algae entering and leaving each stage will vary with the size of N. Therefore, in order to determine N we start by guessing a (small) value of N in order to calculate the amount of algae entering and leaving each stage. We then use this algae distribution to calculate whether or not the assumed value of N is large enough to meet the S_r^{++} removal boundary conditions of the process.
- 3) If N is not large enough we increase its value by one and recalculate.
- 4) The calculation of algae entering and leaving each stage is carried out by a series of interconnected material balances around each stage.

The I^{th} stage algae material balance is:

$$(10) \quad \text{Algae} \Big|_{\text{From } I-1} = \text{Algae} \Big|_{\text{leaving } I} + \text{Algae} \Big|_{\text{leaving } I}^{\text{ENTRAINED}} - \text{Algae} \Big|_{\text{From } I+1}^{\text{ENTRAINED}}$$

- 5) The boundary conditions are at both ends of the contactor section.
 - a. Boundary condition 1 is that no algae enter the Nth stage in

the LLW stream (i.e., from fictitious stage N+1).

- b. Boundary condition 2 is obtained from the value of A(JJJ) assumed (i.e., algae entering the 1st stage from the pond).
- c. To facilitate the calculation we need two boundary conditions at the same end of the staged process. This can be arranged by substituting for the 2nd boundary conditions the following:
 - 1. Assume a unit value for algae leaving the Nth stage in the algal stream. (B.C. 2')
 - 2. Calculate via the series of "linear" material balance equations the value of algae entering and leaving each stage from the Nth stage down to the 1st stage.
 - 3. Compare the calculated value of algae entering the 1st stage from the pond with the assumed value of A(JJJ) (B.C. 2)
 - 4. Normalize all calculated algal flow values by multiplying them by the ratio of $A(JJJ)_{\text{Assumed (B.C.2)}}$ / -

$$A(JJJ)_{\text{Calculated (B.C. 2')}}$$

[This operation is permissible due to the linearity of the equations involved]

- 6) Having determined the algal flow distribution for the assumed values of A(JJJ) and N we precede to evaluate whether N is sufficiently large, i.e., whether N stages are sufficient to deduce Sr level in the LLW by a factor of > 1000.

- a. Material balance on the Ith stage:

$$(11) \quad \text{Total Sr} \left| \begin{array}{l} \text{In} \\ \text{LLW} \\ \text{From I+1} \end{array} \right. = \text{Total Sr} \left| \begin{array}{l} \text{On} \\ \text{Algae} \\ \text{Leaving I} \end{array} \right. + \text{Total Sr} \left| \begin{array}{l} \text{In} \\ \text{LLW} \\ \text{Leaving I} \end{array} \right. -$$
$$\text{Total Sr} \left| \begin{array}{l} \text{On} \\ \text{Algae} \\ \text{From I-1} \end{array} \right.$$

- b. The equilibrium distribution in each stage is determined by the equation:

$$(12) \quad DK1 = K^{Sr} = K_{Ca}^{Sr} * K^{Ca} = \frac{\text{Sr on Algae meq/gm dry wt (leaving I)}}{\text{Sr in liquid meq/ml (leaving I)}}$$

$$(13) \quad K^{Sr} = 1.2 * \frac{\sqrt{V}(\text{total sites})}{\text{Ca in liquid}} = 1.2 * \frac{0.14}{.000002}$$

- c. Boundary condition 1 is the Sr^{++} entering with algae from the pond (zero in Single Pass Process, CZERO assumed and then tested for in the case of algal recycle).
- d. Boundary condition 2 is that the Sr content of the LLW stream leaving the 1st stage be reduced by a factor of > 1000 from the level in the LLW stream entering the Nth stage. To facilitate calculation we express B.C. 2 as Sr^{++} leaving the 1st stage equals one unit Sr. This places both B.C.'s at the same end of the contactor section. We may now calculate the Sr^{++} in each stage from the 1st on to the Nth via the "linear" material balance and equilibrium equations until we arrive at the Nth stage. Then check the value of Sr in from stage "N+1" (i.e., Sr in entering LLW stream) to see if it is > 1000 units. If so our guess of N has been sufficiently large.

Calculation of stages and flows in the other sections of this process were carried out by similar means. Total costs were simple functions of total numbers of stages, amortization rate, and mass of algae and $CaCl_2$ required.

ALGAE,7,40,70000.468001,MILLER

*USERPR

RUNF(S)

LGD.

7

```
PROGRAM ALGAE (INPUT,OUTPUT,TAPE5=INPUT,TAPE6=OUTPUT)
C COST ANALYSIS OF ALGAL CLEAN-UP OF LLW STREAMS
  DIMENSION COSTS(101)
  DIMENSION COSTN(100)
  DIMENSION TCOSTA(101)
  DIMENSION A(101)
  DIMENSION CZERD(101)
  DIMENSION TCOSTN(101)
  DIMENSION SL(101)
  DIMENSION DK2(101)
  DIMENSION CA(101)
  DIMENSION C(101)
  DIMENSION CSR(101)
  DIMENSION CS(101)
  DIMENSION AL(101)
  DIMENSION ALG(101)
  DIMENSION CAL(101)
  DIMENSION ALGA(101)
  DIMENSION SUM1(101)
  DIMENSION SUM2(101)
C AMORTIZATION OVER A 20 YEAR PERIOD AT 4 PERCENT INTEREST
C T = TOTAL SUM TO BE AMORTIZED OVER A 20 YEAR PERIOD
C YI = YEARLY INTEREST RATE
C FRY = FRACTION REPAID EACH YEAR
  YI = 0.04
  T = 1.0
  YIFUN = 0.0
  DO 1000 I= 1,20,1
  YIFUN = YIFUN + (1.0+YI)**I
1000 CONTINUE
  FRY = T*((1.0+YI)**20)/(YIFUN+1.0)
C ACPTGWL = AMORTIZATION COST PER THOUSAND GALLONS LLW
  ACPTGWL = FRY/(T*365.0*750.000)
  PRINT 1002 ,FRY,ACPTGWL
1002 FORMAT ( * FRY = *,E12.5 ,* ACPTGWL = *,E12.5)
  S = 0.01
  SS = 0.01
  SSS = 0.01
  ALGCF = 0.02
  ALGCF = 0.04
  ALGCF = 0.01
  ALGCF = 0.08
  ALGCF = 0.03
C CPC = COST PER CENTRIFUGE (INSTALLED = $200,000.00 )
  CPC = 200000.00
  COSTPS = 2.0*CPC*ACPTGWL
  SSTAGCF = 1.0*CPC*ACPTGWL
  COSTPSW = SSTAGCF
  WL = 8000.0
  SLCOSTF = 0.001
  BLEED = 0.1
```

```
CALINWW = 0.000002
AWATER = 10.0
CAINSL = 2.0
CAINSL = 200.0
CAINTOM = 0.000002
CAOUTWS = 0.000004
CAINWL = 0.000002
DK1 = 1.2*0.0014/CAINWL
C(1) = 1.0
DO 5100 KK= 1,100,1
IF (KK-1) 1490,1490,1495
C
1490 GUESS CZERO = 0.001*C(1) INITIALLY
1490 CZERO(KK) = 0.001*C(1)
GO TO 1500
1495 CZERO(KK) = CZERO(KK-1) + 0.010*C(1)
1500 A(1) = 15.0
1550 DO 5000 JJJ = 1,100,1
JJ = 1
IF (JJJ-1) 1600,1600,1560
1560 A(JJJ) = A(JJJ-1) + 5.0
1600 DO 2060 N = 1,100,1
IF (N-100) 1860,5000,5000
1860 IF(N-1) 1870,1870,1875
1870 ALPASS = 1.0
AL(N) = ALPASS
ALZERO = ALPASS*(1.0+S)
CZERO = CZERO(KK)
GO TO 1885
1875 ALPASS = 1.0
AL(N) = ALPASS
CZERO = CZERO(KK)
LLL = N-1
DO 1880 II = 1,LLL,1
LL = N - II
AL(LL) = ALPASS + S*AL(LL+1)
1880 CONTINUE
ALZERO = ALPASS + S*AL(1)
1885 DO 1900 II = 1,N,1
AL(II) = AL(II)*A(JJJ)/ALZERO
1900 CONTINUE
ALZERO = A(JJJ)
1950 SRNET = C(1)*(WL+S*AL(1)*(DK1+AWATER))-CZERO*ALZERO*(DK1+AWATER)
DO 2050 III = 1,N,1
IF (III-N) 2000,2020,2020
2000 C(III+1) = (C(III)*AL(III)*(DK1+AWATER) + SRNET)/(WL+S*AL(III+1))
GO TO 2050
2020 C(III+1) = (C(III)*AL(III)*(DK1+AWATER) + SRNET)/WL
2050 CONTINUE
TEST = C(N+1)-1000.0
IF (TEST) 2060,2065,2065
2060 CONTINUE
2065 PRINT 2070,N,S,AL(N),CZERO(KK),C(N),C(N+1) ,A(JJJ)
2070 FORMAT ( *N = *,I3,* S = *,E12.5,* AL(N) = *,E12.5
1/*CZERO(KK) = *,E12.5,* C(N) = *,E12.5,* C(N+1) = *,
2E12.5,/* A(JJJ) = *,E12.5)
C SUBROUTINE OF PROCESS WITHOUT ALGAE RECYCLE (CARDS 2075 TO 2200)
```

```
C   LMN=1 IS NO RECYCLE,LMN=2 IS THE FULL RECYCLE PROCESS
      LMN =2
      LMN=1
2075 IF (LMN -1) 2080,2080,4000
2080 COSTN(JJJ)= N*COSTPS + A(JJJ)*ALGCF
      PRINT 2090,N,JJJ,A(JJJ),COSTN(JJJ)
2090 FORMAT( *N = *,I3,* JJJ = *,I3,* A(JJJ) = *,
1E12.5,* COSTN(JJJ) = *,E12.5)
      IF (JJJ-1) 5000,5000,2100
2100 TEST7 = COSTN(JJJ) - COSTN(JJJ-1)
      IF (TEST7) 5000,2200,2200
2200 GO TO 5700
      GO TO 4000
3500 DO 4900 JJ = 2,100,1
3610 N = N+1
3660 IF (N-1) 3670,3670,3675
3670 ALPASS = 1.0
      AL(N) = ALPASS
      ALZERO = ALPASS*(1.0+S)
      CZERO = CZERO(KK)
      GO TO 3685
3675 ALPASS = 1.0
      AL(N) = ALPASS
      CZERO = CZERO(KK)
      LLL = N-1
      DO 3680 II = 1,LLL,1
      LL = N - II
      AL(LL) = ALPASS + S*AL(LL+1)
3680 CONTINUE
      ALZERO = ALPASS + S*AL(1)
3685 DO 3700 II = 1,N,1
      AL(II) = AL(II)*A(JJJ)/ALZERO
3700 CONTINUE
      ALZERO = A(JJJ)
3750 SRNET = C(1)*(WL+S*AL(1)*(DK1+AWATER))-CZERO*ALZERO*(DK1+AWATER)
      DO 3850 III = 1,N,1
      IF (III-N) 3800,3820,3820
3800 C(III+1) = (C(III)*AL(III)*(DK1+AWATER) + SRNET)/(WL+S*AL(III+1))
      GO TO 3850
3820 C(III+1) = (C(III)*AL(III)*(DK1+AWATER) + SRNET)/WL
3850 CONTINUE
3865 PRINT 3870,N,S,AL(N),CZERO(KK),C(N),C(N+1),A(JJJ)
3870 FORMAT ( *N = *,I3,* S = *,E12.5,* AL(N) = *,E12.5
1/*CZERO(KK) = *,E12.5,* C(N) = *,E12.5,* C(N+1) = *,
2E12.5,/* A(JJJ) = *,E12.5)
4000 DO 4800 J= 1,10,1
      IF (J-1) 4200,4200,4500
4200 SL(J) = 200.0*8.0 - AL(N)*AWATER
      GO TO 4600
4500 SL(J) = SL(J-1) + 10.0*8.0
4600 DO 4700 M = 1,100,1
      ALGPASS = 1.0
      ALG(1) = ALGPASS
      DO 4640 III = 1,M,1
      ALG(III+1) = SS*ALG(III) + ALGPASS
4640 CONTINUE
```



```
DO 4650 III = 1,M,1
ALG(III) = ALG(III)*AL(N)/ALG(M+1)
4650 CONTINUE
ALG(M+1) = AL(N)
DO 4653 III = 1,M,1
IF (III-1) 4651,4651,4652
4651 SUM1( 1 ) = (ALG( 1 )*AWATER *(1.0+SS) + SL(J))/(ALG(2)*AWATER)
SUM2(III) = SL(J)/(ALG(III+1)*AWATER)
GO TO 4653
4652 SUM1(III) = SUM1(III-1)*(SL(J)+SS*ALG(III-1)*AWATER)/
1(ALG(III)*AWATER)+ALG(1)/ALG(III)
SUM2(III) =SUM2(III-1)*(SL(J) +SS*ALG(III-1)*AWATER)/
1(ALG(III)*AWATER) + SL(J)/(ALG(III)*AWATER)
4653 CONTINUE
CA(1) = (CAINTOM+SUM2(M))/SUM1(M)
DO 4654 III = 1,M,1
CA(III+1) = SUM1(III)*CA(1) + SUM2(III)*CAINSL
DK2(III) = (1.2*0.0014)/CA(III)
GO TO 4654
PRINT 4655,CA(III),DK2(III) ,III
4655 FORMAT( *CA(III) = *,E12.5,* DK2(III) = *,E12.5,* III = *,I3)
4654 CONTINUE
DK2(M+1) = DK1
CA(M+1) = CAINTOM
CSRPASS = 1.0
CSR(1) = CSRPASS/ALG(1)
DO 4660 IIJ = 1,M,1
CSR(IIJ+1) = ((SS*ALG(IIJ)*(DK2(IIJ)+AWATER)+SL(J))*CSR(IIJ)+
1CSRPASS)/(ALG(IIJ+1)*(DK2(IIJ+1)+AWATER))
GO TO 4660
4656 FORMAT( * CSR(IIJ) = *,E12.5,* IIJ = *,I3)
PRINT 4656,CSR(IIJ),IIJ
4660 CONTINUE
DO 4670 IIJ = 1,M,1
CS(IIJ) = CSR(IIJ)*C(N)/CSR(M+1)
4670 CONTINUE
CSR(M+1) = C(N)
TEST2 = C(N+1)/(C(1)+CS(1)) -1000.0
IF (M-100) 4681,3500,3500
4681 DUMMY = 1.0
IF (TEST2) 4700,4683,4683
4700 CONTINUE
4683 DUMMY = 1.0
PRINT 4682,J,SL(J),M,ALG(1),CS(1)
4682 FORMAT ( * J = *,I3,* SL(J) = *,E12.5,* M = *,I3,/
1*ALG(1)= *,E12.5,* CS(1) = *,E12.5)
WW = 8.0*500.0-ALG(1)*AWATER
DO 4689 MM = 1,100,1
ALGPASS = 1.0
ALGA(1) = ALGPASS
DO 4684 III = 1,MM,1
ALGA(III+1) = SSS*ALGA(III) + ALGPASS
4684 CONTINUE
LL = MM+1
DO 4685 III = 1,LL,1
ALGA(III) =ALGA(III)*ALG(1)/ALGA(MM+1)
```

```
4685 CONTINUE
      DO 4688 III = 1,MM,1
      IF(III-1) 4686,4686,4687
4686 SUM1(1)=(ALGA(1)*AWATER*(SSS+1.0)+WW)/(ALGA(2)*AWATER)
      SUM2(1) = WW/(ALGA(2)*AWATER)
      GO TO 4688
4687 SUM1(III) =SUM1(III-1)*(WW+SSS*ALGA(III-1)*AWATER)/
      1(ALGA(III)*AWATER) + ALGA(1)/ALGA(III)
      SUM2(III) = SUM2(III-1)*(WW+SSS*ALGA(III-1)*AWATER)/
      1(ALGA(III)*AWATER) + WW/(ALGA(III)*AWATER)
4688 CONTINUE
C     CAL(MMM+1) = SUM1(MM)*CA(1) +SUM2(MM)*CALINWW
      CAL(1) =(CA(1)-SUM2(MM)*CALINWW)/SUM1(MM)
      IF (CAL(1) - CAOUTWS) 4690,4690,4689
4689 CONTINUE
4690 PRINT 4691,MM,ALGA(1),CAL(1)
4691 FORMAT ( *MM = *,I3,* ALGA(1) = *,E12.5,*CAL(1) = *,E12.5
      1)
4750 COSTS(J)=SL(J)*SLCOSTF+M*SSTAGCF +MM*COSTPSW
      ACDST = S*AL(1)+SS*ALG(M)+BLEED*A(JJJ)+SSS*ALGA(MM)
      COSTN(JJ) = N*COSTPS + ACDST*ALGCF
4751 PRINT 4752,J,COSTS(J)
4752 FORMAT ( * J = *,I3, * COSTS(J) = *,F10.5 )
      IF (J-1) 4800,4800,4775
4775 TEST3 =COSTS(J) - COSTS(J-1)
      IF(TEST3) 4800,4800,4850
4800 CONTINUE
4850 TCOSTN(JJ) = COSTS(J - 1) + COSTN(JJ)
4851 PRINT 4852,JJ,TCOSTN(JJ),ACDST,COSTN(JJ)
4852 FORMAT ( * JJ = *,I3,* TCOSTN(JJ) = *,E12.5,/
      1* ACDST = *,E12.5,*COSTN(JJ) = *,E12.5 )
      IF (JJ-1) 4900,4900,4875
4875 TEST4 = TCOSTN(JJ) -TCOSTN(JJ-1)
      IF (TEST4) 4900,4950,4950
4900 CONTINUE
4950 TCOSTA(JJJ) = TCOSTN(JJ - 1)
4951 PRINT 4952 ,JJJ,TCOSTA(JJJ)
4952 FORMAT ( * JJJ = *,I3,* TCOSTA(JJJ) = *,F10.5 )
      IF (JJJ-1) 5000,5000,4975
4975 TEST5 = TCOSTA(JJJ) - TCOSTA(JJJ-1)
      IF (TEST5) 5000,5050,5050
5000 CONTINUE
5050 TEST6 = CZERO(KK)*(DK1+AWATER)-CS(1)*(DK2(1)+AWATER)
5051 PRINT 5052,KK,TEST6
5052 FORMAT( * KK = *,I3,* TEST6 = *,F10.5)
      IF (TEST6) 5100,5500,5500
5100 CONTINUE
5500 PRINT 5600 ,KK ,TEST6,CZERO(KK),
      1JJJ ,TEST5,TCOSTA(JJJ-1),
      2JJ ,TEST4,TCOSTN(JJ-1),
      3J ,TEST3,SL(J-1),COSTS(J-1),
      4M,TEST2,CS(1),DK2(1),DK2(M),DK1,
      5N,C(N+1),C(N),A(JJJ),ALGCF
5600 FORMAT ( *KK = *,I3,* TEST6 = *,E12.5,
      9* CZERO(KK) = *,E12.5/
      1*JJJ = *I3,* TEST5 = *,E12.5,* TCOSTA(JJJ-1) = *,E12.5
```

```
2/*JJ = *,I3,* TEST4 = *,E12.5,* TCOSTN(JJ-1) = *,E12.5
3/*J = *,I3,* TEST3 = *,E12.5,* SL(J-1) = *,E12.5,
8* COSTS(J-1) = *,E12.5/
4*M = *,I3,* TEST2 = *,E12.5,* CS(1) = *,E12.5,
6/*DK2(1) = *,E12.5,* DK2(M) = *,E12.5,* DK1 = *,E12.5/
5*N = *, I3 ,* C(N+1) = *,E12.5,* C(N) = *,E12.5,
5* A(JJJ) = *,E12.5,* ALGCF = *,E12.5)
5700 DUMMY = 1.0
STOP
END
```

APPENDIX D*

AMINO ACID ANALYSIS PROCEDURE

Procedure for Hydrolysis of the Algae

(Ref: S. Blackburn, AMINO ACID DETERMINATION,
Marcel Dekker, Inc., New York, 1968 pp. 13-22)

1. 1.00 g. lyophilized algae was suspended in 10-15 ml. 6N HCl and stirred approximately 30 minutes. The suspension was carefully transferred to a glass ampule with an additional few ml of 6N HCl.
2. The ampule was sealed under nitrogen and placed in a constant temperature oil bath at $120 \pm 4^{\circ}\text{C}$ for 24 hours.
3. The excess acid was removed by distillation in vacuo. The residue was dissolved in sodium citrate diluting buffer (pH 2.2) and made to 10 ml. in a volumetric flask.
4. The solution was filtered through 0.8 μ Millipore filter. 1.0 ml. of this filtrate was used for total amino acid analysis.

Notes: Under acid hydrolysis conditions, various amino acids are totally or partially destroyed. It has been estimated that 10-20% of serine and threonine may be lost, 20% of cystiene, and all of tryptophan. In addition, losses of tyrosine and proline have been recorded. These facts must be considered when analyzing the data provided.

* Procedure used by McGaw Labs.

REFERENCES

1. Morgen, George B. "The Absorption of Radioisotopes by Certain Micro-organisms", Quarterly Journal of the Florida Academy of Sciences, 24:2, 1961.
2. Jennings, D. The Absorption of Solutes by Plant Cells. New York: 1963.
3. Knight, A. H., et al, "Cation-Exchange Capacities of Tissues of Higher and Lower Plants", Nature 192, 1961.
4. Austin, J., "Absorption of Strontium by *Chlorella Pyrenoidosa*", Ph.D. Thesis, University of California, Berkeley, 1962.
5. Tuominen, Y. "Studies of the Strontium Uptake of the *Cladonia alpestris* thallus", Ann. Bot. Fenn. 4, 1967.
6. Helffrich, Friedrich. Ion Exchange, New York: McGraw-Hill, 1962.
7. King, L. J. "Pilot Plant Demonstration of the Decontamination of Low-Level Process Wastes by a Recycle Scavenging-Precipitation Ion Exchange Process", U. S. Atomic Energy Commission Report, 1965.
8. De Lavel Centrifuge Co., Private Communication.
9. Golueke, C. G. and W. J. Oswald, "Harvesting and Processing Sewage Grown Planktonic Algae", Journal of Water Pollution Control Federation, April, 1965.
10. Chilton, C. H. Cost Engineering, New York: McGraw-Hill, 1960.
11. Oil and Drug Reporter, August, 1970.
12. U. S. Department of Agriculture results of amino acid analysis of *Pandorina morum*, Private Communication, 1968.
13. McGaw Labs results of amino acid analysis of *Pandorina morum*, Private Communication, 1971.

14. Joint FAO/WAO Expert Group. "Protein Requirements", FAO Nutrition Meeting Report Series 37, and WHO Technical Report Series 301, 1965.
15. Kohler, G. O. and Rhoda Palter. "Studies on Methods for Amino Acid Analysis of Wheat Products", Cereal Chemistry, 44:5, 1967.
16. Houston, D. G., Marian Allis, and G. O. Kohler. "Amino Acid Composition of Rice and Rice By-Products", Cereal Chemistry, 46:5, 1967.

LEGAL NOTICE

This report was prepared as an account of work sponsored by the United States Government. Neither the United States nor the United States Atomic Energy Commission, nor any of their employees, nor any of their contractors, subcontractors, or their employees, makes any warranty, express or implied, or assumes any legal liability or responsibility for the accuracy, completeness or usefulness of any information, apparatus, product or process disclosed, or represents that its use would not infringe privately owned rights.

TECHNICAL INFORMATION DIVISION
LAWRENCE BERKELEY LABORATORY
UNIVERSITY OF CALIFORNIA
BERKELEY, CALIFORNIA 94720