

Lawrence Berkeley National Laboratory

Recent Work

Title

INTERPHASE TRANSFORMERS FOR PARALLEL INVERTERS

Permalink

<https://escholarship.org/uc/item/8qf025fn>

Author

Rovelsky, Leon Arnold.

Publication Date

1954-05-20

UCRL 2561
UNCLASSIFIED

UNIVERSITY OF
CALIFORNIA

*Radiation
Laboratory*

TWO-WEEK LOAN COPY

*This is a Library Circulating Copy
which may be borrowed for two weeks.
For a personal retention copy, call
Tech. Info. Division, Ext. 5545*

BERKELEY, CALIFORNIA

UCRL-2561
C.2

DISCLAIMER

This document was prepared as an account of work sponsored by the United States Government. While this document is believed to contain correct information, neither the United States Government nor any agency thereof, nor the Regents of the University of California, nor any of their employees, makes any warranty, express or implied, or assumes any legal responsibility for the accuracy, completeness, or usefulness of any information, apparatus, product, or process disclosed, or represents that its use would not infringe privately owned rights. Reference herein to any specific commercial product, process, or service by its trade name, trademark, manufacturer, or otherwise, does not necessarily constitute or imply its endorsement, recommendation, or favoring by the United States Government or any agency thereof, or the Regents of the University of California. The views and opinions of authors expressed herein do not necessarily state or reflect those of the United States Government or any agency thereof or the Regents of the University of California.

UNIVERSITY OF CALIFORNIA
Radiation Laboratory

Contract No. W-7405-eng-48

INTERPHASE TRANSFORMERS FOR PARALLEL INVERTERS

Leon Arnold Rovelsky

(Thesis)

May 20, 1954

Berkeley, California

INTERPHASE TRANSFORMERS FOR PARALLEL INVERTERS

Contents

	Page
Abstract	3
I. Introduction	5
II. Rectifiers and Inverters	7
III. The Interphase Transformer	22
IV. The Analogue of the Interphase Transformer	31
V. Evaluation of Experimental Results	41
VI. Conclusions	49
Acknowledgments	51
Appendices:	
A. Outline for a Sample Design of an Interphase Transformer	52
B. General Form for Voltage Equations Appearing Across an Interphase Transformer	53
C. Complex Form for Voltage Equations Appearing Across an Interphase Transformer Due to a Particular Wave Shape	58
References	61

INTERPHASE TRANSFORMERS FOR PARALLEL INVERTERS

Leon Arnold Rovelsky

Radiation Laboratory, Department of Physics
University of California, Berkeley, California

May 20, 1954

ABSTRACT

Interphase transformers are investigated for the purpose of determining their capabilities and limitations in equalizing the load and absorbing the difference voltages when operated between parallel inverters. The general features of rectifiers and inverters are reviewed, listing difficulties encountered when inverters are operated in parallel. The fundamental operating principles of the interphase transformer are illustrated through the device of an analogue.

Specifications that govern the size of an interphase transformer are determined by using a series of voltage curves. These curves are then used in developing the procedure for a sample design.

A resume and actual examples of certain difficulties experienced with the paralleling of the inverters of the Bevatron Magnet Power Supply of the University of California Radiation Laboratory are included in the text.

Polyphase inverters are compared with polyphase rectifiers to show their significant differences and similarities.

The analogue device, which portrays the fundamental characteristics of the interphase transformer, was made by modifying two iron-core filter choke coils. From the experimental study of the analogue interphase transformer a determination of the requirements for an actual interphase transformer were developed. Cognizance of the voltage difference curves being instantaneously applied across the interphase transformer is shown to be important in the determination of the ultimate size of the interphase transformer.

Voltage difference curves are included to show the effects of commutation angle and firing angle on the requirements of interphase transformer size. The complex wave forms encountered are inspected in more detail in the appendices.

The reasons for paralleling difficulties of inverters are illustrated by means of block diagrams. These block diagrams show how positive feedback makes for instability while negative feedback makes for stability and also reduces the requirements for the interphase transformer.

The conclusions summarize factors that must be considered for equal division of load and minimum ripple for parallel inverters.

INTERPHASE TRANSFORMERS FOR PARALLEL INVERTERS

Leon Arnold Rovelsky

Radiation Laboratory, Department of Physics
University of California, Berkeley, California

May 20, 1954

I. INTRODUCTION

When identical units of any device are operated in parallel, it is generally expected that they will equally divide or share the common load. The difficulties experienced with the equipment with which we are concerned were enhanced because of the transient nature of the load.

It was found that during the rectification portion of the pulsing cycle the load was shared equally by the two parallel rectifiers.⁵ During the inversion portion of the pulse cycle, however, the load was not shared equally by the two parallel inverters. In fact, the division of the load was most unpredictable, even though operating conditions were made as nearly identical as possible on commercially designed equipment.

One of the undesirable effects of the unequal sharing of the load by the asynchronous parallel inverters was the overspeeding of the inverter receiving most of the energy. The inverter receiving the less energy rotated more slowly and therefore took a longer time to get back up to speed. This type of operation could not be continuous, as all the control equipment for the drive motors was a common system which required a close, if not identical, speed match.

Another unfavorable factor due to unequal load division was excessive current, higher than the ratings of the inverter taking the greater part of the load.

Since the flywheel motor-generator sets were able to operate at these variable frequencies with respect to each other--that is, they were asynchronous--it was difficult to decide just what caused the unequal division of load, because all the factors affecting the characteristics were thought to have been made equal.

Because of the difficulties encountered it was decided to change from asynchronous to synchronous operation. This change was made by placing the two series circuits of each machine in parallel with each other rather than in parallel with the opposite machine, as they had been.

What it really meant was that the load current would provide equal power to each shaft as long as the voltages of the inverters were equal. Any variation in voltage would not be large, and thus there would be only small variations in the speeds of the two machines. This change assured continuous running of the equipment.

However, even after this change to synchronous condition, the inverters that were parallel circuits of the same machine did not choose to divide the load equally. To effect close division of load between these synchronous parallel inverters it was necessary to make further changes in the firing circuits, which introduced negative feedback. After changes had been made, the load was forced to divide in proportion to the error or difference signals that were introduced in the firing circuits.

During all these changes and tests, I felt that the interphase transformers should be investigated more thoroughly. Very little information was available about specific design data on interphase transformers for parallel inverters, so it was decided to inspect closely the requirements placed on an interphase transformer and to try to find the limitations of the actual interphase transformer.

Because of limited expense funds, facilities, and time for duplicating an actual interphase transformer and a suitable parallel inverter, it was necessary to find a simple experimental means of representation. This was accomplished by developing an analogue using choke coils. With small and easily controlled components in the analogue, it was possible to find boundary conditions for the analogue interphase transformer and to interpret the results into the corresponding effects on an actual interphase transformer used between parallel inverters.

II. RECTIFIERS AND INVERTERS

In order to make a better evaluation of the requirements for an interphase transformer for parallel inverters, a resumé is given here of three-phase parallel rectifiers that use interphase transformers.

Inverters and rectifiers are inseparably bound together. There are certain similarities as well as considerable differences.

The discussion in this paper is concerned mainly with three-phase synchronous components, but asynchronous conditions are also discussed. However, when the asynchronous or varying-frequency condition is being described, it is so stated; in all other descriptions it is understood that the condition is synchronous.

An interphase is used between two three-phase half-wave rectifiers (wye-wye) to give better ripple voltage output (six-phase) and greater rectifier efficiency (three-phase).

For the interphase to be effective, it must have a voltage appear across its terminals. This voltage is induced by the flux which is created by the exciting currents. The excitation current flows because of the instantaneous difference voltages that are applied at its terminals. As long as the iron in the core is not saturated, an induced voltage appears as a result of exciting current changes. If the iron is completely saturated, the interphase transformer is not excited and does not induce the opposing voltage. Thus only an IR voltage drop, due to current and resistance, appears across the unexcited interphase transformer.

If the three-phase double-wye (Fig. 1a) combination is operated without the interphase transformer, or with an unmagnetized (unexcited) interphase transformer, the load current transfers from phase to phase as if it were a standard six-phase rectifier. This type of operation requires larger rectifier tubes because they carry the total current for 60° of the cycle time, plus the overlap or commutation angle time. (Commutation or overlap angle is defined as the time required for the current to transfer from one phase to the next following phase.¹)

If one does not consider the overlap or commutation angle (i. e., commutation angle equals zero), the average dc voltage is $1.35 E_{\text{rms}}$ ¹ (line to neutral). But when the overlap angle is considered, the average value of the dc voltage is correspondingly lower.¹

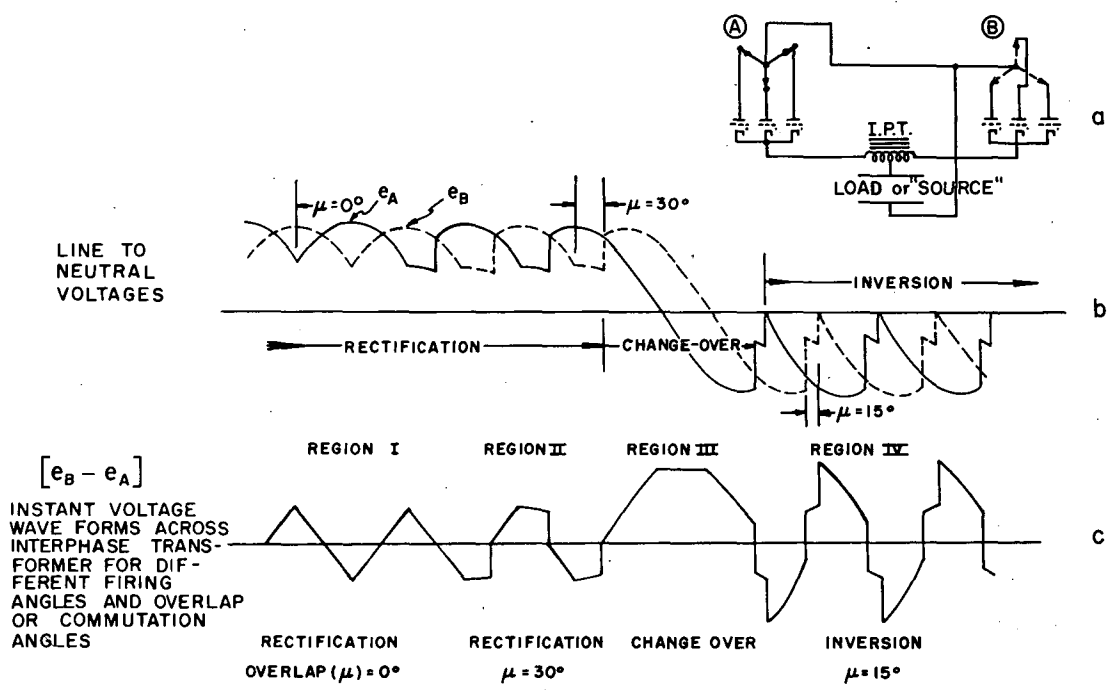

Fig. 1--- Interphase Transformers for Parallel Inverters

MU-7982

Figure 1

If this same combination of half-wave rectifiers is connected through an interphase transformer, the dc voltage for zero commutation angle is $1.17 E_{\text{rms}}$ (line to neutral). Under such conditions each tube of each three-phase rectifier wye conducts current for one-third of the cycle time. The magnitude of the current in each half of the parallel units is one-half of the total current. The interphase transformer absorbs the differential components of the parallel voltages so that a six-phase ripple appears across the load.

The output voltage of a three-phase double-wye half-wave rectifier is

$$e_{\text{dc}} = 1.17 E (1 + 0.057 \cos 6\omega t . . .) \quad (1)$$

when the individual voltages simultaneously applied across the interphase transformer are

$$e_{\text{d1}} = 1.17 E (1 + 0.25 \cos 3\omega t - 0.57 \cos 6\omega t + 0.025 \cos 9\omega t . . .) \quad (2)$$

$$e_{\text{d2}} = 1.17 E (1 + 0.25 \cos 3(\omega t + 60^\circ) - 0.57 \cos 6(\omega t + 60^\circ) + 0.025 \cos 9(\omega t + 60^\circ) \quad (3)$$

If the two wyes are connected in such a manner that each of the three-phase components are in phase rather than the 180° out of phase as shown in Fig. 1a, then the two voltages e_{d1} and e_{d2} are in phase. They are identical and there is no voltage difference across the interphase transformer. The voltage across the load, or output voltage, is exactly the same as each of the applied voltages and all the harmonics appear. If the voltage sources supplying each of the two three-phase half-wave rectifiers are equal and also have equal impedances, the load should divide equally between each of the two halves of the system.

When rectifiers (or inverters) are receiving energy from two separate generators, each driven by its own prime mover and free to have its own frequency, any position of relative phase displacement between the rectifiers is possible--e.g., from 180° out of phase to exactly in phase. This is called asynchronous operation. In asynchronous operation, the phase position and relative frequency can be continually variable.

When polyphase rectifiers have grid-controlled firing, it is possible to reduce the dc output voltage by delay of the firing. Sufficient delay can reduce the average dc voltage to zero.

While in the region of maximum dc voltage to zero dc voltage, the units are considered to be rectifiers. However, when the firing instant is delayed even more, the net output voltage is negative, and the power conversion is considered to be in the region of inversion. Under these conditions, power flows in the reverse direction. The voltage is negative while the current can flow in only one direction. Inversion can exist only if there is an external source of power. (In rectification, the portion of the circuit that was formerly the load now becomes the source of power.) Equations (4) and (5) indicate direction of power flow.

$$\text{Rectification Power} = (+ E) (I) = + \text{Watts} \quad (4)$$

$$\text{Inversion Power} = (- E) (I) = - \text{Watts} \quad (5)$$

Significant features of inverter operation that differ from the corresponding features of rectifiers are:

- (a) Inverters receive energy, whereas rectifiers deliver energy or power.
- (b) The lower the inverter voltage, the greater the current, whereas the higher the rectifier voltage, the greater the current.
- (c) Inverter voltage increases with delay in firing angle, whereas rectifier voltage decreases with delay in firing angle.
- (d) When inverters operate in parallel, the inverter with the lowest magnitude of voltage takes the most current, whereas when rectifiers operate in parallel, the rectifier with the highest magnitude of voltage takes the most current.
- (e) In the case of two identical parallel polyphase rectifiers without an interphase transformer and both feeding the same load, the division of load will be equal as long as the voltages are identical. However, if one rectifier has a slightly higher voltage than the other, it will deliver slightly more current.

In the case of two identical parallel inverters without an interphase transformer and both feeding a common load, the division of load will be exactly equal as long as the voltages are identical. In this case, however, the inverter with the less voltage will receive the larger current. If the voltage of the inverter with the less current is permitted to rise to a value equal to that of the source of energy, it will take no current and the other inverter will take all the current.

In low-impedance circuits, a close balance of parallel inverter voltages must be maintained; the degree of exactness is dependent upon the ability of the interphase transformer to absorb any instantaneous voltage differences. If, however, the load current unbalances, the interphase transformer becomes magnetically unbalanced, the degree of unbalance correction being proportional to the flux of the interphase transformer. If the unbalance is not permitted to go beyond a point on the saturation curve (Fig. 2b), the interphase transformer is able to provide compensating voltage. The current is forced to reduce in the higher-current circuit, and vice versa in the lower-current circuit. Thus equal division of load is again attained.

Under static conditions this can be readily effected by adjustments in long time-constant circuits. In transient parallel inverters, however, there must be rapid reaction to changes--so rapid, in fact, that a predictor regulator would be feasible.

In the Bevatron equipment there were a number of ways that the current division could have been measured in the various parts of the rectifier-inverter circuits. However, the easiest method by which to indicate and record the division of direct current in the power-supply circuits was to place a simultaneous display of the current in the ac side of the load-current transducers on the screen of a dual-beam oscilloscope (2.5 amperes ac being the equivalent of 5,000 amperes dc). The envelopes of the ac displayed on the oscilloscope screen thus gave a proportional indication of dc current magnitude, and the dual beams gave the simultaneous division of the load between parallel halves of the inverter.

The asynchronous rectifier-inverter units were originally connected in parallel,^{5, 6} one half of each machine in parallel with one half of the other machine.

Occasionally the division of load would be equal, but for most pulses the current was unequally divided. Therefore, it was eventually decided to change to a series connection of the two sets of inverter units. Even after the change to the series connection was made using temporary cables, the load current still would not divide equally within each machine. There had to be some very fundamental reason for this unequal division!

ALL CURRENTS AND FLUX ARE DECREASING

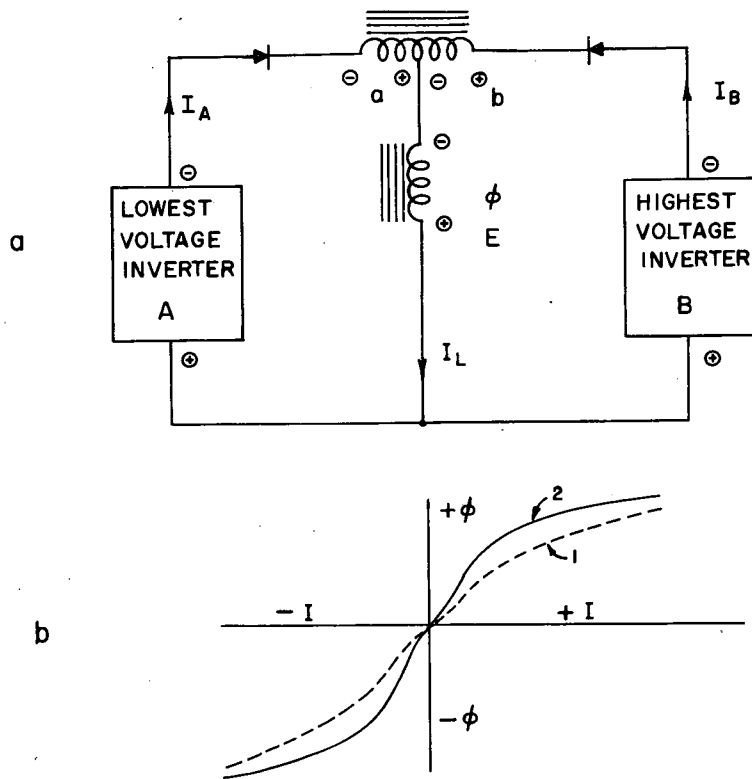
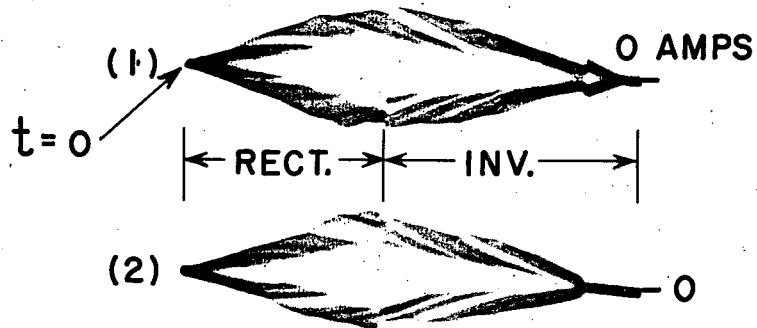

Fig. 2 --- I.P.T. for Parallel Inverters

MU-7983

Figure 2

(a) EQUAL DIVISION OF CURRENT



(b) UNEQUAL DIVISION OF CURRENT

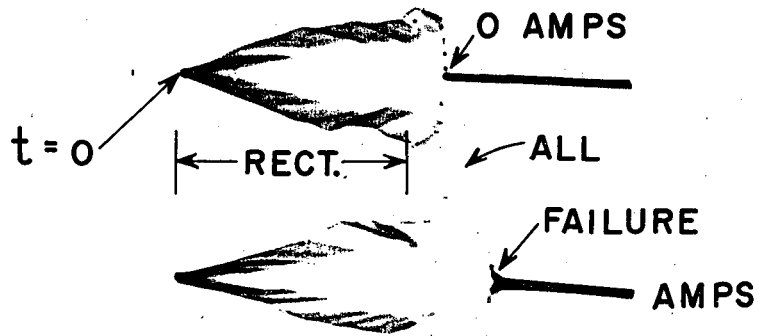

TRANSDUCTOR CURRENT

MU-8001

Figure 3

A series of oscillograms, with explanations of each, appears below, showing the division of current between halves of the rectifier-inverter paths.

Figure 3a shows what is considered good division of current, or sharing of the load of each half of a rectifier-inverter combination. The positive slope (increasing values) is the rectification interval; the negative slope (decreasing values) is the current division during inversion. Figures 3a-1 and 3a-2 are quite similar. This indicates a good pulse of power in that the load was equally divided. Under such conditions the speed of the motor-generator sets would be equal for the duration of the pulse and this would permit continuous pulsing.

The current division shown in Fig. 3b is very nearly equal during rectification, but after inversion, the division of load changed completely, with one half of the machine taking all the load, while the other carried no current. Very shortly thereafter a fault occurred because of inversion arc-through. When such a fault occurs during operation of the Bevatron power supply equipment, the dc field of the generator is removed and the magnet is short-circuited. The magnet current then decays according to the characteristics of the magnetic circuit, the time constant of which is about 16 seconds. All the energy of the magnetic field is lost as I^2R dissipated heat. The motors that drive the flywheels and generators are required to draw the difference and normal losses from the power company lines.

The positive slope of the current envelopes of Fig. 4a shows that even though the division of current between the two halves is very close during rectification, a pattern of unequal division of load was established at the beginning of the inversion portion of the cycle. The load finally shifted to one of the halves just before the end of the cycle. Initial conditions for this particular pulse were the same as those of the pulse represented by Fig. 3a. Thus, for no obvious reason, the units did not divide the current equally. When it was observed that the load would shift completely, from one path to the other in the parallel connection, an attempt was made to force paralleling by cross-feeding a proportional dc load current signal in the inverter phase-shifting circuits of the firing-control peaking transformers to the corresponding half of the other asynchronous inverter.

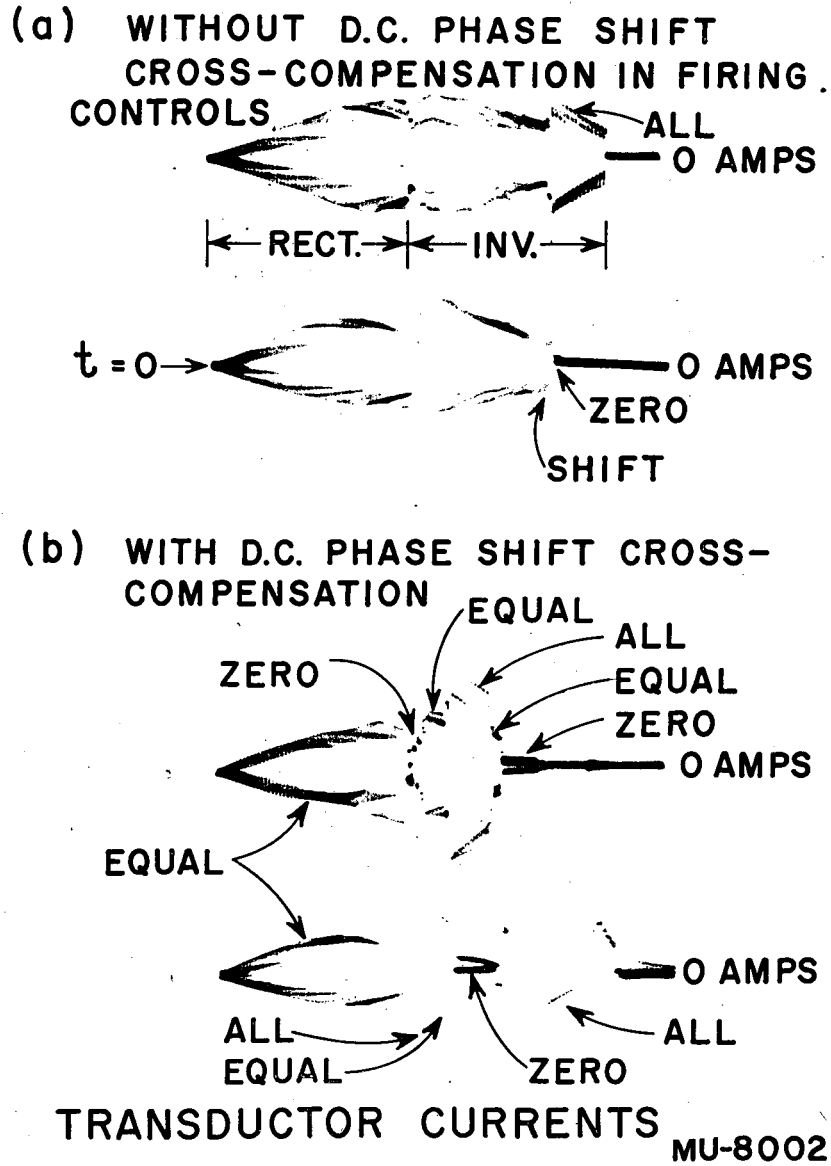
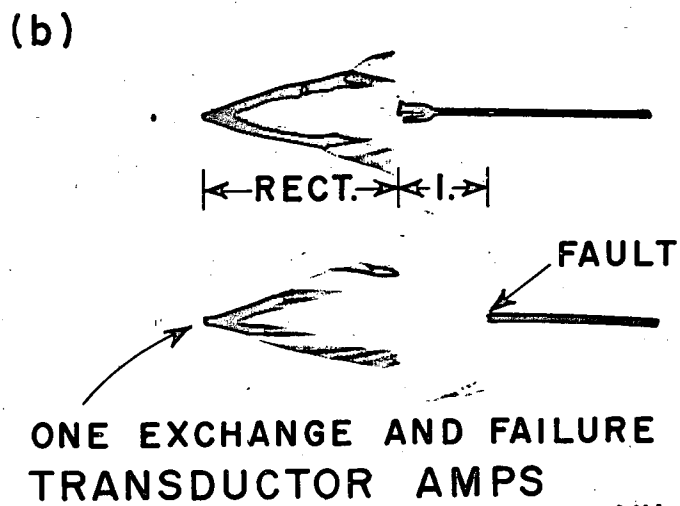
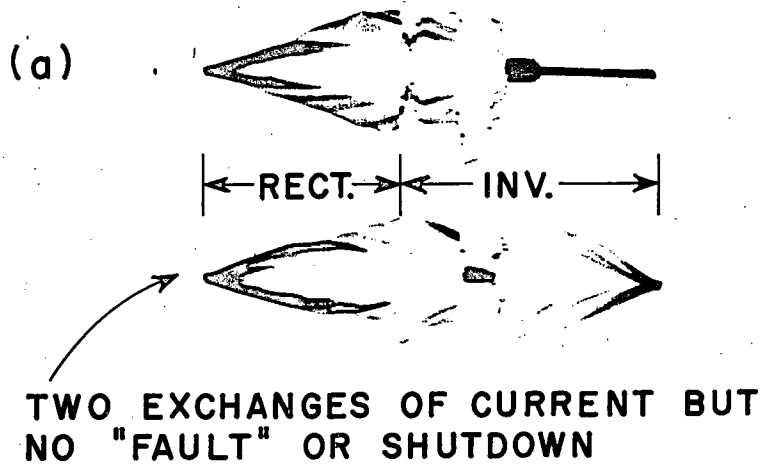

Figure 4

**WITH D.C. PHASE SHIFT CROSS-
COMPENSATION**



MU-8003

Figure 5

This approach to a solution was correct. The only drawback was that the response in the circuit was too slow to do any good when it was needed; furthermore, the delayed response made things as bad or possibly even worse. This created the conditions for a low-frequency multivibrator in which the power at lower energies could transfer from one half to the other and back, etc. At high energies, where the loading was such that the current was too great for one unit to handle by itself, the system would fault and the pulsing cycle would thereupon end (Figs. 4b, 5a, and 5b).

The series connection also had its difficulties. The load would shift from one half of the same machine to the other and vice versa, with no general pattern of change--in fact, almost at random. A better division of load was effected by cross-feeding the primary voltages for the peaking transformers which controlled the firing of the ignitrons. The procedure regulated the inverter voltages in such a manner that the error signals introduced negative feedback. The magnitude of the voltage differences (error signal) thus was made differentially effective within one-third of a cycle, since these inverters were three-phase half-wave units.

Figure 4b shows how the load can be shifted back and forth from one path to the other by introducing negative feedback, but with so much time delay that it causes multivibrator action.

Figures 5a and 5b show a similar display of current division when cross-compensation is used in the dc phase-shifting circuits. Neither of these is an acceptable example of good inversion. Figure 5a shows complete exchanges of current but with the cycle going to completion. In 5b the current transferred and faulted because of inversion arc-through brought about by "running out of margin angle."²

If the voltage applied to the primary of a peaking transformer becomes less, the leading edge of the firing peak is advanced. Advancing the firing peak corresponds to less delay in firing. This causes a lower inverter voltage. The inverter with the lower inverter voltage (between a pair of inverters) takes more current, making its voltage even less. This continues ad infinitum, until the lower voltage unit has taken all the current.

Figure 6 illustrates positive feedback of parallel inverters without an interphase transformer in the following manner:

Let $I_L = I_1 + I_2$, and assume that I_2 , for some reason, is slightly larger than I_1 . This causes $I_2 K Z_2$ to become larger. E_2 , which is $(E_g - I_2 K Z_2)$, becomes smaller. Then $(E_L - E_2)$ becomes larger; this,

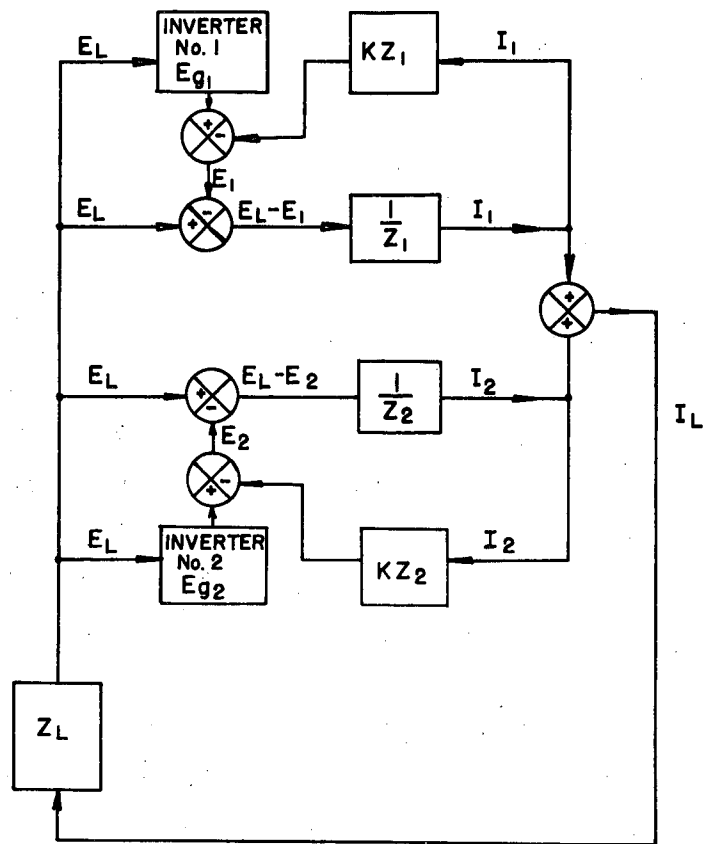

Fig. 6 --- Block Diagram Showing Positive Feedback for Parallel Inverters

MU-7984

Figure 6

in turn, makes I_2 larger because it is equal to $(E_L - E_2/Z_2)$. Correspondingly, I_1 becomes smaller. This shows how the larger current keeps getting larger, while the lesser becomes even less. It is, of course, an unstable condition, and this explains why the Bevatron inverters would not originally divide the currents so as to operate successfully in parallel during inversion.

Eventually, after much experimentation, the primary windings of the peaking transformers were cross-connected to the opposite machine. The inherent change in firing angle due to change in the voltage on the primary gave the effect of negative feedback. This caused the two inverters to parallel quite well. Current division between the two units became a repetitive reality.

Figure 7 represents negative feedback without an interphase transformer. This is a modification of Fig. 6 in which the inherent drop of voltage due to greater load current in the inverter is compensated by taking signal voltages from opposite inverters E_{g1} and E_{g2} and then cross-feeding the signal. Assume again that I_2 is slightly larger than I_1 ; then $-I_2KZ_2$ plus KE_{g1} is greater than $-I_2KZ_2$. E_{g2} becomes larger. This makes $(E_L - E_{g2})$ become smaller than before. Since $I_2 = (E_2 - E_{g2}/Z_2)$, I_2 will become smaller. Conversely, I_1 will become larger. The degree of equality of currents that can exist under such a control system is a function of the response of the various circuit elements.

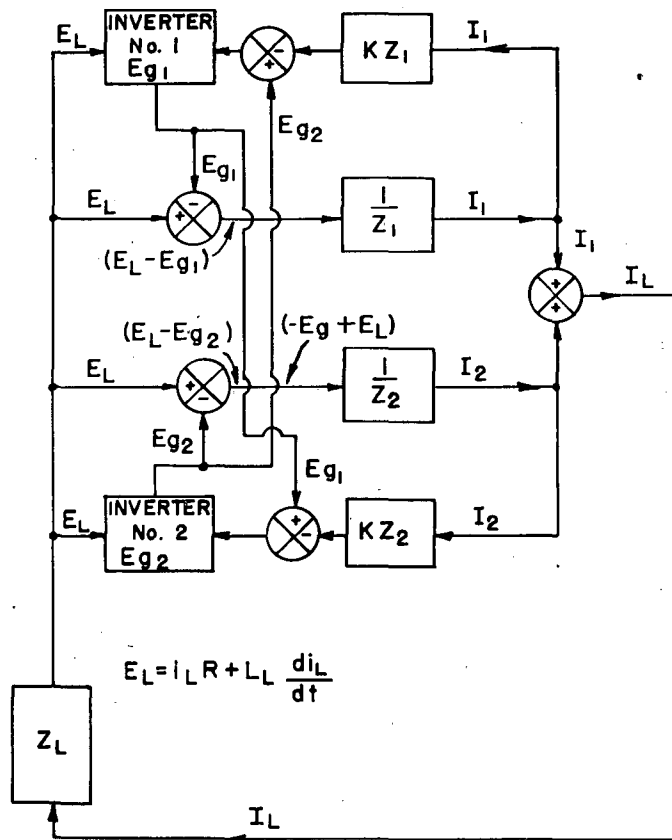
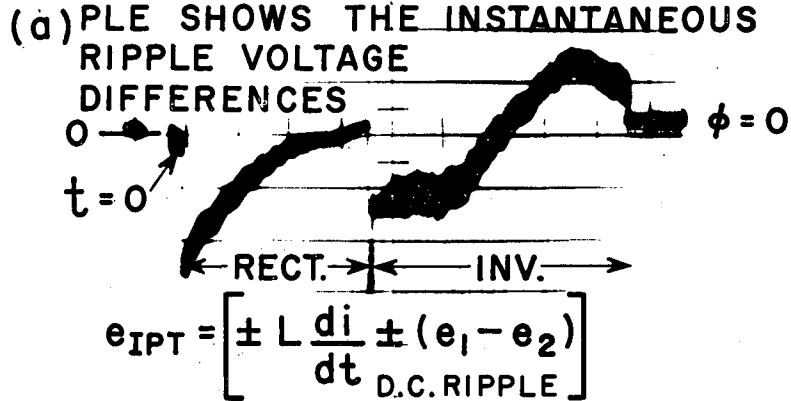

Fig. 7---Block Diagram Depicting Negative Feedback for Parallel Inverters

MU-7985

Figure 7

GOOD PULSE - THE DEVIATION FROM ZERO SHOWS THE D.C. CURRENT UNBALANCE. THE WIDTH OF FLUX RIPPLE SHOWS THE INSTANTANEOUS RIPPLE VOLTAGE DIFFERENCES



(b) GOOD RECTIFICATION BUT POOR INVERSION, HAVING FOUR CURRENT EXCHANGES.

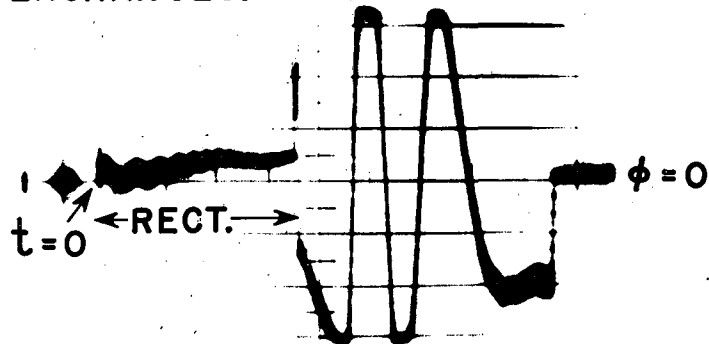

I.P.T. "FLUX"

MU-8004

Figure 8

III. THE INTERPHASE TRANSFORMER

During all this experimentation there seemed to be one troublesome factor concerning the unequal division of load by the parallel inverters: the role of the interphase in the general pattern.

I had observed that in case of bad shifts of load and at change-over from rectification to inversion there were indications of heavy magnetic shock forces applied to the interphase transformers.

The dc output ripple voltage was alternately high or low, but always high when the load was unbalanced. This ordinarily indicates that either the interphase transformer is saturated or that the two inverters are exactly in phase.

But--why did the inverters parallel correctly at times? On these rare occasions the ripple voltage was of lesser magnitude. Possibly the interphase transformer was too small to be always effective during inversion. What was the criterion for the correct interphase transformer?

In order to ascertain in some measure what was happening within the interphase transformer, a search coil was wound on the core of the interphase transformer. The series of oscillograms labeled "I. P. T. Flux" are included to illustrate the magnetic history of the interphase transformer during certain pulses.

Figure 8a shows a flux pattern of the interphase transformer during what was considered to be a good pulse. The vertical width of the trace is the measure of the flux ripple. The deviation from zero flux indicates the magnitude and direction of the core saturation level. This deviation is caused by current unbalance between the parallel rectifiers or inverters. The portion of the pulse labeled "R" is for rectification, while that labeled "INV" is for inversion.

In Fig. 8b the inversion portion of the cycle shows five wide flux excursions, from positive saturation to negative saturation. This is caused by cross-feeding a low-value dc forcing function in the inverter peaking transformer phase-shift windings. The delayed response is due to the relationship between the large time constant of the phase-shift windings and the magnitude of the error signal. It indicates that unless the load division is fairly equal from the normal external characteristics of the equipment, the paralleling effect of the interphase transformer is weak. (This does

not imply that an interphase transformer cannot be made into a stronger paralleling force.)

Figure 9b shows a good pulse, some unbalance beginning during rectification, and the current suddenly shifting to the opposite half during inversion. During inversion the ac cross excitation of the primary windings of the inverter firing circuits keeps the load acceptably divided. In Fig. 9b the current during rectification divides reasonably well.

The air gap of this interphase transformer was originally $3/8$ inch but was later changed to $3/4$ inch. Comparison of the rate of rise (slopes) during rectification on Fig. 9a and 9b-- $3/8$ inch gap--with that of Fig. 10a-- $3/4$ inch gap--shows the effect of increasing the air gap. The increased length of air gap permits a greater unbalance in current before saturating, but it also reduces the effectiveness of the interphase transformer.

A calibration of the flux in the interphase is shown on Fig. 10b, where the vertical distance between the horizontal traces indicates that the total number of lines of flux for 2 cm. is 15,340,000. The flux density is $\approx 80,000$ lines per square inch (core area ≈ 190 square inches; $B \approx 12,500$ gauss).

Figures 11-15 show the I. P. T. "Flux" for various conditions. Each figure has its own explanation.

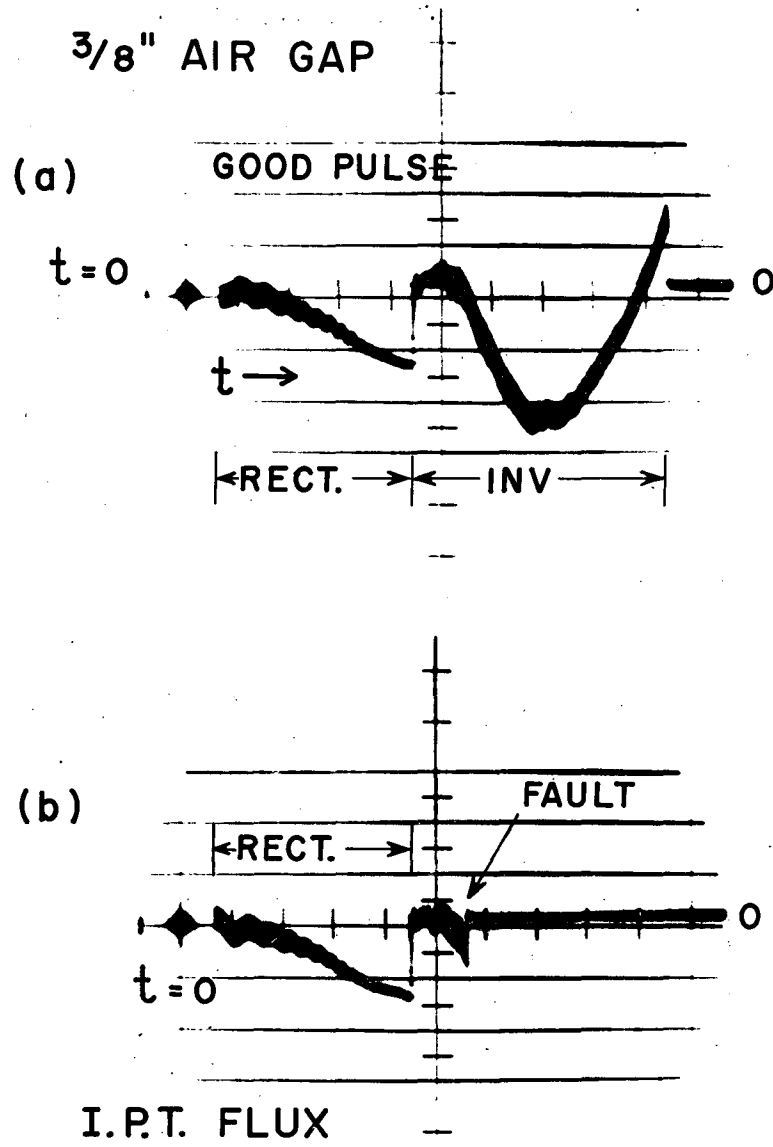

MU-8005

Figure 9

3/4" AIR GAP ON I.P.T.

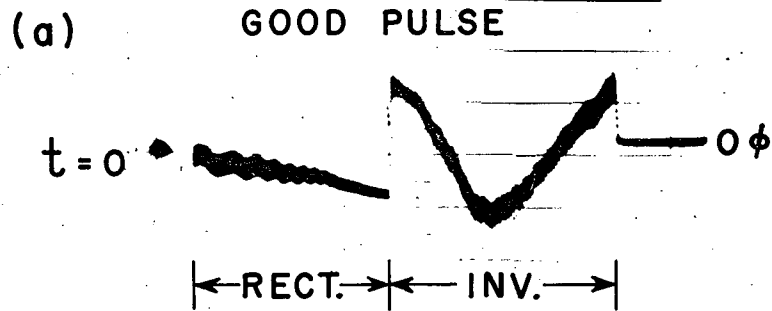

CALIBRATION

(b) $\phi = 15.34 \times 10^6$ LINES _____
 $B = \frac{15.34 \times 10^6}{190 \text{ in}^2} \approx 80,000 \text{ LINES/O"}$
 $\approx 12,500 \text{ GAUSS}$

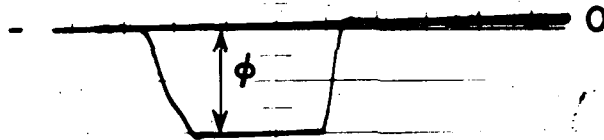

I. P.T. "FLUX"

MU-8006

Figure 10

3/4" AIR GAP ON I.P.T.
(a) SATURATION GOOD
DURING INVERSION
RECTIFICATION

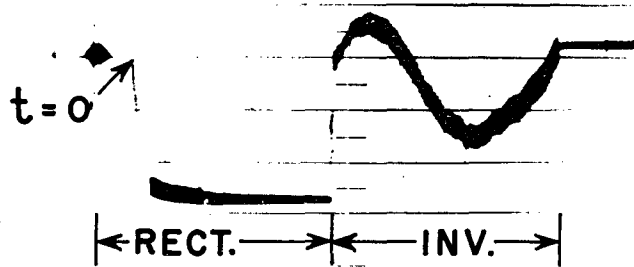

(b) SAME AS ABOVE

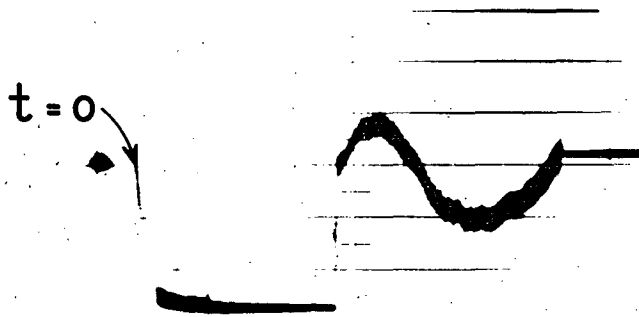

I.P.T. "FLUX"

MU-8007

Figure 11

3/4" AIR GAP

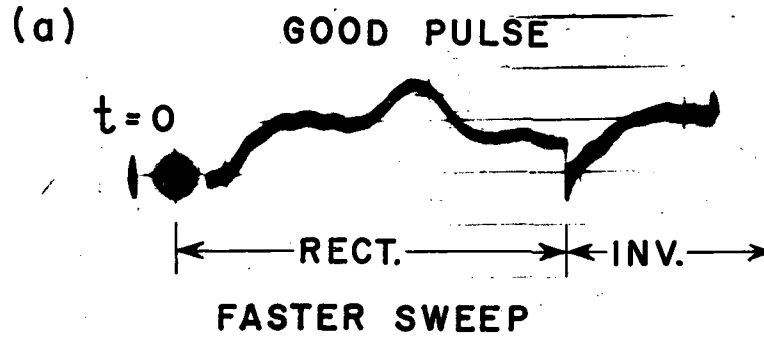

(b) CALIBRATION

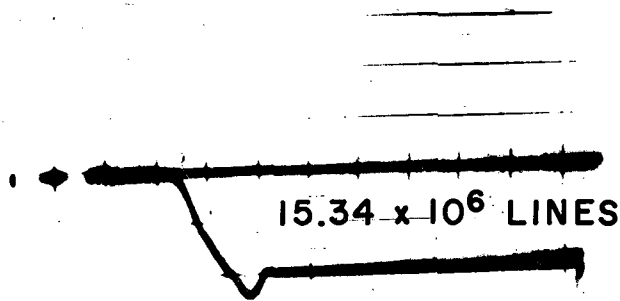

I.P.T. "FLUX"

MU-8008

Figure 12

(a) MINOR SHIFTS OF CURRENT

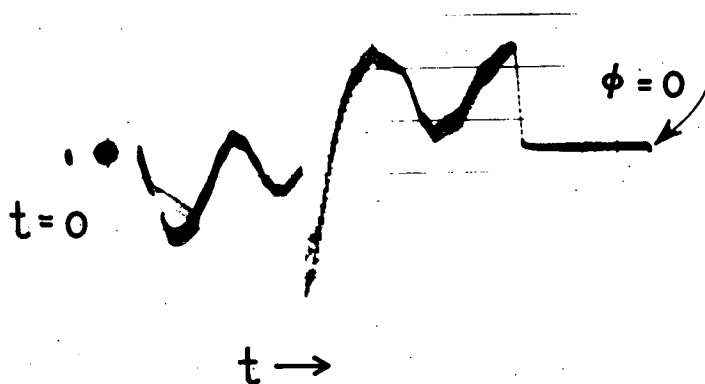

(b) LARGER SHIFTS CAUSING SATURATION

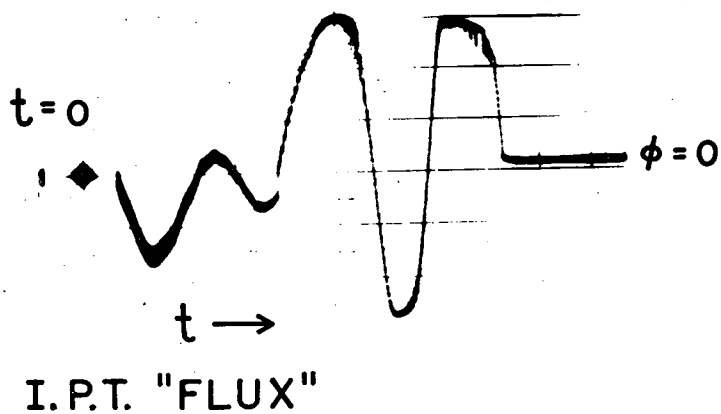

MU-8009

Figure 13

**3/4" AIR GAP A FORCED CURRENT
UNBALANCE DURING RECTIFICATION
WITH RECOVERY DURING INVER-
SION. A.C. CROSS-COMPENSATION.**

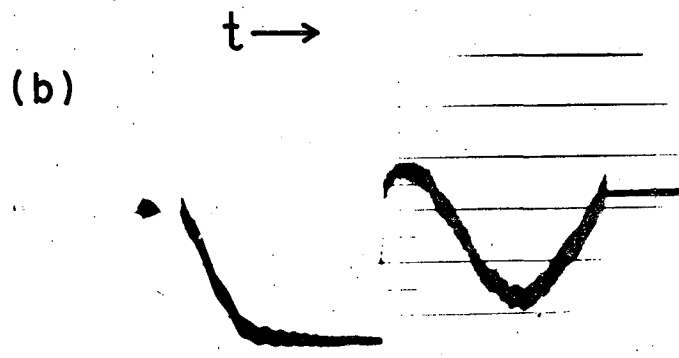
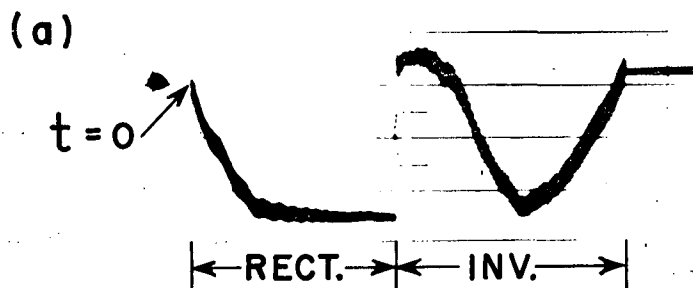

I.P.T. "FLUX"

MU-8010

Figure 14

ϕ SATURATION; $L \approx 0$ 3/4" GAP

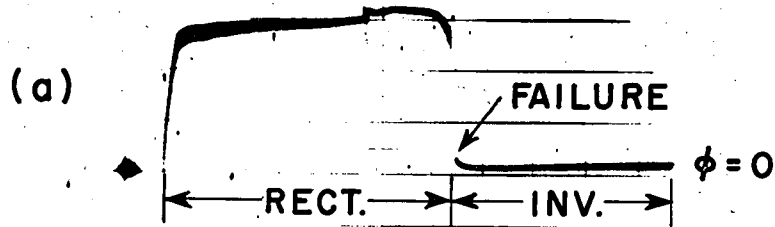

VERY LARGE UNBALANCE I DURING RECTIFICATION WILL CAUSE FAULTS AT INVERSION.

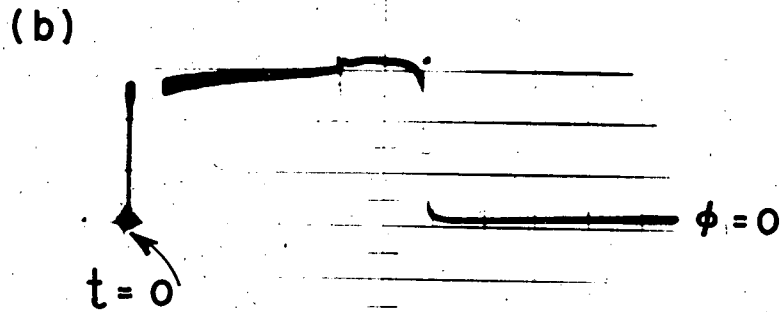

I. P. T. "FLUX"

MU-8011

Figure 15

IV. THE ANALOGUE OF THE INTERPHASE TRANSFORMER

In order to determine experimentally the fundamental effects of the interphase transformer, it was decided to use an analogue of the interphase transformer. The use of an analogue made it possible to work with smaller components. Also, it was easier to control conditions and change parameters.

The interphase transformer can be considered as an autotransformer with an air gap in its main magnet circuit. It can also be compared to an iron-cored choke coil. In addition, it operates somewhat like a saturable reactor.

Figure 16 shows two filter choke coils that are partially dismantled. (The keepers across the "E" core are discarded.) The remaining portions are placed together so that the E's coincide. With the polarity of the coils as shown, this represents an interphase transformer.

Equation (1) gives the voltage of a three-phase double-wye rectifier system using an interphase transformer. In Fig. 16 the dc component is represented by the batteries, and the $0.057 \cos 6\omega t$ is represented by the ac generator $Ae^{j\omega t}$. The rectifier elements are used for control purposes and also to parallel more closely the situation of the actual interphase transformer where dc current can flow only in the direction of the two outside terminals to the center terminal. The batteries also permit operation at any desired point of the double magnetization curve of Fig. 2b. This corresponds to a dc current unbalance between the actual parallel inverters.

The voltage represented by equation (1) is for the condition that the commutation angle is equal to zero. However, if the commutation angle is not zero, the resultant voltage waves applied across the interphase transformer will not be a triangular-shaped wave as shown in Region I of Fig. 1b, but some other shape, depending upon the applied voltages.

To deal with complex wave forms in the analogue of the interphase would only complicate matters, as can be seen in Fig. 17. This figure indicates that any wave shape that could be predicted and equated into its equivalent sine and cosine components (or complex form) could be represented on the analogue interphase transformer.

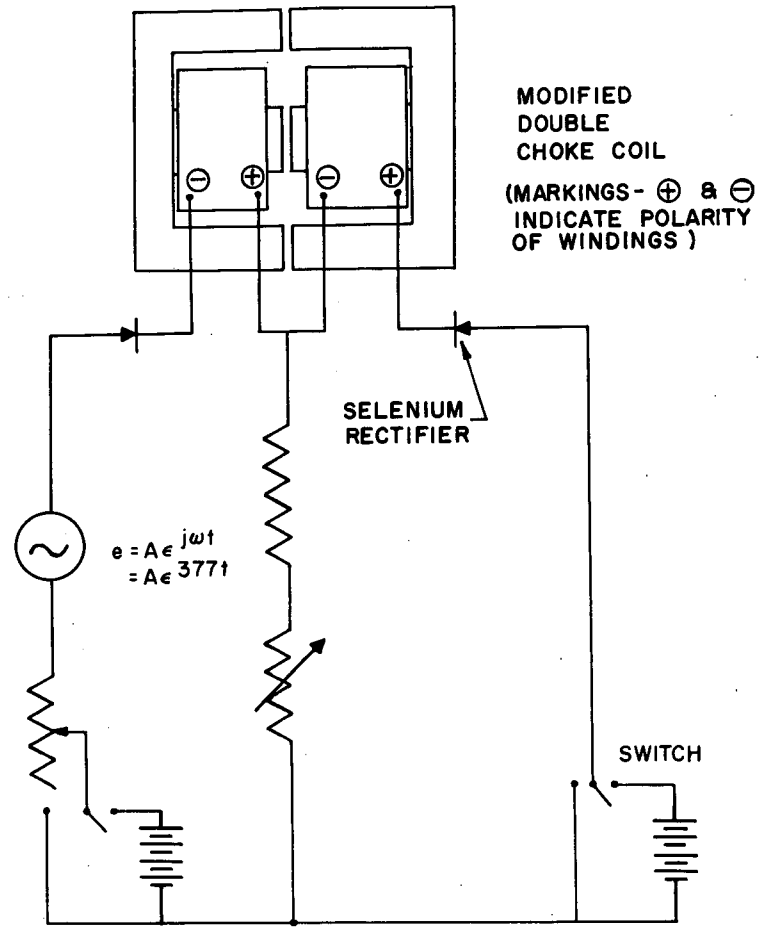

Fig. 16--- I.P.T. Analogue

MU-7986

Figure 16

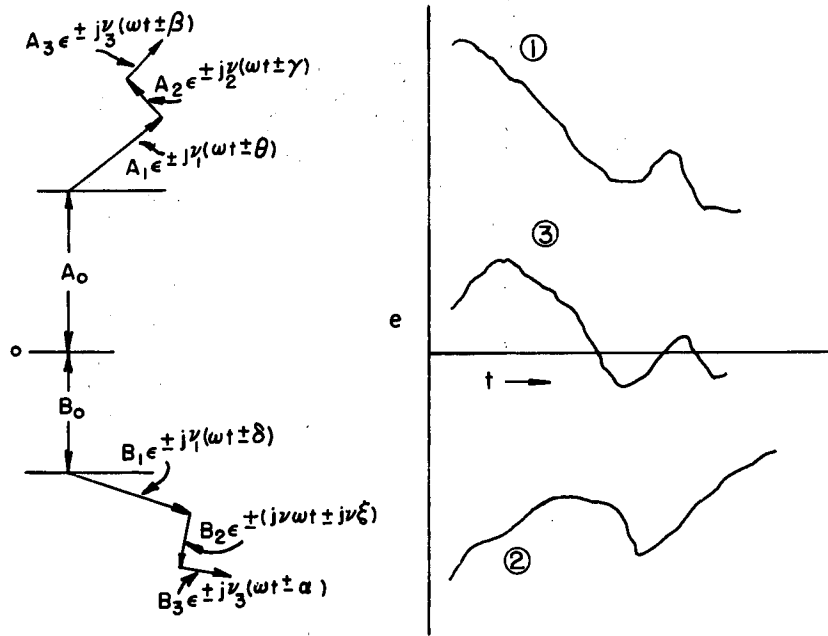
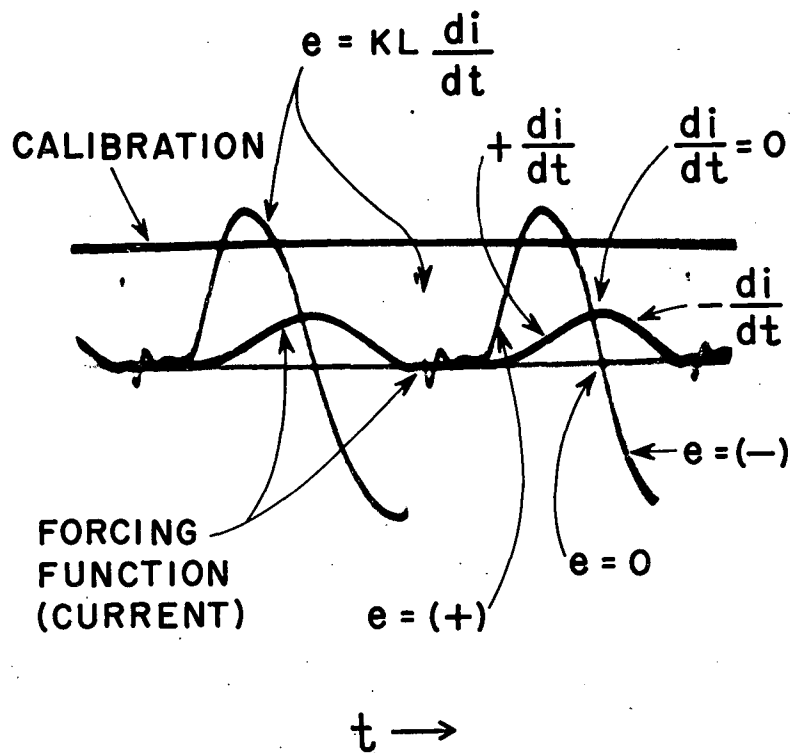

Fig. 17--- Comparison of Rotating Vectors
vs.
Complex Wave

MU-7987

Figure 17

ANALOGUE VOLTAGE AND CURRENT



MU-8012

Figure 18 a

ANALOGUE I.P.T. VOLTAGE & CURRENT

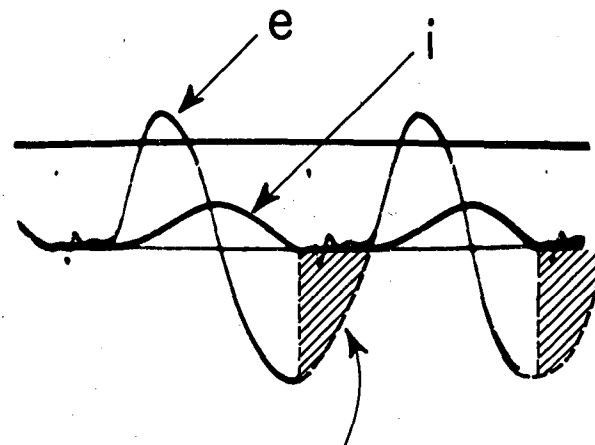

MU-8013

Figure 18 b

With use of the circuit and analogue interphase transformer of Fig. 16, the interrelation between current and voltage as shown in Fig. 18a can be seen. The wave marked $e = KLdi/dt$ represents the ripple voltage. The wave marked "forcing function" represents the net magnetizing current. Examination of the sign and magnitude of these current and voltage waves in this figure shows that they are directly related.

It should be noted that where the current wave di/dt is "clipped" by rectification, the voltage wave e rises abruptly with some oscillations. It represents the point of "saturation" in the interphase transformer due to current unbalance. The shaded area in Fig. 18b shows the voltage area "lost" due to this "saturation."

Figure 19 shows various forcing-current parameters; Fig. 20, the corresponding voltage parameters. In the latter, the white area just to the right of the perpendicular rise in the negative voltage represents one of the boundaries of the lost voltage, which is defined above.

Figure 21 shows the effect of changing the operating point on the magnetization curve of the interphase transformer analogue. This change in flux level is made by switching one of the batteries of Fig. 16 into the circuit. This corresponds to changing the dc current unbalance in the interphase transformer. (The portion of the curve with the sharp point below the dotted line in Fig. 21 is owing to energy stored in the magnetic field of the choke coil, which keeps the current flowing. If the forcing function were discontinued at point p, the function would decay exponentially, as shown in the curved dotted line.)

Since the induced voltage of the interphase transformer is zero at saturation, current unbalance between halves of the inverter begins to take place. As this unbalance becomes worse, because the "voltage required" to maintain current balance is greater than the voltage induced, the unbalance becomes complete if no other measures are taken to correct this condition.

Once the interphase transformer has saturated and the current is unbalanced, the effect of the interphase transformer is to oppose equal division of current. Figure 2a shows that effect. This is explained in greater detail later.

Refer to Fig. 2a and momentarily, for the sake of illustrating a point, disregard the ripple voltage of the inverters. Assume that there is

only a pure dc flat-topped wave across each side. If a small step function is imposed so that inverter voltage E_B is greater than inverter E_A , I_B becomes less than I_A . Now postulate that the total current I_A plus I_B is decreasing, and that dI_A/dt and dI_B/dt cannot become positive. Then

$$E_L = E_A + a = E_B + b.$$

Let $(K)dI_A/dt = -160$ amperes per unit time = a,

and $(K)dI_B/dt = -140$ amperes per unit time = b,

and $dI_{Total}/dt = -300$ amperes per unit time.

The net voltage difference between a and b due to rate of change of current is equal to $(-)(K)(20)$ volts. The differential effect is to add $-10K$ volts to E_A and $+10K$ volts to E_B . Thus E_B has a voltage component added to it, which causes the unbalance to be even greater. Since its voltage is now higher, it takes even less current. The interphase transformer becomes saturated if no quick means is available for balancing the voltage. Once this unbalance reaches a point where the interphase transformer is actually saturated, the only voltage which can exist across it is due to the IR drop. The passive character of the IR drop cannot force balancing.

How, then, is it possible for significant unbalance to exist at all? If the rectifiers are well paralleled to begin with and the load is equal in each circuit, unbalance can exist only if the interphase transformer cannot account for the instantaneous differences between the machines or halves. This naturally brings up the question of size of the interphase transformer.

It can be demonstrated that commutation angle, time of change-over from rectification to inversion, and wave shape must all be carefully considered in the determination of the proper interphase transformer. The results indicated from experiments on analogue should not be taken directly and applied without careful consideration of all factors. In an actual design all the important factors must be considered, lest there eventually be trouble. Certainly, in an interphase transformer, these elements must include the important harmonics and magnitudes of the unbalancing voltages.

Concerning the parallel operation of two or more frequency converters, C. M. Laffoon says:⁴

When care has not been exercised in the original designs, it has often proved impossible to arrange to divide the load in proper proportions between different sets. One set may take too much at a light load or vice versa, and even other times one set may take less load on all loads. All these troubles may be avoided by the application of known principles, but there have in the past been many instances in which factors requiring careful attention have been overlooked.

When synchronous units are employed to link two large systems, the slightest alteration in the relative frequencies of the two systems occasions enormous fluctuations of the load carried by the frequency converters, and unless the frequency converters are of large size compared to the systems which they connect, they will be pulled out of step if there is any slight change in the ratio of the frequencies of the two systems.

These statements were made in reference to rotary converters, but they apply equally well to electronic converters. In fact, if one considers the ignitrons only as switching devices, then they can be loosely compared to commutators. They are similar to a commutator, converting ac to dc. (The ordinary dc machine is not dc at all but actually an ac machine. A homopolar generator or motor is a true dc machine.)

The ignitron rectifier-inverter, however, has one distinct advantage over a commutator device. In order for a dc machine to invert, it would require that the direction of the field be changed so as to change its polarity; however, the rectifier-inverter combination needs only to have its firing time delayed or advanced for change in polarity.

CURRENT PARAMETERS ACROSS
("DOUBLE-CHOKE COIL"). CURRENT
IS THE INDEPENDENT VARIABLE
OR FORCING FUNCTION.

CALIBRATION

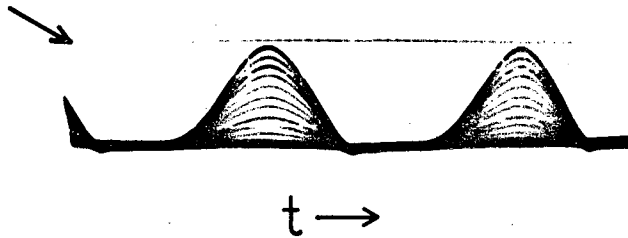

ANALOGUE

MU-8014

Figure 19

PARAMETERS OF VOLTAGE
CURVES CORRESPONDING
TO VARIOUS CURRENT
PARAMETERS.

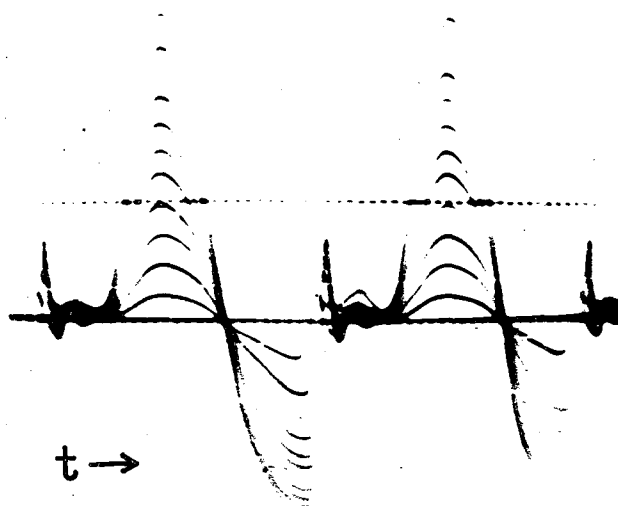

$$e = KL \frac{di}{dt}$$

ANALOGUE VOLTAGES

MU-8015

Figure 20

ANALOGUE CURRENT

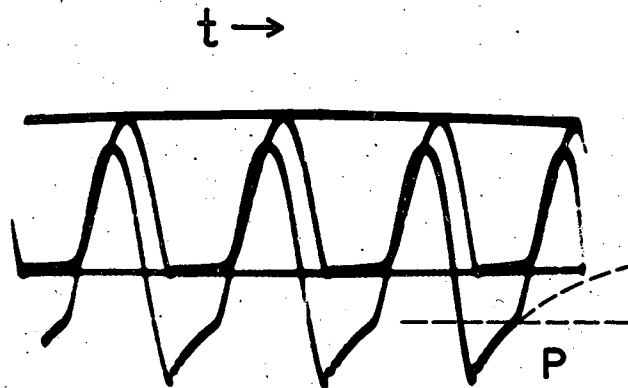

EFFECT OF BAISING OF FLUX ON CURRENT FLOW

MU-8016

Figure 21

V. EVALUATION OF EXPERIMENTAL RESULTS

The unsaturated analogue interphase transformer showed that it would compensate for detectable voltage differences appearing across it, whether those voltages were due to phase frequency or magnitude differences.

The unsaturated analogue interphase transformer also demonstrated that when a voltage ripple does appear across a power supply fed by it, that ripple component is the same in both voltages being applied to the interphase transformer.

The analogue interphase transformer illustrated that if it were saturated or unexcited, it could not balance the difference in the voltages applied to it, and that the ripple on its output contained components not necessarily common to both of the voltages applied to its terminals.

The general output voltage equation for an unsaturated interphase transformer is then:

$$e_{1PT} = \overbrace{\left[\pm i_1 \left(\frac{R_{1PT}}{2} \right) \pm i_1 \left(\frac{R_{1PT}}{2} \right) \right]}^a + \overbrace{\left[\pm (KL) \left(\pm \frac{di_1}{dt} \pm \frac{di_2}{dt} \right) \right]}^b + \underbrace{\left[(K\phi) \left[\pm \sum_{v=-\infty}^{v=+\infty} a_{1v} \epsilon^{jv\omega t} \pm \sum_{v=-\infty}^{v=+\infty} a_{2v} \epsilon^{jv(\omega t \pm \theta)} \right] \right]}^c \quad (6)$$

The quantity marked "a" is that portion of voltage due to ohmic drop. The quantity marked "b" is the resultant voltage induced by the difference in the rates of change of current of each half. The last term of the equation, "c", accounts for the differences between the voltages applied to the terminals of the interphase transformer. (The copious use of plus and minus signs is required to distinguish between rectification and inversion cycles.) Term "c" is by far the most important of all three terms of the equation of interphase output voltage. (A partial analytical treatment of this term can be found in Appendix C.)

Figure 1a is a representation of a synchronous three-phase double-why rectifier-inverter with an interphase transformer.

The curves of Fig. 1b show the individual rectifier or inverter output voltages for various firing angles and commutation angles (Regions I-IV).

Figure 1c illustrates how the shape and magnitude of the instantaneous difference voltages vary for the separate regions. Region I shows a triangular-shaped wave, which is the instantaneous voltage difference between the solid line and broken line ripple voltages of Fig. 1b, Region I. This is the case where the commutation angle is equal to zero for rectification. Region II of this same figure shows a periodic trapezoidal-shaped figure which has a slightly larger area than Region I. Region III has a different shape from Region I because of the commutation angle of 30° . But even if the angle of commutation were somewhat larger during rectification, there would be only a small order of difference in the interphase output voltage.

Consider Region III, the change-over interval from rectification to inversion. It shows that there is an astonishingly large voltage difference for an interval of about one-half cycle. The average voltage of Region III, change-over, is more than double the value of that in Region I.

Region IV shows the greater flux requirements during inversion operation.

If an interphase transformer is too small, and saturates while trying to provide the flux required for inducing balancing voltages, it can require magnetizing current of such a large magnitude that the magnetizing current itself is enough to cause unbalance of load division between the parallel inverters. This situation is similar to that of the very large surges of magnetizing current that can be drawn in first energizing an ordinary power transformer, even though the transformer secondary is open-circuited. In this case, the iron is already well saturated, and the change in flux required is in the direction of even greater saturation; thus the magnetizing current in attempting to produce that required flux change becomes fantastically large because of the shape of the magnetization curve. Many times, the instantaneous-overload trip relays operate to open the circuit. Operators are always warned to take ammeters out of the circuit when first exciting a transformer.

In Fig. 22 postulate that $I_T = I_a + I_b$. Let I_a momentarily become larger than I_b . The rates of change, $L di/dt$, equal the induced interphase

voltage. One-half the induced voltage of the interphase transformer is added to V_{Ta} and subtracted from V_{Tb} . As a result ΔV_a becomes smaller, which reduces I_a , and, conversely, ΔV_b becomes larger to increase I_b .

Margin-angle change is shown in the same figure. Its effect is to lower the inverter voltage by advancing the firing angle as an inverter. This effect is an average one because the outputs are added. (The actual circuits are such that the margin-angle phase-shifting circuits are in series, so that the average value is the same for both halves of the inverter.)

General voltage equations for electrical machinery are:

$$E = K_1 N \frac{d\phi}{dt} \text{ volts,} \quad (7)$$

$$E_{ave} = K_2 N f \phi_{max} \text{ volts.} \quad (8)$$

If the average voltage to be supplied by the interphase transformer is determined graphically or by other suitable means, one can find a measure of the maximum required flux. A ratio can be established between the maximum voltage and the average voltage. This permits the determination of the maximum flux.

A graphical determination is found from Fig. 1 c. The ratios of these various voltages are:

$$(a) \frac{E_{ave} \text{ (Region IV)}}{E_{ave} \text{ (Region I)}} = \frac{1.75}{0.55} = 3.2,$$

$$(b) \text{ the ratio of } \frac{\phi_{max} \text{ (Region IV)}}{\phi_{ave} \text{ (Region IV)}} = \frac{3}{1.75} = 1.71 \quad (9)$$

$$\text{while the ratio of } \frac{\phi_{max} \text{ (Region I)}}{\phi_{ave} \text{ (Region I)}} = \frac{1.1}{0.55} = 2.0.$$

Figure 23 shows rectifier-inverter wave forms for the case where the voltage e_B leads e_A by 30° and the commutation angle has a finite value. Figure 24 illustrates wave forms when e_B lags e_A by 30° . Figure 25 compares rectifier voltages when they are (a) standard, or (b) and (c) displaced by plus or minus 30° . (Commutation angle is zero in this figure.)

From these data one can find the required core--copper, air gap, etc. An outline for an interphase transformer design is shown in Appendix A.

A pertinent factor not discussed here is the economic feasibility of building the interphase transformer as large as is required.

A more precise and elegant way to determine the interphase transformer requirements is to make a Fourier analysis of the different voltages appearing across it. The Appendix offers some preliminary steps for such an analysis, as required to evaluate an interphase transformer for a pair of three-phase half-wave electronic converters.

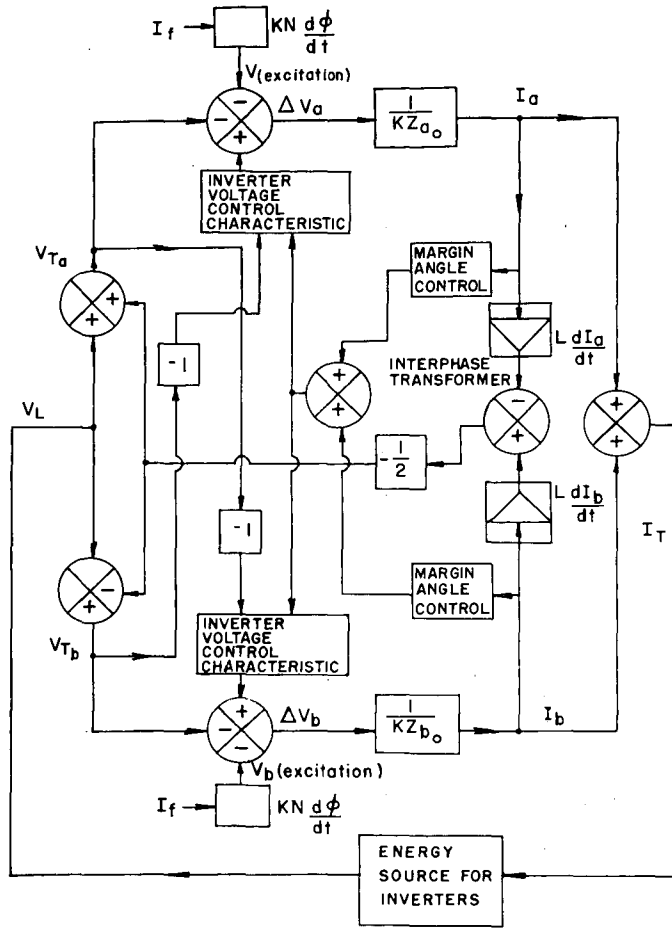
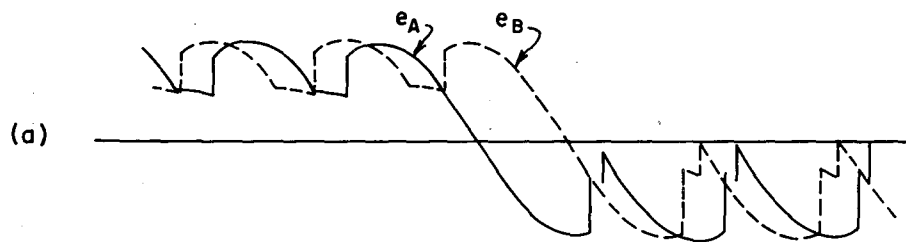

Fig. 22---Block Diagram of Parallel Inverters Having Negative Feedback, Common Margin Angle Control, and an Interphase Transformer

MU-7988

Figure 22

WAVE FORMS FOR RECTIFIER INVERTER
(e_B LEADS e_A BY 30°)



VOLTAGE ACROSS I.P.T.

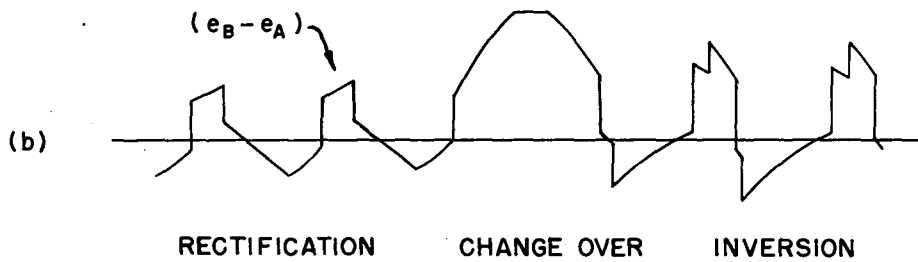

MU-7989

Figure 23

WAVE FORMS FOR RECTIFIER - INVERTER

(e_B LAGS e_A BY 30°)

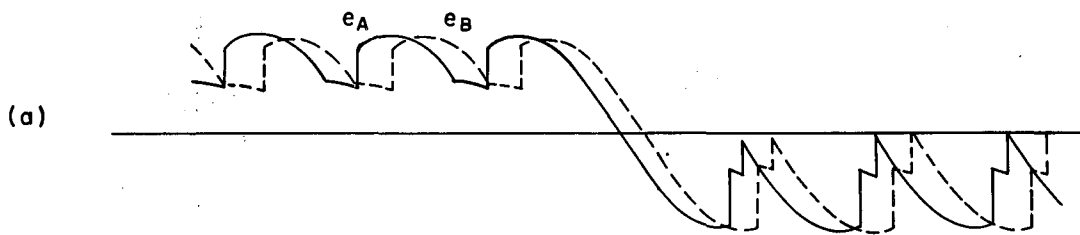

VOLTAGE ACROSS I. P. T.

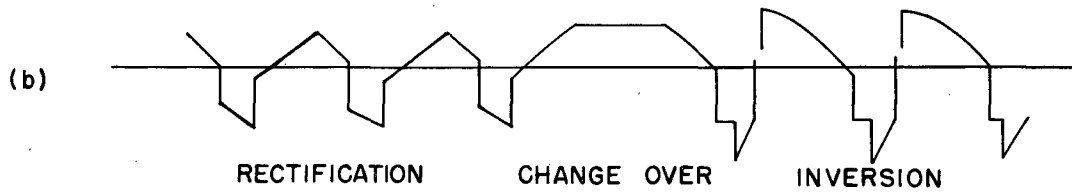

MU-7990

Figure 24

RECTIFIER WAVE FORMS ($\mu = 0^\circ$)

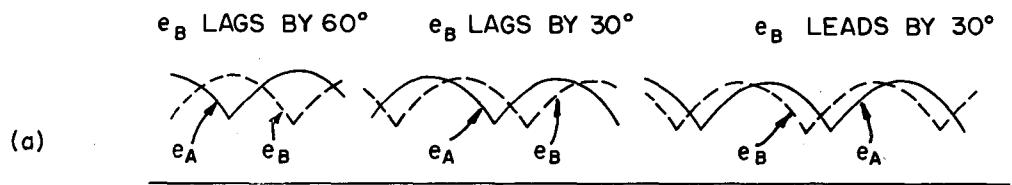

VOLTAGE ACROSS I.P.T.

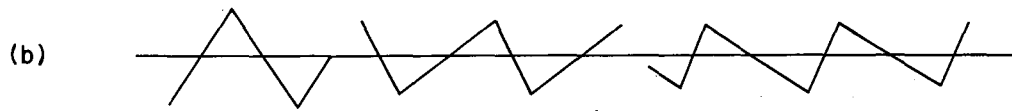

MU-7991

Figure 25

VI. CONCLUSIONS

If an interphase transformer is amply designed so that it never saturates and can at all times balance all instantaneous differential voltages appearing across it, it will have an equalizing effect on the division of current between parallel inverters.

If an interphase transformer is saturated because of an unbalance of current, it will oppose equal division of currents between parallel inverters.

When inverter output voltages are controlled by impulses provided by peaking transformers, which in turn are excited by the inverter output voltages, it is then necessary to feed an error difference signal to the firing impulses in such a manner as to increase the magnitude of the negative inverter voltage of the unit carrying the greater load and to decrease the negative magnitude voltage of the inverter carrying the less load. This establishes a state of equilibrium in which the differential excursions from the mean are controlled by the over-all response of the systems.

When equal division of load between synchronous parallel inverters is controlled by means of negative feedback in firing circuits, an interphase of smaller size can give satisfactory results.

Parallel operation of variable asynchronous parallel inverters under transient conditions has not yet (to the writer's knowledge) been successfully accomplished. However, it is surely a solvable problem. As with synchronous parallel inverters, all voltage differences must be balanced, either by interphase transformers of sufficient size or by very fast, accurate control of firing angles of the electronic components. The correcting compensation must take place within fractional parts of a cycle. A predictor regulator operating at a considerably higher frequency is one feasible approach to the solution.

Another factor governing the division of load in parallel inverters feeding into an interphase transformer is the selection of the optimum time for making the "change-over." (Figures 1 c, 23, and 24 show the variation in the voltage and flux requirements.)

When the interphase transformer is of sufficient size, it acts as an autotransformer compensating for electromotive forces due to ripple voltage and rate of change of current differences.

The economic limit to the size of the interphase transformer should be the differential cost of the added size of the interphase versus the cost of precise voltage- and firing-control equipment.

When paralleling inverters, it is necessary to have either a supersensitive voltage control or an absolutely insensitive voltage control. No medium values of response can be tolerated; the response must be either well below the range of the voltage-change time constants or well above the voltage-change response.

A vastly different set of voltage conditions is imposed on an interphase transformer when it is used between parallel inverters than when it is used between parallel rectifiers. Thus the requirements for interphase transformers must be carefully chosen for the specific application.

Commutation angle has a bearing on the size of interphase transformers, whether the interphase transformer is used between parallel inverters or parallel rectifiers, synchronous or asynchronous.

ACKNOWLEDGMENTS

I wish to acknowledge the valuable suggestions and assistance given to me by Dr. Otto J. M. Smith and the staff of the Electrical Engineering Division of the University of California; and the aid and encouragement of Mr. George M. Farly, of the Electronics Engineering Department of the Radiation Laboratory, with whom I have worked closely on the Bevatron Magnet Power Supply.

I also wish to especially thank Mr. James S. Norton, Head of the Electronics Engineering Department of the University of California Radiation Laboratory, for his permission to engage in the scholastic activities that have fostered this investigation.

APPENDIXES

A. OUTLINE FOR A SAMPLE DESIGN OF AN INTERPHASE TRANSFORMER

1. Determine the average, peak, and rms voltages, either graphically or analytically, for the chief harmonics.

2. Substitute the E_{average} value in the equation

$$E_{\text{ave}} = 4n\phi_{\text{max}} f \times 10^{-8}$$

and find the $\phi_{\text{max}} = \frac{E_{\text{ave}} \times 10^8}{4nf}$ lines;

n = number of turns in series

ϕ_{max} = maximum value of flux

f = number of complete cycles per second

4 = the number of times that each complete turn cuts the maximum flux per cycle.

For a sine wave, the $E_{\text{max}} = \frac{\pi}{2} E_{\text{ave}} = 2\pi n\phi_{\text{max}} f 10^{-8}$ volts;

$$E_{\text{rms}} = \frac{E_{\text{max}}}{(2)^{1/2}} = 4.44n\phi_{\text{max}} f 10^{-8} \text{ volts.}$$

Assuming that the peak value of the voltage required is determined, then allowing a maximum flux density--say, 80,000 lines per square inch-- one can find the maximum flux on a per unit basis.

$$\phi_{\text{max}} = \frac{E_{(\text{max})} \times 10^8}{nf} = (B_{\text{max}}) (\text{core area}).$$

$$\text{Required core area} = \frac{E_{\text{max}} 10^8}{nf 8 \times 10^4} = \frac{0.125 E_{\text{max}} 10^4}{nf}$$

(sq. in.)
per turn per cycle/sec

Knowing the above, it must next be decided how much air gap is needed to prevent the core from saturating at the maximum value of unbalance current that is to be allowed between the two halves of the inverter. The rest of the design is like that for a conventional transformer.

B. INTERPHASE TRANSFORMERS FOR PARALLEL INVERTERS

In Fig. 26 are curves from which we may determine equations of voltage across an interphase transformer.

General equation for the voltage across an interphase transformer that is in a 3-phase double-wye circuit:

$$e_{ipt} = f(t) = \sum_{v=-\infty}^{v=+\infty} a_v \epsilon^{jv\omega t};$$

let α = firing angle and μ = commutation angle.

$$a_v = \left[\frac{\omega}{2\pi} \left[\int_{\left(1 + \frac{\alpha}{360}\right) \frac{\pi}{6\omega}}^{\left(1 + \frac{\alpha + \mu}{360}\right) \frac{\pi}{6\omega}} \left[\left(\frac{e_1 + e_2}{2} \right) - e_3 \right] \epsilon^{-jv\omega t} dt + \int_{\left(1 + \frac{\alpha + \mu}{360}\right) \frac{\pi}{6\omega}}^{\left(1 + \frac{\alpha + \mu}{360}\right) \frac{\pi}{2\omega}} (e_1 - e_3) \epsilon^{-jv\omega t} dt + \right. \right.$$

$$\left. \int_{\left(1 + \frac{\alpha}{360}\right) \frac{\pi}{2\omega}}^{\frac{\pi}{2\omega} \left(1 + \frac{\alpha + \mu}{360}\right)} \left[\left(\frac{e_4 + e_3}{2} \right) - e_1 \right] \epsilon^{-jv\omega t} dt + \int_{\left(1 + \frac{\alpha + \mu}{360}\right) \frac{\pi}{2\omega}}^{\left(1 + \frac{\alpha + \mu}{360}\right) \frac{5}{6} \frac{\pi}{\omega}} (e_4 - e_1) \epsilon^{-jv\omega t} dt \right],$$

from Fig. 26:

$$e_1 = \sin \left(\omega t + \frac{\pi}{6} \right) = 0.867 \sin \omega t + 0.5 \cos \omega t$$

$$e_2 = \sin \left(\omega t + \frac{5}{6} \pi \right) = -0.867 \sin \omega t + 0.5 \cos \omega t$$

$$e_3 = \sin \left(\omega t + \frac{\pi}{2} \right) = \cos \omega t$$

$$e_4 = \sin \left(\omega t - \frac{\pi}{6} \right) = 0.867 \sin \omega t - 0.5 \cos \omega t$$

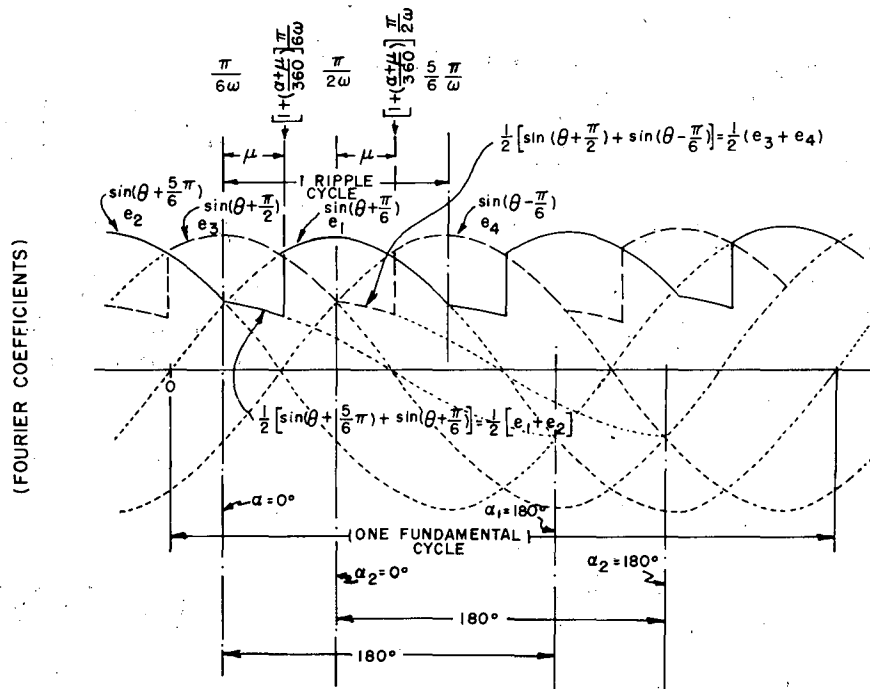

Fig. 26---Curves for Determining Equations of Voltage Across an Interphase Transformer (3 Phase Half-Wave Double-Wye)

MU-7992

Figure 26

$$\left(\frac{e_1 + e_2}{2}\right) = + 0.5 \cos \omega t; \quad \left[\left(\frac{e_1 + e_2}{2}\right) - e_3\right] = - 0.5 \cos \omega t$$

$$(e_1 - e_3) = \sin \left(\omega t - \frac{\pi}{6}\right); \quad \left[\left(\frac{e_4 + e_3}{2}\right) - e_1\right] = - 0.5 \sin \left(\omega t + \frac{\pi}{6}\right)$$

$$(e_4 - e_1) = - \cos \omega t.$$

$$a_v = \frac{\omega}{2\pi} \left[\underbrace{\left[\begin{array}{l} \left(1 + \frac{\alpha + \mu}{360}\right) \frac{\pi}{6\omega} \\ -0.5 \left[\frac{\epsilon^{j\omega t} + \epsilon^{-j\omega t}}{2} \right] \\ \left(1 + \frac{\alpha}{360}\right) \frac{\pi}{6\omega} \end{array} \right] \epsilon^{-j\nu\omega t} dt}_{\text{"a"}} + \underbrace{\left[\begin{array}{l} \left(1 + \frac{\alpha + \mu}{360}\right) \frac{\pi}{2\omega} \\ \left[\frac{\epsilon^{j(\omega t - \frac{\pi}{6})} - \epsilon^{-j(\omega t - \frac{\pi}{6})}}{2j} \right] \\ \left(1 + \frac{\alpha + \mu}{360}\right) \frac{\pi}{6\omega} \end{array} \right] \epsilon^{-j\nu\omega t} dt}_{\text{"b"}} + \dots \right]$$

$$\left[\underbrace{\left[\begin{array}{l} \left(1 + \frac{\alpha + \mu}{360}\right) \frac{\pi}{2\omega} \\ -0.5 \left[\frac{\epsilon^{j(\omega t + \frac{\pi}{6})} - \epsilon^{-j(\omega t + \frac{\pi}{6})}}{2j} \right] \\ \left(1 + \frac{\alpha}{360}\right) \frac{\pi}{2\omega} \end{array} \right] \epsilon^{-j\nu\omega t} dt}_{\text{"c"}} + \underbrace{\left[\begin{array}{l} \left(1 + \frac{\alpha + \mu}{360}\right) \frac{5}{6} \frac{\pi}{\omega} \\ (-1) \left[\frac{\epsilon^{j\omega t} + \epsilon^{-j\omega t}}{2} \right] \\ \left(1 + \frac{\alpha + \mu}{360}\right) \frac{\pi}{2\omega} \end{array} \right] \epsilon^{-j\nu\omega t} dt}_{\text{"d"}} \right]$$

$$\omega = 2\pi f;$$

let $\alpha = 120^\circ$

and $\mu = 30^\circ$

then for portion "a" only:

$$a_{v_{\text{"a"}}} = \frac{\omega}{2\pi} \int \left(\begin{array}{l} \left(1 + \frac{15}{36}\right) \frac{\pi}{6\omega} \\ -0.5 \left(\frac{\epsilon^{j\omega t(1-\nu)} + \epsilon^{-j\omega t(1+\nu)}}{2} \right) \\ \left(1 + \frac{1}{3}\right) \frac{\pi}{6\omega} \end{array} \right) dt =$$

$$\frac{\omega}{2\pi} \frac{(-0.5)}{2} \left[\frac{\epsilon^{j\omega t(1-\nu)}}{j\omega(1-\nu)} - \frac{\epsilon^{-j\omega t(1+\nu)}}{j\omega(1+\nu)} \right] \left(\frac{51}{36} \right) \left(\frac{\pi}{6\omega} \right) =$$

$$\left(\frac{4}{3} \right) \left(\frac{\pi}{6\omega} \right)$$

$$- \frac{1}{8\pi} \left[\frac{\epsilon^{j(1-\nu) \frac{51\pi}{216}}}{j(1-\nu)} - \frac{\epsilon^{-j(1+\nu) \frac{51\pi}{216}}}{j(1+\nu)} - \frac{\epsilon^{j(1-\nu) \frac{4\pi}{18}}}{j(1-\nu)} + \frac{\epsilon^{-j(1+\nu) \frac{4\pi}{18}}}{j(1+\nu)} \right];$$

let $\theta_1 = \frac{51\pi}{216}$; and $\theta_2 = \frac{2\pi}{9}$:

$$a_{v_a} = - \frac{1}{8\pi} \left[\frac{\epsilon^{j\theta_1} \epsilon^{-j\nu\theta_1}}{j(1-\nu)} - \frac{\epsilon^{-j\theta_1} \epsilon^{-j\nu\theta_1}}{j(1+\nu)} - \frac{\epsilon^{j\theta_2} \epsilon^{-j\nu\theta_2}}{j(1-\nu)} + \frac{\epsilon^{-j\theta_2} \epsilon^{-j\nu\theta_2}}{j(1+\nu)} \right] =$$

rationalizing:

$$- \frac{1}{8\pi} \left[\frac{\begin{matrix} j(1-\nu)\theta_1 & j(1-\nu)\theta_1 & -j(1+\nu)\theta_1 & -j(1+\nu)\theta_1 & j(1-\nu)\theta_2 & j(1-\nu)\theta_2 & -j(1+\nu)\theta_2 & -j(1+\nu)\theta_2 \\ \epsilon & +\nu\epsilon & -\epsilon & +\nu\epsilon & -\epsilon & -\nu\epsilon & +\epsilon & -\nu\epsilon \end{matrix}}{j(1-\nu^2)} \right]$$

collecting terms:

$$= - \frac{1}{8\pi} \left[\frac{\epsilon^{-j\nu\theta_1}}{j(1-\nu^2)} \left[\epsilon^{j\theta_1} - \epsilon^{-j\theta_1} + \nu \left(\epsilon^{j\theta_1} + \epsilon^{-j\theta_1} \right) \right] - \frac{\epsilon^{-j\nu\theta_2}}{j(1-\nu^2)} \left[\epsilon^{j\theta_2} - \epsilon^{-j\theta_2} + \nu \left(\epsilon^{j\theta_2} + \epsilon^{-j\theta_2} \right) \right] \right]$$

substituting for θ_1 and θ_2 :

$$a_{v_a} = - \frac{1}{4\pi(1-\nu^2)} \left[\left(\epsilon^{-j\nu \frac{51\pi}{216}} \right) \left[\sin \left(\frac{51\pi}{216} \right) - j\nu \cos \left(\frac{51\pi}{216} \right) \right] - \right.$$

$$\left. \left(\epsilon^{-j\nu \frac{2\pi}{9}} \right) \left[\sin \left(\frac{2\pi}{9} \right) - j\nu \cos \left(\frac{2\pi}{9} \right) \right] \right]$$

Coefficients a_{v_b} , a_{v_c} and a_{v_d} are determined in the same manner.

The final voltage (general equation):

$$e_{ipt} = \sum_{v=-\infty}^{v=+\infty} (a_{v_a} + a_{v_b} + a_{v_c} + a_{v_d}) e^{jv\omega t}$$

C. INTERPHASE TRANSFORMERS FOR PARALLEL INVERTERS

Required: To evaluate the periodic function shown below by a complex Fourier series.

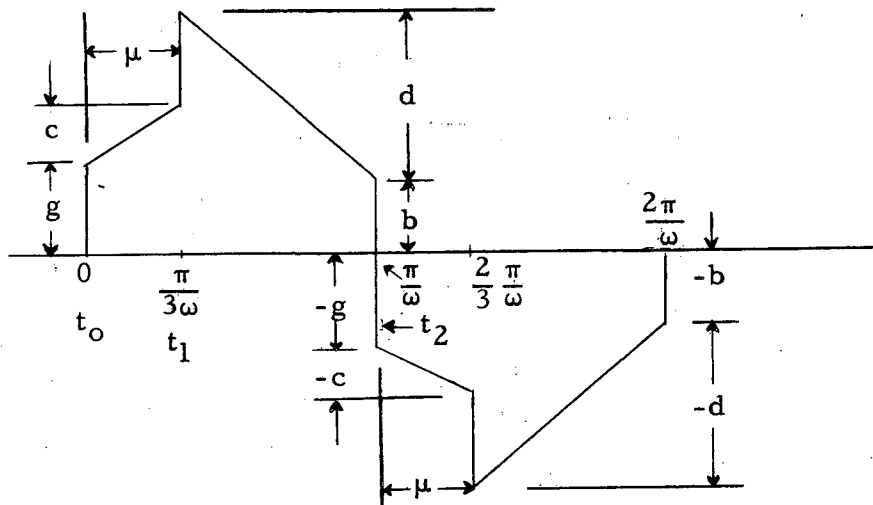

Let $\mu = 60^\circ$ (overlap or commutation angle, or $= \frac{\pi}{3\omega}$).

The exponential form of the Fourier Series:

$$f(t) = \sum_{v=-\infty}^{v=+\infty} a_v e^{jv\omega t}$$

$$a_v = \frac{\omega}{2\pi} \int_0^{2\pi} f(t) e^{-jv\omega t} dt$$

In the periodic function drawn above, there are 4 distinct sections. Each half, however, is symmetrical, thus the labor can be reduced by one half.

To find the equations in terms of the angle " μ ",

$$\begin{cases} n - x \left[\frac{\mu}{360} \frac{2\pi}{\omega} \right] = 1, \\ n - x \left(\frac{\pi}{\omega} \right) = 0, \end{cases}$$

$$x \frac{\pi}{\omega} - \frac{x \mu \pi}{180 \omega} = 1,$$

$$x = \frac{180 \omega}{\pi(180 - \mu)} ; n = \left(\frac{180}{180 - \mu} \right).$$

If $\mu = 60^\circ$

$$\left[\omega = 2 \pi f ; \text{ where } f \text{ is the fundamental} \right],$$

$$x = \frac{180 \omega}{\pi(180 - 60)} = \frac{3}{2} \frac{\pi}{\omega},$$

$$n = \frac{180}{180 - 60} = \frac{3}{2},$$

Therefore

$$k = \left[\frac{3}{2} - \frac{3}{2} \frac{\omega t}{\pi} \right].$$

$$f_1(t) = \left[g + c \left(\frac{3\omega t}{\pi} \right) \right]; \quad 0 < t < \frac{\pi}{3\omega} \quad (1)$$

$$f_2(t) = \left[b + d \left(\frac{3}{2} - \frac{3\omega t}{2\pi} \right) \right]; \quad \frac{\pi}{3\omega} < t < \frac{\pi}{\omega} \quad (2)$$

$$f_3(t) = \left[-g - c \left(\frac{3\omega t}{\pi} \right) \right]; \quad \frac{\pi}{\omega} < t < \frac{2\pi}{3\omega} \quad (3)$$

$$f_4(t) = \left[-b - d \left(\frac{3}{2} - \frac{3\omega t}{2\pi} \right) \right]; \quad \frac{2}{3} \frac{\pi}{\omega} < t < 2\pi \quad (4)$$

$$a_{1\nu} = \frac{\omega}{2\pi} \int_0^{\frac{\pi}{3\omega}} \left(g + c \frac{3\omega t}{\pi} \right) \epsilon^{-j\nu\omega t} dt =$$

$$\frac{\omega}{2\pi} \int_0^{\frac{\pi}{3\omega}} g \epsilon^{-j\nu\omega t} dt + c \frac{3\omega}{\pi} \int_0^{\frac{\pi}{3\omega}} t \epsilon^{-j\nu\omega t} dt =$$

$$\frac{\omega}{2\pi} \left[\frac{g \epsilon^{-j\nu\omega t}}{-j\nu\omega} \right]_0^{\frac{\pi}{3\omega}} + c \frac{3\omega}{\pi} \left[\frac{t \epsilon^{-j\nu\omega t}}{-j\nu\omega} - \frac{\epsilon^{-j\nu\omega t}}{-j\nu\omega} \right]_0^{\frac{\pi}{3\omega}}$$

$$a_{1_v} = -\frac{1}{jv2\pi} \left[\epsilon^{-jv\frac{\pi}{3}} \left(g + c - c \frac{3\omega}{\pi} \right) - g + c \frac{3\omega}{\pi} \right] \quad (1')$$

Similarly

$$a_{3_v} = -\frac{1}{jv2\pi} \left[\epsilon^{-jv\frac{2}{3}\pi} \left(-g - c \left(2 + c \frac{3\omega}{\pi} \right) \right) - \epsilon^{-jv\pi} \left(-g - 3c + c \frac{3\omega}{\pi} \right) \right], \quad (3')$$

$$a_{2_v} = \frac{\omega}{2\pi} \int_{\frac{\pi}{3\omega}}^{\frac{\pi}{\omega}} \left(b + \frac{3}{2}d - \frac{3}{2}d \frac{\omega t}{\pi} \right) \epsilon^{-jv\omega t} dt =$$

$$-\frac{1}{jv2\pi} \left[\epsilon^{-jv\pi} \left(b + \frac{3}{2} \frac{\omega d}{\pi} \right) - \epsilon^{-jv\frac{\pi}{3}} \left(b + d + \frac{3}{2} \frac{\omega d}{\pi} \right) \right] \quad (2')$$

$$a_{4_v} = -\frac{1}{jv2\pi} \left[\epsilon^{-jv2\pi} \left(-b - \frac{3}{2} \frac{\omega d}{2\pi} \right) - \epsilon^{-jv\frac{2}{3}\pi} \left(-b - d - \frac{3}{2} \frac{\omega d}{2\pi} \right) \right] \quad (4')$$

Therefore the complete form for the complex Fourier Series:

$$f(t) = \sum_{v=-\infty}^{v=+\infty} -\frac{1}{jv2\pi} \left[\left(\epsilon^{-jv\frac{\pi}{3}} \right) \left[g + c \left(1 - \frac{3\omega}{\pi} \right) \right] - \left[g + c \frac{3\omega}{\pi} \right] \right] +$$

$$\left[\left(\epsilon^{-jv\pi} \right) \left(b + \frac{3}{2} \frac{\omega d}{\pi} \right) - \left(\epsilon^{-jv\frac{\pi}{3}} \right) \left(b + d \left(1 + \frac{3\omega}{2\pi} \right) \right) \right] +$$

$$\left[\left(\epsilon^{-jv\frac{2}{3}\pi} \right) \left(-g - c \left(2 - \frac{3\omega}{\pi} \right) \right) - \left(\epsilon^{-jv\pi} \right) \left(-g - c \left(3 - \frac{3\omega}{\pi} \right) \right) \right] +$$

$$\left[\left(\epsilon^{-jv2\pi} \right) \left(-b - \frac{3}{2} \cdot \frac{\omega}{2\pi} d \right) - \left(\epsilon^{-jv\frac{2}{3}\pi} \right) \left(-b - d \left(1 + \frac{3}{2} \cdot \frac{\omega}{2\pi} \right) \right) \right] \epsilon^{jv\omega t}.$$

REFERENCES

1. "Applied Electronics", Massachusetts Institute of Technology, Department of Electrical Engineering, Wiley, New York, 1954, p.330 - 377.
2. L. A. Rovelsky, A History of Grid-Controlled Inverters, E. E. 200-A Seminar Report, on file at the University of California Engineering Library.
3. E. Guillemin, Communication Networks, Wiley, New York, Vol. I., Section on Complex Wave Analysis, p. 380 ff.
4. Standard Handbook for Electrical Engineers, A. E. Knowlton, Editor-in-chief, McGraw-Hill, New York, 1941, 7th edition, Sec.7-343.
5. J. L. Boyer and C. R. Marcum, Ignitron Converters for High-Energy Particle Accelerators, Elec. Eng. 69, 871 (1950).
6. J. V. Kresser, The Bevatron Power Plant, Elec. Eng. 71, 338 (1952).