

# Lawrence Berkeley National Laboratory

## Recent Work

### Title

The Use of Redox Polymerization Electrodes in Lithium Batteries with Liquid Electrolytes

### Permalink

<https://escholarship.org/uc/item/8nt8v8ht>

### Authors

Doeff, M.M.

Visco, S.J.

Jonghe, L.C. De

### Publication Date

1991-03-01



# Lawrence Berkeley Laboratory

UNIVERSITY OF CALIFORNIA

## Materials & Chemical Sciences Division

Submitted to the Journal of the Electrochemical Society

### The Use of Redox Polymerization Electrodes in Lithium Batteries with Liquid Electrolytes

M.M. Doeff, S.J. Visco, and L.C. De Jonghe

March 1991



BLDG. 50 Library.

Copy 1

LBL-30466

#### **DISCLAIMER**

This document was prepared as an account of work sponsored by the United States Government. Neither the United States Government nor any agency thereof, nor The Regents of the University of California, nor any of their employees, makes any warranty, express or implied, or assumes any legal liability or responsibility for the accuracy, completeness, or usefulness of any information, apparatus, product, or process disclosed, or represents that its use would not infringe privately owned rights. Reference herein to any specific commercial products process, or service by its trade name, trademark, manufacturer, or otherwise, does not necessarily constitute or imply its endorsement, recommendation, or favoring by the United States Government or any agency thereof, or The Regents of the University of California. The views and opinions of authors expressed herein do not necessarily state or reflect those of the United States Government or any agency thereof or The Regents of the University of California and shall not be used for advertising or product endorsement purposes.

Lawrence Berkeley Laboratory is an equal opportunity employer.

## **DISCLAIMER**

This document was prepared as an account of work sponsored by the United States Government. While this document is believed to contain correct information, neither the United States Government nor any agency thereof, nor the Regents of the University of California, nor any of their employees, makes any warranty, express or implied, or assumes any legal responsibility for the accuracy, completeness, or usefulness of any information, apparatus, product, or process disclosed, or represents that its use would not infringe privately owned rights. Reference herein to any specific commercial product, process, or service by its trade name, trademark, manufacturer, or otherwise, does not necessarily constitute or imply its endorsement, recommendation, or favoring by the United States Government or any agency thereof, or the Regents of the University of California. The views and opinions of authors expressed herein do not necessarily state or reflect those of the United States Government or any agency thereof or the Regents of the University of California.

# THE USE OF REDOX POLYMERIZATION ELECTRODES IN LITHIUM BATTERIES WITH LIQUID ELECTROLYTES

M. M. Doeff, S.J. Visco and L.C. De Jonghe

Materials Sciences Division  
Lawrence Berkeley Laboratory  
University of California  
Berkeley, CA 94720

## INTRODUCTION

Solid redox polymerization electrodes (SRPEs) have generated much interest lately because of their excellent properties as cathodes for lithium-solid polymer electrolyte batteries. These properties include high power and energy densities and good cyclability[1] as well as low cost, environmental safety and ready availability. The electroactive material in SRPEs consist of a polydisulfide which can undergo reversible polymerization and depolymerization upon reduction and oxidation. This reaction is shown for the most widely studied redox polymer, X1, in equation (1).

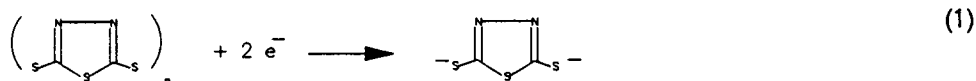

Although these redox polymers have proven to be outstanding cathode materials in solid state lithium batteries, little is known about their behavior in cells with liquid electrolytes. Because of the high conductivity of organic liquids, these cells should perform well at room temperature or lower. In this work, the properties of the solid redox polymer X1 vs lithium in liquid electrolyte and solvent swollen thin film cells of various configurations were investigated. Many of the cells that were assembled were discharged successfully at high rates, demonstrating the versatility of redox polymers as cathode materials. However, these results also indicate that the all solid state system holds much more promise for commercial applications including consumer electronic devices, and are probably much safer than lithium liquid electrolyte systems as well.

## EXPERIMENTAL

X1 was used for both the liquid electrolyte and the solvent swollen cells and was synthesized from 2,5 dimercaptotriazazole as described previously.<sup>1</sup> Premixed solutions of 1 M lithium perchlorate in propylene carbonate/dimethoxyethane (50/50 v/v) were obtained in ultrapure form from Mitsubishi Petrochemical Company. Alternatively, solutions were freshly made containing 50/50 v/v propylene carbonate/dimethoxyethane from Mitsubishi with 1 M lithium perfluoromethylsulfonimide (lithium ditriflate)

## ACKNOWLEDGEMENT

This research was supported by the Assistant Secretary for Conservation and Renewable Energy, Deputy Assistant Secretary for Utility Technologies, Office of Energy Management, Advanced Utility Concepts Division of the U.S. Department of Energy under Contract No. DE-AC03-76F00098.

as supporting electrolyte. The latter was a gift from Michel Armand (Ecole Nationale Supérieure d'Electrochimie et d'Electrometallurgie de Grenoble, France) 5 mil lithium foil (Lithco company, battery grade) was stored under helium and cut into disks 3 cm<sup>2</sup> in area just prior to use. For some cells, several lithium foils were stacked. Poly(ethylene oxide) (average MW = 5 X 10<sup>6</sup>), carbon black (Shawinigan acetylene black, Chevron) and lithium ditriflate were dried under vacuum at 50° C for several days and stored under helium prior to use. Carbon mats (1/16 inch thick, Electrosynthesis) for use in the liquid electrolyte experiments were cut into circles 3 cm<sup>2</sup> large and dried prior to use. Ethylene propylene terpolymer (EPDM, Exxon) was dissolved in cyclohexane and used as an inert porous binder in some experiments. Celgard 2400 microporous separators were cut to size and used in the liquid electrolyte cells.

For liquid electrolyte experiments, cathodes were made by passing a slurry of X1 polymer in acetonitrile over carbon mats and drying the impregnated mats under vacuum for several days. Loading levels of X1 ranged from 25 to 80 wt.%. Alternatively, mixtures of 3% EPDM, 24% carbon black and 73% X1 in cyclohexane were cast into 2032 buttons. The resultant homogeneous black mixtures were allowed to dry in air and then under vacuum for several days before being used as cathodes. Cells were assembled dry in open 2032 buttons and approximately 0.3 mL of solution carefully added so that the Celgard and cathode were thoroughly wetted. The cell configuration is shown in Figure 1a.

Positive electrodes for the solvent swollen experiments were prepared from a mixture of 30 wt% X1, 7-10 wt% C black, carbon dispersant (2-3 wt %) and the remainder poly(ethylene oxide) in acetonitrile. The mixtures were stirred thoroughly for several days. Films of 20-80 um thickness were cast and air-dried on a Teflon surface, cut into 2 cm<sup>2</sup> disks and vacuum-dried for at least two days. P(EO)<sub>8</sub>LiN(CF<sub>3</sub>SO<sub>2</sub>) separators were prepared similarly, although they were left on glass rings rather than being cut. Electrolyte solution containing lithium ditriflate was carefully swabbed onto the cathode and separator so that the final solvent swollen films contained 11 +/- 3% solution by weight. Some of the assembled batteries were allowed to sit for 24 hours before initial discharge to ensure uniformity of the solvent swollen films; however, this did not improve performance, so the waiting period was abandoned. The cell arrangement for the solvent swollen method is shown in Figure 1b.

Cells were discharged under an inert atmosphere at room temperature. The lithium electrode capacity in all cells exceeded that of the positive electrode by at least fourfold, and thus did not limit the cell performance. Discharge characteristics were examined with a PAR 173 or 371 potentiostat/galvanostat utilizing software developed in this laboratory. Cell impedances (typically less than 50 ohm<sup>-1</sup>-cm<sup>-1</sup>) were determined in situ by a pulse technique described elsewhere.[2]

## RESULTS AND DISCUSSION

Table 1 and Figure 2 summarize results obtained on X1 cells of two different cathode configurations, with PC-DME electrolyte mixtures. The open circuit voltage is 3.0 V at room temperature. Discharge characteristics did not change substantially with the type of supporting electrolyte used (lithium perchlorate or lithium ditriflate), but did vary somewhat with the method used for making the cathode.

Curves a and b show discharges for liquid electrolyte cells in which the cathode consisted of a carbon mat impregnated with X1 polymer. This is similar, but not identical to the technique used for the organodisulfide batteries, in which the active materials were dissolved in electrolyte and dropped onto carbon mats, which impart conductivity. X1, because it is insoluble, is added to the mats in the form of a slurry; the mats are then dried and electrolyte added when the cell is assembled. Thickness of these cathodes remained constant, but capacity (loading level) was varied. Cells with low loading levels and capacities (e.g. 25-50 wt %, corresponding to 3-6 C/cm<sup>2</sup>) could be discharged at high rates, with very good utilizations; 80% or more at C/5 rate, and 60-70% at C/2. When loading levels were increased, there was some loss in terms of percent utilization of the cathode, although more X1 was utilized overall (e.g. there is an increase from 4.8 C/cm<sup>2</sup> X1 utilized in curve a (50 wt.% X1) to 13.2 C/cm<sup>2</sup> in curve b (80 wt.% X1). Furthermore, it was possible to increase the current density as much as threefold; from 0.33 mA/cm<sup>2</sup> corresponding to C/5 rate in curve a, to 1 mA/cm<sup>2</sup> corresponding to C/6.7 rate in curve b. This is a rather surprising result indicating that there is little loss of power density with increased loading or capacity. However, loading could not be increased past 80 wt.% or inhomogeneity resulted and utilization decreased, most likely because X1 was not contacting carbon.

Cathodes were also made using carbon black, X1 and EPDM, a polymeric binder which becomes porous upon drying; these appeared very homogeneous and black, and had good mechanical integrity. Curves c and d in Figure 1 show the discharge behaviors of some of these cells. All cathodes had the same loading levels (73 wt.% X1) but different total capacities, i.e. thicknesses varied. Again, there was relatively little loss in percent utilization as capacity was increased up to a point, allowing current densities to be increased when thicker cathodes were used. Both curves c and d represent discharges at C/2.6 rate; this corresponds to a nearly threefold increase in current density for the thicker cathode (16.7 C/cm<sup>2</sup>) over the thinner cathode (6.2 C/cm<sup>2</sup>). However, this trend did not continue for very thick cathodes (above 25-30 C/cm<sup>2</sup>); the maximum utilization for these was about 8 C/cm<sup>2</sup> (or about 20-25% of the electroactive material) even when the current density was decreased to 0.5 mA/cm<sup>2</sup>.

It is apparent from these results that capacities cannot be increased past a certain point. Although loading levels can be quite high without much loss in utilization, a thick X1, EPDM cathode cannot be discharged efficiently, nor can the thin carbon mats be loaded beyond about 24 C/cm<sup>2</sup>. In addition to these practical problems, there may also be inherent limitations to the performance of these batteries due to the nature of the redox polymerization electrode chemistry. Although X1 is insoluble in PC-DME electrolyte,

the dithiolate salt produced upon discharge is very soluble. This results in an increase in ion concentration as discharge progresses, until the maximum solubility of dithiolate is reached ("salting out"). The effect of these concentration gradients upon the performance of the Li/X1 battery is undoubtedly complex, but certainly plays a role in the premature polarization seen in the cells with high capacity cathodes.

In the completely solid state cells, the liquid electrolyte is replaced by a polyethylene oxide (PEO) lithium salt complex which is conducting above 60° C. The cathodes and separators are generally very thin (on the order of 30 um, or surface capacities from 1 to 3 C/cm<sup>2</sup>) and utilizations at 0.5 mA/cm<sup>2</sup> are 80 to 100% at 90° C<sup>1</sup>. A large capacity battery may be made simply by increasing the total area of the cell or by stacking several cells. The addition of small amounts of PC-DME electrolyte (11 wt.%) to the PEO separators and cathodes results in a hybrid battery; these solvent swollen systems are extremely thin, like the solid state ones, but may be discharged at high rates at room temperature like those with conventional liquid electrolytes. Figure 3 shows the discharge characteristics of a solvent swollen cell at 25° C and those of a typical solid state cell at 90° C. Both have OCV's of 3.0 V, and were discharged at 0.5 mA/cm<sup>2</sup>. The addition of PC-DME greatly improves the performance of the thin film cells at room temperature, although polarization losses are increased as evidenced by the greater drop in voltage during discharge. (Comparable losses are also seen in the liquid batteries). Several attempts at cycling solvent swollen batteries were unsuccessful beyond about five cycles. This is in contrast to the all solid state cells which have been cycled more than three hundred times at 90° C.

## CONCLUSIONS

The results reported herein clearly demonstrate that X1 can be discharged successfully at high rates versus lithium in cells with liquid electrolytes or solvent swollen polyethylene oxide separators. Because of safety concerns over lithium batteries containing volatile organic liquids and the excellent results obtained on solid state Li/SRPE systems, we have shifted the focus of our work in this laboratory to the latter. Recent results show that the substitution of modified polymer electrolytes for PEO greatly improves performance at room temperature[3], effectively removing the last barrier to the commercialization of these devices for consumer use. Clearly, the outstanding performance and safety features of SRPE's can be more readily exploited when they are used in solid state systems, but the fact that they function well with liquid electrolytes demonstrates the versatility of these unique materials.

## ACKNOWLEDGEMENT

This research was supported by the Assistant Secretary for Conservation and Renewable Energy, Deputy Assistant Secretary for Utility Technologies, Office of Energy Management, Advanced Utility Concepts Division of the U.S. Department of Energy under Contract No. DE-AC03-76SF00098. The authors would like to thank Dr. Makoto Ue of Mitsubishi Petrochemical Company for helpful discussion.



**TABLE 1****Performance and Characteristics of Liquid Electrolyte Cells**

Cell Type <sup>a</sup>	Loading wt. % X1	Capacity C/cm <sup>2</sup>	Current Density mA/cm <sup>2</sup>	C Rate	Utilization (%)	Utilization C/cm <sup>2</sup>
carbon mat	50	6	0.33	C/5	80	4.8
carbon mat	80	24	1.0	C/6.7	55	13.2
EPDM	73	6.2	0.66	C/2.6	60	3.7
EPDM	73	16.7	1.66	C/2.6	38	6.4

a. See text for description.

## FIGURE CAPTIONS

Figure 1. Schematic of Li/X1 cells and cell holders. a) liquid electrolyte batteries. b) solvent swollen batteries.

Figure 2. Discharge curves for Li/X1 cells with PC-DME electrolyte at room temperature. a) carbon mat cathode, 6 C/cm<sup>2</sup> (50 wt. % X1), discharged at 0.33 mA/cm<sup>2</sup> or C/5 rate. b) carbon mat cathode, 24 C/cm<sup>2</sup>, (80 wt.% X1), discharged at 1 mA/cm<sup>2</sup> or C/6.7 rate. c) EPDM cathode, 6.2 C/cm<sup>2</sup> (73 wt.% X1), discharged at 0.66 mA/cm<sup>2</sup> or C/2.6 rate. d) EPDM cathode, 16.7 C/cm<sup>2</sup> (73 wt% X1), discharged at 1.66 mA/cm<sup>2</sup> or C/2.6 rate.

Figure 3. Discharge curves for Li/PEO/X1 cells at 0.5 mA/cm<sup>2</sup>. a) cell swollen with PC-DME; room temperature. b) solid state cell, 90° C.

### References

1. S.J. Visco, M. Liu, M. B. Armand and L. C. De Jonghe, *Mol. Cryst. Liq. Cryst.* ,190, 185 (1990).
2. S. J. Visco and M. Liu, submitted to *J. Appl. Electrochem.*
3. S. J. Visco, M. M. Doeff, M. Lerner, L. C. De Jonghe, unpublished results.

adjustable C-clamp

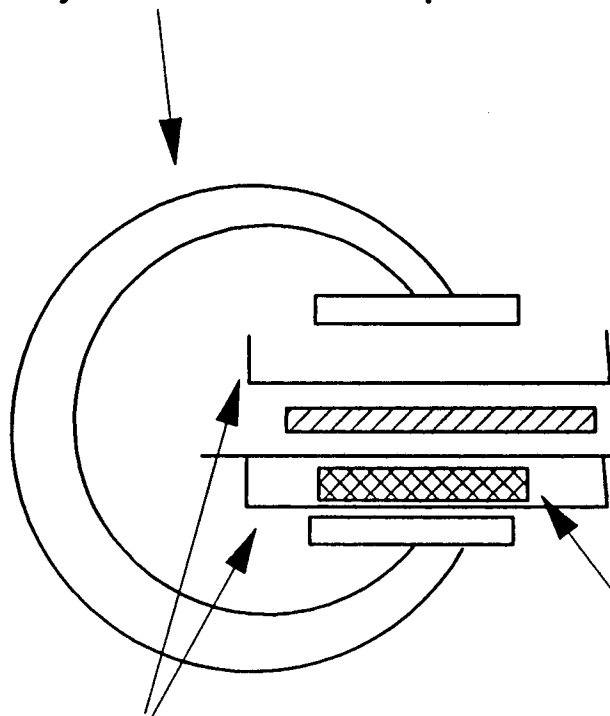

stainless steel pans

lithium

Celgard

cathode

a

current collector  
on adjustable plunger

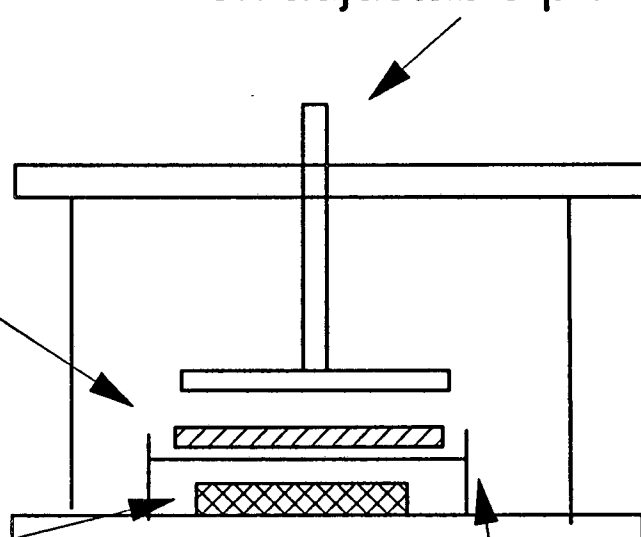

stainless steel

PEO separator  
on glass ring

b

Figure 1

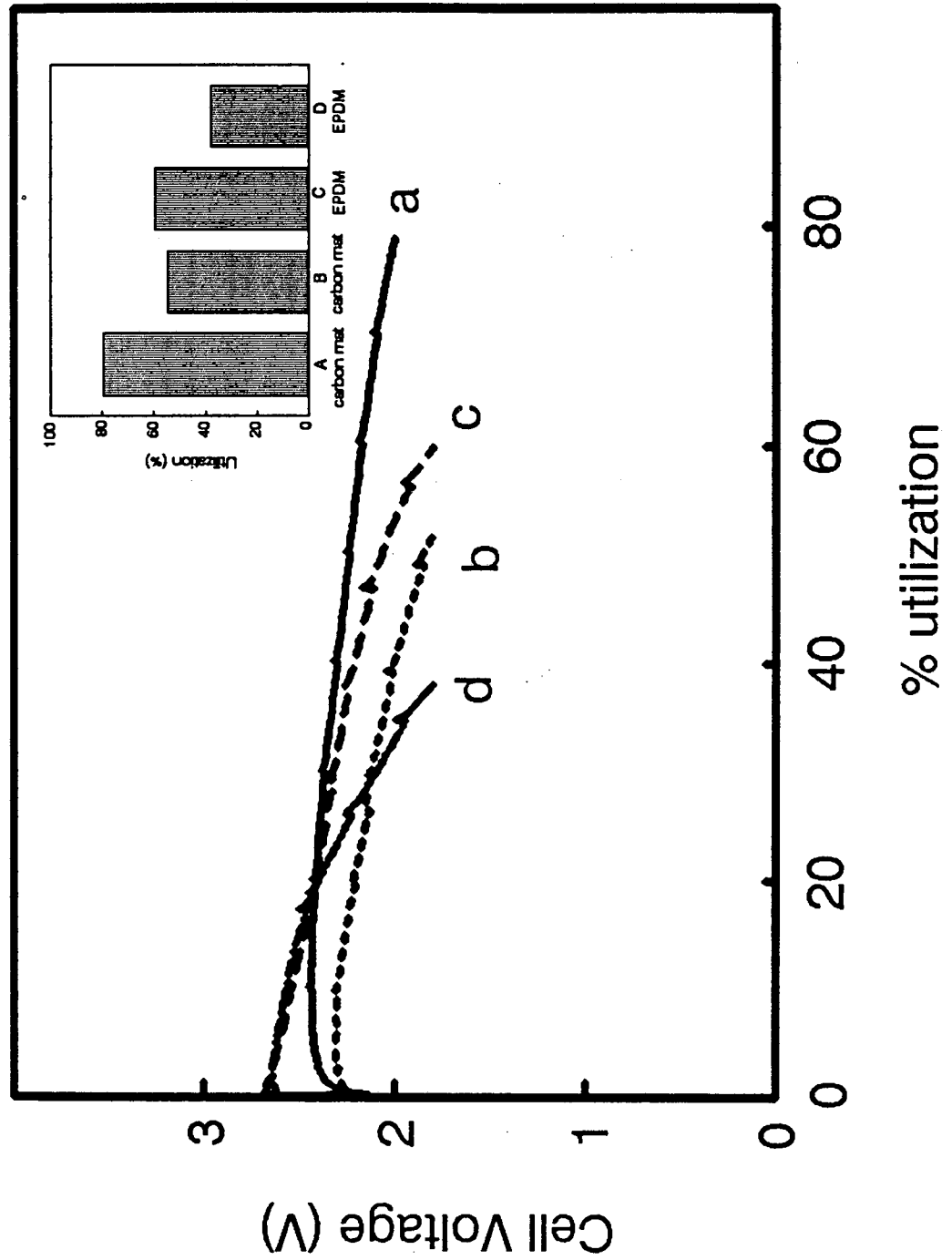

Figure 2

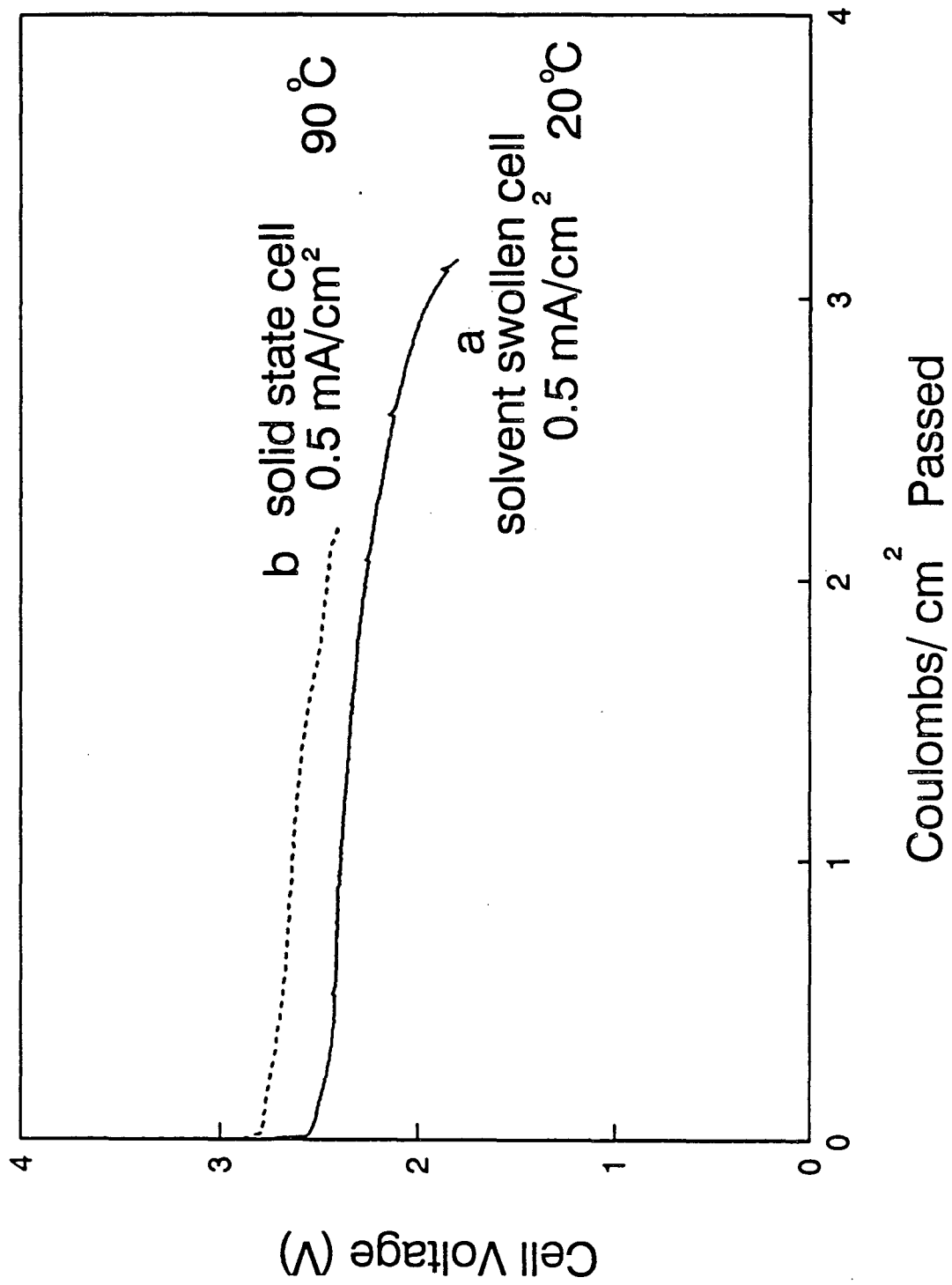

Figure 3

LAWRENCE BERKELEY LABORATORY  
UNIVERSITY OF CALIFORNIA  
INFORMATION RESOURCES DEPARTMENT  
BERKELEY, CALIFORNIA 94720