

UC San Diego

UC San Diego Electronic Theses and Dissertations

Title

Shadow on the steps : time measurement in ancient Israel

Permalink

<https://escholarship.org/uc/item/8q86391z>

Author

Miano, David Ringo

Publication Date

2006

Peer reviewed|Thesis/dissertation

UNIVERSITY OF CALIFORNIA, SAN DIEGO

SHADOW ON THE STEPS:
Time Measurement in Ancient Israel

A dissertation submitted in partial satisfaction of the
requirements for the degree of Doctor of Philosophy

in

History

by

David Ringo Miano

Committee in charge:

Professor David Noel Freedman, Co-chair

Professor William H.C. Propp, Co-chair

Professor Richard Elliott Friedman

Professor David Goodblatt

Professor Thomas E. Levy

Professor Alden A. Mosshammer

2006

©

David Ringo Miano, 2006

All rights reserved.

The Dissertation of David Ringo Miano is approved, and it is acceptable in quality and form for publication on microfilm:

Co-Chair

Co-Chair

University of California, San Diego

2006

TABLE OF CONTENTS

Signature Page..... iii

Table of Contents.....iv

List of Figures and Tables.....vii

Vita, Publications, and Fields of Study..... ix

Abstract..... x

Introduction..... 1

I. Calendars.....7

 A. Natural Units of Time.....7

 B. The Day as a Unit of Measurement..... 8

 1. The Hebrew Word for Day..... 8

 2. When Does the Day Begin and End?.....8

 3. Measurable Divisions of the Day.....15

 C. The Month as a Unit of Measurement.....22

 1. The Hebrew Words for Month.....22

 2. The Naming and Numbering of Months.....23

 3. When Does the Month Begin and End?..... 28

 4. Measurable Divisions of the Month..... 32

 D. The Year as a Unit of Measurement.....34

 1. The Hebrew Word for Year..... 34

 2. When Does the Year Begin and End?.....36

 a. The Agricultural Year.....36

 b. The Civil Year.....40

 c. The Liturgical Year.....45

 d. The Regnal Year.....46

 E. Lunar, Solar, and Lunisolar Calendars..... 52

II. Long-Time Reckoning.....55

 A. The Counting of Time Units..... 55

	B. The Egyptian Epoch and the Exodus Era.....	62
	C. Counting Generations.....	65
III.	Genealogical Chronologies.....	72
	A. Dating Events by the Life of an Individual.....	72
	B. Genealogical Lists Containing Chronological Information.....	74
	1. Description.....	74
	2. List-Making in the Ancient World.....	75
	3. Textual Variants of Genesis 5 and 11 and Their History.....	78
	a. Genesis 5.....	78
	b. Genesis 11.....	88
	C. Sources of the Priestly Genealogical Chronology.....	94
	1. Preliminary Considerations.....	94
	2. Pedigrees.....	99
	a. Ancient Linear Genealogies in General.....	99
	b. The Life Spans of the Forefathers.....	101
	c. A Generational Pedigree in Genesis 5 and 11.....	105
	3. Conclusions.....	110
IV.	Hegemonic Chronologies.....	113
	A. Chronological Sources of the Deuteronomistic History.....	113
	1. Time as Seen by the Deuteronomistic Historians and Their Audiences.....	113
	2. Chronological Sources for the Book of Jeremiah.....	114
	3. Chronological Sources Relating to the Judges.....	118
	4. Chronological Sources Relating to the Kings.....	125
	a. Preliminary Considerations.....	125
	b. King Lists.....	129
	c. Royal Chronicles.....	145
	d. Textual Difficulties in Kings.....	155
	e. Conclusions.....	173
	B. Historical Reconstructions.....	174
V.	Conclusions.....	209

Appendix A: Chronological Tables.....	217
Appendix B: What Happened in the Fourteenth Year of Hezekiah?.....	223
Bibliography.....	251

LIST OF FIGURES AND TABLES

Figure 1.1: The Cairo Shadow Clock.....	18
Figure 1.2: A Drawing of the Cairo Shadow Clock.....	19
Figure 1.3: Reconstruction of Ahaz’s Roof Chamber.....	19
Figure 1.4: The Shadow Created on the Steps According to the Sun’s Position.....	21
Table 1.1: Priestly Dates that Include Months.....	25
Table 1.2: Agricultural Activity in Modern Israel.....	36
Table 2.1: The Count of Days.....	57
Table 2.2: Time Covered by Solomon’s Building Activities.....	60
Table 3.1: Variant Readings of the Numbers in Genesis 5.....	78
Table 3.2: Variant Readings of the Numbers in Genesis 11.....	89
Table 3.3: Sources of the Ages in the Priestly Genealogy.....	111
Table 4.1: Readings for Abijam, Asa and Jeroboam.....	159
Table 4.2: Readings for Baasha and Elah.....	160
Table 4.3: Totalling the Years of Omri.....	160
Table 4.4: Counts for Omri Assumed in the Manuscripts.....	163
Table 4.5: Readings for Zimri, Tibni, Omri and Ahab.....	164
Table 4.6: Readings for Ahab, Jehoshaphat and Ahaziah.....	165
Table 4.7: Readings for Ahaziah, Joram and Jehoram.....	166
Table 4.8: Readings for Jehoram and Ahaziah.....	167
Table 4.9: Readings for Amaziah and Azariah.....	169
Table 4.10: Readings for Jotham, Ahaz and Hoshea.....	172
Table 4.11: Comparison of Extrabiblical Dates with Judahite King List Dates.....	183

Table 4.12: Comparison of Extrabiblical Dates with Israelite King List Dates.....	186
Table 4.14: Comparison of Extrabiblical Dates with Chronicle Dates for the Kings of Judah.....	207
Table 4.15: Comparison of Extrabiblical Dates with Chronicle Dates for the Kings of Israel.....	208
Table A.1: Chronology of Dtr ²	218
Table A.2: Chronology of Dtr ¹	219
Table B.1: Name Patterns in 2 Kings 18-19.....	246
Figure B.1: The Reordering of 2 Kings 18-20.....	249

VITA

1994 A.S. in Communications, Niagara County Community College
1999 B.A. in Classics, State University of New York at Buffalo
1999-2006 Section Instructor, Revelle Humanities Program, UCSD
2003 M.A. in History, University of California, San Diego
2005-2006 Adjunct Instructor, University of San Diego
2005-2006 Adjunct Instructor, San Diego Mesa College
2006 Ph.D. in History, University of California, San Diego

PUBLICATIONS

“Is the Shorter Reading Better? Haplography in the First Book of Chronicles”
([co-authored with David Noel Freedman] in *Emanuel: Studies in the Hebrew Bible, Septuagint and Dead Sea Scrolls in Honor of Emanuel Tov*, S. M. Paul, R. A. Kraft, L. H. Schiffman, and W. W. Fields, eds.; Leiden: Brill, 2003)

"People of the New Covenant"
([co-authored with David Noel Freedman] in *The Concept of Covenant in Second Temple Judaism*. S. Porter and J. deRoo, eds.; Leiden: Brill, 2003)

"Slip of the Eye: Accidental Omission in the Masoretic Tradition"
([co-authored with David Noel Freedman] in *The Challenge of Bible Translation: Essays in Honor of Ronald F. Youngblood*. G. Scorgie et al, eds.; Zondervan, 2003)

“The Deuteronomic History: A Brief Introduction”
(www.myjewishlearning.com, 2003)

“The Twelve *Sepharim* of the Torah”
(*The Biblical Historian* 1/1 [2004] 21-42)

FIELDS OF STUDY

Major Field: History (Ancient Israel and the Hebrew Bible)
Minor Field: Ancient Near Eastern History
Minor Field: Early Christian History

ABSTRACT OF THE DISSERTATION

Shadow on the Steps:
Time Measurement in Ancient Israel

by

David Ringo Miano

Doctor of Philosophy in History

University of California, San Diego 2006

Professor David Noel Freedman, Co-Chair
Professor William H.C. Propp, Co-Chair

Many historians and biblical scholars have attempted to make sense of the data found in the Hebrew Bible in order to reconstruct the time measuring systems that were in use in ancient Israel. Some have been more successful than others, but all who have tackled the problem have had difficulties in understanding the systems employed. The usual approach is to ignore the fact that the Bible is a collection of various writings from various times and places and to gather all of the chronological data from the entire collection and treat them homogeneously, hoping to find consistency among them. However, we can never comprehend the biblical data unless we treat each of the biblical sources as an independent unit. Once that is done, the picture becomes clearer. We find that the ancient Israelites had more than one calendar, more than one method of measuring intervals of time between events, and several different chronologies of its history.

INTRODUCTION

525,600 minutes, 525,000 moments so dear.
525,600 minutes - how do you measure, measure a year?
In daylights, in sunsets, in midnights, in cups of coffee.
In inches, in miles, in laughter, in strife.
In 525,600 minutes - how do you measure a year in the life?
How about love? How about love? How about love?
Measure in love. Seasons of love.
525,600 minutes! 525,000 journeys to plan.
525,600 minutes - how can you measure the life of a woman or man?
In truths that she learned, or in times that he cried.
In bridges he burned, or the way that she died.
It's time now to sing out, the story never ends.
Let's celebrate, remember a year in the life of friends.
Remember the love! Remember the love! Remember the love!
Measure in love. Seasons of love! Seasons of love.

—“Seasons of Love” by Jonathan Larson (from the musical *Rent*)

The measurement of time often depends on the vantage of whoever is doing the measuring. How *does* one measure a year? Or any other period of time? There is a certain amount of arbitrariness to the whole process. What do the measurers think is important? People do not measure time because time demands it but because *they* demand it. The effort proves useful to them in some way. Thus we find that not all natural units of time are measured, nor are more arbitrary units of time devised, unless for some necessity, purpose, or convenience.

The reasons the ancients measured time were not unlike our own reasons. It was necessary for farmers to keep track of the parts of the year, so that they knew when to plant and when to harvest and could plan for the future accordingly. Religious observances and holy days took place at special times, and it was necessary to set these times according to some standard of measurement. Time was likewise often a key factor in business transactions and appointments. Finally, ancient societies were interested in keeping track of their histories, and time measurement helped to create chronologies by

which they could orient themselves in relation to historical events in the past. It is the intention of this study to explore and analyze the methods used to do just this.

The particular society with which this work is concerned is stated in the title as “ancient Israel,” specifically the northern and southern Israelite kingdoms (Israel and Judah) in the period of their monarchies (circa 930-586 BCE), with attention also given to the United Monarchy (circa 1020-930 BCE). Recent scholarship has tended to be skeptical of the very possibility of recovering enough data from the ancient sources to reconstruct the time measuring systems that were in use in ancient Israel. James C. Vanderkam, for instance, known for his expertise in the Jewish calendar of the Second Temple period, expresses a typical opinion about the First Temple period: “One may assume that the ancestors of Israel and the early Israelites themselves followed some sort of calendar (or calendars), but the extant sources do not permit one to determine what its (their) nature may have been.”¹ I believe this statement is an exaggeration. The nature of ancient Israel’s calendars and other time-keeping systems *are* recoverable, at least partially, with a relative amount of certainty. One of the aims of this study is to demonstrate just that, and to show how far the evidence can actually take us.

To be sure, when dealing with any ancient society, evidence is much scarcer than for more recent societies. For ancient Israel the written evidence is indeed limited (more limited for northern Israel than for southern Judah), the archaeological evidence, while able to shed light on various aspects of the culture, tells us almost nothing about Israelite time keeping, and the oral traditions are, by their nature, no longer accessible. However,

¹ James C. VanderKam, "Calendars, Ancient Israelite and Early Jewish," in *Anchor Bible Dictionary*, ed. D.N. Freedman (New York: Doubleday, 1992) I: 814-20.

we do have recourse to some of the major cultural documents of the period, which have been preserved in the pages of the Hebrew Bible. The documents to which I have paid the closest attention are those generally considered to contain pre-exilic material: 1) the books of the early literary prophets: Amos (9th cent.), Hosea (9th cent.), Micah (8th cent.), Isaiah (8th cent.), Zephaniah (7th cent.), and Jeremiah (7th-6th cent.), and 2) the Primary History (Genesis-2 Kings), which has proved to be the richest resource of knowledge in this area. Care had to be taken with these works, because certain parts of them also contain later (i.e., exilic and postexilic) material.²

A few words should be said about the Primary History.³ The final version of the work has had a complex editorial pre-history that needs to be taken into consideration when doing a historical study. It cannot be assumed that such a large work, which is composed of many parts written by different authors, is going to have a synoptic view of time measurement. Moreover, parts of the Primary History were written outside of the time period to which this study is limited. We are required to approach the sources one at a time, each on its own terms, before making any judgments in this regard. If they do exhibit a similar view, this will come out, but if we make the assumption beforehand and analyze the text holistically, our data could be contaminated.

While it is not always easy to separate the sources of the Primary History, and scholars themselves are divided over the particulars, we may use the standard

² The other lengthy historical narrative in the Bible (1-2 Chronicles-Ezra-Nehemiah) was not used for this study because of its late (postexilic) date. The chronological data of clear pre-exilic origin found therein are by and large a repetition of that found in the Primary History.

³ To the best of my knowledge, the term "Primary History" was coined by D.N. Freedman, "Pentateuch," in *Interpreter's Dictionary of the Bible* (1962) III: 711-27.

Documentary Theory as a point of departure. According to that model, the main sources are as follows:

The Yahwistic History. The narrative commonly called J, although not concerned chiefly with matters related to time measurement, is an invaluable source of information for pre-exilic customs. The document is reputed to have originated in Judah in the period of the Divided Monarchy (c. 930-c. 720 BCE).⁴ Because of the close affinity between J and other early Judahite sources of the Primary History, such as the so-called Court History of David, I treat them together; indeed a good argument has been made that the same author is responsible for these works anyway.⁵

The Priestly Source. The P document is full of data related to priestly interests and liturgical matters. Its author(s) are very interested in matters of time measurement. Law codes make up a significant part of this source, but there is historical narrative as well. Scholars are still divided over whether one or both of these parts derive from the pre-exilic or postexilic period. Because of the strong evidence for a pre-exilic date for much of the material,⁶ I have chosen to include analysis of this source in the present

⁴ For a survey of scholarship, see A. de Pury, "Yahwist ("J") Source," *ABD* VI: 1012-1020. For recent discussions of the date of J, see Ernest Nicholson, *The Pentateuch in the Twentieth Century* (Oxford: Clarendon Press, 1998), 132-95, Richard M. Wright, *Linguistic Evidence for the Pre-exilic Date of the Yahwistic Source* (New York, NY: T & T Clark, 2005).

⁵ See Richard Elliott Friedman, *The Hidden Book in the Bible* (San Francisco: HarperSanFrancisco, 1998) For a list of the passages attributable to this author, see p. 12 of the above work.

⁶ See Moshe Weinfeld, *Deuteronomy and the Deuteronomistic School* (Oxford: Oxford University Press, 1972), 179-89, Avi Hurvitz, "The Evidence of Language in Dating the Priestly Code," *Revue Biblique* 81 (1974): 24-56, Robert Polzin, *Late Biblical Hebrew: Toward an Historical Typology of Biblical Hebrew Prose* (Atlanta: Scholars Press, 1976), Menahem Haran, *Temples and Temple Service in Ancient Israel* (Oxford: Oxford University Press, 1978), Gary A. Rendsburg, "Late Biblical Hebrew and the Date of P," *JANES* 12 (1980): 65-80, Richard Elliott Friedman, *The Exile and Biblical Narrative: the Formation of the Deuteronomistic and Priestly Works* (Chico, Calif.: Scholars Press, 1981), Menahem Haran, "Behind the Scenes of History: Determining the Date of the Priestly Source," *Journal of Biblical Literature* 100.3 (1981): 321-33, Avi Hurvitz, *A Linguistic Study of the Relationship Between the Priestly Source and the Book of Ezekiel* (Paris: Gabalda, 1982), Ziony Zevit, "Converging Lines of Evidence Bearing on the Date of P," *ZAW* 94 (1982): 502-09, Avi Hurvitz, "Dating the Priestly Source in Light of the Historical Study of

study. One needs to be careful, however, to distinguish between original P and the work of the later priestly Redactor (R), who edited P and other documents in the postexilic period.⁷

*The Deuteronomistic History.*⁸ This lengthy work, recounting the exploits and excesses of the Judahite and Israelite kings, contains a large amount of chronological data, some of it from contemporary sources and some from earlier times. One needs to be careful, however, to distinguish between the older Josianic edition of the history, which reflects preexilic customs, and the material added in the later exilic edition.⁹

Biblical Hebrew a Century after Wellhausen," *ZAW Supplement* (1988): 88-100, Jacob Milgrom, *Leviticus 1-16*, AB 3 (New York: Doubleday, 1991), 3-35, Richard Elliott Friedman, "Torah," in *Anchor Bible Dictionary*, ed. David Noel Freedman (New York: Doubleday, 1992) VI: 605-22, Jacob Milgrom, "The Antiquity of the Priestly Source," *ZAW* 111 (1999): 10-22.

⁷ See Friedman, *Exile and Biblical Narrative*, 77-80, Richard Elliott Friedman, *Who Wrote the Bible?* (Englewood Cliffs, N.J.: Prentice Hall, 1987, 1997), 217-33, Nicholson, *The Pentateuch in the Twentieth Century*, 215-18.

⁸ This history is variously referred to by scholars as the "Deuteronomic History" and the "Deuteronomistic History," with the latter being the current favorite. Although I follow convention here, I am of the opinion that "Deuteronomistic History" is a misnomer. While the adjective "Deuteronomistic" ("having the character of the Deuteronomist") is an appropriate description of the author(s) or editor(s) of this history, it is not fitting for the history itself, since the comparison is not between the history and the Deuteronomist, but between the history and the writing that inspired it, the Deuteronomic code. The designation "Deuteronomic History" therefore seems more appropriate.

⁹ This study accepts the two-edition theory of the Deuteronomistic History. The evidence for an original Josianic edition and an updated exilic edition is presented in the following: James A. Montgomery, *A Critical and Exegetical Commentary on the Books of Kings*, ed. Henry Snyder Gehman, ICC (New York: Charles Scribner's Sons, 1951), 44-45, Wolfgang Richter, *Traditionsgeschichtliche Untersuchungen zum Richterbuch* (Bonn: Peter Hanstein, 1963), idem, *Die Bearbeitung des 'Richterbuches' in der deuteronomistischen Epoche* (Bonn: Peter Hanstein, 1964), Frank Moore Cross, "The Structure of the Deuteronomic History," in *Perspectives in Jewish Learning* 3 (Chicago: 1968): 9-24, John Gray, *I and II Kings*, 2nd ed., OTL (Philadelphia: SCM Press, 1970), 6-9, Frank Moore Cross, *Canaanite Myth and Hebrew Epic* (Cambridge: Harvard University Press, 1973), 274-89, I. Schlauri, "W. Richters Beitrag zur Redaktionsgeschichte des Richterbuches," *Bib* 54 (1973): 367-403, E. Cortese, "Problemi attuali circa l'opera deuteronomistica," *Rivista biblica italiana* 26 (1978): 341-52, esp. 343-47, Richard Elliott Friedman, "From Egypt to Egypt: Dtr1 and Dtr2," in *Traditions in Transformation: Turning Points in Biblical Faith*, ed. B. Halpern and J. D. Levenson (Winona Lake: Eisenbrauns, 1981): 167-92, Friedman, *Exile and Biblical Narrative*, Richard D. Nelson, *The Double Redaction of the Deuteronomistic History* (Sheffield: JSOT Press, 1981), P. Buis, "Rois," in *SDB* 9 (1982): cols. 695-750, especially cols. 728-31, H. G. M. Williamson, "The Death of Josiah and the Continuing Development of the Deuteronomic History," *Vetus Testamentum* 32 (1982): 242-43, Norbert Lohfink, *Rückblick im Zorn auf den Staat, Vorlesungen zu ausgewählten Schlüsseltexten der Bücher Samuel und Könige* (Frankfurt: Privatdruck, 1984).

Northern materials in the Primary History. It is believed that Northern stories made their way into the Primary History as well. The parts in the Torah attributed to an E source are usually considered Northern, and there are similar narratives in Samuel and Kings. They are believed to be from the period of the Divided Kingdom (c. 932-720 BCE).¹⁰

The present work is divided into four chapters. The first deals with the yearly calendar and addresses questions pertaining to how the Israelites kept track of the astronomical cycles. The following three chapters are concerned with chronography, that is, the method of measuring intervals of time between events in order to understand how far removed these events were from the time of the measurers. Chapter Two examines the manner in which long periods of time were calculated and understood. Chapter Three deals with chronologies based on genealogies that were constructed by the priests, and Chapter Four treats the chronologies that were based on the reigns of judges and kings.

¹⁰ See A. W. Jenks, *The Elohist and North Israelite Traditions*, Society of Biblical Literature Monograph Series (Missoula, MT: SBL, 1977), Friedman, "Torah," 605-22, A. W. Jenks, "Elohist," in *Anchor Bible Dictionary*, ed. David Noel Freedman (New York: Doubleday, 1992) II: 478-82.

I.

CALENDARS

A. Natural Units of Time

The natural intervals of time that commonly come into play in the construction of calendars are 1) the day, 2) the synodic month, and 3) the tropical year. Most societies are interested in keeping track of all three phenomena, but the three are not quite compatible with one another, so calendars are forced either to ignore one of them (usually the second or third) or to accommodate them all by some sort of artificial manipulation.

For purposes of measurement, the 24-hour day may be taken as a constant unit, and so may the tropical year, but it is clear from the length of the latter (365 days, 5 hours, 48 minutes, and 46 seconds) that an even number of days will not fit into it. The synodic, or lunar, month averages 29 days, 12 hours, 44 minutes, and 2.78 seconds, but varies in length (up to 13 hours) and is not often divisible by an even number of days, nor is an even number of months able to fit into a tropical year.

The ancients, while not able to measure all of these time intervals with precision, were nevertheless well aware of their approximate lengths and of the difficulties associated with constructing calendars that took all of them into consideration. Length of days was determined by observation of the sun (its rising and setting), length of months by observation of the moon (its waxing and waning), and length of years also by observation of the sun (the solstices and equinoxes).

B. The Day as a Unit of Measurement

1. The Hebrew Word for Day

The term used throughout the Hebrew Bible to refer to a 24-hour period is יום. This word has several other meanings as well, which may indicate more general periods of time, some greater and some lesser than one day,¹¹ but when it comes to quantitative measurement of time יום is used only to refer to a 24-hour span.

Occasionally in quantitative measurement יום is used along with the coordinate term לילה (night) to refer to one complete day. Thus for example we are told that the length of the period of rainfall during the Flood was “forty days and forty nights” (or better, “forty daytimes and forty nighttimes”). In these cases, יום represents, not the complete diurnal period, but only the part of the day during which the sun is up. However, daytimes are never *counted* without nighttimes.

2. When Does the Day Begin and End?

Although it is obvious that a day is made up of a complete period of daylight and a complete period of night, it is necessary, for calendrical purposes, to choose a specific point for the change of date. Observation of the sun would have been important for this determination in antiquity. The Egyptians began their official day at sunrise,¹² and the Mesopotamians and Athenian Greeks at sunset.¹³

¹¹ Gershon Brin, *The Concept of Time in the Bible and the Dead Sea Scrolls*, ed. F. Garcia Martinez, Studies on the Texts of the Desert of Judah, vol. 34 (Leiden: Brill, 2001), 52-57, 142-45.

¹² K. Sethe, "Die Zeitrechnung der alten Ägypter im Verhältnis zu der der andern Völker," in *Nachrichten von der Königlichen Gesellschaft der Wissenschaften zu Göttingen, Philologisch-historische Klasse aus*

A subject of debate over the years has been when the ancient Israelites understood the day to have begun. Two main camps exist: those who believe the Israelite day began in the morning, and those who believe it began in the evening. When addressing this problem it is important to keep in mind that we cannot assume that every source in the Bible agrees in this regard, so we will consider each of the sources separately.¹⁴ To be sure, we should expect that any given ancient society would hold a general and prevalent view, but these documents do not all derive from the same time period, and ideas may have changed over the centuries. Also important to note is that none of the authors of these texts see any need to explain when the day begins. Their audiences already know that, and so we can only attempt to ascertain what the *assumptions* are regarding the beginning of the day in these documents.¹⁵

1) **J.** The evidence is fairly clear that in J (a southern source) the day begins at sunrise. For example, in the story of Lot and his daughters, the girls intoxicate Lot and have sex with him at night, and the next morning is said to be the *next* day (Gen 19:33-

dem Jahre 1920 (Berlin: 1920): 130-38, Richard A. Parker, *The Calendars of Ancient Egypt*, S.A.O.C. 26 (Chicago: University of Chicago Press, 1950), 9-23, Marshall Clagett, *Ancient Egyptian Science*, vol. II (Independence Square: American Philosophical Society, 1995), 22.

¹³ Richard A. and Waldo H. Dubberstein Parker, *Babylonian Chronology, 626 B.C. - A.D. 75*, 3rd ed. (Providence: Brown University Press, 1956), 26, Elias J. Bickerman, *Chronology of the Ancient World* (Ithaca: Cornell University Press, 1968), 13-14, Alan E. Samuel, *Greek and Roman Chronology: Calendars and Years in Classical Antiquity* (München: Beck'sche Verlagsbuchhandlung, 1972), 13

¹⁴ Unless otherwise indicated, I follow the source divisions of Richard Elliott Friedman, *The Bible with Sources Revealed* (San Francisco: HarperSanFrancisco, 2003).

¹⁵ Most of the observations that follow have been made by others (though in most cases without distinction between sources). See Julian Morganstern, "Supplementary Studies in the Calendars of Ancient Israel," in *Hebrew Union College Annual* (1935) X: 1-148, Roland de Vaux, *Ancient Israel: Its Life and Institutions* (London: Darton, Longman, and Todd, 1961), 180-83, H. R. Stroes, "Does the Day Begin in the Evening of Morning? Some Biblical Observations," *Vetus Testamentum* XVI (1966): 460-75, Shemaryahu Talmon, "Whence the Day's Beginning in the Biblical Period and in the Beginning of the Second Temple Period?" in *The Bible as Reflected in its Commentators*, ed. S. Japhet (Jerusalem: Magnes, 1994): 109-29, Roger T. Beckwith, *Calendar and Chronology, Jewish and Christian* (Leiden: Brill, 1996), 6-7, Brin, *Concept of Time*, 153-64.

34).¹⁶ Such could not have been the case if the day began at sundown, because the following morning would have been considered the *same* day. The assumption is that the day begins at sunrise. In Dtr's early monarchic sources akin to J, we find similar evidence. In the story of the dismembered concubine, the father of the young woman views the nighttime as the close of the day, rather than the beginning of a new one, and the morrow begins early in the morning (Jud 19:9). Similarly, when the Israelites build an altar to Yahweh after the decimation of Benjamin, they do it early in the morning, when the next day begins (Jud 21:4). When Saul tries to kill David in the nighttime, David's wife Michal refers to the morning as the next day (1 Sam 19:10-11).¹⁷

2) **E.** Not much evidence is available for the beginning of the day in E. However, it would seem that the day also begins at sunrise. In the account about the gathering of quail by the Israelites in the desert, the people are said to have gotten up to gather the birds "all that day and all night, and all the next day" (Num 11:32). It is probable that the first "day" mentioned is limited to the daytime, that is, the sunlight hours, since it is used side-by-side with "night" (the usual idiom). The second use of "day," however, is not used in conjunction with "night;" instead we find the adjective *הַמָּחָרָת* ("the morrow"), which is commonly used when *יוֹם* refers to a complete calendar day (as in the J examples cited above). The second *יוֹם* therefore must refer to the entire diurnal period. In other words, the next day is not the next daytime, but the next full day. If so, E's day begins at the conclusion of the nighttime, i.e., at sunrise. Also worthy of mention is one

¹⁶ Although Heb. *מָחָרָת* (an adjective) is often used by itself, the implied noun is *יוֹם* (cf. Gen 30:33). See G. André, "מָחָר," in *Theological Dictionary of the Old Testament*, ed. G. J. Botterweck et al. (Grand Rapids: Eerdmans, 1997) VIII: 237-41.

¹⁷ Cf. also 1 Sam 5:2-4.

of Dtr's sources for the story of Gideon (6:34-40; 7:2-11, 13-22a, 22c-25).¹⁸ A fleece is laid out overnight, and the next morning is considered the next day (6:37-38).

3) **The Deuteronomistic History.** Very little can be found in the DH to assist us in ascertaining when the Historian understood the day to begin. The most significant passage is at Joshua 5:10-12, which is a reference to the Passover and based upon legislation in the Deuteronomic Code (Deut 16:1-9). The historian states that the Passover was celebrated in the evening.¹⁹ The reason given for the commemoration in the evening is not because the day begins in the evening, but because the evening was the "time of [their] coming out of Egypt" (Deut 16:6). In Joshua, reference is made to "the day after the Passover," on which the people eat from the produce of the land. The implication is that their eating of the land's yield occurs on the following morning and afternoon. Those who would argue for a day beginning in the evening would have to assume that, since the following morning and afternoon are still part of the same day on which the meal was eaten, then the gathering of the produce from the land did not occur until at least 24 hours from the evening that the Passover was celebrated, but probably even later, since the gathering would not have been done in the dark, but would have been delayed until daylight. However, since the eating of unfermented cakes is

¹⁸ The tribe of Ephraim plays the heroic role, so the story may be of northern origin. For evidence that the Gideon passages are not authored by the Deuteronomistic Historian, but are independent sources, see J. Alberto Soggin, *Judges: A Commentary* (Philadelphia: Westminster Press, 1981), 103-05.

¹⁹ The word ערב ("evening") comes from a root meaning "to enter" and refers to the sun's retiring into its resting place beneath the horizon, as is shown by the frequent combination of ערב with בא השמש (e.g., Deut 16:6; 23:12[11]; Josh 8:29; 10:26-27). When referring to a point in time, it has the meaning "sunset," and when to a general time, the period following sunset. See H. Niehr, "ערב," in *Theological Dictionary of the Old Testament*, ed. G.J. Botterweck et al. (Grand Rapids: Eerdmans, 2001) XI: 335-41. The statement that the Passover was celebrated on the 14th of the month may be an addition to bring the account into harmony with the priestly legislation. The Deuteronomic law specifies the month, but not the day, of the Passover. It does, however, say the sacrifice should be made in the evening (Deut 16:4). On the other hand,

commanded to take place over *six* days (Deut 16:8), the gathering of the produce to make those cakes *must* be understood to occur on the morning following the Passover celebration, when the people would have been instructed to return to their tents (Deut 16:7). The morning after the Passover sacrifice is therefore considered the next day by the Deuteronomistic Historian.

4) **P**. The evidence from P is more plentiful, but sometimes appears contradictory. Nevertheless, it would seem that the priests too understood the day normally to begin at sunrise. When the Sabbath is instituted during the desert wanderings, Moses says, “Tomorrow is a ceasing, a holy Sabbath to Yahweh” (Exod 16:23), and when the following morning arrives, Moses says, “Today is a Sabbath to Yahweh” (Exod 16:24-25). The new day clearly begins in the morning. In the Law, Yahweh commands, “The meat of [the priest’s] peace-offering shall be eaten *on the day* of his offering. *He shall not leave any of it until morning*” (Lev 7:15). The morning here is understood to be on the following day (see also Lev 22:30).²⁰

Some have argued that P’s creation account, now in the first chapter of Genesis, suggests that the priests counted the beginning of the day from the evening.²¹ The repeated refrain, “and evening came, and morning came,” on each creative day suggests to some that the author is stating the order of the day. A few considerations should lay this argument to rest:

perhaps the message in Joshua is that the tradition for celebrating the Passover on the 14th is to be traced to this occasion; it was the day the Israelites celebrated it after entering the Promised Land.

²⁰ One might also look at the evidence from the priestly Redactor of the Primary History, who, although writing at a later time, includes a source document in Numbers 33, which also suggests that the day begins at sunrise. It is stated therein that the fifteenth day of the first month was on the morning after the Passover, which was observed on the fourteenth day of the month (Num 33:3).

²¹ E.g., Morganstern, "Supplementary Studies in the Calendars of Ancient Israel," 19.

1) The combination ערב (“evening”) and בקר (“morning”) is not equivalent to לילה (“nighttime”) and יום (“daytime”), and in fact does not add up to a complete day, but amounts only to two lesser parts of one day. We cannot, therefore, understand the two-fold refrain as constituting some kind of summation of two parts of an entire day of creation.

2) The appearance of the consecutive *waw* before the refrain suggests that the evening and morning are part of a sequence of events. We should not therefore understand them in isolation from the rest of the events mentioned on any given creative day. The sequence is as follows: 1) act or acts of creation; 2) evening; 3) morning. The evening clearly follows the creative activity that occurs during the day.

3) If the evening follows God’s creative acts on any given day, the evening cannot be the beginning of the day, but rather would be the concluding part of it. It is the morning that would signal the transition from one day to the next.²²

Far from demonstrating the day to begin in the evening, P’s creation account adds further support to the conclusion that P assumes a day that begins at sunrise.²³

Another set of evidence used to demonstrate a day beginning in the evening in the priestly material is that related to the holy days. The Sabbath runs from evening to evening (Lev 23:32). The Feast of Unleavened Bread lasts from the evening of the fourteenth day of the first month of the year until the evening of the twenty-first day of the month, seven days from evening to evening (Exod 12:18-19). This evidence

²² Note especially the first day, in which the appearance of light begins the day.

²³ See Jacob Milgrom, *Leviticus 23-27* (New York: Doubleday, 2001), 1967-68, 2025-26

seemingly points to a day that begins in the evening. Suggestive also is the fact that the paschal offering on the first of those days is to take place “between the evenings” (Exod 12:6; Lev 23:5; Num 9:3, 5, 11), an expression that appears to mean the time between sunset and full night.²⁴ Some sacrifices are also to be made “between the two evenings” (Exod 29:39, 41; 30:8).

However, the very fact that the Law has to specify that observances and special performances take place in the evening or run from evening to evening suggests that such was not normally the case. If the day began at sundown, then the only necessary information would be the date of the observance (e.g., that the Sabbath is on the seventh day of the week). It would already be understood that such days begin and end in the evening. Yet the Law makes a point to highlight that such observances must commence in the evening. This evidence actually implies a day that does *not* usually begin at such a time.²⁵

As the preceding survey demonstrates, all of the main sources in the Primary History (J, E, Dtr, and P) assume a day that begins and ends at sunrise. The broad agreement suggests that this was a general view for a long period of time. P, however, appears to have a different system of reckoning the day when it comes to rituals of the cult. Indeed, it would seem that P makes an effort to impose its liturgical day onto the existing system (cf., for example, the problem of naming the date of the Day of Atonement, which is to take place between evenings; Lev 23:27, 32). We cannot therefore interpret P’s regulation as evidence of a *change* in the reckoning of the day’s

²⁴ See discussion in William H. C. Propp, *Exodus 1-18* (New York: Doubleday, 1999), 390-91

²⁵ See also *Ibid.*, 390-92, Milgrom, *Leviticus 23-27*, 1967-69.

beginning. Its liturgical day presupposes, and therefore exists side by side with, the secular day.

A question we might ask is: Is a day beginning in the evening an innovation of the priests (or something borrowed from another culture), or is P incorporating or preserving an older system? Rituals tend to have long lives, so it is certainly possible that the priests are preserving an ancient practice, but we have no evidence for an evening-to-evening day in any source older than P. Both P's liturgical year (as we shall see) and P's festival day begin at different times than in the other biblical sources (including the P narrative), and they both appear to imitate foreign custom. It therefore seems more probable that the liturgical calendar was based on foreign systems than on an early Israelite one.

3. Measurable Divisions of the Day

The Bible writers do not often divide the day into measurable parts. Although general designations exist, like בוקר (“morning”), צהרים (“midday”), ערב (“evening”), and חצי הלילה (“the middle of the night”), these are not clock times, nor are they used in chronological measurement. There is, however, limited evidence of quantifiable divisions of the day from which we may draw some educated conclusions.

Several writers use the term אשמרה to designate a fixed period of time during which a guard keeps watch, and it would seem that over time the word, which originally came from a military context, carried over into everyday language.²⁶ Each watch seems to have borne a name, but the Bible does not provide us with the names of all of the watches. The “morning watch” (אשמרת הבקר) is spoken of in two places (Exod 14:24; 1

Sam. 11:11, both J), and once we hear of a “middle watch” (הַאֲשֵׁמֶרֶת הַתִּיכּוֹנָה) (Judg 7:19, Dtr or one of its sources). All of the watches appear to be associated with the nighttime, including, it would appear, the morning watch, in which daybreak seems to have occurred (cf. Ps 63:6; Ps 90:4; Ps 119:147-148). However, Lamentations 2:19 suggests that **רֵאשׁ הַאֲשֵׁמֶרֶת** (the start of the watches) occurred in the morning and therefore that watches were kept all throughout the day.²⁷ Since one of the night watches is referred to as the “middle” watch, we are justified in assuming an odd number of night watches, most likely three. These would consist of an early evening watch, the middle watch, and probably the morning watch. This three-fold division was also the practice of the Babylonians,²⁸ and the Greeks in Homer’s time.²⁹ In a night 12 hours long, each watch would have been approximately 4 hours in duration. We would expect a similar division of the daytime, with three watches of about 4 hours each. As the length of daylight changed throughout the year, the length of the watches would no doubt have been affected, with the night watches being longer in the winter and shorter in the summer. Time would have been measured during the day by the position of the sun, and during the night by the position of the stars. Customs may have varied from place to place, but it is impossible with the scanty information the Bible provides to make any further judgments.

Apart from the **אֲשֵׁמֶרֶת**, the only other reference to measured divisions of the day occurs in a narrative about Isaiah and King Hezekiah. When the king asks the prophet

²⁶ Cf. Greek φυλακται and Latin *vigiliae* (Bickerman, *Chronology of the Ancient World*, 14).

²⁷ Lam 2:19 is another source of evidence for a day beginning at sunrise.

²⁸ Bickerman, *Chronology of the Ancient World*, 14.

²⁹ *Iliad* X: 253; *Odyssey* XII: 312.

for a sign that he will recover his health, the latter performs a miracle that suggests the turning back of time: he causes a shadow on a flight of steps, which had been moving forward, to recede (2 Kings 20:8-11 = Isaiah 38:22, 7-8).

The steps upon which the shadow moves is of particular interest to us, because it would appear that they are to be understood as part of some sort of time-keeping device that was set up at the king's palace to measure the passing of the day by the sun's shadow. They are called **מעלות אחז** ("the steps of Ahaz") in MT, a name that suggests that the clock was installed by Hezekiah's father. There is a good chance, however, that the phrase has been shortened accidentally through a scribal error (haplography). In the Isaiah text, several witnesses (LXX, 1QIsa^a, Vulg., Targ.) carry the additional word **עלית** between the two nouns (**מעלות עלית אחז** instead of **מעלות אחז**).³⁰ The similarity between the two words **מעלות** and **עלית** could easily have led a scribe's eye astray, so that the second word was skipped during the copying process in the Masoretic scribal tradition. A parent reading of **מעלות עלית אחז** ("the steps of the roof chamber of Ahaz") is likely. The reference to **עלית אחז** ("the roof chamber of Ahaz") elsewhere (2 Kings 23:12) establishes the existence of such a place and adds further credence to the longer reading.³¹ The attribution of the roof chamber to Ahaz may be an allusion to the alterations he had made to the palace complex earlier in the narrative (2 Kings 16:17-18), alterations which seem to have included cultic innovations borrowed from Assyria. The steps may have been part of the new design. Yadin draws attention to Egyptian shadow clocks, one type of which consisted of two flights of stairs (one set facing east and one

³⁰ LXX has "your father" instead of "Ahaz."

facing west), upon which the sun's shadow fell, and this may be the closest equivalent we can find.³² One example of this type is part of a clock now in the Cairo Museum (No. 33401) and generally dated to the later New Kingdom period.³³ A photo and drawing appear below:³⁴

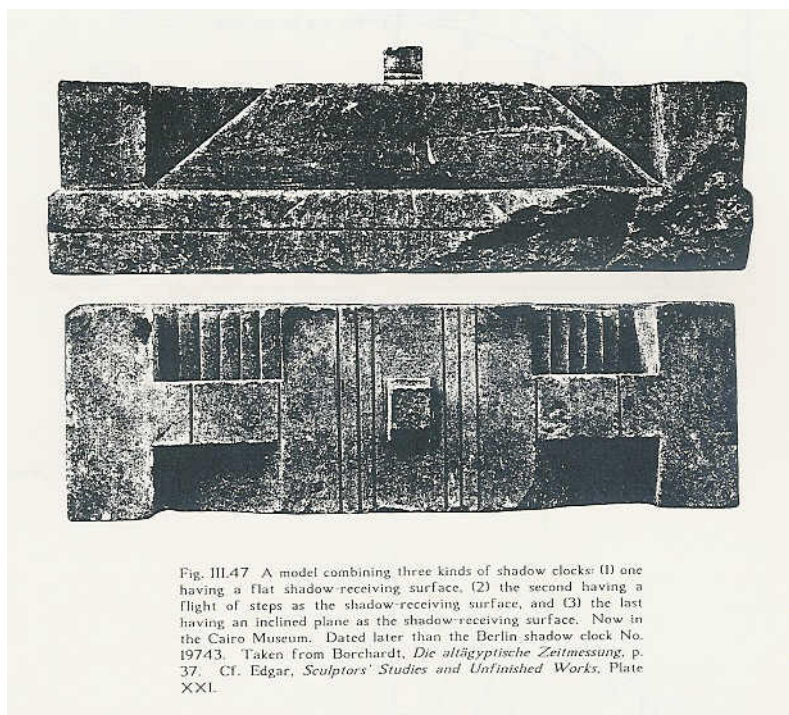

Figure 1.1: The Cairo Shadow Clock.

³¹ See Samuel Iwry, "The Qumran Isaiah and the End of the Dial of Ahaz," *Bulletin of the American Schools of Oriental Research* 1.147 (1957): 27-33.

³² Yigael Yadin, "מעלות אהז," *Eretz Israel* 5 (1958): 91-96.

³³ Claggett, *Ancient Egyptian Science*, 93-94.

³⁴ Taken from *Ibid.*, "Illustrations" (page unnumbered).

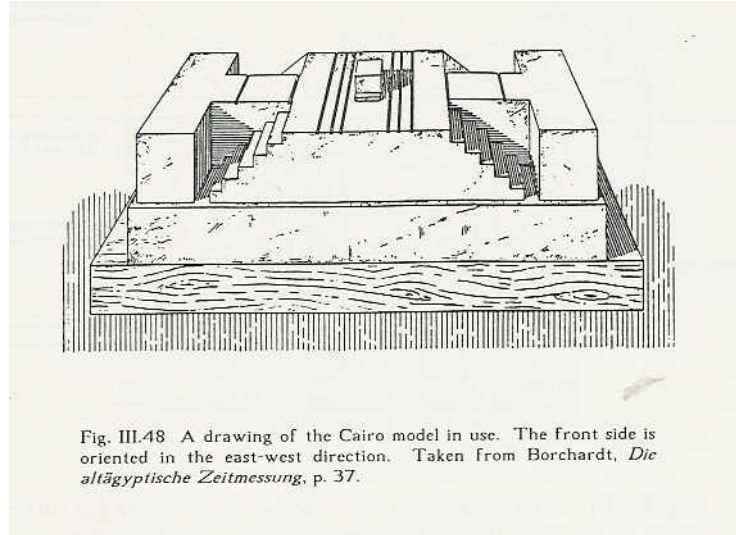

Figure 1.2: A Drawing of the Cairo Shadow Clock.

Based on this model, the roof chamber of Ahaz may have looked something like figure 3.³⁵

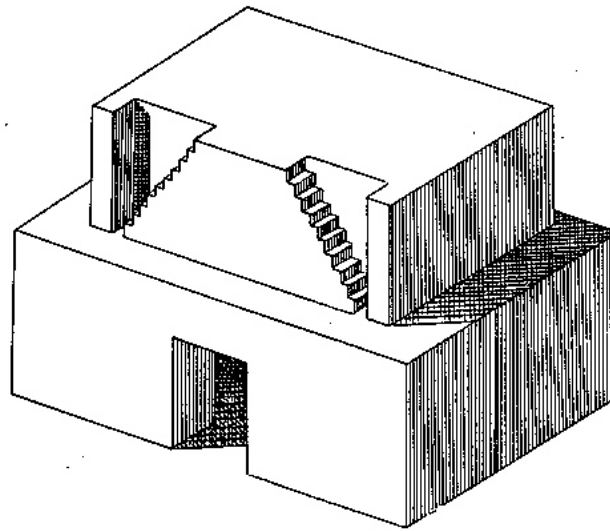

Figure 1.3: Reconstruction of Ahaz's Roof Chamber.

³⁵ The drawings that follow are Yadin's.

The Cairo model was small enough that it could be adjusted to be directly in line with the sun, no matter the time of year.³⁶ A permanent fixture on Ahaz's roof would not have allowed for this. It may be that the clock was smaller than Yadin suggests and movable.

The text of Isaiah 38:8 in LXX, which is the fullest, gives some clues as to how the clock may have worked. It reads as follows:

[ιδου εγω στρεφω]³⁷ την σκιαν των αναβαθμων ους κατεβη ο ηλιος το υς δεκα αναβαθμους του οικου του πατρος σου αποστρεψω τον ηλιον τους δεκα αναβαθμους και ανεβη ο ηλιος τους δεκα αναβαθμους ους κατεβη η σκια.

“Behold! I shall bring the shadow of the steps, the ten steps of the house of your father that the sun went down. I shall bring back the sun the ten steps.” And the sun went up the ten steps that the shadow went down.³⁸

The account provides us with several pieces of information. First, after Yahweh says that he will make the sun *go back*, the sun *goes up*. In other words, the sun had been setting, but it is made to return to a higher place in the sky. So the story takes place late in the day, towards evening. Second, we are told that, as the sun went back, the shadow descended the steps. This would mean that in normal time, as the sun began to set, the shadow would ascend the steps. As it moved over them, it would create more light and less shadow, so the shadow must have increased in size as the sun moved down the steps.

This fixes the place of the object creating the shadow. It must be at the bottom of the stairs, and high enough to create a shadow over all of the steps as the sun sets.

³⁶ Clagett, *Ancient Egyptian Science*, 93.

³⁷ The opening words are missing in the major LXX manuscripts, but are restored here from variant manuscripts in conformity with MT.

Yadin's reconstruction seems the most appropriate to fit the description (see Figure 1.4).

Third, we are told that there are ten steps. If the clock measured the movement of the sun throughout the entire day, we must presume there are ten steps on the other side as well.

The stairway would have been running east-west.

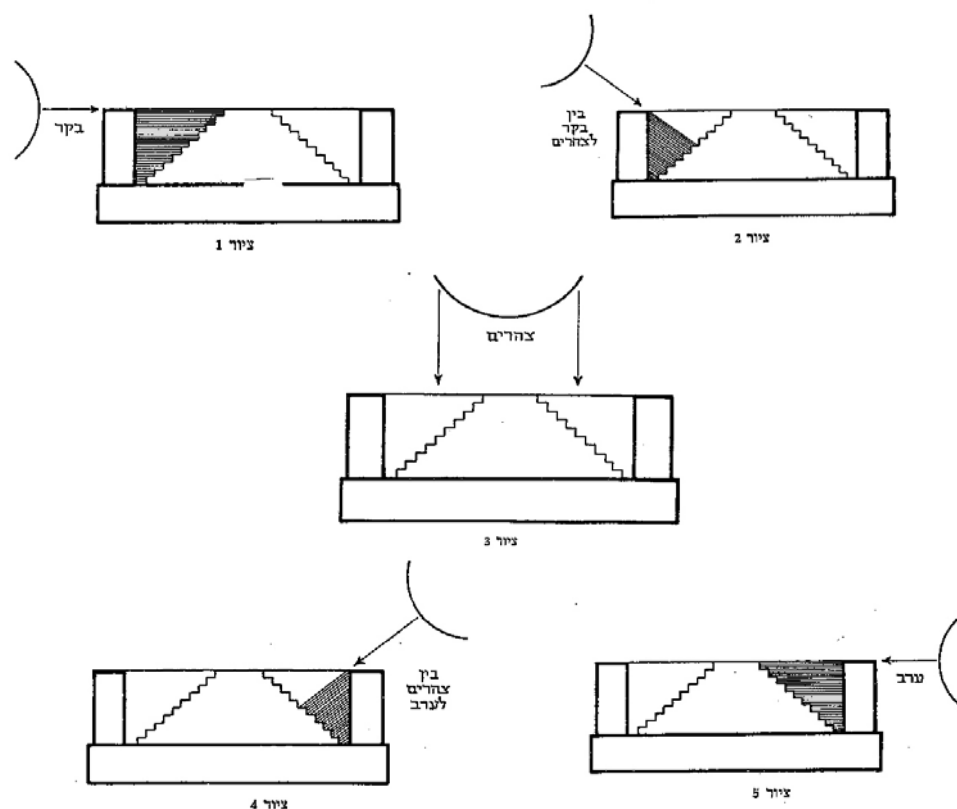

Figure 1.4: The Shadow Created on the Steps According to the Sun's Position.

Each step would represent a division of time. Ten steps on one side for the first half of the day (shadow moving down), and ten on the other for the second half of the day

³⁸ For a discussion of the textual history of this passage, see Iwry, "The Qumran Isaiah and the End of the Dial of Ahaz," 32-33.

(shadow moving up), indicate twenty units total. Keep in mind that this would be for daylight time only. Each step would represent approximately 36 minutes, that is, at times of the year when daytime and nighttime were equal, but would have been shorter during the winter and longer during the summer, as in the case of Egyptian shadow clocks. A division of the daytime into 20 units is unattested in the sources of any other ancient culture. If so, we may have here a uniquely Judahite clock. Alternately, we might suppose that it would take some time after sunrise for the shadow to drop the first step on the eastern stairway. In early Egyptian flat-surfaced shadow clocks, for example, it took two hours for the shadow to reach the first mark.³⁹ Since the clock seems to be based on an Egyptian model, we might surmise that it was an hour after sunrise before the shadow began to move (the equivalent of two steps), and likewise an hour before sunset when the shadow reached the top of the steps on the other side, twelve units on one side and twelve on the other, thus suggesting a daytime divided into 24 parts in harmony with the Egyptian 12-hour system. However, the step clock appears to have been different. The Cairo model has a number of steps equal to the number of hours in the Egyptian daytime (12), so it is probable that the Ahaz clock, if the same type of step-clock, had a number of steps that equaled the number of hours in the day (20).

C. The Month as a Unit of Measurement

1. The Hebrew Words for Month

There are two words in Hebrew that can mean “month.” One, חֹדֶשׁ, is a derivative of the word חָדַר (“moon”), which comes from a root meaning “to wander, travel,” and no

³⁹ Claggett, *Ancient Egyptian Science*, 85-86.

doubt is meant to evoke the thought of the moon as a wanderer or traveler.⁴⁰ It is the term of choice in the Gezer Calendar, in Phoenician inscriptions, and in the Ugaritic texts.⁴¹ The word is not used frequently in the Bible. It occurs 6 times in the Deuteronomistic History, three of which are in the citation of Phoenician month names (1 Kings 6:37, 38; 8:2), once in the blessing of Moses (Deut 33:14), once in the Deuteronomic Code (Deut 21:13), and once in reference to the length of the reign of an Israelite king (2 Ki 15:13). It occurs once in J (Exod 2:2), four times in the poetry of Job (3:6; 7:3; 29:2; 39:2), and once in the Book of Zechariah (11:8). The second term, שִׁטָּה, appears 44 times and is used by all of the major sources. It comes from a root meaning “new,” and no doubt is meant to evoke the thought of the rebirth of the moon at the beginning of each month.⁴²

2. The Naming and Numbering of Months

Months in the Bible are rarely named. Exceptions are found chiefly in the accounts of Solomon’s building projects (1 Kings 6:1, 37-38; 8:1), where the months Ziv, Bul, and Ethanim are mentioned. Two of these names, Bul and Ethanim appear in Phoenician inscriptions.⁴³ Because the month names in 1 Kings are limited to this context, it is quite possible that the accounts are based, at least partially, on Phoenician records or on contracts with the Phoenicians (King Hiram of Tyre assisted King Solomon in these construction projects). It is therefore not certain that the Israelites employed these

⁴⁰ R. E. Clements, "ירח," in *Theological Dictionary of the Old Testament*, ed. G.J. Botterweck et al. (Grand Rapids: Eerdmans, 1990) VI: 355-62.

⁴¹ Ibid., 356.

⁴² J. L. North, "חדש," in *Theological Dictionary of the Old Testament*, ed. G.J. Botterweck et al. (Grand Rapids: Eerdmans, 1977) IV: 225-44.

⁴³ Mark E. Cohen, *The Cultic Calendars of the Ancient Near East* (Bethesda, Md.: CDL Press, 1993), 384-85.

names on a regular basis. On the other hand, the month name Abib (not yet established as Canaanite) is attested in the law codes of E (Exod 13:4; 23:15), J (Exod 34:18), and Dtr (Deut 16:1), so there is reason to believe that this was a name commonly used in Israel in early times. Although some have argued that Abib is no month name at all, but rather a descriptor of some agricultural or seasonal event,⁴⁴ Abib has no features that distinguish it from other month names. Many months of the ancient Near Eastern calendars were named after agricultural or seasonal events and sometimes carry the definite article (e.g., “the month of the Ethanim” in 1 Ki 8:2).⁴⁵ It therefore seems likely that the Israelites did name their months at one time.⁴⁶

The custom of referring to months by number is evident in both P and Dtr. While monthly references permeate the priestly text, the Deuteronomistic History contains month references only in its final chapter, and in 1 Kings 6:1, 38 and 8:2. The last chapter of the DH was written during the exile. The month references in 1 Kings 6 and 8 also contain month *names*, and the numbered months are marked off by the independent pronoun שׁוֹמֵר, an indication that they are glosses. The similar use of שׁוֹמֵר in 2 Kings 25:8

⁴⁴ E.g., F.X. Kugler, *Von Moses bis Paulus: Forschungen zur Geschichte Israels* (Münster: Verlag der Aschendorffschen Verlagsbuchhandlung, 1922), 12-17, Jan A. Wagenaar, *Origin and Transformation of the Ancient Israelite Festival Calendar* (Wiesbaden: Harrassowitz Verlag, 2005), 25-31. Wagenaar argues that use of the term שׁוֹמֵר for “month” is a late development and that the word meant “season” in the pre-exilic period. He therefore concludes that Abib is not a month name. However, he dismisses the many instances in which pre-exilic authors clearly use the word שׁוֹמֵר to mean “month” (e.g., Gen 38:24; 1 Sam 27:7; 2 Sam 24:8; 1 Ki 5:7 [4:27]; 2 Ki 23:31) and instead supports his understanding of the word with a single passage in Jeremiah (2:23-24) in which שׁוֹמֵר appears to mean something like “season.”

⁴⁵ See Jeremy Hughes, *Secrets of the Times: Myth and History in Biblical Chronology*, ed. D.J.A. Clines and P. R. Davies, *Journal for the Study of the Old Testament Supplement Series*, vol. 66 (Sheffield: JSOT Press, 1990), 161.

⁴⁶ Auerbach draws attention to an interesting passage in Exod 9:31-32, which appears to name two other Israelite months: Gibeol and Aphilot (E Auerbach, “Die babylonische Datierung im Pentateuch und das Alter des Priester-Kodex,” *Vetus Testamentum* 2 [1952]: 334-35). Like Abib, these are unattested as month names outside the Bible.

raises the possibility that the glosses in 1 Kings 6 and 8 were added by the reviser of the DH during the exile.

If P is pre-exilic (and the evidence is strong that it is), it is the only text that demonstrates a pre-exilic usage of numbered months. However, some priestly data were contributed by the Redactor in later times. Is it possible to separate P chronological data from R chronological data in order to determine who numbered months and who did not?

When the priestly texts provide dates with reference to months, they do so for two purposes. One is to specify the times at which rituals are to be performed; the other is to date events in the narrative. For the reader's convenience, all 31 of these references in the priestly texts are divided according to purpose and listed in two columns below:

Table 1.1: Priestly Dates that Include Months

Dates of Yearly Rituals	Dates of Historical Events
Sheep taken for Passover: 1/10-1/14 (Exod 12:2,3,6)	Beginning of Flood: 2/17 in the 600 th year of Noah's life (Gen 7:11)
Eating of unfermented bread: 1/14-1/21 (Exod 12:18)	Ark rests on Mt. Ararat: 7/17 in the 600 th year of Noah's life (Gen 8:4)
Day of Atonement: 7/10 (Lev 16:29)	Tops of mountains appear: 10/1 in the 600 th year of Noah's life (Gen 8:5)
Passover: 1/14 (Lev 23:5)	Water is drained from the ground: 1/1 in the 601 st year of Noah's life (Gen 8:13)
Festival of Unfermented Cakes begins: 1/15 (Lev 23:6)	The earth is dried and Noah leaves ark: 2/27 in the 601 st year of Noah's life (Gen 8:14)
New Year's observance: 7/1 (Lev 23:24)	Israelites come to wilderness of Sin: 2/15 after leaving Egypt (Exod 16:1)
Day of Atonement: 7/9-7/10 (Lev 23:27,32)	Israelites come to Sinai: 3 rd month after leaving Egypt (Exod 19:1)
Festival of Booths: 7/15-7/21 (Lev 23:39,41)	Tabernacle set up: 1/1 in 2 nd year after leaving Egypt (Exod 40:2,17)
Sounding of horn in Jubilee year: 7/10 (Lev 25:9)	Census taken: 2/1 in 2 nd year after leaving Egypt (Num 1:1,18)

Table 1.1 continued	
Dates of Yearly Rituals	Dates of Historical Events
Make-up Passover: 2/14 (Num 9:3,5,11)	God institutes Make-up Passover: 1 st month in 2 nd year after leaving Egypt (Num 9:1)
Passover: 1/14 (Num 28:16)	Israelites leave Sinai: 2/20 in 2 nd year after leaving Egypt (Num 10:11)
Festival of Unfermented Cakes: 1/15-1/21 (Num 28:17)	Israelites come to Qadesh in Zin and Miriam dies: 1 st month [in 3 rd year?] after leaving Egypt (Num 20:1)
New Year's observance: 7/1 (Num 29:1)	Israelites leave Egypt: 1/15 (Num 33:3)
Day of Atonement: 7/10 (Num 29:7)	Aaron dies: 5/1 in the 40 th year after leaving Egypt (Num 33:38)
Festival of Booths: 7/15-7/21 (Num 29:12)	Moses delivers law on plains of Moab: 11/1 in the 40 th year after leaving Egypt (Deut 1:3-4)
	Israelites cross the Jordan: 1/10 [in the 41 st year?] after leaving Egypt (Josh 4:19)

The ritual schedule is provided three times in the priestly material, once in P proper (first part of the year in Exod 12, second part in Lev 16, and a supplement in Num 9), once in the Holiness Code (an update of P?)(Lev 23, 25), and once in R (Num 28, 29). The contents of Exodus 12 and Lev 16 are likely to be pre-exilic, and the months are numbered.

When it comes to the actual dating of historical events, however, we cannot be certain of preexilic practice among the Aaronid priests. There appears to be unity of authorship in the second column. Someone is clearly interested in laying out a comprehensive chronology of the wilderness events, and the Flood chronology exhibits some of the same characteristics. Textual analysis has shown that the list of the Wilderness Stations of Israel's journeys (Num 33) probably was incorporated into the Torah by the Redactor. R used this list to organize the stories he combined, and he set

twelve station headings within the newly-formed narrative to coincide with the list.⁴⁷ Two important dates are included in Numbers 33, the date that the Israelites left Egypt, and the date of Aaron's death. Four of the station headings within the wilderness narrative *also contain dates*, (Exod 16:1; 19:1-2; Num 10:11-12; 20:1-2), so they are likely redactorial as well (all are in the right-hand column in the table above).⁴⁸ If six of the nine wilderness dates in the table are R's, it makes little sense to assign the other three (Exod 40:2, 17; Num 1:1, 18; 9:1) to P. It appears R is responsible for the entire chronology. Regarding the date found in Deuteronomy (1:3-4), it appears likewise to be a part of R's wilderness chronology, because it continues to date events by the Exodus, follows precisely six months after the previous date (suggesting a connection between the two), and makes an effort to include the D speeches on the plains of Moab (absent in P) in the wilderness journey (cf. Num 33:48-49). R, not the author of P, had knowledge of the D material. Moreover, Deuteronomy 1:3-4 is clearly an intrusion in the D text. I would venture to say that the date at Josh 4:19 is also by R, because it is the final (and only other) date in the wilderness trek (the crossing of the Jordan would be the natural terminal point), and the editor wants to make it clear that the Israelites got to the other side by the tenth of the first month, so that they could observe the ritual of Exodus 12:2-6 [P].

That the Flood chronology also derives from R makes sense, as it exhibits the same characteristics of the rest of the chronology. The dates having to do with the flood stand out as very specific, naming both the month and the day that an event takes place:

⁴⁷ For the evidence, see Cross, *CMHE*, 308-17. Cross, however, while demonstrating a priestly redactor, does not distinguish between P and R.

In the 600th year of Noah's life, in the 2nd month, on the 17th day of the month, on this day, all the springs of the great deep were burst, and the gates of the skies were opened (Genesis 7:11).

And the ark came to rest, in the 7th month, on the 17th day of the month, on the mountains of Ararat. And the water lessened until the 10th month. In the 10th, on the first of the month, the tops of the mountains appeared (Gen 8:4-5).

And it came to be, in the 601st year of Noah's life, in the first month, on the first of the month, that the water dried from on the earth (Genesis 8:13-14).

This specific form of dating can be found elsewhere in the Torah *only* in R's wilderness chronology. Note that the expression בַּיּוֹם הַזֶּה in Genesis 7:11 appears also in Exodus 19:1 [R].

Although P's month references are limited to the ritual calendar, they are a clear indication that, at the very least, the priests began numbering months sometime in the pre-exilic period. It may be that they were the first to find the Canaanite month names problematic. We cannot safely assume this convention began earlier than the late eighth century BCE (that is, prior to the fall of the northern kingdom of Israel).

3. When Does the Month Begin and End?

In the preparation of a calendar, a choice needs to be made whether to count actual synodic months based on observation of the moon, in which case the lengths of months will fluctuate, or whether to arbitrarily assign a certain number of days to a month, regardless of the position of the moon (as we do in our calendar), in which case

⁴⁸ It might be argued that the headings could be composite and therefore the dates might not be from R, but

the lengths of the month will remain constant. The question is: what did the ancient Israelites do?

It has often been argued that the very name שָׁרָא for a month makes it clear that the month is based on the observation of the new moon.⁴⁹ However, we should be careful not to put too much emphasis on etymology. The word “month” in any language is related to the word for moon, but not all months are measured by observation of the moon. Even if originally a month denoted the passage of the moon, we cannot assume it always did.⁵⁰ Nevertheless, more substantial pieces of evidence indicating that it was customary to keep track of the phases of the moon in ancient Israel exist. These are the references to new-moon celebrations, often alongside Sabbath observances, in some of the books of the earlier prophets, both northern and southern (Amos 8:5; Hosea 2:13[11]; Isaiah 1:13), in the Deuteronomistic History (1 Sam 20:5, 24; 2 Kings 4:23), and in the Psalms (Ps 81:4). The association of these observances with activities of kings suggests that the observations of the moon were connected with the civil calendar. P, too, appears to assume that the moon was watched to keep track of time when it states that, as one of the luminaries, the moon’s primary purpose is to mark time (Gen 1:14).⁵¹ As shown below, the priests probably had their own unique calendar. The implication of Genesis

their presence in the headings is difficult to ignore.

⁴⁹ See, e.g. Sigmund Mowinckel, *Zum israelitischen Neujahr und zur Deutung der Thronbesteigungspsalmen* (Oslo: Jacob Dybwad, 1952), 22, Solomon Gandz, "The Calendar of Ancient Israel," *Homenaje a Millás Vallicrosa I* (1954): 630.

⁵⁰ In Egypt, for example, the hieroglyph for “month” was written with a crescent moon, even in the civil calendar, which had a set length for the month, regardless of the waxing and waning of the moon (Clagett, *Ancient Egyptian Science*, 7). See also Sacha Stern, *Calendar and Community* (Oxford: Oxford University Press, 2001), 3.

⁵¹ מועדים, often translated “seasons” refers more generally to “appointed times.”

1:14, then, is that the liturgical calendar, like the civil one, was based on observation of the moon.

On the other hand, evidence could be cited to demonstrate that months may have been assigned a set number of days, regardless of the actual phases of the moon. In the Flood narrative of Genesis, the priestly chronology informs us that five months separated the beginning of the Flood and the landing of the ark on Mt. Ararat, and that this period comprised 150 days (Gen 7:11; 8:3-4). The clear inference is that each month lasted an even 30 days. In a system in which direct observation of the moon determined the length of months, this could never happen. This schematic representation of the months is similar to that found in Daniel (12:7, 11), in which 3½ years is equated with 1,290 days (42 months of precisely 30 days). These figures simply may be idealized round numbers,⁵² but even if not, the Flood chronology was created by the Redactor of the Primary History (see above) and cannot therefore be used as evidence of pre-exilic custom.

When a calendar is intended to measure the actual length of months (i.e., the course of the moon), rather than create an arbitrary length for convenience, the most useful phenomena to observe are the moon's phases. A month is the interval of time between two successive observations of the same phenomenon. Since this period fluctuates slightly with no apparent pattern, there would have been little opportunity for prediction. Conjunction (when the sun, earth, and moon are in line) is the natural line of

⁵² The Babylonians, who practiced intercalation, also had this custom. See Gandz, "The Calendar of Ancient Israel," 623-46.

demarcation of the synodic month.⁵³ A common beginning point for a month was the evening in which the crescent first became visible. The Mesopotamians and Greeks counted months this way, because their days began at sunset.⁵⁴ The Egyptian lunar calendar, both the earlier and the later form, seems to have marked the months by the last visibility of the crescent in the morning.⁵⁵ This makes sense, since the Egyptian day began at sunrise. (In other words, we should expect the beginning of a month to coincide with the beginning of a new day.) Because the Israelites followed the Egyptian practice of counting their days from sunrise, it is likely that, if they did count the months by observing the moon, they would have marked the months by morning observation rather than evening observation.

The synodic month averages about 29 ½ days (+/- 13 hours), so in a calendar a lunar month can be only 29 or 30 days—never more and never less. According to the Egyptian system, if the crescent were not visible in the eastern sky just before sunrise on the morning of the 30th day of any given month, that day would be the first of the new month (the length of the preceding month would be determined to have been 29 days). Sometimes poor visibility would make it impossible to tell, so the month might last another day, but the month would end at 30 days no matter what the atmospheric conditions were the next morning. If the observers made an error (counting a 29-day

⁵³ See the helpful discussion in Samuel, *Greek and Roman Chronology*, 5-10. The month can also be measured by its position in reference to a star, but the length of time the moon takes to travel around the earth and back to the same place (27 1/3 days—a sidereal month) is actually two days shorter than a synodic month and not commonly used for calendar purposes.

⁵⁴ F. Rochberg-Halton, "Calendars, Ancient Near East," in *Anchor Bible Dictionary*, ed. D.N. Freedman (Garden City: Doubleday, 1992) I: 810; Samuel, *Greek and Roman Chronology*, 14.

⁵⁵ Parker, *The Calendars of Ancient Egypt*, 9-23, Richard A. Parker, "The Beginning of the Lunar Month in Ancient Egypt," *Journal of Near Eastern Studies* 29.4 (1970): 217-20, Clagett, *Ancient Egyptian Science*, 22-28.

month as 30 days), it would automatically be corrected by the next clear observation of the crescent (so sometimes a 29-day month might end up being 28 days as a result).

4. Measurable Divisions of the Month

Apart from being divided into days, months apparently were not divided into anything else for calendar purposes in ancient Israel. The week, a convenient short period of time greater in length than a day, and lesser in length than a month, is not a natural unit of time. Four weeks (28 days) come close to the length of a synodic month (29 ½ days), but not close enough to maintain accordance between weeks and months over any lengthy period of time. The ancient Egyptians had a 10-day week, arbitrarily created to fit neatly into the 30-day month of its civil solar calendar.⁵⁶ The 7-day week, though attested earliest among the Israelites, nevertheless was based on a number commonly regarded as significant or sacred in many ancient Near Eastern cultures and probably having its origin in the observation that seven heavenly bodies (sun, moon, Mercury, Venus, Mars, Jupiter, and Saturn) were known to move against the fixed background of the stars. The organization of days into groups of seven, in honor of these heavenly bodies, was convenient.⁵⁷ By the first century BCE the days of the week would be named after these bodies.

On the other hand, it is possible that 7-day weeks were based on the phases of the moon. In the *Enuma Elish*, when Marduk creates the moon “to mark out the days,” he says:

⁵⁶ Clagett, *Ancient Egyptian Science*, 49-50.

⁵⁷ Solomon Gandz, "The Origin of the Planetary Week or the Planetary Week in Hebrew Literature," in *Proceedings of the American Academy for Jewish Research* (1949) XVIII: 213-54.

At the month's very start, rising over the land,
 You shall have luminous horns to signify six days,
 On the seventh day reaching a half-crown.
 So shall the fifteen-day period be like one another-two halves for each month.
 When the sun overtakes you at the base of heaven,
 Diminish your crown and retrogress in light.
 At the time of disappearance approach the course of the sun,
 And on the thirtieth you shall again stand in opposition to the sun. (V:12-22)

In this scheme, the week plays an important role. The first seven days cover the period from the new moon to the half-moon. Another period of seven days covers the period from the half-moon to the full moon. Day 15 is the middle of the month. Then the reverse happens. Seven days cover the period from the full moon to the half-moon, and seven days the half-moon to the new. Day 30 may be the last day of the month, or the first day of the next. To be sure, this delineation of the days may simply be an attempt to harmonize the week with a lunar month, but it is also possible that the idea of a 7-day week came from this scheme.

The word for week in Hebrew is שבוע, which comes from the word for “seven;” it appears infrequently in the Bible.⁵⁸ Most often we find it as part of the expression “Festival of Weeks,” a feast that received its name because it occurred at the culmination of a series of seven weeks commencing at harvest.⁵⁹ The earliest reference to this festival is in J’s Decalogue (Exod 34:22). We also find it in the Deuteronomic Code (Deut 16:9-12) and in the priestly laws, but without the name (Lev 23:15-16). Interestingly, the only time we find weeks being *counted* in the Bible is in conjunction with the Festival of

⁵⁸ Brin, *Concept of Time*, 167-68, Eckart Otto, “שבוע,” in *Theological Dictionary of the Old Testament*, ed. G.J. Botterweck et al (Grand Rapids: Eerdmans, 2005) XIV: 336-67.

⁵⁹ James C. VanderKam, “Weeks, Feast of,” in *Anchor Bible Dictionary VI*, ed. D.N. Freedman (New York: Doubleday, 1992): 895-97.

Weeks. Only in J do we find the word “week” used in a secular sense (Gen 29:27-28). Nevertheless, because of the Sabbath observance, the week is an important part of Israelite society, usually called a period of “seven days” rather than “one week.” Though not often employed this way, the word for Sabbath (שַׁבָּת) is sometimes used by P as a parallel designation for a week (e.g., Lev 23:15). The days of the week are of particular interest to P and are usually numbered. An apparent innovation of P is not only to organize *days* into weeks, but *years* into weeks as well (Lev 25:8), although there is a possible instance of this usage in J (Gen 29:26-27).

D. The Year as a Unit of Measurement

1. The Hebrew Word for Year

The Hebrew word for year, שָׁנָה, comes from a root meaning “to change” or “to repeat.”⁶⁰ The implication is that the year is a revolution of time. Ancient farmers were well aware of the change in seasons, and such knowledge would have governed their idea of what constituted a year. The annual cycle marked by seasons is assumed in many pre-exilic texts (e.g., Gen 8:22; 17:21). More exact observation of the movement of the sun revealed the times of the year when the period of daylight and period of night were equal (the equinoxes on about September 22 and March 20), as well as the days when the daylight was shortest (December 21) and longest (June 21) (the solstices).⁶¹ The length of

⁶⁰ Jack Finegan, *Handbook of Biblical Chronology*, 2nd ed. (Peabody: Hendrickson, 1998), 16.

⁶¹ The equinoxes occur when the sun crosses the equator and equally irradiates the north and south poles, and the solstices when the sun seems to stand still as it is traveling northward and then again as it is traveling southward. Another way of calculating the equinoxes and solstices is by measuring the sun’s shadow.

the tropical year therefore was well known among the ancients to be approximately 365 days.⁶²

There is no natural beginning point of a year (i.e., a place where the sun naturally begins its journey), so ancient societies would establish the first day of a year as they preferred. This could be done by selecting a seasonal change, an important anniversary date, or a natural astronomical phenomenon. Calendars that took into account the phases of the moon tended to choose the latter (the beginning of a natural month), and calendars that disregarded the moon's phases would usually pick an arbitrary date. Agricultural calendars tended to choose seasonal occurrences as starting points for the year. A single society might have more than one sort of calendar in use. Assyria had at least two calendars operating at the same time (before its adoption of the Babylonian calendar), one solar and one lunar. The solar year began around the time of the autumnal equinox. The lunar year began at a different point in the solar year each year.⁶³ Egypt had three calendars. The civil year was 365 days long, consisting of 12 months of 30 days, plus 5 extra days. This calendar was $\frac{1}{4}$ of a day short of a solar year and so each year began $\frac{1}{4}$ of a day earlier than it had the previous year. The agricultural year always began in the summer at the onset of the Nile inundation and was linked through intercalation to the rising of the Dog Star Sothis (Sirius). The religious calendar was lunar and used for fixing festival days but was linked to the solar year, so that it began in the summer as well.⁶⁴

⁶² The Egyptians were counting a 365-day year as early as the third millennium BCE. See Parker, *The Calendars of Ancient Egypt*. In the Bible, the number of years in the lifespan of Enoch (Gen 5:23) may be a symbolic figure based on the length of the tropical year.

⁶³ Cohen, *The Cultic Calendars of the Ancient Near East*, 237-47.

⁶⁴ S.R.K. Glanville, *The Legacy of Egypt* (London: Oxford, 1942), 1-9.

2. When Does the Year Begin and End?

a. The Agricultural Year

That farmers saw the year generally as comprising two main parts, seedtime (winter) and harvest (summer), is seen in J, which is roughly contemporaneous with the Gezer Calendar (Gen 8:22; 45:6; Exod 34:21), and in E's Covenant Code (Exod 23:10). Seedtime would have run from mid-November to mid-April, and harvest (almost twice as long) from mid-April to mid-November.

Table 1.2: Agricultural Activity in Modern Israel
(Based on Borowski, pp. 70-71)

	Nov	Dec	Jan	Feb	Mar	Apr	May	Jun	Jul	Aug	Sep	Oct
Wheat	Sow	Sow					Reap					
Barley	Sow	Sow				Reap						
Oats	Sow	Sow					Reap					
Vetch	Sow	Sow				Reap	Reap					
Flax		Sow							Reap			
Peas		Sow	Sow			Reap	Reap					
Lentils		Sow				Reap	Reap					
Vegetables			Sow	Sow	Sow							
Chickpeas				Sow				Reap				
Millet					Sow	Sow			Reap	Reap		
Sesame						Sow			Reap			
Grapes								Reap	Reap	Reap	Reap	
Figs										Reap	Reap	
Pomegranates										Reap	Reap	
Olives	Reap										Reap	Reap

That the agricultural year began with the winter planting and concluded well into the autumn is confirmed by the order of the festivals in the early codes preserved by both E (Exod 23:16) and J (Exod 34:22), which place the Festival of Gathering **בְּצֹאת הַשָּׂנָה**

(“at the end of the year”) and תְּקִיֶּפֶת הַשָּׁנָה (“at the turn of the year”), respectively.⁶⁵ In J, Isaac is said to have planted and harvested in the same year (Gen 26:12), an impossibility if the year began with the harvest. Jeremiah, equating the harvest with the summer (Jer 8:20; cf. also Amos 8:1-2), implies that the second of the two seasons was over (and therefore the year itself) when the harvest was over. Moreover, the legislation that the land was to lie fallow every 7th year (Exod 23:10-11; Lev 25:1-22 [P]) can hardly be understood to occur in anything but an agricultural year, divided between seedtime and harvest.⁶⁶

The longer period in the agricultural year, harvest (7-8 months), is approximately twice as long as planting time (4-5 months) and in some sources is separated into two equal parts: threshing time and vintage (Lev 26:5 [P]; Am 9:13), so that, for the farmer, the year would be divided into three equal seasons of four months, the first of which, the

⁶⁵ That these two expressions are synonymous is confirmed by the fact that the two passages from which they come are clearly parallel, and there is no question that בְּצֵאת הַשָּׁנָה refers to the end of the year. See E. Kutsch, "am Ende des Jahres': Zur Datierung des israelitischen Herbstfestes in Ex 23,16," *Zeitschrift für die alttestamentliche Wissenschaft* 83 (1971): 15-21; see also Wagenaar, *Origin and Transformation*, 9-11. Wagenaar makes the valid point that הַשָּׁנָה may refer, not to the agricultural year, but to a civil year and suggests that the reason Exodus 34 (which appears to be the later version) reads תְּקִיֶּפֶת הַשָּׁנָה is because the civil year no longer ended in the autumn and the earlier expression בְּצֵאת הַשָּׁנָה was no longer appropriate (Wagenaar, *Origin and Transformation*, 11, 21-22). This is certainly possible. The civil calendar and any changes made to it during the monarchic period will be investigated below.

⁶⁶ Hughes (Hughes, *Secrets of the Times*, 168) argues, following Morgenstern (Morganstern, "Supplementary Studies in the Calendars of Ancient Israel," 83-86), that the Sabbath year reflected in Leviticus 25 begins in the spring, because, in vv 20-22, God says he will ensure that the harvest of the 6th year will produce enough food for three years (6th, 7th, and 8th). In an autumn-based calendar, there would be no need to have produce from the 6th year feed people in the 8th, because the harvest of the eighth year would provide food for the eighth year. In a spring-based calendar, however, the harvest of the 6th year would *commence* a new year, rather than end one, and so, although there would be planting at the conclusion of the 6th year, no one would be permitted to harvest the crops in the beginning of the 7th. So the 6th year harvest would provide, not only for the 6th year, but also the 7th and the 8th (for there would be no harvest at the beginning of the 8th year). However, to assume that there would be planting in the 6th year with the full knowledge that those crops would not be harvested is ludicrous. Why would the farmers go through all that work for nothing? The autumn-based calendar presents no problem to the understanding of these verses. The produce of the 6th year would provide (1) for the second half of the 6th year, (2) for the entire 7th year, and (3) for the first half of the 8th year. The three years are counted inclusively.

planting season, would have commenced around November 15. A case has been made that the plural form of the Hebrew word for day (יָמִים) may be used at times to refer to a four-month season.⁶⁷ In support of this position, Judges 19:2 and 1 Sam 27:7 are cited, both of which appear to contain an explicative gloss (“four months”) for the word יָמִים. This understanding makes good sense in many biblical passages (e.g., Gen 1:14; 24:55; 40:4; Lev 25:29; Num 9:22; Jud 17:10; 1 Sam 29:3; 2 Sam 14:26; Isa 32:10; 2 Chron 21:15, 19). Such a division into three seasons of four months each, based on climatic and agricultural factors, was the custom on Egypt.⁶⁸ The Egyptian seasons were: 1) *peret* (“coming forth”), when the planting and tilling of crops took place, 2) *schemu* (“deficiency”), the time of harvest and the dropping of the waters of the Nile, and 3) *akhet* (“indundation”), when the Nile rose and overflowed the fields. The Israelite seasons would not be exactly parallel, but there is nothing equivalent to the Nile-based agriculture in the Levant, and any system of seasons would naturally reflect the climatic and agricultural conditions found in a given locality.

Alternately, it has been suggested that the Israelite year was divided into four seasons of three months each.⁶⁹ Such a subdivision of the year is implied by the description of Solomon’s corvée system in the DH (1 Ki 5:27-28), in which three contingents of men are called up to work for one month, after which they receive two months off. Neat units of three months are therefore implied. This division into four seasons also appears to be reflected in Jephthah’s mourning rites, which are observed

⁶⁷ F.S. North, "Four-Month Seasons of the Hebrew Bible," *Vetus Testamentum* 11.4 (1961): 446-48.

⁶⁸ Clagett, *Ancient Egyptian Science*, 4-5.

⁶⁹ See Shemaryahu Talmon, "The Gezer Calendar and the Seasonal Cycle of Ancient Canaan," in *King, Cult and Calendar in Ancient Israel* (Jerusalem: Magness Press, 1963): 101.

four times in the year (Judges 11:40). However, these latter references do not appear to be connected with the agricultural year at all.

Another interesting expression, possibly related to the agricultural year, is תשובת השנה (“the return of the year”). It is likely an agricultural designation, because it is concerned with a change in seasons, and refers to the spring, when farmers have completed planting and when kings go to war (2 Sam 11:1; 1 Ki 20:22, 26). Now that it has been established that the agricultural year began in the early winter, it is clear that תשובת השנה does not refer to the time when the year ends and the next begins, but to the time when the year has reached its furthest point and begins its journey back.

With the knowledge that the agricultural year began around November 15, we can more readily make sense of the statement by the Deuteronomistic Historian that Jeroboam celebrated the Feast of Gathering “on the fifteenth day of the eighth month” (counting the months according to a spring-based calendar),⁷⁰ and lasting about a week (1 Kings 12:32-33). Whether this custom goes all the way back to Jeroboam cannot be verified, but the statement does reflect the Historian’s knowledge that northern Israel celebrated the end of the agricultural year precisely at the time I have argued it ended.⁷¹

⁷⁰ Parts of the Deuteronomistic History assume a spring-based calendar. See below.

⁷¹ It is sometimes asserted that crops in northern Israel matured slightly later than in Judah, and that this alone may account for the difference of one month between Israel’s and Judah’s harvest festival. However, the differences between north and south are somewhat exaggerated. In fact, there is a greater difference between Hebron and the Shephelah (both in the south) in the time of the maturation of the crops than there is between the Shephelah and the Valley of Jezreel (in the north) (see Oded Borowski, *Agriculture in Iron Age Israel* [Ann Arbor: University of Michigan, 1979], 66). It is very likely that the agricultural season in both the north and the south were approximately the same. A harvest festival in the eighth month would have suited both Israel’s and Judah’s agricultural season better than one in the seventh.

b. The Civil Year

The earliest evidence we have discovered for a description of the ancient Israelite year is some writing on a limestone slab that was found in 1908.⁷² The inscription is popularly known as the Gezer Calendar, although it is more accurately a list of agricultural activities arranged by months than it is a calendar. The document was written in the lowlands somewhere between 950 and 925 BCE and has been interpreted variously as an administrative document drawn up for the purpose of tax collections and as some kind of mnemonic ditty for children.⁷³ Whatever its purpose, the Gezer Calendar divides the year into one-month or two-month periods and assigns an agricultural activity to each one.

Its two months are [olive] harvest,
 Its two months are planting [grain],
 Its two months are late planting,
 Its month is grass-cropping,⁷⁴
 Its month is barley harvest,
 Its month is harvest and measuring,⁷⁵
 Its two months are grape harvesting,⁷⁶
 Its month is summer fruit.

⁷² Published by Robert A.S. Macalister, *The Excavation at Gezer*, vol. II (London: Palestine Exploration Fund, 1912), 24ff.

⁷³ William Foxwell Albright, "The Gezer Calendar," *Bulletin of the American Schools of Oriental Research* 92 (1943): 16-26, Talmon, "Gezer Calendar," 89-91.

⁷⁴ On the translation of פִּשְׁתָּהּ, see Talmon, "Gezer Calendar," 92-100, Borowski, *Agriculture*, 60.

⁷⁵ Reading the last word as וְכִיל; see Borowski, *Agriculture*, 60-61.

⁷⁶ On the translation of זֶמֶר, see *Ibid.*, 61.

The first thing to note is that the list does not begin at the beginning of planting season, but at the time the olive harvest commenced (late September, around the autumnal equinox). Had the months been arranged strictly according to the farmer's schedule, we would have found the olive harvest at the conclusion of the list, so that the eight months of harvest would have been together, and the four months of sowing would have headed the list.⁷⁷ Since the evidence points to an agricultural year beginning with planting season (end of autumn/beginning of winter), an independent, non-agricultural (i.e., civil) calendar must be influencing the order of months in the Gezer Calendar. This is not surprising, since the agricultural year, though meaningful to farmers, would have been far less important to scribes and administrators than the civil year. Comparable is the Sumerian "Farmer's Almanac," another document describing yearly agricultural activities, which coincides with the standard Mesopotamian year.⁷⁸

We cannot attribute this calendar to Canaanite influence. A civil calendar beginning in the autumn seems not to have been the Canaanite custom.⁷⁹ The attestation of Canaanite month names (Ziv, Bul, and Ethanim) in the accounts of Solomon's building projects (1 Kings 6:1, 37-38; 8:1) could be used to argue that the Israelites were using the Canaanite calendar in the days of Solomon, but since the month names appear in 1 Kings only, it is more likely that the accounts are based, at least partially, on Phoenician records. On the other hand, the spring month name Abib (corresponding to March/April), which appears in several places in the Bible, may be a Canaanite month

⁷⁷ It is difficult to agree with Clines' assertion that the beginning of the year for a farmer in ancient Palestine would be, not the time of planting, but the autumn, on the ground that it was "the most conspicuous transitional point in the seasonal year" (Clines, p.38). What makes it the most conspicuous transitional point for a farmer?

⁷⁸ Cohen, *The Cultic Calendars of the Ancient Near East*, 384.

name, although as yet it is unattested in other sources. However, P's statement that this month should now become the first of the months (Exod 12:2) makes it likely that it was not always so, and thus a calendar year beginning in the autumn would have preceded the one beginning in spring.⁸⁰

The Book of Jeremiah contains the earliest unambiguous references to a civil year beginning in the spring. In the account about Baruch's reading of Jeremiah's scroll to Jehoiakim (written sometime between 605 and the exile), the "ninth month" is clearly set in the wintertime, because the king is in his winter home and has a fire burning to keep him warm (36:22). Unfortunately, because we do not know precisely when this account was composed (it is entirely possible that it was written after the fall of Jerusalem), we cannot say for certain that the spring year was used in pre-exilic Judah. If the account were written prior to the fall of Jerusalem, it still would have been composed during the period of Babylonian suzerainty, when the Babylonian spring-based calendar would have had a great influence on Judah and therefore is not necessarily a piece of evidence reflective of traditional Judahite custom.

It is true that the Deuteronomistic History contains month references that suggest a spring-based year, but these occur only in three places:

1) *The final chapter of the History* (2 Kings 25). This, however, is an exilic addition and therefore cannot be used as evidence of preexilic practice.

⁷⁹ At least not at Ugarit, which appears to have begun its civil year in the spring (See *Ibid.*, 377-78).

⁸⁰ It is sometimes argued that expressions such as "autumn rain and spring rain" (note the order) are found in the pre-exilic edition of the DH and the early sections of the Book of Jeremiah (Deut 11:12, 14; Jer. 5:24) and that these imply a year beginning in the autumn. The idea is that a year beginning in spring would encourage the reverse expression, "spring rain and autumn rain." However, since there are not two rainy seasons in the Levant, but only one, which begins in the autumn and ends in early spring, it is highly

2) *The account of Solomon's building projects* (1 Kings 6:1, 38; 8:2). This account provides both actual month names *and* month numbers. The latter, which do indicate a spring-based year, are probably added by way of explanation. For example, it is stated that, in Solomon's reign, the ark of the covenant was brought to the Temple in the month of Ethanim, and then it is added that this was the seventh month (1 Kings 8:2). However, it would be a mistake to conclude that in Solomon's time, Ethanim was, in fact, the seventh month according to the calendar then in use. The historian apparently needed to add a gloss (marked off by the independent pronoun **וְ**) explaining to his readers that Ethanim corresponded to month seven because they were not familiar with the old month names. All we can say for sure is that in the *editor's* time, Ethanim corresponded to the seventh month. He was speaking in the context of his own time, and the month-numbering system that he used might not have corresponded to a regnal system at all. The same procedure is used in 2 Kings 25:8, which separates the notice of the month and day from Nebuchadnezzar's regnal datum with the independent pronoun **וְ**. The similarity of the glosses in 1 Kings 6 and 8 to the data in 2 Kings 25 suggests that both sets of glosses were added by the reviser of the DH in the exile. The month numbers therefore would not reflect preexilic custom.

3) *The account of Jeroboam's religious reforms* (1 Kings 12:32-33). In this last case, although it is entirely possible that Dtr¹ contained the references, it would be the only spot in the original DH that did. There is therefore a possibility that these references too are additions. The passage reads:

unlikely that the expression "spring rain and autumn rain" would ever be used, even in a spring-based calendar. Therefore, I do not see this as a valid argument for an autumnal calendar.

And Jeroboam made a festival **in the eighth month, on the fifteenth day of the month**, like the festival that was in Judah, and he offered upon the altar that he made in Bethel a sacrifice to the calves that he had made, and he put in attendance in Bethel the priests of the high places that he had made. So he offered upon the altar that he made in Bethel, **on the fifteenth day of the eighth month**, in the month he invented for himself, and he made a festival for the Israelites, and he offered upon the altar sacrificial smoke.

As in the case of Solomon's building projects, there is an original, though ambiguous, month reference ("the month he invented for himself") that may have needed further explication for a later audience. However, a version lacking the numbered month references would have read quite smoothly. Indeed the phrase, "on the fifteenth day of the eighth month, in the month he invented for himself," seems somewhat redundant. So we should at least acknowledge the possibility that the numbered month references are secondary and that Dtr¹ did not assume a spring-based civil calendar.

From this last passage we may conclude that there was a difference between Israel and Judah in the time of their observance of the harvest festivals. At the time the Deuteronomistic History was published (in the reign of Josiah), Judah was celebrating both the beginning of its civil year *and* the end of its agricultural year in the autumn (seventh month in a spring-based calendar). Although the text makes it seem as if Jeroboam was the innovator, placing the festival in the following month, if the agricultural year began in the winter, Jeroboam's practice actually appears to reflect *earlier* custom. It therefore seems more likely that the southerners were the innovators than the northerners. In other words, while at one time Judah's civil and agricultural

calendars were separate and independent, for convenience they appear to have attempted to make the two calendars coincide. Later on, they claimed originality.

c. The Liturgical Year

P's assertion that the spring month of Abib (Mar/Apr) should be the first of the months (Exod 12:2) clearly reveals when the priestly year began. The Paschal Offering and the Feast of Unleavened Bread (spring observances) begin the priestly calendar of holy days (Lev 23:4-8).

Yet P is clearly aware of other calendars, and even uses them on occasion. The Sabbath and Jubilee laws are based on the agricultural calendar, which begins the year with planting season (Lev 25). The proclamation of the Jubilee at the end of the civil New Year festival in the seventh month is clearly an accommodation of the civil year.⁸¹ These pieces of evidence indicate that P has knowledge of a harmonized civil and agricultural year. The holiday calendar from the Holiness Code, in fact, doubly insists (perhaps aware of northern custom) that the harvest Festival of Booths *must* be celebrated in the seventh month (Lev 23:39-41). A concentration of festivals in the seventh month, largely parallel to those in the first month, clearly shows a recognition of the calendric importance of the seventh month. None of P's festivals, however, either in the first or seventh month, can be considered a New Year's Day celebration.⁸²

⁸¹ The Jubilee is both an agricultural and a civil observance (see Hughes, *Secrets of the Times*, 167-68). On the preexilic date of the Jubilee, see Lisbeth S. Fried and D.N. Freedman, "Was the Jubilee Year Observed in Preexilic Judah?" in *Leviticus 23-27* (New York: Doubleday, 2001): 2257-70, Milgrom, *Leviticus 23-27*, 2241-48.

⁸² Propp, *Exodus 1-18*, 386-87, Milgrom, *Leviticus 23-27*, 2012-18.

d. The Regnal Year

So far it has been determined that the beginning of the civil year in Judah commenced in the autumn (Sept 15 or so), and that, at least in the early period, the year in northern Israel began at the same time. (We have not established, however, the beginning of the civil year in northern Israel after the kingdoms split.) It has also been demonstrated that the agricultural year in both kingdoms began two months later (Nov 15 or so). An agricultural year beginning late November remained the custom in Israel, but Judah pushed back the celebration of the new agricultural year to coincide with the civil year sometime prior to the time of Josiah. P's liturgical year began in the spring, but P still acknowledges the existence of a civil year beginning in the autumn. What effect do these conclusions have upon our understanding of the regnal year? We should not take it for granted that the regnal year and civil year coincided, but it is likely.

At Babylon and Aššur, the ritual of coronation and renewal of the king's sovereignty seems to have been associated with the New Year's festival and purification of the temple of Marduk.⁸³ Parallels between the Babylonian purgation of the temple in the spring, at the beginning of its civil year, and Israel's Yom Kippur in the autumn, at the beginning of its civil year, are readily apparent (cf. Ezek 45:18).⁸⁴ In Mesopotamia there apparently was a direct connection between the celebration of the assumption of

⁸³ See Henri Frankfort, *Kingship and the Gods* (Chicago: University of Chicago Press, 1948), 313, H. W. F. Saggs, *The Greatness that was Babylon* (New York: Mentor, 1968), 364, Thorkild Jacobsen, "Mesopotamian Gods and Pantheons," in *Toward the Image of Tammuz and Other Essays on Mesopotamian History and Culture*, ed. William L. Moran (Cambridge: Harvard University Press, 1970): 16-38, esp. 36-37, Baruch Halpern, *The Constitution of the Monarchy in Israel* (Chico, CA: Scholars Press, 1981), 51-61.

⁸⁴ Milgrom, *Leviticus 1-16*, 1067-71.

kingship by Marduk and that of the mortal king. We might presume a connection similarly between the liturgical psalms celebrating the enthronement of Yahweh (Psalms 47, 93, 95-100) and the enthronement of the Davidic king. Such a celebration is likely to have occurred during the autumnal New Year's festival, and late prophetic material appears to confirm this (e.g., Zech 14:16).⁸⁵

Independent of this argument, we might examine some other evidences of the regnal year. Of the two kingdoms, Judah leaves us with more clues. Most of the evidence comes from the period after the fall of the northern kingdom of Israel (c. 720). At first glance we might conclude that the clues unambiguously point to a spring-based calendar. One significant text is 2 Kings 25:8 (= Jer 52:12), which dates the destruction of Jerusalem's temple to the fifth month. Since we know from the Babylonian records that the city fell in the month of August, there is no doubt that, according to the system used here by the historian, the year began in the spring. Another significant text, the context of which is in the reign of King Jehoiakim, is Jeremiah 36:22 (mentioned earlier), which clearly places the "ninth month" in the wintertime. This piece of evidence also points to a system governed by a spring Regnal New Year.⁸⁶ However, these evidences are based on the assumption that the calendar by which the historian was dating these events was Judah's *regnal* calendar. We should be reluctant to put too much weight on these data. The historian's information does not always derive from government sources, and his

⁸⁵ For full discussions, see Sigmund Mowinckel, *Psalmenstudien*, vol. 1 (Amsterdam: P. Schippers, 1966), Halpern, *The Constitution of the Monarchy in Israel*, 61-109, C. L. Seow, *Myth, Drama, and the Politics of David's Dance* (Atlanta: Scholars Press, 1989), J. J. M. Roberts, "Mowinckel's Enthronement Festival: A Review," in *The Book of Psalms: Composition and Reception*, ed. Jr. P.W. Flint and PD. Miller (Leiden: Brill, 2005): 97-115.

⁸⁶ E.g., Gershon Galil, *The Chronology of the Kings of Israel and Judah*, Studies in the history and culture of the ancient Near East v. 9 (Leiden; New York: E.J. Brill, 1996), 9-10.

point of view shifts frequently. He may also speak on occasion (or even often) from the context of his own times. We thus are unable to use the datum at Jeremiah 36:22 as evidence that the beginning of the Regnal New Year in Judah in Jehoiakim's reign was in the spring. The most we can say is that, by the calendar to which the scribe himself was accustomed at the time of writing, the year began in the spring. That calendar may not have been, and, as we shall see, probably was not, the regnal calendar of Judah.

Evidence for a regnal year beginning in the autumn in the latter days of Judah is much stronger and relies on evidence deriving from pre-exilic sources. An autumnal Regnal New Year seems to be indicated by the data in 2 Kings 22 and 23, which place the beginning of King Josiah's temple reparations and religious reforms and the subsequent Passover celebration all within his eighteenth regnal year. Since the Passover would have fallen on the fourteenth day of the presumed first month, the assumption of a spring Regnal New Year would require us to believe that the work of the repair and all involved with it was accomplished in a two-week span. It is more reasonable to conclude that the repairs began prior to the first day of that month, in which case that month could not have been the first one of the year, and we would then have to posit that Josiah's eighteenth year began in the autumn.⁸⁷

We have additional indications of an autumn-based regnal year from the reign of Zedekiah. The historian's sources place the fall of Jerusalem in Zedekiah's eleventh year (2 Kings 25:2) and in Nebuchadnezzar of Babylon's nineteenth year (2 Kings 25:8). In the book of Jeremiah, in a description of events associated with the Babylonian siege,

⁸⁷ Argument also in Edwin R. Thiele, *The Mysterious Numbers of the Hebrew Kings* (Grand Rapids: Eerdmans, 1951, 1965, 1983), 29-30 (2nd ed.).

Baruch connects Zedekiah's tenth year with Nebuchadnezzar's eighteenth (Jeremiah 32:1). Seemingly, then, the regnal years of these two kings coincided exactly, and it is well known that Nebuchadnezzar's regnal years began in the spring, on the 1st day of Nisan.⁸⁸ However, additional data do not support this presumption and suggest that their regnal years merely overlapped in the summertime. Jeremiah 32 recounts the visit of Hanamel, Jeremiah's cousin, to Jeremiah in the court of the guard sometime after the defeat of Pharaoh Hophra's forces by the Babylonians and the resumption of Nebuchadnezzar's siege of Jerusalem. When was this? An oracle of Ezekiel, recounted in the third month of the eleventh year (by Babylonian reckoning) of the captivity of King Jehoiachin, mentions the defeat of the Egyptians as having happened recently, probably a few months before (Ezekiel 31). Jehoiachin's captivity began on the first day of the Babylonian year, Nisan of 597. Therefore the eleventh year of his captivity ran from Nisan 587 to Adar 586. Since Zedekiah was placed on the throne immediately after Jehoiachin, if his regnal years were counted from Nisan, then the years of his reign and the years of Jehoiachin's captivity would correspond precisely. However, if Zedekiah's eleventh year ran from Nisan 587 to Adar 586, it would coincide with Nebuchadnezzar's eighteenth year, not his nineteenth, as the data in 2 Kings 25 indicate. However, if Zedekiah began counting his reign in the autumn after the captivity began (597), his eleventh year would run from the autumn of 587 to the autumn of 586, and there would be an overlap with Nebuchadnezzar's eighteenth *and* nineteenth years. All of the chronological pieces would fall into place. It seems best, therefore, to understand the

⁸⁸ Francesca Rochberg, "Astronomy and Calendars in Ancient Mesopotamia," in *Civilizations of the Ancient Near East*, ed. Jack M. Sasson (Peabody: Hendricksons, 1995) III: 1931.

Judahite Regnal New Year as beginning in the autumn, rather than in the spring, at least in the later monarchic period (Josiah through Zedekiah).⁸⁹ The custom of counting the kings' years from the autumn was certainly not in keeping with the Babylonian or Assyrian systems. The implication is that the Judahite system was a preservation of a system that had been in use for some time before Assyria and Babylon had gained influence in the area. Without any evidence from the earlier periods either way, it is best to assume some consistency.

There is no direct evidence in the biblical text whether the northern kingdom of Israel counted its king's reigns from the autumn or spring. We should be inclined to think that the northern kingdom followed past custom from the United Monarchy (as indicated in the Gezer Calendar) and began the civil and regnal year in the autumn. However, there is evidence that suggests that Israel's regnal New Year did *not* coincide with that of Judah. It has to do with the reign of King Zechariah of Israel. He began to rule in the 38th year of Azariah of Judah and ruled for only six months (2 Kings 15:8). Yet his reign ended in the 39th year of Azariah (2 Kings 15:10). For this to be true, the regnal New Year in Judah would have passed during that six-month period, but not the regnal New Year in Israel. Otherwise, Zechariah would have been assigned a full regnal year by the chronographers.⁹⁰ A different regnal calendar year in Israel, therefore, would appear likely. To be sure, this argument assumes chronological agreement between the synchronisms and the reign total—in other words that the data would have to derive from the same source or from sources employing an identical method of calculation. As I will

⁸⁹ See Fried and Freedman, "Was the Jubilee Year Observed in Preexilic Judah?" 2259-61.

argue in Chapter Four, there is strong evidence to suggest that the synchronisms and the reign totals come from two different sources. However, other factors, discussed in Chapter Four, indicate that the northern Israelite reign totals reflect the same system of counting as the synchronisms (antedating). So this piece of evidence does seem to be a clear indicator of a regnal year in Israel that *did not begin in the autumn*, at least in the time of Zechariah. This leads us to believe that the civil and regnal year began in the spring, the most common time to begin a year in the ancient Near East next to the autumn.

A spring-based calendar might explain why northern Israel kept observing the beginning of its agricultural year in November. Judah harmonized the civil and agricultural year to coincide in September, as they were only two months apart to begin with. Israel's civil year, if it did indeed begin in the spring, would not have been harmonizable with its agricultural year. I will therefore tentatively assume the Israelite regnal year began in the spring. We do not know how long it would have been the custom there (although it is possible that Jeroboam I tampered with the calendar [1 Kings 12:33]), but with no other compelling evidence either way, it seems best to assume consistency and that there was always a difference between Israel and Judah's regnal calendars.

⁹⁰ Hayim Tadmor, "The Chronology of the First Temple Period: A Presentation and Evaluation of the Sources," in *Age of the Monarchies: Political History*, ed. Abraham Malamat and Israel Eph'al (Jerusalem: Massada Press, 1979): 50-51.

E. Lunar, Solar, and Lunisolar Calendars

Because it is much shorter than the tropical year, and because its beginning and end were more obvious and determinable with precision than that of the tropical year, the lunar month was often the benchmark of ancient calendars. In a strictly lunar calendar, time is simply measured month by month, and observation of the moon's phases settles the length of each month (29 or 30 days). A whole number of synodic months does not fit into a tropical year. The number that comes closest to $365 \frac{1}{4}$ days is 12, but 12 lunar months amount to only 354 days on the average (29.5×12), which is 11 days short of the tropical year. Thus, if a society were to employ a strictly lunar calendar, satisfied with 12 lunar months per "year," there would be little correlation between the months and the seasons of the year. A month that at one time came in the summer would, within the lifetime of one person, come also in the winter. This is the result of the 11-day discrepancy between a tropical and a lunar year, building up year after year.⁹¹ Any religious observances connected with seasonal phenomena would be thrown off. For this reason, most ancient calendars are not strictly lunar.

Attempts were almost always made to adjust the cycle of lunar months to coincide with the tropical year. The most common technique for harmonizing a lunar calendar with the solar year is intercalation, which is the insertion into the calendar of an extra month every so often, or, perhaps to phrase it more accurately, delaying the beginning of a new year by one month.⁹² So, for example, after three lunar years, the lunar calendar

⁹¹ The Assyrian calendar from the second millennium BCE would fall into this category (Cohen, *The Cultic Calendars of the Ancient Near East*, 17).

⁹² This was the custom in ancient Babylon before a more precise system was developed (Parker, *Babylonian Chronology, 626 B.C. - A.D. 75*, 1, Rochberg, "Astronomy and Calendars in Ancient Mesopotamia," 1931-32).

would be about 33 days short of the point in the tropical year at which it began, but another month could be added in that third year that would bring the calendar within 3 or 4 days of its original starting point. Calendars that employ intercalation of this sort are technically lunisolar calendars, although lunar calendar is still an appropriate term.

Solar calendars keep track only of the natural day and the tropical year. The month may be included in a solar calendar, but if so, is merely assigned an arbitrary number of days and has no relation to the actual phases of the moon. Nevertheless, because a whole number of days does not fit into a tropical year, a solar calendar has problems of its own. The incompatibility between days and years would not pose a serious problem in the short term (365 days is only $\frac{1}{4}$ of a day short of an actual tropical year), but over a long period of time the discrepancy would become more and more noticeable. In 730 years, the seasons would be completely reversed.⁹³

It is not difficult to determine which sort of calendar was used in ancient Israel. The agricultural year, based on the seasons, would necessarily be solar in nature. The civil and regnal years were to have begun always with a festival associated with the harvest. In a strictly lunar calendar, that would not be possible. The month Abib is named for a seasonal occurrence (the new grain, the ripening of the barley) and must have coincided with that season year after year. The Gezer Calendar assumes a year that consistently begins with the olive harvest, thus presupposing harmonization with the solar year. The civil calendar was either solar or lunisolar. Because of the evidence that the phases of the moon were observed (see above), we can confidently assume that a

⁹³ As in the Egyptian solar calendar (Clagett, *Ancient Egyptian Science*, 28-37).

lunisolar civil calendar was in place.⁹⁴ We have no direct evidence from the Bible,⁹⁵ but the Israelites probably would have used the common ancient Near Eastern system of intercalation: each year contained 12 months (cf. 1 Kings 4:7-19), and every three years or so, the new year would be delayed so that one more month could pass. What about the liturgical year? Can the same be said for the priestly calendar? Since the moon appears to have been observed (Gen 1:14) and seasonal festivals are precisely dated, there is little doubt that the priestly calendar too, although beginning at a different time of year, also was lunisolar in character.

⁹⁴ See J.B. Segal, "Intercalation and the Hebrew Calendar," *Vetus Testamentum* 7 (1957): 250-307, Vaux, *Ancient Israel: Its Life and Institutions*, 188-90, Hughes, *Secrets of the Times*, 161-65.

⁹⁵ Hughes (pp. 164-65) argues that the month difference between Judah's and Israel's harvest festival (1 Ki 12:32-33) was the result of an excessive intercalation of one month into Israel's calendar. However, this argument necessarily assumes that the act was an exception to custom. It thus cannot be used as evidence of custom.

II.

LONG-TIME RECKONING

A. The Counting of Time Units

A once popular theory was that, whereas we moderns tend to think of time as moving in a line, the ancient peoples thought of it as moving in a circle.⁹⁶ This rather tidy view is unsupported by the facts. It is evident that by the first millennium BCE most societies maintained *both* a cyclic and a linear understanding of time. Festivals and rituals observed in response to predictable and repeating natural phenomena are attuned to the cycles of time, while an interest in tying events of the past to those of more immediate recollection depends on a linear understanding of time, in which events succeed one another and are related through cause and effect. A system for measuring cyclic time is the calendar. Linear time is measured in the ancient world as well. How? The answer may seem obvious, but it bears articulating: by counting units of time in sequence. The very act of counting is a linear function, and the counting of non-recurring time units is

⁹⁶ An idea made famous in Mircea Eliade, *Cosmos and History: The Myth of the Eternal Return*, trans. Willard K. Trask (New York: Harper & Row, 1959). Eliade rightly calls attention to the various rites in ancient societies through which cosmic myths are relived year after year, but note his far-reaching conclusions: “What is of chief importance to us in these archaic systems is the abolition of concrete time, and hence their antihistorical intent. This refusal to preserve the memory of the past, even of the immediate past, seems to us to betoken a particular anthropology. We refer to archaic man’s refusal to accept himself as a historical being, his refusal to grant value to memory and hence to the unusual events (i.e., events without an archetypal model) that in fact constitute concrete duration. In the last analysis, what we discover in all these rites and all these attitudes is the will to devaluate time. Carried to their extreme, all the rites and all the behavior patterns that we have so far mentioned would be comprised in the following statement: ‘If we pay no attention to it, time does not exist; furthermore, where it becomes perceptible—because of man’s “sins,” i.e., when man departs from the archetype and falls into duration—time can be annulled.’ Basically, if viewed in its proper perspective, the life of archaic man (a life reduced to the repetition of archetypal acts, that is, to categories and not to events, to the unceasing rehearsal of the same primordial myths), although it takes place in time, does not bear the burden of time, does not record time’s irreversibility; in other words, completely ignores what is especially characteristic and decisive in a

practiced in all societies.⁹⁷ In relating one event to another in linear time, the space is measured by the number of units between one occurrence and another. This space can be measured in small or large units: days, weeks, months, seasons, years, etc. Thus in the Bible, for example, the ark was in the hands of the Philistines for 7 months (1 Sam 6:1) and in Kireath-jearim for 20 years (1 Sam 7:2); Nabal dies ten days after David decides to spare his life (1 Sam 25:38), and Menahem reigns ten years (2 Kings 15:17); the Israelites are in the wilderness for 40 years (Num 14:34), and the census taken by David takes 9 months and 20 days (2 Sam 24:8) (cf. also Num 11:19-20; Deut 1:2; 1 Sam 30:13). Note that these are not measurements of the length of repeated yearly observances, but of historical events—they happen just once in time, and then they are over.

The system of counting used in the sources is a bit different from our own, and it is important to have an understanding of this system whenever one is working in biblical chronology. Their use of ordinal numbers (1st, 2nd, 3rd, etc.) conforms to our modern understanding. The unit counted first was called the first, the second was called the second, and so on. We are always situated in a particular unit of time, whether that is a day, a month, a year, and, if we count forward or backward, we consider that unit to be the first in the sequence. Thus if I am counting days forward (using ordinal numbers),

consciousness of time. Like the mystic, like the religious man in general, the primitive lies in a continual present.”

⁹⁷ Note the difference between “non-recurring” and “non-cyclical.” Jean-Jacques Glassner asserts that “Mesopotamia did not know linear time,” because even when concerned in matters of historical chronology, the chronographers measured by units of time that were cyclical—years, months, and days (Jean-Jacques Glassner, *Mesopotamian Chronicles* [Atlanta: Society of Biblical Literature, 2004], 7). However, use of a cyclical unit does not make the measurement itself cyclical. Under such an assumption, there would be no such thing as linear time in *any* culture. A unit of measurement, such as a year, may be cyclical, but in linear measurement the unit is not repeated. That the Mesopotamians knew linear time is shown in B. Albrektson, *History and the Gods* (Lund: Gleerup, 1967), see esp. 94-95.

today is the first day, tomorrow the second, and so on. The Israelites counted the same way.

Cardinal numbers (1, 2, 3, etc.), however, are another matter entirely. The ancient Israelites employed an *inclusive* system of counting, reflected in all of the sources. An inclusive system assigns each and every unit a number; the first unit counted is called both “one” and “first” (cf. Gen 1:5, which could be translated either way). Occasionally we do this too: for example, when I say, “I was sick for three days,” I am probably counting inclusively (e.g., Tuesday, Wednesday, and Thursday). However, we moderns do not always assign the number one to the first unit in a sequence. When it comes to *measuring the distance between two points in time*, we count the units *exclusively*. In an exclusive count, the first unit is assigned no number.⁹⁸ For example in measuring the distance between today and a day in the future, we do not count today at all, but start with tomorrow. Thus tomorrow is *one* day from now, the day after that is *two* days from now, and so on. This is not how the Israelites counted. They count inclusively, even when measuring the distance between two points in time. *Today* they would call *one* day, tomorrow two days, the day after tomorrow three days, etc. Exactly one week from now would be eight days from now for them, while only seven days for us.

Table 2.1: The Count of Days

Exclusive count		1	2	3	4	5	6	7
	Sun	Mon	Tue	Wed	Thu	Fri	Sat	Sun
Inclusive count	1	2	3	4	5	6	7	8

⁹⁸ Or a zero. The ancient Israelites had no zero.

Evidence for this custom is all over the Bible. So, for example, in JE we have numerous occasions where the “third day” and “three days” are used to refer to the same period of time (Gen 30:36 and 31:22; 40:19-20; 42:17-18; Exod 19:15-16). In Dtr, we find the same (Josh 9:16-17; Judges 14:14-15; 1 Kings 12:5, 12). Also, “third year” and “three years” are synonymous (Deut 14:28 and 26:12; 1 Kings 22:1, 2; 2 Kings 18:9-10), and so are “seventh year” and “seven years” (Deut 15:1, 9; Judges 14:17). In P, “seventh day” and “seven days” are the same (Exod 12:15; Lev 13:4-6). So are “fiftieth day” and “fifty days” (Lev 23:16). To put this point another way, we might say that the Israelites see no difference between cardinal and ordinal numbers.

It is not true that inclusive counting is reserved only for small numbers (less than ten).⁹⁹ Although larger figures are scarcer in the text, we find that, when they do appear, inclusive counting is still the rule. Thus in Genesis 14, Chedorlaomer is served by the cities up until the twelfth year, and this is counted as “twelve years” (Gen 14:4). The prophet Jeremiah counts 23 years from the 13th year of Josiah to the 4th year of Jehoiakim (Jer 25:3). With Judah on an accession-year system (post-dating),¹⁰⁰ this can only be possible if the count is inclusive. By our count it is only 22 years. P’s Jubilee Year seems to be counted the same way as its Jubilee Day (thus the 50th year would be counted as 50 years). Although R is later than P, when P says that Noah was 600 years old at the Flood (Gen 7:6), R understands that to mean Noah’s 600th year (Gen 7:11). I have not, as yet, been able to find a single exception to this system of counting in any pre-exilic text.

⁹⁹ As implied in D.J.A. Clines, “The Evidence for an Autumnal New Year in Pre-exilic Israel Reconsidered,” *Journal of Biblical Literature* 93.1 (1974): 30.

¹⁰⁰ This will be demonstrated in Chapter Four.

Despite this form of measurement, when two or more large blocks of time are added together, although each of them may be reckoned inclusively, *their sum is exclusive*. In other words, the final unit of time in the first block does not overlap with the first unit of time in the second block. So, for example, in Dtr, where Caleb says 45 years have passed since Moses sent him to spy the land (Josh 14:10), because he is counting inclusively, he means 45 different years (we would measure this as 44 years). The first 40 years of his life (14:7), also counted inclusively, refers to 40 different years (we would measure this as 39). Yet, because there is no overlap, that is, the first year of the 45-year block is the year *after* the 40th year of his life, he can say the total is 85 inclusive years (84 in our own reckoning). Another case involves the 20 years that Solomon is said to have taken to build the Temple and the king's palace. The 20 years is the sum of two lesser periods: the 7 years it took to build the Temple (1 Kings 6:38), and the 13 years it took to build the palace (1 Kings 7:1). An inclusively-reckoned 7 years and an inclusively reckoned 13 years, added inclusively, should total 19 inclusive years, not 20. Thus, while each of the two periods might be reckoned inclusively, their sum is arrived at exclusively. Or, to be more precise, the 7th year in the first block of time is not the same as the 1st year in the second block. This makes sense, because we should not assume that Solomon's palace project began in the final year of the Temple building. The seventh year was occupied probably only with the Temple building, and the palace project commenced the following year. In other words, each year was dedicated to one project only.

Table 2.2: Time Covered by Solomon's Building Activities

Exclusive Year Count	Inclusive Year Count	Description of Project	Correct Inclusive Count of Each Period	Incorrect Inclusive Count of Each Period
0	1	Temple work	1	1
1	2	Temple work	2	2
2	3	Temple work	3	3
3	4	Temple work	4	4
4	5	Temple work	5	5
5	6	Temple work	6	6
6	7	Temple work	7	7/1 (temple & palace)
7	8	palace work	1	2
8	9	palace work	2	3
9	10	palace work	3	4
10	11	palace work	4	5
11	12	palace work	5	6
12	13	palace work	6	7
13	14	palace work	7	8
14	15	palace work	8	9
15	16	palace work	9	10
16	17	palace work	10	11
17	18	palace work	11	12
18	19	palace work	12	13
19	20	palace work	13	

The season of building is contained within a year. When it ends, it goes on hiatus until the following year. The last year of Temple work is not likely also to be the first year of palace work. What we have here is two periods reckoned inclusively, but not added together inclusively because the second period was not counted until it actually began. A year passed before the palace work commenced. This example illustrates the way large time units are counted in all situations. Each year carries one number, and only one number. My final example is from P. In the genealogy of Genesis 5, each entry consists of two periods of time, the years from a man's birth until the birth of his son, and the period from the birth of his son to his own death. These two periods, no doubt each counted inclusively, are added together exclusively.

This being the case, how might we understand compound designations, such as “one year and four months” (1 Sam 27:7)? “One year” would refer to the “first year.” The “four months,” then, which cannot overlap with the first year, must occur in the second year, but refer to a period of time between three and four months. In other words, the expression “one year and four months” is equivalent to “from the first year until the fourth month of the second year,” or perhaps, “all the first year, and up until the fourth month of the second year.” It would depend upon whether the writer was referring to calendar years or actual time. Since months were probably not numbered at the time of Dtr¹, we should probably assume this measurement is in actual time, and therefore the second interpretation is most likely.

To review the principles of counting, we note three important points:

1) All individual units of time (day, months, years, etc.) are added inclusively, so in translating into our own system of counting, we should consider all cardinal numbers to be ordinal, or alternately, to subtract one unit from the total to make an Israelite cardinal number into one of our cardinal numbers.

2) When adding together blocks of time, the Israelites did not overlap them. This is actually convenient for us, because we can add the numbers together normally, remembering simply to subtract one unit from the total ($[X + Y + Z] - 1$). Alternately, to be more precise, because the nature of the difference between their custom and ours has to do with when the count starts, we could subtract one unit from the first figure and add the rest normally ($[X - 1] + Y + Z$).

3) In keeping with this understanding, when encountering compound figures (e.g., 10 years and 6 months), we should realize that each part is inclusive, but there is no

overlap (in this case, 10 years and 6 months is equivalent to saying, in the 6th month after the 10th year, i.e., 9 years and 5 months).

Fortunately, the inclusive counting practice is of importance chiefly when we are in the realm of applied chronology, converting the dates of the sources into units of our own reckoning. When dealing with ancient Israelite chronography on its own, we need not get bogged down in conversions (and we won't).

B. The Exodus Era and the Egyptian Epoch

When it comes to periods of time that transcend a year, multiple years are never organized into convenient units of set length, such as decades, centuries, or millenniums. Blocks of time are created as it suits the calculator. Units are always counted individually (1, 2, 3, 4...) and measured from an important date (the birth of a famous person, the accession of a ruler, or a significant event), and end at an important date. The counting of years is a prominent feature of two of the ancient histories of Israel (P and Dtr). P employs a system of chronology based on the births of important people (genealogical in nature), which will be explored in the following chapter. Dtr employs a system or systems based on the terms of judges and kings, which will be explored in Chapter Four. Although rare, we do find in both P and Dtr events dated according to an *era* or *epoch* (a lengthy succession of years proceeding from a fixed point in time). Eras and epochs in any civilization were not always generated immediately when a great event occurred. More often they were created retrospectively as aids to the study of historical chronology. Such was the case with the era by which we count years today (AD/CE), and such appears to be the case in both P and Dtr.

Dtr dates the building of the Temple by the Israelites' exodus from Egypt: "And it was in the 480th year after the Israelites came out from the land of Egypt, in the fourth year, in the month of Ziv, that is, the 2nd month, after Solomon became king over Israel, that he built the house to Yahweh" (1 Kings 6:1).

The number 480 in Dtr is a multiple of 12 and 40, the number of months in a year (12) and the length of a Deuteronomic generation (40 years).¹⁰¹ This does not necessarily mean that the editor was saying that 12 generations passed between the Exodus and Solomon. The two numbers may have been chosen simply because they were symbolically meaningful. The parts of that 480 years are laid out in the DH rather explicitly.¹⁰²

45 years for the Exodus and Conquest (Josh 14:10)

70 years for the periods of oppression (Judg 3:8,14; 4:3; 6:1; 10:8)

200 years for the periods of rest (Judg 3:3,11; 5:31; 8:28)

76 years for the minor judges (Judg 10:1-4; 12:7-15)

3 years for the reign of Abimelech (Judg 9:22)

40 years for the Philistine oppression (Judg 13:1)¹⁰³

2 years for Saul (1 Sam 13:1)¹⁰⁴

¹⁰¹ On generations, see below.

¹⁰² A similar count is made in Richter, *Die Bearbeitung des 'Retterbuches' in der deuteronomistischen Epoche*, 132-41, but Richter ignores the figures in Judg 9:22, 10:8, and 13:1.

¹⁰³ This would include the terms of Samson and Samuel. The note at Judges 15:20 states a term of 20 years for Samson, which is placed "in the days of the Philistines" and thus assumes the period of Philistine oppression mentioned in 13:1 and must be included in the 40 years. A term for Samuel is conspicuously absent from the text, and this is most likely because it coincides with the final years of the Philistine oppression. The oppression clearly ends when Samuel is judge (1 Sam 7:13). The narrative could be interpreted to mean that his judgeship continues *after* the oppression is over, but the statement that "the hand of Yahweh was against the Philistines all the days of Samuel" suggests that the chronographer was counting the full term of Samuel in the oppression period.

40 years for David (1 Ki 2:11)

3 years for Solomon (1 Ki 6:1).¹⁰⁵

The symbolic significance of the 480 years makes it more likely that the periods within the period were arranged so that they added up to 480 years than that these smaller periods were simply added up and happened to equal 480 years. Keep in mind that the number 480 is ordinal, and so the period measured would, by our reckoning, equal 479 years. Even without having the total figure, we could count the parts inclusively (one year would be subtracted from the first unit of time), and the total would be 479 years.

Dtr refers to this era only once, and no other events in the work are dated by it. Neither does any work prior to Dtr date by this era. This makes it highly likely that the era is Dtr's own creation. Interestingly, the Redactor of the Primary History also dates the events of the wilderness wanderings from the Exodus in his waystation notices. Perhaps he does so simply because it is a logical date from which to count, but R's knowledge of Dtr makes it quite possible that he purposefully is dating according to the era created by Dtr. R, however, does not continue dating past the 41st year.

P begins its own epoch at the entry of the Israelites into Egypt: "And the dwelling of the Israelites, who had dwelt in Egypt, was 430 years. And it was at the end of the 430 years, and it was on this day exactly that all the armies of Yahweh went out from the land of Egypt" (Exod 12:40-41).

¹⁰⁴ Normally thought of as a scribal mistake, the short reign of Saul seems to fit just right into the 480-year period. Was the length of his reign shortened deliberately by the Deuteronomistic editor? Or is the figure original? See K.A.D. Smelik, *Saul, de voorstelling van Israëls eerste koning in de Masoretische tekst van het Oude Testament* (Dissertation, Amsterdam: P.E.T., 1977), 69-71.

¹⁰⁵ In an accession-year system of counting regnal years, Solomon's fourth year would have marked four actual years from his accession, but the Deuteronomistic editor seems to have not taken this into consideration and counted normally.

Because no events are dated according to this period of time (i.e., nothing is placed X years from the entry into Egypt), apart from the Exodus itself, it seems probable that the epoch is a creation of P. The number 430 has tended to defy attempts to give it symbolic meaning. It may simply be an educated guess but is almost certainly an inflation of the oppression period, which if historical, was probably much shorter. The priests may have inherited a tradition that the time of Joseph lay some 400 years into the past. However, the precise figure of 430 years may indeed be a priestly creation. It makes more sense when considered a part of P's larger chronological framework. P's genealogical chronology puts the birth of Jacob exactly 130 years before the entry into Egypt (Gen 47:7-9), and the Israelites' entry into the Promised Land exactly 40 years after the Exodus (Num 14:33-34). With the oppression 430 years long, the period from the birth of Jacob (Israel) to the entry into the Promised Land (Israel) would amount to exactly 600 years, a multiple of the numbers 12 and 50. The significance and sacredness of the number 12 in Israelite and Jewish literature is well known. The number 50 is also a special number in the priestly material (cf. Lev 23:15; Lev 25:10). The choice of 430 years may have been governed by the desire to make the total time, from the appearance of Israel as a man to the appearance of Israel as a country, equal 600 years.

C. Counting Generations

The Hebrew word דֹר (dôr) has the basic sense of "circle," with specific reference to a circular hut, and the meaning "assembly" is an extension of this basic

sense.¹⁰⁶ It is unclear from which sense of the word the Bible's most common meaning of *dôr* ("generation") derives (is it a "circle" of time, or an "assembly" of people?). A generation in ancient Israel was, as it is today, a group of individuals constituting a single step in the line of descent from an ancestor (cf. Exod 20:5).¹⁰⁷ When used as a measurement of time, it would naturally refer to the period between a point in one man's life and the same point in the life of his offspring, e.g., from a man's birth until the birth of his son(s). Since the age of a man at the birth of his children can vary, so the lengths of the generations may vary. Job was able to see his descendants to the fourth generation and himself lived 140 years (Job 42:16). If five generations (i.e., four generations plus Job himself)¹⁰⁸ encompass 140 years, the assumption is that a generation is equivalent to 28 years. Sometimes an author may use an average figure for a generation to make approximate calculations. The Deuteronomistic Historian, for example, assumes 40 years for a generation (Jos. 5:6-7) and uses this figure frequently (see Chapter Four).

One biblical example is sometimes provided to show that *dôr* may, when used as a length of measurement, also mean "life span."¹⁰⁹ Genesis 15:16 (JE) states that the Israelites will return from their oppression "in the fourth *dôr*" (דֹר רביעי). This statement appears to be supported by the Redactor's genealogy of Exodus 6:16-20, which recounts the immediate ancestors of Moses: Levi, Kohath, and Amram. Since Levi's

¹⁰⁶ Frank J. Neuberg, "An Unrecognized Meaning of Hebrew *dôr*," *Journal of Near Eastern Studies* 9.4 (1950): 215-17, Peter R. Ackroyd, "The Meaning of Hebrew *dôr* Considered," *Journal of Semitic Studies* 13.1 (1968): 3-10, D.N. Freedman and Jack R. Lundbom, "דֹר," in *Theological Dictionary of the Old Testament*, ed. G. Johannes Botterweck and Helmer Ringgren (Grand Rapids: Eerdmans, 1978) III: 169-81.

¹⁰⁷ The word may also be used in a general sense to refer simply to a population belonging to a single stratum of time (see Brin, *Concept of Time*, 58-61).

¹⁰⁸ On the counting of generations, see below.

¹⁰⁹ As in William Foxwell Albright, "Abram the Hebrew: A New Archaeological Interpretation," *Bulletin of the American Schools of Oriental Research* 1.163 (1961): 50-51.

generation is the one that entered Egypt, and Moses' generation is one that left, we find four generations covering the period of the Israelites' residence in Egypt. However, both Genesis 15:13 (JE) and Exodus 12:40 (P), state that the period of the Israelites' residence in Egypt amounted to at least 400 years. This seems far too long for four *generations*. This has led some to conclude that that the *dôrôt* mentioned in Genesis 15:16 are, in fact, life spans rather than generations.¹¹⁰ The life spans of Levi, Kohath and Amram add up to 407 years (137 + 133 + 137 = 407), approximately equal to the period of Egyptian residence. So it might seem that whoever calculated the length of the period did so by adding up the life spans of these men (or, alternately, by dividing the 400 odd years roughly by three and assigning each part to a generation).

Such a conclusion, however, assumes that the data in Exodus 6 must harmonize with Exodus 12:40 and Genesis 15:16, and that the chronographer deliberately ignored the fact that Levi, Kohath, and Amram are grandfather, father, and son by placing the three men's life spans back-to-back. To be sure, the fact that Genesis 15:13 and 15:16 are in the same source and in such close proximity suggests that the 400 years equals four *dôrôt*, and therefore a *dôr* would have to equal 100 years here. Since a generation would never be that long, but a life span would, it must be that the word *dôr* sometimes can refer to a life span. It should be remembered, however, that a figure of 100 years for a life span does not match J's fixed number for the full length of a person's life: 120 years (Gen 6:3). Propp makes a better case, noting that the number of generations is not cardinal, but ordinal. We are therefore to count the period as three full generations, plus part of

¹¹⁰ See, e.g., Freedman and Lundbom, "דור," 174.

another. He speculates that the 400 years equals three of J's life spans (120 x 3 = 360) plus 40 years (part of a fourth).¹¹¹

The case of Genesis 15:13-16 does present an interesting puzzle, and the data can be interpreted several ways:

- 1) The 400 years is being equated with a number of life spans.
- 2) The 400 years is being equated with a number of generations.
- 3) The 400 years and the דֹר רַבִּיעִי do not refer to the same period.
- 4) The two data contradict one another.

Militating against the first possibility is the fact that there are no other instances in the Bible where *dôr* refers to a person's full life span, and there is scanty evidence outside the Bible for the term used in that sense. An example sometimes cited as evidence is an inscription of Shamshi-Adad I of Assyria, wherein the king claims that seven *dārū* had elapsed between the *šulum Akkadîm* and his own time.¹¹² The word *dārū* is cognate with Hebrew *dôr* and is likewise normally understood as "generation." In this inscription it is understood by some to mean "life span," because seven generations before Shamshi-Adad would be too recent to place the event to which he refers. However, it would be a mistake to put too much stock in this reference. Even if Shamshi-Adad were measuring a period of time by life spans in this inscription, we would expect that he would be using a standard life span (a single fixed figure) as a yardstick by which to measure. He would not be referring to a sequence of seven life spans assigned to specific individuals in a linear genealogy, for the simple reason that, in reality, life spans are not sequential, but

¹¹¹ Propp, *Exodus 1-18*, 415.

overlap. Moreover, the often symbolic number seven is not likely to be literal. A better interpretation is that the king is referring to seven ideal *generations* (using the word *dārū* in its usual sense), the last and perfect of which is identified with his own.¹¹³ In other words, there is no correlation between the actual length of time covered and the number of *dārū* cited. It is simply a form of elevated speech. With no other evidence of *dôr* being used to mean “life span,” we may discount the first possible interpretation of the meaning of Genesis 15:13-16.

The third solution, which posits that the two data are referring to different periods, is also unlikely. The concluding points of both time periods are the same: the end of the oppression. That much is clear. The beginning point of the 400 years is the start of the oppression, and the beginning point of the four *dôrôt* must be understood to be either the start of the oppression or the present moment in the narrative (i.e., Abraham’s time). However, if the count of time begins immediately, then the problem is only exacerbated (the four *dôrôt* would have to cover a period longer than 400 years). It is best to take the passage at face value and consider both data as referring to the same period of time: the length of the oppression.

Militating against the fourth conclusion (that the data contradict one another) is the fact that the two pieces of information are textually very close to one another. This fact makes it likely that, even if they each are the creation of a different author or editor,

¹¹² *Annals of Archaeology and Anthropology* 19 (Liverpool, 1931), Pl. 81, i:18. The Akkadian word *šulum* can mean either the full realization of a state or its complete ruin. See Glassner, *Mesopotamian Chronicles*, 5-6.

¹¹³ Cf. “tenth generation” (Deut 23:2-3) and “thousandth generation” (Exod 20:6; Deut 5:10) in the Bible, which are not likely to be literal. Other extra-biblical examples are sometimes cited as evidence of measuring time by life spans, but they are few and come from times far removed from the biblical period.

the person responsible for the most recent datum was aware of the first and would not likely deliberately contradict it.

This leaves us with possibility #2, which, although it has its problems (a generation normally covers less than 50 years), is the least objectionable. While long generations are uncommon in the text, and unheard of in later times, they are still attested.¹¹⁴ The patriarchs in Genesis 5 all have sons at very old ages. After that, Noah has his three sons at 500, Shem has Arpachshad at 100, Terah has Abram at 70, and Abraham has Isaac at 100. The best solution to the difficulties associated with this passage is to assume that *dôr* is to be understood in its usual sense (always the first and best option unless facts force a different interpretation), but nevertheless to acknowledge a tension between verses 13 and 16 that was not intended by the original author. JE does not assume lengthy generations; P does. The datum of Genesis 15:16 (JE), which makes the period of Egyptian residence rather short, would have posed a problem to someone accustomed to a longer figure (R was well aware, not only of P's lengthy generations in Genesis, but of P's figure of 430 years for the oppression period in Exodus 12:40). How could the difficulty be fixed without eliminating the reference altogether? Fortunately, verse 16, while referring to generations, does not specify a length of time for each generation. This allowed the Redactor some freedom to play. Although equating four generations with 400 years is a stretch (and the Redactor no doubt knew this), the length of a generation in the Bible is never precise; it is always estimated. Something had to be

¹¹⁴ Cf. Shemaryahu Talmon, "»400 Jahre« oder »vier Generationen« (Gen 15,13-15): Geschichtliche Zeitangaben oder literarische Motive?" in *Die Hebräische Bibel und ihre zweifache Nachgeschichte* (Neukirchener Verlag, 1990): 13-25.

done to rectify the contradiction with Exodus 12:40, and the 400-year figure was still passable (rounded down from 430). So he added the gloss **ארבע מאות שנה**.

Generations seem to have been counted differently in ancient Israel than they are today. When looking forward in time, we normally begin counting with the generation of the parents. Thus, I would consider myself part of the first generation, and my children the second, and so on. Bible writers use a different system.¹¹⁵ The famous formula of Exodus 34:6-7, which was included in J, reckons *children* as the first generation, grandchildren as the second, etc. E counts similarly, reckoning Joseph's great-grandchildren as the third generation (Gen 50:23). Dtr places King Zechariah of Israel, the great-great-grandson of Jehu, in the fourth generation of Jehu's family (2 Ki 10:30; cf. 15:12). Ironically, when it comes to generations, we abandon our exclusive system of counting, and the Israelites abandon their inclusive system. Thus, when we consider Genesis 15:16, "the fourth generation" must be the great-great-grandchildren of the generation in which the Egyptian oppression begins. Although JE considers this the fourth generation, we would call it the fifth.

¹¹⁵ See Freedman and Lundbom, "דור," 174-75.

III.

GENEALOGICAL CHRONOLOGIES

A. Dating Events by the Life on an Individual

In the Hebrew Bible, only the priestly writer(s) (and the Deuteronomistic editor[s] to a limited degree) seem interested in constructing chronologies based on genealogical information. The Aaronid priests turn it into a science, and their chronology is based *primarily* on genealogies. This dating system forms a significant part of the narrative of the Torah as it now stands, especially the book of Genesis.

The priestly chronology dates events that occur prior to the Exodus by placing them within a specific year in the lifetime of an individual. Most of the events concern only the activities of the individual to whose life the events are dated.¹¹⁶ Not all of the events are genealogical in nature, but the births of sons are of particular interest to the author(s), and history is presented according to the passing of time in individuals' lives, rather than to regnal years of kings or judges or to dates of other notable events.

The priestly material occasionally refers to larger, broader events that are of relevance to a greater community, but nevertheless dates them according to the years of a specific person's life. In P, the universal Flood occurs in Noah's 600th year (Gen 7:6). In

¹¹⁶ "And Abram was a son of 75 years when he left Haran" (Gen 12:4); "And Abram was a son of 86 years when Hagar bore Ishmael to Abram" (Gen 16:15); "And Abram came to be a son of 99 years, and Yahweh appeared to Abram" (Gen 17:1); "And Abraham was a son of 100 years when his son Isaac was born to him" (Gen 21:5); "And Isaac came to be a son of 40 years when he took Rebekah the daughter of Bethuel, the Aramean from Paddan-aram, the sister of Laban the Aramean, for a wife" (Gen 25:20); "And Isaac was a son of 60 years when she gave birth to them" (Gen 25:26); "And Esau came to be a son of 40 years, and he took, as a wife, Judith the daughter of Beeri the Hittite, and Basemath the daughter of Elon the Hittite" (Gen 26:34); "Joseph was a son of 17 years, and he became a shepherd with his brothers among the flock" (Gen 37:2); "And Joseph was a son of 30 years when he stood before Pharaoh the king of Egypt" (Gen

R's chronology, the Flood begins in the 600th year of Noah's life (Gen 7:11) and ends in his 601st year (Gen 8:13-14). An additional datum concerns the time that the ark finally lands on the mountains (Gen 8:4-5).

Sometimes the characters themselves establish dates by naming their ages at a notable event. The date of the settlement of Jacob and his family in Egypt is presented in such a way:

And Joseph brought in his father Jacob and stood him before Pharaoh, and Jacob blessed Pharaoh. And Pharaoh said to Jacob, "How many are the days of the years of your life?" And Jacob said to Pharaoh, "The days of the years of my residences are 130 years. Few and bad have been the days of the years of my life, and they have not reached the days of the years of my forefathers' lives in the days of their residences" (Gen 47:7-9).

The Deuteronomistic Historian also uses this method. For example, when dating the succession of Joshua and the entry into Canaan according to the life of Moses, the information is presented in the first person:

And [Moses] said to them, "A son of 120 years I am today. I am not able to go out and come in anymore...." (Deut 31:2).

Similarly, the sending out of the spies, as well as the death of Joshua and the apportionment of the land of Canaan, is dated according to the life of Caleb and stated in the first person:

[Caleb said:] "A son of 40 years I was when Moses the servant of Yahweh sent me out of Qadesh-barnea to spy out the land.... And now, here Yahweh has kept me alive, just as he gave his word, these 45 years since Yahweh gave this word to Moses when Israel walked in the desert. And now here I am today a son of 85 years" (Josh 14:7,10).¹¹⁷

41:46); "And Moses was a son of 80 years and Aaron was a son of 83 years when they spoke to Pharaoh" (Exod 7:7).

¹¹⁷ It might be argued that this is a P account, because it seems to be referring to the P passages in Numbers, in which Caleb is sent out of Qadesh with the spies (Num 13:6; 14:6-9). However, the J version in the same

Though P, R, and to a lesser degree Dtr date many events by people's ages, a collection of these references does not constitute a chronology. All of them would be meaningless to the ancient (or modern) reader unless the lives of the various ancestors were associated with known dates. If I know that event X occurs in year Y of individual Z, I still do not know when event X took place unless I knew when individual Z was born. In other words, these dates are dependent on other information. For P, this information takes the form of a genealogy containing chronological data. The genealogy provides a framework for the history of the world, by which events in that history may be dated.

B. Genealogical Lists Containing Chronological Information

1. Description

P's chronological framework, which anchors its dates to an absolute chronology, is found throughout Genesis, but is concentrated in chapters 5 and 11, where we can see its basic form. In those chapters we find a list of ante- and post-diluvian ancestors recounted, along with the age of each ancestor at the birth of a significant son, the age of each ancestor at death, and the length of time between these two events. This scheme forms the basis of a lengthy chronology based on a family line running from Adam, through Seth, Noah, Shem, and then Abraham, Isaac and Jacob. In the latter sections of Genesis, the data tend to be dispersed throughout the narrative, but the nature of the data remains the same.

chapter of Numbers also features Caleb as one of the spies (Num 13:30-31), and Caleb's mention of the Anakim (giants) here in Joshua (14:12) is a clear reference to the J version (Num 13:22, 33). The

The basic form of the presentation of the chronology is as follows:

And PN1 came to be # years old, and he sired PN2; and PN1 lived, after his siring PN2, # years, and he sired sons and daughters. [And all the days of PN1 came to be # years, and he died.]

The final phrase (in brackets) is omitted in the list of Genesis 11.¹¹⁸ A striking feature of the list is the abnormally long life spans of the individuals listed. We should note, however, that the ages of the ancestors at their deaths have no bearing whatsoever on the chronology, which is set only by their ages at the births of their sons.

2. List-Making in the Ancient World

In order to understand the genealogical lists, it would be advantageous to consider the importance of lists in ancient scribal tradition. From our modern perspective, we might have trouble understanding an interest in the dry and repetitive recitation of seemingly pointless pieces of information, but the ability to memorize and recite lists, especially those that required counting and measuring, was, in the ancient world, an evidence of knowledge and wisdom, “a powerful medium for creating, organising, and disseminating knowledge of the past.”¹¹⁹ In ancient Mesopotamia, for example, lists were attempts to understand the universe by classifying and organizing its contents. Names

Deuteronomistic History draws from J frequently, but not from P. “Anakim” appears to be a Deuteronomic equivalent to J’s “Nephilim.”

¹¹⁸ The Samaritan Pentateuch, however, includes it.

¹¹⁹ Jeremy Graeme Taylor, *Framing the Past: The Roots of Greek Chronography* (Ph.D. Thesis, University of Michigan, 2000), 107.

were considered *substances*, inseparable emanations from the object named and an expression of divine will.¹²⁰

In Greece the practice of reciting lists to articulate segments of time and space is evident in Homer's Catalogue of Ships in Book II of the *Iliad* and in Hesiod's *Theogony* (8th century BCE). These lists are likely to predate the works in which they are now found. In other words, they stand out as literary forms different from the narratives in which they are embedded and which they serve to enhance. Homer's Catalogue of Ships is a survey of the Achaean and Trojan armed forces at the time of the Trojan War (*Iliad* 2:494-759, 816-877). When Homer begins to recite the ship catalogue, he makes a point of drawing attention to the difficulty of such a task, even invoking the Muses before he does so (2:484-493). He is able to divide up the armies into constituent parts, bringing clarity to the list through the use of names and numbers. That he can successfully recite the list demonstrates his skill as a cataloguer. Hesiod uses genealogies to explain the origins of the gods and as a way of introducing separate mythical episodes. He has memorized many lists of names, often giving the number of names in a list.¹²¹

From time to time, when reciting these lists, the poets highlight outstanding elements, perhaps, as in Homer, making note of the most able leader, or the most handsome soldier, or the best or most numerous troops, or the best horses, or, in Hesiod, the most beautiful, or the oldest, of the gods. These interjections or glosses of the poets evidence their knowledge of the memorized list and ability to size it up.¹²² Similarly, the

¹²⁰ Jean Bottéro, *Mesopotamia: Writing, Reasoning, and the Gods* (Chicago: University of Chicago Press, 1992), 29-31, 97-102.

¹²¹ See the discussion of both Homer and Hesiod in Taylor, *Framing the Past*, 107-39.

¹²² See *Ibid.*, 118-19.

priestly reciter of the biblical genealogy sometimes highlights notable figures, such as Enoch, who “walked with God” (Gen 5:22).

When lists were committed to writing, the scribes not only had opportunity to sort and classify material within each list, but also to compare and juxtapose lists with one another. When documents covering the same subject matter were collected, lists incorporating information from more than one document would be created.¹²³ This was true of lists of a chronological nature as well. The ancient chronographers viewed time as a constant, universal principle, and it was very important to their worldview that lists cohered with one another. They spent much time and energy dating significant events and individuals, and it was important for their chronologies to adhere to their historiographies. Often contradictions between two documents were found; since it was important for the documents to be consistent with one another, adjustments would need to be made, either to the original lists or to the diachronic list prepared from them, to calibrate the data. It is apparent that lists were not static in nature, but dynamic, constantly changing and being adapted.

3. Textual Variants of Genesis 5 and 11 and Their History

a) Genesis 5

In the various versions and translations of Genesis 5 and 11, there are discrepancies with respect to the figures. Before we can undertake a proper analysis of the chronology, it is necessary to understand the origin of the readings of the present

versions and ascertain each text tradition's evolution of development. We will first turn to Genesis 5.

Table 3.1: Variant Readings of the Numbers in Genesis 5

Citation	Ancestor	Proposed Archetype	SP	MT	LXX
Gen 5:3	Adam	130 + 800 = 930 (-1177 + 800 = -377)	130 + 800 = 930 (-1177 + 800 = -377)	130 + 800 = 930 (-1526 + 800 = -726)	230 + 700 = 930 (-2012 + 700 = -1312)
Gen 5:6	Seth	105 + 807 = 912 (-1072 + 807 = -265)	105 + 807 = 912 (-1072 + 807 = -265)	105 + 807 = 912 (-1421 + 807 = -614)	205 + 707 = 912 (-1807 + 707 = 1100)
Gen 5:9	Enosh	90 + 815 = 905 (-982 + 815 = -167)	90 + 815 = 905 (-982 + 815 = -167)	90 + 815 = 905 (-1331 + 815 = -516)	190 + 715 = 905 (-1617 + 715 = -902)
Gen 5:12	Kenan	70 + 840 = 910 (-912 + 840 = -72)	70 + 840 = 910 (-912 + 840 = -72)	70 + 840 = 910 (-1261 + 840 = -421)	170 + 740 = 910 (-1447 + 740 = -707)
Gen 5:15	Mahalalel	65 + 830 = 895 (-847 + 830 = -17)	65 + 830 = 895 (-847 + 830 = -17)	65 + 830 = 895 (-1196 + 830 = -366)	165 + 730 = 895 (-1282 + 730 = -552)
Gen 5:18	Jared	62 + 800 = 962 (-785 + 800 = 15)	62 + 785 = 847 (-785 + 785 = 0)	162 + 800 = 962 (-1034 + 800 = -234)	162 + 800 = 962 (-1120 + 800 = -320)
Gen 5:21	Enoch	65 + 300 = 365 (-720 + 300 = -420)	65 + 300 = 365 (-720 + 300 = -420)	65 + 300 = 365 (-969 + 300 = -669)	165 + 200 = 365 (-955 + 200 = -755)
Gen 5:25	Methuselah	67 + 902 = 969 (-653 + 902 = 249)	67 + 653 = 720 (-653 + 653 = 0)	187 + 782 = 969 (-782 + 782 = 0)	167 + 802 = 969 (-788 + 802 = 14)
Gen 5:28	Lamech	53 + 724 = 777 (-600 + 724 = 124)	53 + 600 = 653 (-600 + 600 = 0)	182 + 595 = 777 (-600 + 595 = -5)	188 + 565 = 753 (-600 + 565 = -35)
Gen 5:32	Noah	500 (-100)	500 (-100)	500 (-100)	500 (-100)
Gen 7:6; 9:28	Noah's age at Flood	600 + 350 = 950 (0 + 350 = 350)	600 + 350 = 950 (0 + 350 = 350)	600 + 350 = 950 (0 + 350 = 350)	600 + 350 = 950 (0 + 350 = 350)

*First # = age at begetting; second # = remaining years of life; third # = total life span
Numbers in parentheses represent years before the Flood*

Several recent textual studies of Genesis 5 have advanced our understanding of the formation of the variants.¹²⁴ A general observation of the different readings reveals that MT and SP agree on all entries except for those of Jared, Methuselah, and Lamech. LXX differs from MT and SP in that 100 years are added to the age of begetting and 100 years are subtracted from the remaining years of life in every entry, except for Jared, Methuselah, and Lamech. The scribes seem to have found the data regarding these three

¹²³ Ibid., 164-74.

¹²⁴ R.W. Klein, "Archaic Chronologies and the Textual History of the Old Testament," *Harvard Theological Review* 67 (1974): 255-63, Hughes, *Secrets of the Times*, 5-53, D.V. Etz, "The Numbers of Genesis V 3-31: A Suggested Conversion and its Implications," *Vetus Testamentum* 43 (1993): 171-89,

patriarchs problematic. The aforementioned studies have made a strong case that, *in the earliest manuscripts, the date for the Flood (the 600th year of Noah) was in conflict with the basic genealogical chronology found in Genesis 5*. Three of the antediluvian patriarchs (Jared, Methuselah, and Lamech) were given life spans in the genealogical chronology that placed their deaths after the Flood (i.e., after Noah's 600th year). According to the narrative, their survival of the Flood would be an impossibility (Gen 7:23). The chronological problems apparently went unnoticed by the original editor, but scribes from different manuscript traditions attempted to alleviate the difficulties in their own ways, and their activity explains the variations in the manuscripts.

In the Samaritan tradition, the life spans of the three problem ancestors were shortened, so that they would not extend beyond the Flood. The artificiality of their ages is apparent, when one notices that all three now die in the exact year of the Flood. The scribes took off only as many years as was absolutely necessary.

In the MT tradition, an early scribe or scribes made the decision to remove the lives of Jared, Methuselah, and Lamech further from the Flood by adding years to the ages of each of them at the birth of his son, and subtracting the same number from the years remaining in the life of the father, thereby retaining the original reading of the father's age at death. To Jared's age at the birth of Enoch 100 years were added, and this was sufficient to correct the problem. In the case of Methuselah, 100 years was not quite enough, so an even 120 years were added to his age at the birth of Lamech. This put Methuselah's death in the year of the Flood. There is disagreement among Klein, Hughes,

Etz, and Hendel regarding what MT did with Lamech. We should expect that a similar adjustment would have been made, i.e., an addition to Lamech's age at the birth of Noah. However, we will need to take a closer look at all the versions before confirming this conclusion.

In general, the case that the previously cited studies make to explain the reason for the revisions in SP and MT is very strong. The reasons for the adjustments in LXX, however, need to be examined again. According to the theory advanced by Hendel, the motivations for the changes made in the LXX tradition were the same as in the others: three men survived the Flood. So a similar strategy was employed as in MT (adding 100 years to the age of each father at the birth of his son, and subtracting 100 years from the years remaining in his life, thereby retaining the original reading of the father's age at death).¹²⁵ However, instead of merely correcting the years for Jared, Methuselah, and Lamech, as MT did, LXX apparently decided to make the same adjustment to *all* the fathers in the list. By pushing the ancestors backward in time, it was assumed that none of the three problematic ancestors would then have survived the Flood. Unfortunately, perhaps because of an oversight, Methuselah still survived the Flood. Indeed, in LXX Methuselah still lives 14 years beyond the Flood date.

Considering, however, that LXX's changes to the figures for every one of the fathers were insufficient to alleviate the problem of the Flood date, I do not think it likely that they have anything to do with the Flood date, or with Jared, Methuselah, and Lamech. Let us consider: is it not strange that LXX's systematic revisions, which consisted of adding 100 years to the ages of *all* the fathers at the births of their sons,

while retaining their total ages, did not ensure that all three of the problematic characters (Jared, Methuselah, and Lamech) died before the Flood? If the date of their deaths was such a concern, how could Methuselah remain uncorrected? Why go through all that trouble only to fail to achieve the intended goal? SP *only* adjusted the life spans of the three problematic characters. MT *only* adjusted the ages of the three problematic characters at the births of their sons. If that is all that was necessary, there was no need for LXX to change the ages of *all* the ancestors. Nevertheless, it did. Clearly, the scribes in the LXX tradition had other reasons for making the revisions. What was the purpose? Hendel's language, namely that the increase in the figures "serves to delay the onset of the Flood," obscures the nature of the revisions. From the point of view of the editors, none of the adjustments in *any* of the manuscripts delays the onset of the Flood, because the Flood's date is fixed by the chronology that comes after it. It happened a fixed number of years before the present. (All chronographers measure time back from their present. After all, this is the whole purpose of chronology.) What the increase in LXX's figures actually does is push the ancestors further away from their own time, as well as push back the date of creation. In the archetypal text, the date of creation would have been 1,307 years before the Flood. As other chronological documents became available and were compared with this chronology, some might have seen that the date of creation was far too recent and needed to be pushed back. This was more likely the motivation of the 100-year increases in LXX.¹²⁶

¹²⁵ Hendel, *Genesis 1-11*, 64.

¹²⁶ Cf. Gerhard Larsson, "The Chronology of the Pentateuch: A Comparison of the MT and LXX," *Journal of Biblical Literature* 102.3 (1983): 401-09.

The Greek Septuagint was born in a period when Hellenistic Jews were becoming increasingly interested in biblical chronology. Just before the translation first appeared, Berossus' *History of Babylonia* (c. 290 BCE) and Manetho's *History of Egypt* (mid-third century BCE) were published. Both of these works greatly influenced Jewish understanding of historical chronology, and attempts were made to harmonize the findings of these works with biblical chronology.¹²⁷ LXX's antediluvian chronology is probably reflective of such efforts, and it is possible that the alterations adopted by the Septuagint were a product of the system of the Jewish chronographer Demetrius, who is the first to make a defense of LXX's chronology. We might find an explanation for the variants by considering some of the following observations about Berossus and Manetho: Berossus begins his history of Babylonia 432,000 years before the Flood (he was influenced by the Sumerian King List), which is irreconcilable with biblical chronology.¹²⁸ The Jews and early Christians, however, did not lack ingenuity. The medieval chronographer George Syncellus (9th cent. CE), who names two Egyptian monks from c. 400 CE as his sources, tells us in his *Chronological Excerpts* that it was common among Jews and Christians to interpret Berossus' years as days in this section of his history.¹²⁹ The equation of years with days and vice versa was sometimes done for chronological purposes in the Hellenistic period (cf. the book of Daniel). Since 432,000 days is equal to 1,183 ½ solar years, the beginning of Babylonian history was understood to have commenced about 1,184 years before the Flood. It is quite possible that such an

¹²⁷ See the illuminating discussion by Ben Zion Wacholder, "Biblical Chronology in the Hellenistic World Chronicles," *Harvard Theological Review* 61 (1968): 451-81.

¹²⁸ Alden A. Mosshammer, ed., *Georgii Syncelli: Ecloga Chronographica* (Leipzig: BSB B.G. Teubner Verlagsgesellschaft, 1984), § 53.

¹²⁹ *Ibid.*, §§ 30-33.

interpretation, or a similar one, was held by the Hellenistic Jews who translated the Septuagint. In the original chronology of Genesis 5 (column 1 in the table above), Berossus' date for the beginning of Mesopotamian history would have fallen in the time of Adam before the birth of his son Seth. A synchronism would be impossible. The biblical chronology could be harmonized with Berossus only by extending the length of the period from Adam to Noah, and this is precisely what LXX does.¹³⁰ As for Manetho, he does not mention a Flood, but there is some evidence to suggest that some Jews and Christians considered the first eight dynasties that ruled from Memphis as antediluvian. John Malalas (6th cent. CE) in his *Chronicle* preserves a tradition that makes Sesostris of Dynasty XII the first Egyptian king of the line of Ham (Manetho calls him the greatest conqueror next to Osiris).¹³¹ This suggests that the Flood was understood by some to have occurred not long before Sesostris. Three dynasties of Herakleopolitan kings immediately precede Sesostris, and the first of these, Akhthoes, is considered the cruelest of all the Egyptian tyrants. Manetho says he was killed by a crocodile. It would have been natural for Jews and Christians to view this as a punishment from God, and the reign of Akhtheos sits right at a major transition point in Egyptian history—the end of the reigns of the original kings of Memphis and the beginning of a new set of kings.¹³² This would have been an ideal place for Jewish chronographers to have placed the Flood. Most significantly, such a view explains quite well the changes we find in LXX. Apart from the mythological reigns of the gods, Manetho's Dynasties I-VIII cover approximately

¹³⁰ For evidence of second- and first-century BCE Jewish chronographers trying to harmonize the Bible with Berossus, see Wacholder, "Biblical Chronology," 465.

¹³¹ Ioannis Malalae, *Chronographia; ex recensione Ludovici Dindorfii* (Bonnae: impensis E. Weberi, 1831), 21.

1,600 years.¹³³ In the biblical chronology, 1,600 years before the Flood was well prior to the creation of humankind. LXX, by extending the period in the chronology of Genesis 5, makes the two chronologies appear compatible. While we may never be able to know precisely how the LXX translators interpreted Berossus and Manetho, nor even know what version of the manuscripts they possessed, it is probable that they knew of these works and were interested in making the biblical chronology harmonize with them as best as possible. The translation was being prepared for a Hellenistic audience, and the Bible's history needed to be palatable to that audience. We should look at the LXX chronology in this context.¹³⁴

However, there are other tamperings in LXX, unrelated to a simple lengthening of time to push back the date of creation. Special attention needs to be given to the entry for Lamech in order to get closer to an explanation for the anomalous readings. Hendel, in agreement with Klein, argues that none of the three manuscript traditions retains the archetypal reading of the age of Lamech at the birth of Noah, and that the readings of MT and SP are the result of scribal errors.¹³⁵ Although mechanical errors are always possible, it is somewhat suspicious that nowhere else in the list of Genesis 5 do MT and SP have such errors, but they both happen to make mistakes in the same entry for the same person, one of the problematic ancestors, probably the most problematic of them all. Moreover, the scribal errors are said to be the result of the influence of readings several lines away and on the other side of the closest figure (two verses previously in MT and three verses

¹³² Gerald P. Verbrugge and John M. Wickersham, *Berossus and Manetho, Introduced and Translated* (Ann Arbor: University of Michigan Press, 1996), 137.

¹³³ Mosshammer, ed., *Georgii Syncelli: Ecloga Chronographica*, §§ 99-145.

¹³⁴ Directly below, in the discussion of Gen 11, we shall encounter further evidence of SP and LXX lengthening the chronology.

later in SP). Most detrimental to their theory is the fact that the Samaritan Pentateuch clearly has no error in its reading, because, if it did and the original reading for the age of Lamech at Noah's birth was 88 (as Klein and Hendel suggest), then Lamech's death presently would be set 35 years after the Flood. But in fact, as was mentioned above, the date for the Flood and for Lamech's death in SP coincide exactly. If a scribal error were made, there would be no such correspondence between the man's death and the Flood date. The perfect alignment demonstrates that the readings in SP are precisely as the scribes intended them to be.

I would argue, instead, that the archetype for Lamech's age at the birth of his son is in the Samaritan Pentateuch (53), in agreement with Hughes, and that the figures in all three traditions are by design. We must keep in mind that nowhere else in SP is the figure for the age of the father at the birth of his son adjusted. In all cases it is the age at death that is altered. In MT and LXX, on the other hand, the usual recourse is to adjust the age of the father at the birth of his son. It is therefore more likely that their figures for Lamech's age at the birth of Noah are adjusted than that SP's are.

In regard to the age of Lamech at his death, SP's reading, in light of the above considerations, is unlikely to be original. SP is more inclined to adjust the death age. We had best look to MT and LXX. However, MT and LXX differ in their readings, so which one are we to prefer? Klein argues that MT's reading is an artificial revision aimed at mimicking the seventy-sevenfold vengeance of the other Lamech from Cain's family line (4:24). Hughes similarly suggests that, since the figure is "obviously symbolic," it cannot be original. Hendel posits a scribal error influenced by a "reminiscence" of 4:24. It is

¹³⁵ Hendel, *Genesis 1-11*, 66-67.

unclear to me why a symbolic number necessarily must be ruled out as the archetype. Are we to assume that the archetypal readings are actual ages, and that no symbolism is to be expected in any of them? We need only to point to the age for Enoch at his death (365), often remarked to be based on the number of days in a solar year, to demonstrate that some of the archetypal numbers employed here may be symbolic. Even if the number 777 is based on the J genealogy of Genesis 4, this does not necessarily mean that it is not the archetype of the P text or of the redacted Torah, both of which are aware of J.

There is stronger evidence that LXX's figure for the age of Lamech at his death (753) is adjusted. One is immediately struck by its similarity to SP's figures (53 and 653). If, as has been established, SP's reading of 53 is the archetype for the age of Lamech at the birth of Noah, then we should expect that LXX would have adjusted this figure to 153, in keeping with its usual practice ($153 + 600 = 753$). If so, then it is interesting that its reading for the age of Lamech at his death (753) would put Lamech's death exactly in the year of the Flood. This suggests that the number 753 is a revision (and reduction), just as SP's figure of 653 is a revision (and reduction). I think, therefore, that we should prefer MT's higher reading of 777 for the archetype of Lamech's death age.

At this point it is possible to reconstruct an editorial history of the Lamech entry in the genealogy. The original reading was 53 for the age of Lamech at the birth of Noah, and 777 for the age of Lamech at his death ($53 + 724 = 777$). However, according to such a reading, Lamech would have died after the Flood. To correct this problem, SP followed its usual practice and reduced Lamech's death age to 653, putting his death date in the year of the Flood.

In MT, the adjustment was to add 129 years to the age of the father at the birth of the son, and to subtract 129 from the remaining years of his life. Technically, only 124 years needed to be added to the figure to make Lamech 177 when Noah was born, but the scribes apparently decided to add 5 more years, so as to put a decent gap between Lamech's death and the Flood. Why did they do this? It may have to do with God's statement to Noah that Noah, his wife, his sons, and his sons' wives are the only righteous people alive (Gen 7:1; cf. also 6:5-8). Lamech's prophecy in Genesis 5:29 clearly places him on the side of the righteous, so if he had lived up until the Flood, we would expect that he too would have been singled out as one deserving of special mention. To solve this problem, MT chose to end his life 5 years ahead of the Flood, thus preserving the image of Lamech as an upright man.

In LXX, Lamech's entry reflects three stages of revision:

1) In order to push back the date of creation, 100 years were added to all of the fathers' ages at the birth of their sons, and Lamech was no exception. This change may have been made during the preparation of the original translation into Greek, as Demetrius (3rd century BCE) assumes this long chronology (though not exactly) and lived during the time the translation was made.

2) However, after adding 100 years to the age of each father at the birth of his son, both Methuselah and Lamech still survived the Flood, Methuselah by 14 years and Lamech by 24 years. A later scribe noticed that Lamech lived beyond the Flood (he did not notice Methuselah), so he decided to reduce the figure of 777 to 753, putting Lamech's death in the year of the Flood.

3) That problem was solved, and the reading sat like this ($153 + 600 = 753$) for a time, but a further adjustment was then made. The figure of 153 was increased by 35 to 188 (and the figure of 600 was reduced by 35 in order to retain the life span), which had the effect of placing Lamech's death a full generation (35 years) before the Flood. The intention may have been the same as for MT: to avoid any implication that Lamech was among the wicked generation mentioned in Genesis 6:5-8 and 7:1. The scribe in the LXX tradition felt the gap between Lamech's death and the Flood should be larger than what the scribe who made the similar decision in the MT tradition felt.

b) Genesis 11

In the second major section of the genealogy (Gen 11:10-32), we find similar variations in the three manuscript traditions.

Table 3.2: Variant Readings of the Numbers in Genesis 11

Citation	Ancestor	Proposed Archetype	SP	MT	LXX
Gen 11:10	<i>adjustment to Flood date</i>	+2 (-1112)	+2 (-1762)	+2 (-1112)	+2 (-1677)
Gen 11:10	Shem	100 + 500 [= 600] (-1110 + 500 = -610)	100 + 500 = 600 (-1760 + 500 = -1260)	100 + 500 [= 600] (-1110 + 500 = -610)	100 + 500 [= 600] (-1675 + 500 = -1175)
Gen 11:12	Arpachshad	35 + 403 [= 438] (-1010 + 403 = -607)	135 + 303 = 438 (-1660 + 303 = -1357)	35 + 403 [= 438] (-1010 + 403 = -607)	135 + 430 [= 565] (-1575 + 430 = -1145)
Gen 11:13	Kenan				130 + 330 [= 460] (-1440 + 330 = -1110)
Gen 11:14	Shelah	30 + 403 [= 433] (-975 + 403 = -572)	130 + 303 = 433 (-1525 + 303 = -1222)	30 + 403 [= 433] (-975 + 403 = -572)	130 + 330 [= 460] (-1310 + 330 = -980)
Gen 11:16	Eber	34 + 370 [= 404] (-945 + 430 = -515)	134 + 270 = 404 (-1395 + 270 = -1125)	34 + 430 [= 464] (-945 + 430 = -515)	134 + 370 [= 504] (-1180 + 370 = -810)
Gen 11:18	Peleg	30 + 209 [= 239] (-911 + 209 = -702)	130 + 109 = 239 (-1261 + 109 = -1152)	30 + 209 [= 239] (-911 + 209 = -702)	130 + 209 [= 339] (-1046 + 209 = -837)
Gen 11:20	Reu	32 + 207 [= 239] (-881 + 207 = -674)	132 + 107 = 239 (-1131 + 107 = -1024)	32 + 207 [= 239] (-881 + 207 = -674)	132 + 207 [= 339] (-916 + 207 = -709)
Gen 11:22	Serug	30 + 200 [= 230] (-849 + 200 = -649)	130 + 100 = 230 (-999 + 100 = -899)	30 + 200 [= 230] (-849 + 200 = -649)	130 + 200 [= 330] (-784 + 200 = -584)
Gen 11:24	Nahor	29 + 119 [= 148] (-819 + 119 = -700)	79 + 69 = 148 (-869 + 69 = -800)	29 + 119 [= 148] (-819 + 119 = -700)	79 + 129 [= 208] (-654 + 129 = -525)
Gen 11:26, 32	Terah	70 [+ 135] = 205 (-790 + 135 = -655)	70 [+ 75] = 145 (-790 + 75 = -715)	70 [+ 135] = 205 (-790 + 135 = -655)	70 [+ 135] = 205 (-575 + 135 = -440)

First # = age at begetting; second # = remaining years of life; third # = total life span

Numbers in brackets are implied, but not written

Numbers in parentheses represent years before the Exodus¹³⁶

We see some of the same patterns in this portion of the list as we saw in Genesis

5. In this case, however, MT, rather than SP, has the shortest chronology, and SP follows the pattern that LXX displayed in Genesis 5. Apart from the last two entries, the ages for the fathers at the births of their sons in SP are 100 years greater than in MT, and 100 years fewer for the remaining years in the father's life. Thus the life spans in SP and MT are the same (except for Eber, whom we will consider below). LXX is also 100 years greater than MT in the ages of the fathers at the birth of their sons, but the remaining years in the father's life are exactly the same as in MT, and this results in total life span

¹³⁶ From the birth of Abraham to the birth of Isaac we count 100 years, to the birth of Jacob 60 years, to Jacob's entry into Egypt 130 years, to the Exodus 430 years. The LXX counts differently: from the birth of Abraham to his entry into Canaan 75 years (Gen 12:4-5), to the Exodus 430 years (Exod 12:40). (Note that the period from Abraham's arrival in Canaan to Jacob's arrival in Egypt, in all three manuscript traditions, is 215 years, exactly half of 430 years. LXX, therefore, effectively cuts the oppression period in half.)

that are 100 years greater than they are in MT and SP (except for Arpachshad and Shelah, whom we will discuss below).

Another interesting feature is that SP is the only text that actually records the life spans. The life spans in the other two are present only by implication (the reader must do the math). It would seem SP added the life span totals to make the pattern conform to the one in Genesis 5. The reason for the absence of the life span totals in the archetype of Genesis 11 will be discussed in section C.3. below.

From what we have considered in Genesis 5, we may reconstruct the basic textual history of these variants with some confidence.

- 1) The short chronology of MT is likely to be original.
- 2) SP has added 100 years to the ages of the fathers at the births of their sons, and subtracted the same number of years from the remaining time in the father's life, so as to retain the original life spans.
- 3) LXX has also added 100 years to the ages of the fathers at the births of their sons, but apparently was not concerned about altering the total life spans of the fathers (after all, the life spans are not provided in LXX as they are in SP), so the remaining years in the father's life went untouched, and the lifespans were increased by 100 years as a result.

In regard to this list, Hendel argues, in agreement with Klein, that the adjustments in SP and LXX were made to prevent so great an overlap of generations.¹³⁷ Apparently, the early scribes would have seen a problem with the fact that many of the ancestors were alive in Abraham's lifetime. I think more is being made out of this situation than need be.

There is nothing in the narrative to militate against such an overlap. In the case of Genesis 5, it is understandable that adjustments would need to be made for some of the fathers to die before the Flood. According to the narrative, their survival would be *impossible*. On the other hand, no impossibilities or anachronisms are created by an overlap of generations in Genesis 11. Would alterations really be called for? The nature of the revisions in Genesis 11 also weaken the argument. We find that LXX has, as it did in Genesis 5, added 100 years to the ages of the fathers at the births of their sons, but this time no effort is made to preserve the original life spans of these fathers. This tells us that the motivation for the changes must have nothing to do with making sure the ancestors die by a certain time, because the changes merely increase the ages of the men at their deaths. SP repeats what it did in Genesis 5 (reducing a life span) only in 11:32, and this suggests that only in this single instance is the change motivated by a desire to ensure the death of one of the fathers before a certain year. MT makes no adjustments to the chronology whatsoever, so at least in this tradition, the overlap of generations was not of sufficient concern to the scribes for them to make changes.

We must presume that LXX's revisions in Genesis 11 (including the addition of another ancestor, a second Kenan beside the one in 5:12) serve the same purpose they do in Genesis 5: to move the generations further back in time. Indeed the addition of a full generation between Arpachshad and Shelah can serve no other function. LXX's chronology pushes the Flood date back a further 565 years (cf. Gen 5 in LXX above). SP probably has similar motivations. Its Flood date has been pushed back 650 years. As in the case of Genesis 5, it seems likely that knowledge of other chronologies outside of the

¹³⁷ Hendel, *Genesis 1-11*, 62-63.

Bible, which placed the Flood further back in time, prompted these revisions. Josephus' famous passage from *Against Apion* (I:14), which equates the Israelite oppression in Egypt with the rule of the Hyksos, is based on Manetho's *History of Egypt*. Josephus' version of Manetho, which scholars today generally consider highly defective, assigns 511 years to the Hyksos rule (apparently Dynasties XVI and XVII). Africanus' version of Manetho assigns 669 years to these two dynasties, while Eusebius' version only gives Dynasty XVII to the shepherd-kings and assigns it 103 years. It is difficult to say which version (if any of these) the translators of LXX had before them. However, it is clear that they were uncomfortable with the 430 years given for the oppression period, and their attempt to cut it in half by a slick alteration of Exodus 12:40 ("And the dwelling of the Israelites that they dwelt in the land of Egypt *and in the land of Canaan*: 430 years") is a way of overcoming the chronological problem that they saw. Manetho assigns a lengthy period for Egyptian dynasties IX through XV (2,403 years according to Africanus and 1,316 according to Eusebius).¹³⁸ The original chronology of Genesis 11 (counting 1,014 years from the Flood to the Exodus) would not have been harmonizable with Manetho (whether according to Africanus or Eusebius). However, SP's and LXX's figures are compatible with Eusebius readings. If the scribes of SP and the translators of LXX had a version of Manetho like Eusebius', the adjustments to the biblical text may be the result of attempts to harmonize the two chronologies.

There are a few other anomalous readings to account for. With the knowledge that LXX added 100 years to the ages of the fathers at the births of their sons, we should expect that LXX's readings for Arpachshad and Shelah would be 135 + 403 and 130 +

¹³⁸ Verbrugge and Wickersham, *Berossus and Manetho*, 131-39.

403 respectively. Instead we get $135 + 430$ and $130 + 330$. In both cases, we have a change for the remaining years in the father's life. Klein is probably correct in attributing this discrepancy to scribal error. In the first case, a scribe would have confused שלש for שלשים. In the second, there would be the same mistake, plus a more serious error of writing שלש again instead of אברע.

MT also contains an error of the same sort in the entry for Eber. We should expect a reading of $34 + 270$ (the latter number preserved correctly in SP), but we get $34 + 430$ instead. This error is more difficult to account for, but Hendel is probably right to attribute it to an accidental copying of Shelah's remaining years of life, plus another misreading of שלש for שלשים.

The final anomalous reading to account for is SP's total age for Terah (145 instead of 205). The life of this patriarch is shortened by 60 years. We should expect a similar rationale as that for SP's shortened life spans in Genesis 5: a desire to make sure the person dies by a certain time (in this case, Terah). In Genesis 11:32 Terah dies, and the implication is that he does so before Abram's departure from Haran in 12:4-5. If Terah lived until 205, he would have survived Abram's departure by 60 years. SP solves this apparent contradiction by subtracting 60 years from Terah's life span, thus ensuring that Terah dies before Abram leaves (but as late as possible and thus in the exact year of Abram's departure). SP's method for alleviating the difficulty is the same as its method in Genesis 5. MT also was concerned about this problem, but solved it a different way: by removing the word בחרן ("in Haran") from the phrase "And the days of Terah *in Haran* were 205 years" in Genesis 11:32 (cf. LXX).

This analysis best explains the variant readings in MT, SP, and LXX. We therefore should be confident that a source text common to all three manuscript traditions contained the following figures:

Gen 5:3	Adam	$130 + 800 = 930$
Gen 5:6	Seth	$105 + 807 = 912$
Gen 5:9	Enosh	$90 + 815 = 905$
Gen 5:12	Kenan	$70 + 840 = 910$
Gen 5:15	Mahalalel	$65 + 830 = 895$
Gen 5:18	Jared	$62 + 800 = 962$
Gen 5:21	Enoch	$65 + 300 = 365$
Gen 5:25	Methuselah	$67 + 902 = 969$
Gen 5:28	Lamech	$53 + 724 = 777$
Gen 5:32	Noah	500
Gen 7:6; 9:28	Noah's age at Flood	$600 + 350 = 950$
Gen 11:10	Shem	$100 + 500 [= 600]$
Gen 11:10	adjustment	+2
Gen 11:12	Arpachshad	$35 + 403 [= 438]$
Gen 11:14	Shelah	$30 + 403 [= 433]$
Gen 11:16	Eber	$34 + 370 [= 404]$
Gen 11:18	Peleg	$30 + 209 [= 239]$
Gen 11:20	Reu	$32 + 207 [= 239]$
Gen 11:22	Serug	$30 + 200 [= 230]$
Gen 11:24	Nahor	$29 + 119 [= 148]$
Gen 11:26, 32	Terah	$70 [+ 135] = 205$

This, or something close to it, was the genealogical chronology of the redacted Primary History (pre-3rd century BCE).

C. Sources of the Priestly Genealogical Chronology

1. Preliminary Considerations

We may now work back from this archetypal chronology in order to determine its provenance. It is generally held that whoever included the material now in Genesis 5 and 11, either the author of P or the Redactor, gathered his chronological information from a written source and incorporated the data into the narrative, perhaps even reproducing the

source word-for-word. Many view the statement in Genesis 5:1 **זֶה סֵפֶר תּוֹלְדֹת אָדָם** (“This is the scroll of the generations of Adam”) as a citation of the source, or perhaps its own heading.¹³⁹ Considering that a similar statement occurs in LXX in Genesis 2:4 (“This is the scroll of the generations of the heavens and the earth”) and that the phrase “these are the generations” is used frequently throughout Genesis, it is best to assume a consistent use of **זֶה** and **אֵלֶּה הֵם** and see them as referring to the text that follows, rather than as pointers to a source. Our observation that the variations in the manuscripts of Genesis 5 and 11 were caused by the conflation of two partially-conflicting chronologies (a chronology for the Flood and a genealogical chronology) has sufficiently discredited the assumption that the genealogy of Jacob had already been harmonized into one unified system, chronology included, before the version we see before us was even composed. These chronologies were *not* harmonized before they came into our text. While it is probable that R composed the *toledot* headings, because they have knowledge of and organize all of the main Pentateuchal sources,¹⁴⁰ the genealogy of Genesis 5 and 11, for reasons I will show below, is most likely from P. If so, the heading cannot be a source citation, because R would not likely have known P’s source(s).

My reason for attributing the genealogy to P comes from the following considerations:

First, the date of the Flood appears twice. A precise date occurs in Genesis 7:11: “In the 600th year of Noah’s life, in the 2nd month, on the 17th day of the month, on this day, all the springs of the great deep were burst, and the gates of the skies were opened.”

¹³⁹ See, for example, Friedman, *The Bible with Sources Revealed*, 40.

This datum we have already established as redactorial (see Chapter One, Section C.2.). A more general date occurs in Genesis 7:6: “And Noah was a son of 600 years, and the flood came—waters on the earth.” Although this statement could also be from the hand of the composer of 7:11, it seems rather unnecessary for him to have provided *both* a general date and a more specific one. More likely is that the text has undergone expansion. The logical direction of growth would be from less specific to more specific information, so it is probable that the original datum is in Genesis 7:6, and that it was composed (or inserted) by the author of P. The Redactor was unsatisfied with the general time reference, and so added the specific year, month, and day to pinpoint the precise timing of the event. However, always respectful of his sources, and not willing to cut them, he left Genesis 7:6 in. The same can be said about the wilderness trek. P states that the Israelites were in the wilderness for 40 years (Num 14:34). However, R’s wilderness chronology adds precision to the general chronology of P, dating events down to the actual month and day in a given year.

Second, at the conclusion of the Noah pericope, we find this statement:

And Noah lived, after the flood, 350 years. And all the days of Noah were 950 years, and he died (Gen 9:28-29).

Now according to R, who seems intent on making the flood endure a complete year, Noah was 600 years old when the flood began (Gen 7:11), and 601 when it ended (Gen 8:13). This harmonizes with P’s datum, which also makes Noah 600 when the flood occurs (Gen 7:6). However, the year-long duration of the Flood creates a conflict with the

¹⁴⁰ See Cross, *CMHE*, 301-05, David Miano, "The Twelve Sepharim of the Torah," *The Biblical Historian* 1.1 (2004): 10-19.

datum in Genesis 9:28-29, which allows Noah a life of only 350 years after the flood, making his total life span 950 years.¹⁴¹ In R's scheme, Noah's life would add up to 951 years. So R overshoots the total by a year. This was not a problem for P, who simply put the flood in a single year (when Noah was 600).¹⁴² Thus Genesis 9:28-29 is in harmony with Genesis 7:6, which belongs to P, and not with Genesis 7:11 and 8:13, which belong to R.

Third, the phrasing of Genesis 9:28-29 mimics the phrasing found repeated so often in the genealogical list of Genesis 5:

And PN1 lived, after his siring PN2, # years, and he sired sons and daughters.

And all the days of PN1 came to be # years, and he died.

The similarity between the statement of Genesis 9:28-29 and the statements at the end of each entry in the genealogy of Genesis 5 suggests common authorship, particularly because we should expect a concluding rubric for Noah in the genealogy, and the one in Genesis 9:28-29 is the only one that exists. In short, the author of P is responsible (either as author or editor) for Genesis 5:3-32, Genesis 9:28-29, and Genesis 11:10b-26, and R is not.

¹⁴¹ When counting, I am understanding the phrase "after the Flood" in the same sense as the phrase "after his fathering PN" in Genesis 5 and 11. It could be argued that the 350 years is to be counted from the end of the downpour, rather than the end of the period that the waters overwhelmed the earth, and this indeed may be the way R understands the chronology (one of his sources, J, certainly does [Gen 7:17]). However, P explicitly defines the Flood as the period that the waters were on the earth (Gen 7:6).

¹⁴² The fact that these numbers are inclusively counted makes no difference. Remember that when adding up two blocks of time, even though each block is counted inclusively, because the second block begins the year after the first block ends, an additional year is added to the equation (see Chapter Two, Section A). Thus 601 (inclusive) + 350 (inclusive) + 1 = 951 (inclusive). If we restate the equation in our own temporal terms, we come up with the following: According to R, who seems intent on making the flood endure a complete year, Noah was 599 years old when the flood began, and 600 when it ended. This harmonizes with P's datum, which also makes Noah 599 when the flood occurs. However, the year's duration created a conflict with the datum in Genesis 9:28-29, which allows Noah a life of only 350 years after the flood, making his total life span 949 years. R's total is 600 + 350 = 950 (one year past 949).

What is interesting is that, while the chronological calculations in Genesis 5 are based on the years that fathers beget sons, the chronological calculation of Genesis 9:28-29 is based on the year of an event, namely, the Flood. We would expect that Noah's death age would be calculated from his age at the birth of his sons Shem, Ham, and Japheth, but such is not the case; it is based on the Flood date. Why is this fact significant? Recall that the variants in the manuscripts have suggested to us that earlier in the tradition *the Flood date was in conflict with other data in the genealogical chronology*. We concluded that the Flood date (the 600th year of Noah) is not likely to have been taken from the same source as the genealogical data. Yet the Flood date and the genealogy are interwoven in the present text and are mathematically dependent on one another. If the Flood date (the 600th year of Noah) is crucial to the phrase: "And Noah lived, after the flood, 350 years," and is not from the same source as the genealogical chronology, then logically, the statements *of the same pattern* in Genesis 5 ("And PN1 lived, after his siring PN2, # years") *also* cannot derive from the source that provided the genealogical chronology. That being the case, while two of the three numbers given in each entry in the genealogy (that is, the age of a father at the birth of his son and the father's total life span) could have come from a written source or sources that the editor possessed, it is doubtful that the middle figure (the years between the birth of a son and the death of his father) did. The intervening years between the event and the death of a patriarch *must be calculations of the editor*. In other words, if that phrase (and PN lived after [event] # years) incorporates numbers from two sources, it itself cannot come from either of those sources. The inference is that the author/editor of P was working with two chronologies and attempting to fit them together. This would mean all

the data in P's genealogical chronology do not come from a single source, but probably from two.

In regard to the two written sources from which the priestly author/editor theoretically drew (which most likely go unnamed), although it seems clear that the editor did not reproduce them verbatim, I believe it is possible to identify which information derives from which, and to reconstruct most of their chronological data with relative confidence. As we shall see, the first would have contained a generational chronology providing the age of each father at the birth of his son, and the other, which contained a date for the Flood (the 600th year of Noah), was part of a different chronology that provided also the long life spans of the patriarchs.

2. Pedigrees

a. Ancient Linear Genealogies in General

Pedigrees are genealogies that list the male members of a family in a vertical father/son sequence. They may move forward or backward in time. Their linear nature distinguishes them from “branching” genealogies, which spread out horizontally as well as vertically (cf. Genesis 10 [branching] with Genesis 11 [linear]).¹⁴³

Ancient Mesopotamian pedigrees of a greater depth than three or four generations are most often found in king lists, which list dynasties of rulers, father to son, providing their years of reign. In this group are the Sumerian King List (c. 21st to 17th century BCE), the Royal Chronicle of Lagaš (c. 18th century BCE), the Babylonian King List (c.

¹⁴³ Alternate terms are “linear genealogy” and “segmented genealogy.” See Robert R. Wilson, *Genealogy and History in the Biblical World* (New Haven: Yale University Press, 1977), 9.

18th century BCE), and the Assyrian King List (copies range from the 11th to the 8th century BCE).¹⁴⁴ The last is the best example in that it explicitly and more consistently refers to the genealogical relationship of a king to his predecessor. The beginning of the Assyrian King List contains some etiological genealogies that combine Amorite oral and Sumero-Akkadian written traditions about the ancient ancestors. They are called kings, but this attribution is likely secondary.

Early Greek pedigrees that might be comparable to those found in the Bible include Hecataeus' *Genealogies* and *Circuit of the Earth* (late sixth/early fifth century BCE), both of which are no longer extant, but which are commented on by others. Herodotus recounts an incident where Hecataeus claimed he could recite his ancestry back to the gods (16 generations).¹⁴⁵ On a tombstone is inscribed the pedigree of a man named Heropythos, who counts back 14 generations. The tombstone is generally dated to the first quarter of the fifth century.¹⁴⁶ The pedigree of Miltiades the Elder, consisting of 14 names, appears in Marcellinus' *Life of Thucydides* (fifth century CE), who cites a certain Didymus as his source (probably Didymus Chalcenterus of the first century BCE).¹⁴⁷ Didymus is likely to have obtained the information from a work entitled *Genealogies*, no longer extant, by the famous genealogist Pherecydes of Athens (c. 5th century BCE).¹⁴⁸ We might also include two Spartan pedigrees of 21 generations,

¹⁴⁴ Texts and translations in Glassner, *Mesopotamian Chronicles*. Full discussion in Wilson, *Genealogy and History in the Biblical World*, 72-114.

¹⁴⁵ Histories 2:143.1-144.2.

¹⁴⁶ E. Schwyzer, ed., *Dialectorum Graecarum Exempla Epigraphica Potiora* (Hildesheim: Georg Olms, 1960), 690.

¹⁴⁷ Marcellinus, *Vit. Thuc.* 2-4.

¹⁴⁸ Taylor, *Framing the Past*, 25.

reproduced in Herodotus.¹⁴⁹ Technically these are king lists, but like the Assyrian King List from Mesopotamia, they are presented in pedigree form and explicitly mention the genealogical relationship of a king to his predecessor. It would appear that persons are included who never ruled, and Spartan kings who are not in the straight line of descent are omitted. The noble families of Greece are likely to have kept track of their genealogies.¹⁵⁰ Pedigrees clearly show an interest in connecting the historical period of the present with the age of gods and heroes, and all the major families would have seen the need to provide some evidence of their connection to the past.¹⁵¹ We see evidence of this desire on the part of the postexilic Jewish community in the first several chapters of Chronicles, in which we find examples of living persons tracing their ancestry into the semi-mythic past. The Torah's genealogies do not extend all the way to the time of the writers, but the lists may be preserved portions of longer genealogies.

b. The Life Spans of the Forefathers

When we gather all of the data in the Torah concerned only with the ages of persons at their deaths,¹⁵² we find the life spans of the patriarchs running from Adam to Joshua, and they generally diminish the further down the list we go.

¹⁴⁹ Histories 7:204 and 8:131.2.

¹⁵⁰ Alden A. Mosshammer, *The Chronicle of Eusebius and Greek Chronographic Tradition* (Lewisburg, Pa.: Bucknell University Press, 1979), 101.

¹⁵¹ For a discussion of early Greek pedigrees, see Taylor, *Framing the Past*, 20-30.

¹⁵² The data from Genesis 5 and 11 is from our presumed archetypal text.

Adam	930
Seth	912
Enosh	905
Kenan	910
Mahalalel	895
Jared	962
Enoch	365
Methuselah	969
Lamech	777
Noah	950
Shem	600
Arpachshad	438
Shelah	433
Eber	404
Peleg	239
Reu	239
Serug	230
Nahor	148
Terah	205
Abraham	175
Sarah	127
Isaac	180
Jacob	147
Joseph	110
Levi	137
Kohath	133
Amram	137
Aaron	123
Moses	120
Joshua	110

The first question to ask is whether all of these data derive from the same source.

We have established, already, the likelihood that the data in Genesis 5 were composed or copied into the text by P. On the other end of the list of life spans, we are less certain who included them. Let us look at the precise wording of the entries for each person:

“And all the days of Adam, which he lived, were 930 years. And he died.”

“And all the days of Seth were 912 years. And he died.”

“And all the days of Enosh were 905 years. And he died.”

“And all the days of Kenan were 910 years. And he died.”

“And all the days of Mahalalel were 895 years. And he died.”

“And all the days of Jared were 962 years. And he died.”

“And all the days of Enoch were 365 years.... And he was no more, because God took him.”

“And all the days of Methuselah were 969 years. And he died.”

“And all the days of Lamech were 777 years. And he died.”

“And all the days of Noah were 950 years. And he died.”

“And the days of Terah were 205 years. And Terah died in Haran.”

“And the life of Sarah was 127 years. And Sarah died in Kiriath-arba.”

“These are the days of the years of the life of Abraham, which he lived: 175 years. And he expired and died, old and satisfied, and he was gathered to his people.”

“And the days of Isaac were 180 years. And he expired and died, old and satisfied with days.”

“And the days of Jacob, the years of his life, came to be 147 years.... And he expired and was gathered to his people.”

“And Joseph lived 110 years.”

“And Joseph died a son of 110 years.”

“And the years of the life of Levi were 137 years.”

“And the years of the life of Kohath were 133 years.”

“And the years of the life of Amram were 137 years.”

“And Aaron was a son of 123 years when he died.”

“And Moses was a son of 120 years when he died.”

“And Joshua the servant of Yahweh died a son of 110 years.”

We know that the entry concerning Aaron is not from P, but from R, since it is set directly in a document added by R (Num 33). We know also that the entries for Levi, Kohath, and Amram are from R, since they also are set directly in a pericope added by R (Exod 6:14-27).¹⁵³ Since the entry for Moses is worded exactly the same as the one for Aaron is, and is unlike any other, it can also confidently be assigned to R. The entry on Joshua stands apart, because, first of all, Joshua is not a descendant of anyone on the list, and second, because the entry is found in the book of Joshua (outside the Pentateuch). Of the two authors, only R had anything to do with the book of Joshua, so we should also probably assign the entry to him. We could entertain the idea that the datum is from a Deuteronomistic source, but, if so, it would be the only datum of this type from that

¹⁵³ See Friedman, *The Bible with Sources Revealed*, 128-29.

source, an anomaly. So R is still the best suggestion. The entry on Joseph matches the one on Joshua, and is unlike any other, so it too is most likely from R.

We can already see an interesting phenomenon. All the entries so far ascribed to R are at the conclusion of the list, running from Joseph to the end. Moreover, none of the entries by R contain the word יָמָיו ("the days of"), which is a stock phrase of P's genealogy of Genesis 5, whereas all of the non-R entries do. The only exception is the entry for Sarah. Is it possible that this entry is from R as well? Without Sarah, P's ages would run a straight male line from Adam to Jacob without any digressions and would therefore form a full and tidy paternal pedigree. Significantly, in contrast to all of the P entries, R's contributions, including Sarah, have no anchor whatsoever to P's genealogical chronology. In other words, it is impossible to date the deaths of the first five persons, and the dating of the deaths of the final three is possible only because of their (coincidental?) connection to the exodus/conquest chronology.

My argument is that one of the lists used by the author of P was a pedigree of the patriarchs from Adam to Jacob, which listed the life durations of each man. As I will go on to demonstrate, it appears this list also gave Noah's age at the time of the Flood: 600. Suffice it to say for now that the great age of Noah at this event coincides with the extreme ages of the persons on this list.

One might wonder why a list containing the total ages of the patriarchs would ever have been composed. Certainly the list would serve no chronological purpose, since death ages are irrelevant to chronology (unless one wishes to date a death) and cannot be used to create a timeline. (In other words, the years of the list cannot be added up to measure an era, because a son did not begin to live in the year his father died.) We are

left with no other conclusion but that the record of life spans serves another, probably ideological, purpose. When Hesiod recounts the cycle of ages, he draws attention to the long life spans of those who lived in days past as an evidence of their superiority, and notes how the life spans diminish with each successive age.¹⁵⁴ Similarly, a list showing the great ages of the ancestors of Israel probably emphasize the strength and greatness of the world's forefathers and the degenerate state of humankind in later times. As in Hesiod, there is a correspondence between the life durations of the patriarchs and the time period in which they live. Thus, those who live prior to the Flood (with the exception of Enoch, who is said to have died young) live between 700 and 1000 years, those who live from the Flood to Abraham (with the exception of Nahor, who is said to have died young) live between 200 and 600 years of age, and those who live from Abraham to Moses live between 100 and 200 years of age—might we say, an age of gold, an age of silver, and an age of bronze? The ability to recount specific numbers gives evidence of the superior knowledge of the scribe.

c. A Generational Pedigree in Genesis 5 and 11

The second source P used for his genealogical pedigree would have been a list of generations, with a figure indicating the length of each generation. The word *dôr* is not found in P's pedigree, but is a fitting descriptor for the length of time measured in the pedigree.

Although both the life span pedigree and the generational pedigree provided by P run all the way to Jacob and end there, indications are that the two lists originally were of

¹⁵⁴ *Works and Days*, ll. 109-201.

different lengths, and that the author of P had to add to the shorter one to make them equal. For the most part, the figures for the ages of the fathers at the births of their sons in P's genealogy are within the parameters of biological possibility, with the notable exception of Noah, and perhaps also Adam, Seth, Shem, and Abraham. When we examine the ages that are given for the fathers when they sire their sons, one notices that there is a descending pattern in the ages, with two notable exceptions in the middle, and three at the end:

130 (Adam begot Seth)
 105 (Seth begot Enosh)
 90 (Enosh begot Kenan)
 70 (Kenan begot Mahalalel)
 65 (Mahalalel begot Jared)
 62 (Jared begot Enoch)
 65 (Enoch begot Methuselah)
 67 (Methuselah begot Lamech)
 53 (Lamech begot Noah)
500 (Noah begot Shem)
100 (Shem begot Arpachshad)
 35 (Arpachshad begot Shelah)
 30 (Shelah begot Eber)
 34 (Eber begot Peleg)
 30 (Peleg begot Reu)
 32 (Reu begot Serug)
 30 (Serug begot Nahor)
 29 (Nahor begot Terah)
70 (Terah begot Abraham)
100 (Abraham begot Isaac)
60 (Isaac begot Jacob)

The entries for Noah and Shem in the middle, and Terah, Abraham and Isaac at the end, containing large, round numbers, are rather conspicuous anomalies in the list. Why might that be? For the middle entries I would suggest that other chronological data in the text are forcing the numbers to be higher. In the cases of Noah and Shem, the important Flood chronology is affecting the data. We have very specific information

elsewhere that Noah was 600 years old at the time the flood came (Gen 7:6). We also have information that Shem was 600 years old when he died (Gen 11:10-11). As was argued, these data probably come from the life span pedigree. If Noah's age at the birth of Shem was only around 50, as the overall pattern in the above list suggests he would be, and Shem's age was about 45 when he gave birth to Arpachshad, then we have a problem. Shem would have been 550 years old when the flood occurred, and Arpachshad would have been 505. Actually, several more generations would have been alive at the Flood, including the whole family line up to Abraham, Isaac, Jacob and Joseph! None of these persons could have been born before the flood, not even Arpachshad, because the Flood story makes it clear that only Noah, his wife, his three sons, and his sons' wives were on the ark. There weren't any grandchildren until afterward. It thus seems that the editor/author of P had to make some adjustments. He could have increased Shem's age to 551 or so at the time of his siring Arpachshad, but it would have been tougher for a reader to swallow the idea that Shem was so old when he accompanied his father on the ark and when he fathered a son. By making Noah (a very special man) 500 years old at the birth of his sons, and Shem 100 at the birth of his son, the story is a bit more believable and the difficulty is alleviated. We therefore have reason to doubt that these readings were in P's source text.

For the entries at the end of the list, the anomalous numbers suggest that the original list did not stretch all the way to Isaac and had to be supplemented. In Terah's case, a motivation for the higher age does not seem to be chronological. We have information from the life span pedigree that he died when he was 205 (Gen 11:32). We also have information that Abraham was 175 years old when he died (Gen 25:7). If Terah

were only about 30 years old, as the pattern in the present list suggests he would be, then Terah would have lived just long enough to see the death of his son. However, this observation would not have been sufficient motivation for the priestly editor to alter Terah's age, as is evidenced by the fact that several of Abraham's ancestors live well into his lifetime, and some beyond. The overlap of generations simply was not an issue. To be sure, the text implies that Terah was already dead when Abraham left for Canaan (cf. 11:32a [Terah's death notice] and 12:4b-5 [Abraham's departure], both of which are P texts), and this may have been cause for concern, particularly because the text originally read that Terah lived 205 years *in Haran* (see above), but an increase in Terah's age at Abraham's birth from 30 to 70 would not have resolved that problem. Thus no motivation for an alteration in the case of Terah is apparent, and yet since the reading does not fit the pattern of the pedigree, we are still wise to consider it alien. A reasonable explanation is that the original pedigree concluded with the birth of Terah, and since there was no figure for Terah's age at the birth of his son, or Abraham's at the birth of his, or Isaac's at the birth of his, the priestly editor had to create one. Still, why did he make the numbers so high? There certainly is a case for making Abraham's high, as he is supposed to be an old man at the birth of Isaac (cf. Gen 17:17), and in Isaac's case his wife is said to have been barren for some time (Gen 25:20-21). Yet there is nothing in the narrative that would demand that Abraham be as old as 100 or Isaac as old as 60 when their children are born. The priestly editor most likely was trying to extend the period from the Flood to the Israelites' entry into Egypt. Increasing the ages of Terah, Abraham, and Isaac allowed him to add another 100 years or more to the chronology.¹⁵⁵

¹⁵⁵ Cf. the similar motivations of LXX in Genesis 5 and both LXX and SP in Genesis 11 (see Section B.3.

The normal length of a generation in P's source can be seen in the more recent entries, i.e., Arpachshad through Nahor, and would have fallen between 29 and 35 years. As we go back in time through the list, the generations grow longer.

Arpachshad to Nahor = generation range 29-35

Lamech to Shem = generation range x 1.5 (44-53)

Kenan to Methuselah = generation range x 2 (58-70)

Seth to Enosh = generation range x 3 (87-105)

Adam = generation range x 4 (116-140)

While there are five divisions between each section of the generational chronology, each with its own generational norm, the life spans are consistent between Adam and Noah (700-1000 years) and then also between Shem and Abraham (200-600 years). In other words, there is no consistency between the life span norm and the generational norm. We thus have further evidence that the two lists were originally unrelated.¹⁵⁶

Although it is unusual to find a pedigree with a chronology built in, it is not unusual for pedigrees to be used for chronological purposes. Greek genealogies, for example, although they do not contain chronological data, were sometimes fitted into chronologies. Ever since the study of Eduard Meyer, it has been argued that Greek chronology was often *based* on their pedigrees.¹⁵⁷ Assuming a certain length of time for one generation, the ancient historians would calculate how far back certain persons would have lived. However, it may be more accurate to say that chronologies were created

above).

¹⁵⁶ Another example of unresolved inconsistency is that Moses, Aaron, and Joshua are in the era of extended life spans, but the curse of 40 years in the wilderness (Num 14:32-34) implies a realistic life span.

independently and then were harmonized with the genealogies. Greek historians played with generation lengths and imposed them on preexisting genealogies in order to fit famous persons of the past properly into an accepted timeline. No single generational “norm” figure was in use across the board. In fact, even a single chronographer might use more than one figure.¹⁵⁸ P appears to be doing the same thing, and its generational norm is likewise inconsistent.¹⁵⁹

3. Conclusions

From what we have seen, the genealogical list that begins in Genesis 5 appears to be a conflation of at least two different catalogues. One was a pedigree listing the ages of the fathers at the births of their sons. The numbers tended to be low. The other was a pedigree with the total ages of the patriarchs. The numbers tended to be high, and the Flood date was late in the life of Noah (600 years). With their combination, accommodations had to be made: Noah’s and Shem’s birthdates had to be changed. Moreover, there apparently were no birthdates for Abraham, Isaac, and Jacob, so these

¹⁵⁷ Eduard Meyer, "Herodots Chronologie der griechischen Sagengeschichte," in *Forschungen zur alten Geschichte* (Halle: Niemeyer, 1892) I: 151-88. See also Donald Wilson Pranken, *Studies in Greek Genealogical Chronology* (Lancaster, PA: Lancaster Press, 1943).

¹⁵⁸ Thus, for example, Herodotus appears to construct chronologies based on several different generation lengths, including 23, 26, 33, 34, 39 and 40 years. See discussion in Mosshammer, *The Chronicle of Eusebius and Greek Chronographic Tradition*, 105-12. Cf. also John Forsdyke, *Greece Before Homer: Ancient Chronology and Mythology* (New York: W.W. Norton, 1964), 28-43, Samuel, *Greek and Roman Chronology*, 241-45.

¹⁵⁹ As in Greece, Israelite genealogies originally were not created for historical purposes. Only later were they adopted to suit the needs of chronographers. See Wilson, *Genealogy and History in the Biblical World*, 199-200. That the genealogy of Genesis 5 once existed without the chronology is evident in that it appears, without the chronology and in an alternate form, in Genesis 4. For a comparison of the two genealogies, see *ibid.*, 161.

were supplied in accordance with the P author's conception of the length of time spanning Terah's and Joseph's lives.

Table 3.3: Sources of the Ages in the Priestly Genealogy

Verse	Name	Catalogue 1	Catalogue 2	Editor
Gen 5:3	Adam	130 (begot Seth)	930 (died)	
Gen 5:6	Seth	105 (begot Enosh)	912 (died)	
Gen 5:9	Enosh	90 (begot Kenan)	905 (died)	
Gen 5:12	Kenan	70 (begot Mahalalel)	910 (died)	
Gen 5:15	Mahalalel	65 (begot Jared)	895 (died)	
Gen 5:18	Jared	62 (begot Enoch)	962 (died)	
Gen 5:21	Enoch	65 (begot Methuselah)	365 (died)	
Gen 5:25	Methuselah	67 (begot Lamech)	969 (died)	
Gen 5:28	Lamech	53 (begot Noah)	777 (died)	
Gen 5:32	Noah	[50] (begot Shem)		500 (begot 3 sons)
Gen 7:6	Noah		600 (Flood)	
Gen 9:29	Noah		950 (died)	
Gen 11:10-11	Shem	[45] (begot Arpachshad)	600 (died)	100 (begot Arpach.)
Gen 11:12-13	Arpachshad	35 (begot Shelah)	438 (died)	
Gen 11:14-15	Shelah	30 (begot Eber)	433 (died)	
Gen 11:16-17	Eber	34 (begot Peleg)	404 (died)	
Gen 11:18-19	Peleg	30 (begot Reu)	239 (died)	
Gen 11:20-21	Reu	32 (begot Serug)	239 (died)	
Gen 11:22-23	Serug	30 (begot Nahor)	230 (died)	
Gen 11:24-25	Nahor	29 (begot Terah)	148 (died)	
Gen 11:26, 32	Terah		205 (died)	70 (begot 3 sons)
Gen 16:16	Abraham			86 (begot Ishmael)
Gen 21:5	Abraham			100 (begot Isaac)
Gen 25:7	Abraham		175 (died)	
Gen 25:26	Isaac			60 (begot Jacob)
Gen 35:28	Isaac		180 (died)	
Gen 47:28	Jacob		147 (died)	

When the priestly author/editor composed the lists in Genesis 5 and 11, he took the age of the father at the birth of his son from Source 1, calculated the interval between that age and the age of the man's death, as recorded in Source 2, and included the figure for the interval in the list (a number that did not appear in either source). In Genesis 11, he appears not to even have bothered to include the total age of the individual from

Source 2; he merely gave the figure for the intervening years. The reason for this difference is unclear, but may be simply because, while desiring to preserve the lengthy life spans to emphasize the greatness of the ancestors, he was not entirely comfortable with the chronological implications (the overlap of generations) and did not wish to make them obvious.

IV.

HEGEMONIC CHRONOLOGIES¹⁶⁰

A. Chronological Sources of the Deuteronomistic History

1. Time as Seen by the Deuteronomistic Historians and their Audiences

The chronology used in the Deuteronomistic History is, for the most part, concerned with the exploits of the rulers of Israel and Judah and derived from administrative records or earlier historiographic works.¹⁶¹ These sources, from which many of the chronological data are derived, need to be distinguished, sorted and compared. Also of interest are the artificial periods of time that the author and later reviser of the DH created to fill in gaps left by the sources. Moreover, we would do well to consider the Historian's and his editor's personal manners of reckoning time, according to the custom of their own day, which they sometimes employ in the DH in addition to the data derived from their sources. What will become apparent is that the original version of the DH (Dtr¹) contained a limited amount of chronological information and that the second edition (Dtr²) added much more to the History and systematized its chronology.

The chronological orientation of the exilic reviser of the DH is the easiest to apprehend, a great deal more so than that of the original composer/compiler of the History. We find an underlying assumption of a year beginning in the spring. Indeed, Babylonian chronology pervades the closing chapter of the DH (2 Kings 25). The first

¹⁶⁰ I use the term "hegemonic chronologies" to refer to those chronologies based upon the periods of time that leaders of various kinds held sway over a community.

edition of the DH, no doubt written in pre-exilic times during the reign of Josiah, does not appear to reflect a spring-based calendar (see Chapter One). A theory could be entertained that Dtr² was produced among the Jewish community in Egypt (cf. 2 Ki 25:26), but then we should expect an Egyptian calendar to be reflected in the text. Because the calendrical system to which the audience seems to be accustomed is in keeping with that used in Babylon, it probably is best to see the second edition of the DH as a product of the Babylonian community of Jews or of Jews elsewhere under Babylonian dominion.

Because there is clearly a connection between the DH and many of the prose sections of the Book of Jeremiah,¹⁶² it would be wise to examine Jeremiah to see what light it can shed on the method of reckoning that might have been employed in calculations related to the rulers of Israel by both the Deuteronomistic Historian and the later editor of the DH.

2. Chronological Sources for the Book of Jeremiah

It is important to note that *all* of the chronological material in Jeremiah has to do with events from Jehoiakim's reign forward. There are no data from the reign of Josiah apart from the superscription, which mentions only the 13th year of that king (627 BCE), the year of Jeremiah's call. Thus, while there may be a connection between the authorship of the Book of Jeremiah and the Deuteronomistic History, there is no evidence

¹⁶¹ The historian cites a number of these sources (see below). Textual analysis has shown dependence on unnamed sources as well. See Mordechai Cogan, *1 Kings* (New York: Doubleday, 2001), 88-95

¹⁶² See Jack R. Lundbom, "Jeremiah, Book of," in *Anchor Bible Dictionary*, ed. D.N. Freedman (Garden City: Doubleday, 1992) III: 706-21, Richard Elliott Friedman, "The Deuteronomistic School," in *Fortunate*

in the book of Jeremiah of an interest in chronology by Jeremiah himself, or by whatever scribe he employed, at the time the DH was first published.

In the fourth year of King Jehoiakim (605 BCE), some years after the initial publication of the DH and many years before its exilic revision, the scribe Baruch ben Neriah was asked to write a scroll for Jeremiah, which appears to have included both earlier material from the reign of Josiah and new oracles pertaining to the current situation in Judah and the then reigning king Jehoiakim (Jer 36:1-32).¹⁶³ The scroll was destroyed, but a new one was composed shortly afterward (c. 604), and some have argued that the contents of this rewritten scroll corresponded roughly to the first 20 chapters of the present book.¹⁶⁴ Most of the material is poetry, although small sections of prose are scattered throughout. Little of the writing bears resemblance to the prose of the Deuteronomistic History. If Baruch wrote this section in 604, it involved little free composition. It appears to be simply a compilation of Jeremiah's early and current prophecies. Notable is that there are no chronological references anywhere in the poetry or the prose.

From 605 to the end of Jeremiah's career sometime in the exile, a great deal more material was added to the collection by Baruch, and perhaps others. There is a significant amount of prose in these later additions, an indication that Baruch was permitted to compose with greater freedom in relating the experiences of the prophet, and for the first

the Eyes that See: Essays in Honor of David Noel Freedman in Celebration of his Seventieth Birthday, ed. Astrid B. et al Beck (Grand Rapids: Eerdmans, 1995): 70-80.

¹⁶³ Jack R. Lundbom, *Jeremiah 1-20* (New York: Doubleday, 1999), 92-93 The date for the composition of this scroll is arrived at by counting 23 years (Jer. 25:1-3) from the 13th year of Josiah (Jer. 1:2), i.e., 627 BCE.

time we are able to glimpse his literary talent and style. The narrative sections are similar to the prose of the DH and reveal a greater interest in dates, although not as much as we might suppose. There are differences between the chronological notices in Jeremiah and the DH, some of which are governed by the subject matter, as in the case of the common phrase “the word of Yahweh came to Jeremiah,” which we naturally would not expect to find in the DH, but which is a common feature of the Jeremianic chronological notices. Another common feature of the Jeremianic notices is the phrase PN ראשית ממלכת (‘‘in the beginning of the reign of PN’’), which has sometimes been associated mistakenly with the Akkadian expression *reš šarruti*. However, unlike the term מלכתן (as in, e.g., 2 Ki 25:27), which is a closer semantic equivalent of *reš šarruti*, ראשית ממלכת is a non-technical term used to refer to a general time and does not mean ‘‘accession year.’’¹⁶⁵ The use of this general expression in the book of Jeremiah suggests that the phrase does not come from a chronological source text, but is rather a creation of the scribe himself, who may be writing from memory. The phrase most often occurs by itself (26:1; 27:1; 49:34). It does, in one case, appear along with more precise data (28:1).

Jeremiah 28:1 makes an excellent case study of the formation of the chronological references in the book. The superscription to the narrative reads as follows:

ויהי בשנה ההיא בראשית ממלכת צדקיה מלך יהודה בשנת הרבעית בחדש החמישי

And it happened in that year, in the beginning of the reign of Zedekiah the king of Judah, in the fourth year in the fifth month

¹⁶⁴ Jack R. Lundbom, *Jeremiah: A Study in Ancient Hebrew Rhetoric*, 2nd ed. (Winona Lake: Eisenbrauns, 1997), 42-44, Lundbom, *Jeremiah 1-20*, 93-95. This grouping of chapters is held together by an inclusio, Jeremiah’s comment in 20:18 referring back to his call and commission (1:5).

The expression **בשנה ההיא** (“in that year”) refers back to the events of the previous narrative (which is mistakenly attributed in MT’s reading of 27:1 to the reign of Jehoiakim, but is correctly stated as Zedekiah in a few manuscripts). Of interest is the double time reference that follows. Both “the beginning of the reign of Zedekiah” and “the fourth year in the fifth month” appear. It was hardly necessary for both references to be included by the original writer, and although the more general reference does not mean “accession year,” there still is a certain amount of tension between the two dates, so the text has most likely undergone expansion.¹⁶⁶ The logical direction of growth would be from less specific to more specific information, so it is probable that the original reading contained only mention of the beginning of Zedekiah’s reign. What this tells us is that a later editor was unsatisfied with the original composer’s general time reference, and so he added the specific year and month reference. Interestingly, the phrase “in the fourth year in the fifth month,” because it dates an event both to a year and a month, resembles only the chronological notices in the final chapter of the DH (2 Kings 25), an exilic addition. Revisions like these suggest that the earlier authors of the book of Jeremiah and the Deuteronomistic History had less interest in chronological specificity than those who revised the works. We will examine this phenomenon in the Deuteronomistic History in more detail below and see how it has a bearing on the chronology itself.

¹⁶⁶ See Mordechai Cogan, “Chronology, Hebrew Bible,” in *Anchor Bible Dictionary*, ed. D.N. Freedman (New York: Doubleday, 1992) I: 1002-11, esp. 1006.

3. Chronological Sources Relating to the Judges

The earliest hegemonic chronological data in the DH is found in the book of Judges. The introduction to the book (2:6-23) provides a framework for its stories, which contain the following elements:

- 1) The Israelites do what is bad in the sight of Yahweh.
- 2) Yahweh gives Israel into the power of an oppressor, whom they serve for a specific term of years.
- 3) The Israelites cry out to Yahweh.
- 4) Yahweh raises up a savior.
- 5) The savior delivers Israel.
- 6) The foe is subdued.
- 7) The land is quiet for a specified term of years.

An analysis of the chronological presentation in the Book of Judges suggests that this cycle began as a creation of the original composer/compiler of the Deuteronomistic History, but was schematized further by the reviser of the History, who wrote the introduction to the Judges narratives.¹⁶⁷ The elements of most interest to us are #2 and #7, each of which provides a chronological datum. The first covers a period of time during which Israel is understood not to have had a leader to govern it. The second apparently represents a period of time that passed between the victory of a judge (#6) and the beginning of the next oppression (#1).

¹⁶⁶ See Jack R. Lundbom, *Jeremiah 21-36* (New York: Doubleday, 2004), 329.

¹⁶⁷ For a discussion of the evidence that suggests that the composer of Judges 2:11-19 was not the same as the composer of the cycle of stories that follow, see Baruch Halpern, *The First Historians: The Hebrew Bible and History* (San Francisco: Harper & Row, 1988), 121-40.

Considering the periods of peace first (item #7), we may make some interesting observations. The term is always given as 40 years, except in one instance, where a term of 80 years is given (3:30). However, the higher figure in this latter instance may be intended to cover the judgeships of both Ehud and Shamgar (3:31), in which case we would have to conclude that the chronological notice of 3:30 presupposes the existence of 3:31. In other words, the 80-year period of peace assumes the existence of both Ehud and Shamgar, so the brief comment concerning Shamgar is unlikely to be a late addition.¹⁶⁸ One might wonder why the author did not simply put a 40-year period of peace after Ehud and then another after Shamgar (separately). The explanation most likely has to do with the fact that the Philistine oppression does not end until the time of Saul. It would therefore be impossible to claim a 40-year calm after the victory of Shamgar over the Philistines. The Philistines are understood to be a thorn in Israel's side for some time afterwards. At the same time, the editor wanted to account for the judgeship of Shamgar. The simplest way to maintain the pattern was to create a double period of peace after Ehud.

The figures given for the periods of oppression (item #2 on the list above) may or may not exhibit a pattern, but the scale tips slightly in favor of the former.

¹⁶⁸ It is often argued that the note about Shamgar is a late interpolation that ruins the narrative flow from 3:30 to 4:1 (see, e.g., Soggin, *Judges*, 57-59). Yet verse 30 is incomplete in MT and should have ended with the phrase "And Ehud judged them until he died," as is evidenced by LXX. (The loss is attributable to haplography due to homoeoarcton.) The note that "Ehud had died" in 4:1 only seems necessary if the text

(1) Judges 3:8	Mesopotamian oppression	8 years
(2) Judges 3:14	Moabite oppression	18 years
(3) Judges 4:3	Canaanite oppression	20 years
(4) Judges 6:1	Midianite oppression	7 years
(5) Judges 10:8	Ammonite oppression	18 years
(6) Judges 13:1	Philistine oppression	40 years

As has been noted by Hughes, there seems to be a form of schematic parallelism between the period of the first three oppressions and the period of the second three.¹⁶⁹ To make the parallel even closer, Hughes suggests that the text concerning the Mesopotamian oppression originally read 7 years. No extant manuscript contains such a reading, however. To support his view, Hughes points out that the figure of 300 years for the period from the settlement to the beginning of the Ammonite oppression given at Judges 11:26 would exactly match the total of the 45 years mentioned at Joshua 14:10 and the first four figures here, plus the 3 years of Abimelech (Judges 9:22), if it were reduced by one year. As tempting as it would be to assume an original reading of “7” in Judges 3:8, the evidence of Judges 11:26 is simply not enough to justify this position. Until a manuscript shows up with this reading, it is best to retain the figure 8. On the other hand, the figures given in this list do seem somewhat artificial. There is an ascending pattern in each group of three numbers, the first two numbers in the sequence are almost identical in each group, and the final number in the second group is exactly double the final number

had diverged from its context and required a resumptive repetition to bring the audience back to the main storyline. In parallel verses (3:12; 6:1; 10:6; 13:1), we see no such repetition.

¹⁶⁹ Hughes, *Secrets of the Times*, 73.

in the first group. This suggests that they did not come from a primary document or inscription and are the creation of an editor, just as the figures for the periods of rest are.

I wish to discuss another set of chronological figures in the Book of Judges, which may bear on our understanding of the other periods. These are the terms of office for six of the judges (Tola, Jair, Jephthah, Ibzan, Elon, and Abdon). The chronology associated with these judges has a very different character from the periods of rest and periods of oppression. However, there are no instances where the History gives a specific term length for a judge *and* a 40-year period of rest, and this suggests that one set of figures is dependent on the other. These judges' terms appear to derive from a source document that was incorporated into the History at the time of its initial composition.¹⁷⁰ The document is in the form of a list, which recounts a succession of judges in annalistic fashion, many of whom do not have significant narratives about them in Judges, and includes the durations of their hegemonies over Israel. Each entry contains a picturesque description of the judge's kinsmen, which appears to be there as a memory aid. The document is split in half, the first part appearing in 10:1-5 and the second part in 12:7-15. Similarity in language seems to indicate that fragments also appear in 8:30, 32. The entire extant text (with minor reconstructions) reads as follows:

[And after him Gideon son of Joash rose up to deliver Israel. And he judged Israel ? years.] And Gideon had seventy sons that issued from his member, for he had many wives. Then Gideon the son of Joash died at a good old age, and he was buried in the tomb of his father Joash at Ophrah of the Abiezrites.

And after [him],¹⁷¹ Tola the son of Puah the son of Dodo, a man of Issachar, rose up to deliver Israel, and he was a resident in Shamir in the

¹⁷⁰ Soggin, *Judges*, 195-200.

¹⁷¹ The text reads "after Abimelech," but Abimelech does not feature in the list, and in all other instances, the list uses the expression "After him."

hill country of Ephraim. And he judged Israel twenty-three years. Then he died, and he was buried in Shamir.

And after him, Jair the Gileadite rose up. And he judged Israel twenty-two years. And he had thirty sons who rode on thirty donkeys; and they had thirty towns,¹⁷² which are in the land of the Gilead. Then Jair died, and he was buried in Qamon.

[And after him, Jephthah the Gileadite rose up.]¹⁷³ And Jephthah judged Israel six years. Then Jephthah the Gileadite died, and he was buried in his town in Gilead.¹⁷⁴

And after him, Ibzan from Bethlehem judged Israel. And he had thirty sons; and thirty daughters he sent to the outside, and thirty daughters he brought in for his sons from the outside. And he judged Israel seven years. Then Ibzan died, and was buried in Bethlehem.

And after him, Elon the Zebulunite judged Israel. And he judged Israel ten years. Then Elon the Zebulunite died, and he was buried at Aijalon in the land of Zebulun.

And after him, Abdon the son of Hillel the Pirathonite judged Israel. And he had forty sons and thirty grandsons, who rode on seventy donkeys. And he judged Israel eight years. Then Abdon son of Hillel the Pirathonite died, and was buried in Pirathon in the land of Ephraim, in the hill country of the Amalekites.

One of the first observations we can make about this document is that the beginning is missing. In all probability, the document was incomplete when the Deuteronomistic Historian put it into the History. If the number of years for Gideon's term were known, he would have preferred to retain that figure rather than providing a general 40-year period to cover his time. We know this, because when he incorporated

¹⁷² Reading עריים, as in LXX, instead of MT עירי (see Robert G. Boling, "Some Conflate Readings in Joshua-Judges," *Vetus Testamentum* 16 [1966], 295-96). The following sentence, "Them they call the Villages of Jair to this day," is an addition by the Deuteronomistic Historian, as is evidenced by his typical expression "until this day" (see Jeffrey C. Geoghegan, *Until Whose Day? A Study of the Phrase "Until This Day" in the Deuteronomistic History*, History [Ph.D. Thesis, University of California, San Diego, 1999]).

¹⁷³ These words are missing in the biblical text, because they had to be removed in order for the narrative as it stands to make sense.

¹⁷⁴ MT reads, "in the towns of Gilead," which could only be true if Jephthah's body parts were buried in separate places. LXX's reading ("in his town in Gilead") is preferable.

the Jephthah traditions into the work, he retained the six-year figure from this source document, rather than sticking in his usual 40-year figure.

The judges' terms of office as given in this source document do not display any patterns that might suggest that the numbers are artificial. In this they differ greatly from the periods of rest and the periods of oppression. Whether we may trust them as historically reliable is another question, but since they are incomplete and there is no way to anchor any part of this short chronology to a known historical date, they are not likely to be useful for any historical chronological calculations.

Closer examination of the Book of Judges seems to indicate that the numbers associated with the periods of oppression were not created by the same editor/author as the one who devised the figures for the 40-year periods of peace. It is usually understood that the calm that sets over the land ("the land had no disturbance") refers to a time that extends from an Israelite victory over one oppressor until the beginning of the next oppression (and this is certainly what the creator of the oppression chronology has in mind). However, the original intention seems to have been to indicate that the 40-years is *a period between wars*. The Deuteronomistic Historian, in a similar description of a period of calm, explicitly says this: "the land had no disturbance *from war*" (Joshua 11:23). In other words, when the 40 years is over, a war should break out. The editor who created the periods of oppression, on the other hand, understands only a period of servitude to follow the 40 years, and not a war. Sometimes the oppressors make raids on Israel, but no real battles take place until a judge rises up. In the original edition of the History, the 40-year periods are more or less equivalent to the terms of the judges. This appears to be confirmed by Judges 4:1, which tells us that Ehud's death, which marked

the end of his judgeship, also marked the end of 40 years (see also 3:11 and 8:48). Use of the 40-year gaps was a convenient substitution for a term of office and a way for the Deuteronomistic Historian to move the stories forward in time one generation. An additional piece of evidence that suggests that the oppression chronology is secondary is in Judges 10:8, where the figure for the period of Ammonite oppression interrupts the flow of the sentence in which it is embedded:

And they shattered and oppressed the Israelites in that year—18 years—, all the Israelites that were on the side of the Jordan in the land of the Amorites that was in Gilead.

Moreover, the mention of an oppression of both Ammonites *and* Philistines in the previous verse (part of the original DH narrative) sets the stage for the exploits not only of Jephthah, who fought the Ammonites, but of Samson and Samuel, who fought the Philistines, making the notice of a 40-year Philistine oppression in Judges 13:1 superfluous. A final piece of evidence is that, without the oppression periods, the total time of the period from the entry into Canaan to the rise of Jephthah equals 290 years plus the length of the reign of Abimelech (unstated in the first edition), a total that coincides with the 300-year figure mentioned by Jephthah in Judges 11:26.¹⁷⁵

The purpose of the expanded chronology that included the periods of oppression (and the note about the 3-year kingship of Abimelech in Judges 9:22) is to create a chronological period for the time of the judges that equals 479 years, so that the

¹⁷⁵ 5 years for the Conquest (Josh 14:10), 40 years for the passing of one generation (Judg 2:10), 40 years each for Othniel, Ehud, Shamgar, Deborah, and Gideon (200 years total), 23 years for Tola (Judg 10:2), and 22 years for Jair (Judg 10:3). It would seem that the Historian estimated 10 years for Abimelech, although he never states so.

construction of the Temple could be placed in the 480th year after the Exodus.¹⁷⁶ Before the additions, the History accounted for only 424 (inclusive) years of this period,¹⁷⁷ and that it contained no figure for the reign of Abimelech or a figure covering the interval between the judgeship of Samson and the reign of Saul, and thus he saw a need to fill it out and beef it up.¹⁷⁸ The original editor was not as concerned about constructing such a definitive chronology. He had source documents with chronological information that he saw fit to include, but his inconsistent use of them and his use of round numbers to cover periods between events, and his apparent lack of interest in accounting for every time period, demonstrates that he was not motivated to specificity.

4. Chronological Sources Relating to the Kings

a. Preliminary Considerations

Many historians and biblical scholars have attempted to make sense of the chronological data found in the books of the Kings. Some have been more successful than others, but all who have tackled the problem have had significant difficulties in understanding the systems employed. The failure of scholars to comprehend the data is

¹⁷⁶ The figure is created by the multiplication of two significant numbers, 12 (the number of months in a year) and 40 (the number of years in a generation).

¹⁷⁷ 45 years for the wilderness wanderings and conquest (Josh 14:10), 40 years for the passing of one generation, 40 years each for Othniel, Ehud, Shamgar, Deborah, and Gideon (200 years total), 76 years from the fragmentary Judges list, 20 years for Samson (Judg 16:31), 40 years for David (1 Ki 2:11), and 3 years for Solomon (1 Ki 6:1). Although this total is 424 years, the reviser of the DH believed it accounted for only 384, because while the Josianic historian saw a gap between the death of Joshua and the judgeship of Othniel, the reviser apparently saw Othniel as an immediate successor to Joshua.

¹⁷⁸ The gap was filled simply by creating a Philistine oppression period of 40 years (Judges 13:1). The note at Judges 15:20, which states a term of 20 years for Samson (and is based on Judges 16:31), places that term “in the days of the Philistines” and thus assumes the period of Philistine oppression mentioned in 13:1 and must be included in the 40 years. The note that Samson was active during the days of the Philistines therefore was added by the reviser of the History. The Philistine oppression continues through the judgeship of Samuel. See Chapter Two, Section B.

surprising, considering that the chronological notices in the final edition of the Deuteronomistic History are presented so systematically. For each king, the length of reign is provided along with a synchronic note tying his accession to a specific year of a contemporary king. For the kings of Judah, their age at accession and their mother's name are also given. Nevertheless, the numbers do not (always) add up. The usual recourse is to invent an elaborate and complicated theory to make the numbers conform to one another and, if necessary to ensure the proper outcome, to make significant emendations to the text under the assumption the data have somehow been corrupted by miscopying.¹⁷⁹ It is the opinion of the present author that the usual approach is suspect. Instead of considering the chronological systems of each of the Deuteronomistic Historian's sources separately, scholars collect all of the chronological data from all of the sources and treat them homogeneously, hoping to find consistency among them. One must either assume that a system exists that will harmonize all data or abandon all hope of comprehending the data. The problem has only been exacerbated since the discovery of chronological material from kingdoms contemporary with Israel and Judah, in particular Assyria. These data are thrown into the pot as well, and the resulting discord further removes us from a decent understanding of the chronology. This faulty approach

¹⁷⁹ Almost every book that has been written on the subject assumes this posture. The most well-known is Thiele, *MNHC*. In his preface, he writes, "For more than two thousand years Hebrew chronology has been a serious problem for Old Testament scholars. Every effort to weave the chronological data of the kings of Israel and Judah into some sort of harmonious scheme seemed doomed to failure. The numbers for the one kingdom could not, it seemed, be made to agree with the numbers in the other.... The problem is one with which I wrestled long before vague outlines of a solution began to crystallize in my mind." In a more recent work, Christine Tetley states: "On the assumption that the compiler of 1-2 Kings wrote a synchronistic record using preexisting annals of Judah and Israel, one expects that the original regnal years and accession synchronisms were internally consistent and coherent. If, through centuries of transmission, an error occurred in a number, the alteration would affect the congruency of an otherwise consistent system" (M. Christine Tetley, *The Reconstructed Chronology of the Divided Kingdom* [Winona Lake: Eisenbrauns, 2005], 93).

to the material is no doubt motivated by a desire to determine the reality behind the numbers in as few steps as possible. However, we can never ascertain the reliability of the biblical data until we first understand each source as an independent unit. Only then can we make comparisons with extrabiblical data and make a judgment.

To be sure, several or all of the Deuteronomistic Historian's sources may contain accurate chronological data that derive ultimately from the king lists of each kingdom or from royal chronicles, and it is also possible that the synchronisms between the two kingdoms might come originally from a document very much like the Synchronistic Chronicle from Assyria.¹⁸⁰ Indeed, if the data comes from primary texts that contained historically reliable information, some might argue that there is no need to separate sources, since the data ultimately derive from the same source and should jibe. However, there is no such congruity, neither can a trace to a common source be made; and the author makes no mention of official king lists or a synchronistic chronicle. The works to which he refers at the close of the presentation of each reign and which no doubt provided him with his information are secondary sources, and we do not know their exact relation to the archival data. Moreover, we do not know whether the systems used for calculating regnal years are the same in all the documents. Therefore, unless we know how each system works and that no historical errors have crept into the data, either by accident or by design, we cannot assume a single system of measurement, and then, in an effort to make the numbers conform to reality, restore a presumed original by

¹⁸⁰ This Babylonian document provides a concise history of relations between Babylonia and Assyria from the reign of Puzur-Ashur III (1503-1479) to Adad-nirari III (811-783). It exists in fragmentary form in 7th century copies found at Nineveh and. Text and translation in Glassner, *Mesopotamian Chronicles*, 176-83

“correcting” the figures. I, therefore, have decided to organize the data according to source and analyze each system on its own terms.

The historian has provided us with the names of a number of his sources, and three are the most likely to have provided him with chronological data: *The Scroll of the Affairs of the Days for the Kings of Judah*, *The Scroll of the Affairs of the Days for the Kings of Israel*, and *The Scroll of the Affairs of Solomon*. He makes reference to these works in the formulas that close a narrative about a particular king. The first source is cited 15 times, the second 17 times, and the third once (1 Kings 11:41). It would seem that these scrolls had a reputation in the author’s intended audience and were held to be authoritative. Besides chronological information, it would appear they contained records of wars, public works and other royal projects, tribute payments, conspiracies against the crown, and cultic violations.

The manner in which the chronological data is presented aids us in identifying the source. For example, dated events containing a month reference are rare and occur in only two sections of the Deuteronomistic History: in the account of Solomon’s building projects (1 Kings 6, 8) and in the history’s denouement, which includes the accounts of the final siege of Jerusalem by King Nebuchadnezzar of Babylon, the brief governorship of Gedaliah, and the fate of Jehoiachin (2 Kings 25). Since the monthly data connected with Solomon’s building projects are restricted to a small section of the History, they probably derive from one of the historian’s less-used sources, perhaps *The Scroll of the Affairs of Solomon* (1 Kings 11:41), which is not referred to elsewhere in the DH. The data for Nebuchadnezzar’s siege of Jerusalem come from an unnamed source, but the month references extend from the siege of Jerusalem (588) to the 37th year of the exile of

Jehoiachin (560). All the events could easily have occurred in the lifetime of the reviser of the Deuteronomistic History and reflect a Babylonian system of reckoning, and may even come from a Babylonian source, or the dates could have been calculated and recorded by the reviser himself as the events occurred. Either way, the month references in 2 Kings 25 are from an exilic perspective, and it is unlikely that *The Scroll of the Affairs of the Days for the Kings of Judah* (hereafter referred to as the Judahite Royal Chronicle) provided any of this information. Dates containing a month reference are conspicuously absent in the history of the period from Rehoboam to Jehoiachin. In Jeremiah, dates containing a month occur for the reigns of two kings of Judah, Jehoiakim and Zedekiah, and of the governorship of Gedaliah, all of which are found in the second half of the book and for which no source is cited. As was discussed above, it is not certain that these dates were originally in a pre-exilic edition of the book of Jeremiah. Even if some of them were, all the dated events occurred in the lifetimes of Jeremiah and his scribe Baruch, so they may not have been taken from a written source at all. Rather, they simply would be dates that the author recorded personally.

b. King Lists

The framework for the presentation of the chronological data in the books of Kings is very distinctive and easily recognizable. One formula repeated throughout the history of the kingdoms is that of the Judahite accessions, which comes in two patterns:

1) בשנת # (שנה) ל PN (בן־PN) (מלך ישראל) מלך PN (בן־PN) (מלך יהודה) (על־יהודה)

בן־# שנה היה במלכו

ו# שנים מלך בירושלם

ושם אמו PN (בת־PN) (מ־GN)

*In the [#] (year) of PN (the son of PN), (the king of Israel), PN (the son of PN),
(the king of Judah), became king (over Judah).*

He was [#] years old at his accession,

and [#] years he reigned in Jerusalem,

and the name of his mother was PN (the daughter of PN) (from GN).

2)

שנה היה PN במלכו

בן

ו# שנים מלך בירושלם

ושם אמו PN (בת־PN) (מ־GN)

PN was [#] years old at his accession,

and [#] years he reigned in Jerusalem,

and the name of his mother was PN (the daughter of PN) (from GN).

Elements in parentheses may or may not appear, but often do. Pattern 1 appears in the formulas from Rehoboam to Hezekiah and is notable in that it opens with a long chronological datum tying the accession to the specific regnal year of an Israelite king. Pattern 2 appears in the formulas from Manasseh to Zedekiah and omits the synchronism with the kingdom of Israel (for the obvious reason that the Israelite monarchy no longer existed).

It could be argued that the synchronisms do not derive from an actual source, but are a creation of the Deuteronomistic Historian, who used the lengths of the reigns of the kings, which *were* derived from an actual source, to calculate the time for the accession of each king in relation to the reign of a king from the sister kingdom. Weighing against this proposition is the fact that there are several synchronisms that could not have been calculated this way (1 Kings 14:25; 2 Kings 12:7; 18:9-10, 13); these synchronisms are placed in the midst of king's reigns, rather than at the beginning, and therefore must have been either completely invented or derived from a source used by the Historian. It therefore seems best to assume that the Historian, rather than inventing the synchronisms, had access to a synchronistic source (or sources). Sources of this nature are known from ancient Babylon and are represented by such documents as the Chronicle of the Kings from Nabonassar to Šamaš-šuma-ukin, the Chronicle of the Kings from Nabonassar to Esarhaddon, the Chronicle of Esarhaddon, the Chronicle of Nabopolassar Concerning the Fall of the Assyrian Empire, the Chronicle of the Death of Nabopolassar and the First Years of Nebuchadnezzar, and the Chronicle of Nabonidus, to name just a few. All are from the Neo-Babylonian period (c. 6th century BCE).¹⁸¹ A common formula begins each unit in these chronicles: "In the Xth year of PN, such and such happened." Assyrian sources are similar, but date events according to a year *name*, rather than a year *number* that is associated with the reign of a king. The Eponym Chronicles (one from the 18th century and one from the 7th century BCE) are the best examples. All of the

¹⁸¹ Texts, translations, and commentary on all of these are in *Ibid.*

Mesopotamian documents of this kind are written in prose, give priority to dates, and provide only brief summaries of the events that occurred on those dates.¹⁸²

If the synchronisms in the Bible are derived from a similar document (or documents) used by the author of the DH, what is the origin of the document(s)? Several past studies of the chronology of the kings have assumed that the date for the accession of a Judahite king, which mentions a specific regnal year of an Israelite king, came from a Judahite source.¹⁸³ For example, the phrase, “In the eighteenth year of King Jeroboam the son of Nebat, Abijam became king over Judah” (1 Kings 15:1), is said to come from the annals of the kings of Judah because it records the accession of a Judahite king, and because the remainder of the information in the formula (age at accession, length of reign, and mother’s name) is undoubtedly Judahite. I find this assumption odd, considering the manner in which this dating formula is used in other places in the history. For example, does the datum, “And it was in the fifth year of Rehoboam that Shishak the king of Egypt came up against Jerusalem” (1 Kings 14:25), derive from the annals of Shishak? Surely the information about Rehoboam’s fifth year does not come from an Egyptian source, but a Judahite one. Or when it is stated, “And it was in the fourth year of King Hezekiah, that is, the seventh year of Hoshea the son of Elah, the king of Israel, that Shalmaneser, the king of Assyria, came up against Samaria,” is not the usual interpretation that the datum about Hezekiah came from a Judahite source and that of

¹⁸² A fragment of a monumental inscription from 8th century BCE Jerusalem, suggests that Judah dated events according to numbered years as well. The expression “in the seventh” occurs in the second line, and may refer to the seventh year of Hezekiah. The fourth line carries the expression “in the fourth [month].” See Frank Moore Cross, “A Fragment of a Monumental Inscription from the City of David,” *Israel Exploration Journal* 51.1 (2001): 44-47.

¹⁸³ For example, Thiele, *MNHK*, 25, John H. Hayes and Paul K. Hooker, *A New Chronology for the Kings of Israel and Judah* (Atlanta: John Knox Press, 1988), 14.

Hoshea came from an Israelite one? Appealing to an argument for consistency, I find it unlikely that the synchronism (“In the [#] year of PN, PN became king”) derives from the same source as that which lists the new king’s age, length of reign, and mother. In other words, there are two different sources behind the accession formulas. *The composer/compiler combined the information about an accession, which he gleaned from a native source, with a synchronism he obtained from the opposite kingdom.* Now it is possible that he had access to a synchronistic chronicle of some kind, although he never mentions such a source among those he cites. However, even if he did, the composer of the synchronistic chronicle would have obtained this information from the same place that the Deuteronomistic compiler would have—an Israelite chronicle. In Abijam’s case, the annals of the *north* are more likely to have mentioned Abijam’s accession in the events of Jeroboam’s eighteenth year than that the annals of the *south* would have went out of their way to mention that Abijam’s accession took place in Jeroboam’s eighteenth year. For these reasons, we should see Pattern 2 of the accession notices displayed above (that is, the one without the synchronism) as the one that most likely reflects the contents of the Judahite source the author draws from. The mere existence of the second pattern indicates that the Judahite source neither desired nor needed the synchronism with Israel to provide a suitable chronological marker for the accession of its kings.

When the synchronistic notices in the accession formulas are put aside,¹⁸⁴ all differences between Pattern 1 and Pattern 2 are gone, and the information coming from the Judahite source is consistent for all the kings:

[Rehoboam] was 41 years old at his accession, and he reigned 17 years in Jerusalem..., and his mother's name was Naamah the Ammonitess (1 Kings 14:21).

[Abijam] reigned 3 years in Jerusalem, and his mother's name was Maacah the daughter of Abishalom (1 Kings 15:1-2).

[Asa] reigned 41 years in Jerusalem, and his mother's name was Maacah the daughter of Abishalom (1 Kings 15:9-10).

Jehoshaphat was 35 years old at his accession, and he reigned 25 years in Jerusalem, and his mother's name was Azubah the daughter of Shilhi (1 Kings 22:41-42).

[Jehoram] was 32 years old at his accession, and he reigned 8 years in Jerusalem (2 Kings 8:16-17).

Ahaziah was 22 years old at his accession, and he reigned 1 year in Jerusalem, and his mother's name was Athaliah, the daughter of Omri the king of Israel (2 Kings 8:25-26).

¹⁸⁴ They will be picked up again in our discussion of Royal Chronicles below.

Jehoash was 7 years old at his accession..., and he reigned 40 years in Jerusalem, and his mother's name was Zibiah from Beersheba (2 Kings 11:21-12:1).

[Amaziah] was 25 years old at his accession, and he reigned 29 years in Jerusalem, and his mother's name was Jehoaddin of Jerusalem (2 Kings 14:1-2).

[Azariah] was 16 years old at his accession, and he reigned 52 years in Jerusalem, and his mother's name was Jecoliah of Jerusalem (2 Kings 15:1-2).

[Jotham] was 25 years old at his accession, and he reigned 16 years in Jerusalem, and his mother's name was Jerusha the daughter of Zadok (2 Kings 15:32-33).

[Ahaz] was 20 years old at his accession, and he reigned 16 years in Jerusalem (2 Kings 16:1-2).

[Hezekiah] was 25 years old at his accession, and he reigned 29 years in Jerusalem, and his mother's name was Abi, the daughter of Zechariah (2 Kings 18:1-2).

Manasseh was 12 years old at his accession, and he reigned 55 years in Jerusalem, and his mother's name was Hephzibah (2 Kings 21:1).

Amon was 22 years old at his accession, and he reigned 2 years in Jerusalem, and his mother's name was Meshullemeth, the daughter of Haruz from Jotbah (2 Kings 21:19).

Josiah was 8 years old at his accession, and he reigned 31 years in Jerusalem, and his mother's name was Jedidah, the daughter of Adaiah from Bozkath (2 Kings 22:1).

Jehoahaz was 23 years old at his accession, and he reigned 3 months in Jerusalem, and his mother's name was Hamutal, the daughter of Jeremiah from Libnah (2 Kings 23:31).

Jehoiakim was 25 years old at his accession, and he reigned 11 years in Jerusalem, and his mother's name was Zebidah, the daughter of Pedaiah from Rumah (2 Kings 23:36).

Jehoiachin was 18 years old at his accession, and he reigned 3 months in Jerusalem, and his mother's name was Nehushta, the daughter of Elnathan of Jerusalem (2 Kings 24:8).

Zedekiah was 21 years old at his accession, and he reigned 11 years in Jerusalem, and his mother's name was Hamutal, the daughter of Jeremiah from Libnah (2 Kings 24:18).

The evidence indicates that one of the historians possessed a Judahite document containing specific information, and, it would seem, the document was in the form of a list, rather than a chronicle containing narratives of the exploits of the kings.¹⁸⁵ The information we have preserved from it may represent its entire contents. Evidence for this conclusion is seen in an apparent textual error in the formula recounting the accession of Asa (1 Kings 15:9-10). The clause concerning his mother's name is precisely the same as the one appearing in the previous entry concerning Abijam (1 Kings 15:1-2). It is doubtful that both Abijam and his son Asa had the same mother. More probable is that the historian or a previous copyist, when he was writing down the Abijam formula, accidentally let his eye slip down to the following entry and copied that one instead. For this to have occurred, however, the two entries must have been in close proximity. The most likely scenario is that the accession formulas were listed one right after another with little or no intervening material. The mistake could have existed already in the source document; otherwise it would have been made by whomever copied the information from the list into the text of the DH (either the Deuteronomistic Historian or the reviser of the DH).

The 19 Judahite accession formulas appear among the stereotypical comments the historian makes to open and close the accounts of the kings' reigns. In addition to the accession formulas, the introductory rubrics contain a verdict about the behavior of the said king in light of his adherence or lack of adherence to the Torah of Moses. The

¹⁸⁵ Earlier studies that argue for the existence of a Judahite and an Israelite king list that underlie the DH are: Shoshana R. Bin-Nun, "Formulas from Royal Records of Israel and of Judah," *Vetus Testamentum* 18

concluding rubrics contain a source citation, notice of death and burial, and the name of the successor. In a systematic study of these regnal formulations, Richard D. Nelson has remarked on the difference between those used for the kings up to and including Josiah, which show evidence of free variation in composition, and those who succeed Josiah, which show almost no variation.¹⁸⁶ The variation seen in the earlier formulations, Nelson attributes not only to variations in the historian's sources, but to "the natural result of the historian writing his own prose freely, using stock phrases from his everyday theological vocabulary, and developing and modifying his structural arrangement as he went along."¹⁸⁷ Nelson concludes, probably correctly, that a different author composed the formulations for the latter kings. However, Nelson's argument relies heavily on analysis of the DH's evaluations of the kings.¹⁸⁸ These evaluations are not likely to be part of the author's source citations and for our purposes should be set aside. What is interesting is that, taken on their own (without the synchronisms and evaluations), the accession formulas, which include the age of the king at his accession, the number of years of his rule, and the name of his mother, exhibit a different pattern. An examination reveals "free and random variation" within the structural arrangement for the entries from Rehoboam to Manasseh and strict uniformity from Amon to Zedekiah. The first set of entries never lists in a single entry both the mother's hometown and her father's name, while the last set always does. While we could posit that the final entries are fuller simply because there was more information available for the later kings, the absence of any variation

(1968), and William Hamilton Barnes, *Studies in the Chronology of the Divided Monarchy of Israel*, ed. Frank Moore Cross (Atlanta: Scholars Press, 1991), 137-49.

¹⁸⁶ Nelson, *Double Redaction*, 29-42.

¹⁸⁷ *Ibid.*, 35-36.

¹⁸⁸ *Ibid.*, 36.

whatsoever in the last entries is striking and suggests that they constitute an addition to the original list by a single writer. Strangely, the cut-off point is at Manasseh, not Josiah. The fact that the accession notices change their pattern in a different place (Manasseh) than where the remainder of the material in the opening and closing formulas changes its pattern (Josiah) strongly favors the supposition that the accession notices are from an independent source.

The original version of this king list (without the final six entries) is easy to date. Since it has knowledge of the length of the reign of Manasseh, it must be dated after his death. However, since the list does not include an entry for Amon, it must be dated before Amon's death. Thus the list must have been composed sometime within the two-year reign of Amon.¹⁸⁹ The uniformity in the final six entries suggests a single author for the additions, one who possessed information about the final king of Judah and who therefore would have composed all six entries after the destruction of Jerusalem in 586 BCE.

¹⁸⁹ We might at this point recall that the author of Chronicles includes similar information in his own history and employs similar wording. However, he probably did not use this king list as a source, but rather the DH itself. This is evident in the entry for Rehoboam (1 Ki 14:21; 2 Chron 12:13), which is reproduced in Chronicles verbatim from the DH, including the phrase, "the city that Yahweh had chosen out of all the tribes of Israel to put his name there," which is a Deuteronomistic phrase (cf. 1 Ki 8:16; 11:32) and therefore derives from the Deuteronomistic editor of the king list and not from the king list itself. It can also be seen in the fact that some of the Chronicler's accession formulas include a synchronism as well (e.g., 2 Chron 13:1-2), and we know that the synchronisms were combined with the information from the king lists by the Deuteronomistic editor. Some have argued that, because the names of the Queen Mothers disappear in Chronicles after Hezekiah, the Chronicler must have used a Hezekian version of the Deuteronomistic History as a source (See, e.g., Baruch Halpern and David S. Vanderhooft, "The Editions of Kings in the 7th-6th Centuries B.C.E.," *Hebrew Union College Annual* 62 [1991]: 197-99). However, because the Chronicler's entry for Hezekiah includes the total number of years he reigned (2 Chron 29:1), the DH the Chronicler used could not have been Hezekian. It must have been at least Manassean. However, we know of no Manassean edition of the Deuteronomistic History, and the evidence here presented suggests that the king list's information was lacking even in the Josianic edition. Therefore we must conclude that the Chronicler used the exilic edition of the DH and that the differences in Chronicles are not reflective of its source. The Chronicler must have omitted (consciously or unconsciously) the names of the mothers of all of the kings after Hezekiah, even though his source contained them. (That he omitted many synchronisms and Asa's accession formula entirely suggests that he was not averse to cutting out some of the information.)

That this king list was incorporated into the first edition of the Deuteronomistic History is unlikely. If that were the case, to be consistent the Historian would have written entries for the last two kings, Amon and Josiah, that included their ages at accession, their mother's names, and, for Amon, his length of reign. Both of these kings ruled during the Historian's lifetime, and the information would have been easy to obtain, even though the king list did not have it (as the evidence indicates that the list was not updated until after the reign of Zedekiah). However, he did not include the information for these two kings. Alternatively, if the first edition of the DH was written in the reign of Hezekiah, as some have suggested,¹⁹⁰ then this list could not have been in such an edition either, because it had not yet been written. These factors indicate that the Josianic Deuteronomistic Historian did not possess this Judahite king list in either its long or short form, and that the accession formulas were not put into the DH until the second edition.¹⁹¹ Dtr¹ would have read just as smoothly without them. The typical reading for the accession of kings in the first edition would have been something like this: "In the # year of PN, the son of PN the king of Israel, PN, the son of PN the king of Judah, became king, and he did what was right in Yahweh's eyes," etc. With regard to the kings after Hezekiah, the transition from king to king would have read something like this: "And PN

¹⁹⁰ E.g., H. Weippert, "Die 'deuteronomistischen' Beurteilungen der Könige von Israel und Juda und das Problem der Redaktion der Königsbücher," *Bib* 53 (1972): 301-39, M. Weippert, "Fragen des israelitischen Geschichtsbewusstseins," *Vetus Testamentum* 23 (1973): 415-42, A Lemaire, "Vers L'histoire de la rédaction des livres des Rois," *ZAW* 98 (1986): 221-36, Halpern and Vanderhooft, "The Editions of Kings in the 7th-6th Centuries B.C.E.," 179-244.

¹⁹¹ On the general historical credibility of the information from this list (i.e., the king's accession age, death age, length of reign, and age at the birth of his son), see D.N. Freedman, "Kingly Chronologies: Then and Later," in *Eretz-Israel XXIV, Avraham Malamat Volume* (Jerusalem: Israel Exploration Society, 1993): 41*-65*.

lay down with his fathers, and PN his son reigned in his stead, and he did what was bad in Yahweh's eyes," etc.¹⁹²

One question that arises in connection with these conclusions is: Were the final six entries composed specifically for the king list, or were they composed specifically for the Deuteronomistic History? In other words, did the reviser of the DH use a king list that had already been updated through Zedekiah, or did he possess the original king list that ended at Manasseh and then add in the final six entries to the DH himself? This question is probably unanswerable and, for my purposes here, does not really matter. However, it is reasonable to suppose that the reviser of the History sought out the information about the final kings from whatever external sources he could find. This list (in updated form) may have been one of them.

If we look at the three kings who preceded Rehoboam (Saul, David, and Solomon), we find that the first two kings have accession formulas that fall into the pattern found in the Judahite king list:

Saul was [] years old at his accession, and he reigned 2 years over Israel (1 Samuel 13:1).

David was 30 years old at his accession, and he reigned 40 years. He reigned over Judah 7 years in Hebron, and he reigned over all Israel and Judah 33 years in Jerusalem (2 Samuel 5:4-5).

It seems probable therefore that the list went as far back as Saul. Problems associated with these early entries, however, suggest that the scroll that contained the king list was damaged at the beginning. Saul's accession age is missing in most manuscripts. David's

¹⁹² Cf. 2 Chron 14:1-2.

accession formula is in good shape. It is longer than the rest, but naming the city of rule along with the length of the rule is customary for this list. The second part of David's accession formula is actually related a second time in the DH in his closing formula (2 Kings 2:11). Solomon's entry, however, is completely missing; no accession formula is present in the DH. In his closing formula there is the statement that he reigned for 40 years (1 Kings 11:42). However, this statement does not conform to the pattern of the other formulas, and an attribution of 40 years to Solomon is somewhat suspect, as the number is the round figure usually used to signify a generation.¹⁹³ It may be that the king list was damaged where Solomon's formula was written, and the reviser of the DH had to make an educated guess.

Turning to the Israelite accession formulas in the DH, we find far less detail than we do in the Judahite formulas. There are two patterns, spread more or less randomly through the History:

- 1) בשנת # (שנה) ל PN (מלך יהודה) מלך PN (בן PN) על-ישראל (בתרצה/בשמרון) # שנים

In the [#] (year) of [PN], (the king of Judah), [PN] (the son of PN) became king over Israel (in [Tirzah or Samaria]) for [#] years.

- 2) PN (בן PN) מלך על-ישראל בשנת # (שנה) ל PN מלך יהודה וימלך (על-ישראל) # שנים

And PN the son of PN became king over Israel in the [#] (year) of PN the king of Judah, and he reigned (over Israel) [#] years.

¹⁹³ See above, Chapter Two, Section C and Section A.3 of the present chapter.

For the most part, these formulas correspond to the first phrase in the Pattern 1 Judahite accession formula as it appears in the DH. The only notable difference between the two Israelite patterns is the inversion of the first two clauses. Of note also is that the lengths of reign are found at the end of the formulas in all instances. As in the case of the Judahite accession formulas, it is best to understand the synchronisms here to come from the chronicles of the opposite kingdom, and here it would mean those of Judah. The only information, then, to have come from an Israelite source in these formulas is the length of the king's reign (and perhaps the name of the capital city, although this information is not always provided, and the capitals, Tirzah and Samaria, like Jerusalem, were no doubt well known).

Apart from two kings (Jeroboam and Jehu), the reign length for all the kings appears at the end of each accession synchronism. For Jeroboam and Jehu, the reign length appears at the end of their closing formulas (1 Ki 14:19-20; 2 Ki 10:34-36). This difference is attributable to the fact that neither of these kings has an accession synchronism to which a reign length could be attached. The reason for the lack of an accession synchronism for these two kings is clear: no synchronism with a Judahite monarch was recorded in the Judahite annals for either king. For Jeroboam, this was no doubt because he was the first king of Israel and the custom had not yet been adopted (and his kingship may not even have been recognized in Judah at the time). For Jehu, a synchronism could not have existed because when he began to rule, he had just slain the king of Judah, and it was unclear who the next king would be. In fact, a legitimate Judahite monarch would not sit on the throne for several years to come. The fact that the reign lengths are included for Jehu and Jeroboam, even though they do not have

accession synchronisms, suggests that the reign lengths derive from a different source. Since the first edition of the DH probably did not include the lengths of the reigns of the monarchs of *Judah*, it would be strange if the lengths of the reigns of the monarchs of *Israel* were included. More probable is that they were likewise absent in the first edition and later added into Dtr² by the reviser of the history to match what he did for Judah.

As in the case of the Judahite kings, the exilic reviser of the history may have had at his disposal a list of the names of the kings of Israel and the total years of their reigns in a separate document. Although it is possible that he calculated the reign lengths himself, simply by tallying the totals he worked out from the synchronisms that were already present in the History, the synchronisms do not actually allow one to narrow down reign totals to within a year's accuracy, and there are contradictions between the synchronisms and the reign totals.¹⁹⁴ Moreover, his knowledge of the precise length of reigns less than a year long (Zechariah, Shallum) makes it improbable that the reign totals were calculated from the synchronisms. The data had to be recorded somewhere, and the reviser gained access to this data. Whatever the case, the supplementary information is as follows:

Jeroboam 22 yrs (1 Kings 14:20)
 Nadab 2 years (1 Kings 15:25)
 Baasha 24 yrs (1 Kings 15:33)
 Elah 2 yrs (1 Kings 16:8)
 Zimri 7 days (1 Kings 16:15)
 Omri 12 years (1 Kings 16:23)
 Ahab 22 years (1 Kings 16:29)
 Ahaziah 2 years (1 Kings 22:52)
 Jehoram 12 years (2 Kings 3:1)
 Jehu 28 years (2 Kings 10:36)
 Jehoahaz 17 years (2 Kings 13:1)

¹⁹⁴ See discussion below.

Joash 16 years (2 Kings 13:10)
 Jeroboam 41 years (2 Kings 14:23)
 Zechariah 6 mos. (2 Kings 15:8)
 Shallum 1 mo. (2 Kings 15:13)
 Menahem 10 years (2 Kings 15:17)
 Pekahiah 2 years (2 Kings 15:23)
 Pekah 20 years (2 Kings 15:27)
 Hoshea 9 years (2 Kings 17:1)

c. Royal Chronicles

We have observed that the synchronistic formulations in the DH exhibit a uniform pattern throughout: “In the [#] year of PN, [a certain event happened].” The events include invasions, wars, significant cultic innovations or reforms, and, as mentioned above, accessions of rulers in the sister kingdom. Such a construction demonstrates that the dates are from some sort of chronicle, and since the dates are associated with the kings of both kingdoms, it is best to posit two such chronicles, a Judahite and an Israelite one. These are no doubt to be equated with *The Scroll of the Affairs of the Days for the Kings of Judah* and *The Scroll of the Affairs of the Days for the Kings of Israel* that the historian cites. Moreover, they are clearly an integral part of the first edition of the DH.

In MT, of the 32 accession synchronisms in the DH, three set themselves apart (1 Kings 16:10; 2 Kings 1:17; 2 Kings 15:30). These formulas refer to the accessions of Israelite kings. They could not possibly derive from the author’s Judahite chronicle, as do the others in the series, for the following reasons: 1) They do not conform to the known patterns of the synchronistic accession formulas; 2) They are doublets of existing synchronistic accession formulas; and, 3) in the case of the latter two, they contradict the

data already found in other synchronistic accession formulas. Also of note is that none of these formulas are attested in LXX.

The customary wording we should expect in the description of an Israelite accession is: “In the [#] (year) of [PN], (the king of Judah), [PN] (the son of PN) became king over Israel in [Tirzah or Samaria],” or the inverted pattern, “And PN the son of PN became king over Israel in the [#] (year) of PN the king of Judah.” Instead, in these three verses we find the statement, “And PN became king in his stead, in the [x] year of PN, the son of PN (the king of Judah).” (In the case of 1 Kings 16:10, the wording is inverted.) It is interesting that these three verses are constructed very similarly.

The datum at 2 Kings 1:17 is a doublet of 2 Kings 3:1 and directly contradicts the datum found there, which does exhibit the typical pattern for accession formulas.

2 Ki 3:1

And Jehoram the son of Ahab became king over Israel in the 18th year of Jehoshaphat the king of Judah, and he reigned 12 years.

2 Ki 1:17

And Jehoram became king in his stead, in the 2nd year of Jehoram the son of Jehoshaphat the king of Judah.

Of interest is that, although 2 Kings 1:17 is absent in LXX, the chronological information it contains *is* found in the Greek text in a verse not contained in MT (2 Kings 1:18a). As

will be argued below, the datum is an invention of the LXX editors, so it likely reached MT through cross-fertilization.¹⁹⁵

The datum at 2 Kings 15:30 is a doublet of 2 Kings 17:1 and directly contradicts the datum found there, which does exhibit the typical pattern for accession formulas.

2 Ki 17:1

In the 12th year of Ahaz the king of Judah, Hoshea the son of Elah became king in Samaria over Israel for 9 years.

2 Ki 15:30

And he [Hoshea] became king in his stead, in the 20th year of Jotham the son of Uzziah.

2 Kings 15:30 is absent in LXX.

The datum at 1 Kings 16:10 does not contradict its doublet (1 Kings 16:15), but it fits the pattern of the other anomalous notices and not that of the typical accession formulas. The Old Greek version of LXX (the earliest) does not have it. I would suggest that all three of these notices found their way into the text near the end of the fluid period in MT's transmission history (i.e., sometime before the destruction of the Second Temple in 70 CE), but long after Dtr² was published, and were put there to harmonize contradictory figures in the History¹⁹⁶ or to add clarification (as in the case of 1 Kings 16:10).

¹⁹⁵ In an attempt at harmonization, sometimes the ancient scribes assimilated readings from other manuscript traditions into their texts. The Greek *Kaige* and Hexaplaric recensions, for example, were made to conform more closely to MT. See James Donald Shenkel, *Chronology and Recensional Development in the Greek Text of Kings* (Cambridge: Harvard University Press, 1968), 11-21.

¹⁹⁶ This will be discussed in more detail below.

By themselves, the synchronisms taken from either the Judahite chronicle or the Israelite chronicle are not sufficient to construct a chronology for the kings of either kingdom. Together, however, they may be of some use. If we can discern how the systems of measurement used in each of the chronicles relate to one another, we can synchronize the dates and arrive at reign lengths for many of the kings. In order to do this, we have to know the answer to one question: Which system of reckoning (post-dating or antedating) was employed in the calculations reflected in each source?

In an accession-year system (post-dating), the king's first year begins on the first new year's day after his accession. His reign may begin several months before that day, but that entire period prior to his first year is counted as the final year of his predecessor. Reign totals based on an accession-year system are equivalent to the actual years of reign, because the first year is not counted. In a non-accession-year system (antedating), the year of a king's accession is counted as his first year, even if he does not reign the entire year. Both he and his predecessor receive credit for that year.¹⁹⁷ Reign totals based on a non-accession-year system are one year greater than the actual years of reign, because the first year is counted.

The Judahite chronicle itself leaves us with no clues, but it may be significant that the Judahite king list assumes an accession-year system (post-dating). The date for the death of Josiah may be fixed in the year 609 (see below), and if we take the reign totals of his successors (Jehoahaz, 3 months, Jehoiakim, 11 years, Jehoiachin, 3 months, and Zedekiah, 11 years) from the king list and add them up as they are (22 years and 6

¹⁹⁷ See Eduard Meyer, "Principien der rechnung nach Königsjahren," in *Forschungen zur alte Geschichte* (Halle: Niemeyer, 1899) II: 440-53, Finegan, *Handbook of Biblical Chronology*, 75.

months), assuming an accession-year system, we arrive at the date 587 or 586 for the end of the monarchy (which is in keeping with extrabiblical evidence). However, if we assume a non-accession year system, we arrive at the date 589 or 588, which years fall short of the date we expect the city to have fallen. In another exercise, if one accepts the argument that Isaiah 14:28 refers to the death of Assyrian king Tiglath-pileser III in the same year as (or perhaps the year before) the death of King Ahaz, we can put the accession of Hezekiah in 727 or 726. Using the same method of calculation as above and assuming an accession-year system, we can add up the reign totals for Hezekiah through Zedekiah (a total of 139 years and 6 months) and arrive at a date between 588 and 586 for the destruction of Jerusalem. However, if we assume a non-accession year system, we come short and arrive at a date between 594 and 592 for the destruction of Jerusalem, a date which we cannot accept. The fact that the Judahite king list assumes an accession-year system suggests that, at least in the latter days of the monarchy in Judah, an accession-year system was used. How early this practice was begun is unknown, but since the Judahite royal chronicle used by the Deuteronomistic Historian would have been a late monarchic document, we should expect that it too assumed an accession-year system.

The Israelite royal chronicle used for the first edition of the DH points to a non-accession year system (antedating). Jehu took the throne of Israel at the same time that Athaliah usurped the throne of Judah (2 Kings 9:27-28; 11:1). The Historian states that Athaliah ruled Judah for 6 years (this figure is not from the Judahite king list). The chronicle puts the accession of Jehoash of Judah in the 7th year of Jehu (2 Kings 12:2).

Both of these figures can be correct only if Jehu's 7th year marked 6 years of Jehu's rulership. Only in a non-accession year system would this be true.

We can corroborate these conclusions if we make a comparison between the reign totals used in the king list from Judah with the one from Israel. Knowing that Rehoboam and Jeroboam began their reigns at approximately the same time, we can use the year of their accession as a point of departure for the two lists. Another date useful to yoke the two lists at a given point would be that for the accession of Jehu, which is to be equated with the date for the deaths of Jehoram of Israel and Ahaziah of Judah. It is interesting that the Judahite king list separates the accession of Rehoboam and the death of Ahaziah by 79 years. However, the Israelite king list separates the accession of Jeroboam and the death of Jehoram by 86 years. The two lists do not coincide if we assume accession-year systems in both of the kingdoms. However, if we posit a non-accession year system in Israel, the total years separating the two events would be reduced to 79 years and match the total years given in the Judahite list.¹⁹⁸ This is strong evidence for both an accession-year system in Judah and a non-accession year system in Israel. This is not to say that Judah's use of an accession-year system throughout the entire monarchy was a historical reality, or even that the numbers in the king list are accurate, only that, by the reckoning used in the exilic king list, an accession-year system is assumed throughout. Similarly, Israel may or may not have used the non-accession year system, but the king list appears to assume it. To be sure, the synchronisms from the chronicles may not reflect the same system as the king lists, but the king lists tell us something about late monarchic practice, and the chronicles are from that period.

With the knowledge that the regnal new year is likely to have begun in the autumn in Judah and in the spring in Israel (see Chapter One, Section D.2.d.), and that Judah used an accession-year system and that Israel used a non-accession year system, we can construct a chronology using only the synchronisms and derive regnal totals to compare to those given in the king lists. I will use the data from MT. The readings in MT may be somewhat defective, but at this stage of the study, there is no need to delve into serious textual criticism. The purpose of this exercise is merely to provide a general comparison between the reign lengths assumed by the two sources. The results we achieve from this exercise will not be precise as we might like them to be. Because the regnal years of the two kingdoms are out of sync (that is, they begin at different times of the year), we can narrow down the reign totals only to within three years. Moreover, since there is no synchronism for Jehu, it is not possible to calculate the length of Joram's reign from the synchronisms alone. Neither is it possible to figure the length of the reign of Ahaziah, the king of Judah. Moreover, no synchronisms exist after the reign of Ahaz. We are thus left with two floating chronologies, one lasting from the accessions of Rehoboam and Jeroboam at the beginning of the divided kingdom to the accession of Ahaziah, and another from the "accessions" of Athaliah and Jehu to the fall of Samaria. The reign of Ahaziah (however many years) would fall between these two chronologies.

A comparison between the reign lengths assumed in the pre-exilic chronicles and those provided by the exilic Judahite king list proves interesting.

¹⁹⁸ This is noted by Thiele, *MNHK*, 23-25.

Royal Chronicles

Rehoboam (16-18 years)

Abijam (1-3 years)

Asa (40-42 years)

Jehoshaphat (21-23 years)

Jehoram (5-7 years)

Ahaziah (?)

Jehoash (37-39 years)

Amaziah (26-28 years)

Azariah (52-54 years)

Jotham (14-16 years)

Ahaz (13-15 years)

King List

Rehoboam (17 years)

Abijam (3 years)

Asa (41 years)

Jehoshaphat (25 years)

Jehoram (8 years)

Ahaziah (1 year)

Jehoash (40 years)

Amaziah (29 years)

Azariah (52 years)

Jotham (16 years)

Ahaz (16 years)

There is some correspondence between the two sources. Although some of the differences are slight, the chronicles' numbers cannot be stretched any further. The reigns of Jehoshaphat, Jehoram, Jehoash, Amaziah, and Jotham all fall at least one year short of the total in the king list. Still, the reign lengths in the chronicles are so very close to the reign lengths in the king list. It is almost as if the chronicles are trying to harmonize themselves with the king list, but cannot quite achieve their goal.

Now it is true that the divergences between the two sources can be harmonized if we assume co-regencies or overlaps. In other words, if, for example, Jehoshaphat is understood to have begun ruling within the lifetime of his father Asa and did so for at

least 2 years before he became sole ruler, then we could accept both the figures provided. The chronicles would indicate his kingship as sole ruler, and the king list would provide his total years of rule including the co-regency. Some have argued for the existence of co-regencies in Israel and Judah,¹⁹⁹ citing some indirect evidence that points to such a practice. For example, the narratives indicate that Solomon was crowned king when his father David was still alive (1 Kings 1-2); in MT, Jehoshaphat appears to have crowned his son Jehoram in his own lifetime (2 Kings 8:16); and Azariah's son Jotham seems to have been given executive powers during the lifetime of his father (2 Kings 15:5). We should not place too much emphasis on these examples, however, especially since Solomon and David's situation is portrayed as unusual, the text mentioning Jehoram's coronation in the reign of Jehoshaphat is most likely corrupt,²⁰⁰ and Azariah is not said to be made king during the reign of his father, but is still referred to as "the king's son."²⁰¹ It would be a mistake to posit a co-regency simply to harmonize conflicting data between two or more sources. One thing is certain: The king lists and the royal chronicles themselves give no indication of co-regencies.

Here is a comparison of the figures for Israel:

Royal Chronicles	King List
Jeroboam I (24-26 years)	Jeroboam I (21 years)
Nadab (1-2 years)	Nadab (1 year)
Baasha (16-18 years)	Baasha (23 years)

¹⁹⁹ E.g., Ibid., 32.

²⁰⁰ The phrase "and Jehoshaphat was king of Judah" is omitted in some mss. and many codices of LXX. It is probably a case of dittography.

²⁰¹ See Hayes and Hooker, *A New Chronology for the Kings of Israel and Judah*, 12, Hughes, *Secrets of the Times*, 99-107.

Elah (5-7 years)	Elah (1 year)
Zimri (less than a year)	Zimri (7 days)
Omri (12-14 years)	Omri (11 years)
Ahab (19-21 years)	Ahab (21 years)
Ahaziah (1-2 years)	Ahaziah (1 year)
Joram (?)	Joram (11 years)
Jehu (28-30 years)	Jehu (27 years)
Jehoahaz (13-15 years)	Jehoahaz (16 years)
Joash (16-18 years)	Joash (15 years)
Jeroboam II (63-65 years)	Jeroboam II (41 years)
Zechariah (1-2 years)	Zechariah (6 months)
Shallum (less than a year)	Shallum (1 month)
Menahem (10-12 years)	Menahem (9 years)
Pekahiah (1-3 years)	Pekahiah (1 year)
Pekah (27-29 years)	Pekah (19 years)
Hoshea (8 years)	Hoshea (8 years)

In this chart, one year was subtracted from each of the reign totals provided by the king list with the understanding that Israel used an antedating system. Although the figures from each source tend to be close, there are many disagreements. There is a significant discrepancy with regard to the reign of Jeroboam II, the chronicle assuming a highly improbable reign of 63-65 years. (It is doubtful that Jeroboam served some 22-24 years as coregent.) Another significant difference is seen in the reign of Pekah, the chronicles' figure again being much higher.

The evidence that points to the existence of a chronology associated with documents not used in the first edition of the Deuteronomistic History best explains the contradictory data. The historiographic works, containing the synchronisms used and

cited in the first edition, present a different chronology than that of the king lists. In MT the reign lengths for the kings of Judah obtained from the synchronisms correspond so much more closely to the king list than the reign lengths for the kings of Israel. Why is that? All the reign lengths for the kings of both kingdoms have been calculated from the same repository of data. I can see only two possible reasons for this: either because Judah's king list is more reliable than Israel's (which is not likely, since the Israelite king list's figures seem more reasonable than the chronicles'), or there was a deliberate effort on the part of someone to make sure that the synchronisms of the Judahite kings corresponded to the stated reign lengths, while Israel was not as important. It is my contention that this was, in fact, the case, and that in an earlier version of the text, the data from the chronicles and the king lists diverged even more greatly than they do now.

d. Textual Difficulties in Kings

Any attempt at understanding the systems employed in the royal chronicles, or any of the chronological sources, must be based on a reliable text, that is, one containing an accurate set of numbers. By "accurate," I do not necessarily mean *historically* accurate. I mean that we want the synchronisms as they would have appeared in the first edition of the Deuteronomistic History, just as we would wish to know the numbers from the king lists as they would have appeared in the second edition of the History. We also are interested in knowing the data as they appeared in the sources prior to their incorporation into the History (if different). We have in our possession two chief textual witnesses to the royal chronicles, as we do to the king lists, one witness associated with the texts in the Masoretic tradition, and the other with the texts in the Greek tradition. The

two text traditions differ very little in their representation of the data from the king lists. With regard to the information from the royal chronicles, however, significant variants in the figures associated with the kings of Israel and Judah occur in the various manuscripts.

The texts of Kings in the MT family are fairly consistent, and so a clear reading of the figures in the MT tradition is possible. However, the recensions of LXX are somewhat varied. Nevertheless, it is possible to determine the earliest forms of the Greek text tradition. The pertinent studies are those of de Lagarde,²⁰² Barthélemy,²⁰³ and Shenkel,²⁰⁴ which understand there to have been a single translation of the books of Samuel and Kings into Greek. All the versions of the Greek text, therefore, are not new translations, but simply variant text forms of a single Old Greek translation. This theory has more to commend it than the opposing one, commonly associated with Kahle,²⁰⁵ that the Septuagint was formed through a process of selective canonization of several different translations.

In this study, references to the data in LXX will be primarily to the Old Greek translation (henceforth OG) of Samuel-Kings, which derives from an Egyptian Hebrew text that existed sometime between the 4th and 3rd centuries B.C.E. Our best witness to the OG is Codex Vaticanus, but only in 1 Samuel, 2 Sam 1:1-9:13, and 1 Kings 2:12-21:43. For the sections of OG that are wanting in Codex Vaticanus, our recourse is to the Lucianic text, which, as has been demonstrated by others, contains an ancient stratum

²⁰² Paul de Lagarde, *Ankündigung einer neuen Ausgabe der griechischen Übersetzung des alten Testaments* (Göttingen: 1882).

²⁰³ Dominique Barthélemy, *Les devanciers d'Aquila*, Supplements to Vetus Testamentum, vol. 10 (Leiden: Brill, 1963).

²⁰⁴ Shenkel, *Chronology and Recensional Development in the Greek Text of Kings*.

²⁰⁵ Paul Kahle develops his view principally in the following works: Paul Kahle, "Untersuchungen zur Geschichte des Pentateuchtextes," *Theologische Studien und Kritiken* 1.88 (1915), Paul Kahle, "Die

datable to the 2nd or 1st century B.C.E. that preserves some of OG, although, as we shall see, rather imperfectly. The manuscripts used in this study as witnesses of the Lucianic text are the miniscules b, o, and e₂.²⁰⁶

Our conclusion that the first edition of the DH did not contain the reign lengths of the kings assists us in ascertaining the original form of the text that gave rise to both the MT and the OG text traditions. It would appear that the variants arose after the reign totals were added to the History, when later editors noted the contradictions between the chronologies inherent in the synchronisms and the king lists and tried to fix the discrepancies.

The first example of such an adjustment can be seen in a comparison between the figures in MT and LXX with regard to the reign of Jeroboam and his contemporaries. MT has a synchronism for the accession of Asa in the 20th year of Jeroboam (1 Kings 15:9-10). LXX places Asa's accession in Jeroboam's 24th year (1 Kings 15:8-10). The Israelite king list gives Jeroboam a total reign of 22 years. LXX's figure is irreconcilable with the reign total of 22 years. It therefore is more likely to be original. The variants arose this way: the original synchronism for Asa's accession was the 24th year of Jeroboam. The figure of 22 years, taken from the king list, was inserted into the DH by its exilic reviser. Later scribes noticed that Jeroboam could not have had a 24th year if he reigned only 22 years. The problem was handled differently in each text tradition. An MT scribe reduced the synchronism to the 20th year to alleviate the difficulty. An LXX scribe simply

Septuaginta: Principielle Erwägungen," in *Festschrift Otto Eissfeldt* (Halle: 1947), idem, *The Cairo Geniza*, 2 ed. (Oxford: 1959).

²⁰⁶ b = Rome, Chigi, R. vi. 38 (10th century CE) and Rome, Vat. Gr. 330 (14th century CE); o = Paris, Bibl. Nat., Coislin Gr. 3 (12th-13th century CE); e₂ = London, B.M. Reg. i. D. 2 (13th century CE).

removed the reign total of Jeroboam from the text (the datum is absent in LXX). (See Table 4.1.)

One might wonder why the editors of proto-MT reduced the synchronism by four years (24th to 20th) when they only needed to reduce it by two (24th to 22nd). The answer appears to lie in the number of the regnal years attributed to Asa's predecessor, Abijam of Judah, whose reign overlapped with Jeroboam's. Abijam is said, in both traditions, to have taken the throne in the 18th year of Jeroboam. Abijam's reign length, according to the synchronisms in LXX, would have to be 6-7 years (18th to 24th year of Jeroboam). According to the synchronisms in MT, Abijam's reign length would be 2-3 years (18th to 20th year of Jeroboam). The reign total of Abijam in LXX is 6 years, and it is 3 years in MT. If, as argued in the previous paragraph, MT's synchronism for the accession of Asa (20th year of Jeroboam) is secondary, then the reign length of Abijam indicated by the synchronisms is shorter in MT than it once was. They originally would have suggested a 6-7 year reign for Abijam. If the proto-MT scribes tried to accommodate the king list's reign length for Jeroboam by adjusting a synchronism, they also may have tried to accommodate the king list's figure for Abijam (presumably 3 years, according to MT). Indeed, the scribes could have accommodated *both* Jeroboam's and Abijam's reign lengths by adjusting only one synchronism. If the synchronism for Asa's accession were reduced from the 24th year of Jeroboam only to the 22nd year, then Jeroboam's reign length of 22 years would be harmonized with the synchronisms, but the length of Abijam's reign indicated by the synchronisms would be 4 years, overshooting the king list's total by 1 year. However, by reducing the synchronism for Asa's accession even further to Jeroboam's 20th year, the proto-MT editors were able to accommodate both

Jeroboam's reign total of 22 years *and* Abijam's reign total of 3 years. The editors of OG handled the discrepancy in another way. They left the synchronisms alone and increased the length of Abijam's reign from 3 years to 6 years. (They had already omitted Jeroboam's reign total.)

Table 4.1: Readings for Abijam, Asa and Jeroboam

	Archetype	LXX	MT
Royal Chronicles	Abijam accedes in 18 th of Jeroboam Asa accedes in 24 th of Jeroboam	Abijam accedes in 18 th of Jeroboam Asa accedes in 24 th of Jeroboam	Abijam accedes in 18 th of Jeroboam Asa accedes in 20th of Jeroboam
King List	Jeroboam rules 22 years Abijam rules 3 years	[Jeroboam's reign length omitted] Abijam rules 6 years	Jeroboam rules 22 years Abijam rules 3 years

The next example of an adjustment made after the reign totals were added to the History is seen in a discrepancy between MT and LXX with regard to the synchronism for the accession of Elah of Israel. MT places Elah's accession in the 26th year of Asa. LXX places the event in the 20th year of Asa. Both traditions agree that Elah's predecessor Baasha took the throne in Asa's 3rd year. So the reign length for Baasha in MT is somewhere between 23 and 25 years. In LXX, a reign length of 17-19 years is assumed. Considering that the reign length given for Baasha is 24 years, we should take the Greek synchronism, which contradicts this figure, as original. When an editor of proto-MT saw that the synchronism would not allow Baasha a reign of 24 years, he pushed Elah's accession forward to the 26th year of Asa to accommodate the new information.

Table 4.2: Readings for Baasha and Elah

	Archetype	LXX	MT
Royal Chronicles	Baasha accedes in 3 rd of Asa Elah accedes in 20 th of Asa	Baasha accedes in 3 rd of Asa Elah accedes in 20 th of Asa	Baasha accedes in 3 rd of Asa Elah accedes in 26th of Asa
King List	Baasha rules 24 years	Baasha rules 24 years	Baasha rules 24 years

The 12 years given to Omri by the reviser caused some serious problems, and both text traditions had difficulty in rectifying them (and neither is entirely successful). In the original text (1 Kings 16:23), the Deuteronomistic Historian placed Omri's succession in the 31st year of Asa and mentioned that he had already reigned 6 years in Tirzah. These 6 years²⁰⁷ no doubt coincided with the rule of Omri's rival Tibni (1 Kings 16:21-22). Counting back 6 years from the 31st of Asa we arrive at the 26th of Asa for the beginning of the parallel reigns of Omri and Tibni (See Table 4.3.)

Table 4.3: Totalling the Years of Omri

Judah	Israel	Count of years (inclusive)	Count of years (exclusive)
25 th of Asa	Omri and Tibni	1	0
26 th of Asa	Omri and Tibni	2	1
27 th of Asa	Omri and Tibni	3	2
28 th of Asa	Omri and Tibni	4	3
29 th of Asa	Omri and Tibni	5	4
30 th of Asa	Omri and Tibni	6	5
31 st of Asa	1 st of Omri	7	6
32 nd of Asa	2 nd of Omri	8	7
33 rd of Asa	3 rd of Omri	9	8
34 th of Asa	4 th of Omri	10	9
35 th of Asa	5 th of Omri	11	10
36 th of Asa	6 th of Omri	12	11
37 th of Asa	7 th of Omri	13	12
38 th of Asa	8 th of Omri	14	13

²⁰⁷ The 6 years are counted inclusively, as they are a calculation of the Historian (actual regnal totals were not in the original edition of the DH). Even if this were a regnal total from an Israelite source, the northern kingdom used antedating, and therefore counted inclusively. However, keep in mind that, while in reality, Omri's first regnal year would also have been Tibni's final year, this is not so when counting. The custom, when putting together two inclusively counted blocks of time, is not to overlap (see Chapter Two).

However, the reign length of 12 years makes no sense in the context of the narrative about Omri. If the 12 years are counted from the beginning of Omri's rule in Tirzah (the 25th of Asa), the 12 years fall short of the 38th year of Asa, in which Omri is supposed to have died. If the 12 years are counted from the beginning of Omri's rule in Samaria (the 31st year of Asa), the 12 years overextend the 38th year of Asa. In other words, the archetypal reading did not accommodate the 12-year reign length.

The MT and LXX traditions handled the matter in different ways. It would appear that *none* of the witnesses preserve the original date for the rise and fall of Zimri, which was the year that Omri began his rule in contest with Tibni. If it began 6 years prior to the 31st year of Asa, as 1 Kings 16:23 suggests, then the assassination of Zimri would have been placed around the 25th year of Asa. In the Old Greek text, the synchronism for the rise and fall of Zimri was simply omitted (1 Kings 16:15). This did not help a great deal, since the lengths of the reigns of Elah and Zimri were still in the text and would indicate that Omri began ruling in Samaria in the 29th year of Asa.²⁰⁸ Nevertheless, it made the problem less obvious. Of greater concern was making Omri's rule equal 12 years. The archetypal text put Omri's accession in the 31st year of Asa, and so this datum was accepted. To make his total years 12, the editor counted forward 12 years and saw that Omri's death would have had to occur, not in the 38th year of Asa, but in the 2nd year of Jehoshaphat. Thus he moved Omri's death forward 4 years.

The proto-MT editors had to account for an additional problem they created earlier when they moved Elah's accession from Asa's 20th year to his 26th year (see

above), because the new synchronism would have conflicted with the original date for the fall of Zimri (25th year). So first they pushed the accession of Zimri to the 27th year of Asa, allowing Elah 2 inclusive years to coincide with the king list. At this point, only some 4 years separated Omri's assassination of Zimri and his ascendancy to the rule of all Israel in Asa's 31st year, but at least the total of Omri's years now equaled 12. The editors could have changed Omri's accession date to accommodate the 6 years of co-rule with Tibni, but they chose the path of least adjustment and decided to ignore the problem.

In the Lucianic tradition, the figure of 2 years for the reign of Elah prompted a later editor to place Zimri's accession two years after Elah's accession, that is, in the 22nd year of Asa. In this text, some 9 years separated Omri's assassination of Zimri and his ascendancy to the rule of all Israel (3 years more than the 6 it should have been). However, the matter with Omri and his 6-years in Tirzah were too difficult to accommodate, so the editor left the rest alone.

²⁰⁸ OG attributes 2 years to Elah and 7 years to Zimri (1 Kings 16:8, 15).

Table 4.4: Counts for Omri Assumed in the Manuscripts

Years of Asa	Archetype	MT	OG and L
25 th of Asa	Omri and Tibni	1 st of Elah	
26 th of Asa	Omri and Tibni	1 st of Zimri/1 st of	
27 th of Asa	Omri and Tibni	Omri	
28 th of Asa	Omri and Tibni	2 nd of Omri	
29 th of Asa	Omri and Tibni	3 rd of Omri	
30 th of Asa	Omri and Tibni	4 th of Omri	
31 st of Asa	1 st of Omri	5 th of Omri	1 st of Omri
32 nd of Asa	2 nd of Omri	6 th of Omri	2 nd of Omri
33 rd of Asa	3 rd of Omri	7 th of Omri	3 rd of Omri
34 th of Asa	4 th of Omri	8 th of Omri	4 th of Omri
35 th of Asa	5 th of Omri	9 th of Omri	5 th of Omri
36 th of Asa	6 th of Omri	10 th of Omri	6 th of Omri
37 th of Asa	7 th of Omri	11 th of Omri	7 th of Omri
38 th of Asa	1 st of Ahab	1 st of Ahab	8 th of Omri
39 th of Asa	2 nd of Ahab	2 nd of Ahab	9 th of Omri
40 th of Asa	3 rd of Ahab	3 rd of Ahab	10 th of Omri
1 st of Jehoshaphat	4 th of Ahab	4 th of Ahab	11 th of Omri

The length of the reign of Omri caused other difficulties. Both MT and LXX decided to forget about the 6 years in Tirzah and focus on the 12-year reign length. MT decided that the 12 years should count from the 27th year of Asa, when Omri was supposed to have assassinated Zimri, and LXX decided that the 12 years should count from the 31st year of Asa, when Omri took Samaria. Both of their synchronisms for the accession of Omri's son Ahab reflect these respective understandings. MT places Ahab's accession 12 years after the 27th year of Asa in the 38th year of Asa (1 Kings 16:29). LXX places Ahab's accession 12 years after the 31st year of Asa in the 2nd year of Jehoshaphat (1 Kings 16:29). Which of the synchronisms is correct? Is either? One might be quick to discard MT's reading, since it created the artificial synchronism in the 27th year of Asa, from which it counts the 12 years. On the other hand, since MT ceases its consistent adjustments to the synchronisms at this point, it is possible that once it arrives at Asa's 38th year, it has been able to reconcile the figures that were given it and does not need to

make any more alterations. The 12-year reign fits. So far the Greek text has been reluctant to change the synchronisms, but the perfect fit of 12 years between the 31st year of Asa and the 2nd year of Jehoshaphat arouses suspicion, and from this point the Greek text does not prove as reliable when it comes to the synchronisms, suggesting that a different method of accommodating the reign totals is at work. Keeping in mind that both MT and LXX place Omri's accession in the 31st year of Asa, and LXX is the one whose synchronism makes Omri's reign an even 12 years from that date, I opt for MT's reading for the death of Omri. The most likely scenario is that Omri's official reign in Samaria ran from the 31st to the 38th year of Asa (7-8 years) and that, after the reviser added in the 12-year datum, an editor in the Greek tradition moved the latter synchronism forward to the 2nd year of Jehoshaphat to accommodate the new figure.

Table 4.5: Readings for Zimri, Tibni, Omri and Ahab

	Archetype	LXX (OG)	MT
Royal Chronicles	Zimri accedes and dies in [25 th] of Asa Tibni and Omri reign 6 years Omri accedes in 31 st of Asa Ahab accedes in 38 th of Asa	[Zimri synchronism omitted] Tibni and Omri reign 6 years Omri accedes in 31 st of Asa Ahab accedes in 2nd of Jehoshaphat	Zimri accedes and dies in 27th of Asa Tibni and Omri reign 6 years Omri accedes in 31 st of Asa Ahab accedes in 38 th of Asa
King List	Zimri reigns 7 days Omri reigns 12 years	Zimri reigns 7 years Omri reigns 12 years	Zimri reigns 7 days Omri reigns 12 years

LXX's adjustment to the date of Ahab's death had repercussions. In MT, Ahab rules from the 38th year of Asa to the 17th year of Jehoshaphat (20-22 years). In LXX, Ahab rules from the 2nd year to the 24th year of Jehoshaphat (21-23 years). The datum added by the reviser of the DH is a 22-year reign for Ahab. The synchronisms in both LXX and MT correspond to Ahab's reign length. However, we should opt for MT's

reading, because we have already determined that LXX's synchronism for the beginning of Ahab's reign (2nd of Jehoshaphat) is not the archetype. The Greek witness shows an attempt to harmonize the data. The synchronism for the end of the reign of Jehoshaphat was extended to the 24th year in order to give Ahab his needed 22 years, and the synchronism for the accession of Jehoshaphat, which would contradict the new synchronism for Ahab's accession, was omitted.

Table 4.6: Readings for Ahab, Jehoshaphat and Ahaziah

	Archetype	LXX²⁰⁹	MT
Royal Chronicles	Ahab accedes in 38 th of Asa Jehoshaphat accedes in 4 th of Ahab Ahaziah accedes in 17 th of Jehoshaphat	Ahab accedes in 2nd of Jehoshaphat [Jehoshaphat synchronism omitted] Ahaziah accedes in 24th of Jehoshaphat	Ahab accedes in 38 th of Asa Jehoshaphat accedes in 4 th of Ahab Ahaziah accedes in 17 th of Jehoshaphat
King List	Ahab reigns 22 years	Ahab reigns 22 years	Ahab reigns 22 years

As might be expected, this last adjustment created an additional problem for LXX. Ahab's son Joram is said to have begun to reign in the 18th year of Jehoshaphat, a synchronism that is impossible if Ahab died in Jehoshaphat's 24th year. So this synchronism had to be moved forward as well, and LXX put Joram's accession in the 2nd year of Jehoram of Judah (2 Kings 1:18a). Strangely enough, the datum that puts Jehoram of Judah's accession in the 5th year of Joram of Israel (2 Ki 8:16-17) was kept as is, even though it is quite impossible with the revised synchronisms. It no doubt was overlooked because of its distance from 2 Kings 1:18.

²⁰⁹ The accession of Ahab is the last datum we have for OG. The rest of LXX's readings are from L (Lucianic text).

Table 4.7: Readings for Ahaziah, Joram and Jehoram

	Archetype	LXX	MT
Royal Chronicles	Ahaziah accedes in 17 th of Jehoshaphat Joram accedes in 18 th of Jehoshaphat Jehoram accedes in 5 th of Joram	Ahaziah accedes in 24th of Jehoshaphat Joram accedes in 2nd of Jehoram Jehoram accedes in 5 th of Joram	Ahaziah accedes in 17 th of Jehoshaphat Joram accedes in 18 th of Jehoshaphat Jehoram accedes in 5 th of Joram

A further example of an instance where the insertion of the reign totals prompted an adjustment in the synchronisms is in the case of the reign of Jehoram of Judah. Both MT and LXX begin his reign in the 5th year of Joram of Israel (2 Kings 8:16). MT concludes his reign in Joram's 12th year, making his reign 7-8 years long, and LXX concludes his reign in Joram's 11th year, making his reign 6-7 years long (2 Kings 8:25). The reign length in LXX does not coincide with the reign total of 8 years provided by the Judahite king list. That of MT does. So again it would seem that in MT the synchronism was pushed forward from Joram's 11th year to his 12th year to accommodate the new datum. The formula at 2 Kings 9:29 in both MT and LXX retain the original synchronism in the 11th year of Joram. The contradiction between 2 Kings 9:29 and 2 Kings 8:25 seems to have gone unnoticed in MT, perhaps because it is uncustomary for a synchronism to be repeated and the datum in 9:29 is not in the typical location for synchronisms.

Table 4.8: Readings for Jehoram and Ahaziah

	Archetype	LXX	MT
Royal Chronicles	Jehoram accedes in 5 th of Joram Ahaziah accedes in 11 th of Joram	Jehoram accedes in 5 th of Joram Ahaziah accedes in 11 th of Joram	Jehoram accedes in 5 th of Joram Ahaziah accedes in 12th of Joram
King List	Jehoram reigns 8 years	Jehoram reigns 8 years ²¹⁰	Jehoram reigns 8 years

Despite the numerous alterations that were made, neither the Hebrew nor the Greek textual traditions satisfyingly harmonized the variant data so that all inconsistencies were eliminated. (This much we knew already.) In 1 Kings 14-16, the OG reading appears to retain the original synchronisms more consistently than MT, while MT retains the original reign lengths. However, in 1 Kings 16-2 Kings 3, where the OG is not extant, MT appears to be more reliable than the Lucianic texts when it comes to the synchronisms. In one final case, 2 Kings 8:25, the Lucianic texts seem to preserve a more original reading than MT in the synchronism for Ahaziah of Judah. From this point in the texts forward, however, both traditions agree in their figures. In regard to 2 Kings 21-25, this is not surprising, since the section contains no synchronisms (because Israel was destroyed), and therefore no data from the Judahite king list would contradict any existing chronological information. However, the fact that the Greek and Hebrew text traditions are at odds so frequently in 1 Kings 14-2 Kings 8 and suddenly agree in all respects in 2 Kings 9-20 should make us somewhat suspicious. To be sure, the reason for the agreement could be simply that the data for the reigns of the latter monarchs in the king lists and chronicles were already in harmony. A strong possibility exists, however, that the editors of MT continued to harmonize the figures they inherited (as they have

done consistently up to this point) and that the Lucianic texts have been adjusted to conform to MT in this section of the text.²¹¹ Neither of these two text traditions have been reliable up to this point, and we have no copy of OG for this portion of the text. There is a good chance that the original readings no longer exist in either tradition. Is there any chance of our recovering the earlier readings? Perhaps. The text does provide us with a couple of clues that enable reconstruction.

The existence of an anomalous datum, which appears to have escaped the editor's pen, suggests that changes were indeed made. There is reason to believe that an adjustment to a synchronism to accommodate a reign total occurred in 2 Kings 15:1. According to both MT and LXX, Azariah (Uzziah) acceded to the throne of Judah in the 27th year of Jeroboam. However, in a datum within a narrative about Azariah's father Amaziah, it is asserted that Amaziah lived 15 years (inclusive) after the death of King Joash of Israel, and therefore 15 years from the accession of Jeroboam, who was Joash's son (2 Kings 14:17). If this datum were true, then Azariah would have succeeded his father Amaziah in the 14th, 15th, or 16th year of Jeroboam, rather than the 27th (we are unable to narrow it down further). Two traditions are in conflict. Both cannot be correct. In one, Amaziah rules from the 2nd year of Joash until the 27th year of Jeroboam (a longer reign). In the other, Amaziah rules from the 2nd year of Joash until the 14th, 15th, or 16th year of Jeroboam (a shorter reign). The fact that the contradictory information exists in the same text suggests that there was an editorial alteration, but that one of the two data

²¹⁰ This reading is in the b manuscript only. Mss o and e₂ read "10 years."

²¹¹ It is generally held that portions of L were made to conform to the Hexaplaric text, which is well known for its conformity to MT. See Shenkel, *Chronology and Recensional Development in the Greek Text of Kings*, 8, 18-21, Emanuel Tov, *Textual Criticism of the Hebrew Bible*, 2nd ed. (Minneapolis: Augsburg Fortress, 2001), 148.

was overlooked. We should expect a change in a synchronism to have been made in the usual spot (the accession notice), and the synchronism implied by the statement at 2 Kings 14:17 is found in an obscure passage and thus more likely to have been passed over. It seems best to consider the datum placing Amaziah's death in the 14th, 15th, or 16th year of Jeroboam as more reflective of an original chronology than the one at 2 Kings 15:1. Josephus appears to have had a manuscript that preserved the older reading; he states that Azariah took the throne of Judah in the 14th year of Jeroboam.²¹² The patterns that have been displayed in the text traditions noted above suggest that the same sort of deliberate harmonization that occurred there occurred here. 2 Kings 15:1 originally read the 14th year of Jeroboam, but was changed to the 27th to extend the reign of Amaziah to make it total 29 years, in accordance with the reign total provided by Dtr². If that were the case, then the reign length of Amaziah indicated by the original synchronism would have been about 11-13 years shorter than the 29 years from the king list and would have equaled about 15-17 years.

Table 4.9: Readings for Amaziah and Azariah

	Archetype	LXX	MT
Royal Chronicles	Amaziah accedes in 2 nd of Joash Amaziah lives 15 years after death of Joash Azariah accedes in 14 th of Jeroboam	Amaziah accedes in 2 nd of Joash Amaziah lives 15 years after death of Joash Azariah accedes in 27th of Jeroboam	Amaziah accedes in 2 nd of Joash Amaziah lives 15 years after death of Joash Azariah accedes in 27th of Jeroboam
King List	Amaziah reigns 29 years	Amaziah reigns 29 years	Amaziah reigns 29 years

²¹² *Antiquities of the Jews*, 9:216, 227.

Another inference can be drawn from 2 Kings 14:17. If Amaziah lived 15 years after the death of Joash until Jeroboam's 14th year, then Joash would have died in Amaziah's 2nd year,²¹³ and his son Jeroboam would have succeeded him then. However, this is in contradiction with the datum provided by 2 Kings 14:23, which states that Jeroboam took the throne in the 15th year of Amaziah. It would appear that another alteration was made to accommodate the king list. The datum in 2 Kings 14:23 originally put Jeroboam's accession in Amaziah's 2nd year, making the length of Joash's reign 4-5 years long, but when it was noted that the king list gave Joash 16 years, about 11-12 years were added to the synchronism to accommodate the new figure.

There would have been a major repercussion to this last change that the editors simply could not have ignored, and we cannot either. By moving the synchronism for Jeroboam's accession from the 2nd year of Amaziah to the 15th of Amaziah, the reign of Jeroboam would have been shortened by 12-14 years. In order to restore his reign to its proper length, no fewer than five synchronisms, all set in the reign of Azariah of Judah, would have to have been pushed forward 12-14 years. These would be the accession years of Zechariah, Shallum, Menahem, Pekahiah, and Pekah. If this is true, then the current synchronisms for these Israelite kings are 12-14 years too late. Instead of their accessions taking place in the 38th, 39th, 39th, 50th, and 52nd years of Azariah, respectively, the original dates would have been about the 26th, 27th, 27th, 38th, and 40th years of Azariah respectively.²¹⁴ The chronicles (synchronisms) would have given Azariah a reign of about 40 years. The 12-year adjustment would have had the added benefit (or perhaps

²¹³ He could not have died in Amaziah's 1st year, because this would fall before Jeroboam's 1st year, and he could not have died in Amaziah's 3rd year, because this would not equal 15 (inclusive) years.

this was the primary motivation) of bringing the length of Azariah's reign into harmony with the king list (52 yrs) (consider that his successor Jotham acceded in the 2nd year of Pekah).

The anomalous datum in 2 Kings 15:30, which is probably not original, as argued below, nevertheless indicates there was another problem that later editors attempted to rectify. It states that Hoshea came to the throne of Israel in the 20th year of Jotham of Judah. This is in direct contradiction of 2 Kings 17:1, which states that Hoshea came to the throne in the 12th year of Ahaz. We might dismiss 2 Kings 15:30 out of hand, but its very existence should give us pause. Why was the datum invented? What contradiction was it trying to correct? The lengthening of Jotham's reign would have had the effect of lengthening also the reign of Pekah. This is likely to have been the intention. Since Jotham is stated as taking the throne in the 2nd year of Pekah (16:1), if Hoshea took the throne in the 20th year of Jotham, then Pekah's reign would come out to be 20-21 years. It would appear that this was an attempt to make the length of Pekah's reign conform to the reign length provided by the king list (20 yrs). 2 Kings 15:30 stands apart from MT's and LXX's other chronological data and may be set aside for the time being. Nevertheless, it does indicate that the reign of Pekah, as suggested by the original synchronisms, had been shorter than 20 years, and therefore that at least one of the synchronisms of 2 Kings 16:1 and 17:1, which taken together give Pekah a reign of 28 years, must be incorrect. Since multiple pieces of evidence affirm that Hoshea was a contemporary of the young King Hezekiah of Judah, we would expect that he would have been crowned somewhere near

²¹⁴ I assume a 12-year difference on the ground that the editors would have chosen the minimum amount necessary to correct the problem.

the end of the reign of Ahaz, and so the synchronism in 17:1 is more likely to be original than the one in 16:1. No doubt an editor, in an attempt to lengthen the reign of Jotham to the 16 years ascribed to him in the king list, advanced the accession of Ahaz to Pekah's 17th year. Unfortunately no existing manuscript of the DH, nor any other unnoticed reading in the DH, gives us a clue as to what the original reading was. Nevertheless, a datum in a Deuteronomistic section of Isaiah may be of assistance. It sets the reign of Ahaz 65 years (inclusive) before Ephraim is "shattered from being a people" (Isa 7:8). If we knew when this event took place, we might be able to sort this matter out. To do this, we have no choice but to look to extrabiblical evidence. According to Assyrian chronology, after his capture of Sidon in 677, the Assyrian king Esarhaddon deported the population of Samaria (cf. Ezra 4:2), and this appears to be what Isaiah is referring to. Counting back 64 years from 677 or 676 BCE (when this event occurred) brings us to 739 or 740 BCE. This should be sometime in Ahaz's reign. If Samaria fell in Hoshea's 9th year (2 Ki 18:9-10), and this was the year 720 (see below), then 739 or 740 would correspond to Pekah's 2nd or 3rd year. This is about as early as we can make Ahaz's accession, so we will tentatively assume the original reading assigned his accession to Pekah's 3rd year.

Table 4.10: Readings for Jotham, Ahaz and Hoshea

	Archetype	LXX	MT
Royal Chronicles	Jotham accedes in 2 nd of Pekah Ahaz accedes in [3 rd] of Pekah Hoshea accedes in 12 th of Ahaz	Jotham accedes in 2 nd of Pekah Ahaz accedes in 17th of Pekah Hoshea accedes in 12 th of Ahaz	Jotham accedes in 2 nd of Pekah Ahaz accedes in 17th of Pekah Hoshea accedes in 12 th of Ahaz
King List	Jotham reigns 16 years	Jotham reigns 16 years	Jotham reigns 16 years

To sum up, in the block of material from 2 Kings 9 to 20, the data preserved in 2 Kings 14:17 and 15:30 indicate that a total of 8 synchronisms may have been tampered with. Fortunately, the original readings can be more-or-less reconstructed from the textual evidence (with only the last having to appeal to extrabiblical sources). I can find no other evidence within the biblical text to suggest that any other alterations were made between 2 Kings 9 and 20.

d. Conclusions

Before proceeding, a review of the conclusions that have been reached so far may be worthwhile:

1) For the time of the kings, the original version of the Deuteronomistic History contained chronological data only from the Judahite and Israelite royal chronicles, which placed events in specific regnal years, but did not provide totals for the length of kings' reigns. Neither of the chronicles contained dates that indicated the month and day that an event occurred. Only years were recorded. Neither kingdom kept track of the regnal years of the other. However, they would take note of the accession of a new king in the other kingdom.

2) The total counts for kings' reigns were added to the DH during the exile and derive from king lists that were not directly connected with the royal chronicles.

3) The chronological notes in MT 1 Kings 16:10, 2 Kings 1:17, and 2 Kings 15:30 do not appear to derive from either the chronicles or the king lists and are probably later additions.

4) The biblical evidence suggests that Judah counted its kings' regnal years from the autumn in the later monarchic period, and this is likely a holdover from earlier times. Evidence for a civil calendar beginning in the autumn strengthens this conclusion.

5) There is sufficient evidence to indicate that Israel counted its kings' regnal years from a different time of year than Judah did, so they probably had a spring-based regnal calendar.

6) The Judahite king list assumes an accession-year system in Judah. The Judahite royal chronicle used by the Deuteronomistic Historian appears to agree, and this evidence suggests that the kingdom employed this system throughout its history.

7) The difference in year totals between the Israelite and Judahite king lists suggests that Israel employed the non-accession-year system in its early period.

8) In their chronicles, neither kingdom noted co-regencies of the other kingdom, so they either ignored them, or there were no co-regencies.

9) Discrepancies within the Deuteronomistic History between reign lengths and synchronisms were variously adjusted in both MT and OG.

B. Historical Reconstructions

Now that we know the chronological sources of the Deuteronomistic History and can approximate their data, we may examine in more detail the question of historical reliability. Such an exercise may assist in determining how far removed from the reality each of the sources is, and perhaps a little about their independent textual history. At this point, we will concern ourselves only with the chronology of the kings. It is very possible that both the chronicles and the king lists will present a chronology that is at variance

with the historical reality, or at least with the data that comes from Assyria and Babylon, since chronological data from earlier times may have been inadequately preserved (a statement we could make about the foreign material as well).

The records of kingdoms neighboring Israel and Judah occasionally make reference to interactions with those two countries and sometimes mention kings by name. Rarely, however, is an exact date associated with one of these references. Surprisingly, in the entire history of the Israelite and Judahite kingdoms, only two dated events in extrabiblical sources may be matched with dated events in biblical sources:

1) *Year 21 of Nabopolassar of Babylon = Year 4 of Jehoiakim of Judah.* Prince Nebuchadnezzar, in the 21st year of his father, defeated the Egyptians in the Battle of Carchemish in May/June of 605 BCE (BM 21946). Jeremiah 46:2 places this battle in the fourth year of Jehoiakim. Keep in mind that the Mesopotamian regnal year began in the spring, and the Judahite regnal year in the autumn.

2) *Year 17 of Nabopolassar of Babylon = year of the death of Josiah.* The Babylonian Chronicle (BM 21901) informs us that, in the year following Nabopolassar's 16th year, "a large army of Egypt" allied with the king of Assyria invaded the Levant with the intention of taking Haran from the Babylonians (summer of 609 BCE). This is almost certain to be the force that King Josiah engaged in battle and by whom he was slain (2 Kings 24:29).²¹⁵

A possible third synchronism, equating Year 4 of Sennacherib of Assyria with Year 14 of Hezekiah of Judah, cannot be maintained (see Appendix B).

²¹⁵ For a discussion of these two synchronisms, see D.N. Freedman, "The Babylonian Chronicle," *Biblical Archaeologist* 19 (1956): 50-60.

Three further synchronisms are provided by Jeremiah's scribe and by the exilic reviser of the Deuteronomistic History in the final chapter of Kings, and are probably reliable:

1) *Year 19 of Nebuchadnezzar of Babylon = Year 11 of Zedekiah of Judah and the destruction of Jerusalem* (2 Kings 25:2, 8).

2) *Year 18 of Nebuchadnezzar of Babylon = Year 10 of Zedekiah of Judah* (Jer 32:1).

3) *Year 8 of Nebuchadnezzar of Babylon = the accession of Zedekiah of Judah.*

The Babylonian Chronicle (BM 21946, rev., ll. 11-13) provides us with an exact date for Nebuchadnezzar's deposal of Jehoiachin, which corresponds to March 16, 597 BCE in the Julian calendar (the tail end of Nebuchadnezzar's 7th year). The deposal of Jehoiachin by Nebuchadnezzar is mentioned also in the DH (2 Kings 24:10-11), but a date is not given. Nevertheless, it also tells us that Jehoiachin (who had only reigned three months) was taken to Babylon the following year (24:12), probably a month or two after his deposal. We should keep in mind that Judah is not likely to have accepted the deposal of Jehoiachin (at least not officially) while he was still present in Jerusalem, despite what Nebuchadnezzar may have declared. The fact that the Judahites dated the end of the reign of Jehoiachin and the accession of Zedekiah early in Nebuchadnezzar's 8th year confirms this. For the Judahites, Jehoiachin's reign would have ended when, and only when, he had left the country.

(Note: Considering we know for certain that Jehoiakim's accession year ended in the autumn of 609 and that Jehoiachin ended his 3-month reign sometime in or after March 597, there is no way around the fact that Jehoiachin took the throne in Jehoiakim's

12th year. Jehoiakim's reign length in the Judahite king list [11 years] is therefore one year short of the reality.)

There are three other synchronisms we can reconstruct with a reasonable amount of certainty:

1) *Year 10 of Sargon of Assyria = Year 14 of Hezekiah of Judah.* The year of an Assyrian punitive campaign against the Philistines in 712 BCE also involved the Judahites (Nineveh Prism A, Fragment D). For a full discussion of this synchronism, see Appendix B.

2) *Year 2 of Sargon of Assyria = Year 6 of Hezekiah of Judah and Year 9 of Hoshea of Israel.* In many of his inscriptions, Sargon claims to have fought against Samaria in his first two years of kingship and conquered it completely by his second year, 720 BCE (Lie, 4-7, II.3, ll. 10-17). The DH provides the Judahite and Israelite synchronisms (2 Kings 18:10-11).

3) *Year 5 of Shalmaneser V of Assyria = Year 4 of Hezekiah of Judah and Year 7 of Hoshea of Israel.* The Babylonian Chronicle claims that Shalmaneser ravaged Samaria (most likely referring to the country rather than the city) sometime during his short reign (I, ll. 27-30). The DH confirms this (2 Kings 18:9). Since Sargon was king the following year, the year of Shalmaneser's campaign against Israel must have been his fifth and last (722 BCE).

Finally, there are several historical events recorded in extrabiblical sources that pertain to kings of Israel or Judah and which, although they cannot be placed in a precise year, assist us generally in ascertaining approximate synchronisms.

1) *early in the reign of Ashurbanipal of Assyria = sometime in the reign of Manasseh of Judah.* The Prism C inscription of Ashurbanipal (I, l. 25) includes Manasseh in a list of kings bearing tribute from the coastlands. These vassals are said to have assisted Ashurbanipal in his invasion of Egypt (664-663 BCE).

2) *Year 4 or 5 of Esarhaddon of Assyria = sometime in the reign of Manasseh of Judah.* An inscription of Esarhaddon refers to Manasseh giving tribute to the Assyrian king (Nineveh prism A, V, l. 55). The precise year of the event is unclear, but Manasseh is listed among 22 “seacoast and sea kings” who gave tribute sometime after the fall of Sidon in 677 BCE, so this is likely to have occurred either in Esarhaddon’s 4th or 5th year (677 or 676 BCE).

3) *Year 4 of Sennacherib of Assyria = sometime in the reign of Hezekiah of Judah.* While the synchronism of Sennacherib’s 4th year with Hezekiah’s 14th can no longer be maintained (see Appendix B), it is certain that Sennacherib did attack Hezekiah in 701 BCE, and this is likely to have occurred sometime after Hezekiah’s 14th year.

4) *sometime in the reign of Marduk-apla-iddina II of Babylon = Year 14 of Hezekiah.* The DH refers to a visit of the Babylonian king (Merodach-baladan) to Hezekiah’s court (2 Kings 20:12-19). The trip is prompted by Hezekiah’s illness, which is dated to his 14th year (20:6; cf. 18:13 with 20:1). Marduk-apla-iddina reigned from 722 to 710 BCE.

5) *soon after the death of Tiglath-pileser III of Assyria = accession of Hezekiah.* A prophecy of Isaiah (14:28-32) places the death of Ahaz shortly after “the staff of the one striking [Philistia]” was “broken.” This no doubt refers to Tiglath-pileser, who died in 727 BCE. The death of Ahaz probably occurred in that year or the year after.

6) *Year 15 or 17 of Tiglath-pileser III of Assyria = coronation of Hoshea of Israel.* Tiglath-pileser claims to have replaced Peqah with Hoshea on the throne of Israel (Summary Inscription 4, ll. 15-19; Summary Inscription 9, ll.10-11). The latter text puts Hoshea's accession during Tiglath-pileser's campaign against Sarrabani in Babylonia. Apparently, Hoshea or one of his messengers traveled quite a distance to secure the kingship. Tiglath-pileser's presence in Sarrabani could be associated with the campaign against southern Babylonia that included the siege of Shapiya in 731 BCE (according to the Eponym Chronicle) or the next campaign against southern Babylonia in 729 (according to the Eponym Chronicle). The records are too fragmentary to pinpoint the year exactly.

7) *Year 11, 12 or 13 of Tiglath-pileser III of Assyria = sometime in the reign of Ahaz of Judah.* Ahaz is mentioned in a list of Levantine tribute-bearing kings (Summary Inscription 7, rev. l. 11). The date of this event is disputed, but it probably occurred somewhere between 735 and 733 BCE.

8) *64 years before Esarhaddon of Assyria deported the population of Phoenicia-Samaria = sometime in the reign of Ahaz.* After his capture of Sidon in 677, Esarhaddon deported the population of the area (cf. Ezra 4:2). The Deuteronomic narrative in Isaiah 7 sets the reign of Ahaz 65 years (inclusive) before this event, when Isaiah prophesies, "In yet 65 years, Ephraim will be shattered from being a people" (Isa 7:8). Counting 64 years back from 677 or 676 brings us to 739 or 740 BCE. This should be sometime in Ahaz's reign.

9) *sometime in the reign of Tiglath-pileser III of Assyria = sometime in the reign of Menahem of Israel.* The date of Menahem's payment of tribute to Assyria has been

hotly debated. Some have argued that the Assyrian records (Iran Stele, IIIA, l. 5; Ann. 13*:10; Ann. 27:2) indicate two different payments. Because of the fragmentary nature of the Assyrian materials, the matter is far from settled, and cases have been made for 743, 740, and 738 BCE.²¹⁶

10) *sometime in the reign of Adad-nirari III of Assyria = sometime in the reign of Joash of Israel.* Joash is listed among tribute-bearers to Adad-nirari III (Tell al-Rimah inscription, l. 8). The exact year is unknown. Adad-nirari reigned from 811 to 783 BCE.

11) *Year 18 of Shalmaneser III of Assyria = sometime in the reign of Jehu of Israel.* The bearing of tribute by Jehu is attested in several inscriptions of Shalmaneser (Black Obelisk, relief B; IM 55644; annals of year 20 of the city of Ashur: III, l. 45 – IV, l. 15; Kurba'il Statue, 29-30) and can be confidently dated to 841 BCE.

12) *Year 6 of Shalmaneser III of Assyria = sometime in the reign of Ahab of Israel.* Ahab is mentioned in the somewhat unreliable Kurkh Monolith inscription (II: ll. 91ff.) in association with the Battle of Qarqar, which took place in 853 BCE.

13) *Sometime in the reign of Shoshenq I of Egypt = Year 5 of Rehoboam of Judah.* Egyptian chronologists, using a combination of archaeological evidence, monumental inscriptions, astronomy, and Egyptian king lists, place Shoshenq's reign c. 945-925 B.C.E.²¹⁷

²¹⁶ See discussions in Thiele, *MNHK*, 139-62, Hayim Tadmor, *The Inscriptions of Tiglath-pileser III, King of Assyria* (Jerusalem: Israel Academy of Sciences and Humanities, 1994), 274-75.

²¹⁷ For a summary of the evidence, see Kenneth A. Kitchen, "The Historical Chronology of Ancient Egypt, A Current Assessment," in *The Synchronisation of Civilisations in the Eastern Mediterranean in the Second Millennium B.C.*, ed. Manfred Bietak (Wien: Verlag der Österreichischen Akademie der Wissenschaften, 2000): 39-52, A. J. Shortland, "Shishak, King of Egypt: The Challenges of Egyptian

Let us first compare the eight precise synchronisms and the thirteen approximate synchronisms with the Judahite king list that fell into the hands of the reviser of the DH. On its own it provides a chronology of the monarchy of Judah from Rehoboam to Zedekiah. Working back from an absolute date of 586 for the end of the kingdom,²¹⁸ we arrive at the following dates B.C.E. for the kings of the divided kingdom:

Rehoboam (973-956)
 Abijam (956-953)
 Asa (953-912)
 Jehoshaphat (912-887)
 Jehoram (887-879)
 Ahaziah (879-878)
 Jehoash (878-838)
 Amaziah (838-809)
 Azariah (809-757)
 Jotham (757-741)
 Ahaz (741-725)
 Hezekiah (725-696)
 Manasseh (696-641)
 Amon (641-639)
 Josiah (639-608)
 Jehoahaz (608)
 Jehoiakim (608-597)
 Jehoiachin (597)
 Zedekiah (597-586)

It is important to note that the scheme above assumes that the years attributed to each king in the king list represent actual years. In a post-dating system (in which the accession year of a king is not counted), the number of regnal years for each king is equal to the number of actual years he reigned. It could be objected that the ancient Israelite who compiled the data counted the totals inclusively. Nevertheless, as was demonstrated above, each block of time would be added exclusively, so an inclusive count would only

Calendrical Chronology," in *The Bible and Radiocarbon Dating*, ed. Thomas E. Levy and Thomas Higham (London: Equinox, 2005): 43-54.

affect the year of the accession of Rehoboam (making it 972). The rest of the years would remain the same.

Considering that the core of the list was composed in the reign of Amon and was supplemented sometime between the end of the monarchy and the revision of the DH during the exile, there is the possibility that some of the figures, particularly the earlier ones, are inaccurate. Extrabiblical synchronisms fit the king list's chronology in many instances in the later reigns. For example, the conquest of Jerusalem by Nebuchadnezzar of Babylon, in year 7 of his reign (597) and the installation of Zedekiah a few months later matches the dates here. Also, the Assyrian king Sennacherib mentions King Hezekiah and an invasion of Judah in the fourth year of his reign (701), which falls within the years attributed to Hezekiah here. In Hezekiah's reign, the king list is close but appears to have lost a year somewhere. It is prior to Ahaz that the dates seem to fall further and further short of what they should be. The reign of Shoshenq I (c. 945-925) covers a period of years falling well after Rehoboam's reign here. The dates for the reign of Rehoboam are thus far too early.

²¹⁸ For the date 586, see Chapter One, Section D.2.d. For the evidence that Zedekiah took the throne in Nebuchadnezzar's 8th year, see the discussion on extrabiblical synchronisms directly above.

Table 4.11: Comparison of Extrabiblical Dates with Judahite King List Dates

Extrabiblical Synchronisms	King List Dates
Sometime during the reign of Shoshenq I of Egypt (c. 945-925) = Year 5 of Rehoboam. No match	→ Rehoboam (973-956) Abijam (956-953) Asa (953-912) Jehoshaphat (912-887) Jehoram (887-879) Ahaziah (879-878) Jehoash (878-838) Amaziah (838-809) Azariah (809-757) Jotham (757-741)
64 years before Esarhaddon of Assyria deports the population of Phoenicia-Samaria (740 or 739) = sometime in the reign of Ahaz. Match	→ Ahaz (741-725)
Year 11, 12 or 13 of Tiglath-pileser III of Assyria (735, 734 or 733) = sometime in the reign of Ahaz. Match	→
Soon after the death of Tiglath-pileser III of Assyria (727 or 726) = accession of Hezekiah. No match	→ Hezekiah (725-696)
Year 5 of Shalmaneser V of Assyria (722) = Year 4 of Hezekiah. No match	→
Year 2 of Sargon of Assyria (720) = Year 6 of Hezekiah. No match	→
10 of Sargon of Assyria (712) = Year 14 of Hezekiah of Judah. No match	→
sometime in the reign of Marduk-apla-iddina II of Babylon (722-710) = Year 14 of Hezekiah. Match	→
Year 4 of Sennacherib of Assyria (701) = sometime in the reign of Hezekiah of Judah. Match	→
Year 4 or 5 of Esarhaddon of Assyria (677 or 676) = sometime in the reign of Manasseh of Judah. Match	→
early in the reign of Ashurbanipal of Assyria (664 or 663) = sometime in the reign of Manasseh of Judah. Match	→ Manasseh (696-641)
	→ Amon (641-639) Josiah (639-608) Jehoahaz (608)
Year 8 of Nebuchadnezzar of Babylon (597) = the accession of Zedekiah of Judah. Match	→ Jehoiakim (608-597) Jehoiachin (597) Zedekiah (597-586)

The king list, therefore, has given us reason not to accept its earlier dates at face value. We do not know what sources the compiler of the king list used, although the information seems ultimately to have its origin in primary documentation. Whatever the historical value of the Judahite king list used by the reviser of the History, we must accept that these are its dates, and that it represents the chronology of the person(s) who composed it, whether they had access to reliable information or not. Even if it drew from a common tradition with the other chronological sources used in the DH, it must be understood independently from those sources, and from the historical reality as well.

When we add up the lengths of the reigns of the kings of Israel (assuming the figures are antedated years), we arrive at a date circa 946 B.C.E. for the division of the kingdom. This date falls short of the Judahite total by some 17 years.

Jeroboam (946-925)
 Nadab (925-924)
 Baasha (924-901)
 Elah (901-900)
 Zimri (900)
 Omri (900-889)
 Ahab (889-868)
 Ahaziah (868-867)
 Jehoram (867-856)
 Jehu (856-829)
 Jehoahaz (829-813)
 Joash (813-798)
 Jeroboam (798-758)
 Zechariah (758)
 Shallum (757)
 Menahem (757-748)
 Pekahiah (748-747)
 Pekah (747-728)
 Hoshea (728-720)

The two lists are incompatible with each other as they stand (further corroborating our conclusion that they come from two different sources).

Because Judah used a postdating system, and Israel used an antedating system, we should expect that the Judahite king list provides us with actual years, and that the Israelite king list provides us with antedated years. This conclusion is justified by our observation of the cases of two kings whose reign lengths are stated explicitly by both a king list and a chronicle. For Israel, we have the example of Hoshea, about whom it is said that he reigned 9 years (2 Kings 17:1) and about whom it is also said that his reign ended in his 9th year (2 Kings 18:10). The first datum comes from the Israelite king list, the second from the Israelite chronicle. We know that the chronicle uses antedating. Thus the 9th year = 8 actual years. Since the king list gives 9 years, it must also be antedated. For Judah, we have the example of Zedekiah, about whom it is said that he reigned 11 years (2 Kings 24:18) and about whom it is also said that his reign ended in his 11th year (2 Kings 25:8). The first datum comes from the Judahite king list and the second from the Judahite chronicle. We know that the chronicle uses postdating. Thus the 11th year = 11 actual years. Since the king list gives 11 years, it is stating actual years.

The numbers from the Israelite king list, when compared with the extrabiblical synchronisms listed above, clearly are defective. The reigns of the kings do not coincide with the historical reality very well at all.

Table 4.12: Comparison of Extrabiblical Dates with Israelite King List Dates

Extrabiblical Synchronisms	King List Dates
	Jeroboam (946-925) Nadab (925-924) Baasha (924-901) Elah (901-900) Zimri (900) Omri (900-889)
Year 6 of Shalmaneser III of Assyria (853) = sometime in the reign of Ahab of Israel. No match	→ Ahab (889-868)
Year 18 of Shalmaneser III of Assyria (841) = sometime in the reign of Jehu of Israel. Match	→ Ahaziah (868-867)
Sometime in the reign of Adad-nirari III of Assyria (811-783) = sometime in the reign of Joash of Israel. Match	→ Jehoram (867-856)
Sometime in the reign of Tiglath-pileser III of Assyria (743, 740, or 738) = sometime in the reign of Menahem of Israel. No match	→ Jehu (856-829)
Year 15 or 17 of Tiglath-pileser III of Assyria (731 or 729) = coronation of Hoshea of Israel. No match	→ Jehoahaz (829-813)
	→ Joash (813-798)
	→ Jeroboam (798-758)
	→ Zechariah (758)
	→ Shallum (757)
	→ Menahem (757-748)
	→ Pekahiah (748-747)
	→ Pekah (747-728)
	→ Hoshea (728-720)

There is nothing extraordinary about the two extrabiblical synchronisms that are in harmony with the king list. Both cover very broad ground. It may be that only a small number of reign lengths are incorrect and are throwing the rest off, but we cannot put great trust in the figures. Unlike the Davidic dynasty in Judah in which all kings were from a single family, the northern kings often succeeded by usurpation. The constant turnover of government may account for the northern king list's greater inaccuracy.

It is clear, then, that we must get the second opinion offered by the chronicles, which, though incomplete, may nevertheless provide valuable information.

Unfortunately, there is also the chance that, for some kings, neither the figure in the king lists nor the one in the chronicles is historically accurate. In cases where the extrabiblical data suggest this, we may have to make some educated guesses about the historical

reality. In cases where there is a discrepancy between the king lists and the royal chronicles, and there is no extrabiblical evidence to suggest one or the other or either are correct, we will tentatively take the testimony of the chronicles as the most reliable.

Below is a list of the 24 events that are dated by a synchronism with the regnal year of a Judahite monarch, and which therefore may be understood as coming from the Judahite royal chronicle used as a source by the Deuteronomistic Historian:

Dates from the Judahite Royal Chronicle

- Rehoboam Year 5 – Shishak the king of Egypt came up against Jerusalem (1 Kings 14:25)
- Asa Year 2 – Nadab the son of Jeroboam became king over Israel (1 Kings 15:25)
- Asa Year 3 – Baasha the son of Ahijah became king over Israel in Tirzah (1 Kings 15:33)
- Asa Year 20 – Elah the son of Baasha became king over Israel in Tirzah (1 Kings 16:8)²¹⁹
- Asa Year [25] – Zimri became king over Israel in Tirzah (1 Kings 16:15)²²⁰
- Asa Year 31 – Omri became king over Israel (1 Kings 16:23)
- Asa Year 38 – Ahab the son of Omri became king over Israel in Samaria (1 Kings 16:29)²²¹
- Jehoshaphat Year 17 – Ahaziah the son of Ahab became king over Israel in Samaria (1 Kings 22:52)²²²
- Jehoshaphat Year 18 – Joram the son of Ahab became king over Israel in Samaria (2 Kings 3:1)²²³
- Jehoash Year 23 – Repairs made to the Temple (2 Kings 12:7); Jehoahaz the son of Jehu became king over Israel in Samaria (2 Kings 13:1)
- Jehoash Year 37 – Joash the son of Jehoahaz became king over Israel in Samaria (2 Kings 13:10)
- Amaziah Year [2] – Jeroboam the son of Joash became king over Israel in Samaria (2 Kings 14:23)²²⁴

²¹⁹ MT has this as Asa Year 26.

²²⁰ MT has this as Asa Year 27; L has this as Asa Year 22. Dtr¹ puts this event 6 years before Asa Year 31 (1 Kings 16:23).

²²¹ OG has this as Jehoshaphat Year 2.

²²² L has this as Jehoshaphat Year 24.

²²³ L has this as Jehoram Year 2.

²²⁴ The readings of MT and LXX are rejected in favor of the datum in 2 Kings 14:17, which states that Amaziah died 15 years after Joash's death and therefore 15 years after the accession of Jeroboam. A reign length of 16 or 17 years is suggested by the change that was made in 2 Kings 15:1, an addition of 11-12 years from the original number.

- Azariah Year [25] – Zechariah the son of Jeroboam became king over Israel for 6 months in Samaria (2 Kings 15:8)²²⁵
- Azariah Year [26] – Shallum the son of Jabesh became king over Israel for 1 month in Samaria (2 Kings 15:13); Menahem the son of Gadi became king over Israel in Samaria (2 Kings 15:17)
- Azariah Year [37] – Pekahiah the son of Menahem became king over Israel in Samaria (2 Kings 15:23)
- Azariah Year [39] – Pekah the son of Remaliah became king over Israel in Samaria (2 Kings 15:27)
- Ahaz Year 12 – Hoshea the son of Elah became king over Israel in Samaria (2 Kings 17:1)
- Hezekiah Year 4 – Shalmaneser the king of Assyria came up against Samaria and laid siege to it (2 Kings 18:9)
- Hezekiah Year 6 – Samaria was captured (2 Kings 18:10)
- Hezekiah Year 14 – Sennacherib the king of Assyria came up against all the fortified cities of Judah and laid siege to them (2 Kings 18:13)
- Josiah Year 18 – The king begins his religious reforms (2 Kings 22:3); Passover celebrated (2 Kings 23:23)

It is not certain whether the final date was derived from the chronicle or not, as the event recorded is understood to have occurred in the lifetime of the Historian.

Below is a list of the 13 events that are dated by a synchronism with the regnal year of an Israelite monarch, and which therefore may be understood as coming from the Israelite royal chronicle used as a source by the Deuteronomistic Historian:

Dates from the Israelite Royal Chronicle

- Jeroboam Year 18 – Abijam became king over Judah (1 Kings 15:1)
- Jeroboam Year 24 – Asa became king of Judah (1 Kings 15:9)²²⁶
- Ahab Year 4 – Jehoshaphat the son of Asa became king over Judah (1 Kings 22:41)²²⁷
- Joram Year 5 – Jehoram the son of Jehoshaphat became king alongside Jehoshaphat (2 Kings 8:16)
- Joram Year 11 – Ahaziah the son of Jehoram the king of Judah became king (2 Kings 8:25; 9:29)²²⁸

²²⁵ The restoration of Jeroboam's original accession date (see previous note) requires an equal restoration of the five dates occurring in Azariah's reign, beginning with Zechariah. See above.

²²⁶ MT has this as Jeroboam Year 20.

²²⁷ OG has this as Omri Year 11.

²²⁸ MT has this as Joram Year 12 at 2 Kings 8:25.

Jehu Year 7 – Jehoash became king (2 Kings 12:2)

Joash Year 2 – Amaziah the son of Jehoash the king of Judah became king (2 Kings 14:1)

Jeroboam Year [14] – Azariah the son of Amaziah the king of Judah became king (2 Kings 15:1)²²⁹

Pekah Year 2 – Jotham the son of Uzziah the king of Judah became king (2 Kings 15:32)

Pekah Year [3] – Ahaz the son of Jotham the king of Judah became king (2 Kings 16:1)²³⁰

Hoshea Year 3 – Hezekiah the son of Ahaz the king of Judah became king (2 Kings 18:1)

Hoshea Year 7 – Shalmaneser the king of Assyria came up against Samaria and laid siege to it (2 Kings 18:9)

Hoshea Year 9 – Samaria was captured (2 Kings 18:10)

The table below reconstructs a tentative chronology based on the synchronisms alone. All reign lengths should be within one or two years of the actual reign lengths assumed by the chronicles. We can do no better than that, because the regnal years of the two kingdoms overlapped. In cases where I had to choose between agreeing with a reign length in a king list or not, I chose to agree whenever it was possible. In many cases it was not.

²²⁹ The readings of MT and LXX are rejected in favor of the datum in 2 Kings 14:17, which states that Amaziah died 15 years after Joash's death and therefore 15 years after the accession of Jeroboam.

²³⁰ The existence of the anomalous datum in 2 Kings 15:30 suggests that Pekah's reign has been artificially lengthened and therefore that the synchronism of 2 Kings 16:1 is incorrect. See above.

**Table 4.13: Chronology of the Hebrew Kings
Based Upon the Synchronisms**

		Judahite Record		Israelite Record		
		Accession-year system in use		Nonaccession-year system in use		
		Autumn Years	Years BCE	Spring Years		
			935			
		REHOBOAM Ac	934			
		1	933	JEROBOAM 1		
		2	932	2		
		3	931	3		
		4	930	4		
	Shishak attacks 5th of Rehoboam 1 Ki 14:25	5	929	5		
		6	928	6		
		7	927	7		
		8	926	8		
		9	925	9		
				10		

Table 4.13 continued
 Judahite Record Years BCE Israelite Record

	10	924		
	11	923	11	
	12	922	12	
	13	921	13	
	14	920	14	
	15	919	15	
	16	918	16	
	17 ABIJAM Ac	917	17	
	1	916	18	Abijam 18th of Jeroboam 1 Ki 15:1
	2	915	19	
	3	914	20	
	4	913	21	
	5	912	22	
	6 ASA Ac	911	23	Asa 24th of Jeroboam
			24	1 Ki 15:9

Table 4.13 continued
 Judahite Record Years BCE Israelite Record

	1	910		
Nadab			25	
2nd of Asa	2	909	NADAB	
1 Ki 15:25			1	
Baasha			2	
3rd of Asa	3	908	BAASHA	
1 Ki 15:33			1	
	4	907	2	
	5	906	3	
	6	905	4	
	7	904	5	
	8	903	6	
	9	902	7	
	10	901	8	
	11	900	9	
	12	899	10	
	13	898	11	
	14	897	12	
			13	

Table 4.13 continued
 Judahite Record Years BCE Israelite Record

	15	896		
	16	895	14	
	17	894	15	
	18	893	16	
	19	892	17	
Elah 20th of Asa 1 Ki 16:8	20	891	18 ELAH 1	
	21	890	2	
	22	889	3	
	23	888	4	
	24	887	5	
Zimri & Omri [25th] of Asa 1 Ki 16:10, 15, 16	25	886	6	
	26	885	7 ZIMRI OMRI 1	TIBNI 1
	27	884	2	2
	28	883	3	3
			4	4

Table 4.13 continued

Judahite Record Years BCE Israelite Record

	29	882			
	30	881	5	5	
Omri 31st of Asa 1 Ki 16:23	31	880	6	6	Omri 6 yrs in Tirzah 1 Ki 16:23
	32	879	7		
	33	878	8		
	34	877	9		
	35	876	10		
	36	875	11		
	37	874	12		
Ahab 38th of Asa 1 Ki 16:29	38	873	13 AHAB 1		
	39	872	2		
	40	871	3		
	41 JEHOSHAPHAT Ac	870	4		Jehoshaphat 4th of Ahab 1 Ki 22:41
	1	869	5		
			6		

Table 4.13 continued
 Judahite Record Years BCE Israelite Record

	2	868		
	3	867	7	
	4	866	8	
	5	865	9	
	6	864	10	
	7	863	11	
	8	862	12	
	9	861	13	
	10	860	14	
	11	859	15	
	12	858	16	
	13	857	17	
	14	856	18	
	15	855	19	
			20	

Table 4.13 continued

	Judahite Record	Years BCE	Israelite Record	
Ahaziah	16	854		
17th of Jehoshaphat	17	853	21	
1 Ki 22:51			22	
Joram	18	852	AHAZIAH 1	
18th of Jehoshaphat	19	851	2	
2 Ki 3:1			JORAM 1	
	20	850	2	
	21	849	3	
	22	848	4	
	JEHORAM Ac			
	1	847	5	Jehoram 5th of Joram 2 Ki 8:16
	2	846	6	
	3	845	7	
	4	844	8	
	5	843	9	
	7	842	10	
	AHAZIAH Ac			Ahaziah 11th year of Joram 2 Ki 8:25
ATHALIAH 1	1	841	11	
			12	
			JEHU	

Table 4.13 continued

	Judahite Record	Years BCE	Israelite Record	
	2	840	1	
	3	839	2	
Athaliah 6 yrs 2 Ki 11:1-3	4	838	3	
	5	837	4	
	6	836	5	
	JEHOASH 1	835	6	Jehoash 7th of Jehu 2 Ki 12:2
	2	834	7	
	3	833	8	
	4	832	9	
	5	831	10	
	6	830	11	
	7	829	12	
	8	828	13	
	9	827	14	
			15	

Table 4.13 continued
 Judahite Record Years BCE Israelite Record

	10	826		
	11	825	16	
	12	824	17	
	13	823	18	
	14	822	19	
	15	821	20	
	16	820	21	
	17	819	22	
	18	818	23	
	19	817	24	
	20	816	25	
	21	815	26	
	22	814	27	
	23	813	28 JEHOAHAZ	
Jehoahaz 23rd of Jehoash 2 Ki 13:1			1	
			2	

Table 4.13 continued

Judahite Record Years BCE Israelite Record

	24	812		
	25	811	3	
	26	810	4	
	27	809	5	
	28	808	6	
	29	807	7	
	30	806	8	
	31	805	9	
	32	804	10	
	33	803	11	
	34	802	12	
	35	801	13	
	36	800	14	
	37	799	15 JOASH	
Joash 37th of Jehoash 2 Ki 13:10			1	Amaziah 2nd of Joash 2 Ki 14:1
	38		2	

Table 4.13 continued
 Judahite Record Years BCE Israelite Record

	AMAZIAH	798			
	Ac				
	1	797	3		
	2	796	4		
Jeroboam [3rd] of Amaziah 2 Ki 14:17	3	795	5 JEROBOAM		
	4	794	1		
	5	793	2		
	6	792	3		
	7	791	4		
	8	790	5		
	9	789	6		
	10	788	7		
	11	787	8		
	12	786	9		
	13	785	10		
				11	
				12	

Table 4.13 continued
 Judahite Record Years BCE Israelite Record

	14	784		
	15	783	13	
	16 AZARIAH Ac	782	14	
	1	781	15	
	2	780	16	
	3	779	17	
	4	778	18	
	5	777	19	
	6	776	20	
	7	775	21	
	8	774	22	
	9	773	23	
	10	772	24	
	11	771	25	
			26	

Azariah
 14th of
 Jeroboam
 2 Ki 15:1

Table 4.13 continued
 Judahite Record Years BCE Israelite Record

	12	770		
	13	769	27	
	14	768	28	
	15	767	29	
	16	766	30	
	17	765	31	
	18	764	32	
	19	763	33	
	20	762	34	
	21	761	35	
	22	760	36	
	23	759	37	
	24	758	38	
	25	757	39	
			40	

Table 4.13 continued
 Judahite Record Years BCE Israelite Record

Zechariah [26th] of Azariah 2 Ki 15:8 Menahem [27th] of Azariah 2 Ki 15:17		26	756		
				41	
				ZECHARIAH	
		27	755	1	
				SHALLUM	
				MENAHHEM	
		28	754	1	
				2	
		29	753		
				3	
		30	752		
				4	
		31	751		
			5		
	32	750			
			6		
	33	749			
			7		
	34	748			
			8		
	35	747			
			9		
	36	746			
			10		
	37	745			
			11		
Pekahiah [38th] of Azariah 2 Ki 15:23		38	744	12	
				PEKAHIAH	
		39	743	1	
			2		
	40		PEKAH		
				Jotham 2nd of Pekah 2 Ki 15:32	

Table 4.13 continued

	Judahite Record	Years BCE	Israelite Record	
Pekah [40th] of Azariah 2 Ki 15:27	JOTHAM Ac	742	1	
	1	741	2	
	2 AHAZ Ac	740	3	Ahaz [3rd?] of Pekah 2 Ki 16:1
	1	739	4	
	2	738	5	
	3	737	6	
	4	736	7	
	5	735	8	
	6	734	9	
	7	733	10	
	8	732	11	
	9	731	12	
	10	730	13	
	11	729	14	
			15 HOSHEA	

Table 4.13 continued

	Judahite Record	Years BCE	Israelite Record	
Hoshea	12	728	1	
12th of Ahaz				
2 Ki 17:1	13	727	2	
	14		3	Hezekiah
	HEZEKIAH	726		3rd of Hoshea
	Ac		4	2 Ki 18:1
	1	725		
	2	724	5	
	3	723	6	
Shalmaneser				Shalmaneser
attacks				attacks
Samaria			7	Samaria
4th of	4	722		7th of Hoshea
Hezekiah				2 Ki 18:9
2 Ki 18:9	5	721	8	
Samaria			9	Samaria
conquered				conquered
6th of	6	720		9th of Hoshea
Hezekiah				2 Ki 18:10
2 Ki 18:10				

To summarize the reconstruction of the table, we arrive at the following years for each of the kings:

Judah

Rehoboam (934-917)
 Abijam (917-911)
 Asa (911-870)
 Jehoshaphat (870-848)
 Jehoram (848-842)
 Ahaziah (842-841)²³¹
 Jehoash (841-798)
 Amaziah (798-782)
 Azariah (782-742)
 Jotham (742-740)
 Ahaz (740-726)
 Hezekiah (726-)

Israel

Jeroboam (934-910)
 Nadab (910-909)
 Baasha (909-892)
 Elah (892-886)
 Zimri (886)
 Omri (886-874)
 Ahab (874-853)
 Ahaziah (853-852)
 Jehoram (852-841)
 Jehu (841-814)
 Jehoahaz (814-800)
 Joash (800-796)
 Jeroboam (796-756)
 Zechariah (756)
 Shallum (755)
 Menahem (755-743)
 Pekahiah (743-742)
 Pekah (742-729)
 Hoshea (729-720)

A comparison of these years with the extrabiblical synchronisms above reveals that there is nothing clearly defective in the chronological material of the chronicles (as reconstructed independently of the extrabiblical evidence). This is not to say that there are no errors in the reconstruction or in the presumed original synchronisms, but only that the data appears to be very close to the historical reality.

Table 4.14: Comparison of Extrabiblical Dates with Chronicle Dates for the Kings of Judah

Extrabiblical Synchronisms	Chronicle Dates
Sometime during the reign of Shoshenq I of Egypt (c. 945-925) = Year 5 of Rehoboam. Match	→ Rehoboam (934-917) Abijam (917-911) Asa (911-870) Jehoshaphat (870-848) Jehoram (848-842) Ahaziah (842-841) Jehoash (841-798) Amaziah (798-782)
64 years before Esarhaddon of Assyria deports the population of Phoenicia-Samaria (740 or 739) = sometime in the reign of Ahaz. Match	→ Ahaziah (782-742) Jotham (742-740)
Year 11, 12 or 13 of Tiglath-pileser III of Assyria (735, 734 or 733) = sometime in the reign of Ahaz. Match	→ Ahaz (740-726)
Soon after the death of Tiglath-pileser III of Assyria (727 or 726) = accession of Hezekiah. Match	→ Hezekiah (726-)
Year 5 of Shalmaneser V of Assyria (722) = Year 4 of Hezekiah. Match	→
Year 2 of Sargon of Assyria (720) = Year 6 of Hezekiah. Match	→
10 of Sargon of Assyria (712) = Year 14 of Hezekiah of Judah. Match	→
sometime in the reign of Marduk-apla-iddina II of Babylon (722-710) = Year 14 of Hezekiah. Match	→
Year 4 of Sennacherib of Assyria (701) = sometime in the reign of Hezekiah of Judah. Match	→

²³¹ In this one case, I was forced to rely on the reign total from the Judahite king list.

**Table 4.15: Comparison of Extrabiblical Dates
with Chronicle Dates for the Kings of Israel**

Extrabiblical Synchronisms	Chronicle Dates
	Jeroboam (934-910) Nadab (910-909) Baasha (909-892) Elah (892-886) Zimri (886) Omri (886-874)
Year 6 of Shalmaneser III of Assyria (853) = sometime in the reign of Ahab of Israel. Match	→ Ahab (874-853) Ahaziah (853-852) Jehoram (852-841)
Year 18 of Shalmaneser III of Assyria (841) = sometime in the reign of Jehu of Israel. Match	→ Jehu (841-814)
Sometime in the reign of Adad-nirari III of Assyria (811-783) = sometime in the reign of Joash of Israel. Match	→ Jehoahaz (814-800) Joash (800-796)
Sometime in the reign of Tiglath-pileser III of Assyria (743, 740, or 738) = sometime in the reign of Menahem of Israel. Match	→ Jeroboam (796-756) Zechariah (756) Shallum (755)
Year 15 or 17 of Tiglath-pileser III of Assyria (731 or 729) = coronation of Hoshea of Israel. Match	→ Menahem (755-743) Pekahiah (743-742) Pekah (742-729) → Hoshea (729-720)

It is clear, therefore, that the synchronisms are more reliable historically than the figures in the king lists and should be used first and favored when attempting to put together an accurate chronology.

V.

CONCLUSIONS

This study has examined ancient Israelite measurement of both circular time (the calendar) and linear time (historical chronology). With regard to the former, a careful reading of all of the sources has revealed the existence of more than one calendar in ancient Israel and Judah. An *agricultural* calendar divided the year into two main parts, seedtime (winter) and harvest (summer). Seedtime began in mid-November and ran to mid-April, while the harvest (much longer) ran from mid-April to mid-November. The Judahite *civil* year commenced around the time of the autumnal equinox (mid-September), and, at least in the early period, the civil year in northern Israel began at the same time. The *liturgical* calendar of the Aaronid priests began in the spring, but the priestly texts acknowledge the existence of a civil year beginning in the autumn. Evidence for a regnal year beginning in the autumn in the latter days of Judah suggests that there was no separate regnal calendar, but that king's reigns were calculated according to the civil year. Although at first the northern Israelites too began their civil year in the autumn (as indicated by the Gezer Calendar), the evidence that the regnal years in Samaria were most likely counted from the spring indicates that its civil year was changed sometime after the North's secession from the Davidic kingdom. At the time the Deuteronomistic History was published (in the reign of Josiah), Judah was celebrating both the beginning of its civil year *and* the end of its agricultural year in the autumn. This suggests that sometime prior to Josiah, Judah made an attempt to harmonize its civil and

agricultural years. Israel, on the other hand, continued to maintain an agricultural calendar separate from its civil one.

Because of the evidence that the phases of the moon were observed by both priestly and non-priestly organizations, and that their seasonal events occurred at the same time each year, we can confidently assume that the lunisolar calendar was standard. Although we have no direct evidence from the Bible, the Israelites probably would have used the common ancient Near Eastern system of intercalation: each year contained 12 months, and every three years or so, the New Year would be delayed so that one more month could pass.

The appearance of the month name Abib in several early sources indicates that the Israelites named their months at one time. This does not mean, however, that the names were borrowed from a Canaanite calendar. The month names may have been unique to Israel. An extrabiblical inscription from the 8th century appears to be our earliest evidence of pre-exilic usage of numbered months.²³² The custom of referring to months by number is evident in both P and Dtr. However, it would seem that the parts of Dtr that do this are of exilic provenance. P's month references are limited to the ritual calendar and may be pre-exilic.

All of the major sources assume a day that begins and ends at sunrise. The broad agreement suggests that this was a general view for a long period of time. P, however, appears to have a different system of reckoning the day when it comes to rituals of the cult. The liturgical day began at sunset.

²³² See Cross, "A Fragment of a Monumental Inscription from the City of David," 44-47.

The only possible reference to a clock in the Hebrew Bible is found in the narrative of 2 Kings 20:8-11 (= Isaiah 38:22, 7-8). If so, the clock described is comparable to shadow clocks used in ancient Egypt. The device seems to have been set up at the king's palace to measure the passing of the day by the sun's shadow. Each step represented a division of time: ten steps on one side for the first half of the day, and ten on the other for the second half of the day. The average is approximately 36 minutes per step, but the time would have varied depending on the time of year (shorter during the winter and longer during the summer). A division of the daytime into 20 units is unattested in the sources of any other ancient culture. If so, we may have here a uniquely Judahite clock.

In the measurement of linear time, the ancient Israelites employed the following principles of counting:

1) All individual units of time (day, months, years, etc.) were added inclusively; in other words, they did not use a zero, so the first unit in a sequence bore the number one.

2) Multiple years were not organized into convenient units of set length, such as decades, centuries, or millenniums. Blocks of time were created as it suited the calculator. The units in a block were counted individually (1, 2, 3, 4...) and measured from an important date (the birth of a famous person, the accession of a ruler, or a significant event), and end at an important date.

3) Despite the inclusive system of counting individual time units, when adding together two or more blocks of time, the Israelites did not overlap them. The second block begins to be counted on its first unit, and not on the last unit of the first block.

4) Generations seem to have been counted differently in ancient Israel than they are today. Instead of considering *parents* as the first generation, the Israelites reckoned *children* as the first generation, grandchildren as the second, etc.

The counting of years is a prominent feature of two of the ancient histories of Israel (P and Dtr). P employs a system of chronology based on the births of important people (genealogical in nature). Dtr employs a system or systems based on the terms of judges and kings.

The priestly chronology dates events that occur prior to the Exodus by placing them within a specific year in the lifetime of an individual. P's chronological framework, which anchors its dates to an absolute chronology, is spread throughout Genesis, but is concentrated in chapters 5 and 11, where we can see its basic form. In those chapters we find lists of ancestors. The information provided for each ancestor is his age at the birth of a significant son, his age at death, and the length of time between these two events. These lists form a pedigree running from Adam to Jacob.

The variant figures found in Genesis 5 and 11 in the manuscript traditions are the results of scribes dealing with chronological problems in the text. In the earliest manuscripts, the date for the Flood (the 600th year of Noah) was in conflict with the basic genealogical chronology found in Genesis 5 (the ages of the fathers at the births of their sons). Three of the antediluvian patriarchs (Jared, Methuselah, and Lamech) were given life spans in the genealogical chronology that placed their deaths after the Flood (i.e., after Noah's 600th year). According to the narrative, their survival of the Flood would be an impossibility (Gen 7:23). The chronological problems apparently went unnoticed by the original editor, but scribes from different manuscript traditions attempted to alleviate

the difficulties in their own ways, and their activity explains the variations in the manuscripts. Thus the Flood date (the 600th year of Noah) is likely to have been taken from a different source than the genealogical data. Yet in the present text the Flood date and the genealogy are interwoven and mathematically dependent on one another. The inference is that the author/editor of P was working with two chronologies and attempting to fit them together. This would mean all the data in P's genealogical chronology do not come from a single source, but probably from two.

In regard to the two written sources from which the priestly author/editor theoretically drew (which most likely go unnamed), the first seems to have contained a generational chronology, running from Adam to Terah, that provided the age of each father at the birth of his son, and the other, which contained a date for the Flood (the 600th year of Noah), was part of a different chronology that provided the long life spans of the patriarchs from Adam to Jacob. With their combination, accommodations had to be made: Noah's and Shem's birthdates had to be changed. Moreover, there were no birthdates for Abraham, Isaac, and Jacob, so these were supplied in accordance with the P author's conception of the length of time spanning Terah's and Joseph's lives.

In regard to the historical chronology of the Deuteronomistic History, I have presented evidence that the original version of the DH (Dtr¹) contained a limited amount of chronological information and that the second edition (Dtr²) added much more to the History and systematized its chronology.

An examination of the Book of Judges revealed that the numbers associated with the periods of oppression were not created by the same editor/author as the one who devised the figures for the 40-year periods of peace. The original editor employed round

numbers to cover periods between events and did not seem interested in accounting for every time period. He did possess a source document with chronological information that he saw fit to include, but it covered the terms of only a few judges. Dtr¹'s rough chronology was supplemented and schematized by the reviser of the History. This had the effect of lengthening the period of the Judges.

An analysis of the regnal formulas in Kings has revealed the existence of a source document, a list of the kings of Judah from Rehoboam to Zedekiah containing specific information about each of the kings—most importantly their reign lengths. The final six entries in the list appear to have been added later. The original version of this king list would have ended with Manasseh, and because it recorded his full reign length, must be dated after his death. However, since Manasseh's son and successor Amon did not appear in the list, it probably was composed before the death of Amon. Thus the list is datable to the reign of Amon. The uniformity in the final six entries suggests a single author for the additions, one who possessed information about the final king of Judah and who therefore would have composed all six entries after the destruction of Jerusalem in 586 BCE. These factors indicate that the Josianic Deuteronomistic Historian did not possess this Judahite king list in either its long or short form, and that the information it contained was not put into the DH until the exile.

As in the case of the Judahite kings, the exilic reviser of the history may have had at his disposal a list of the names of the kings of Israel and the total years of their reigns in a separate document. He incorporated this data into the exilic edition of the DH.

The synchronistic formulations in the DH, which bear the pattern, "In the [#] year of PN, [a certain event happened]," suggest that they come from a royal chronicle, and

since the dates are associated with the kings of both kingdoms, it is best to posit two such chronicles, a Judahite and an Israelite one. These are no doubt to be equated with *The Scroll of the Affairs of the Days for the Kings of Judah* and *The Scroll of the Affairs of the Days for the Kings of Israel* that the historian cites. The synchronisms were an integral part of the pre-exilic edition of the DH.

Thus we have found that the Josianic version of the Deuteronomistic History contained chronological data only from the Judahite and Israelite royal chronicles, which placed events in specific regnal years, but did not provide totals for the length of kings' reigns. The total counts for kings' reigns were added to the DH during the exile and derive from king lists that were not directly connected with the royal chronicles.

Textual analysis of the manuscripts of Kings has shown that the royal chronicles that contained the synchronisms must have presented a different chronology than the king lists. The contradictions between the reign lengths and the synchronisms were ignored by the exilic reviser of the Deuteronomistic History. It would appear that the variants in MT and LXX arose when later scribes noted the contradictions and tried to fix the discrepancies.

The final endeavor in this study was to compare the historical credibility of the reign lengths from the king lists and the synchronisms from the royal chronicles. To do this, we needed to ascertain whether the chronicles were based on an accession-year or non-accession year system. The Israelite royal chronicle used for the first edition of the DH points to a non-accession year system (antedating). The Judahite royal chronicle provides no direct evidence, but the Judahite king list assumes an accession-year system in Judah, and this suggests that, at least in the latter days of the monarchy in Judah, an

accession-year system was used. How early this practice was begun is unknown, but since the Judahite royal chronicle used by the Deuteronomistic Historian would have been a late monarchic document, we should expect that it assumed an accession-year system as well. Using this information, a chronology was reconstructed from the synchronisms.

A comparison with extrabiblical synchronisms demonstrated that the numbers from both the Israelite king list and the Judahite king list are defective. The reigns of the kings do not coincide with the historical reality very well at all, particularly those of the early kings. A similar comparison of the extrabiblical synchronisms with the information from the royal chronicles revealed that the chronological material of the chronicles is much closer to the historical reality.

Appendix A: Chronological Tables

A. The Priestly Timeline of History

The original chronology of P, prior to adjustments/corrections made by R would have been as follows (years are Anno Mundi):

Adam (1-930)
Seth (130-1042)
Enosh (235-1140)
Kenan (325-1235)
Mahalalel (395-1290)
Jared (460-1422)
Enoch (522-887)
Methuselah (587-1556)
Lamech (654-1431)
Noah (707-1657)
Shem (1207-1807)
Flood (1307)
Arpachshad (1307-1745)
Shelah (1342-1775)
Eber (1372-1776)
Peleg (1406-1645)
Reu (1436-1675)
Serug (1468-1698)
Nahor (1498-1646)
Terah (1527-1732)
Abraham (1597-1772)
Isaac (1697-1877)
Jacob (1757-1904)
Entry into Egypt (1887)
Exodus (2317)
Wilderness Wanderings (2317-2357)

B. Two Deuteronomic Chronologies

The separation of two conflicting chronologies in the Deuteronomistic History not only enables us to distinguish between the chronologies of the sources used by the compilers of the History, but also helps us to understand the way Israelite and Judahite

history was perceived by the Josianic Deuteronomistic Historian, on the one hand, and the exilic reviser of the DH, on the other.

The second edition of the History makes an effort to be complete and definitive in its chronology. It incorporates figures from the first edition, but often reinterprets them (as in the case of the terms of the Judges) or ignores them in favor of new data (as in the reigns of the kings). A historical timeline of Israel's history from the point of view of the exilic reviser of the DH may be put together without much difficulty.

Table A.1: Chronology of Dtr²

Period	Length of Period	Years BCE
Moses and Joshua (Josh 14:10)	44 yrs (45 minus 1)	1488-1444
Aramean oppression (Judg 3:8)	8 yrs	1444-1436
Rest (Judg 3:11)	40 yrs	1436-1396
Moabite oppression (Judg 3:14)	18 yrs	1396-1378
Rest (Judg 3:3)	80 yrs	1378-1298
Canaanite oppression (Judg 4:3)	20 yrs	1298-1278
Rest (Judg 5:31)	40 yrs	1278-1238
Midianite oppression (Judg 6:1)	7 yrs	1238-1231
Rest (Judg 8:28)	40 yrs	1231-1191
Abimelech (Judg 9:22)	3 yrs	1191-1188
Tola (Judg 10:2)	23 yrs	1188-1165
Jair (Judg 10:3)	22 yrs	1165-1143
Ammonite oppression (Judg 10:8)	18 yrs	1143-1125
Jephthah (Judg 12:7)	6 yrs	1125-1119
Ibzan (Judg 12:8)	7 yrs	1119-1112
Elon (Judg 12:11)	10 yrs	1112-1102
Abdon (Judg 12:14)	8 yrs	1102-1096
Philistine oppression (Judg 13:1)	40 yrs (20 of which Samson was judge [Judg 15:20], 20 of which Samuel was judge [1 Sam 7:13])	1096-1056
Saul (1 Sam 13:1)	2 yrs	1056-1054
David (1 Ki 2:11)	40 yrs	1052-1012
Solomon until Temple (1 Ki 6:1)	3 yrs	1012-1009
<i>Total from Exodus to Temple (1 Kings 6:1)</i>	479 yrs	1488-1009

Table A.1 continued

Solomon after Temple (1 Ki 11:42)	36 yrs	1009-973
Rehoboam	17 yrs	973-956
Abijam	3 yrs	956-953
Asa	41 yrs	953-912
Jehoshaphat	25 yrs	912-887
Jehoram	8 yrs	887-879
Ahaziah	1 yr	879-878
Jehoash	40 yrs	878-838
Amaziah	29 yrs	838-809
Azariah	52 yrs	809-757
Jotham	16 yrs	757-741
Ahaz	16 yrs	741-725
Hezekiah	29 yrs	725-696
Manasseh	55 yrs	696-641
Amon	2 yrs	641-639
Josiah	31 yrs	639-608
Jehoahaz	3 mos.	608
Jehoiakim	11 yrs	608-597
Jehoiachin	3 mos.	597
Zedekiah	11 yrs.	597-586

The chronology of the first edition of the DH is limited, and apart from the figures incorporated from the sources (four were used: a list of judges with term lengths, a chronicle containing dates associated with Solomon's building projects, a kingly chronicle from Judah, and a kingly chronicle from Israel), the author provides little other chronological data, and when he chooses to, the numbers are mere estimates, which he offers unapologetically.

We can reconstruct the chronology of the original Deuteronomistic History as follows:

Table A.2: Chronology of Dtr¹

Period	Length of Period	Years BCE
Moses and Joshua (Josh 14:10)	44 years (45 minus 1)	1464-1420
One generation (Judg 2:10)	40 yrs	1420-1380
Othniel (Judg 3:11)	40 yrs	1380-1340
Ehud and Shamgar (Judg 3:3)	80 yrs	1340-1260
Deborah (Judg 5:31)	40 yrs	1260-1220
Gideon (Judg 8:28)	40 yrs	1220-1180

Table A.2 continued

Abimelech	[10] yrs	1180-1170
Tola (Judg 10:2)	23 yrs	1170-1147
Jair (Judg 10:3)	22 yrs	1147-1125
<i>Total from entry into Canaan to Jephthah (Judg 11:26)</i>	299 yrs (300 minus 1)	1424-1125
Jephthah (Judg 12:7)	6 yrs	1125-1119
Ibzan (Judg 12:8)	7 yrs	1119-1112
Elon (Judg 12:11)	10 years	1112-1102
Abdon (Judg 12:14)	8 yrs	1102-1094
Samson (Judg 16:31)	20 yrs	1094-1074
Samuel	none stated (40 yrs?)	1074-1034
Saul	none stated (20 yrs?)	1034-1014
David (1 Kings 2:11)	40 yrs	1014-974
Solomon (1 Kings 11:42)	40 yrs	974-934
Rehoboam	17 yrs	934-917
Abijam	6 yrs	917-911
Asa	41 yrs	911-870
Jehoshaphat	22 yrs	870-848
Jehoram	6 yrs	848-842
Ahaziah	undiscernible (1 yr?)	842-841
Jehoash	38 yrs	841-798
Amaziah	18 yrs	798-782
Azariah	53 yrs	782-742
Jotham	15 yrs	742-740
Ahaz	14 yrs	740-726
Hezekiah	29 yrs	726-697
Manasseh	undiscernible (55 yrs?)	697-642
Amon	undiscernible (2 yrs?)	642-640
Josiah until reform	18 yrs	640-622

In a few instances, educated guesses had to be made, so it is impossible at this time to reconstruct Dtr¹'s chronology with absolute certainty. The Deuteronomistic Historian's chronology runs slightly shorter than does that of the exilic reviser. Historically speaking, the dates in the period of the kings are probably not far off base, but the period of the judges is overextended by quite a bit, a consequence of the Deuteronomistic Historian's attribution of a full generation for each judge (and perhaps for Saul, David, and Solomon too). Apart from the list of the minor judges, he had very little chronological information to go on.

C. THE JUDAHITE KING LIST: Translation

Saul was [] years old at his accession, and he reigned 2 years over Israel.

David was 30 years old at his accession, and he reigned 40 years. He reigned over Judah 7 years in Hebron, and he reigned over all Israel and Judah 33 years in Jerusalem.

[Solomon was ... years old at his accession, and he reigned ... years in Jerusalem.]

[Rehoboam] was 41 years old at his accession, and he reigned 17 years in Jerusalem..., and his mother's name was Naamah the Ammonitess.

[Abijam] reigned 3 years in Jerusalem, and his mother's name was Maacah the daughter of Abishalom.²³³

[Asa] reigned 41 years in Jerusalem, and his mother's name was Maacah the daughter of Abishalom.

Jehoshaphat was 35 years old at his accession, and he reigned 25 years in Jerusalem, and his mother's name was Azubah the daughter of Shilhi.

[Jehoram] was 32 years old at his accession, and he reigned 8 years in Jerusalem.

Ahaziah was 22 years old at his accession, and he reigned 1 year in Jerusalem, and his mother's name was Athaliah, the daughter of Omri the king of Israel.

Jehoash was 7 years old at his accession..., and he reigned 40 years in Jerusalem, and his mother's name was Zibiah from Beersheba.

[Amaziah] was 25 years old at his accession, and he reigned 29 years in Jerusalem, and his mother's name was Jehoaddin of Jerusalem.

[Azariah] was 16 years old at his accession, and he reigned 52 years in Jerusalem, and his mother's name was Jecoliah of Jerusalem.

[Jotham] was 25 years old at his accession, and he reigned 16 years in Jerusalem, and his mother's name was Jerusha the daughter of Zadok.

[Ahaz] was 20 years old at his accession, and he reigned 16 years in Jerusalem.

[Hezekiah] was 25 years old at his accession, and he reigned 29 years in Jerusalem, and his mother's name was Abi, the daughter of Zechariah.

²³³ LXX reads "6 years" as the length of reign. For the argument in favor of MT's reading, see above.

Manasseh was 12 years old at his accession, and he reigned 55 years in Jerusalem, and his mother's name was Hephzibah.

Amon was 22 years old at his accession, and he reigned 2 years in Jerusalem, and his mother's name was Meshullemeth, the daughter of Haruz from Jotbah.

Josiah was 8 years old at his accession, and he reigned 31 years in Jerusalem, and his mother's name was Jedidah, the daughter of Adaiah from Bozkath.

Jehoahaz was 23 years old at his accession, and he reigned 3 months in Jerusalem, and his mother's name was Hamutal, the daughter of Jeremiah from Libnah.

Jehoiakim was 25 years old at his accession, and he reigned 11 years in Jerusalem, and his mother's name was Zebidah, the daughter of Pedaiah from Rumah.

Jehoiachin was 18 years old at his accession, and he reigned 3 months in Jerusalem, and his mother's name was Nehushta, the daughter of Elnathan of Jerusalem.

Zedekiah was 21 years old at his accession, and he reigned 11 years in Jerusalem, and his mother's name was Hamutal, the daughter of Jeremiah from Libnah.

Appendix B: What Happened in the Fourteenth Year of Hezekiah? A Historical Analysis of 2 Kings 18-20 in the Light of New Textual Considerations

A. Introduction

The Second Book of Kings explicitly states that in Hezekiah's fourteenth regnal year the Assyrian king Sennacherib came up against Judah (18:13). Sennacherib's annals likewise record this event, placing it in his own fourth year, for which the commonly accepted date is 701 B.C.E.²³⁴ Seemingly, then, we have a concrete synchronism: the 14th year of Hezekiah = the 4th year of Sennacherib. However, 2 Kings also says that only eight years prior to Sennacherib's invasion, in the *sixth* year of Hezekiah, the kingdom of Samaria fell to the Assyrians (2 Kgs 18:10). The historical records of Assyria, through which a firm year-by-year chronology can be fixed, will not allow for such a short span of time between the two events. Although the *exact* date for the fall of Samaria has been disputed, it definitely occurred between the final year of Shalmaneser V (722 B.C.E.) and the second year of his successor Sargon II (720 B.C.E.). Samaria's overthrow, therefore, is separated from the fourth year of Sennacherib by some 20 years.²³⁵ It is no wonder, then, that historians have been wrangling over the discrepancy for over a century.²³⁶ Since there is no way to squeeze the events of twenty well-attested years into a mere eight, most have concluded either that Samaria did not fall in Hezekiah's sixth year or that Sennacherib did not invade Judah in Hezekiah's fourteenth

²³⁴ A. Millard, *The Eponyms of the Assyrian Empire 910-612 BC* (State Archives of Assyria Studies 2; Helsinki: Neo-Assyrian Text Corpus Project, 1994) 12-14, 60; M. Cogan and H. Tadmor, *II Kings* (Anchor Bible 11; Garden City, N.Y.: Doubleday, 1988) 246-51.

²³⁵ Epigraphs from the time of Sargon II confirm that the length of his reign was no less than 16 years.

²³⁶ For an introduction to the problem, see Childs, *Isaiah and the Assyrian Crisis* (Studies in Biblical Theology, Second Series No. 3; London: SCM Press, 1967) 11-12.

year.²³⁷ Either way, it is assumed that one of the chronological tags in the biblical account is inaccurate.²³⁸

With so much written on this conundrum, it would appear that every angle has been considered and that all possible solutions have been duly examined. Before we resign ourselves to choosing and rationalizing one of the existing hypotheses, however, let us return to the heart of the issue to see whether we may make any further progress in unraveling the difficulties. Previous observations regarding the pertinent biblical passages will need to be noted, but new textual and historical considerations may aid us in calculating the temporal placement of the events recorded in 2 Kings 18-20 and in shedding further light on this interesting period in Israelite and Assyrian history.

B. Two Narratives

In the text of Kings, the passage dealing with the Assyrian campaign against Judah begins thus:

¹³In the fourteenth year of King Hezekiah, Sennacherib the king of Assyria came up against all the fortified cities of Judah and seized them. ¹⁴*Hezekiah, the king of Judah, sent a message to the king of Assyria at Lachish as follows: 'I have transgressed. Withdraw from me [and] whatever you impose upon me, I shall bear.'* ¹⁵*So the king of Assyria required from Hezekiah, the king of Judah, 300*

²³⁷ For a survey of the opinions, see Galil, *The Chronology of the Kings of Israel and Judah* (Studies in the History and Culture of the Ancient Near East 9; Leiden: E. J. Brill, 1996) 99.

²³⁸ An alternative argument has also been offered which attempts to reconcile the biblical data by suggesting that a coregency existed between Hezekiah and his father Ahaz and that the statement at 2 Kgs 18:1 refers to Hezekiah's becoming coregent (e.g., Na'aman, "Historical and Chronological Notes on the Kingdoms of Israel and Judah in the Eighth Century B.C.," *Vetus Testamentum* 36 [January 1986] 84-5, 90). But see Galil (*Chronology*, 99-102), for the problems with this theory.

silver talents and 30 gold talents. And Hezekiah gave all the silver that was to be found at the house of Yhwh and in the treasury of the king's palace. ¹⁶(At that time Hezekiah stripped the doors of the house of Yhwh and the doorposts which Hezekiah, the king of Judah, had plated and delivered them to the king of Assyria.)

¹⁷The king of Assyria sent the viceroy, the chief eunuch, and the chief attendant from Lachish to King Hezekiah with a large military force to Jerusalem

.....

(2 Kgs 18:13-17a)

Others have convincingly argued that the section here italicized (vv. 14–16) is derived from a source separate from the main narrative, verses 14-15 perhaps stemming from the state annals of Judah.²³⁹ The parenthetical statement (v. 16) may come from a Temple chronicle.²⁴⁰ Interpreters have often remarked that there are perceptible differences in style between verses 14-16 and the material that surrounds them. The usual observation is that the information provided in these verses is factual, concise, void of

²³⁹ See L. L. Honor, *Sennacherib's Invasion of Palestine: A Critical Source Study* (Contributions to Oriental History and Philology 12; New York: Columbia University Press, 1926) 36-7. There is clear evidence that the Books of Kings contain extracts from annals, as they frequently refer to the Book of the Annals of the Kings of Judah as a source. (In this case, see 2 Kgs 20:20.) This source book may have been kept in the government archives. This is not to say that all accept this view. J. H. Hull (*Hezekiah, Saint and Sinner: A Conceptual and Contextual Narrative Analysis of 2 Kings 18-20* [Ph.D. diss., Claremont Graduate School, 1994] 91-2) for example, draws attention to the fact that these citations are usually presented as rhetorical questions, and thus cannot be used to prove that the writer drew from the source he mentions. However, the expression *הנם כהובים* in some of these citations (1 Kgs 14:19; 2 Kgs 15:11, 15, 26, 31) implies that the documents were readily available, and there is every reason to believe that the writer would have made use of them.

²⁴⁰ The existence of a Temple chronicle is only hypothetical, but the introductory statement "at that time" may indicate a second excerpt. Still, this excerpt may not necessarily be from a different source, but from a different location in the same source (Childs, 70-1; F. J. Gonçalves, *L'expédition de Sennachérib en Palestine dans la littérature hébraïque ancienne* [Louvain-la-Neuve: Université catholique de Louvain, Institut orientaliste, 1986] 361-63).

embellishments, and written from a political perspective, just as one might find within a state document.²⁴¹ In other words, no attempt is made to color the episode to suit a particular bias, as might be expected if the passage came directly from the hand of the person who composed the main body of narrative.²⁴² The section that follows, in direct contrast to this, is a theologically-driven dramatic presentation in the usual style of the book.²⁴³ However, making an assessment of source derivation on the basis of style is a precarious undertaking. Of more weight and significance would be linguistic features in verses 14-16 that distinguish these verses from the rest of the text. We see such a difference in the manner in which Hezekiah's name is presented. In the surrounding narrative, the king of Judah's name is regularly spelled חֲזַקְיָהוּ. The portion of the text under analysis, however, spells the name חֲזַקְיָה in every instance.²⁴⁴ Furthermore, it uses the appellation "Hezekiah, the king of Judah" (חֲזַקְיָה מֶלֶךְ יְהוּדָה), a formal title, rather than "King Hezekiah" (הַמֶּלֶךְ חֲזַקְיָהוּ), an epithet of familiarity. The latter appellation is the favored designation for the king of Judah in the material immediately before and after verses 14-16.²⁴⁵ I believe the presentation of the names is a key to establishing sources in the text and that, by ascertaining these sources, a solution to the chronological problem will begin to manifest itself.

²⁴¹ Gonçalves, 367-70.

²⁴² The passage might be construed as anti-Hezekiah in view of his disfigurement of the Temple, but no judgments are made about Hezekiah's actions within the excerpt itself. (How the passage is used by the Deuteronomistic historian is another matter.)

²⁴³ It may also be significant that the parallel account of Sennacherib's invasion in the book of Isaiah, which is almost an exact duplicate of the Kings version, entirely omits the small section equivalent to 2 Kgs 18:14-16 (see Isa 36:1-2), but it is more likely that the passage is missing in Isaiah as a result of haplography (וישלח ן וישלח).

²⁴⁴ The only two other occurrences of this spelling are at 2 Kgs 18:1 and 10, whose statements might also come from the same source document.

²⁴⁵ Cogan and Tadmor, 228, 240-1.

Since the beginning of verse 13 uses the epithet “King Hezekiah,” it may be attributed to a source other than that of verses 14-16 and associated instead with the main body of narrative.²⁴⁶ There has been some question over the origin of the *second half* of verse 13 (“Sennacherib the king of Assyria came up against all the fortified cities of Judah and seized them”). There are indications that it has a stronger kinship with verses 14-16 than with 13a. For instance, the epithet “Sennacherib, the king of Assyria” (סנחריב מלך אשור) matches the form “Hezekiah, the king of Judah” (חזקיה מלך יהודה) found in verses 14 and 16. Additionally, verses 14-16 cannot stand by themselves. They require an introductory statement, not only to provide a setting for the report, but also to explain Hezekiah’s capitulation.²⁴⁷ All three-and-a-half verses (13b-16) make a suitable parallel with the passage in Sennacherib’s own annals dated to his fourth year. Sennacherib describes the event this way:

(As for) Hezekiah the Judaeon (who had not submitted to my yoke), I surrounded and conquered 46 of his strongly fortified walled cities and countless small towns in their vicinity by stamping down siege ramps, bringing up battering rams, the relentless attacks of footsoldiers, bored holes, breaches, and picks. I brought out of their midst 200,150 people, small and big, male and females, horses, wild asses, donkeys, camels, oxen and sheep without number and I classified (them) as spoil.

(As for) him, I enclosed him like a bird in a cage in the midst of Jerusalem, his royal city. I erected fortresses against him and made it unthinkable for him to go out of the gate of his city. His cities, which I had despoiled, I cut off from his land and gave to Mitinti, king of Ashdod, Padi,

²⁴⁶ It is true that Leningrad codex B 19a reads חזקיה in this location, and this form was adopted in the 3rd edition of BHK and in BHS. However, in all other instances within the Hezekiah narratives, חזקיה, not חזקיה, follows immediately after המלך, and it is significant that the parallel verse at Isa 36:1 contains the longer form in all extant manuscripts except 4QIsa^a. The similar phrase at 2 Kgs 18:9a, also encourages acceptance of the longer spelling at 18:13a, which is attested in the first two editions of BHK, in Jacob ben Hayyim’s “Bomberg Edition” (1524-5), and in all the Kennicott manuscripts prior to 1200 (See Norin, “An Important Kennicott Reading in 2 Kings XVIII 13,” *Vetus Testamentum* 32 (1982) 337-8; also A. Laato “Hezekiah and the Assyrian Crisis in 701 B.C.,” *Scandinavian Journal of the Old Testament* 2 [1987] 50).

²⁴⁷ Gonçalves, 360. It is true that the person who incorporated the annals extract into the text could have simply used a fragment of the account without the proem, but it would have been more natural for him to have included the statement that introduced the setting for the event.

king of Ekron, and Sil-Bel, king of Gaza. I (thus) reduced his land. To the earlier tax, their annual payment, I added tribute (and) gifts for my lordship and imposed (these) upon them.

(As for) him, Hezekiah, the fear of the radiant splendor of my lordship overwhelmed him and he sent after me to Nineveh, my capital, ambushers and his select troops whom he had brought in to strengthen Jerusalem, his royal city, and whom he had acquired as auxiliary troops, (as well as) 30 talents of gold, 800 talents of silver, choice antimony, large blocks of carnelian, beds (inlaid) with ivory, armchairs (inlaid) with ivory, elephant hide, ebony, boxwood, garments with multi-colored trim, linen garments, blue-purple wool, red-purple wool, utensils of copper, iron, bronze, tin and iron, chariots, shields, lances, coats of mail, swords on belts, bows and arrows, tillu-equipment, instruments of war without number along with his daughters, his palace women, and male and female singers – and, in order to deliver the tribute and to carry out his servitude, he dispatched his messenger.²⁴⁸

The correspondence between the two accounts, although not exact, is remarkable.

Particularly noteworthy is the agreement in a number of details, such as the general terms of the tribute. Both accounts mention the 30 talents of gold; and although the silver amount is greater in the Assyrian record, the biblical source seems to indicate that Hezekiah gave more silver than was demanded of him. Did Sennacherib require *all* the silver that was in the Temple and in the palace?²⁴⁹ Some have played down the similarities between the two sources in an attempt to cast doubt on the annalistic origin of the biblical passage,²⁵⁰ but most scholars accept that the biblical report at 2 Kgs 18:13b-16 was drawn from a contemporary document of equal historical weight with the Assyrian source and believe the two can be harmonized. It thus seems best to take verse

²⁴⁸ From the Rassam Cylinder (700 B.C.E.). The translation is William R. Gallagher's (*Sennacherib's Campaign to Judah: New Studies* [Studies in the History and Culture of the Ancient Near East 18; Leiden: Brill, 1999] 129-30).

²⁴⁹ Cogan and Tadmor, 229.

²⁵⁰ For example, C. R. Seitz (*Zion's Final Destiny: A Reassessment of Isaiah 36-39* [Minneapolis: Fortress Press, 1991] 47-66, esp. 61-6), whose main purpose is to prove the priority of Isaiah's version over that of Kings. J. B. Geyer ("2 Kings XVIII 14-16 and the Annals of Sennacherib," *Vetus Testamentum* 21 [1971] 604-6) does also, but only in order to point out that there is not an *exact* correspondence between the Assyrian and biblical sources.

13b as part of the pericope that includes verses 14-16²⁵¹ and to consider these three-and-a-half verses to be accessory to the main narrative. (For convenience, we shall follow scholarly convention and refer to verses 13b-16 as segment A throughout the remainder of this discussion.)

Oddly, the Assyrian record agrees *only* with segment A, while the rest of the narrative in chapters 18 and 19 has no parallel in the Assyrian sources. Although the Assyrian report is a typical example of Assyrian propaganda, and it is probable that Sennacherib deliberately omitted any information that would present him in a bad light,²⁵² little of what is described in Kings would have embarrassed Sennacherib apart from his inglorious defeat at 2 Kgs 19:35, 36. So the omission of a great number of details on the Assyrian side makes for a noteworthy discrepancy between sources.

We are now left to ponder the significance of verse 13a. Although it appears to be written specifically as an introduction to segment A, we might wish to consider the possibility that it was not originally linked to segment A. As has been mentioned above, verse 13a cannot refer to Sennacherib's campaign in his fourth year without disrupting the chronological statement at 2 Kgs 18:1. It simply does not fit where it is currently situated, at least from a historical standpoint. Thus verse 13a has become a notorious crux because no one knows for sure to what the chronological statement "in the fourteenth year of King Hezekiah" applies. Interestingly, there is a passage nearby which is indeed set in that year, the account of Hezekiah's illness in Chapter 20. We know that the events of Chapter 20 are supposed to have taken place in Hezekiah's fourteenth year,

²⁵¹ For a discussion of the issue, see Honor, 37-40.

²⁵² See the excellent article by A. Laato, "Assyrian propaganda and the falsification of history in the royal inscriptions of Sennacherib," *Vetus Testamentum* 45 (1995) 198.

because on that occasion he is granted another fifteen years of life, and the total length of his reign is given as 29 years (14+15=29).²⁵³

Some have suggested that verse 13a originally introduced chapter 20.²⁵⁴ But Chapter 20 possesses an opening chronological statement of its own (“In those days”), and there is no textual evidence to suggest it is not original. Non-specific temporal expressions such as **בִּימֵי הַהֵם** (“In those days...”), **בְּעֵת הַהִיא** (“At that time...”), etc., do not introduce major structural units in the narrative but are coordinating clauses that mark *a turning point* within a story and refer back to a previous date formula.²⁵⁵ The events of Chapter 20 are clearly subordinate to a more momentous series of events. Therefore we may view the account in Chapter 20 as part of a longer narrative, for which 18:13a provides the temporal setting. We should also expect, between 18:13a and 20:1, a major episode that would recount the principal set of circumstances in which Chapter 20 plays a part. So the question is: How much of Chapters 18 and 19 are part of the original tale?

The invasion of Sennacherib as described in verses 13b-16 cannot be viewed as the original setting for Hezekiah’s illness. I have already pointed out the linguistic dissimilarities between segment A and the narrative in which it is embedded, as well as the chronological problem. But still other factors alienate the passage from its context. The succession of events from verses 13b-16 into verse 17 is unnatural. Why would Sennacherib send his officials to demand unconditional surrender of Jerusalem immediately after Hezekiah made peace with him by way of a substantial tribute? Every indication is that Sennacherib accepted this tribute and was appeased. In a similar vein,

²⁵³ 2 Kgs 18:2. See Cogan and Tadmor, 228.

²⁵⁴ Cogan and Tadmor, 228.

why would Hezekiah willingly yield to Sennacherib but decide to resist forthwith? With regard to either king, his actions *after* segment A are incongruous with the behavior that has been displayed *in* segment A. Furthermore, the account from verse 17 forward makes no reference whatsoever to Hezekiah's capitulation, and proceeds as if the events of segment A were never recounted.²⁵⁶ This is odd, considering the pivotal role of the tribute and its sheer size. The abrupt and problematic transitions, therefore, on either side of segment A probably signal redactional seams. Although it may be possible to conclude that this passage is an *addition* from an entirely different hand, the source citation at 2 Kgs 20:20 seems to indicate that this passage was incorporated into the text from the very beginning, that is, if it is truly derived from the state annals, as many have argued.

I contend that 2 Kgs 13b-16 was deliberately moved to its current position from another location within Kings itself. The motivations for the repositioning of the segment will be addressed hereafter. However, if A's present position is secondary, then its omission should reveal the original sequence of the narrative. The text would have read: "In the fourteenth year of King Hezekiah, the king of Assyria sent the viceroy, the chief eunuch, and the chief attendant from Lachish to King Hezekiah with a large military force to Jerusalem..." verse 13a leading directly into verse 17.²⁵⁷

²⁵⁵ Hull, 220-3.

²⁵⁶ Childs, 73.

²⁵⁷ Gonçalves' remark (359) that verse 13a could not have been connected to 17ff, because prophetic narratives never contain introductions with such precise dating, is simply not true. The account of 2 Kgs 22:3ff, which describes Josiah seeking an oracle from the prophetess Huldah after the book of the law was found in the Temple is one example. In fact, the order of the elements in the date formula at 2 Kgs 22:3 is the same as at 2 Kgs 18:13. (For other examples of precisely dated prophetic narratives written in the third person, see Jer 28:1ff, 32:1ff, and 36:9ff.)

At first glance, it would seem that no chronological difficulties are solved by the removal of segment A. However, difficulties remain only if we assume that the account beginning with verse 17 refers to events having to do with Sennacherib's invasion. As we shall see, this may not be the case.

Before I discuss the significance of my last statement, we must first determine if any other part of Chapters 18 and 19 is not original to the Sennacherib story. The remainder of the narrative, often called segment B (18:17-19:37), presents certain difficulties of its own. It has been suggested, and widely accepted, that segment B contains two separate stories. Strand B₁ recounts the appearance of three Assyrian officials at Jerusalem's gates who threaten King Hezekiah. The king turns to Isaiah, who predicts the withdrawal of the Assyrians, and the prophecy comes true when they pull away from Lachish (19:8). In strand B₂, Sennacherib sends a threatening letter to Hezekiah, who prays for assistance and receives a reassuring prophecy from Isaiah. The story concludes with the miracle of the angel of God slaying 185,000 of the Assyrian army. There are several convincing reasons for dividing the account in such a way:

1) It is difficult to understand how Sennacherib could have expected his letter(s) to frighten the Judahites into surrendering Jerusalem (19:9, 14), when his personal ambassadors had already failed to do so by means of a display of force (18:17, 18), especially when the message of the second threat is merely a repetition of the first.²⁵⁸

²⁵⁸ K. A. D. Smelik's argument that the letter was a logical follow-up to the visit of the Rabshakeh is weak ("Distortion of Old Testament Prophecy: The Purpose of Isaiah XXXVI and XXXVII," in *Crises and Perspectives: Studies in Ancient Near Eastern Polytheism, Biblical Theology, Palestinian Archaeology and Intertestamental Literature* [Oudtestamentische Studiën 24; Leiden: E. J. Brill, 1986] 81). He would have us believe that the letter was "the culmination of Sennacherib's arguments and blasphemy," asserting that "a letter has to convince where spoken words have failed." Even if we were willing to accept the logic of this statement, he simply fails to take into account that the earlier threat was backed by a show of military

2) Why would Hezekiah pray for Yahweh to turn his attention to the situation and save Jerusalem (19:15-19) after Isaiah had already promised him that Yahweh would not allow Jerusalem to be taken, and that the king of Assyria would withdraw to his own land and die there (19:6, 7)? Similarly, Isaiah's prophecy at 19:20-34 is presented as if this were the first time he has provided a reassuring oracle to Hezekiah concerning Sennacherib.

3) At 19:32-33, the prophet assures Hezekiah that the king of Assyria will not lay siege to the city, the imperfect verb forms indicating that the Assyrians had not yet done so. This seems odd, considering that the king had "sent a heavy military force to Jerusalem" immediately prior to this (18:17).²⁵⁹ That the Assyrians are actually laying siege to the city in Chapter 18 is supported by iconographic evidence that suggests that the actions of the Rabshakeh as described in 2 Kings reflect a part of Assyrian siege method.²⁶⁰

A fourth argument used to support the division of segment B, and the most predominant among scholars, calls attention to the similarity in the sequence of events outlined in the two accounts. Both begin with a demand for surrender by Assyrian messengers, and the threats are strikingly similar in both of the narratives. In each account, Hezekiah seeks divine assistance, and Isaiah provides him with a prophecy of

strength, whereas the later, written threat was not. The approach of Kushite forces would have further reduced the intimidating effect of the letter.

²⁵⁹ Laato, "Hezekiah," 63.

²⁶⁰ In *The Art of Warfare in Biblical Lands*, Yidael Yadin calls attention to this interesting artifact: "There has been preserved a unique relief from the reign of Sargon... which, in my opinion, depicts an Assyrian officer taking cover behind the turret of a battering ram... and apparently reading from something that looks like a scroll. It may be, perhaps, that he is reading a surrender order to the defending inhabitants on the walls" (Yadin, *The Art of Warfare in Biblical Lands in the Light of Archaeological Study* [Trans. M. Pearlman; New York: McGraw-Hill, 1963] 320, 424-5).

hope, which is in turn fulfilled. This has led many to conclude that each strand is merely a different version of the same tale.

Although there are grounds for separating the section into two accounts, the idea of *parallel* narratives cannot be sustained. To my knowledge, the only time we find parallel adjacent accounts in the Hebrew Bible is when a redactor joins two *preexisting* works that he either is not at liberty to cut or that he finds impractical to do so. Usually the stories are of two different genres (prose and poetry), such as we find at Exodus 14-15 and Judges 4-5. Those with greater editorial freedom make an effort to blend various accounts into a flowing narrative, as we know the Deuteronomistic Historian has consistently done elsewhere. Both B₁ and B₂ exhibit evidence of Deuteronomistic editing. For example, we can be fairly confident that the second account was put into the history by the Deuteronomistic Historian, since we find typical Deuteronomic phraseology in Hezekiah's prayer (19:15-19).²⁶¹ There are also indications that he had a hand in the first story, not only because there are Deuteronomic themes present,²⁶² but because there are elements in B₁ that anticipate elements in B₂.²⁶³ It does not seem reasonable to conclude that he would add a second version of the same story immediately after the original one without expecting readers to conclude that the latter piece described events that happened *after* the first story.²⁶⁴

²⁶¹ For example, אַתָּה הוּא הָאֱלֹהִים לְבַדּוֹךָ לְכָל מַמְלָכוֹת הָאָרֶץ (“You alone are the God for all the kingdoms of the earth”), cf. Deut 4:35, and מַעֲשֵׂה יָדֵי אָדָם עֵץ וָאֶבֶן (“human handicraft, wood and stone”), Deut 4:28. See M. Weinfeld, *Deuteronomy and the Deuteronomistic School* (London: Oxford University Press, 1972) 39.

²⁶² See the article by Ehud Ben Zvi, “Who Wrote the Speech of Rabshakeh and When?” (*Journal of Biblical Literature* 109/1 [1990] 79-92) especially 85-86, 88.

²⁶³ For example, 18:27, 31 appear to anticipate 19:29, and 18:35 appears to anticipate 19:18. (See Gallagher, 159.)

²⁶⁴ There is always the possibility that the Deuteronomistic Historian, drawing from two separate sources, did not realize that both accounts described the same events, but this could only be true if one of the sources was so damaged that its setting was unclear and if the Historian himself was a bit naïve.

The similarities between the two accounts of Assyrian invasion are only superficial. The Rabshakeh, the central figure of the first account, does not figure in the second whatsoever. Eliakim, Shebna, and Joah, who participate in the dialogue in the first section, are not even mentioned in the second. Isaiah, who is featured prominently in B₂, has only a minor role in B₁. While in B₁ Egypt is said to be Judah's ally, B₂ speaks of Kush.²⁶⁵ The content of each of Isaiah's messages has some noteworthy differences as well. Although both predict the withdrawal of Assyrian forces, the prophecy in B₂ makes no mention of the king of Assyria returning to his homeland after hearing a report of trouble and then being killed there. A further significant variance, which seems odd if both stories are relating the details of the same event, is that Assyrian forces actually come to Jerusalem in B₁, but not in B₂. In fact, B₂ states that a siege will not take place. Another striking difference is that only B₂ recounts the dramatic finale of the angel slaying 185,000 Assyrian soldiers. There is nothing even remotely parallel to this in B₁. The most interesting difference in the players of each drama has to do with the king of Assyria himself. Strand B₁ mentions the Assyrian monarch 10 times, but only as מלך אשור "the king of Assyria" (18:17, 19, 23, 28, 30, 31, 33; 19:4, 6, 8). Not once is a name provided.²⁶⁶ Strand B₂, on the other hand calls the king "Sennacherib" three out of the four times he is mentioned (19:16, 20, 36). It is therefore possible that Sennacherib does not feature at all in the first account. There is, admittedly, an unmistakable parallel

²⁶⁵ Although many historians have argued that these two place-names are almost synonymous, it must be acknowledged that the Assyrian sources differentiate between the two (A. Spalinger, "The Year 712 B.C. and its Implications for Egyptian History," *JARCE* 10 [1973] 100), and so we should be careful to avoid generalizations. Historically, it was during Hezekiah's reign that Kush gained ascendancy over Egypt (712 B.C.E.) (Spalinger, 95-101), and therefore the second story may reflect events from a later period than does the first.

between the Rabshakeh's speech in B₁ and Sennacherib's letter in B₂ (cf. 18:33, 34 with 19:12, 13),²⁶⁷ but in all probability the reason for the correspondence between the Assyrian speeches in each strand is not because both stories go back to a common source, but because both were composed by the same hand. The notion that strands B₁ and B₂ are variants of the same tradition will therefore be rejected in favor of a theory that each strand recounts an independent and distinct series of events and that the second series of events did not ensue immediately after the first.

C. Sargon and Hezekiah

If we accept the datum that Samaria was conquered in Hezekiah's sixth year, then it naturally follows that his fourteenth year would fall within the reign of Assyrian king Sargon II, rather than that of Sennacherib. As 2 Kgs 18:13a may introduce the account recorded in segment B₁, and as that segment allows for the participation of someone other than Sennacherib as the king of Assyria, it requires no forced understanding of the text to imagine Sargon as that king.²⁶⁸

Extrabiblical evidence adds weight to this hypothesis. For example, Sargon's army did, in fact, campaign into the Levant in his tenth regnal year (712 B.C.E.). There is every indication that this year coincided with the fourteenth year of King Hezekiah.

²⁶⁶ This was noted by A. K. Jenkins ("Hezekiah's Fourteenth Year: A New Interpretation of 2 Kings xviii 13-xix 37," *Vetus Testamentum* 26 [1976] 287). Chapter 20, verse 6 also neglects to name the king.

²⁶⁷ For a fuller discussion of this issue, see Gallagher, 153-59.

²⁶⁸ This observation is not new. However, previous attempts to equate the narrative with Sargon have proven unconvincing. For example, Jenkins, accepting the theory of parallel narratives, relates *both* B₁ and B₂ to Sargon, arguing that all references to Sennacherib in B₂ are a later editor's reinterpretation of the text. C. Schedl goes one step further and associates 2 Kgs 18:13-16 with Sargon's campaign to Judah following Ashdod's revolt, which fails to account for the passage's similarity with Sennacherib's annals ("Textkritische Bemerkungen zu den Synchronismen der Könige von Israel und Juda," *Vetus Testamentum*

Gershon Galil has persuasively argued in favor of dating the fall of Samaria to 720 B.C.E., Sargon's second year and Hezekiah's sixth.²⁶⁹ He bases his argument on several factors: 1) in the Babylonian Chronicle, the Samaria ravaged by Shalmaneser V could be the entire Northern Kingdom of Israel rather than the city itself, 2) the biblical text, although connecting Shalmaneser to the events associated with the conquest of Samaria, does not explicitly state that he was the king who conquered it, and 3) the numerous testimonies to Samaria's overthrow in the time of Sargon cannot be ignored and all assumed false. By Galil's dating, Sargon's military endeavor on Judah's doorstep in 712 matches Hezekiah's fourteenth year precisely.

According to Sargon's annalistic and display inscriptions, it was necessary at this time to put down a revolt in the Philistine city of Ashdod led by a certain Yamani. The earliest is Nineveh Prism A, Fragment D.²⁷⁰ The account breaks off during the description of the Ashdod campaign, and it is impossible to tell how much farther the text went on. In English, the text reads as follows:

[But these] accursed [Hittites] conceived [the idea] of not delivering the tribute and [started] a rebellion against their ruler; they expelled him ... Yamani, a comm[oner without claim to the throne] to be king over them, they made sit down [on the very throne] of his (former) master and [they prepared?] their city for the at[tack] (lacuna of 3 lines) ... its neighborhood, a moat [they prepared] of a depth of 20+ cubits ... it even reached the underground waters. In order to [... To] the rulers of Philistia, Judah, Ed[om], Moab, (and) those who live by the sea and bring tribute [and] *tamartu* gifts to my Lord Aššur [he spread] countless evil lies to alienate (them) from me, and sent bribes to Pharaoh the king of Egypt, a prince incapable of saving them, and asked him to be an ally. But I, Sargon, the rightful ruler, devoted to the pronouncements of Nebo and

12 [1962] 88-119). The theory presented here does not necessitate the rejection of the name Sennacherib in the narratives.

²⁶⁹ Galil, *Chronology*, 83-97.

²⁷⁰ Original publication by H. Winckler, *Die Keilschrifttexte Sargons I* (Leipzig: Eduard Pfeiffer, 1889) 186-89.

Marduk, who observes the orders of Aššur, led my army over the Tigris and Euphrates, at the[ir] highest water level, the spring high water, as (if it were) dry ground. This Yamani, their king who had put his trust in his own power and who did not bow to my rule, heard about the approach of my expedition (yet) far away, and the terror of my Lord Aššur overwhelmed him and ... of the bank of the river ... in the depth of the waters ... distant ... fled ... Ashdod ... I took [the road]. The city of ... against ... in the midst ... as ... the city of Lu... the city of ... against the land of ... the city of ... the land of Egypt ... his stones ... over the people
²⁷¹
 ...

Sargon claims that Judah received an invitation to join Yamani's anti-Assyrian coalition.

Whether or not Yamani was temporarily successful in alienating the states here

mentioned from Assyria is not stated, but the biblical text testifies that Hezekiah rebelled

against his Assyrian overlords.²⁷² If this was the context of Judah's rebellion, Sargon

may very well have responded with a show of military strength. The text breaks off just

as it is getting interesting. It would appear that several cities were engaged by Assyrian

forces, but only Ashdod's name is preserved. Another ("Lu...") is partially preserved.

Parallel sources mention also Gath and Ashdod-Yam.²⁷³

²⁷¹ Translation taken eclectically from Pritchard, *ANET* and Luckenbill, *ARAB*.

²⁷² 2 Kgs 18:7. For a full discussion of the evidence, see P. K. Hooker, *The Kingdom of Hezekiah: Judah in the Geo-Political Context of the Late Eighth Century BCE* (Ph.D. diss., Emory University, 1993) 18-32.

²⁷³ The other inscriptions describing the Ashdod campaign shed no more light on whether Judah was involved. The Display Inscription on the walls of the Khorsabad palace (first published in Winckler, *Die Keilschrifttexte Sargons I*, 115-16) reads: "But the[se] Hittites, always planning evil deeds, hated his (their former ruler Ahimiti's) reign and elevated to rule over them Yamani who, without any claim to the throne, had no respect for authority, just as they themselves (did not). In a sudden rage, I did not assemble the full might of my army (or to) prepare the camp(ing equipment), (only) my warriors who, even in friendly areas, never leave my side. But this Yamani heard about the approach of my expedition (yet) far away, and he fled into the territory of Egypt that belongs to Kush; and his (hiding) place could not be detected. I besieged (and) conquered the cities of Ashdod, Gath, Ashdod-Yam; I declared his images, his wife, his children, all his possessions and treasure of his palace, as well as the inhabitants of his country, as booty." (Translation taken eclectically from Pritchard, *ANET* and Luckenbill, *ARAB*). We are informed that Gath and Ashdod-Yam, both Philistine cities, are among the conquests of Sargon, but Judah is not mentioned. The Khorsabad Annals (II, 21 and H1, lines 249-61, originally published in A. G. Lie, *The Inscriptions of Sargon II, King of Assyria* [Paris: Librairie Orientaliste Paul Guether, 1929] 38-41) also mention the campaign, and their description is very similar to the Display Inscription: "But the[se] Hittites, always planning evil deeds, hated his (Ahimiti's) reign and elevated to rule over them Yamani who, without any claim to the throne, had no respect for authority, just as they themselves (did not). [In a sudden rage], I marched quickly in my state chariot and with my cavalry which, even in friendly areas, never leaves my side against Ashdod, his

From the pertinent inscriptions, we are able to ascertain a general order of events relating to the campaign:

- a) The Philistines of Ashdod (“accursed Hittites”) depose and expel Sargon’s vassal king Ahimiti and elevate Yamani as king in his place.
- b) The Ashdodites begin preparations for invasion, including the digging of a moat and the sending of conspiratorial messages to neighboring kingdoms (Judah, Edom, Moab, and other Philistine cities), and a payment to Egypt for military assistance.
- c) Sargon and his personal guard cross the Tigris and Euphrates (spring time) and approach Ashdod.
- d) Yamani goes to Kush, leaving his family behind.
- e) Sargon besieges and conquers Ashdod, Gath, and Ashdod-Yam.
- f) Other cities, the names of which are not preserved, are apparently conquered or attacked.²⁷⁴

Did Judah actually have a military encounter with Assyria at this time? We do have epigraphic evidence to support this conclusion. The text commonly known as the Azekah inscription describes the siege of the fortified city of Azekah in Judah by Assyrian forces. It consists of two fragments (BM 82-3-23, 131 and K 6205), originally

royal residence. I besieged (and) conquered the cities of Ashdod, Gath, Ashdod-Yam; I declared the gods residing therein, himself, as well as the inhabitants of his country, the gold, silver, and his personal possessions as booty.” (Translation taken eclectically from Pritchard, *ANET* and Luckenbill, *ARAB*). Again, no mention is made of Judah.

²⁷⁴ Interestingly, a recent study offers evidence that sites destroyed in eighth century southwestern Judah, often attributed to Sennacherib’s campaign of 701, should be associated with a slightly earlier Assyrian campaign into that area (J. A. Blakely and J. W. Hardin, “Southwestern Judah in the Late Eighth Century BCE,” *BASOR* 326 [2002] 11-64).

published separately;²⁷⁵ but in 1974, Nadav Na'aman discovered the join and made a preliminary analysis.²⁷⁶ Na'aman dated the inscription to Sennacherib's 701 campaign against Judah; however, his position has been called into question recently by several scholars who prefer to date the events described in the text to Sargon's campaign of 712.²⁷⁷ Their reasons are as follows: 1) The inscription locates Azekah "between my border and the land of Judah" (line 5). Since the Assyrians turned Ashdod and its environs into a province as a result of the 712 campaign and since Sennacherib's Annals refer to Ashdod as a vassal kingdom as a result of the 701 campaign, the inscription must have been composed between 712 and 701. Furthermore, there is no evidence for any Assyrian campaign against Philistia in this period. Therefore, the events described must refer to Assyria's last venture into the territory. 2) The literary style of the inscription is closely akin to Sargon's epic description of his campaign against Urartu, the last major campaign Sargon undertook before the Ashdod affair. 3) The composer spells the deity name "Anšar," rather than "Aššur," which is typical of many of Sargon's early inscriptions. For these reasons, the inscription is best dated to the time of Sargon. An English translation of the text reads as follows:

- (1)
- (2)
- (3) ... and to Ju[dah I approached]. In the course of my campaign, [I received] the tribute of the ki[ng/kings of ...]

²⁷⁵ K 6205 originally published by Rawlinson and Smith in *Cuneiform Inscriptions* III 9, 2; BM 82-3-23, 131 first appeared in Winckler, *Altorientalische Forschungen* II (Leipzig: Eduard Pfeiffer, 1898) pp. 570-74.

²⁷⁶ N. Na'aman, "Sennacherib's 'Letter to God' on his Campaign to Judah," *BASOR* 214 (1974) 25-39.

²⁷⁷ Hooker, 32-38; Gershon Galil, "Judah and Assyria in the Sargonid Period," *Zion* 57 (1992) 111-33 (Hebrew), "A New Look at the 'Azekah Inscription'," *RB* 102 (1995) 327-28; J. Goldberg, "Two Assyrian Campaigns Against Hezekiah and Later Eighth Century Biblical Chronology," *Biblica* 80 (1999) 363, esp. n. 10.

- (4) [with the power and mi]ght of Anšar, my lord, [I overwhelmed] the district of [Hezek]iah of Judah. L[ike a hurricane]
- (5) ... Azekah, his stronghold, which is located between my [la]nd and the land of Judah ...
- (6) [...] it is located on a mountain ridge, like pointed daggers without number reaching high to the heaven ...
- (7) [its walls] were strong and rivaled the highest mountains, to the (mere) sight, as if from the sky [appears its head ...]
- (8) [I besieged (this city) by means of beaten (earth) ra]mps, (by) great? battering rams brought near (its walls), (and with) the attack by foot soldiers ...
- (9) ... they had seen [the ... of my cav]alry, and they had heard the roar of the mighty troops of the god Anšar and [their hea]rts became afraid ...
- (10) I captured [this stronghold], I carried off its spoil, I destroyed, I devastated, [I burned with fire]
- (11) [I approached Ekron], a royal ci[ty] of the Philistines, which [Hezek]iah had captured and strengthened for himself ...
- (12) ... like a vine (planted) [on a peak of a mountain]
- (13) ... it was surrounded with mighty towers and [its ascent] was very sloping ...
- (14) ... a palace? (huge) like a mountain was barred in front of them and high is [its top ...]
- (15) [its ascent] was dark and the sun never shone on it; its waters were situated in darkness and [its?] overflow ...
- (16) ... it was cut with axes, and a moat was dug around it(s walls) ...
- (17) (his) skillful in battle warriors he caused to enter into it; his weapon he bound (on him) ...
- (18) ... all the units of Amurru; I caused them to carry earth ...
- (19) ... against them. In the seventh time, its mighty ... [I smashed] like a pot [of clay ...]
- (20) [... shee]p I carried out from it, [and counted as] spo[il] ...
- (21)²⁷⁸

The Azekah inscription confirms that Sargon not only settled matters in Ashdod and other Philistine cities, but also punished Judah for its support of Yamani's rebellion. At the very least, the Assyrians besieged Azekah and (apparently) conquered it. There is mention of the siege and conquest of another city. Though unnamed, it is identified as a

²⁷⁸ The translation is Galil's ("New Look," 323-24).

former Philistine city that Hezekiah had recently taken over. Galil makes a good case for identifying the city as Ebron.²⁷⁹

A passage in the Book of Isaiah clearly relates to the time of Sargon's attack on Philistia:

¹In the year that the viceroy came to Ashdod, when Sargon the king of Assyria sent him, he fought against Ashdod and captured it.²⁸⁰ ²At that time, Yahweh spoke by means of Isaiah the son of Amoz, saying, "Go, and loosen the sackcloth from around your waist and take your sandals off your feet." And he did so, walking around naked and barefoot. ³Then Yahweh said, "Just as my servant Isaiah walked naked and barefoot (three years there was a sign and an omen concerning Egypt and Kush),²⁸¹ ⁴so shall the king of Assyria lead the captives of Egypt and the exiles of Kush, young and old, naked and barefoot and with buttocks stripped, [from] the nakedness of Egypt. ⁵And they will be terrified and ashamed of Kush their hope and of Egypt their pride. ⁶And the inhabitants of this coastland will say on that day, 'So this was our hope to which we fled for assistance to be delivered from the face of the king of Assyria. Now how shall we escape?'" (Isa 20:1-6)

²⁷⁹ Galil, "Judah and Assyria," 111-33.

²⁸⁰ Many find the grammatical structure of verses 1-3 awkward, chiefly because verse 1 seems to be left hanging and does not appear to continue until verse 3. The most common explanation is that verse 2 is a later addition, or at least a parenthetical statement. To support such an interpretation, some have argued that God's command to Isaiah must have preceded the assault on Ashdod because the explanation of the three-year sign had to have been given at the end of the prophetic activity and when the Philistines were still hoping Egypt would come to their aid (cf. v. 6). Therefore the **בַּעַת הַהֵיאָ** ("at that time") of verse 2 cannot refer specifically to the event mentioned in verse 1 but to a time at least fourteen months prior (O. Kaiser, *Isaiah 13-39: A Commentary* [Philadelphia: Westminster Press, 1974] 113-14; J. N. Oswalt, *The Book of Isaiah: Chapters 1-39* [Grand Rapids: Eerdmans, 1986], 384; J. H. Hayes and S. A. Irvine, *Isaiah the Eighth Century Prophet: His Times and His Preaching* [Nashville: Abingdon Press, 1987] 270-71). However, verse 2 probably is original to the story because sign-act prophecies follow the pattern: a) command, b) execution, c) interpretation. The command cannot constitute a later addition (H. Wildberger, *Isaiah 13-27: A Continental Commentary* [Minneapolis: Fortress Press, 1997] 286-87; cf. Jer 13:1ff). Recognizing this, others have suggested that verse 1 is an addition and that the original context of verse 2 is lacking (Wildberger, 287). I do not think such a view is necessary. Grammatically, we may understand verse 1 as a complete sentence, with a preterital prefix verb introducing the apodosis. My translation reflects this interpretation. Naturally, this would indicate that God commissions Isaiah to perform the sign the same year that he explains it.

²⁸¹ Most commentators consider the three years to be the period that Isaiah walked naked and barefoot; however, the final part of verse 3 can be understood as a parenthetical statement and translated as a verbless clause. The three years would indicate the period in which the prophet had been giving signs and omens against an Egyptian alliance, but not necessarily the time he walked naked and barefoot. The three year figure aids us in determining the time that Yamani's rebellion began. An approximate date of 714 is indicated here.

This prophecy may be about the “inhabitants of this coastland,” i.e., the Philistines, but it is surely directed toward a Judahite audience. Isaiah’s own people would see his signs, and they would be the ones interested in them. The implication is that the Philistine appeal to Egypt was a topic of concern in Judah, no doubt because the Judahites too feared reprisal from the Assyrians. Judah also entertained hopes of Egyptian protection because they were among the rebels. That Isaiah had been speaking out against a Judahite-Egyptian alliance is clear from prophecies in the book bearing his name (cf. Isa 30:1ff, 31:1ff). It is therefore likely that Ashdod and Judah were united against Assyria at this time. That Isaiah was already wearing sackcloth before he was asked to remove it is an indication that he had been in mourning for some period of time.²⁸² Such attire may have been prophetic of what he thought would result from the alliance, namely the destruction of Judahite cities and the death of many of their inhabitants.

An examination of the Rabshakeh’s taunts in a Sargonic context proves rather interesting. He calls to Judah’s attention how certain other states have fallen to the might of Assyria (2 Kgs 18:33-35). He specifically mentions Arpad, Hamath, Sepharvaim, Hena, Ivvah, and Samaria. It may be no coincidence that Sargon, in his annals, boasts of putting down a rebellious coalition from Arpad, Hamath, and Samaria in the second year of his reign. The Rabshakeh’s reference to this could not have been more apropos, as now Judah is taking refuge in a similar coalition, and the fate of Samaria and her allies is still fresh in mind.²⁸³ Sepharvaim, Hena, and Ivvah were probably located in eastern

²⁸² J. Blenkinsopp, *Isaiah 1-39* (Anchor Bible 19; New York: Doubleday, 2000) 323.

²⁸³ See Chaim Cohen, “Neo-Assyrian Elements in the First Speech of the Biblical Rab-šaḳê,” *Israel Oriental Studies* 9 (1979) 36-8.

Babylonia²⁸⁴ and would have been conquered by Sargon when he campaigned against Marduk-apla-iddina. However, it is especially interesting that in B₂ *Sennacherib* makes similar statements (2 Kgs 19:12, 13), but remarks that Arpad, Hamath, Samaria, Sepharvaim, Hena, and Ivvah are among the lands “that *my forefathers* brought to ruin.” In strand B₁, the king of Assyria gives due credit, not to his ancestors, but to himself: “Where are the gods of Hamath and Arpad?... Have any delivered Samaria out of *my* hand?”

The reference to the appearance of Sargon’s viceroy (Hebrew *tartān*; Akkadian *turtanu*) at Jerusalem’s gates at 2 Kgs 18:17 is historically possible, because we know that he was in the Levant during the campaign in 712 (Isa 20:1). Thus the *tartān* mentioned in Kings and in Isaiah may be one and the same person.

One must acknowledge, however, that in the Kings account, the king of Assyria is said to be personally involved in the campaign, while in the eponym chronicle for that year, Sargon is reported as staying home. This would seem to be supported by Isa 20:1, which describes the *turtanu*, rather than Sargon, leading the assault on Ashdod. However, in his annals, Sargon depicts himself as personally leading the campaign into the Levant. Likewise, in the Azekah inscription, the king also maintains that he is involved in the siege. Although we can easily dismiss his claims as self-aggrandizement, we should at least consider the possibility that Sargon participated in the campaign.

Where does strand B₁ end? The account would logically conclude with the king fighting against the Philistine city of Libnah (19:8) but would not include the reference to

²⁸⁴ Na’aman, “New Light on Hezekiah’s Second Prophetic Story,” *Biblica* 81 (2000) 394-5.

Tirhakah (mentioned in the next verse), as he would not have been alive at that time.²⁸⁵

Although Sennacherib is credited with capturing Lachish, it is not anachronistic to find Sargon there in 712. He too may have attempted to take the city – perhaps with success, perhaps not.

The reference to Sennacherib's death in 2 Kgs 19:37 has usually been taken as the fulfillment of Isaiah's prophecy in 19:6-7 that the Assyrian king would fall by the sword in his own country. However, the phrase "fall by the sword" (נפל בחרב) in the Bible refers to casualties of war, not to assassination (cf. Lev 26:7-8; Num 14:43; 2 Sam 1:12; Ezek 11:9-10). As Sargon was killed in battle in 705 B.C.E. near the eastern Assyrian border, this prophecy applies more fittingly to him.

D. Sennacherib and Hezekiah

The second tale, strand B₂, begins with the statement, "When he heard it said about Tirhakah, the king of Kush, 'He is now coming out to fight against you,' he sent messengers again to Hezekiah..." (2 Kgs 19:9). The "he" referred to is no longer Sargon, but Sennacherib. However, one must note that the pronoun "he" has no antecedent, and the word וישב indicates a previous correspondence between Sennacherib and Hezekiah. B₂, therefore, would seem to require a proper opening. As Antii Laato has pointed out, the narrative beginning with Tirhakah's advance "presupposes some kind of introduction, for which purpose Tirhakah's planned campaign is eminently suitable."²⁸⁶ However, the

²⁸⁵ The historicity of Tirhakah's involvement in the second account is substantiated by Kenneth Kitchen in *The Third Intermediate Period in Egypt (1100-650 B.C.)* (Warminster: Aris & Phillips, 1973; 2nd ed. with supplement, 1986) 157-61.

²⁸⁶ Laato, "Hezekiah," 53.

opening need not be segment B₁. Surely the withdrawal of the Assyrian king to Libnah (19:8) constitutes the conclusion of an episode rather than an introduction. It is at this point that we should again take note of segment A. We have not, as of yet, determined its original context in Kings, and it is evident that it cannot stand on its own. Some continuation of A must be assumed, as it does not contain a conclusion. What was Sennacherib’s reaction after Hezekiah paid the tribute? Was the attack on Judah halted?²⁸⁷ In this case, the simplest solution works best: segment A is the most suitable prologue to B₂. This conclusion is supported by the remarkable affinity between B₂ and A. The usage of epithets for the kings corresponds to the suggested divisions:

Table B.1: Name Patterns in 2 Kings 18-19

A (18:13b-16)	B₁ (18:13a; 18:17-19:8)	B₂ (19:9-37)
Sennacherib, the king of Assyria (13b) Hezekiah, the king of Judah (14) Hezekiah, the king of Judah (14) Hezekiah (15) Hezekiah (16)	King Hezekiah (13a) King Hezekiah (17) Hezekiah (19) Hezekiah (22) Hezekiah (29) Hezekiah (30) Hezekiah (31) Hezekiah (32) Hezekiah (37) King Hezekiah (19:1) Hezekiah (3) King Hezekiah (5)	Tirhakah, the king of Kush (9) Hezekiah (9) Hezekiah, the king of Judah (10) Hezekiah (14) Hezekiah (14) Hezekiah (15) Sennacherib (16) Hezekiah (20) Sennacherib, the king of Assyria (20) Sennacherib, the king of Assyria (36)

Note: All references to kings in the text that are unaccompanied by a personal name are not listed in this table.

The formula “*x, the king of y*” is common in both A and B₂, but is not found in B₁.

Moreover, the title “*King Hezekiah*” is used in B₁, but not in either A or B₂. A personal name by itself is found in all three segments.

²⁸⁷ Laato, “Hezekiah,” 56-7.

I believe the manner in which the names are used is an indication that the Deuteronomistic Historian drew from two sources, one that described Sargon's campaign of 712 and one that recounted Sennacherib's invasion of 701. This interpretation is reinforced by the fact that segments A and B₂ both feature Sennacherib as the antagonist, whereas B₁ does not mention him at all. Furthermore, the sequence of events from A through B₂ flows smoothly and better fits the extrabiblical evidence for Sennacherib's invasion of Judah in the fourth year of his reign. Likewise, as we have seen, the account in B₁ best fits a historical context in the reign of Sargon.

If indeed segments A and B₂ were once connected as part of a separate narrative, and if the Deuteronomistic Historian was aware that each invasion story was distinct, then B₂, like A, was not in its present position in an early edition of the Deuteronomistic History. Without B₂, the story in B₁, set in Hezekiah's fourteenth year, leads neatly into chapter 20, which also recounts events of that very year. Hence, the narrative sequence may once have run as follows:

18:13a

18:17-19:8

20:1-19

These events all are set in Hezekiah's fourteenth year, and since the Babylonian king Merodach-baladan (Marduk-apla-iddina) mentioned in chapter 20 reigned from 721-710, there is further reason for accepting 712 B.C.E. as Hezekiah's fourteenth regnal year.

If all mentioned portions of the text were put into chronological order, segments A and B₂ would be positioned after 2 Kgs 20:19. Such an order would account for the apparent discrepancy of Isaiah predicting Hezekiah's deliverance (20:6) *after* the

deliverance is recounted (19:35). It would additionally explain how it happened that Hezekiah showed off his great treasures (20:13) *after* he had given them all away (18:15-16). It seems sensible to conclude that the Sennacherib story once followed upon the heels of the narratives found in chapter 20.

E. Who Reordered the Narrative, and When?

Ascertaining the person responsible for restructuring the Hezekiah narratives and the date of his editing is extremely difficult. First, we do not know whether Kings or Isaiah has priority. Most scholars assume that the Kings version came first. The important point is that *both* versions are out of order and agree in their disorder. There are several possible explanations for their commonality. The Kings version could have been taken directly from Isaiah after the text had already been rearranged, or the Isaiah version may have been drawn from Kings after Kings was rearranged. On the other hand, it is possible that both Kings and Isaiah were copied from a common source. However, if Kings were copied from Isaiah or if Kings and Isaiah share the same source, the original source would have had to have been rearranged prior to any copying. This would necessitate a very early date for the reorganized text. I am therefore inclined to give priority to Kings. Whatever the case, the layout of the reordering is simple and clear:

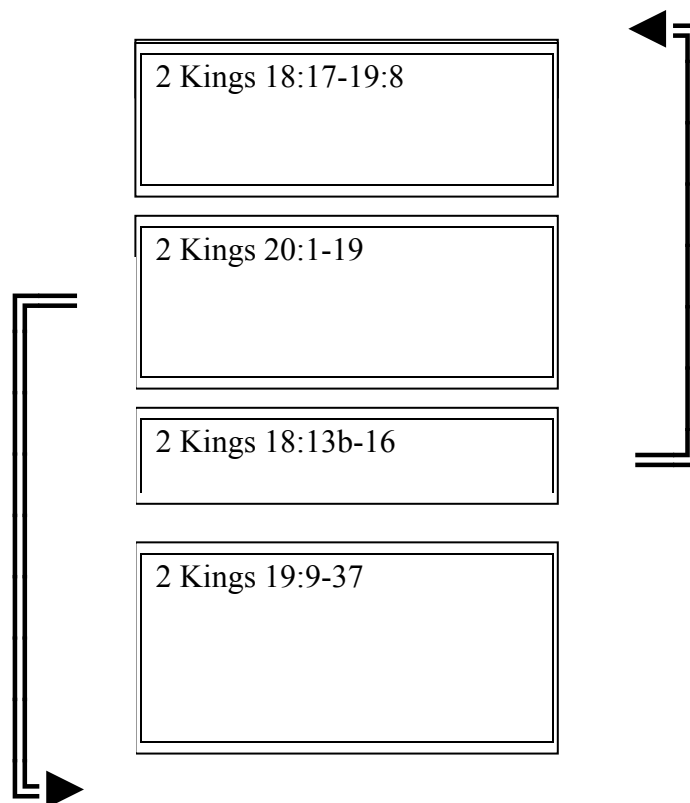

Figure B.1: The Reordering of 2 Kings 18-20

This sort of restructuring of a narrative sequence by ancient editors of texts is by no means uncommon and is usually done for thematic or ideological reasons, or simply to “correct” a text that is seen to be inaccurate or problematic.²⁸⁸

With all of the difficulties involved, I can only present a possible scenario: The Deuteronomistic History had the material in the proper sequence, but the Redactor of the Primary History (Genesis—2 Kings), perhaps under the influence of the Chronicler’s version of the story, altered the sequence. An editor of the Book of Isaiah copied the later version.

²⁸⁸ See D. A. Glatt, *Chronological Displacement in Biblical and Related Literatures* (SBL Dissertation Series 139; Atlanta: Scholars Press, 1993).

Other scenarios could also be conjectured. What seems certain, however, is that editorial activity in both 2 Kings 18-20 and Isaiah 36-39 has obscured an original story about a Sargonic invasion of Judah in 712 B.C.E. and created a historical misunderstanding that has lasted until today.

Bibliography

- Ackroyd, Peter R. "The Meaning of Hebrew dôr Considered." *Journal of Semitic Studies* 13.1 (1968): 3-10.
- Albrektson, B. *History and the Gods*. Lund: Gleerup, 1967.
- Albright, William Foxwell. "Abram the Hebrew: A New Archaeological Interpretation." *Bulletin of the American Schools of Oriental Research* 1.163 (1961): 36-54.
- . "The Gezer Calendar." *Bulletin of the American Schools of Oriental Research* 92 (1943): 16-26.
- André, G. "מָהָר." In *Theological Dictionary of the Old Testament*, edited by G. J. Botterweck et al., VIII: 237-41. Grand Rapids: Eerdmans, 1997.
- Auerbach, E. "Die babylonische Datierung im Pentateuch und das Alter des Priester-Kodex." *Vetus Testamentum* 2 (1952): 334-42.
- Barnes, William Hamilton. *Studies in the Chronology of the Divided Monarchy of Israel*. Edited by Frank Moore Cross. Atlanta: Scholars Press, 1991.
- Barthélemy, Dominique. *Les devanciers d'Aquila*. Vol. 10, *Supplements to Vetus Testamentum*. Leiden: Brill, 1963.
- Beckwith, Roger T. *Calendar and Chronology, Jewish and Christian*. Leiden: Brill, 1996.
- Bickerman, Elias J. *Chronology of the Ancient World*. Ithaca: Cornell University Press, 1968.
- Bin-Nun, Shoshana R. "Formulas from Royal Records of Israel and of Judah." *Vetus Testamentum* 18 (1968): 414-32.
- Boling, Robert G. "Some Conflate Readings in Joshua-Judges." *Vetus Testamentum* 16 (1966): 293-98.
- Borowski, Oded. *Agriculture in Iron Age Israel*. Ann Arbor: University of Michigan, 1979.
- Bottéro, Jean. *Mesopotamia: Writing, Reasoning, and the Gods*. Chicago: University of Chicago Press, 1992.

- Brin, Gershon. *The Concept of Time in the Bible and the Dead Sea Scrolls*. Edited by F. Garcia Martinez. Vol. 34, *Studies on the Texts of the Desert of Judah*. Leiden: Brill, 2001.
- Buis, P. "Rois." In *SDB 9*: cols. 695-750, 1982.
- Clagett, Marshall. *Ancient Egyptian Science*. 2 vols. Vol. II. Independence Square: American Philosophical Society, 1995.
- Clements, R. E. "ירח." In *Theological Dictionary of the Old Testament*, edited by G.J. Botterweck et al., VI: 355-62. Grand Rapids: Eerdmans, 1990.
- Clines, D.J.A. "The Evidence for an Autumnal New Year in Pre-exilic Israel Reconsidered." *Journal of Biblical Literature* 93.1 (1974): 22-40.
- Cogan, Mordechai. *1 Kings*. New York: Doubleday, 2001.
- . "Chronology, Hebrew Bible." In *Anchor Bible Dictionary*, edited by D.N. Freedman, I: 1002-11. New York: Doubleday, 1992.
- Cohen, Mark E. *The Cultic Calendars of the Ancient Near East*. Bethesda, Md.: CDL Press, 1993.
- Cortese, E. "Problemi attuali circa l'opera deuteronomistica." *Rivista biblica italiana* 26 (1978): 341-52.
- Cross, Frank Moore. *Canaanite Myth and Hebrew Epic*. Cambridge: Harvard University Press, 1973.
- . "A Fragment of a Monumental Inscription from the City of David." *Israel Exploration Journal* 51.1 (2001): 44-47.
- . "The Structure of the Deuteronomic History." In *Perspectives in Jewish Learning* 3: 9-24. Chicago, 1968.
- de Lagarde, Paul. *Ankündigung einer neuen Ausgabe der griechischen Übersetzung des alten Testaments*. Göttingen, 1882.
- Eliade, Mircea. *Cosmos and History: The Myth of the Eternal Return*. Translated by Willard K. Trask. New York: Harper & Row, 1959.
- Etz, D.V. "The Numbers of Genesis V 3-31: A Suggested Conversion and its Implications." *Vetus Testamentum* 43 (1993): 171-89.
- Finegan, Jack. *Handbook of Biblical Chronology*. 2nd ed. Peabody: Hendrickson, 1998.

- Forsdyke, John. *Greece Before Homer: Ancient Chronology and Mythology*. New York: W.W. Norton, 1964.
- Frankfort, Henri. *Kingship and the Gods*. Chicago: University of Chicago Press, 1948.
- Freedman, D.N. "The Babylonian Chronicle." *Biblical Archaeologist* 19 (1956): 50-60.
- . "Kingly Chronologies: Then and Later." In *Eretz-Israel XXIV, Avraham Malamat Volume: 41*-65**. Jerusalem: Israel Exploration Society, 1993.
- . "Pentateuch." In *Interpreter's Dictionary of the Bible*, III: 711-27, 1962.
- Freedman, D.N., and Jack R. Lundbom. "דָּוִד." In *Theological Dictionary of the Old Testament*, edited by G. Johannes Botterweck and Helmer Ringgren, III: 169-81. Grand Rapids: Eerdmans, 1978.
- Fried, Lisbeth S., and D.N. Freedman. "Was the Jubilee Year Observed in Preexilic Judah?" In *Leviticus 23-27: 2257-70*. New York: Doubleday, 2001.
- Friedman, Richard Elliott. *The Bible with Sources Revealed*. San Francisco: HarperSanFrancisco, 2003.
- . "The Deuteronomistic School." In *Fortunate the Eyes that See: Essays in Honor of David Noel Freedman in Celebration of his Seventieth Birthday*, edited by Astrid B. et al Beck: 70-80. Grand Rapids: Eerdmans, 1995.
- . *The Exile and Biblical Narrative: the Formation of the Deuteronomistic and Priestly Works*. Chico, Calif.: Scholars Press, 1981.
- . "From Egypt to Egypt: Dtr1 and Dtr2." In *Traditions in Transformation: Turning Points in Biblical Faith*, edited by B. Halpern and J. D. Levenson: 167-92. Winona Lake: Eisenbrauns, 1981.
- . *The Hidden Book in the Bible*. San Francisco: HarperSanFrancisco, 1998.
- . "Torah." In *Anchor Bible Dictionary*, edited by David Noel Freedman, VI: 605-22. New York: Doubleday, 1992.
- . *Who Wrote the Bible?* Englewood Cliffs, N.J.: Prentice Hall, 1987, 1997.
- Galil, Gershon. *The Chronology of the Kings of Israel and Judah, Studies in the history and culture of the ancient Near East v. 9*. Leiden; New York: E.J. Brill, 1996.

- Gandz, Solomon. "The Calendar of Ancient Israel." *Homenaje a Millás Vallicrosa I* (1954): 623-46.
- . "The Origin of the Planetary Week or the Planetary Week in Hebrew Literature." In *Proceedings of the American Academy for Jewish Research*, XVIII: 213-54, 1949.
- Geoghegan, Jeffrey C. *Until Whose Day? A Study of the Phrase "Until This Day" in the Deuteronomistic History, History*: Ph.D. Thesis, University of California, San Diego, 1999.
- Glanville, S.R.K. *The Legacy of Egypt*. London: Oxford, 1942.
- Glassner, Jean-Jacques. *Mesopotamian Chronicles*. Atlanta: Society of Biblical Literature, 2004.
- Gray, John. *I and II Kings*. 2nd ed, *OTL*. Philadelphia: SCM Press, 1970.
- Halpern, Baruch. *The Constitution of the Monarchy in Israel*. Chico, CA: Scholars Press, 1981.
- . *The First Historians: The Hebrew Bible and History*. San Francisco: Harper & Row, 1988.
- Halpern, Baruch, and David S. Vanderhooff. "The Editions of Kings in the 7th-6th Centuries B.C.E." *Hebrew Union College Annual* 62 (1991): 179-244.
- Haran, Menahem. "Behind the Scenes of History: Determining the Date of the Priestly Source." *Journal of Biblical Literature* 100.3 (1981): 321-33.
- . *Temples and Temple Service in Ancient Israel*. Oxford: Oxford University Press, 1978.
- Hayes, John H., and Paul K. Hooker. *A New Chronology for the Kings of Israel and Judah*. Atlanta: John Knox Press, 1988.
- Hendel, Ronald S. *The Text of Genesis 1-11: Textual Studies and Critical Edition*. New York: Oxford University Press, 1998.
- Hughes, Jeremy. *Secrets of the Times: Myth and History in Biblical Chronology*. Edited by D.J.A. Clines and P. R. Davies. Vol. 66, *Journal for the Study of the Old Testament Supplement Series*. Sheffield: JSOT Press, 1990.
- Hurvitz, Avi. "Dating the Priestly Source in Light of the Historical Study of Biblical Hebrew a Century after Wellhausen." *ZAW Supplement* (1988): 88-100.

- . "The Evidence of Language in Dating the Priestly Code." *Revue Biblique* 81 (1974): 24-56.
- . *A Linguistic Study of the Relationship Between the Priestly Source and the Book of Ezekiel*. Paris: Gabalda, 1982.
- Iwry, Samuel. "The Qumran Isaiah and the End of the Dial of Ahaz." *Bulletin of the American Schools of Oriental Research* 1.147 (1957): 27-33.
- Jacobsen, Thorkild. "Mesopotamian Gods and Pantheons." In *Toward the Image of Tammuz and Other Essays on Mesopotamian History and Culture*, edited by William L. Moran. Cambridge: Harvard University Press, 1970.
- Jenks, A. W. "Elohist." In *Anchor Bible Dictionary*, edited by David Noel Freedman, II: 478-82. New York: Doubleday, 1992.
- . *The Elohist and North Israelite Traditions, Society of Biblical Literature Monograph Series*. Missoula, MT: SBL, 1977.
- Kahle, Paul. *The Cairo Geniza*. 2 ed. Oxford, 1959.
- . "Die Septuaginta: Principielle Erwägungen." In *Festschrift Otto Eissfeldt*. Halle, 1947.
- . "Untersuchungen zur Geschichte des Pentateuchtextes." *Theologische Studien und Kritiken*. 88 (1915).
- Kitchen, Kenneth A. "The Historical Chronology of Ancient Egypt, A Current Assessment." In *The Synchronisation of Civilisations in the Eastern Mediterranean in the Second Millennium B.C.*, edited by Manfred Bietak: 39-52. Wien: Verlag der Österreichischen Akademie der Wissenschaften, 2000.
- Klein, R.W. "Archaic Chronologies and the Textual History of the Old Testament." *Harvard Theological Review* 67 (1974): 255-63.
- Kugler, F.X. *Von Moses bis Paulus: Forschungen zur Geschichte Israels*. Münster: Verlag der Aschendorffschen Verlagsbuchhandlung, 1922.
- Kutsch, E. "'am Ende des Jahres!': Zur Datierung des israelitischen Herbstfestes in Ex 23,16." *Zeitschrift für die alttestamentliche Wissenschaft* 83 (1971): 15-21.
- Larsson, Gerhard. "The Chronology of the Pentateuch: A Comparison of the MT and LXX." *Journal of Biblical Literature* 102.3 (1983): 401-09.

- Lemaire, A. "Vers L'histoire de la rédaction des livres des Rois." *ZAW* 98 (1986): 221-36.
- Lohfink, Norbert. *Rückblick im Zorn auf den Staat, Vorlesungen zu ausgewählten Schlüsseltexten der Bücher Samuel und Könige*. Frankfurt: Privatdruck, 1984.
- Lundbom, Jack R. *Jeremiah 1-20*. New York: Doubleday, 1999.
- . *Jeremiah 21-36*. New York: Doubleday, 2004.
- . "Jeremiah, Book of." In *Anchor Bible Dictionary*, edited by D.N. Freedman, III: 706-21. Garden City: Doubleday, 1992.
- . *Jeremiah: A Study in Ancient Hebrew Rhetoric*. 2nd ed. Winona Lake: Eisenbrauns, 1997.
- Macalister, Robert A.S. *The Excavation at Gezer*. 2 vols. Vol. II. London: Palestine Exploration Fund, 1912.
- Malalae, Ioannis. *Chronographia; ex recensione Ludovici Dindorfii*. Bonnae: impensis E. Weberi, 1831.
- Meyer, Eduard. "Herodots Chronologie der griechischen Sagengeschichte." In *Forschungen zur alten Geschichte*, I: 151-88. Halle: Niemeyer, 1892.
- . "Principien der rechnung nach Königsjahren." In *Forschungen zur alte Geschichte*, II: 440-53. Halle: Niemeyer, 1899.
- Miano, David. "The Twelve Sepharim of the Torah." *The Biblical Historian* 1.1 (2004): 10-19.
- Milgrom, Jacob. "The Antiquity of the Priestly Source." *ZAW* 111 (1999): 10-22.
- . *Leviticus 1-16, AB 3*. New York: Doubleday, 1991.
- . *Leviticus 23-27*. New York: Doubleday, 2001.
- Montgomery, James A. *A Critical and Exegetical Commentary on the Books of Kings*. Edited by Henry Snyder Gehman, ICC. New York: Charles Scribner's Sons, 1951.
- Morganstern, Julian. "Supplementary Studies in the Calendars of Ancient Israel." In *Hebrew Union College Annual*, X: 1-148, 1935.
- Mosshammer, Alden A. *The Chronicle of Eusebius and Greek Chronographic Tradition*. Lewisburg, Pa.: Bucknell University Press, 1979.

- , ed. *Georgii Syncelli: Ecloga Chronographica*. Leipzig: BSB B.G. Teubner Verlagsgesellschaft, 1984.
- Mowinckel, Sigmund. *Psalmenstudien*. 2 vols. Vol. 1. Amsterdam: P. Schippers, 1966.
- . *Zum israelitischen Neujahr und zur Deutung der Thronbesteigungspsalmen*. Oslo: Jacob Dybwad, 1952.
- Nelson, Richard D. *The Double Redaction of the Deuteronomistic History*. Sheffield: JSOT Press, 1981.
- Neuberg, Frank J. "An Unrecognized Meaning of Hebrew dôr." *Journal of Near Eastern Studies* 9.4 (1950): 215-17.
- Nicholson, Ernest. *The Pentateuch in the Twentieth Century*. Oxford: Clarendon Press, 1998.
- Niehr, H. "ערב." In *Theological Dictionary of the Old Testament*, edited by G.J. Botterweck et al., XI: 335-41. Grand Rapids: Eerdmans, 2001.
- North, F.S. "Four-Month Seasons of the Hebrew Bible." *Vetus Testamentum* 11.4 (1961): 446-48.
- North, J. L. "הדש." In *Theological Dictionary of the Old Testament*, edited by G.J. Botterweck et al., IV: 225-44. Grand Rapids: Eerdmans, 1977.
- Otto, Eckart. "שבט." In *Theological Dictionary of the Old Testament*, edited by G.J. Botterweck et al., XIV: 336-67. Grand Rapids: Eerdmans, 2005.
- Parker, Richard A. "The Beginning of the Lunar Month in Ancient Egypt." *Journal of Near Eastern Studies* 29.4 (1970): 217-20.
- . *The Calendars of Ancient Egypt, S.A.O.C. 26*. Chicago: University of Chicago Press, 1950.
- Parker, Richard A. and Waldo H. Dubberstein. *Babylonian Chronology, 626 B.C. - A.D. 75*. 3rd ed. Providence: Brown University Press, 1956.
- Polzin, Robert. *Late Biblical Hebrew: Toward an Historical Typology of Biblical Hebrew Prose*. Atlanta: Scholars Press, 1976.
- Prakken, Donald Wilson. *Studies in Greek Genealogical Chronology*. Lancaster, PA: Lancaster Press, 1943.
- Propp, William H. C. *Exodus 1-18*. New York: Doubleday, 1999.

- Rendsburg, Gary A. "Late Biblical Hebrew and the Date of P." *JANES* 12 (1980): 65-80.
- Richter, Wolfgang. *Die Bearbeitung des 'Richterbuches' in der deuteronomistischen Epoche*. Bonn: Peter Hanstein, 1964.
- . *Traditionsgeschichtliche Untersuchungen zum Richterbuch*. Bonn: Peter Hanstein, 1963.
- Roberts, J. J. M. "Mowinckel's Enthronement Festival: A Review." In *The Book of Psalms: Composition and Reception*, edited by Jr. P.W. Flint and PD. Miller: 97-115. Leiden: Brill, 2005.
- Rochberg-Halton, F. "Calendars, Ancient Near East." In *Anchor Bible Dictionary*, edited by D.N. Freedman, I. Garden City: Doubleday, 1992.
- Rochberg, Francesca. "Astronomy and Calendars in Ancient Mesopotamia." In *Civilizations of the Ancient Near East*, edited by Jack M. Sasson, III: 1925-40. Peabody: Hendricksons, 1995.
- Saggs, H. W. F. *The Greatness that was Babylon*. New York: Mentor, 1968.
- Samuel, Alan E. *Greek and Roman Chronology: Calendars and Years in Classical Antiquity*. München: Beck'sche Verlagsbuchhandlung, 1972.
- Schlauri, I. "W. Richters Beitrag zur Redaktionsgeschichte des Richterbuches." *Bib* 54 (1973): 367-403.
- Schwyzler, E., ed. *Dialectorum Graecarum Exempla Epigraphica Potiora*. Hildesheim: Georg Olms, 1960.
- Segal, J.B. "Intercalation and the Hebrew Calendar." *Vetus Testamentum* 7 (1957): 250-307.
- Seow, C. L. *Myth, Drama, and the Politics of David's Dance*. Atlanta: Scholars Press, 1989.
- Sethe, K. "Die Zeitrechnung der alten Ägypter im Verhältnis zu der der andern Völker." In *Nachrichten von der Königlichen Gesellschaft der Wissenschaften zu Göttingen, Philologisch-historische Klasse aus dem Jahre 1920*: 130-38. Berlin, 1920.
- Shenkel, James Donald. *Chronology and Recensional Development in the Greek Text of Kings*. Cambridge: Harvard University Press, 1968.

- Shortland, A. J. "Shishak, King of Egypt: The Challenges of Egyptian Calendrical Chronology." In *The Bible and Radiocarbon Dating*, edited by Thomas E. Levy and Thomas Higham: 43-54. London: Equinox, 2005.
- Smelik, K.A.D. *Saul, de voorstelling van Israëls eerste koning in de Masoretische tekst van het Oude Testament*. Dissertation, Amsterdam: P.E.T., 1977.
- Soggin, J. Alberto. *Judges: A Commentary*. Philadelphia: Westminster Press, 1981.
- Stern, Sacha. *Calendar and Community*. Oxford: Oxford University Press, 2001.
- Stroes, H. R. "Does the Day Begin in the Evening or Morning? Some Biblical Observations." *Vetus Testamentum* XVI (1966): 460-75.
- Tadmor, Hayim. "The Chronology of the First Temple Period: A Presentation and Evaluation of the Sources." In *Age of the Monarchies: Political History*, edited by Abraham Malamat and Israel Eph'al: 44-60, 318-20. Jerusalem: Massada Press, 1979.
- . *The Inscriptions of Tiglath-pileser III, King of Assyria*. Jerusalem: Israel Academy of Sciences and Humanities, 1994.
- Talmon, Shemaryahu. "»400 Jahre« oder »vier Generationen« (Gen 15,13-15): Geschichtliche Zeitangaben oder literarische Motive?" In *Die Hebräische Bibel und ihre zweifache Nachgeschichte*: 13-25: Neukirchener Verlag, 1990.
- . "The Gezer Calendar and the Seasonal Cycle of Ancient Canaan." In *King, Cult and Calendar in Ancient Israel*: 89-112. Jerusalem: Magnes Press, 1963.
- . "Whence the Day's Beginning in the Biblical Period and in the Beginning of the Second Temple Period?" In *The Bible as Reflected in its Commentators*, edited by S. Japhet: 109-29. Jerusalem: Magnes, 1994.
- Taylor, Jeremy Graeme. *Framing the Past: The Roots of Greek Chronography*: Ph.D. Thesis, University of Michigan, 2000.
- Tetley, M. Christine. *The Reconstructed Chronology of the Divided Kingdom*. Winona Lake: Eisenbrauns, 2005.
- Thiele, Edwin R. *The Mysterious Numbers of the Hebrew Kings*. Grand Rapids: Eerdmans, 1951, 1965, 1983.
- Tov, Emanuel. *Textual Criticism of the Hebrew Bible*. 2nd ed. Minneapolis: Augsburg Fortress, 2001.

- VanderKam, James C. "Calendars, Ancient Israelite and Early Jewish." In *Anchor Bible Dictionary*, edited by D.N. Freedman, I: 814-20. New York: Doubleday, 1992.
- . "Weeks, Feast of." In *Anchor Bible Dictionary VI*, edited by D.N. Freedman: 895-97. New York: Doubleday, 1992.
- Vaux, Roland de. *Ancient Israel: Its Life and Institutions*. London: Darton, Longman, and Todd, 1961.
- Verbrugghe, Gerald P., and John M. Wickersham. *Berosus and Manetho, Introduced and Translated*. Ann Arbor: University of Michigan Press, 1996.
- Wacholder, Ben Zion. "Biblical Chronology in the Hellenistic World Chronicles." *Harvard Theological Review* 61 (1968): 451-81.
- Wagenaar, Jan A. *Origin and Transformation of the Ancient Israelite Festival Calendar*. Wiesbaden: Harrassowitz Verlag, 2005.
- Weinfeld, Moshe. *Deuteronomy and the Deuteronomistic School*. Oxford: Oxford University Press, 1972.
- Weippert, H. "Die 'deuteronomistischen' Beurteilungen der Könige von Israel und Juda und das Problem der Redaktion der Königsbücher." *Bib* 53 (1972): 301-39.
- Weippert, M. "Fragen des israelitischen Geschichtsbewusstseins." *Vetus Testamentum* 23 (1973): 415-42.
- Williamson, H. G. M. "The Death of Josiah and the Continuing Development of the Deuteronomistic History." *Vetus Testamentum* 32 (1982): 242-47.
- Wilson, Robert R. *Genealogy and History in the Biblical World*. New Haven: Yale University Press, 1977.
- Wright, Richard M. *Linguistic Evidence for the Pre-exilic Date of the Yahwistic Source*. New York, NY: T & T Clark, 2005.
- Yadin, Yigael. "מעלות אהז." *Eretz Israel* 5 (1958): 91-96.
- Zevit, Ziony. "Converging Lines of Evidence Bearing on the Date of P." *ZAW* 94 (1982): 502-09.