

Thermodynamic origin of nonimaging optics

Lun Jiang,^a and Roland Winston,^{a*}

^a University of California, Merced

Abstract. Nonimaging Optics is the theory of thermodynamically efficient¹ optics and as such depends more on thermodynamics than on optics. Hence in this paper a condition for the "best" design is proposed based on purely thermodynamic arguments, which we believe has profound consequences for the designs of thermal and even photovoltaic systems. This new way of looking at the problem of efficient concentration depends on probabilities, the ingredients of entropy and information theory while "optics" in the conventional sense recedes into the background. Much of the paper is pedagogical and retrospective. Some of the new development of flowline designs will be introduced at the end and the connection between the thermodynamics and flowline design will be graphically presented. We will conclude with some speculative directions of where the new ideas might lead.

Keywords: nonimaging optics, thermodynamics, geometric flowline,

*Corresponding author, email to: rwinston@ucmerced.edu

1 Introduction

Nonimaging Optics is the theory of thermodynamically efficient optics and as such depends more on thermodynamics than on optics. It is by now a key feature of most solar concentrator designs. What is the best efficiency possible? When we pose this question, we are stepping outside the bounds of a particular subject. Questions of this kind are more properly in the province of thermodynamics which imposes limits on the possible (like energy conservation) and the impossible (like transferring heat from a cold body to a warm body without doing work). And that is why the fusion of the science of light (optics) with the science of heat (thermodynamics), is where much of the excitement is today. When the problem of maximal concentration from extended sources was first confronted², the tools of Hamiltonian mechanics were utilized, because classical geometrical optics was concerned with "point sources"^{3,4}. In this paper we first present the failure of classical point source optics. The purpose to repeat the illustration of this paradox, is to show that, the conventional point and line understanding of geometric optics cannot fully represent the nature of the physics behind modern optical designs.

As the field (nonimaging optics) developed, it gradually became clear that the second law of thermodynamics was “the guiding hand” behind the various new designs. If we were asked to predict what currently accepted principle would be valid 1,000 years from now⁵, The Second Law would be a good bet. The purpose of this communication is to show how nonimaging optics can be derived from this principle. As a result, “optics” recedes into the background and we are left with abstract probabilities, the ingredients of entropy and information theory. This paper is organized as follows: section 2 to 4 provide a brief review of nonimaging optics with the emphasis on its connection to thermodynamics. Section 5,6 and 7 conclude with some speculative directions of where the new ideas might lead, particularly how flowline can illustrate the thermodynamic origin of nonimaging concentrators.

2 The failure of the imaging optics.

Conventional optics uses imaging ideas, or point sources, to represent the geometry of optical sources. This leads to conclusions in conflict with fundamental physics⁶ (Fig. 1). In this paradox, the point object A is at the center of a spherical reflecting cavity, and it is also one focus of an elliptical reflecting cavity. The point object B is at the other focus. If we start A and B at the same temperature, the probability of radiation from B reaching A is clearly higher than A reaching B, as shown by the arrows. So we conclude that A warms up while B cools off, in violation of the second law of thermodynamics (heat only goes from higher temperature to lower temperature). The paradox is resolved by making A and B extended objects, no matter how small. In fact, a physical object with temperature has many degrees of freedom and cannot be point-like. Then the correct cavity is not elliptical, but a nonimaging shape that ensures efficient equal radiation transfer between A and B⁶. It is worth mentioning that the correct nonimaging

design does not converge to the ellipse/sphere configuration in the limit that the size of A and B tend to zero.

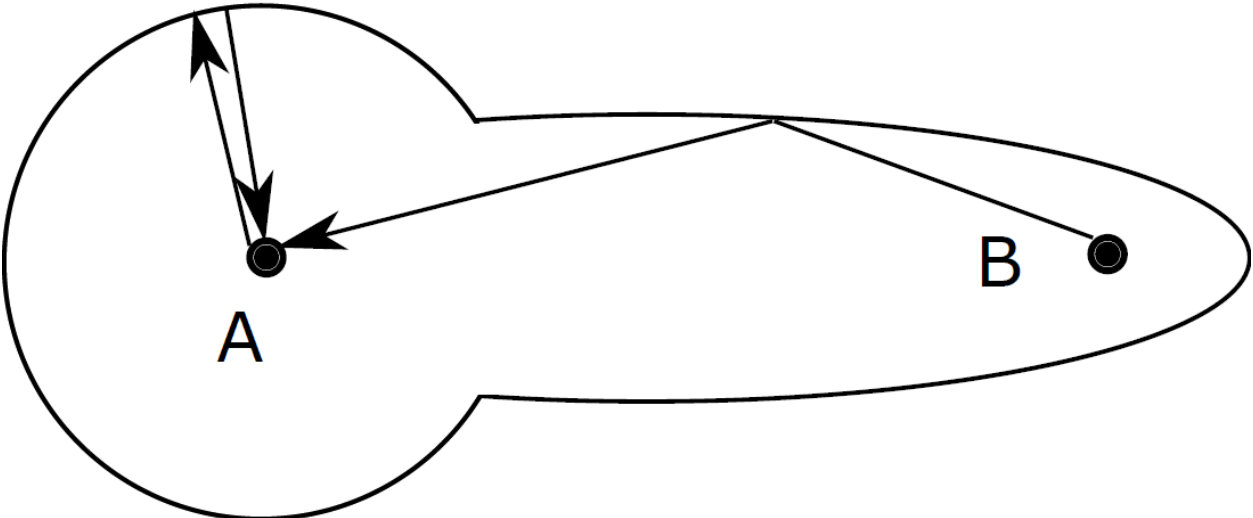

Fig. 1 The ellipse paradox: the ellipse images “point” object B (right) at “point” object A (left) “perfectly” and the sphere images A on itself “perfectly”.

3 Nonimaging optics, designing optimal optics according to thermodynamics.

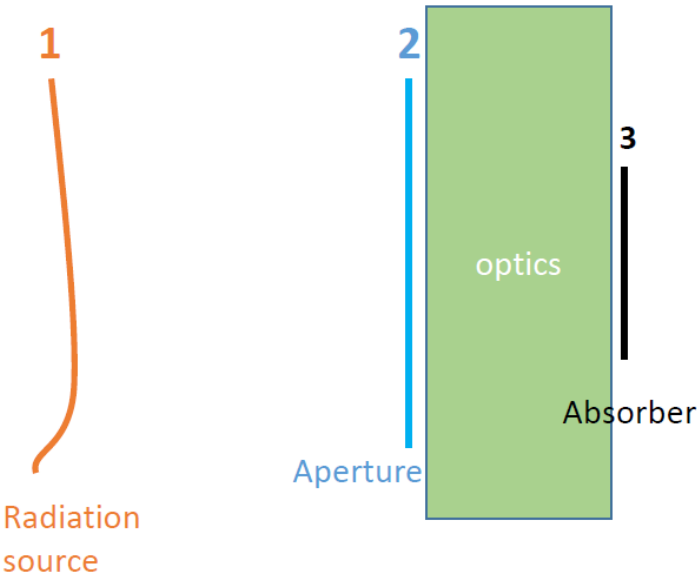

Fig. 2 Illustration of a concentrator, the optics between the aperture and the receiver is arbitrary.

If we take a general concentration problem, as shown in Fig. 2, and ask the question of, what can be done to achieve the “best concentration”? In another word, what optics should be put into the box to achieve the maximum ratio between the areas of the aperture and the absorber?

$$C = A_2/A_3 \quad (1)$$

Here C is the geometric concentration ratio. A is area. In order to answer such a question, we have to make a reasonable assumption; all the energy from the radiation source that enters the aperture should reach the absorber:

$$Q_{12} = Q_{13} \quad (2)$$

Here Q represents the radiative heat (watts) that goes from one surface to another. A concentrator that does not meet such a requirement will have not achieved what is possibly the “best”. In other word, if two concentrators can be both designed to achieve the maximum radiation flux at the absorber, we would naturally choose the “better” concentrator which passes all energy from the aperture to the absorber instead of the one that is not capable of doing the same.

No other assumptions will be needed. We are considering only the geometric optics, i.e. the radiative heat transfer is determined by the geometric setup and the shape of the optics, independent of the wavelength of the photons. (Dispersion would have to be considered differently, or approximated with the major wavelength). We can choose the objects to be of any temperature, and the result of the heat transfer due to the geometric optics should always satisfy the thermodynamic laws. Here we pick a special case, i.e. the source and sink being both blackbody and at equal temperature. The aperture being a fully transmitting object can also be treated as a blackbody with the same temperature. The answer to the “best concentration” question can be found with the following thermodynamic arguments:

Second law demands that:

$$\begin{aligned}
 Q_{12} &= Q_{21} \\
 A_1 \sigma T^4 P_{12} &= A_2 \sigma T^4 P_{21} \\
 A_1 P_{12} &= A_2 P_{21} \tag{3}
 \end{aligned}$$

Here P_{AB} is defined as the probability of heat from surface A reaching surface B, through any optical surface such as reflection, refraction etc. Or,

$$P_{AB} = \frac{\text{number of rays reaching surface B via optics}}{\text{number of rays emitted by surface A}} \tag{4}$$

It is a more general concept compared to the idea of view factor in radiative heat transfer ⁷, where only rays going from one surface directly to the other are considered.

(3) represents the reciprocity of the radiative heat transfer, or the second law of thermodynamics, which states that a cold object cannot heat up a hot object.

Similar to (3), we can conclude:

$$\begin{aligned}
 Q_{13} &= Q_{31} \\
 A_1 P_{13} &= A_3 P_{31} \tag{5}
 \end{aligned}$$

From (2), or the first law of thermodynamics which states that energy is conserved, we can derive that

$$\begin{aligned}
 Q_{12} &= Q_{13} \\
 A_1 P_{12} &= A_1 P_{13} \tag{6}
 \end{aligned}$$

Combining (3)(5)(6) we conclude with

$$\begin{aligned}
 A_2 P_{21} &= A_1 P_{12} = A_1 P_{13} = A_3 P_{31} \\
 A_2 P_{21} &= A_3 P_{31}
 \end{aligned}$$

$$C = \frac{A_2}{A_3} = \frac{P_{31}}{P_{21}} \quad (7)$$

For a lot of problems P_{21} is predetermined due to the setup of the problem, e.g. solar concentration problems where the sun subtends a certain angle. However, P_{31} can be manipulated with proper optical design. From (7) we find that the C_{max} is limited by $1/P_{21}$ and C_{max} can be reached when $P_{31} = 1$.

$$C \leq C_{max} = \frac{1}{P_{21}} \quad (8)$$

The physical meaning of this is that an ideal concentrator limits all the “light” coming from the absorber to be within the range of the source. In other word, an ideal concentrator is also a perfect illuminator where the illumination pattern has a sharp cut off edge.

4. Tools to design thermodynamically efficient concentrator/illuminators.

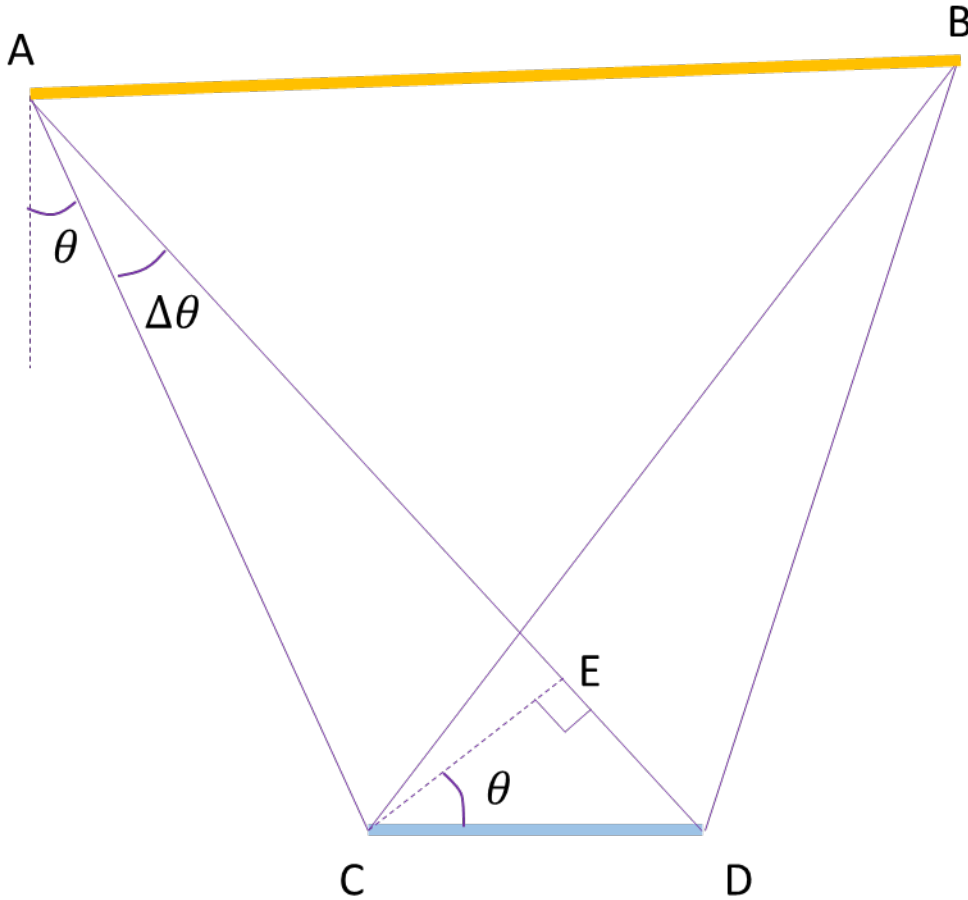

Fig. 3 The Hottel's strings of the source and aperture pair.

Hoyt Hottel, an MIT engineer working on the theory of furnaces^{7,8}, showed a convenient method for calculating radiation transfer between walls in a furnace using “strings”. We now recognize this was much more than a shortcut to a tedious calculation, but instead the basis of an elegant algorithm for thermodynamically efficient optical design. In order to calculate the P_{21} from previous section, we use the Hottel's strings on the radiation source 1 and aperture 2.

$$P_{21} = \frac{(\overline{AD} + \overline{BC}) - (\overline{AC} + \overline{BD})}{2\overline{CD}} \quad (9)$$

As the source 1 recedes into infinitely far away, $\Delta\theta$ approaches 0 and $\overline{AC} = \overline{AE}$. If we keep the setup symmetric, i.e. $\overline{AD} = \overline{BC}$ and $\overline{AC} = \overline{BD}$, then:

$$P_{21} = \frac{2(\overline{AD} - \overline{AC})}{2\overline{CD}} = \frac{\overline{DE}}{\overline{CD}} = \sin(\theta)$$

$$C_{max} = \frac{1}{P_{21}} = \frac{1}{\sin(\theta)} \quad (10)$$

(9) is exactly the same as the C_{max} derived with the etendue conservation^{2,9}, implying a relationship between the nonimaging optics and the thermodynamically optimal designs.

5 String and flowline

Flowline is a vector field that can be defined in 3D as⁹

$$\vec{J} = (\int dp_y dp_z, \int dp_x dp_z, \int dp_y dp_x) \quad (11)$$

Here \vec{J} is the flowline vector^{10 11}. With a simple treatment of infinitely extrusion of a 2D cross section, one can find that the 2D flowline vector is always bisecting the two extreme rays of the flowline source^{9 12} (Fig. 4). In Fig. 5, a radiation source/sink pair (red line and green line) are shown. If we trace back the flowline from the edge of the other object to itself, the corresponding length h , which represents the etendue volume of the radiation heat transfer, are the same on either side. This also echoes the Kirchhoff's law, that the 2nd law of thermodynamics forbids the geometry of radiative heat transfer, from being asymmetric.

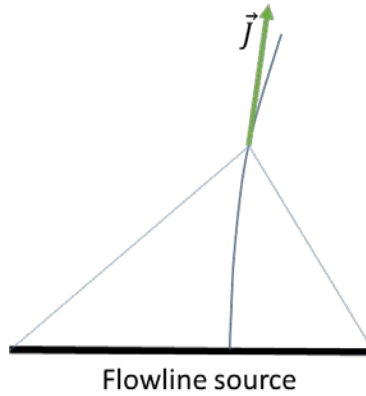

Fig. 4 Flowline of a line source in 2D is parabola due to its property of always bisecting the two foci directions.

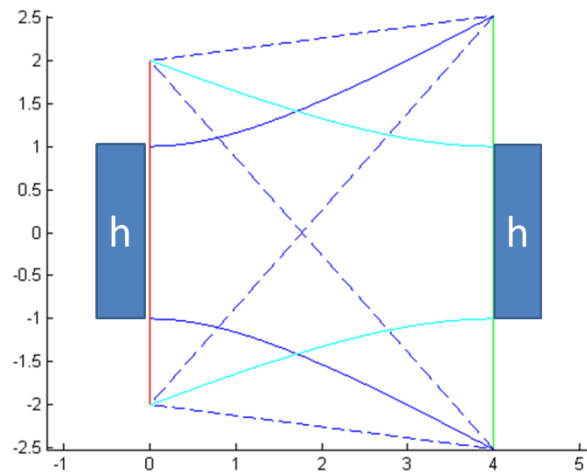

Fig. 5 Tracing the flowline between two lines.

Another look at the problem shows us that, because of the well-known property of hyperbola, the difference of the distances to the foci remains constant (Hottel's string). The etendue between the radiation source and sink is also represented by the differences to the foci by Hottel's string formula (9). The reader might wonder how the Greek mathematicians would feel about this connection between geometry and thermodynamics. To our knowledge, flowline is the closest realization of a 3D Hottel's strings. At least some of the 2D flowlines, generalize to ideal 3D systems.

6 Asymmetric nonimaging design

Although equation (9) is limited to the symmetric case of nonimaging design, however, many¹³⁻
¹⁶ have pointed out that the concept of nonimaging designs, or the thermodynamically optimal
 design that satisfies that $C_{max} = \frac{1}{P_{21}}$, is not limited to the symmetric cases. (Fig. 6)

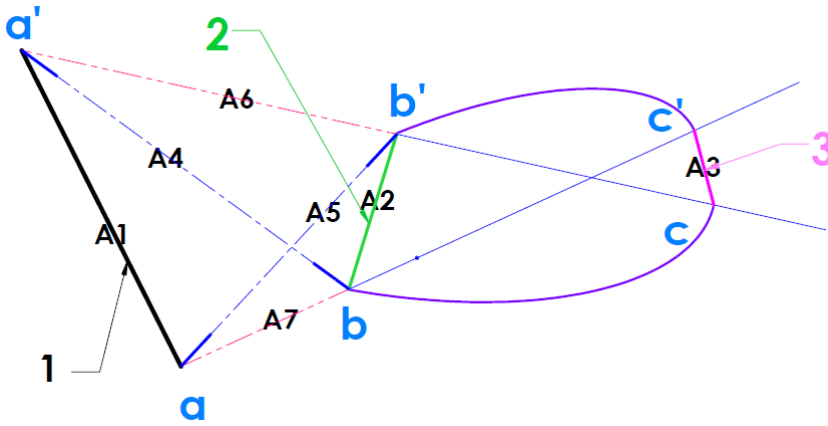

Fig. 6 The asymmetric application of the string method in CEC.

Here 1 and 3 are predetermined radiation source and sink. To form an ideal concentrator with $C = C_{max}$, a string $ac'c$ is tightly pinned down on points a, c , point c' is moved, following an elliptical path, to b' . Such a string method is consistent with the previous examples of CPC.

7 The linkage between flowlines and mirrors.

7.1 The usage of flowline as mirror in ideal concentrators.

From equation (11), the flowline vector can be represented in a more suggestive form as $\vec{j} = \int \hat{n} d\Omega$. Which is the average direction of the energy flow. This agrees with the flowline bisecting the rays from 2D source. This also agrees with the well-known Snell's law of reflection (Fig. 7).

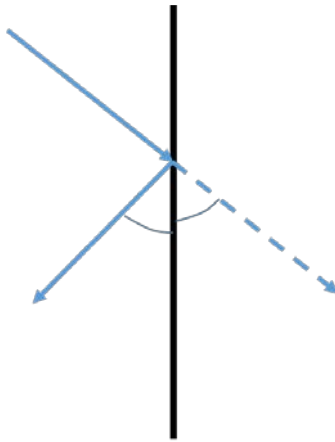

Fig. 7 The mirror also bisects the original ray's direction and its reflection direction

This connection between mirrors and flowlines can be utilized to construct ideal concentrators. Refer to Fig. 8, the flowline inside an ideal concentrator can be traced out by evaluating the average direction of all the rays from the flowline source. These rays can be either directly from the source (blue arrows) or indirectly reflected by the mirrors (green arrows). The two extreme rays (red arrows) are noted and the direction bisecting them is the flowline direction. By tracing out these directions the flowline can be found to be controlled by the ideal concentrator (CEC in this case) to converge on the radiation source.

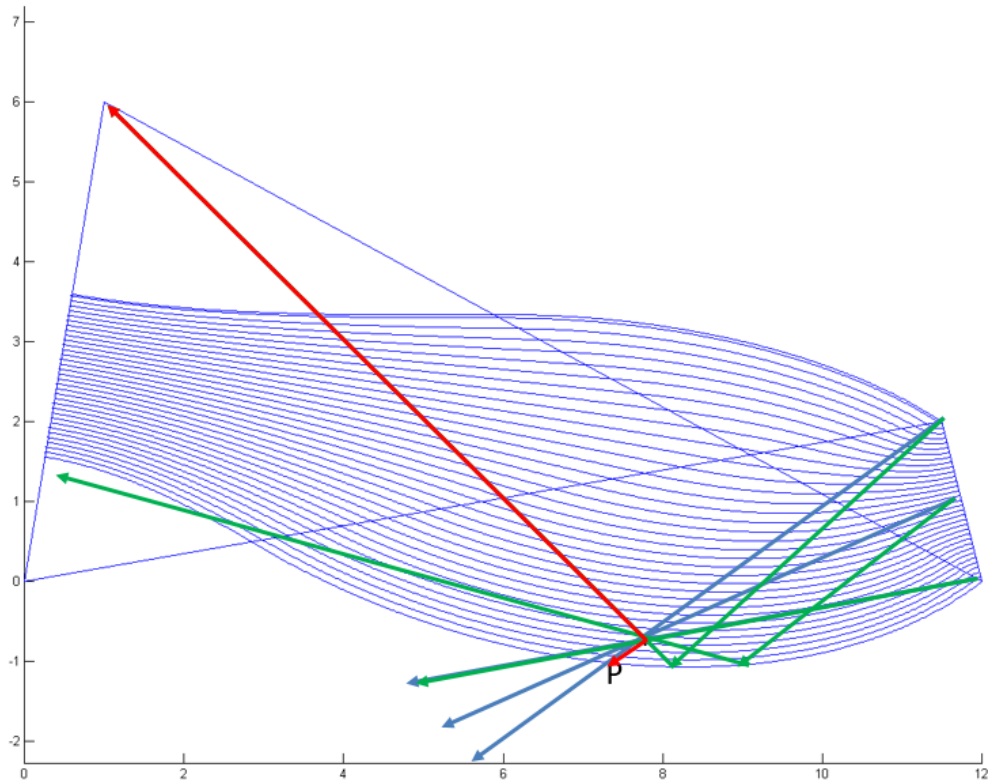

Fig. 8 The flowline inside a CEC.

We can pick any pair of such flowlines and form an ideal concentrator. As shown in Fig. 9, the yellow line represents the aperture, the black lines represent the reflecting walls, and the purple line represents the absorber. The intriguing result is, we can trace the flowline and see how the ideal concentrator “guides” the radiation absorber onto a section in the radiation source (red line). Such a section has the same width of the radiation absorber, which implies that the extendue of the absorber is fully filled by rays coming from the source. Or, $P_{31} = 1$, as required by the maximum concentration ratio Eq. (8).

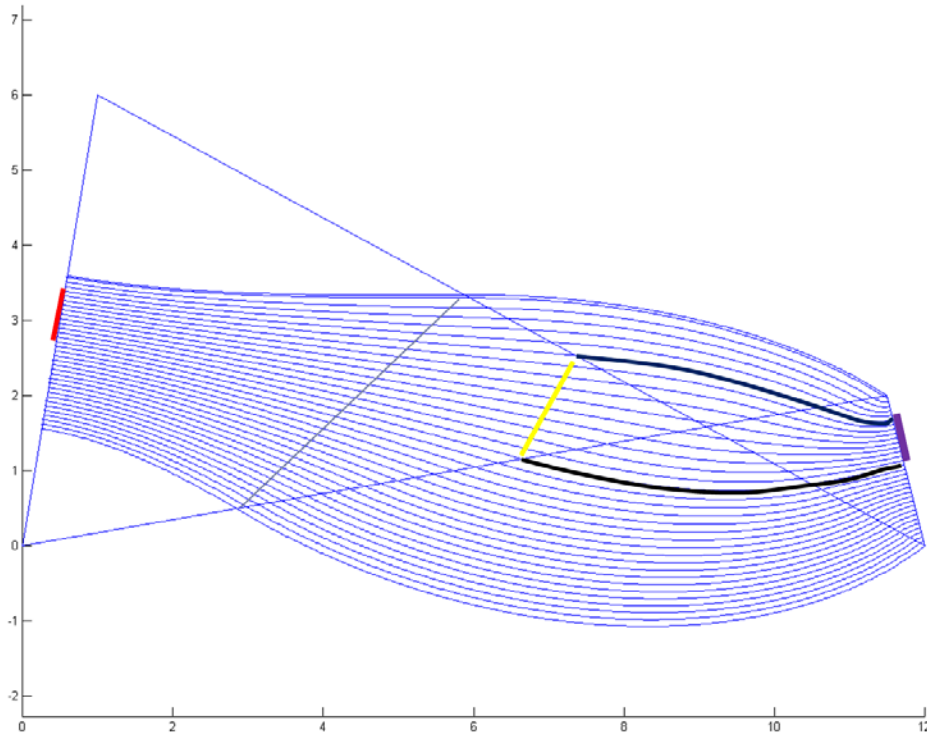

Fig. 9 Flowline ideal concentrator.

7.2 The thermodynamic implication of the flowline mirrors

If we cover the full length of the flowline with mirrors from the radiation absorber to the radiation source, then the etendue of the absorber is the same of the etendue between the mirrors at the source, and both are fully populated. In other word, the “geometric capacity” of both the purple area and the red area, are fully occupied by the radiation coming from the other. Each of them sees only the other, not itself, not any other radiation source. This (as an etendue guide), however, will not concentrate, but it has within it the element to construct concentrators. By cutting the aperture at the points where flowlines are crossing over the diagonal lines(the end points of the yellow line), we get the concentrators (black lines). The reason for such a cutting position, is still unknown to us. This is a new perspective of the ideal concentrators. This etendue transferring is interesting in itself.

One seemingly contradictory result of the flowline is the curious case of CPC flowline. The flowlines right above the aperture of CPC are all parallel. If they continue to be parallel all the way to the radiation source, then the projected area by the flowline pairs, on the radiation source, will be the same as the aperture, instead of being the same as the radiation absorber. This seemingly contradictory conclusion can be explained this way: the flowlines of CPC right above the aperture are, indeed, still hyperbolas. However, because it is far away from the radiation source, it appears to be “parallel”, just the same as the hyperbolas with parallel asymptotes. As the flowline goes closer to the radiation source, over the infinite distance between the aperture and the radiation source, it still narrows down between each other, or becomes denser, resulting in the same width as the radiation absorber.

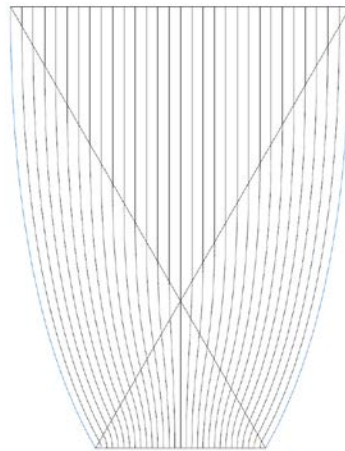
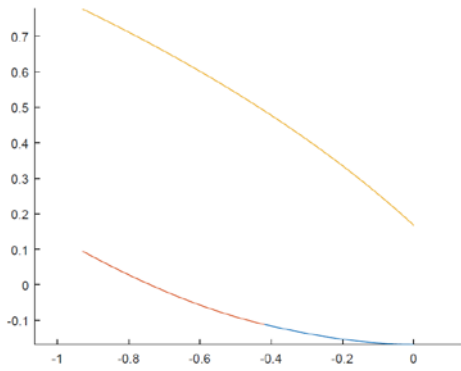
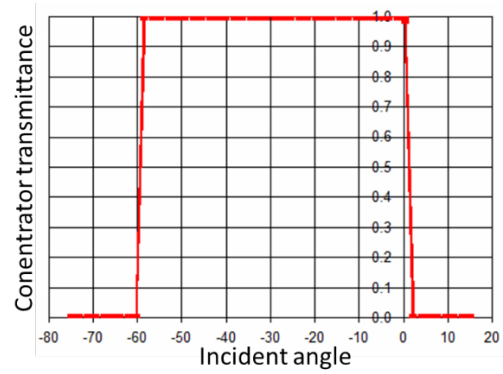

Fig. 10 flowlines of CPC, being parallel and vertical at the aperture.

provided another degree of freedom to the ideal concentrator design by allowing the tilting angle of the aperture to be also variable. Such a result cannot be achieved by simply tilting the conventional CEC¹⁷, or adding a secondary concentrator to the symmetric concentrator¹³. The detailed ray tracing can be found at¹⁸.



(a) The concentrator constructed based on flowline, blue is a hyperbola curve, red and orange are elliptical curves.



(b) The incident angle modifier shows that the transmittance response according to the angle is not symmetric, in this case, -60 to 0 degrees.¹⁸

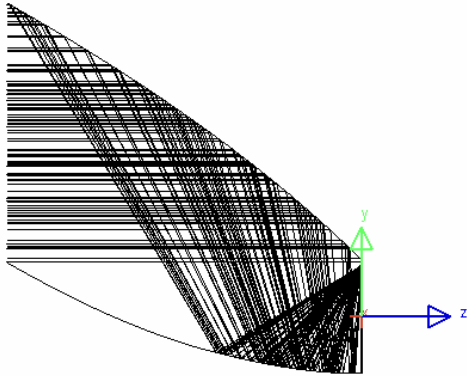

(c) Edge ray tracing at 0 degrees

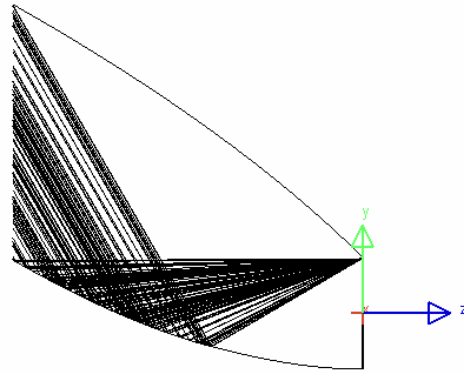

(d) Edge ray tracing at -60 degrees

Fig. 13 The optical simulation of an ideal, nonimaging, asymmetric, flowline design, which meets the requirement of aperture being parallel to the absorber.

8 Conclusion and further discussion

This paper has discussed the essence of ideal concentration. Thermodynamically speaking, the flux at the absorber surface cannot exceed the flux at the source surface. This is a fundamental principle that we cannot violate according to the second law of thermodynamics, even within the framework of geometric optics. Under the assumption that the most efficient concentrators will allow all the energy arriving at the aperture to be transmitted onto the absorber, we observe that the probability of any “virtual rays” coming from the absorber will also reach and only reach the absorber.

With the help of Hottel’s strings and geometric flowlines, we demonstrated that at least some of the ideal concentrators have such a property: the flowline along the ideal concentrators will “guide” the etendue from the absorber to the source, the region between the flowline, both at the source and at the absorber, are geometrically equal. This shows that flowline itself, being only under the constraints of geometry, is able to predict if a concentrator is ideal.

Furthermore, the flowline generated with the 2D ideal concentrator, can form infinitely more ideal concentrators. Specifically, any pair of such flowlines can construct a new ideal concentrator which meets the requirement of $P_{31}=1$ and $C_{\max}=1/P_{21}$. Using this additional degree of freedom we demonstrated how a flowline ideal concentrator can be designed according to additional requirements such as a certain tilting direction of the aperture.

We have seen that the Hottel’s strings can be generalized with the geometric flowline. In some cases, this generalization prompts the question of its usage in 3D, because unlike the Hottel’s string, flowline is naturally three dimensional. If one can successfully solve the problem of generating Hottel’s string design using geometric flowline in the 2D cases, one may be able to

reapply the same principles into 3D cases. In that sense the flowlines opens up the possibility of generalization of all current nonimaging optics 2D design, which are constructed conventionally by Hottel's strings, into 3 dimensions.

References

1. R. Winston, "Thermodynamically efficient solar concentrators," *J. Photonics Energy* **2**(1), 025501, International Society for Optics and Photonics (2012) [doi:10.1117/1.JPE.2.025501].
2. R. WINSTON, "Light Collection within the Framework of Geometrical Optics," *J. Opt. Soc. Am.* **60**(2), 245, Optical Society of America (1970) [doi:10.1364/JOSA.60.000245].
3. R. Luneburg and M. Herzberger, *Mathematical theory of optics* (1964).
4. M. Born and E. Wolf, *Principles of optics: electromagnetic theory of propagation, interference and diffraction of light* (2000).
5. S. Carroll, *From eternity to here: the quest for the ultimate theory of time* (2010).
6. W. T. Welford and R. Winston, "The ellipsoid paradox in thermodynamics," *J. Stat. Phys.* **28**(3), 603–606 (1982) [doi:10.1007/BF01008327].
7. M. F. Modest, *Radiative Heat Transfer*, Academic Press (2013).
8. H. Hottel, "Radiant heat transmission," *Heat Transm.* (1954).
9. R. Winston, J. C. Miñano, and P. Benítez, *Nonimaging Optics*, Academic Press (2005).
10. P. Moon and D. Spencer, "The photic field," Cambridge, MA, MIT Press. 1981. 265 p. (1981).
11. A. Garcia-Botella et al., "Ideal 3D asymmetric concentrator," *Sol. Energy* **83**(1), 113–117 (2009) [doi:10.1016/j.solener.2008.07.004].
12. B. Colabewala, L. Jiang, and R. Winston, "String method of nonimaging optics from a radiation theory perspective," 25 August 2015, 957202 [doi:10.1117/12.2191946].
13. A. Rabl, "Comparison of solar concentrators," *Sol. Energy* **18**(2), 93–111 (1976) [doi:10.1016/0038-092X(76)90043-8].
14. D. R. Mills and J. E. Giutronich, "Asymmetrical non-imaging cylindrical solar concentrators," *Sol. Energy* **20**(1), 45–55 (1978) [doi:10.1016/0038-092X(78)90140-8].
15. L. Jiang and R. Winston, "Asymmetric design for Compound Elliptical Concentrators (CEC) and its geometric flux implications," *SPIE Opt. Eng.* ... (2015).
16. E. M. Kritchman, "Asymmetric second-stage concentrators.," *Appl. Opt.* **21**(5), 870–873, Optical Society of America (1982) [doi:10.1364/AO.21.000870].
17. A. Rabl and R. Winston, "Ideal concentrators for finite sources and restricted exit angles.," *Appl. Opt.* **15**(11), 2880–2883, Optical Society of America (1976) [doi:10.1364/AO.15.002880].
18. Lun Jiang, "raytrace - YouTube," Ray tracing of asymmetric flowline design, <<https://www.youtube.com/watch?v=x8GVIFh5z2s>> (accessed 5 August 2016).