

Lawrence Berkeley National Laboratory

Recent Work

Title

ENERGY DISPERSIVE X-RAY FLUORESCENCE SPECTROMETRY USING PULSED X-RAY EXCITATION

Permalink

<https://escholarship.org/uc/item/8v51x515>

Author

Jaklevic, J.M.

Publication Date

1975-08-01

Presented at the 24th Annual Denver X-Ray
Conference, Denver, CO, August 6 - 8, 1975

LBL-4248

ENERGY DISPERSIVE X-RAY FLUORESCENCE SPECTROMETRY
USING PULSED X-RAY EXCITATION

J. M. Jaklevic, D. A. Landis, and F. S. Goulding

August 1975

Prepared for the U. S. Energy Research and
Development Administration under Contract W-7405-ENG-48

For Reference

Not to be taken from this room

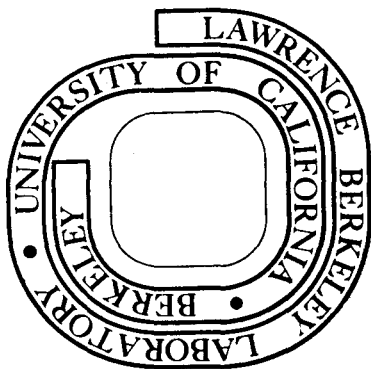

LBL-4248

0 0 0 4 4 0 1 9 5 8

DISCLAIMER

This document was prepared as an account of work sponsored by the United States Government. While this document is believed to contain correct information, neither the United States Government nor any agency thereof, nor the Regents of the University of California, nor any of their employees, makes any warranty, express or implied, or assumes any legal responsibility for the accuracy, completeness, or usefulness of any information, apparatus, product, or process disclosed, or represents that its use would not infringe privately owned rights. Reference herein to any specific commercial product, process, or service by its trade name, trademark, manufacturer, or otherwise, does not necessarily constitute or imply its endorsement, recommendation, or favoring by the United States Government or any agency thereof, or the Regents of the University of California. The views and opinions of authors expressed herein do not necessarily state or reflect those of the United States Government or any agency thereof or the Regents of the University of California.

ENERGY DISPERSIVE X-RAY FLUORESCENCE SPECTROMETRY USING PULSED
X-RAY EXCITATION*

J. M. Jaklevic, D. A. Landis and F. S. Goulding
Lawrence Berkeley Laboratory, University of California
Berkeley, California 94720

ABSTRACT

An energy dispersive X-ray fluorescence spectrometer using pulsed X-ray excitation has been developed for use in large-scale environmental analysis programs. A grid controlled X-ray tube is coupled with variable secondary fluorescence targets to analyze for a wide variety of elements with almost optimum sensitivity. The operation of the pulsed tube in a feedback loop with the semiconductor detector spectrometer results in a substantial increase in output counting rates without pile-up. The loop functions by turning off the excitation immediately upon detection of an event by the spectrometer. Pile-up events are virtually eliminated and the X-ray tube's available anode power is better utilized.

The electronic control of this feedback mode results in some unique features in the response of the system to varying sample mass. These features are discussed in detail. Experimental results for sensitivity and accuracy over the range of elements measured are presented. Early operating experience with the unit indicates increases of counting rates of a factor of five compared with similar conventional systems.

* This work was performed under an Interagency Agreement between the Environmental Protection Agency and the U. S. Energy Research and Development Administration.

INTRODUCTION

The ability to perform rapid X-ray fluorescence analysis with conventional semiconductor detector spectrometers is limited by the maximum counting rates allowed by the pulse-processing electronics. The excellent energy resolution of such spectrometers is achieved in part through the use of relatively long pulses and measurement times. Since the time distributions of detected pulses is normally random, pulse pile-up is a serious problem at high counting rates. Total pulse widths often approach 50 μ s or more resulting in practical output counting rates considerably less than 10^4 counts per second. In an earlier publication we described the first use of a technique for pulsing the X-ray excitation resulting in a substantial increase in the output counting rates (1). The basic method can also be used in particle accelerator experiments (2) and in electron probes (3). The present paper describes application of the pulsed excitation technique to a practical analytical system.

BASIC CONCEPTS

Semiconductor spectrometer systems intended to operate at high counting rates typically use pile-up rejection circuit to prevent distortion of the pulse-height spectrum due to interference between successive pulses. These circuits measure the interval between successive pulses and reject those which fail to satisfy certain criteria.

Figure 1 A, B and C show the timing sequence of pulses which accompany the detection of an X-ray in the detector. The fast output indicates the time of arrival of an event and is used to detect the occurrence of pile-up. The slow output has been filtered to achieve a symmetric Gaussian shape with peaking time of τ_p . Associated with the detection of the event is a dead time $\tau_d \approx 2\tau_p$ during which pile-up may occur. Typical values for the dead time vary from 20 to 70 μ s.

Figure 2 b) shows the rate of the non-pile-up output pulses as a function of input counting rate. The scale is in units of $(1/\tau_d)$. The curve can be derived from elementary probability considerations assuming a random arrival distribution and is represented by the equation:

$$N_o = N \exp^{-N\tau} \quad (1)$$

where N_0 and N are the average output and input counting rates and τ is the dead time of the pile-up circuit. Since most circuits reject a pulse if it is preceded by an earlier pulse in a time less than τ_d or if it is followed by one in less than τ_p , the curves assume $\tau = 3\tau_d/2$. The maximum possible output rate achieved under such conditions is less than $1/4\tau_d$.

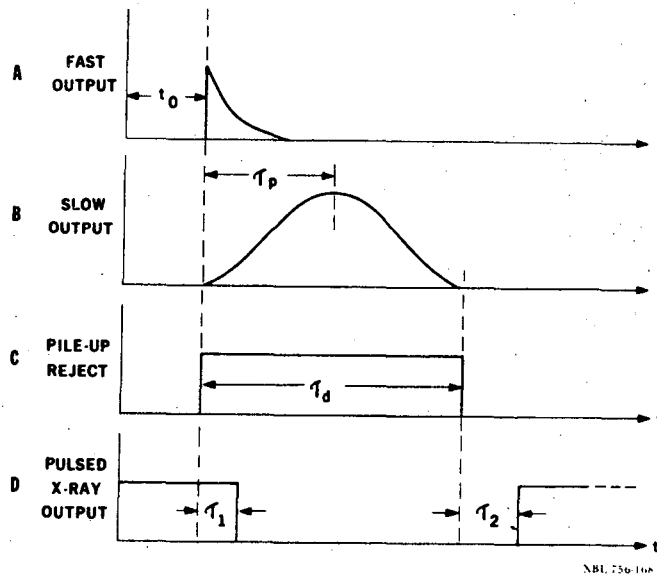

Fig. 1. Timing sequence of X-ray spectrometer outputs.

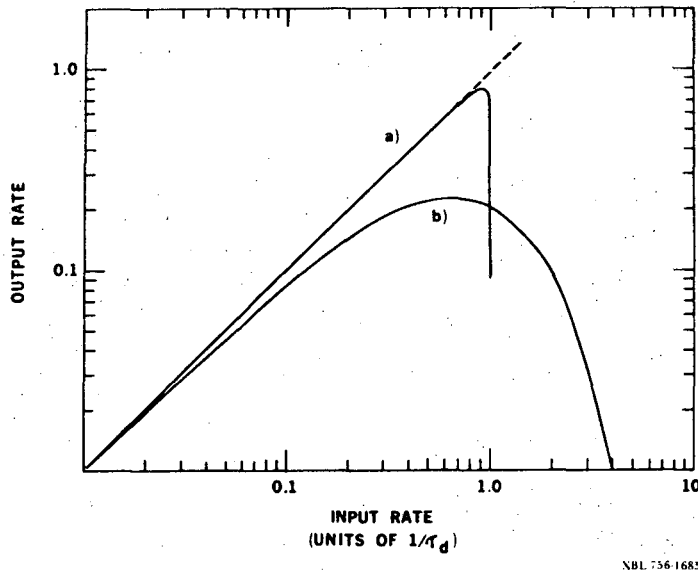

Fig. 2. Output rate vs. input rate

The pulsed tube overcomes this limitation by eliminating the possibility of a further event arriving during the time τ_d taken to process a pulse. Figure 3 shows a schematic diagram of the simplest method of pulsed excitation. A discriminator on the fast output of the detector senses the arrival of an event and initiates turning off the pulsed X-ray tube for an interval equal to the time τ_d required to fully process the first pulse. Ideally no pile-up can occur and the output rate is equal to the input rate up to a maximum input rate of $1/\tau_d$. At this point the events are essentially periodic.

In actual systems there is a slight delay in sensing the event and turning off the tube (τ_1 in Fig. 1 D resulting from the finite propagation time of the signal from the detector to the X-ray tube grid. During this period, pile-up can occur at the higher counting rates. However, since this time interval is typically small (< 300 ns) the pile-up is almost negligible. The curve in Fig. 2 a) shows the non-pile-up output of a pulsed system. The slight curvature near the

limiting rate of $1/\tau_d$ is a result of the pile-up at higher rates. If the input rate is further increased after achieving a periodic rate at $N = 1/\tau_d$, all the additional events are pile-up pulses and the output of undistorted pulses drops rapidly to zero.

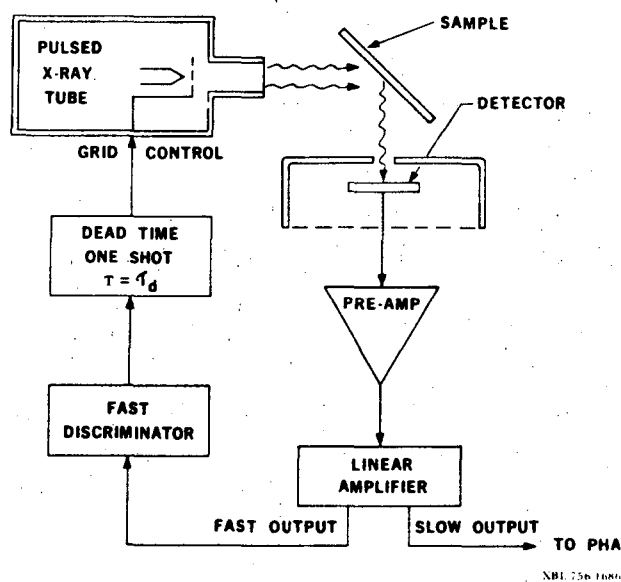

Fig. 3. Schematic of a pulsed excitation system

CONTROL OF THE PULSED TUBE

The operation of a pulsed X-ray tube in a general purpose analytical system requires unique control features in order to function effectively. As a consequence of the behavior described in the preceding paragraph, the tube power must be limited in the case of heavy samples to avoid excessive pile-up. On the other hand, full effectiveness of the pulse excitation method will not be achieved unless the power is adequate for the counting rate to approach its

limiting value. Since the excitation intensity is varied depending on the sample mass, quantitative analysis is complicated by the fact that the concept of live time and counting rate have lost their usual significance.

In any discussion of the operation of a pulsed analytical system it is necessary to distinguish between the instantaneous (or pulsed) and the average values of the tube current, anode power dissipation, and detector counting rate. Since the pulse widths we use are short compared with thermal time-constants, the maximum power rating of the anode can be assumed to apply to the average anode dissipation; instantaneous pulsed power levels can far exceed the maximum dissipation. Also, since signal pile-up can occur only when the tube is on, it is a function of the instantaneous (peak) counting rate rather than the average output rate.

The operating modes of the control loop can best be discussed by considering the response of the system as a function of increasing sample mass. This corresponds to an increase in the instantaneous counting rate for a fixed instantaneous tube power. Referring to Fig. 4, two distinct operating regions can be recognized:

- 1) For very small sample masses the probability of detection of X-rays is low and the tube should run at its maximum average power rating to achieve the highest possible counting rate. Since the rate is low, effects due to pile-up are negligible and the difference between pulsed and continuous operation is insignificant. As the mass is increased, the off time of the tube begins to be significant and the duty factor is measurably reduced. At this point the instantaneous counting rate is not large enough to cause significant pile-up. Since the tube is now turned off for part of the time, the tube pulsed current can be increased to maintain the average tube power at its maximum rating. In this first region, therefore, the average power is maintained at its maximum value and the counting rate increases linearly with sample mass.

- 2) As the mass is increased further, the average time of arrival of the first event (after the tube is turned on) becomes comparable to the time required to sense a signal and turn off the tube. The probability of detecting a second event in this time then becomes significant and pile-up becomes a problem. In order to

maintain this pile-up probability within tolerable limits, the tube pulsed current must be reduced in order to increase the average time required to detect the first event. In this region the tube current is controlled to maintain the instantaneous counting rate below some predetermined value.

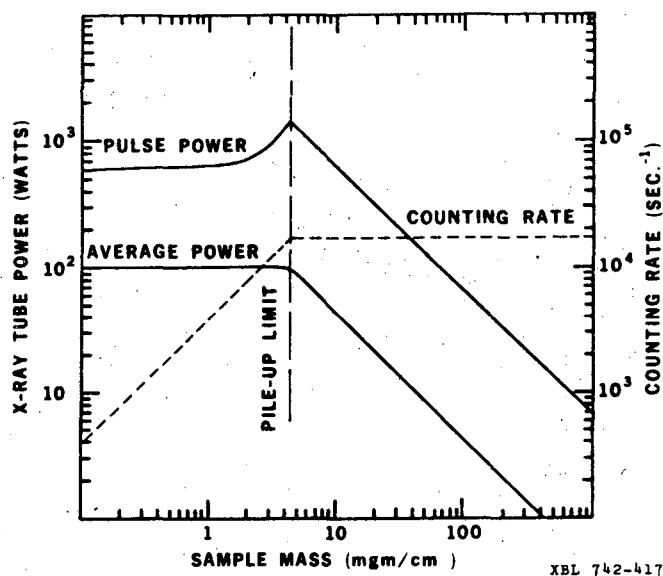
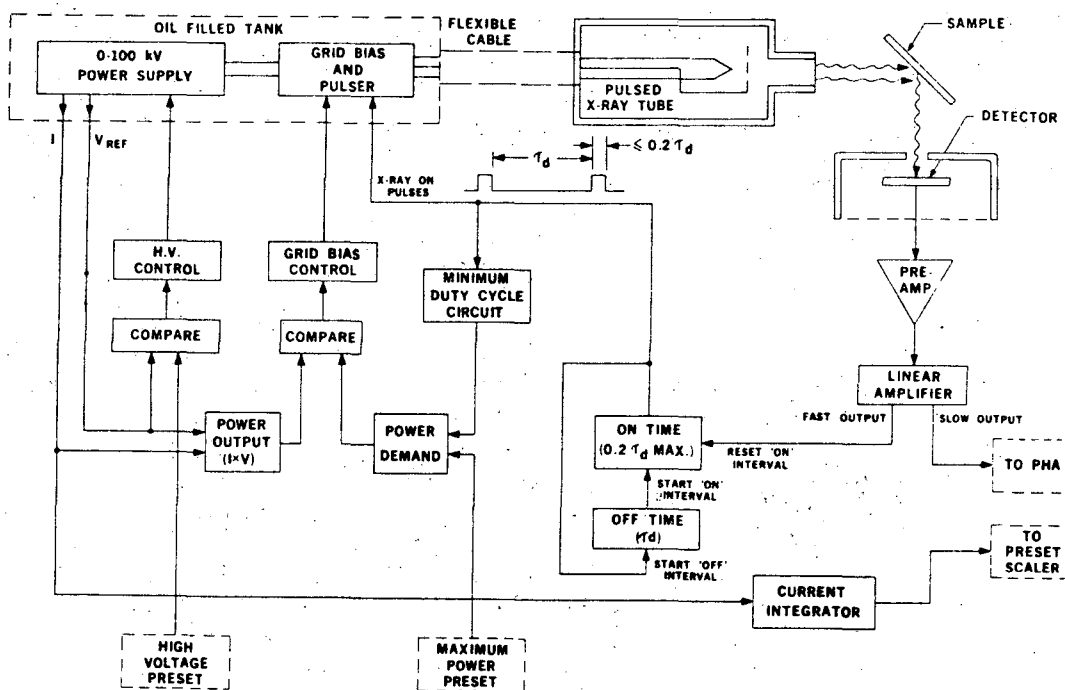

Fig. 4. Characteristics of a pulsed excitation system as a function of sample mass.

The feedback system shown in Fig. 5 achieves these conditions. The peak tube current is controlled by varying the X-ray tube grid bias while driving the grid with a constant amplitude positive pulse. The timing and duration of the drive pulse is regulated to achieve the performance discussed in the previous paragraph.



NBL 756 1688

Fig. 5. Schematic of complete pulsed X-ray tube control system.

The grid pulser circuit is basically the same as that shown in Fig. 3 with the addition of a maximum ON time control. The drive pulse to the X-ray tube is limited to a maximum duration of about $0.2 \tau_d$ when no detector signals occur to terminate the ON period in a shorter time. This limits the maximum duty factor to 16% and controls the maximum power level used for the low counting rate region of Fig. 4. The off period is determined by a preset pulse of width τ_d . It is apparent that as the counting rate is increased the duty factor will be reduced since the pulser will be reset more often by the detector output. This is the usual pulsed mode of operation.

The average power level in the tube is the product of the duty factor and the pulse power level. The grid bias control operates in a feedback loop which compares the average power, determined by the

product of the average current and the tube voltage, with the demand power level. The demand power level is set either by an external control in the low count rate regime or by a special circuit which measures the average duty cycle of the grid pulser at high counting rates. In the first region the power is maintained constant despite the varying duty factor. As the mass is increased to a point where the average ON time is short and pile-up becomes a problem, the power reference is reduced by requiring that the average duty cycle be above a predetermined value. This ensures that pile-up during τ_1 is not a problem. In a typical system with a delay $\tau_1 = 200$ ns the minimum average drive pulse width is set at $4 \mu\text{s}$ corresponding to a 5% pile-up probability.

Since the X-ray tube pulse current and the duty factor are automatically reacting to changes in sample mass and composition, calibration of the analytical system cannot assume a constant excitation for equal live-time intervals. Instead it is necessary to use the average electron beam current in the tube as a measure of excitation intensity. To find the total flux during a counting period, the current must be integrated. The integrator produces a series of pulses, each corresponding to a discrete amount of collected charge. The calibration is then referenced to a fixed number of these pulses. The time interval required to accumulate a given number of these pulses depends on the sample mass; this means that a longer time is required to accumulate a given number of charge pulses when the sample is large. In practice, it is not necessary to accumulate as many charge pulses in this case and the analysis time does not increase.

PULSED TUBE DESIGN

The pulsed X-ray tube was designed to be compatible with the close-geometry, multiple-secondary target system previously built in our laboratory (4). This geometry requires that the beam be projected down a tube to a grounded anode located near the secondary target as shown in Fig. 6. The electron optics necessary for generating such a beam and the necessity of pulsing the grid circuits in the negative high voltage terminal presented unique design problems.

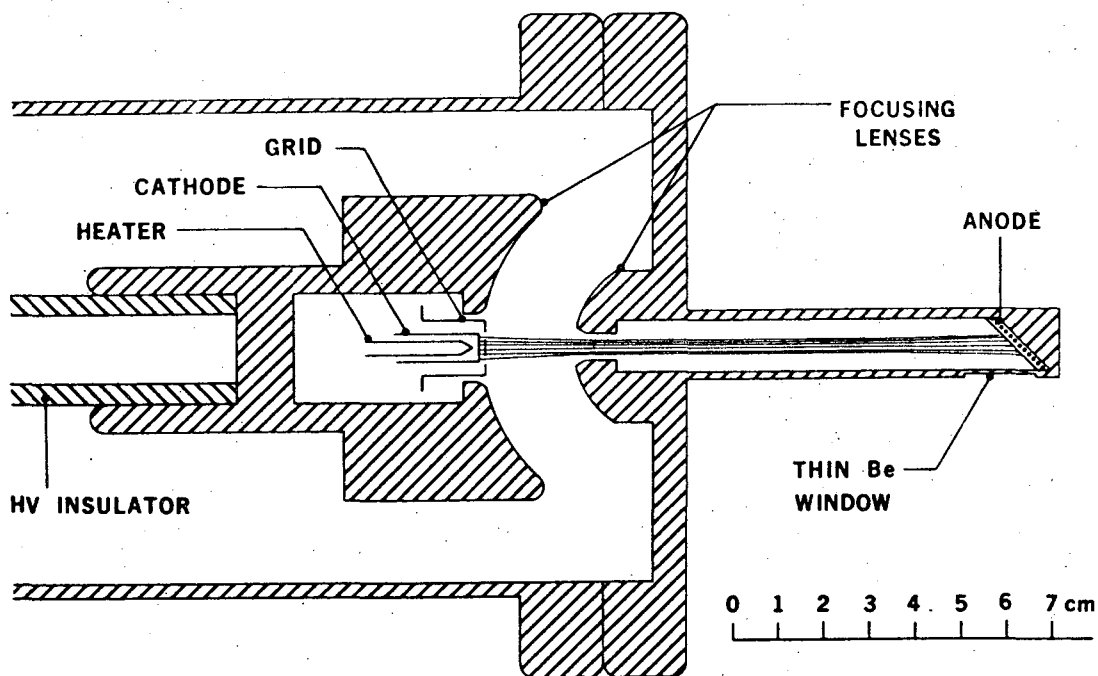

XBL 756-1687

Fig. 6. Diagram of pulsed X-ray tube.

The electron source is a standard cathode-grid assembly normally used in a commercial microwave triode. The lens design is chosen to provide the proper beam focusing characteristics while maintaining a low field at the grid. This is necessary to achieve grid control voltages of 100 V or less without the use of additional electrodes. The tube is designed to operate at voltages from 30 to 80 kV to accommodate the range of secondary targets used in the analysis system. Over the entire anode voltage range pulsed emission currents greater than 100 mA are achieved with a 10 V grid pulse operated at a variable bias of 0 to 50 V. Details of calculations and measurements involved in the tube design are given in Ref. (5).

The capacitance of the grid circuit, including a one meter long section of low-capacity X-ray cable, is approximately 700 pF. Driving this capacity through 10 V in less than 50 ns requires a current of 140 mA--a value easily accomplished with transistors. The drive cir-

cuits are mounted in the oil-filled high-voltage power supply. The control signals for the grid bias and drive pulse are transmitted into the high voltage terminal by light pulses across optical isolators. The grid bias is transmitted as a variable frequency square wave which is converted to a voltage in the grid drive circuit. The delay of the grid drive pulse (τ_1 in Fig. 1) was measured to be less than 200 ns. The value was found to be consistent with the pile-up probabilities of 5% measured in the final system.

RESULTS

The pulsed X-ray tube was adapted to an earlier design of excitation system using Ti, Mo and Tb as secondary fluorescers. This range of exciting energies allows the analysis of elements ranging from Al to Ba in the periodic table. The semiconductor spectrometer was a guard-ring type (6) with energy resolution of 185 eV at 5.9 keV using a Gaussian shaper peaking at 17 μ s (τ_p in Fig. 1). A pulsed-light feedback system was employed (7).

The control circuits were adjusted to correspond to this processing time of $\tau_d = 50 \mu$ s and a maximum duty factor corresponding to 10 μ s maximum pulse width. The minimum ON time setting was 4 μ s corresponding to 5% pile-up probability during the turn-off delay time. This corresponds to an instantaneous counting rate at the minimum duty cycle condition of 10^5 cts/sec. The maximum anode dissipation was 100 W when achieving the peak counting rate (20 kc/s) on samples whose mass exceeded 4 mg/cm².

Measurements have been made using a number of specimen types in order to verify the performance of the system. Measured detectability limits are shown in Fig. 7. These results represent the quantity of each element required to produce a number of counts in the characteristic peak equal to 3σ , where σ is the rms deviation in the number of counts in the background immediately beneath the peak. An analysis time of 100 sec is assumed. Results are given for two substrates corresponding to typical biological specimens (30 mg/cm²) and air pollution filters (5 mg/cm²). The dashed curves are the biological specimens and refer to the right hand scale; the solid curves were obtained with 5 mg/cm² membrane filters and are referred to the left hand scale.

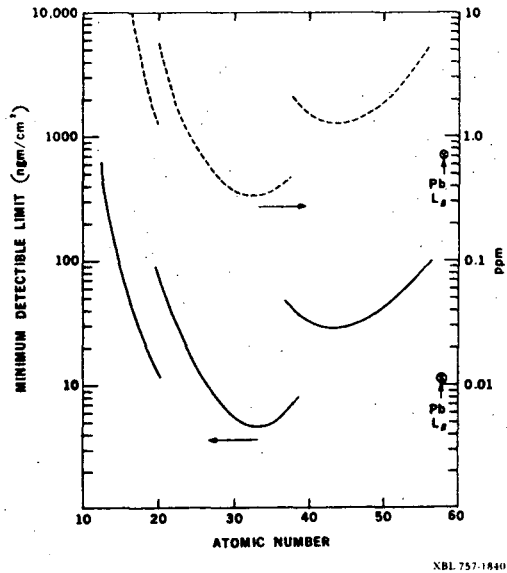

Fig. 7. Detectability limits using pulsed X-ray tube. The solid curves assume a 5 mg/cm^2 membrane type filter and refer to the left ordinate. The dashed curves assume a 30 mg/cm^2 biological specimen and refer to the right ordinate.

NBL 757-1840

ACKNOWLEDGMENTS

The authors would like to acknowledge the assistance of many fellow workers, especially B. Loo, W. Searles, A. Jue and N. Madden. D. Malone and J. Anderson contributed much to the mechanical design and assembly. We also thank R. Giaque for his assistance in calibrating the instrument.

REFERENCES

1. J. M. Jaklevic, F. S. Goulding and D. A. Landis, "High Rate X-ray Fluorescence Analysis by Pulsed Excitation", IEEE Trans. Nucl. Sci. NS-19, No. 3, 392-395 (1972).
2. H. Thiebeau, J. Stadel, W. Cline and T. A. Cahill, "On-Demand Beam Pulsing for an Accelerator", Nucl. Instr. and Methods 111 No. 3, 615-617 (1973).
3. P. J. Statham, G. White, J. V. P. Long and K. Kandiah, "Quantitative Analysis with an Energy-Dispersive Detector using a Pulsed Electron Probe and Active Signal Filtering", X-ray Spec., 3 No. 4, 153 (1974).
4. F. S. Goulding and J. M. Jaklevic, "Development of Air Particulate Monitoring Systems" EPA Environmental Monitoring Series Report # EPA-650/4-74-030 (1974).
5. F. S. Goulding, J. M. Jaklevic and B. W. Loo, "Fabrication of Monitoring System for Determining Mass and Composition of Aerosol as a Function of Time", EPA Technology Series Report # EPA-650/2-75-048 (1975). LBL Report UCID-3767.
6. J. M. Jaklevic and F. S. Goulding, "Semiconductor Detector X-ray Fluorescence Spectrometry Applied to Environmental and Biological Analysis" IEEE Trans. Nucl. Sci. NS-19, No. 3, 384-391 (1972).
7. D. A. Landis, F. S. Goulding and R. H. Pehl, "Pulsed Feedback Techniques for Semiconductor Detector Radiation Spectrometers", IEEE Trans. Nucl. Sci. NS-18, No. 1, 115-124 (1971).

LEGAL NOTICE

This report was prepared as an account of work sponsored by the United States Government. Neither the United States nor the United States Energy Research and Development Administration, nor any of their employees, nor any of their contractors, subcontractors, or their employees, makes any warranty, express or implied, or assumes any legal liability or responsibility for the accuracy, completeness or usefulness of any information, apparatus, product or process disclosed, or represents that its use would not infringe privately owned rights.

TECHNICAL INFORMATION DIVISION
LAWRENCE BERKELEY LABORATORY
UNIVERSITY OF CALIFORNIA
BERKELEY, CALIFORNIA 94720