

Lawrence Berkeley National Laboratory

Lawrence Berkeley National Laboratory

Title

QUASI-STATIC DRIFT-TUBE ACCELERATING STRUCTURES FOR LOW-SPEED HEAVY IONS

Permalink

<https://escholarship.org/uc/item/8v73j42w>

Author

Faltens, A.

Publication Date

1977-11-01

Quasi-Static Drift-Tube Accelerating Structures for Low-Speed Heavy Ions

A. Faltens and D. Keefe

Lawrence Berkeley Laboratory
University of California
Berkeley, California

NOTICE
This report was prepared as an account of work sponsored by the United States Government. Neither the United States nor the United States Department of Energy, nor any of their employees, nor any of their contractors, subcontractors, or their employees, makes any warranty, express or implied, or assumes any legal liability or responsibility for the accuracy, completeness or usefulness of any information, apparatus, product or process disclosed, or represents that its use would not infringe privately owned rights.

1. Introduction

One of the major problems in the application of a linear induction accelerator to Heavy Ion Fusion has been that of finding a suitable injector which could deliver of the order of 100 A for a few μsec within a normalized emittance of $\epsilon_N = 2 \times 10^{-5}$ radian-meters. At the 1976 HIF Summer Study, magnetically-insulated diodes and reflex triodes appeared to offer some promise, as they have delivered ion currents (protons) of hundreds of kiloamperes for $\sim 0.1 \mu\text{sec}$ at an energy of about 1 MeV. It soon became clear, however, that such currents could not be transported without neutralization and that further acceleration would be difficult with neutralization. In the past year the transport problem has been greatly clarified, and it seems that the desired 100 A of U^{+1} could be transported only at energies above ~ 70 MeV with 4 T superconducting magnets, and above 250 MeV with 1.1 T normal magnets. There is, of course, no sharp boundary in pulse length below which induction units do not work; rather, they become increasingly inefficient as the pulse duration increases and the beam current decreases; so it becomes desirable to look for alternative means of acceleration at the

very low energy end of the accelerator. The pulsed drift-tube accelerating structure described in this paper is one such alternative.

A pulsed drift-tube accelerating structure is shown in Fig. 1. Its gross characteristics are almost the opposite of those of induction units, in that its usefulness is limited almost entirely to low velocity ions and relatively long pulse duration. The accelerator is quasi-static in the sense that for slowly-varying voltages applied to the drift-tubes, all particles at a given axial position experience essentially the same voltage gain regardless of radius. The voltage of the drift-tube is switched when all of the beam bunch is within it, so that the beam moves as if going through a series of d.c. accelerating gaps. In contrast to an rf linac there is essentially no synchrotron oscillation motion nor instantaneous energy spread induced in the beam, although either or both may be intentionally generated if desired. The drift-tubes are driven by pulse-power modulator circuitry in a non-resonant mode which allows pulse shaping as desired.

2. Injector Needs for HIDE and Beyond

A possible approach to designing a 100 kJ Heavy Ion Demonstration Experiment (HIDE) as part of the heavy-ion fusion program has recently been suggested by Richter.¹ In this approach one would consider first how to provide for a 1 MJ, 100 TW facility (parameters that are close to what is needed for a pilot power-plant) and then forego the major accelerating device required therein; reducing the particle kinetic

energy by a factor of ten thus leads to a 100 kJ experiment with the capability of later expansion to the 1 MJ case. One much-discussed scenario for HIDE involves acceleration by means of rf linacs of about 100 particle micro-coulombs to an ion kinetic energy, $T \approx 1$ GeV, followed by accumulation and modest bunching in a small storage ring to a final pulse length of $\tau \approx 2$ μ sec, and finally injection into an induction linac section in which the beam is accelerated and strongly bunched. An apparent attraction of this scenario is that one gains experience in the use of both rf and pulsed non-resonant systems and models the behavior of an intense ion beam in a circular machine. Later upgrading to the 1 MJ, 100 TW capability would be accomplished by adding either a linac (rf or induction) or a synchrotron to raise the kinetic energy by an order of magnitude.

If the upgrade is visualized to take place by building a large induction linac, then injection of relatively few amperes at an energy as high as $qV_i \approx 1$ GeV, while viable, is not well-matched to the intrinsic properties of this type of machine (here q is the ion charge state, and V_i the beam "voltage"). It is the purpose of this report to discuss an alternative type of injector system, also based upon pulse-power technology, which is better matched to the induction linac properties. If we adhere to the arbitrarily-chosen value of 2 μ sec for the injected pulse-length required, τ_i , then a pulsed drift-tube structure with a total voltage in the 50-100 MV range could deliver the appropriate

injection current of 50-75 amps. We shall discuss several design features and design strategies for this system. It is not clear whether such an injector has application to other accelerator systems apart from the induction linac.

In discussing representative numerical examples we shall use parameters appropriate to the 1 MJ, 100 TW upgraded HIDE case (see Table 1).

In what follows we shall concentrate on explaining the general concept and discussing realistic physical and technical limitations imposed by the availability of voltage sources, electrical switches, pulse rise-times, etc. and by the need to avoid electrical resonances in the intended non-resonant structures. These limitations are stringent in some regards, and can demand use of certain strategies (e.g. parallel accelerators with later stacking) to achieve the design goals; some such strategies will be outlined.

To simplify the discussion we avoid certain design issues that must be faced and demonstrated to have good solutions. For example, (a) we assume that a pulsed (10 - 100 μ sec) high-voltage (2 MV) source with an anode area of 100-1000 cm^2 can deliver a current 1I_0 in the 1 to 5 ampere range with a suitable emittance; (b) we do not specify the transport system through the first few drift-tubes, say to the 5-10 MV point, and assume quadrupole transport from there on; and (c) the best strategy for obtaining charge state $q = 4$, should that be the

Table I. Parameters for an Induction Linac with the HIDE-Upgrade
(1 MJ, 100 TW) Capability*

Parameter	Symbol	1	4
Charge State	q	1	4
Final voltage	V_f	10 GV	6.5 GV
Final kinetic energy	T_f	10 GeV	26 GeV
Number of beams		2	2
Target radius	r	2 mm	1 mm
Current per beam**	I_f	5 kA	7.7 kA
Charge (electrical)	$^1[It]$	100 μ C	
Charge (electrical)	$^4[It]$		155 μ C
Pulse length at injection	τ_i	2 μ sec	2.1 μ sec
Current at injection [†]	I_i	50 amps	75 amps
Injection voltage [†]	V_i	115 MV	80 MV
Injection kinetic energy [†]	T_i	115 MeV	320 MeV

* Assumes $A = 238$ and a specific energy in a gold shell of 20 MJ/gm.

** Assumes pole tip field in final transport system can be 4 T and the magnets occupy 50% of the space. The normalized emittance is taken to be $\pi\epsilon_N = 2\pi \times 10^{-5}$ radian meters. The Laslett "figure-of-merit" is taken to be 0.93.²

† Assumes pole tip field of 1 T (and 50% occupancy factor) at injection point. If a pole tip field of 3 T is assumed then I_i can be doubled and the injector voltage decreased to less than half.

most desirable, is not specified. Any one of these points requires very careful study in itself; for instance, during the early stages of rapid acceleration the transport system will be different from the usual quadrupole lattice case and the transport system may require some grid focussing (of the type designed by Herrmannsfeldt³), followed by electrostatic quadrupoles and/or solenoids. This will be discussed in detail in another report.⁴ Careful design and experimental demonstration are needed to show that the appropriate emittance can be achieved and preserved.

3. Concept and Strategies

3.1 General Concept:

The idea of accelerating a bunch of charged particles through a drift-tube and changing the voltage while they are electrically hidden inside is an old one; the unusual features under discussion here simply involve the physical scale and the freedom to employ arbitrary pulse shapes. The drift-tubes needed are visualized to have a bore radius $A \sim 0.1 - 0.5$ m, a typical length, $D \sim 10 - 20$ m, and an applied high-voltage pulse (± 1 MV) from a pulse power source (to be discussed later).

The total number of drift-tubes required is on the order of fifty. A variety of systems using such elements is shown schematically in Fig. 1.

A long sausage-shaped bunch of charged particles is drawn from a gridded multi-aperture source (pulsed to 1 MV) into the initial drift tube (D_0 meters long) which first is pulsed to -1 MV, and later - when the bunch is hidden within - is pulsed

in reverse to +1 MV, to provide another increment of q MeV in energy upon exit. Referring to Fig. 1A it is seen that the same technique can be repeated in later drift-tubes, each of which has comparable length and similar voltages, but which can have decreasing aperture as the particle energy increases and the matched beam size decreases.

Depending on how one chooses the voltage pulse shapes three possibilities can be distinguished:

i) All drift-tubes have flat-topped voltages applied: In this case the front particle of the bunch gains energy before the last particle. Thus, the spatial length of the bunch grows in time in proportion to the bunch speed. Successive drift-tubes would need to be increased in length in similar proportion and very soon the needed structures would become unacceptably long. This case corresponds to $D \propto \sqrt{V}$ and the current, $I = \text{constant}$.

ii) As soon as convenient, e.g. between the first and second drift tubes, a specially shaped voltage pulse is applied across an inter-drift-tube-gap; thereafter all gaps have flat-topped voltage pulses: If the shaping-pulse rises from zero at the time of passage of the front particle to full value as the last particle crosses the gap a tilt of the momentum ellipse is created such that the spatial length of the bunch remains a constant even under acceleration by constant voltage at every succeeding gap. Thus the drift-tubes can be kept (roughly) constant in length with savings in the overall length of the injector. In this

case $D = \text{Constant}$, and the current increases along the structures as $I \propto \sqrt{V}$.

(iii) Following a shaping pulse of the type described, successive gaps provide not a flat-topped voltage pulse, but one that has a modest positive ramp: The momentum ellipse is therefore provided with a further small tilt at each accelerating gap, the bunch length in space becomes progressively shorter and the beam current increases faster than \sqrt{V} . From consideration of the transverse space-charge limit in a quadrupole system⁵ it can be shown that, in principle, the bunch length L can be compressed as fast as $L \propto V^{-1/3}$ and still remain within the space charge-limit. The drift-tube lengths, D , can thus be made shorter as the acceleration proceeds, but for practical reasons (see below) cannot be shortened in proportion to L .

The instantaneous energy spread created by the time-changing fields in the gap, $\Delta T(r) \approx -\frac{qer^2}{4c^2} \frac{d^2V}{dt^2}$, is negligible for the time-rates of change contemplated.

In what follows we adopt a sequence of voltage pulse shapes as described under (iii) above.

3.2 Arrangement of Suitable Components: Strategies

A numerical example best illustrates the range of possibilities that may have to be catered for. From Table I and assuming a 2 MV source, we derive that the initial bunch length needed is (for $q = 1$) $\frac{l}{l_0} = \frac{130}{1} \text{ m}$

where 1I_0 is the current at the source. (If an adequate current, denoted by 4I_0 , of charge state $q = 4$ could be drawn from a source - which is unlikely - then the initial bunch length would be $^4L_0 = 390/^4I_0$. Instead, the most likely strategy for obtaining charge state +4 is to extract some 150 μC of charge state +1 from the source, accelerate the bunch to about 10 MeV and pass it through a helium stripper to obtain the desired 155 μC of charge state +4 ions. The initial bunch length in this case would be $^4L_0 = 200/^1I_0$ meters.) If a source current, 1I_0 , of 5 amps can be obtained then $D_0 (\approx L_0)$ would be 26 m and close enough to the desirable range (10 - 20 m) to allow the single-pass system shown in Fig. 1a to be used. If, on the other hand, the current from the source were as low as $^1I_0 = 1$ amp then the drift-tube length implied, 130 m, is out of the question and some partitioning of the beam and/or structure into, say, six pieces is needed. The very long structure is undesirable because of its low acceleration rate and low electrical efficiency, and care must be taken to switch voltages sufficiently slowly to avoid exciting the electrical-line resonances or to damp them if excited.

The number of beam segments required thus is probably in the range of one to six, depending on where in the expected 1 - 5 amp range the achieved current value falls, and some strategies for segmenting and recombining the beam, therefore, merit discussion. On paper an attractive possibility is illustrated in Fig. 1b, which shows how multiple pulsing of the drift-tubes would allow a train of bunches

(just two shown) to be accelerated. Each bunch is separated by a drift-tube length from its neighbor. At the end of the injector the final drift-tubes are required to accelerate the successive bunches at differing rates so that the gaps between bunches close after a drift space. At that point (within the induction linac) the differential speeds can be removed by suitable pulsing of a number of cavities and a single long-bunch character restored. The drift length for recombination can be occupied by induction linac modules which can continue to provide energy to the particles as the bunches drift together. Note that in the example shown the voltage gradient (MV/m) of the structure is double that of a single bunch system. Practically, a small number of bunches is realizable, but the system becomes increasingly difficult as the number is increased much beyond two.

Because the pulsed drift-tube structure intrinsically has a low average gradient (~ 0.1 MV/m), the length and cost of the transport magnets (assumed dc superconducting) become of large concern. A scheme for utilizing a few drift-tubes over and over again by recirculating the bunch has been examined as a possibility (Fig. 1c). Low-field pulsed bending magnets are used to direct the bunch through a number of long drift-tubes surrounded by fixed-field quadrupole lenses. It was found possible to select a fixed-field focussing system such that beam motion was stable for an interesting number of revolutions (≥ 20) despite the changing energy and changing space-charge forces.⁶ A

recirculator would require injection at about $T = 10$ MeV but, thereafter, could provide enough energy to be followed immediately by an induction linac. This system, unfortunately, requires multiple pulsing of the drift-tubes with a variety of voltage wave-forms.

Figure 1d illustrates probably the most straightforward approach in which a number of drift-tube injectors are used in parallel and, at appropriate voltages determined by the space charge limits, the beam segments are stacked in transverse phase space. In principle, the four beams illustrated can be recombined with an emittance growth of only a factor of two in each plane; in practice, the strong space charge forces will probably cause some dilution. Recombination in longitudinal phase-space by drifting the bunches together, analogously to the scheme shown in Fig. 1b, is a possible option if desired. A useful property of the system shown, in which common modulators are used for each stage, is that all particles observe the same accelerating voltage history and undesirable effects due to power source fluctuations are minimized.

4. Influence of the Existing State of Component Technology on Drift-Tube Structure Design

4.1 General Considerations

The output voltage wave-form from a 1 MV pulse-power bi-polar modulator will have the general features displayed in Fig. 2. The rise-time is irrelevant and is followed by a time, τ_B , of suitable

voltage shape that is evident to the bunch, a time τ_{SW} which is the time required to change polarity before the voltage again becomes suitable for acceleration and, finally, a fall time which is irrelevant. Allowing for electric field penetration at both the drift-tube ends for a distance of roughly the bore radius, we note that the drift-tube length is given by

$$D = 2a + L + v\tau_{SW} .$$

The first term is small (≤ 1 m), the second can, by suitable ramping, be made to decrease with total voltage at a rate $L \propto L_0 V^{-1/3}$, while the last term increases as \sqrt{V} and is directly proportional to the switching time. The relative contributions of the different terms can be seen from Fig. 3 for cases with $q = 1$ and $q = 4$ and for two different switching times, $\tau_{SW} = 0.3 \mu\text{sec}$ and $3 \mu\text{sec}$. It is assumed that the initial bunch length, L_0 , is 20 m so that the first few drift-tubes will be somewhat longer than the desired upper range of 20 m, and that this length is appropriate for $V = 3$ MV for $q = 1$ ($T = 3$ MeV) and $q = 4$ ($T = 12$ MeV). It is clear from the figure that the compactness of the structure depends strongly on the switching time achievable. At a high enough ion-velocity, v , - possibly beyond the range of interest - to abandon bipolar-pulsing and retreat to a unipolar pulse with a rise time $\tau \approx 0.1 \mu\text{sec}$ can, paradoxically, lead to a higher-gradient structure.

4.2 Voltage Sources and Switches

It is obvious that, for a given structure and transport system, one should apply the highest voltage, ΔV , which the structure will tolerate. It is also necessary to do so in order to keep the average accelerating field, $\langle E_z \rangle = 2 \Delta V/D$ MV/m, high compared to the longitudinal self-fields of the bunch, $E_{zq} = \frac{30}{\beta} (1 + 2 \ln \frac{a}{b}) \frac{dI}{dz}$. The availability of reliable electrical components and switches places strong limitations on possible modulator choices. For example, we have assumed the use of reliable pulse power technology at the 1 MV level, but it needs to be verified that trustworthy insulators at suitable cost will be available; if not, the voltage choice may have to be decreased somewhat, at the expense of average gradient. As examples, we discuss four cases for modulator choices:

(i) An approach suitable for the early drift-tubes is illustrated in Fig. 4a; it involves a low-voltage (20-100 kV) lumped pulse forming network (PFN) switched by means of a thyatron to the primary of a step-up pulse transformer that delivers 1 MV at the secondary output. A particular example design is shown in some detail in Fig. 5. The parameters under consideration in this case do not exactly match those derived from Table I, but are not very different. The drift-tube is 12 m long, the beam current is 1-5 amps, and the total energy delivered to the beam is a few tens of joules. Note that in this system the stored energy in the pulse-line need only be a few kilojoules and about 80% of this energy can be recovered and re-stored in the line.

It can be seen from Fig. 3 that the utility of this approach is probably confined, for the examples considered, to the first 30 MV or so of the $q = 1$ case.

(ii) The next choice of modulator to be considered is represented in Fig. 4b. The unipolar Marx can have a rise time of $0.1 \mu\text{sec}$ and a similar crow-bar time, and could be pulsed either while the bunch enters or exits from the drift-tube. Modest ramping of the pulse or more subtle pulse-shaping can be achieved by low-voltage pulse-forming networks applied to the lowest decks of the Marx. This approach does not lend itself readily to energy recovery; at the few kilojoule level, however, this is probably not an important consideration.

(iii) An attractive choice for a modulator, illustrated in Fig. 4c, is a combination of two Marx generators with opposite polarities. Since the rise-time is not important in this case the first generator can power the load through a large resistor R_1 . When it becomes time to switch polarity the first generator is crow-barred and the second one activated through a series output spark-gap, and most of the open-circuit voltage is developed on the drift-tube load if the resistance R_1 is adequately large. The RC-limited switching time, τ_{SW} , will be of order $0.3 \mu\text{sec}$ in which case its influence on the drift-tube length is not important (see Fig. 3).

(iv) A combination of Marx generators with suitable de-coupling resistors (see Fig. 4d) can be arranged to provide multiple pulses to

a single drift-tube. A system for the two bi-polar pulses illustrated requires that $R_1 \gg R_2 \gg R_3 \gg R_4$ and it is obvious that extension to a significantly greater number of pulses rapidly becomes unreasonable.

In previous publications^{7,8} we have drawn attention to the special attraction of using pulse-power technology, in the form of the induction linac, for the acceleration of high-current beams, because of the capability of obtaining very high peak-power from an inherently low average-power source. Analogous arguments can be seen to hold for the pulsed drift-tube low-velocity structure discussed in this paper. Each drift-tube is used to supply only about 200 joules to the beam, but at a power level that varies from some 5 MW at the beginning of the injector to a healthy 100 MW at the end. The installed average power capability needed for acceleration alone should be significantly less than 1 MW.

At the same time we have adverted to the limitations imposed by the present state of development of this technology, particularly the narrow range of switches available.^{7,8} The strategies outlined earlier indicate that credible ways of circumventing these limitations can be constructed, but more elegant and less costly solutions would be possible if there were a wider variety of switches to choose from. For example, existence of a fast-opening switch would immediately allow a multiple-pulsing capability to an arbitrary degree (c.f. the system illustrated in Fig. 4d). Spark-gap switches provide a relatively low-cost method of switching at the 1 MW level, have satisfactory rise time and jitter, and at the power

values relevant to the present application can offer high reliability. Intrinsically, however, they have a long recovery time (>1 msec) and have to be regarded as one-shot devices on the time-scale of beam manipulation that concerns us here. Thyratrons, significantly more expensive (although cost on the scale of an injector which needs rather few elements is probably unimportant), have the attraction of a shorter dead-time, 10 μ sec or less, which is tantalizingly close to multiple-pulse exploitation in the earliest stages of a pulsed drift-tube accelerator. They are at present limited, however, to voltages of less than 200 kV and if used in combination with pulse-transformers to reach the 1 MV domain seem to have application only in the earliest stages of acceleration. The limitation which enters through the transformer is not due to the switch, but the need for voltage transformation. There are interesting new developments in vacuum-tube switch technology stimulated by the need for high-power series-regulator switches for neutral-beam sources for the Tokamak programs.⁹ Such tubes could approach the 10-100 MW pulse-power requirements with a switching-time that is negligible on the time-scale of present concern. The voltage capability of these tubes will be in the 150-200 kV range so that pulse transformer characteristics would still impose certain limitations. While we have not explored here the possible gains to be derived from the use of such switches their potential application should be examined further, especially in multiple pulsing of short drift-tubes without the use of pulse transformers.

5. Conclusions

The major attractions of the pulsed drift-tubes are that they are non-resonant structures and that they appear suitable for accelerating a very high current bunch at low energies. The mechanical tolerances of the non-resonant structure are very loose and the cost per meter should be low; the cost of the transport system is expected to be the major cost. The pulse power modulators used to drive the drift-tubes are inexpensive compared to r.f. sources with equivalent peak-power. The longitudinal emittance of the beam emerging from the structure could be extremely low.

6. Acknowledgments

We are particularly grateful to Dr. W. B. Herrmannsfeldt for his many valuable contributions to the drift-tube accelerator concept, and we thank our colleagues, G. Lambertson, L. J. Laslett, and L. Smith for their criticisms and discussions.

This work was supported by the U. S. Department of Energy.

References

1. B. Richter: Report in Proceedings of HIF Workshop at Brookhaven (Oct. 1977) to be published as a BNL report.
2. L. J. Laslett: Report in Proc. HIF Workshop at Brookhaven (Oct. 1977) to be published as a BNL report.
3. W. B. Herrmannsfeldt: unpublished calculations using the E-GUN computer code: see SLAC Report. 166.
4. W. B. Herrmannsfeldt, et. al., to be published.
5. See, for example: G. R. Lambertson, L. J. Laslett, and L. Smith, IEEE Trans. NS-24 993 (1977).
6. L. J. Laslett, and D. Keefe: unpublished (Nov. 1976).
7. A. Faltens, and D. Keefe: LBL-6453; to be published in Proc. Xth Int. Conf. on High-Energy Accelerators (Serpukhov, July 1977).
8. A. Faltens, D. Keefe, and D. L. Judd: LBL-6768; to be published in Proc. 2nd Int. Top. Conf. on High-Power Electron and Ion Beam Research and Technology (Cornell, October 1977).
9. Eimac Type X2209 and RCA Type A 3012 preliminary data.

Figure Captions

Fig. 1. Some possible arrangements of components in a pulsed drift-tube structure: (a) In-line arrangement of drift-tubes to each of which is applied a single bipolar pulse (for explanation of pulse shaping see text); (b) In-line arrangement where two pulses, in this example, are successively applied; the gradient (MV/m) is twice that of the former example; (c) Re-circulation through multiply-pulsed drift-tubes by means of pulsed bending magnets; (d) Inversely branched lay-out in which pulse stacking takes place (transverse stacking only, shown).

Fig. 2. Illustration of how the switching-time, τ_{SW} , affects the drift-tube length.

Fig. 3. The relative contribution of various parameters to the drift-tube length, D , as the beam voltage $V(= T/q)$ varies: (a) for $q = 1$, (b) for $q = 4$. Two values for $\tau_{SW} = 3 \mu\text{sec}$ and $0.3 \mu\text{sec}$ are indicated.

Fig. 4. Some pulse modulator choices: (a) Thyatron and pulse-transformer, (b) Unipolar Marx generator, (c) Bipolar Marx generator combination, (d) Double pulsing (Bi-polar) Marx Generator Combination. The natural RC droop of the Marx pulse can be removed and a positive ramp created by pulsing the lower decks.

Fig. 5. Example drift-tube and circuit to illustrate the approach outlined in Fig. 4a.

PULSED QUASISTATIC DRIFT TUBE INJECTOR (SOME EXAMPLE CONFIGURATIONS)

a.) Single Bipolar Pulse

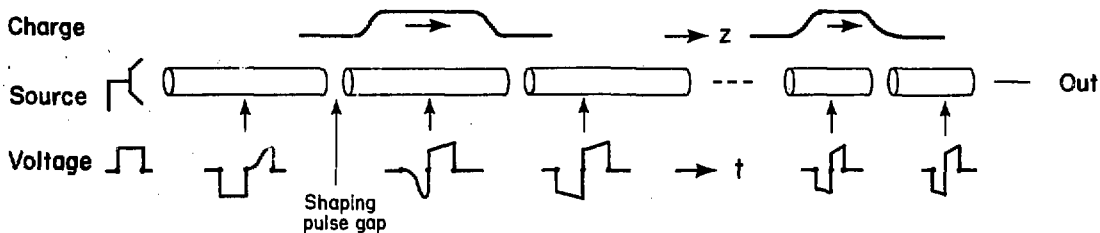

b.) Multiple (e.g. Two) Bipolar Pulse

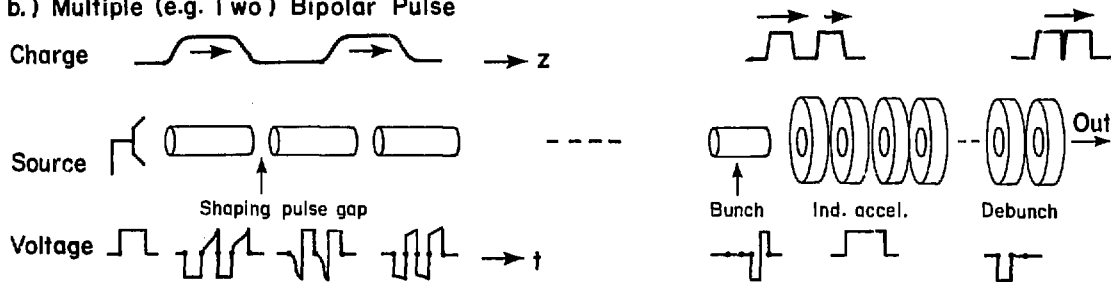

XBL 7711-11358

Figure 1

c.) Recirculation

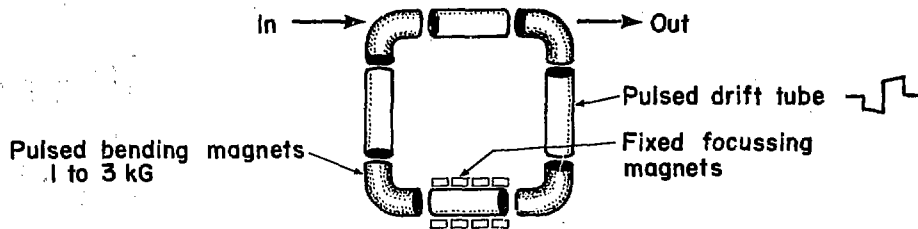

d.) Parallel Array (e.g. Four, with $\epsilon_H \rightarrow 2\epsilon_H$, $\epsilon_V \rightarrow 2\epsilon_V$)

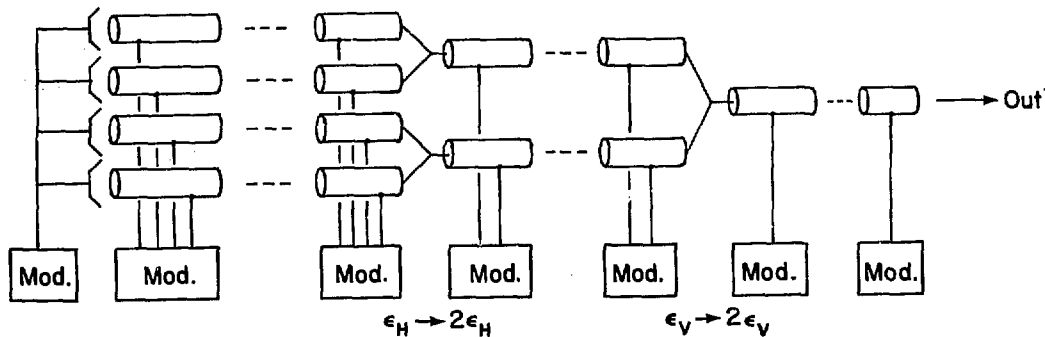

XBL 7711-11359

Figure 1 (cont.)

RELATIONS AMONG DRIFT-TUBE LENGTH AND BUNCH-LENGTH, RADIUS, AND SWITCHING TIME

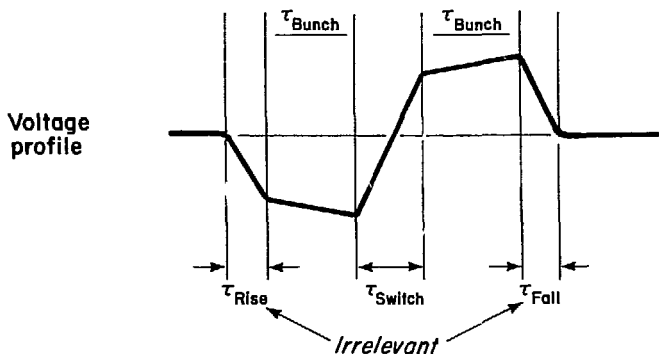

$$D = L_{\text{Bunch}} + 2a + v\tau_{\text{Switch}}$$

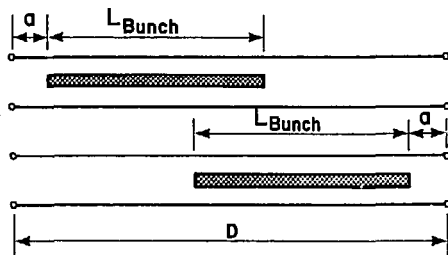

$t = t_0$

$t = t_0 + \tau_{\text{Switch}}$

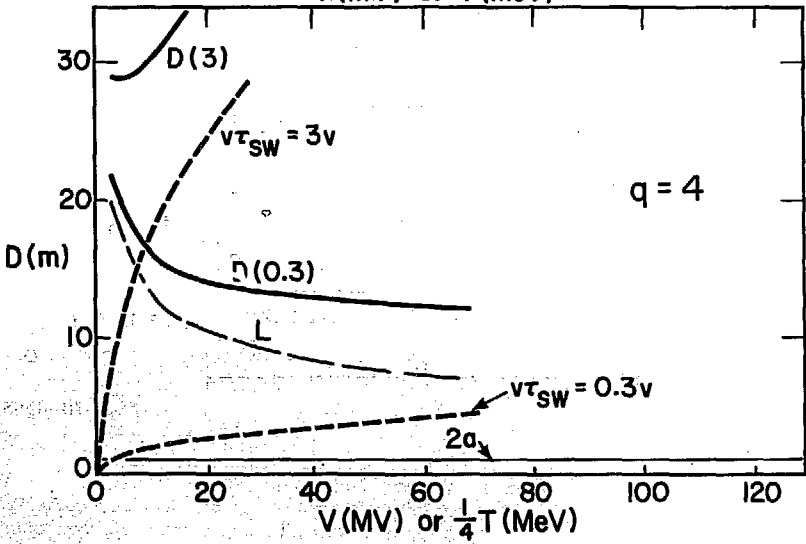
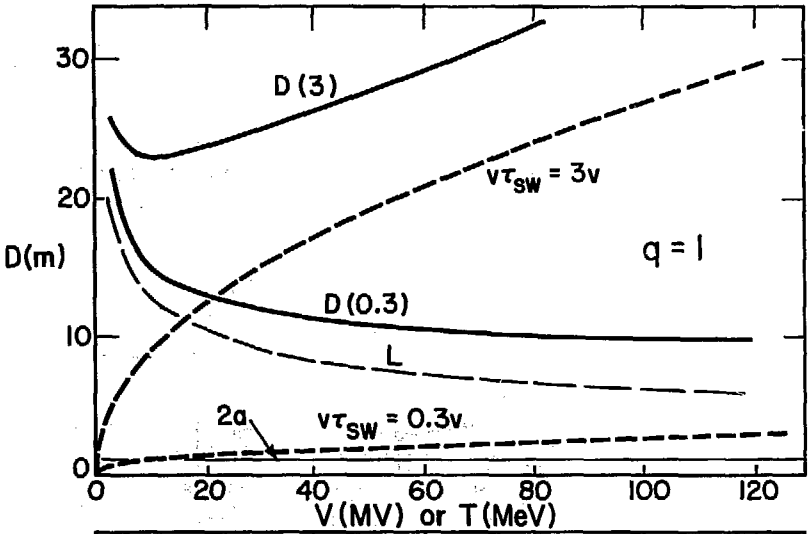

XBL 7711-11357

Figure 3

SOME VOLTAGE SOURCE OPTIONS

a.) Pulse Transformer

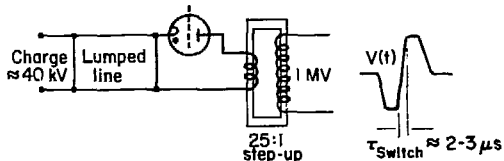

b.) Unipolar Marx (1 MV)

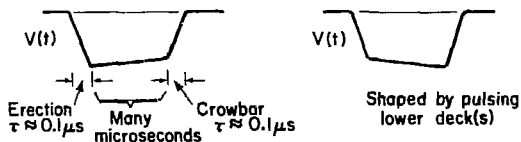

c.) Bipolar with Two Marxes (1 MV)

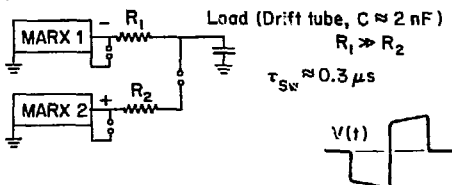

d.) Two Bipolar Pulses with Four Marxes (1 MV)

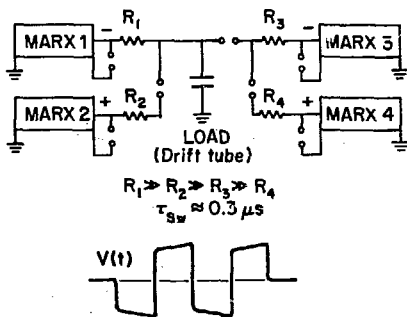

XBL 7711-11354

Figure 4

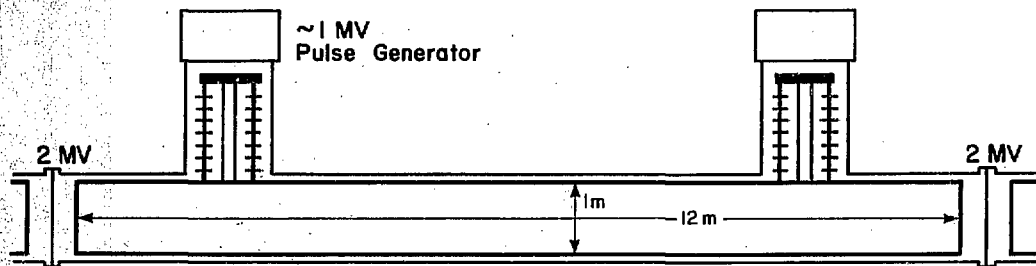

Pulse Modulator Circuit and Step-up Transformer

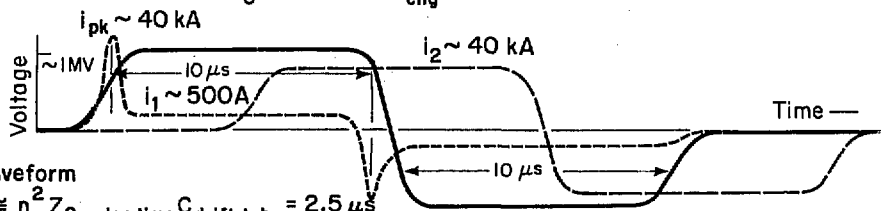
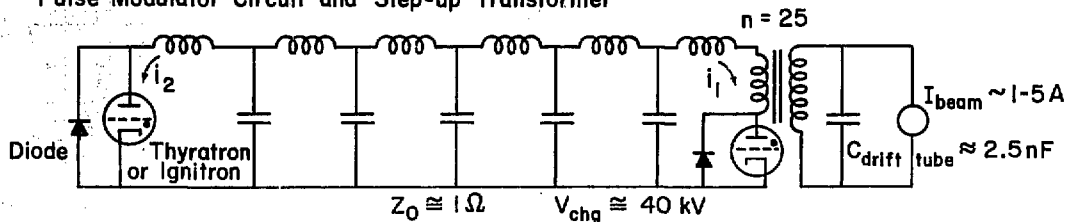

Output Waveform

$\tau_{\text{risetime}} \approx n^2 Z_0$ pulse time $C_{\text{drift tube}} = 2.5 \mu\text{s}$

XBL 7711-11356

Figure 5