

Lawrence Berkeley National Laboratory

Recent Work

Title

An Induction Linac Injector for Scaled Experiments

Permalink

<https://escholarship.org/uc/item/8zg5v2bb>

Authors

Rutkowski, H.L.

Faltens, A.

Pike, C.

et al.

Publication Date

1991-04-01



Lawrence Berkeley Laboratory

UNIVERSITY OF CALIFORNIA

Accelerator & Fusion Research Division

Presented at the IEEE Particle Accelerator Conference,
San Francisco, CA, May 6-9, 1991, and to
be published in the Proceedings

An Induction Linac Injector for Scaled Experiments

H.L. Rutkowski, A. Faltens, C. Pike, D. Brodzik,
R.M. Johnson, and D. Vanecek

April 1991

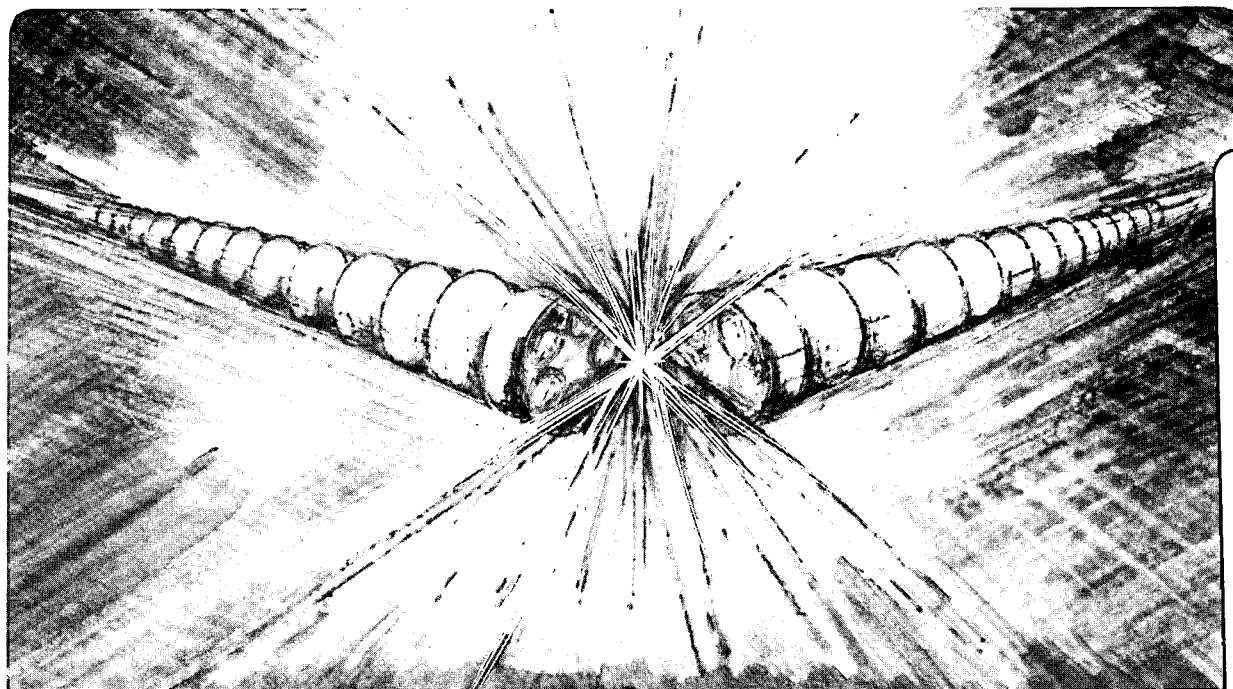

1 LOAN COPY 1
1 Circulates 1
1 for 4 weeks 1

Bldg. 50 Library.
Copy 2

LBL-30071

DISCLAIMER

This document was prepared as an account of work sponsored by the United States Government. While this document is believed to contain correct information, neither the United States Government nor any agency thereof, nor the Regents of the University of California, nor any of their employees, makes any warranty, express or implied, or assumes any legal responsibility for the accuracy, completeness, or usefulness of any information, apparatus, product, or process disclosed, or represents that its use would not infringe privately owned rights. Reference herein to any specific commercial product, process, or service by its trade name, trademark, manufacturer, or otherwise, does not necessarily constitute or imply its endorsement, recommendation, or favoring by the United States Government or any agency thereof, or the Regents of the University of California. The views and opinions of authors expressed herein do not necessarily state or reflect those of the United States Government or any agency thereof or the Regents of the University of California.

HIFAN-487
LBL-30071

An Induction Linac Injector for Scaled Experiments*

H.L. Rutkowski, A. Faltens, C. Pike, D. Brodzik, R.M. Johnson and D. Vanecek
Lawrence Berkeley Laboratory,
University of California
Berkeley, CA 94720

April 1991

This report has been reproduced directly from the best available copy.

- * Work supported by the Director, Office of Energy Research, Office of Basic Energy Sciences, Advanced Energy Projects Division, U.S. Department of Energy under Contract No. DE-AC03-76SF00098.

An Induction Linac Injector for Scaled Experiments*

H.L. Rutkowski, A. Faltens, C. Pike, D. Brodzik, R.M. Johnson, D. Vanecek, and D.W. Hewett**

Lawrence Berkeley Laboratory,
University of California
Berkeley, California 94720

ABSTRACT

An injector is being developed at LBL that would serve as the front end of a scaled induction linac accelerator technology experiment for heavy ion fusion. The ion mass being used is in the range 10-18. It is a multi-beam device intended to accelerate up to 2 MeV with 500 mA in each beam. The first half of the accelerating column has been built and experiments with one carbon beam are underway at the 1 MeV level.

I. INTRODUCTION

The Heavy Ion Fusion Accelerator Research program at LBL is planning to construct an experimental induction linac called ILSE [1] in order to study such phenomena as beam combining, bending of bunches with velocity tilt and pulse compression. In order to build this machine, a multi-beam injector providing ions in the mass range from carbon to potassium and with particle energy for a singly charged ion of about 2 MeV is required. An experimental injector is under construction, however as the ILSE design evolves, its design goals will also evolve. The original design called for sixteen two inch diameter beams providing up to 500 mA of C^+ ions per beam. The design normalized emittance per beam was $5 \times 10^{-7} \pi$ m-rad. The high voltage generator, ion source, control system, and the first half of the accelerating column have been constructed and beam experiments at the 1 MeV level are now occurring. We now discuss the existing system and future plans in terms of the three major components:

- a) High voltage pulse generator
- b) Ion source-extraction system
- c) Accelerating column.

II. HIGH VOLTAGE PULSE GENERATOR

This system is an unusual inductively loaded, gas insulated system designed for slow rise long pulse operation. The slow rise time is mandated by the fact that stray capacitances associated with the electrode structure in the column can cause voltage overshoot between gaps when a fast rise pulse is

applied. The Marx circuit is loaded by placing one inductor coil in series with the Marx discharge circuit at every other capacitor-spark gap stage. The self inductance of one coil is 18 mh. The full system consists of eighteen plastic trays each containing two capacitors and two spark gaps along with associated charging resistors. The trays hang from a pair of plastic impregnated wood beams inside the pressure vessel which can contain up to 80 psig. of SF_6 gas for insulation. Thus, the structure is modularized and individual trays can be removed for servicing. One coil is mounted around each tray. At the present time, a twelve tray system sufficient for use with the first half column is being used. The same system was used to fire into an open circuit in order to ring the discharge up to 2 MV for a dome-pressure vessel breakdown test. The proper loading of the inductive Marx circuit, to get the desired waveform, is provided by the resistor grading structure on the column itself. This resistor is a double-helix of Tygon tubing filled with conductive water. One leg of the helix runs from ground to the high voltage terminal. The other leg returns back to ground. The conductivity of the $NaSO_4$ -water solution in the resistor is controlled by a commercial unit at a level of 27,000 μS for the present configuration. According to circuit simulations, the present system is suited for operation as fast as one shot/5 sec. Normally we use it at 1 shot/10-12 sec for high voltage column conditioning and beam experiments. This rate matches the initial ILSE specification. The purpose of the slower rate is to allow additional pumping to occur inside the column.

One phenomenon observed in the Marx is a reduction of the resistance of the charge resistors with service. The charge resistors are nominally 40 k Ω carbon resistor 1.675" dia. x 12" long rated for 100 W service. These resistors were found to drop in resistance after service in the Marx. Controlled tests showed significant resistance drop when the resistors were subjected to 10 KV pulses of the same shape as the Marx pulse. There is a tendency for the resistance to drop to some asymptotic level after a few pulses and if the voltage of the pulse is increased, the resistance will drop to a new asymptotic level.

The specifications for the high voltage generator are likely to change toward faster rise time, if column stray capacitance will permit, and toward a longer flat voltage duration. Calculations are currently being done to determine if it is possible to reduce the rise time of the pulse applied to the column from the present 30 μsec to $\sim 5 \mu sec$. Finally, we are seeking to increase the rep rate capability of the system to

* Work supported by the Office of Energy Research, Office of Basic Energy Sciences, U.S. Department of Energy. Contract DE-AC03-76SF00098.

** Lawrence Livermore National Laboratory, P.O. Box 808, Livermore, CA 94550

1 Hz. Of course other factors affect the useable rep rate notably the pumping speed of the accelerating column.

III. ION SOURCE AND EXTRACTION SYSTEM

The ions source being used at present is a carbon vacuum arc in conjunction with an electrostatic plasma confinement device (plasma switch) to control emission optics during fast pulse extraction [2]. The carbon arc provides sufficient ion flux for our purposes ($>25 \text{ mA/cm}^2$) and in a single charge state [3]. Unfortunately the trigger that initiates the arc discharge does not last more than a few tens of thousands of shots. This is due to the fact that the trigger becomes coated with carbon over time and no remote cleaning technique has proved satisfactory for the long term. It is possible to change from a surface flashover trigger to a gas trigger [4] thus avoiding the carbon coating problem. However, there are other disadvantages to the source, mainly the noisy plasma from the cathode spot.

The ion source has been used together with the plasma switch in a pulsed extraction mode both in the injector itself and in a test stand. The plasma switch voltage is constant for these tests. The plasma switch allows one to extract quiescent beams from the source by electrostatically creating a planar virtual anode layer from which to extract ions. This means that the extraction system does not see the noisy streaming plasma from the cathode spot but rather a layer of ions captured by space charge forces near the plasma switch grid. This advantage of quiescent extraction is affected by the fact that the electric fields around the wires give transverse energy to the ions which ultimately becomes added emittance. Attempts have been made to circumvent this problem by reducing the plasma switch voltage during extraction as suggested by simulation results. The experimental result was that when the plasma switch voltage was reduced, oscillatory pulses were observed in the emittance measuring system and these pulses were not reproducible. Computer simulations were performed to determine whether or not the plasma drift velocity which was known to exceed the Bohm velocity by ~ 2 was responsible for this behavior. The simulations showed that the equilibrium near the switch changed but was not unstable. The most probable explanation for the beam noise is that making the plasma switch transparent by lowering its voltage causes the extractor to use the noisy streaming plasma emitted directly from the arc because the virtual anode layer is quickly destroyed when the plasma switch voltage is dropped. This technique for reducing grid induced emittance may still work if a quiescent plasma is available for the plasma switch.

If a quiescent plasma is available the switch would be used for D.C. shutoff of the plasma from the extraction gap. When the voltage is reduced extraction would occur from the plasma behind the switch. Simulation indicates that the extraction surface should remain very close to the switch grid thus preserving the geometry of the emission surface during pulsed extraction. We are presently constructing a 25 cm dia. cusp field source which would use RF power to generate neon ions. This source is capable of generating up to 10 cm dia. beams

which are of interest to the ILSE designers so that higher linear charge density can be generated in the beam. The gas will be admitted to the cusp chamber using a piezoelectric puff valve to reduce the acceleration column gas load. If, for some reason, the concept of reducing emittance generation by modulating the voltage on the plasma switch fails, the cusp field source would be usable for direct extraction of long pulses. If this approach is used, some way of selectively switching the output pulse of the injector must be found.

Meanwhile we continue to use the arc source-D.C. plasma switch combination for tests of the injector first half column. The inherent source emittance available is $2-2.5 \times 10^{-6} \pi \text{ m-rad}$. No further development of the arc source is anticipated because of the perceived advantages of the cusp field source in extending lifetime, use of inert gases, and plasma quiescence.

IV. ACCELERATING COLUMN

The first half of the accelerating column is designed for service at 944 KV. A drawing of the whole assembly complete with ion source and plasma switch is shown in Fig. 1. The cross hatched area represents the beam envelope as calculated with the EGUN [5] computer code for the case of 500 mA C^+ ions and full column voltage. The electrodes in the column are constructed of 6Al4V titanium. The ion source is located on the left. The plasma drifts from the arc cathode to the plasma switch which is operated at -55 V D.C. The 1 cm gap to the right is called the current valve. It is connected to a pulse line which pulses the source positively to inject a 1 μsec pulse into the column at the peak of the Marx voltage pulse. At the output end of the column a long tube (3") is biased at -3 kv with respect to ground to keep electrons generated by background gas ionization from entering the exit of the column and being accelerated toward the source.

The column has been operated to 10% above full design voltage without beam. In the beam extraction mode the column was first used for long pulse extraction directly from the source. For these experiments, the current valve was removed and the plasma switch grid was moved forward to the normal position of the current valve grid. The rest of the source assembly was moved forward by the same amount. The geometry makes it impossible to extract full current (500 mA) into the column and the EGUN predicted value is $\sim 300 \text{ mA}$ at full voltage. The measured current with a 4" diameter deep Faraday cup was 210-230 mA. Emittance measurements to study the optics of the beam were undertaken and the results were in good agreement with EGUN. The fact that such long current pulses at full column voltage could be transported reliably is very encouraging.

Experiments are now underway to use the current valve pulser to inject into the column. The voltage pulse is variable from 5-14 KV depending on the charge voltage of the pulse line. The voltage pulse remains unloaded by the presence of the source discharge and shows no pulse distortion. This behavior remains consistent for a full range of delays between the arc

discharge and the current valve pulse. Control of the delay is maintained when the injector is fired as is evidenced by fibre optic monitors of the in-dome pulsers.

Initial experiments with the large aperture Faraday cup revealed a slow leakage current following the Marx voltage pulse and a noisy pulse at the time of the current valve discharge. This was verified to not be electromagnetic noise. After trying many Faraday cup variations a fast response current transformer was installed at the beam exit which verified the final Faraday cup results that net electron current was exiting the column.

Experiments using a current transformer installed inside the column at the current valve exit verified that a noisy ion current pulse was entering the column. Increasing the rise time of the pulse from the initial 300 ns has showed an improvement trend. The current valve diode is 9.75 mm wide. Therefore a 300 ns rise time corresponds to several ion transit times across the gap at the design voltage of 13.6 KV for 500 mA of C^+ ions. The

rise time of the pulser had to be increased to 1.5 μ sec before a reasonably clean current pulse could be obtained. Tests using this new pulse shape are underway.

REFERENCES

- [1] Induction Linac Systems Experiments, Conceptual Engineering Design Study, Lawrence Berkeley Laboratory, March 1989, PUB-5219.
- [2] H.L. Rutkowski, R.M. Johnson, W.G. Greenway, M.A. Gross, D.W. Hewett, S. Humphries Jr., Review of Sci. Inst. 61, p. 553, January 1990.
- [3] S. Humphries Jr. and H. Rutkowski, J. Appl. Phys. 67, p. 3223, April 1, 1990.
- [4] S. Humphries Jr., private communication.
- [5] W.B. Herrmannsfeldt, Electron Trajectory Program, SLAC-226, November 1979.

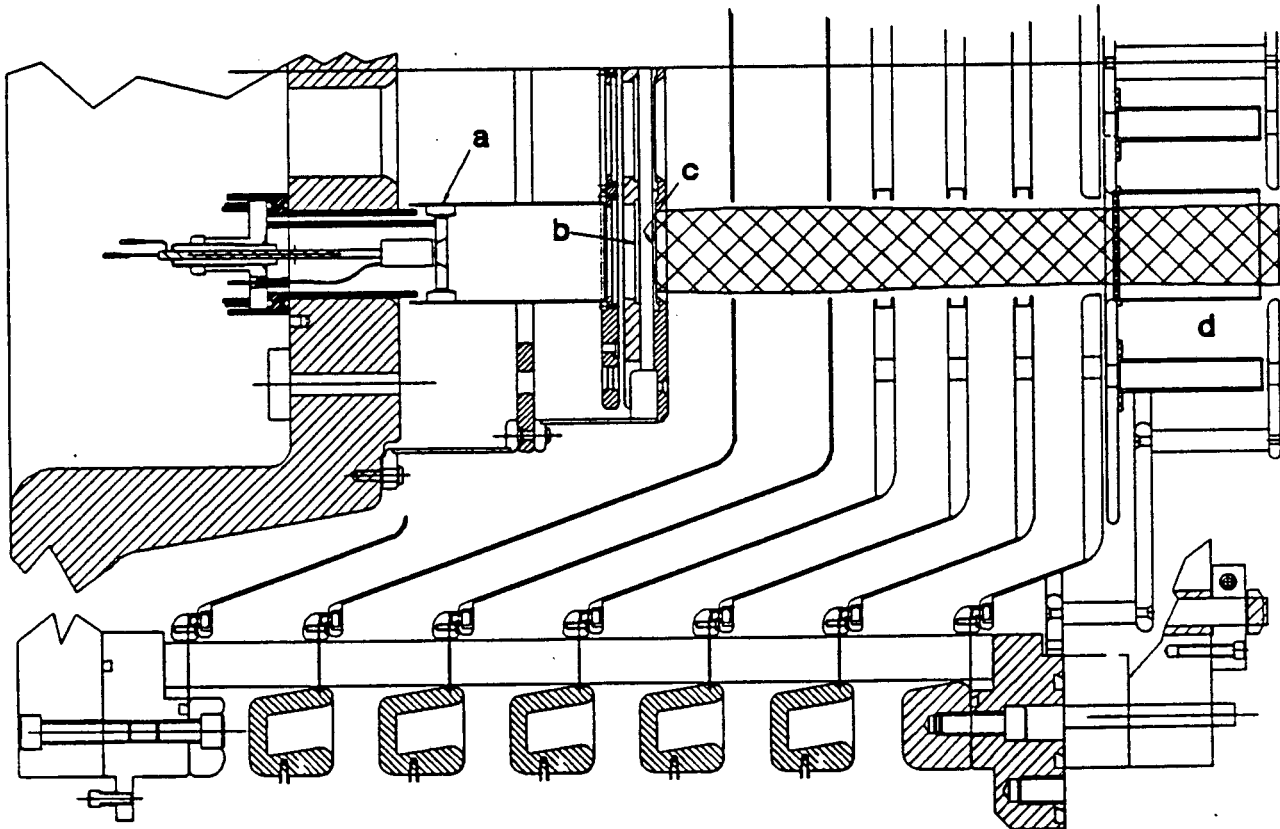

Fig. 1. First half of the full 2 MV injector accelerating column showing a) ion source, b) plasma switch grid, c) current valve grid, d) electron trap. Crosshatched area is calculated beam envelope for 500 mA, C^+ ions at full column voltage.

LAWRENCE BERKELEY LABORATORY
UNIVERSITY OF CALIFORNIA
INFORMATION RESOURCES DEPARTMENT
BERKELEY, CALIFORNIA 94720