

TOWARD A HISTORICAL TYPOLOGY OF KINSHIP-TERM SYSTEMS: THE CROW AND OMAHA TYPES

Vladimir A. Popov
St. Petersburg Scientific Center of the Russian Academy of Sciences
Institute of Oriental Manuscripts of the Russian Academy of Sciences
St. Petersburg
Russia
Email: popoffvladimir@gmail.com

Translated by Anastasia Kalyuta
Research Fellow
Saint Petersburg Institute of History of the Russian Academy of Sciences
St. Petersburg
Russia

(minor editing by Peter Whiteley)

Original English abstract:

An attempt is made to determine the place held by the Crow and Omaha types in the historical typology of systems of kinship terms. Attention is centred upon structural differences between individual systems within each of these types. The author groups all these differences into six variants and advances the view that they should be considered as stages in the development of the Crow and Omaha systems. All the variants are mapped. Two suppositions are made to explain the preservation of the peculiarities of the Crow and Omaha systems in the earliest phase of the secondary stage in the evolution of kinship systems. The author regards it as the more probable explanation that certain features of these systems survive from the preceding stage of development in the course of evolution. However, another possibility should not be dismissed, namely that in the course of evolution the terminology of the Crow and Omaha types acquires a novel content and, in fact, represents a combination of the same elements but possessing a new quality.

The author also emphasizes that to attach the names of types within the general typology of kinship term systems to particular ethnicities is unwarranted. This is especially true since these types are identified on the base of two structure-forming characteristics: bifurcation and linearity. Taking this into consideration the author proposes that the types should be named by terms denoting these characteristics.

Elaborating the typology of kinship-term systems (KTS) and research on historical relationships among kinship terminology types is one of the most important subjects of social anthropology. In recent years, research on typology has become one of the main topics in studies of kinship systems. New methods of structural analysis have been created and old ones improved; the transformation mechanisms of various types of KTS are being studied. However, many aspects of this subject remain unclear and require further study. In this regard, identifying the place of the Crow and Omaha types in a historical typology of KTS is of considerable importance.

Most existing KTS classifications are based on two main principles, first distinguished by L.H. Morgan:

- 1) merging/distinction of lineal and collateral relationships
- 2) merging/ distinction of paternal and maternal lines.

Almost all researchers have based their typologies on combinations of kinship terms for relatives of the first ascending (G+1) and Ego's generation (G0), applying both these main principles. In G+1 the following types of merging and distinction are marked:¹

| | | |
|-----|---|---|
| I | [P _M = Д _M PP _M = Д _M PP _Ж]; | [P _Ж = Д _Ж PP _Ж = Д _Ж PP _M] |
| | [F = FB = MB]; | [M = MZ = FZ] |
| II | P _M ≠ Д _M PP _M ≠ Д _M PP _Ж ; | P _Ж ≠ Д _Ж PP _Ж ≠ Д _Ж PP _M |
| | F ≠ FB ≠ MB; | M ≠ MZ ≠ FZ |
| III | [P _M = Д _M PP _M] ≠ Д _M PP _Ж ; | [P _Ж = Д _Ж PP _Ж] ≠ Д _Ж PP _M |
| | [F = FB] ≠ MB; | [M = MZ] ≠ FZ |
| IV | P _M ≠ [Д _M PP _M = Д _M PP _Ж]; | P _Ж ≠ [Д _Ж PP _Ж = Д _Ж PP _M] |
| | F ≠ [FB = MB]; | M ≠ [MZ = FZ] |

Various authors designate these four types of KTS by different names. Correspondences among these names in the most widespread typologies are shown in the following table.²

¹ Translator's and editor's note. Popov uses a formalist code devised by Yuri I. Levin (1970, On the Description of Systems of Kinship Terms, *Soviet Ethnography* 4:18, 19 [Ю.И. Левин, Об описании системы терминов родства, Советская этнография 4]), in which Cyrillic P (roman R), from родитель, stands for "parent" and Д, from дитя, stands for "child," with gender indicated by lower-case м (male) and ж (female). So, P_M = father, P_Ж = mother, Д_M = son, Д_Ж = daughter. The inverse of Western notation, sequences go left to right from alter to Ego. When P appears after Д it means "parents," and in other positions just "parent"; further, "the combination ДP means "the child of Ego's parents who does not coincide with Ego," i.e., sibling" (op. cit., p. 18). So, Д_MP = brother, Д_ЖP = sister. Cousins (undifferentiated) are represented as ДДPP, "child of parent's sibling" (ibid.). The alter-to-Ego sequence may be shown, for example, in ДД_MД_ЖPP_M, which literally means "child of son of sister of father" or in standard English notation, FZSC, father's sister's son's child. Levin's code was responsive to contemporary componential analysis (e.g., by Lounsbury, Goodenough, and Hammel) in the U.S. (ibid.). Other formalist notations focusing on P-C (Parent-Child) reciprocals encountered problems with gender, particularly to represent linking terms among relatives (see D.B. Kronenfeld, Editor's Introduction to S. Gould, 2000, *A New System for the Formal Analysis of Kinship*, pp. xxxii-xxxiv, Washington, D.C.). Levin solved that problem with the positional lower-case gender markers and situational variation of Cyrillic P as plural or singular. For historical and analytical purposes, the Levin- code strings used by Popov are retained here, but as most Anglophone readers will not recognize these, standard English notations are juxtaposed (F – father, M – mother, B – brother, Z – sister, P – parent, Sb – sibling, C – child).

² See M.B. Крюков. Система родства китайцев. М., 1972, с. 39. [M.V. Kryukov, 1972, *The Chinese Kinship System*. Moscow.]

| | | | | |
|-----------|---------------------|----------------------|----------|-----------|
| KTS Types | Morgan | Lowie | Rivers | Kirchhoff |
| I | Malayan | Generational | Hawaiian | C |
| II | — | Bifurcate-collateral | Kindred | A |
| III | Ganowanian-Turanian | Bifurcate-merging | Clan | B |
| IV | Aryan (descriptive) | Lineal | Family | D |

G.P. Murdock Improved the KTS typology suggested by L. Spier³ on the basis of groupings among G0 relatives—Ego’s cousins and siblings.⁴ In G0, the following variants of merging and distinction are marked:⁵

- I [X = II = Λ] — Hawaiian;
- II X ≠ II ≠ Λ — Sudanese, Murngin;⁶
- III [X = II] ≠ Λ — Eskimo;
- IV X ≠ [II = Λ] — Iroquois, Crow, Omaha.⁷

The typologies of G. Dole⁸ and M.V. Kryukov⁹ reflect combinations of groups of relatives in two generations (G+1 and G0). Kryukov united the traditional typology based on G+1 with Murdock’s typology (based on G0) and offered his own names for types:

| | | |
|-----|-----|-----------------------|
| G+1 | G0 | Kryukov |
| I | I | Hawaiian (Malayan) |
| II | II | Arabic |
| III | IV | Iroquois (Australian) |
| IV | III | English |

Kryukov’s historical typology has already [i.e., in 1977] received recognition in the Soviet ethnographic literature, but in our opinion his nomenclature for these types is flawed, because each type is associated with a particular ethnic group. It should also be remembered that initially the

³ L. Spier, 1925, The distribution of kinship systems in North America. *University of Washington Publications in Anthropology*, 1925, vol. 1, no. 2.

⁴ G.P. Murdock, 1949, *Social Structure*. New York.

⁵ X - cross cousins, children of father’s sister and mother’s brother (ДДжРРМ = ДДМРРж) [FZC = MBC]
 II - parallel cousins, children of father’s brother and mother’s sister (ДДМРРМ = ДДжРРж) [FBC = MZC]
 Λ - siblings, Ego’s brothers and sisters (ДМР = ДжР) [B = Z]

⁶ In the Murngin type patrilineal and matrilineal cross-cousins are designated by different terms:
 ДДжРРМ ≠ ДДМРРж [FZC ≠ MBC].

⁷ Murdock also distinguished the Buryat type in which FZC and FBC are grouped and designated by the same terms, while MZC are grouped with MBC, and with both groups of cousins terminologically distinguished from Ego’s siblings:

$$[ДДжРРМ = ДДМРРМ] \neq [ДДжРРж = ДДМРРж] \neq ДР$$

$$[FZC = FBC] \neq [MZC = MBC] \neq Sb$$

⁸ G. Dole, 1957, The development of patterns of kinship nomenclature. Ph.D. diss., U. Michigan, Ann Arbor.

⁹ Kryukov op. cit. [see footnote 2 above], pp. 39, 40.

Arabic type was called Chinese.¹⁰ Describing transformations of the Chinese KTS,¹¹ Kryukov replaced the name, seeking to avoid confusion obviously, as the Chinese KTS evolved from the Australian type to the Chinese (Arabic) type. However, the researcher of Arabic or English KTS can really face similar difficulties. The principle of elaborating typology to designate KTS types on the basis of structural characteristics seems more effective. As all four types of KTS are distinguished by two structure-forming characteristics, those characteristics with the maximal taxonomic relevance should be how KTS types are named.

Designating the distinction of lineal and collateral relatives by the term “linearity”¹² and the distinction of paternal and maternal kin by “bifurcation,”¹³ all the main types of KTS can be described simultaneously, indicating the key formative structural characteristics of each type. Here I use the effective schema suggested by Kryukov¹⁴ to illustrate (Fig.1):

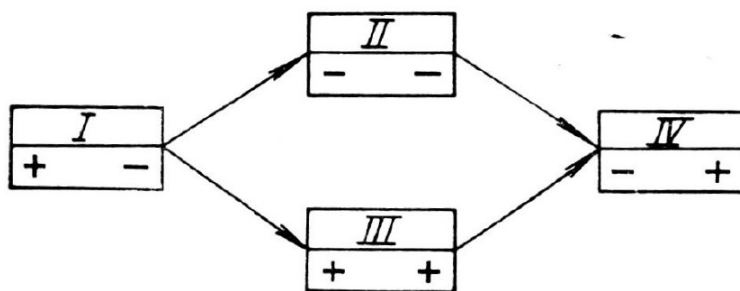

Fig. 1

Because bifurcation is the diagnostic feature of Type I (Iroquois), it can be named the Bifurcate type; Type III (Arabic) can be designated the Bifurcate-Lineal and Type IV (English) the Lineal, respectively. As Type II (Hawaiian) lacks both features, they cannot be used to designate the type. However, the specific feature of this KTS is distinction of relatives by generation, therefore, Type II can be named the Generational type.

Every comparison requires a main unit of measurement or a concrete criterion of evaluation—an etalon [a standard of measurement in physics] to be used as a starting point to describe and characterize a phenomenon in regard to its typological specifics. It is worth emphasizing that such an etalon is always present in every comparison between two KTS (in most

¹⁰М.В. Крюков. Типы систем родства и их историческое значение.—“Проблемы докапиталистических обществ”. М., 1968, с. 371. [M.V. Kryukov, 1968, Types of kinship systems and their historical significance. *Problems of Pre-capitalist Societies*, p. 371. Moscow.]

¹¹ Kryukov op. cit, 1968, Types of kinship systems.]

¹² Kryukov uses the term ‘linearity’ in this sense. See his *Chinese Kinship System*, pp. 107, 111, 126; and his “Эволюция систем родства: механизм трансформации”. М., 1973, с. 4 [Kryukov 1973, *The Evolution of Kinship Systems: the Mechanism of Transformation*. Moscow.]

¹³ Bifurcation (from Latin ‘bifurcation,’ “split”, “branching”) is a biological term introduced into anthropology by R. Lowie. It is used in Soviet ethnography (see, e.g., Л.В. Маркова. Трансформация южнославянской системы родства и ее соотношение с семейно-родственной структурой. М., 1973, с. 8). [L.V. Markova, 1973, *Transformation of the South Slavic kinship system and its relationship with the family-kinship structure*, p. 8. Moscow.]

¹⁴ Kryukov *Chinese Kinship System*, p. 65. Presence/absence of bifurcation and linearity are designated by + and -.

cases it is the KTS used by the researcher).¹⁵ The code of Yu. I. Levin¹⁶ seems to be the most logical and scientifically founded etalon — a meta-language in which every KTS can be described symbolically thus avoiding the main contradictions in descriptions of kinship nomenclature, where the terms of one system are described in the terms of another.¹⁷ The code is based on a genealogical matrix reflecting biological kinship relations.

Considering the KTS types as “scientific abstractions constructed on the basis of specific principles for combination of relevant features”¹⁸—i.e., an ideal model created by the researcher¹⁹—the particular type of KTS can be regarded as an etalon of another level with respect to Levin’s code. In this way, the general typology of KTS, which is a series of types mutually connected by strictly determined relations reflecting the historical evolution of KTS, can itself be considered an etalon. In most cases identification of an empirical KTS with a particular type is conventional and arbitrary to a certain degree, because no system completely coincides with an etalon type by all criteria. In order to place a particular KTS in a general KTS typology, it is necessary to elucidate all the system’s structural characteristics, establish their hierarchy, and after detecting the main ones, compare them with the characteristics on which basis the etalon types are constructed.

* * *

Let us consider the Crow and Omaha systems. The peculiarity of these KTS is the specific classification of cross-cousins and their descendants. With respect to the grouping of relatives of the 0 generation the Crow and Omaha systems are bifurcate; siblings and parallel-cousins are designated by the one common term and cross-cousins are called by different terms ($X \neq [II = \Lambda]$)²⁰). The main difference from other bifurcate KTS is absence of particular terms for cross-cousins because this category of relatives is placed with adjacent generations, either ascending ($\geq G+1$) or descending ($\leq G-1$), and is designated by terms from these generations. This phenomenon is called generational skewing. In Omaha systems the matrilineal cross-cousins and their descendants are considered to be relatives of ascending generations ($D^{\neq 1} D_{MPPJ} \geq +1$ [descendants of MB are raised to $G+1$]), while patrilineal cross-cousins and their descendants belong to descending generations ($D^{\neq 1} D_{JPPM} \leq -1$ [descendants of FZ are lowered to $G-1$]) (Fig. 2). In Crow systems the situation is

¹⁵ Н.М. Гиренко. Система терминов родства и система социальных категорий. — “Советская этнография”, 1974, № 6, с. 45. [N.M. Girenko, 1974, The system of kinship terms and the system of social categories, *Soviet Ethnography* 6, p. 45.]

¹⁶ See М.А. Членов, Формальные методы изучения систем родства в современной американской этнографии.— “Этнологические исследования за рубежом”. М., 1973, с. 168. [M.A. Chlenov, 1973, Formal Methods for Studying Kinship Systems in Contemporary American Ethnography, *Ethnological Research Abroad*, p. 168. Moscow.]

¹⁷ С.А. Токарев. К вопросу о методике изучения терминологии родства. — “Вестник МГУ, историко-филологическая серия”, 1958, № 4, с. 189-194. [S.A. Tokarev, 1958, On the question of the method of studying the terminology of kinship, *Bulletin of Moscow State University, Historical and Philological Series* 4, pp. 189-194.]

¹⁸ С.А. Токарев. К вопросу о методике изучения терминологии родства. — “Вестник МГУ, историко-филологическая серия”, 1958, № 4, с. 189-194. [S.A. Tokarev, 1958, On the question of the method of studying the terminology of kinship, *Bulletin of Moscow State University, Historical and Philological Series* 4, pp. 189-194.]

¹⁹ Kryukov *Chinese Kinship System*, p. 222; Kryukov *Evolution of Kinship Systems*, p. 1.

²⁰ Bifurcate-lineal features are observed in G0 (Ego’s generation) in some Crow and Omaha systems ($X \neq II \neq \Lambda$).

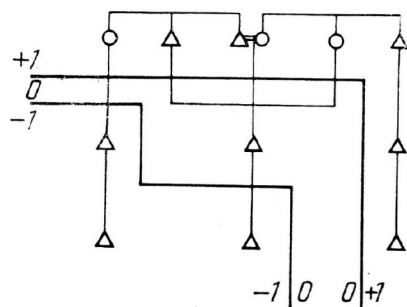

Fig. 2 Omaha type

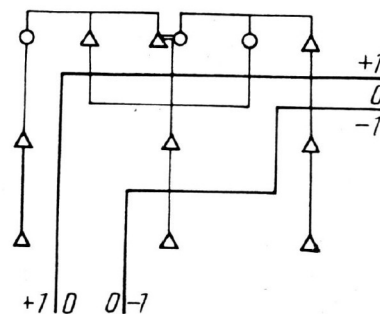

Fig. 3 Crow type

opposite: $\mathbb{D}^{\pm 1}\mathbb{D}_{\text{MPPЖ}} \leq -1$ [type descendants of MB are lowered to G-1]; $\mathbb{D}^{\pm 1}\mathbb{D}_{\text{ЖPPМ}} \geq +1$ [descendants of FZ are raised to G+1] (Fig. 3).

The terms ‘Crow’ and ‘Omaha’ were suggested by the American ethnologist L. Spier who in 1925 published a summary of new materials on the kinship systems of North American Indians and arranged all these systems into several types distinguished on the basis of groupings in G0. Each type was named after the ethnonym of the tribe in which its characteristic features were discovered.²¹ Crow and Omaha are two Native North American tribes belonging to the Hokan-Siouan language family. Omaha in literal translation means “the upstream people.” In the nineteenth century they inhabited the Missouri Valley. The Crow tribe was named after their totem — crow.* [*The name’s origin is more complex: see D.R. Parks, 2001, “Synonymy,” in F.W. Voget, “Crow” in *Handbook of North American Indians, Plains*, vol. 13, part 2, edited by R.J. DeMallie, pp. 714-716. Washington, D.C.: Smithsonian Institution (PW).] The Crow’s autonym is Absaroka, and their traditional territory lies in the modern states of Montana and Wyoming.²² Careful description of the Omaha KTS was made by J. Dorsey;²³ the Crow KTS was studied by R. Lowie.²⁴

The Crow and Omaha types are similar. In fact, the main difference between them consists in the specifics of generational skewing, in which the direction depends on filiation. Crow systems are predominantly found in matrilineal societies, Omaha systems in patrilineal. According to calculations by R. McKinley, 85.7% of all Crow KTS correlate with matrilineal descent, 89% of all Omaha KTS with patrilineal descent.²⁵

Because Crow and Omaha systems are mutually opposite in their structure, being a sort of mirror reflection of each other²⁶ (see Figs. 2, 3) in specialist literature they are usually united in one type: Crow-Omaha. W. Shapiro suggested naming this type “Pomo” as both Crow and Omaha

²¹ Bifurcate-lineal features are observed in G0 (Ego’s generation) in some Crow and Omaha systems ($X \neq \text{II} \neq \Lambda$).

²² L.H. Morgan, 1871, *Systems of consanguinity and affinity of the human family*, pp. 178, 185, 284-285. Washington, D.C.

²³ J.O. Dorsey, 1884, *Omaha sociology*. Washington, D.C.

²⁴ R.H. Lowie, 1912, Social life of the Crow Indians, *Anthropological Papers of the American Museum of National History* vol. 9, no. 2; and his *The Crow Indians*, 1935. New York.

²⁵ R. McKinley, 1971, A critique of the reflectionist theory of kinship terminology: the Crow-Omaha case. *Man* 6:2:231.

²⁶ In the natural sciences analogous phenomena are referred to by the term ‘chirality.’ In my opinion this term is convenient also to designate anthropological phenomena which are identical in their essence but at the same time have opposite symmetric forms of exterior manifestation.

KTS are found among various groups of Californian Pomo Indians.²⁷ However, this suggestion did not gain support.

The problem of Crow and Omaha KTS, which is usually understood as the problem of social determination of generation skewing, with the direction of skewing dependent on descent, has been the subject of constant discussion for many decades. C. Lévi-Strauss considers it to be one of the problems that hinder advancement of kinship studies²⁸ and American ethnologists say: “Solve the Crow and Omaha systems, and all the rest of the systems will be simple.”²⁹

Studies of Crow and Omaha KTS begin with L. H. Morgan’s *Systems of Consanguinity and Affinity of the Human Family*. In his survey of “Ganowanian” kinship nomenclatures among the North American Indians, Morgan was the first to pay attention to the fact that cross-cousins are regarded as relatives of ascending or descending generations among some Algonquian and Siouan tribes. Morgan did not provide any explanation for such merging of generations, he only described and noted that this peculiarity distinguished these systems from Iroquois — the typical Ganowanian-Turanian system.³⁰ For a long time, such systems were regarded as anomalous; when mentioning them such epithets as “strange”, “atypical”, “exotic” were usually applied, and as a rule they were associated only with some tribes of North American Indians. However, in the late nineteenth and early twentieth centuries similar systems were found among many peoples in various parts of world, and it became evident, after the works of R. Lowie³¹ and L. Spier,³² that Crow and Omaha are particular kinship-system types requiring explanation.

All researchers of the Crow-Omaha problem can be rather precisely divided into two categories: ethnologists and linguistic anthropologists. The first predominantly studied the conditions and factors that determine the appearance of generational skewing in these KTS.³³

²⁷ W. Shapiro, 1966, On the classification of bifurcate merging systems. *Anthropologica* 8:1:147, 148.

²⁸ C. Lévi-Strauss, 1966, The future of kinship studies. *Proceedings of the Royal Anthropological Institute*, 1965, p. 18.

²⁹ I. R. Buchler, H. A. Selby, 1968, *Kinship and social organization: an introduction to theory and method*, p. 276. New York.

³⁰ Morgan op. cit., pp.179, 188, 189, 191, 197, 198, 217, 262.

³¹ R.H. Lowie, 1917, *Culture and ethnology*. New York; 1930, The Omaha and Crow kinship terminologies, *Proceedings of the International Congress of Americanists*, Hamburg.

³² Spier op. cit.

³³ J. Kohler, 1897, Zur Urgeschichte der Ehe, *Zeitschrift für Vergleichende Rechtswissenschaft* no. 12; see the review of Kohler’s book by E. Durkheim in *Année sociologique*, 1898, no.1 [see also R.H. Barnes and R. Barnes, translators and editors, 1975, *On the prehistory of marriage: totemism, group marriage, mother right by Josef Kohler*, Chicago]; L. A. White, 1939, A Problem in kinship terminology, *American Anthropologist* 41:4; R. Lane and B. Lane, 1959, On the development of Dakota-Iroquois and Crow-Omaha kinship terminologies, *Southwestern Journal of Anthropology* 15:3; D. B. Eyde and P.M. Postal, 1961, Avunculocality and incest: the development of unilateral cross-cousin marriage and Crow-Omaha kinship systems, *American Anthropologist* 63:4; C.F. Moore, 1963, Oblique and asymmetrical cross-cousin marriage and Crow-Omaha terminology, *American Anthropologist* 65:2; C. Lévi-Strauss, 1949, *Les structures élémentaires de la parenté*, Paris; R. McKinley, op. cit. and, 1971, Why do Crow and Omaha kinship terminologies exist? A sociology of knowledge interpretation, *Man* 6:3; A.M. Золотарев. Из истории ранних форм группового брака. — “Ученые записки исторического факультета Московск. Обл. пед. ин-та”, т. 2, 1940 [A.M. Zolotarev, 1940, On the history of early forms of group marriage, *Scientific Notes of the Faculty of History 2 Moscow*]; Д.А. Ольдерогге Кольцевая связь родов или трехродовой союз, Краткие сообщения Ин-та этнографии АН СССР, вып. 1, 1946 [D.A. Olderogge, 1946, The circular connection of clans or a three-clan union, *Brief Communications of the Institute of Ethnography of the USSR Academy of Sciences* 1]; его же: Основные черты развития систем родства. — “Советская этнография”, 1960, № 6 [D.A. Olderogge, 1960, The main features of the development of kinship systems, *Soviet Ethnography* 6]; его же. Система родства баконго в XVII в. — “Труды Института этнографии АН СССР”, т. 54, 1960 [D.A. Olderogge, 1960, The Bakongo kinship system in the 17th century, *Proceedings of the Institute of Ethnography of the Academy of Sciences of the USSR* 54]; H.B. Бикбулатов.

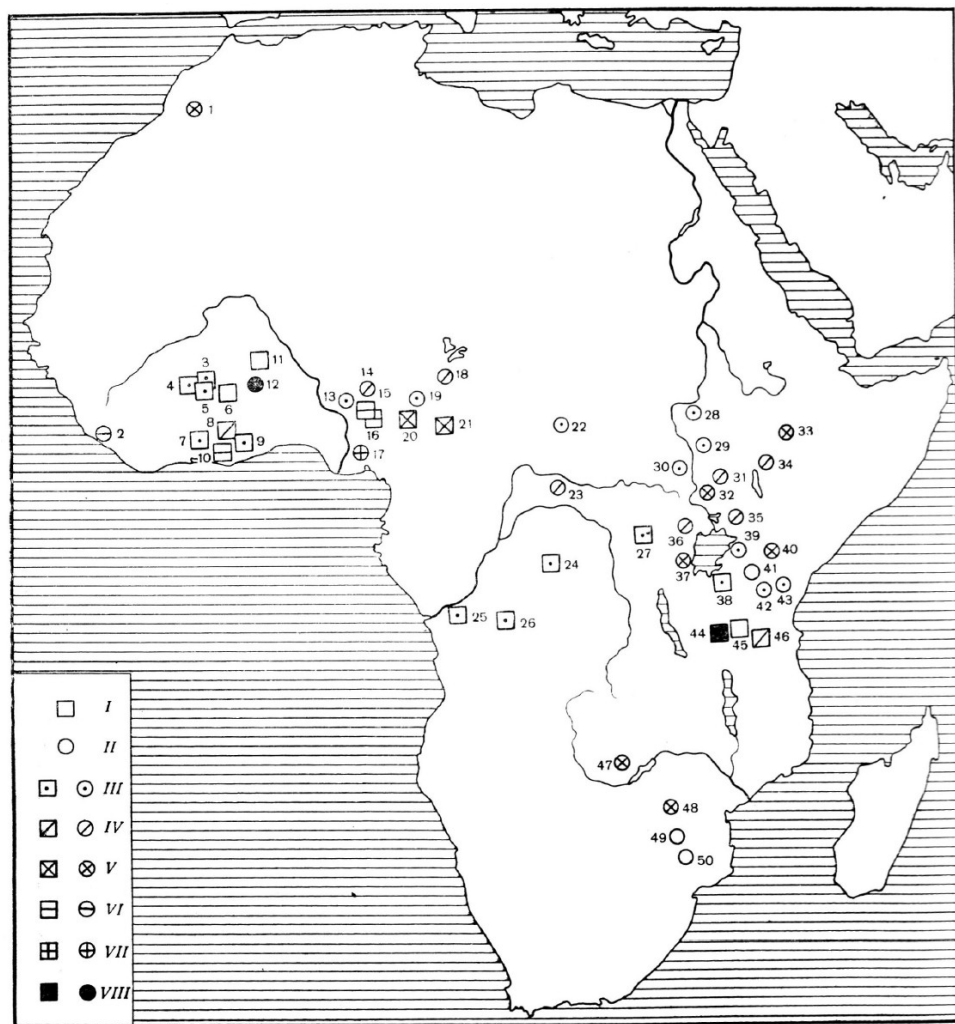

Fig. 4. Variants of the KTS of Crow and Omaha types among the peoples of Africa.

Types:

I Crow

II Omaha

Variants:

III Bifurcate

IV Bifurcate — Bifurcate-Lineal

Система родства башкир. М., 1964 [N.V. Bikbulatov, 1964, *The Bashkir kinship system*, Moscow]; Н.А. Бутинов. Папуасы Новой Гвинеи. М., 1973 [N. A. Butinov, 1973, *Papuans of New Guinea*, Moscow]; В.М. Мисюгин. Об отношении австралийских брачных классов к турано-ганованской системе родства. — “Основные проблемы африканистики”. М., 1973 [V.M. Misyugin, 1973, On the relationship of Australian marriage classes to the Turano-Ganowanian kinship system, *Main Problems in African Studies*, Moscow]; Н.М. Гиренко. Традиционная социальная организация ньямвези (основные тенденции доколониального развития). Автореферат кандидатской диссертации. Л., 1975 [N.M. Girenko, 1975, Traditional social organization of the Nyamwezi (main trends of pre-colonial development, Ph.D. Thesis Abstract, Leningrad].

- V Bifurcate-Lineal
- VI Bifurcate — Generational
- VII Generational
- VIII Bifurcate-lineal — Generational*

(the same symbols are also used on the maps below).

[*hyphens and em-dashes adjusted to concord with the listing on p. 52 of the original text.]

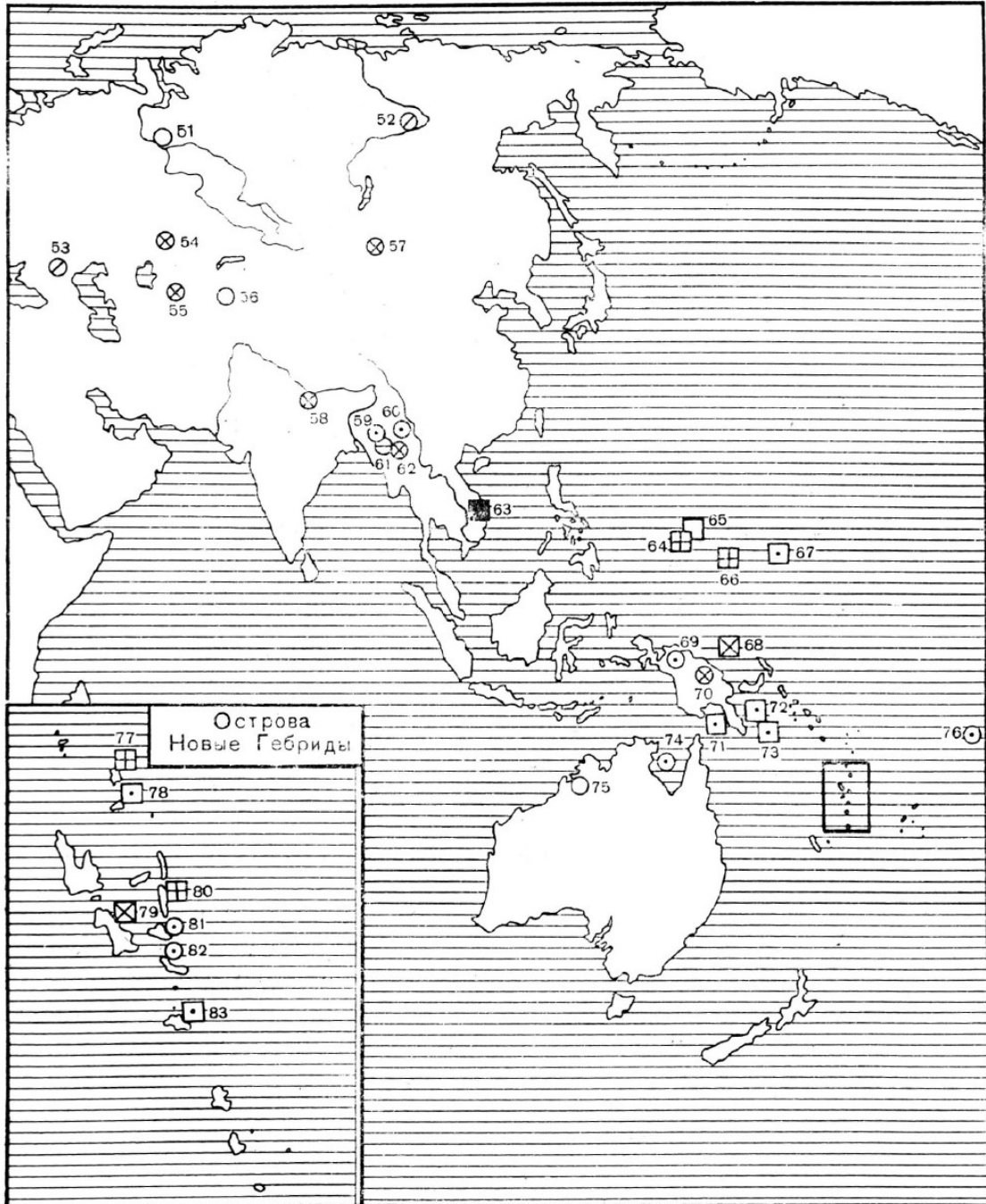

Fig. 5. Variants of the KTS of Crow and Omaha types among the peoples of Asia, Australia and Oceania (on the inlay map: The New Hebrides archipelago).

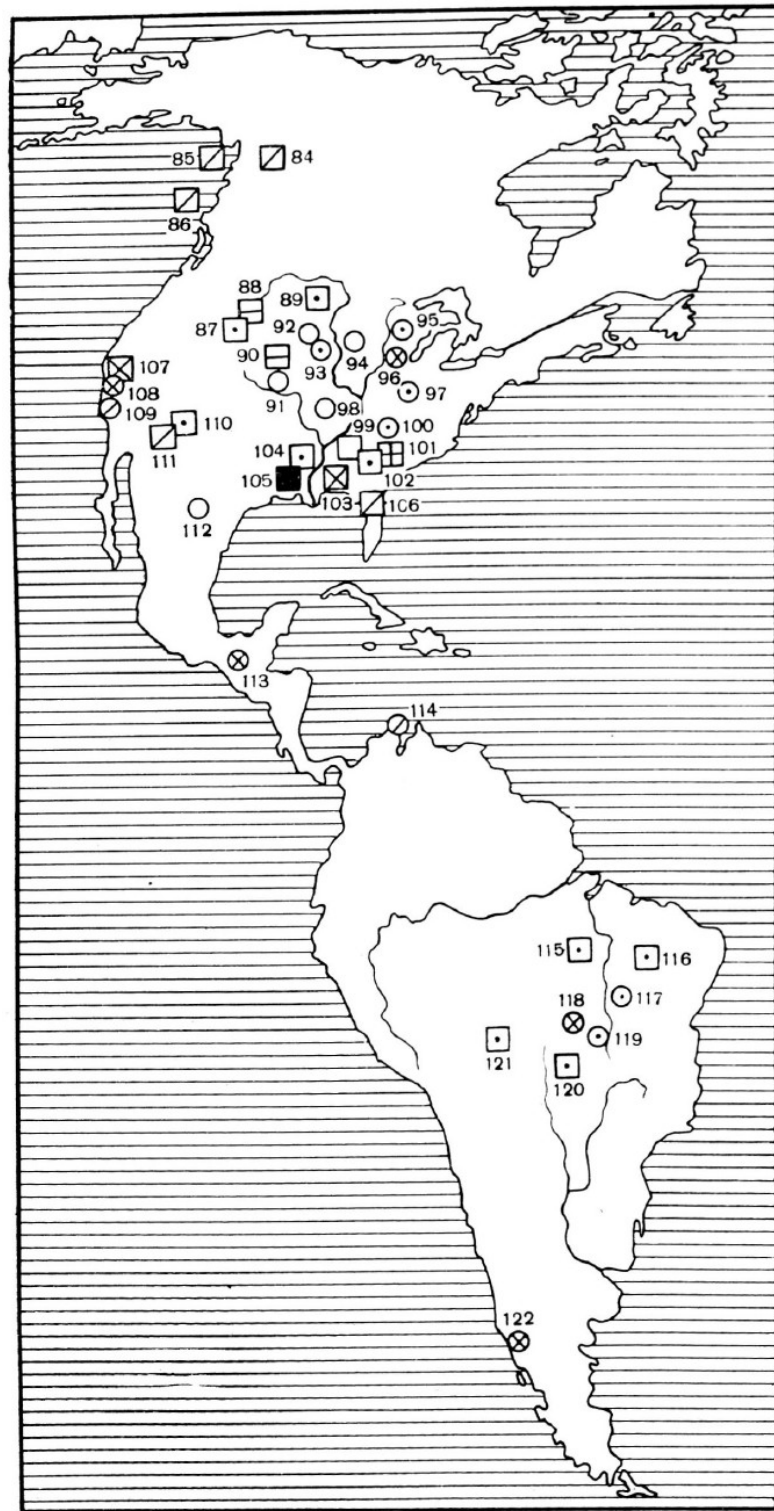

Fig. 6. Variants of the KTS of Crow and Omaha types among the peoples of America.

The second category of scholars has generally researched the inner mechanisms and structural specifics of Crow and Omaha KTS by applying formal methods of analysis from

structural linguistics.³⁴ Review of all these concepts and hypotheses of Crow and Omaha KTS origin is beyond the scope of the present article.³⁵ Here I am interested only in those works dealing with the typology of these KTS. F. Eggan³⁶ was the first to pay attention to differences between some Crow systems: he distinguished six subtypes of these systems that differ in their terms for patrilineal cross-cousins. For example, in the KTS of the Crow Indians:

$$\begin{aligned} ДМДжРРМ &= РМ & [FZS = F] \\ ДЖДжРРМ &= ДЖРРМ & [FZD = FZ] \\ ДДМДжРРМ &= ДР & [FZSC = Sb; \text{ i.e., } FZSS = B, FZSD = Z] \\ ДДЖДжРРМ &= РМ/ДЖРРМ & [FZDC = F/FZ] \end{aligned}$$

In contrast, in the Creek KTS:

$$\begin{aligned} ДМДжРРМ &= РМ & [FZS = F] \\ ДЖДжРРМ &= РЖРМ & [FZD = FM] \\ ДДДжРРМ &= РМ/ДЖРРМ & [FZCC = F/FZ]* \end{aligned}$$

* [This is an encapsulation: for Creek, Eggan also shows FM = FZ = FZCD (PW)]

Similar micro typologies were elaborated by F. Lounsbury with the aid of three transformation rules (skewing, merging and half-sibling) formulated by him, and by I.R. Buchler who applied Guttman's scalogram method with Lounsbury's transformation rules.³⁷ Lounsbury distinguished four subtypes of the Crow-Omaha KTS, and Buchler grouped 41 Crow systems in sixteen scale types³⁸ and fourteen Omaha systems in seven scale types.³⁹ However, these scale types are limited to a statement of their differences with no attempt to explain this phenomenon, whereas the differences in grouping of relatives in G+1 and G0 have critical importance for the historical typology of KTS.

In most known Crow and Omaha systems G+1 relatives are grouped according to a Bifurcate model:

³⁴ W.H. Goodenough, 1956, Componential analysis and the study of meaning, *Language* 52:1; F.G. Lounsbury, 1964, A formal account of the Crow-Omaha-type kinship terminologies, in *Explorations in Cultural Anthropology*, New York; E.A. Hammel, 1965, An algorithm for Crow-Omaha solutions, *American Anthropologist* 67:5:2; I.R. Buchler, 1966, Measuring the development of kinship terminologies: Scalogram and transformational accounts of Crow-type systems, *American Anthropologist* 66:4; I.R. Buchler, 1969, Measuring the development of kinship terminologies: Scalogram and transformational accounts of Omaha-type systems, *Bijdragen tot de Taal, Land-, en Volkenkunde* 122:1; К.И. Вавра. Семантический анализ терминов родства угорских языков. — "Советское финноугроведение", 1966, № 3 [K.I. Vavra, 1966, Semantic analysis of kinship terms of the Ugric languages, *Soviet Finno-Ugric Studies* 3].

³⁵ W.H. Goodenough, 1956, Componential analysis and the study of meaning, *Language* 52:1; F.G. Lounsbury, 1964, A formal account of the Crow-Omaha-type kinship terminologies, in *Explorations in Cultural Anthropology*, New York; E.A. Hammel, 1965, An algorithm for Crow-Omaha solutions, *American Anthropologist* 67:5:2; I.R. Buchler, 1966, Measuring the development of kinship terminologies: Scalogram and transformational accounts of Crow-type systems, *American Anthropologist* 66:4; I.R. Buchler, 1969, Measuring the development of kinship terminologies: Scalogram and transformational accounts of Omaha-type systems, *Bijdragen tot de Taal, Land-, en Volkenkunde* 122:1; К.И. Вавра. Семантический анализ терминов родства угорских языков. — "Советское финноугроведение", 1966, № 3 [K.I. Vavra, 1966, Semantic analysis of kinship terms of the Ugric languages, *Soviet Finno-Ugric Studies* 3].

³⁶ F. Eggan, 1937, Historical changes in the Choctaw kinship system, *American Anthropologist* 29:1:37.

³⁷ Lounsbury op. cit., pp. 360-379.

³⁸ Buchler 1966 op. cit., pp. 769-772.

³⁹ Buchler 1969 op. cit., pp. 44, 45.

$$[P_M = D_{MPP_M}] \neq D_{MPP_{\text{ж}}} ([F = FB] \neq MB);$$

$$[P_{\text{ж}} = D_{\text{ж}PP_{\text{ж}}}] \neq D_{\text{ж}PP_M} ([M = MZ] \neq FZ).$$

The KTS of the following peoples belong to this variant (I):⁴⁰

Crow: Lobi (3)⁴¹, Birifor (4), Dyan (5), Abron⁴² (7), Akwamu⁴³ (9), Akyem (9), Mongo (24), Kongo (25), Pende (26), Sukuma (38), Ponape (67), Motu (71), Trobrianders (72), Yela/Rossel Islanders (73), Mota (78), Efate (83), Crow (87), Mandan (89), Hidatsa (89), Cherokee (102), Choctaw (104), Hopi (110), Acoma (110), Zuni (110), Apinaye (115), Timbira (116), Bororo (120), Siriono (121);

Omaha: Igbira (13), Kadara (19), Banda (22), Amba (27), Luo (28), Nuer (29), Bari (30), Jo-Luo (39), Chaga (42), Taita (43), Thadou (59), Sema (59), Aimol (59), Kachin (60), Hakachin (60), Muyu (69), Aboriginal Australians of Groote Eylandt Island (74), Tokelau (76), Ambrym (81), Epi (82), Omaha (93), Oto (93), Fox (93), Menomini (95), Miami (97), Shawnee (100), Xerente/Sherente (117), Northern Kayapo (119).

In some systems (variant II) the grouping of G+1 relatives is characterized by Bifurcate-lineal features:

$$P_M \neq D_{MPP_M} \neq D_{MPP_{\text{ж}}} (F \neq FB \neq MB);$$

$$P_{\text{ж}} \neq D_{\text{ж}PP_{\text{ж}}} \neq D_{\text{ж}PP_M} (M \neq MZ \neq FZ):$$

Crow: Chamba Daka⁴⁴ (20), Chamba Leko (21), Manus people (68), Senyang (79), Creek (103), Wappo (107), Southern Pomo (119).

Omaha: Gurage (33), Haya (37), Kikuyu (40), Tonga (47), Shona-Zezuru (48), Kazakhs (54), Uzbeks Kungrats (55), Khalkha Mongols (57), Sherpa (58), Rengma (62), Ao (62), the Lhota Nagas (62), Purum (62), Arapesh (70), Kwoma (70), Winnebago (96), Potawatomi (96), Wintun (108), Patwin (108), Eastern Pomo (108), Xavante/Shavante (118), Tzeltals (119), Araucanians/Mapuche (122).

In three systems of the Omaha type Bifurcate-lineal features are observed not only in G+1 but also in G0: Chleuh Semlal (1), Lango (32), Angami (62).

Variant III systems have generational singularities in G+1:

$$[P_M = D_{MPP_M} = D_{MPP_{\text{ж}}}] ([F = FB = MB]);$$

$$[P_{\text{ж}} = D_{\text{ж}PP_{\text{ж}}} = D_{\text{ж}PP_M}] ([M = MZ = FZ]):$$

Crow: Truk Islanders (66), Banks Islanders⁴⁵ (77), Pentecost Islanders⁴⁶ (80), Yuchi

⁴⁰ Typologization of Crow-Omaha systems is carried out using G.P. Murdock's database (see Murdock, 1957, *World Ethnographic Sample*, *American Anthropologist* 59; and Murdock, 1970, Kin terms patterns and their distribution, *Ethnology* 9), reflecting the situation as of the mid 20th century. Murdock's data are given without references, except where material is taken from another source. Mapping of the Crow and Omaha variants is by the present author.

⁴¹ Figures in brackets refer to numbers shown on the map figures.

⁴² Lounsbury op. cit., p 367.

⁴³ M. Mead, 1937, Twi relationship systems, *Journal of the Royal Anthropological Institute* 67.

⁴⁴ C.K. Meek, 1931, *Tribal studies in Northern Nigeria*. London, 1931, vol. I, p. 402, 403.

⁴⁵ R.B. Lane, 1961, A reconsideration of Malayo-Polynesian social organization, *American Anthropologist* 63:4:712.

⁴⁶ Buchler 1966 op. cit., p. 770.

(101)

Omaha: Igbo⁴⁷ (17).

In variant IV, Bifurcate features combine with Bifurcate-lineal:

Crow: Ashanti (8), Luguru (46), Haida (86), Timucua (106), Seminole⁴⁸ (106), Hano (111).

Omaha: Gbari (14), Matakam (18), Ngbandi (23), Acholi (31), Konso⁴⁹ (34), Nyoro (36), Yakuts (52), Kalmyks (53), Miwok (109), Goajiro (114).

The Crow-type systems of Kaska (84), Tlingit (85), and the Omaha-type system of Dorobo (35) have Bifurcate characteristics in G+1 and Bifurcate-lineal ones in G0.

In variant V, systems have both Bifurcate and Generational features:

Crow: Fanti⁵⁰ (10), Longuda⁵¹ (15), Ngoro (16), Yapese (64), Arikara (88), Pawnee (90).

Omaha: Vai⁵² (2), Lakher (61).

The Crow-type systems of Mbugwe (44), Mnong Gar (63), Natchez (105) and the Omaha-type system of Konkomba (12) are characterized by a combination of bifurcate-lineal and generational features (variant VI).

I designate each of the variants distinguished as, respectively:

I Bifurcate

II Bifurcate-lineal

III Generational

IV Bifurcate — Bifurcate-lineal

V Bifurcate — Generational

VI Bifurcate-lineal — Generational.

It is not possible to classify the remaining systems of Crow and Omaha types, because there are no necessary data in specialized literature [in 1977] to include them definitively in a certain variant. Such KTS are those of the following peoples:

⁴⁷ E.W. Ardener, 1954, The kinship terminology of a group of Southern Ibo, *Africa* 24:2:92-94.

⁴⁸ Lounsbury op. cit., p. 375.

⁴⁹ C.R. Hallpike, 1972, *The Konso of Ethiopia*, Oxford, p. 344.

⁵⁰ D.B. Kronenfeld, 1973, Fanti kinship: the structure of terminology and behavior, *American Anthropologist* 75:5: 1579.

⁵¹ Meek op. cit., pp. 344, 345.

⁵² Provisionally Omaha: the data source which Murdock cites (F. Ronnefeldt, 1935, Die Heiratssitten der Vai, *Zeitschrift für Ethnologie* 67) does not give a reason to include the Vai KTS in the Omaha type. Other authors (M. Delafousse, 1899, Les Vai, *L'Anthropologie* 10; M.C. McCulloch, 1950, *The peoples of Sierra-Leone Protectorate*, London; C.E. King and E.O. Fahnbulleh, 1957, The kinship system of the Vai people of Liberia, Africa, *Sociology and Social Research* 41:6) also describe a terminology which lacks any features of the Omaha system. Other sources are unavailable [to the present author].

Crow: LoWiili⁵³ (6), Gurma (11), Iraqw (45), Ulithians⁵⁴ (65), Chickasaw⁵⁵ (99), Laguna⁵⁶ (110).

Omaha: Masai (41), Soga (46), Ndaou⁵⁷ (49), Chopi⁵⁸ (50), Khants⁵⁹ (51), Kyrgyz (56), Vorrorra⁶⁰ (75), Vunambal⁶¹ (75), Ngarinjin⁶² (75), Kansa⁶³ (91), Ponca⁶⁴ (92), Iowa⁶⁵ (94), Osage⁶⁶ (98), Kickapoo⁶⁷ (112).

Some scholars include the KTS of the ancient Germanic peoples⁶⁸ and Romans in the Omaha-type systems.⁶⁹ However, A.C. Bush denies the presence of Omaha-type features in the Romans' KTS.⁷⁰

* * *

It is apparent that two stages should be distinguished in the evolution of kinship systems:⁷¹

- (I) the stage of primary kinship systems typical for primitive societies and represented by the KTS of bifurcate type, and
- (II) the stage of secondary kinship systems inherent in complex stratified societies which develop from the first.

Secondary kinship systems pass through two evolutionary stages, the first of which corresponds to pre-industrial forms of complex societies. The KTS of Generational and Bifurcate-lineal types are related to this stage and the KTS of the Lineal type to the second. Both stages are also comparable to the two epochs into which M.V. Kryukov divided the history of the development of kinship systems. The first of these is characterized by completely classificatory

⁵³ Provisionally Omaha: the data source which Murdock cites (F. Ronnefeldt, 1935, *Die Heiratssitten der Vai, Zeitschrift für Ethnologie* 67) does not give a reason to include the Vai KTS in the Omaha type. Other authors (M. Delafousse, 1899, *Les Vai, L'Anthropologie* 10; M.C. McCulloch, 1950, *The peoples of Sierra-Leone Protectorate*, London; C.E. King and E.O. Fahnbulleh, 1957, *The kinship system of the Vai people of Liberia, Africa, Sociology and Social Research* 41:6) also describe a terminology which lacks any features of the Omaha system. Other sources are unavailable [to the present author].

⁵⁴ Buchler 1966 op. cit., p. 770.

⁵⁵ Spier op. cit., p. 74.

⁵⁶ Spier op. cit., p. 74.

⁵⁷ Lounsbury op. cit., p. 374.

⁵⁸ Lounsbury op. cit., p. 374.

⁵⁹ Вавра [Vavra] op. cit.

⁶⁰ P. Lucich, 1968, *The development of Omaha kinship terminologies in three Australian Aboriginal tribes*, Canberra.

⁶¹ Lucich op. cit.

⁶² Lucich op. cit.

⁶³ Spier op. cit., p. 73.

⁶⁴ Spier op. cit., p. 73.

⁶⁵ Spier op. cit., p. 73.

⁶⁶ Spier op. cit., p. 73.

⁶⁷ Spier op. cit., p. 73.

⁶⁸ Lounsbury op. cit., p. 375.

⁶⁹ Olderogge 1960, op. cit., p. 16; F.G. Lounsbury, 1967, *The early Latin kinship system and its relation to Roman social organization, Proceedings of the Seventh International Congress of Anthropological and Ethnological Sciences* 4:261-270, Moscow.

⁷⁰ A.C. Bush, 1971, *Latin kinship extensions: an interpretation of the data, Ethnology* 10:4:429.

⁷¹ A.C. Bush, 1971, *Latin kinship extensions: an interpretation of the data, Ethnology* 10:4:429.

systems of Bifurcate types, the second groups partly classificatory systems into three remaining types of KTS.⁷²

Thus, taking into account the historical sequence of Bifurcate, Bifurcate-lineal, Generational and Lineal types of KTS, and keeping in mind that combinations of structural features of various types in adjacent generations of the same KTS allow them to be considered as intermediate, i.e., transitional stages of development from one type to another,⁷³ the following stage sequence for the evolutionary variants of Crow and Omaha can be suggested:

Bifurcate → Generational;

Bifurcate → Bifurcate — Bifurcate-lineal → Bifurcate-lineal;

Bifurcate-lineal → Generational.

Therefore, all the KTS of Crow and Omaha types are various states of these systems, which the suggested typology classifies as a series of evolutionary stages, because the main characteristics of the KTS of Crow and Omaha types do not disappear with the transformation of Bifurcate structure into Generational and Bifurcate-lineal models. The features of these systems disappear in the next stage of evolution, with the transformation of Generational and Bifurcate-lineal types into the Lineal one. In any event, G.P. Murdock did not record any KTS which combined the characteristics of Lineal type with features of Crow and Omaha.

Without touching on the problem of Crow and Omaha KTS type origins, one can formulate a hypothesis about conservation of features of these types at the first stage of the second phase of the evolution of kinship systems. Obviously, two alternative explanations of this phenomenon are possible. The first is that these types are survivals of the preceding stage of development of these systems conserved due to inertia and stage-heterogeneity of kinship systems—in accordance with the postulate of V.I. Lenin that in examining every social phenomenon “one finds in it the remains of the past, the bases of the present and the beginnings of the future.”⁷⁴ A second explanation is that the evolution of functions has already taken place and the terminologies of Crow and Omaha type now reflect other social phenomena different from those which existed in the moment of their genesis. Although the terminology is generally the same, its content has changed, i.e., it is a combination of old elements with newly acquired qualities.

The first interpretation seems more plausible, but in some cases the second possibility should not be dismissed. For example, it is quite possible that relations between the mother’s brother and his sister’s children could take the form of inheritance relationships in a large family community, as a consequence of a semantic reinterpretation of kin-terms. In this case one could only agree with M. Mead and Ch. Meek, who explained the Crow elements in the KTS of Akwamu⁷⁵, Longuda and Chamba⁷⁶ as resulting from the influence of the matrilineal system of inheritance: ДМДжРРМ (FZS), the patrilineal male cross-cousin, is heir to РМ (F), Ego’s father, and after Ego’s father’s death occupies the latter’s social position: that is why he is called by the same term as Ego’s father, whereas ДжДжРРМ (FZD), the patrilineal female cross-cousin, is equated with Рж (M), Ego’s mother. The consequence of this is a prohibition on marriage with

⁷² Kryukov *Chinese Kinship System*, p. 270.

⁷³ G. Dole, 1969, Generation kinship nomenclature as an adaptation to endogamy, *Southwestern Journal of Anthropology* 25:2:105-123; Kryukov *Evolution of Kinship Systems*, p. 1.

⁷⁴ В.И. Ленин. Полн. собр. соч., т. 1, с. 181. [V.I. Lenin, *Collected Works*, vol. I, p. 181].

⁷⁵ Mead op. cit., p. 299.

⁷⁶ Meek op. cit., p. 596.

patrilateral cross-cousins (ДДжРРМ [FZC]) among Chamba Leko.⁷⁷ This idea is corroborated by the conclusion of D.A. Olderogge about the Nkita system among the Nkundu tribes. He found that the Nkita system established patrilateral cross-cousins (ДДжРРМ [FZC]) in a privileged position.⁷⁸

As an example of the first of the two suggested explanations, I give the Ashanti KTS, in which a tendency for Crow-system features to disappear is observed. The matrilineal cross-cousins (ДДМРРж [MBC]) are not included in the same group as Ego's children but are considered relatives of Ego's generation. The patrilateral male cross-cousin (ДмДжРРМ [FZS]) is called by the term *agya* (РМ [F]) only in cases where one wishes to show him respect.⁷⁹

As is well known, typology is not only a way of presenting material in systematized fashion but is also an instrument of scientific knowledge that helps to understand the essence of things. The process of creating a typology influences how the contents of phenomena are revealed and provides deeper insight into them, which allows us to outline further directions for research. The suggested typology of the variants of the KTS of Crow and Omaha types is directly related to the problem of the formation of these systems, because it is impossible to study their social causation without taking into account the character of differences among the variants.

⁷⁷ Meek op. cit., p. 381.

⁷⁸ Д.А. Ольдерогге. Система никта, с. 190-192 [D.A. Olderogge, The Nkita System, pp. 190-192].

⁷⁹ M. Fortes, 1950, Kinship and marriage among the Ashanti, *African Systems of Kinship and Marriage*, London, p. 271.