

UC San Diego

UC San Diego Electronic Theses and Dissertations

Title

Molecular mapping of the protein kinase A pathway: mutations, models, and mechanisms

Permalink

<https://escholarship.org/uc/item/98h3k21z>

Author

Ramms, Dana Jean

Publication Date

2021

Supplemental Material

<https://escholarship.org/uc/item/98h3k21z#supplemental>

Peer reviewed|Thesis/dissertation

UNIVERSITY OF CALIFORNIA SAN DIEGO

Molecular mapping of the protein kinase A pathway: mutations, models, and mechanisms

A dissertation submitted in partial satisfaction of the
requirements for the degree Doctor of Philosophy

in

Biomedical Sciences

by

Dana Jean Ramms

Committee in charge:

Professor J. Silvio Gutkind, Chair
Professor Napoleone Ferrara
Professor Andrew Lowy
Professor Roger Sunahara
Professor Jin Zhang

2021

The dissertation of Dana Jean Ramms is approved, and it is acceptable in quality and form for publication on microfilm and electronically.

University of California San Diego

2021

TABLE OF CONTENTS

Dissertation Approval Page.....	iii
Table of Contents.....	iv
List of Abbreviations.....	v
List of Supplemental Files.....	vii
List of Figures.....	viii
Acknowledgements.....	ix
Vita.....	xiii
Abstract of the Dissertation.....	xv
Introduction.....	1
Chapter 1 G α s-PKA pathway signalopathies: The emerging genetic landscape and therapeutic potential of human diseases driven by aberrant G α s-PKA signaling.....	3
Chapter 2 Genetic models of G α s-PKA-driven cancers.....	92
Chapter 3 Protein-protein interaction map reveals a PKA regulated RNA binding protein network.....	119
Conclusion.....	153
References.....	155

LIST OF ABBREVIATIONS

Acrodysostosis (ACRDYS), actinomycin D (ActD), adenomatous polyposis coli (APC), adenylyl cyclase (AC), adrenocorticotrophic hormone (ACTH), A-kinase anchoring protein (AKAP), Albright's hereditary osteodystrophy (AHO), autosomal dominant polycystic kidney disease (ADPKD), area under the curve (AUC), basal cell carcinoma (BCC), bromodomain and extra-terminal domain (BET), Body Mass Index Quantitative Trait Locus 19 (BMIQ19), BRAF inhibitors (BRAFi), cAMP binding domains (CBDs), cAMP response elements (CREs), cAMP-regulated transcriptional co-activators (CRTCs), cardiac myxomas (CMs), casein kinase 1 α (CK1 α), catalytic (C), Cell Recovery Solution (CRS), chimeric antigen receptor T cells (CAR-Ts), clustered regularly interspaced short palindromic repeats (CRISPR) activation (CRISPRa), colorectal cancer (CRC), CREB binding protein (CBP), cyclic nucleotide binding (CNB), cyclic nucleotide-gated (CNG), cyclooxygenase (COX), cystic fibrosis transmembrane conductance regulator (CFTR), dimerization/docking (D/D), 7,12-Dimethylbenz[a]anthracene (DMBA), endoplasmic reticulum (ER), enhanced crosslinking and immunoprecipitation (eCLIP), epithelial to mesenchymal transition, estrogen receptor alpha (ER α), E-type prostanoid receptors 2 (EP2), E-type prostanoid receptor 4 (EP4), exchange protein directly Activated by cAMP (EPAC), fibrolamellar hepatocellular carcinoma (FL-HCC), fibrous dysplasia (FD),), forskolin (Fsk), functional interaction (FI), G protein coupled receptors (GPCR), gastrointestinal (GI), gene ontology (GO), glucagon-like peptide-1 receptor (GLP1R), glycogen synthase kinase 3 (GSK3), growth hormone (GH), Hedgehog (HH), hormone receptor positive (HR+), human epidermal growth factor receptor 2 positive (HER2+), hyperpolarization-activated, cyclic nucleotide-modulated (HCN), 3-Isobutyl-1-methylxanthine (IBMX), inactivating PTH/PTHrP signaling Disorder (iPPSD), Indian Hedgehog (IHH), inhibitory sequence (IS), insulin-like growth factor-1 (IGF-1), intraductal oncocytic papillary neoplasms (IOPNs), intraductal papillary mucinous neoplasms (IPMNs), Lethal congenital contracture syndrome 8 (LCCS8), Local Kinase Inhibition (LoKI), low-grade appendiceal mucinous neoplasm (LAMN), McCune-Albright Syndrome (MAS),

melanocortin receptor (MC₂R), mesenchymal stem cells (MSCs), mitogen-activated protein kinase (MAPK), mutant (MUT), *N*⁶-methyladenosine (m⁶A), nonsense mediated decay (NMD), non-steroidal anti-inflammatory drugs (NSAIDs), pancreatic adenocarcinoma (PDAC), pancreatic intraepithelial neoplasias (PanINs), parathyroid hormone (PTH), parathyroid hormone receptor (PTHr), Patched homolog 1 (PTCH1), patient-derived xenograft (PDX), phosphodiesterase (PDE), phosphoinositide 3-kinase (PI3K), poly(ADP-ribose) polymerase (PARP), popeye domain containing (POPDC), primary macronodular adrenal hyperplasia (PMAH), primary pigmented nodular adrenocortical disease (PPNAD), progressive osseous heteroplasia (POH), prolactin (PRL), prostaglandin E₂ (PGE₂), protein kinase A, protein kinase inhibitor (PKI), protein phosphatase 1 (PP1), protein phosphatase 2A (PP2A), Proteolysis targeting chimeras (PROTACs), pseudohypoparathyroidism (PHP), pseudomyxoma peritonei (PMP), quantitative reverse transcription PCR (RT-qPCR), reverse tetracycline-controlled transactivator (rtTA), RNA binding protein (RBP), RNA interference (RNAi), regulator of G protein signaling (RGS), regulatory (R), single nucleotide polymorphisms (SNPs), sinoatrial (SA), small cell lung cancer (SCLC), Smoothed (SMO), somatostatin family of GPCRs (SSTRs), Sonic Hedgehog (SHH), Sonic Hedgehog Medulloblastoma (SHH-MB), squamous cell carcinoma (SCC), tetraiodothyronine (T₄), 12-O-Tetradecanoylphorbol-13-acetate (TPA), tetracycline responsive element (TRE), steroidogenic acute regulatory protein (StAR), tetraiodothyronine (T₄), thyroid-stimulating hormone (TSH), thyroid-stimulating hormone receptor (TSHR), transcripts per million (TPM), triiodothyronine (T₃), untranslated region (UTR), wild-type (WT), X-linked acrogigantism (XLAG)

LIST OF SUPPLEMENTAL FILES

Table S1. Expression of PKA pathway components

Table S2. Pathway mutational data from genetic diseases

Table S3. Residue mutational data in cancer

Table S4. Cancer fusion protein data

Table S5. PKA mutational data in cancer

Table S6. Organoid cell population profiling primers

Table S7. Complete PKA interactome

Table S8. Shared interactions among baits

Table S9. Candidate list of m6A RNAs bound by IMPs

Table S10. RNA binding protein target RNA primers

LIST OF FIGURES

Figure 1. PKA is a central regulatory hub.....	6
Figure 2. PKA pathway components.....	10
Figure 3. CREB-mediated transcription and other cAMP effectors.....	16
Figure 4. <i>GNAS</i> mutational themes in disease.....	24
Figure 5. PKA mutational themes.....	28
Figure 6. PKA fusion proteins in cancer.....	35
Figure 7. Network map of Gas-PKA pathway mutations in genetic diseases.....	39
Figure 8. Pathophysiology of Gas-PKA pathway signalopathies.....	44
Figure 9. Gas-PKA pathway mutations in cancer.....	56
Figure 10. Aberrant Gas-PKA pathway activity leads to dysregulation of transcription.....	65
Figure 11. Co-occurrence of <i>GNAS</i> and <i>KRAS</i> mutations.....	96
Figure 12. Transgenic mouse model of <i>GNAS</i> and <i>KRAS</i> co-mutation.....	99
Figure 13. Chemical model of <i>GNAS-Ras</i> -induced carcinogenesis.....	102
Figure 14. Intestinal organoid model of <i>GNAS</i> and <i>KRAS</i> co-mutation.....	106
Figure 15. Generation of PKA baits.....	123
Figure 16. PKA Ca interaction network.....	126
Figure 17. PKA $\text{RI}\alpha$ interaction network.....	128
Figure 18. Network quantification.....	129
Figure 19. Validation of interactions with HuR and IMPs.....	131
Figure 20. PKA promotes N^6 -methyladenosine (m ⁶ A) RNA stabilization.....	135
Figure 21. BRD4 is a potential therapeutic target in Gas-PKA pathway-driven cancers.....	139
Figure S1. Correlation of PKA and IMP-3.....	152

ACKNOWLEDGEMENTS

First, I would like to sincerely thank Dr. J. Silvio Gutkind as my scientific mentor and chair of this committee for his support and guidance over the past 6 years. His has challenged and encouraged me every step of the way, enabling me to grow and mature into the best scientist I can be. The training and lessons I have learned in the Gutkind lab have truly shaped me as a scientist and I will proudly carry them with me for the rest of my career.

Second, I would like to thank the many members of the Gutkind lab, past, present, and future for creating an amazing environment to mature as a scientist. In particular, I would like to thank Dr. Walt Amornphimoltham for his mentorship and friendship early on in my graduate career. The lessons I learned from Walt have been absolutely invaluable. I would also like to thank Dr. Xuefeng Zhao for his friendship, I am proud to relinquish the title of “Senior Graduate Student.” I would like to thank Nadia Arang and Vicky Wu for their many roles during my graduate career, including labmates, collaborators, sanity checkers, encouragers, explorers, travel buddies, coffee addicts, ghosts, and most importantly friends. Thank you for bringing so much enjoyment to each day in lab. Finally, I would like to thank Dr. Zhiyong (Yoyo) Wang as an honorary ghost for both your friendship, advice, and good humor.

I would like to thank the many members of the Biomedical Sciences Graduate Program, Department of Pharmacology, and Moores Cancer Center for countless scientific discussions, collaborations, and advice throughout my graduate career. In particular, I would like to thank the many BMS students who are and continue to be great colleagues and friends.

I would like to thank the Dream Team for being an amazing group of friends both on and off the soccer field.

Finally, I would like to thank my family and friends for their constant support throughout my graduate career. Encouraging me to follow my passion and explore a new city and state even if it meant moving far away. In particular, my Mom and Dad who have always been my biggest

fans and supporters. Their encouragement from both near and far has kept me going every day. I would also like to thank my brother, Brad, for piquing my interest in the PharmTox program as an undergraduate, if you hadn't hated research so much, I may not have realized how much I enjoyed it! Also thanks for being a great ski buddy. Most of all thank you to my husband, Bastian. You have been by my side throughout my whole graduate experience, both the ups and the downs. Thank you for being a constant source of joy and humor. Thank you for your patience, when 5 more minutes in lab turns into an hour. Thank you for being my best friend, biggest rival, and favorite adventurer. I love you!

Chapter 1, in full, is a reprint of an accepted manuscript that is currently under revision with *Pharmacological Reviews*. Ramms, D.J., Raimondi, F., Arang, N., Herberg, F. Taylor, S.S., and Gutkind, J.S. (2021). Gas-PKA pathway signalopathies: The emerging genetic landscape and therapeutic potential of human diseases driven by aberrant Gas-PKA signaling. The dissertation author is the primary investigator and author of this paper.

We would like to acknowledge Dr. Alexandr Kornev at the University of California San Diego for his help preparing PKA structure graphics. We would also like to thank Dr. Daniela Bertinetti at the University of Kassel and Dr. Bjørn Steen Skålhegg at the University of Oslo for their helpful discussions related to cAMP analogs and mouse models of PKA, respectively. Finally, we would like to acknowledge the use of BioRender.com in creating many of our graphics.

Chapter 2, specifically the development of skin cancer mouse models, is currently being prepared for publication. Ramms, D.J., Callejas-Valera, J.L., Amornphimoltham, P., Molinolo, A.A., Tamayo, P., and Gutkind, J.S. (2021). G protein signaling primes Ras-driven tumorigenesis. The dissertation author was the primary investigator and author of this material. Additionally, the intestinal organoid mouse models discussed in Chapter 2 were generated in collaboration with Dr. Hervé Tiriack and Dr. Andrew Lowy at the University of California San Diego. Ramms, D.J.,

Tiriac, H., Lowy, A.M., and Gutkind, J.S. (2021) Chapter 2, Organoid model of *GNAS* and *KRAS* co-mutation.

I would like to thank additional members of the Lowy lab, including Dr. Randall French and Dr. Tatiana Hurtado De Mendoza for their many helpful discussions and technical advice regarding human and mouse organoid cultures. I would also like to thank Dr. Eduardo Villar and Dr. Prashant Bommi at MD Anderson Cancer Center for their help preparing conditioned media and optimizing organoid culture. I would like to acknowledge the Moores Cancer Center Biorepository and Tissue and Technology Shared Resource for assistance in acquiring patient tissues for organoid generation and model optimization. I would also like to thank Dr. Zhiyong Wang and Dr. Robert Saddawi-Konefka for their help in mouse model development. I would like to thank Dr. William Kim for his help exploring the *GNAS-KRAS* genetic interactions. Finally, I would like to thank Dr. Olivier Harismendy, Joseph Steward, and Daniela Nachmanson for their helping with related sequencing experiments in mouse models.

Chapter 3, in full, is currently being prepared for submission for publication. Ramms, D.J., Adame-García, S.R., Burghi, V., Swaney, D.L., Arang, N., Zhou, Y. Stevenson, E., Taylor, S.S., Yeo, G.W., Krogan, N.J., and Gutkind, J.S. (2021). Protein-protein interaction map reveals a PKA regulated RNA binding protein network. The dissertation author was the primary investigator and author of this material.

I would also like to thank Dr. Friedrich Herberg at the University of Kassel and Dr. Bjørn Steen Skålhegg at the University of Oslo for their helpful discussions related to the PKA interactome map. I would like to thank past and current members of the Yeo lab, specifically Ryan Marina, Emily Wheeler, Jackie Einstein, Kris Brannan, and Steven Blue, for their help with reagents and technical advice. Finally, I would like to thank the many members of the Cancer Cell Map Initiative (CCMI) for scientific discussions and technical advice. I would like to acknowledge Biorender.com for assistance in generating graphics for this Chapter.

I was supported in this work financially by the National Institutes of Health Cellular and Molecular Pharmacology Training Grant [T32 GM007752], the National Science Foundation Graduate Research Fellowship Program [GRFP], and Cancer Cell Map Initiative (CCMI) Cancer Systems Biology Training Program [U54 CA209891].

VITA

- 2015 Bachelor of Science, University of Wisconsin-Madison
2021 Doctor of Philosophy, University of California San Diego

PUBLICATIONS

- Ramms, D.J.**, Raimondi, F., Arang, N., Herberg, F. Taylor, S.S., Gutkind, J.S. (2021). Gas-PKA pathway signalopathies: The emerging genetic landscape and therapeutic potential of human diseases driven by aberrant Gas-PKA signaling. *Pharmacological Reviews* (*Accepted in principle, under revision*).
- Ramms, D.J.**, Adame-García, S.R., Burghi, V., Swaney, D.L., Arang, N., Zhou, Y. Stevenson, E., Taylor, S.S., Yeo, G.W., Krogan, N.J., and Gutkind, J.S. (2021). Protein-protein interaction map reveals a PKA regulated RNA binding protein network. *In preparation*.
- Ramms, D.J.**, Callejas-Valera, J.L., Amornphimoltham, P., Molinolo, A.A., Tamayo, P., and Gutkind, J.S. (2021). G protein signaling primes Ras-driven tumorigenesis. *In preparation*.
- Swaney, D.L., **Ramms, D.J.**, Wang, Z., Park, J., Goto, Y., Soucheray, M., Bhola, N., Kim, K., Zheng, F., Foussard, H., Zeng, Y., O'Keefe, R., Jin, N., VanLandingham, N.K., Von Dollen, J., Herrington, K.A., Bouhaddou, M., McGregor, M., Jimenez-Morales, D., Obernier, K., Kreisberg, J.F., Kim, M., Johnson, D.E., Jura, N., Grandis, J.R., Gutkind, J.S., Ideker, T., and Krogan, N. (2021). A protein network map of head and neck cancer reveals PIK3CA mutant drug sensitivity. *Science* (*Resubmitted*).
- Zheng, F., Kelly, M.R., **Ramms, D.J.**, Heintschel, M., Tao, K., Tutuncuoglu, B., Lee, J., Ono, K., Foussard, H., Chen, M., Herrington, K.A., Silva, E., Liu, S., Chen, J., Churas, C., Wilson, N., Kratz, A., Park, J., Kuenzi, B., Yu, M.K., Licon, K., Pratt, D., Kreisberg, J.F., Kim, M., Swaney, D.L., Nan, X., Fraley, S.I., Gutkind, J.S., Krogan, N.J., and Ideker, T. (2021). Interpretation of cancer mutations using a multi-scale map of protein systems. *Science* (*Resubmitted*).
- Ruiz-Saenz, A., Atreya, C.E., Wang, C., Pan, B., Dreyer, C.A., Brunen, D., Prahallad, A., Spassov, D., **Ramms, D.J.**, Fewings, E., Hwang, C.Y., Cowdrey, C., Muñoz, D.P., Hann, B., VandenBerg, S.R., Shokat, K., Moasser, M.M., Bernards, R., Gutkind, J.S., van 't Veer, L.J., and Coppé, J. (2021). A reversible SRC-relayed COX2-inflammatory program drives therapeutic resistance in BRAFV600E colorectal tumors. *Nature Cancer* (*In revision*).
- Burghi, V., Paradis, J.S., **Ramms, D.J.**, Acosta, M., von Zastrow, M. and Gutkind, J.S. G protein and GRK essentiality reveal receptor signaling dynamics. *In preparation*.
- Gilardi, M., Wu, V.H., Saddawi-Konefka, R., Lopez-Ramirez, M., Wang, Z., Soto, F., **Steffen, D.J.**, Proietto, M., Mikulski, Z., Miki, H., Sharabi, A., Kupor, D., Rueda, R., Wang, J., and Gutkind, J.S. (2021). Microneedle-mediated intratumoral delivery of anti-CTLA-4 promotes cDC1-dependent eradication of oral squamous cell carcinoma with limited irAEs. *Molecular Cancer Therapeutics* (*In revision*).
- Wang, Z., Feng, X., Molinolo, A.A., Martin, D., Vitale-Cross, L., Nohata, N., Ando, M., Wahba, A., Amornphimoltham, P., Wu, X., Gilardi, M., Allevalo, M., Wu, V., **Steffen, D.J.**, Tofilon, P., Sonenberg, N., Califano, J., Chen, Q., Lippman, S.M., and Gutkind, J.S. (2019). 4E-BP1 Is a Tumor Suppressor Protein Reactivated by mTOR Inhibition in Head and Neck Cancer. *Cancer Research* 79(7):1438-1450. DOI: 10.1158/0008-5472.CAN-18-1220. PMID: 30894372.

Ideno, N., Yamaguchi, H., Ghosh, B., Gupta, S., Okumura, T., **Steffen, D.J.**, Fisher, C.G., Wood, L.D., Singhi, A.D., Nakamura, M., Gutkind, J.S., and Maitra, A. (2018). GNAS^{R201C} Induces Pancreatic Cystic Neoplasms in Mice That Express Activated KRAS by Inhibiting YAP1 Signaling. *Gastroenterology* 155(5):1593-1607. DOI: 10.1053/j.gastro.2018.08.006. PMID: 30142336.

Zhao, X., Deng, P., Iglesias-Bartolome, R., Amornphimoltham, P., **Steffen, D.J.**, Jin Y., Molinolo, A.A., Fernandez de Castro, L., Ovejero, D., Yuan, Q., Chen, Q., Han, X., Bai, D., Taylor, S.S., Yang, Y., Collins, M.T., and Gutkind, J.S. (2018). Expression of an active Gas mutant in skeletal stem cells is sufficient and necessary for fibrous dysplasia initiation and maintenance. *PNAS* 115(3):E428-E437. DOI: 10.1073/pnas.1713710115. PMID: 29282319.

O'Hayre, M., Eichel, K., Avino, S., Zhao, X., **Steffen, D.J.**, Feng, X., Kawakami, K., Aoki, J., Messer, K., Sunahara, R., Inoue, A., von Zastrow, M., and Gutkind, J.S. (2017). Genetic evidence that β -arrestins are dispensable for the initiation of β_2 -adrenergic receptor signaling to ERK. *Science Signaling* 10(484), eaal3395. DOI: 10.1126/scisignal.aal3395. PMID: 28634209.

Petras, D., Nothias, L., Quinn, R. A., Alexandrov, T., Bandeira, N., Bouslimani, A., Castro-Falcón, G., Chen, L., Dang, T., Floros, D. J., Hook, V. Y. H., Garg, N., Hoffner, N., Jiang, Y., Kapono, C. A., Koester, I., Knight, R., Leber, C. A., Ling, T., Luzzatto-Knaan, T., McCall, L., McGrath, A. P., Meehan, M. J., Merritt, J. K., Mills, R. H., Morton, J., Podvin, S., Protsyuk, I., Purdy, T., Satterfield, K., Searles, S., Shah, S., Shires, S., **Steffen, D.**, White, M., Todoric, J., Tuttle, R., Wojnicz, A., Sapp, V., Vargas, F., Yang, J., Zhang, C., and Dorrestein, P. C. (2016). Mass Spectrometry-Based Visualization of Molecules Associated with Human Habitats. *Analytical Chemistry* 88(22), pp 10775–10784. DOI:10.1021/acs.analchem.6b03456. PMID: 27732780.

Wang, Y., Tu, S., **Steffen, D.**, and Xiong, M. P. (2014). Iron Complexation to Histone Deacetylase Inhibitors SAHA and LAQ824 in PEGylated Liposomes Can Considerably Improve Pharmacokinetics in Rats. *Journal of Pharmacy & Pharmaceutical Sciences* 17(4):583-602. PMID: 25579435.

Wang, Y., Zeng, S., Lin, T., Krugner-Higby, L., Lyman, D., **Steffen, D.**, and Xiong, M. P. (2014). Evaluating the Anticancer Properties of Liposomal Copper in a Nude Xenograft Mouse Model of Human Prostate Cancer: Formulation, In Vitro, In Vivo, Histology and Tissue Distribution Studies. *Pharmaceutical Research* 31:3106–3119. DOI 10.1007/s11095-014-1403-6. PMID: 24848339.

ABSTRACT OF THE DISSERTATION

Molecular mapping of the protein kinase A pathway:
mutations, models, and mechanisms

by

Dana Jean Ramms

Doctor of Philosophy in Biomedical Sciences

University of California San Diego, 2021

Professor J. Silvio Gutkind, Chair

As a central regulatory hub, protein kinase A (PKA) coordinates numerous biological processes, including discrete effects on metabolic enzymes all the way to global effects on organism growth and development. Given the diversity of roles PKA can play in normal physiology it is not surprising that dysregulation of PKA leads to diverse pathophysiology and disease. While PKA is one of the most studied kinases, its role in diseases has remained largely unknown. With this dissertation, I aim to map the contributions of the Gas-PKA pathway in disease from multiple

perspectives. First, I aim to unify the view of PKA-driven pathophysiology by utilizing mutational data from hereditary diseases and cancer databases to define a family of diseases known as the G α s-PKA pathway signalopathies. Further I utilize evidence from the scientific literature to bring functional understanding to these diverse disease states. Second, I leverage our genetic understanding of PKA pathway mutations to develop several transgenic mouse models of cancer, providing evidence of the role of *GNAS* in cancer initiation and tools for application in multiple tissue contexts. Finally, I take advantage of affinity purification mass spectrometry (AP-MS) approaches to identify novel PKA interactors. I uncover several functional themes and ultimately focus on specific RNA binding proteins interactions that mediate new mechanisms of posttranscriptional regulation. In total, this dissertation makes important progress towards the understanding of PKA-driven disease, providing a framework for the advancement of the field and ultimately unique opportunities for identifying therapeutic interventions.

INTRODUCTION

Protein kinase A (PKA) has paved the way in many respects of science. Although it was not completely understood at the time, signaling through the PKA pathway was the subject of two Nobel prizes, identifying the role of cAMP as a second messenger (Sutherland and Rall, 1958) and describing the function of reversible protein phosphorylation, ultimately implicating PKA in a kinase cascade (Walsh et al., 1968). From there, PKA went on to become one of the first kinases to have its crystal structure solved (Knighton et al., 1991a; Knighton et al., 1991b). These early discoveries led to an explosion of research in diverse fields, including metabolic regulation, hormonal growth and development, and even neurological function, highlighting the many biological roles of PKA. To facilitate such diverse actions, the activity of PKA is elegantly regulated. This includes integration of multiple signaling inputs, specificity of tissue expression, isoform diversity, and spatial-temporal control (Skalhegg and Tasken, 2000).

With a recent shift in scientific focus towards translational, disease-based research, drug targetability has become increasingly important. Major drug targets include, G protein coupled receptors (GPCRs), ion channels, and kinases (Santos et al., 2017). Despite its early fame pioneering the principles of kinase function, no clinical grade inhibitors exist for PKA. This fact points back to the diversity of PKA functions making it difficult to understand its role in specific disease pathologies (Chapter 1, Ramms, et al.). Despite these obvious challenges, the emergence of genomic sequencing and unbiased functional screens has provided a tremendous opportunity to establish PKA's role in disease by tying together existing knowledge with cutting edge systems biology approaches. As the title of this dissertation suggests, my goal has been to map the PKA pathway at several different levels, each providing insight, tools, and resources to better understand the unique contributions of PKA to diverse disease states. In Chapter 1, I integrate genetic mutation information from hereditary diseases and cancer mutational databases to unify Gas-PKA pathway-mediated pathophysiology under the umbrella of "Gas-PKA pathway

signalopathies". By taking a pathway-centric view, I provide genotype to phenotype understanding and outline opportunities for therapeutic intervention. Chapter 2 builds on these concepts, aiming to develop mouse models of pathway-driven cancer using a common genetic theme, co-occurrence of *GNAS* and *KRAS* mutations. Finally, in Chapter 3, I establish a functional PKA interaction map, leveraging the dynamics of PKA holoenzyme stability to identify novel interacting partners. Ultimately, I implicated PKA in the regulation of RNA stability through a mechanism that highlights a new therapeutic vulnerability of pathway-sensitive cancers. Together this work represents the first attempt to synthesize the field of PKA-driven disease and outlines a blueprint for future research. It is my hope that by bringing together diverse fields of study from basic biochemistry to clinical practice, the cross-talk of perspectives and expertise can catalyze new progress towards understanding PKA-driven disease and eventually provide opportunities for therapeutic intervention.

CHAPTER 1

G α s-PKA pathway signalopathies: The emerging genetic landscape and therapeutic potential of human diseases driven by aberrant G α s-PKA signaling

Abstract

Many of the fundamental concepts of signal transduction and kinase activity are attributed to the discovery and crystallization of cAMP-dependent protein kinase, or protein kinase A. PKA is one of the best studied kinases in human biology, with emphasis in biochemistry and biophysics, all the way to metabolism, hormone action, and gene expression regulation. It is surprising, however, that our understanding of PKA's role in disease is largely underappreciated. Although genetic mutations in the PKA holoenzyme are known to cause diseases such as Carney Complex, Cushing's Syndrome, and acrodysostosis, the story largely stops there. With the recent explosion of genomic medicine, we can finally appreciate the broader role of the Gas-PKA pathway in disease, with contributions from aberrant functioning G proteins and G protein coupled receptors (GPCRs) as well as multiple alterations in other pathway components and negative regulators. Together, these represent a broad family of diseases we term the Gas-PKA pathway signalopathies. The Gas-PKA pathway signalopathies encompass diseases caused by germline, post-zygotic, and somatic mutations in the Gas-PKA pathway, with largely endocrine and neoplastic phenotypes. Here we present a signaling-centric review of Gas-PKA-driven pathophysiology and integrate computational and structural analysis to identify mutational themes commonly exploited by the Gas-PKA pathway signalopathies. Major mutational themes include hotspot activating mutations in *GNAS* and mutations in *PRKACA* and *PRKAR1A* that destabilize PKA holoenzyme interactions. With this review, we hope to incite further study and ultimately the development of new therapeutic strategies in the treatment of a wide range of human diseases.

Introduction

cAMP-dependent protein kinase, or protein kinase A, was one of the first kinases to be described as part of a signal transduction cascade and has served as the prototypical example ever since. As a holoenzyme, consisting of a regulatory (R) subunit dimer and two catalytic (C) subunits, PKA orchestrates complex protein phosphorylation networks by integrating upstream

second messenger signals with spatial access to substrates; each layer is elegantly regulated to maintain homeostatic signaling across a diverse array of cell types. These signals manifest as a wide spectrum of physiologic functions, ranging from steroidogenesis in the adrenal cortex to stem cell maintenance in the hair follicle (Figure 1A). Given this diversity and complex regulation, it is not surprising that mutations and dysregulation of PKA signaling can play a causative role in many human diseases. However, despite the vast amount of information surrounding PKA and its myriad of physiological functions, the broad role of aberrant PKA signaling in disease is largely underappreciated. The study of Signalopathies, or genetic disorders of signaling pathways, has emerged in recent years, including focuses on the Ras pathway (Rasopathies) (Tidyman and Rauen, 2009) and the TGF- β pathway (TGF- β Signalopathies) (Cannaerts et al., 2015). Here we define the newest member of the Signalopathies, the Gas-PKA pathway signalopathies. Gas-PKA pathway signalopathies are defined as a family of diseases caused by germline, postzygotic, and somatic mutations in the Gas-PKA pathway, with mutations commonly seen in *GNAS*, *PRKACA*, and *PRKAR1A*. In particular, we focus on endocrine and neoplastic diseases where genetic data is strongly supported by mechanistic understanding of pathophysiology. With this review, we aim to bring together the existing body of knowledge surrounding aberrant pathway signaling in disease, bridging biochemistry, biology, physiology, and clinical practice under the umbrella of Gas-PKA pathway signalopathies. By synthesizing the field, we hope to catalyze new efforts into the therapeutic targeting of a wide variety of human Gas-PKA-driven diseases, ranging from endocrine and metabolic diseases to cancer.

I. Gas-PKA pathway basics

PKA is one of the best characterized kinases and is a founding member of a large family of serine threonine kinases known as the ACG kinases (Hanks and Hunter, 1995). In 1991, PKA became the first kinase to have its crystal structure determined (Knighton et al., 1991a; Knighton et al., 1991b) and a similar architecture has now been characterized in over 550 structures to

Figure 1. A) Protein kinase A is a central regulatory hub that mediates many physiologic processes from hormonal growth and metabolism to transport and secretion. B) Tables display the corresponding protein and gene names for each isoform of regulatory subunit and catalytic subunit. C) Cartoon rendering of the PKA regulatory and catalytic subunit interactions. The interface of the catalytic subunit's N-lobe (white) and C-lobe (olive) form the active site of the kinase, helping to coordinate ATP and substrate. When the regulatory subunit is bound to the catalytic subunit, the inhibitory sequence (IS) occupies the active site to maintain the PKA holoenzyme in its inactive state. PKA exists as a holoenzyme composed of two regulatory and two catalytic subunits, that is coordinated through interactions with the dimerization/docking (D/D) domains, which also bind to A kinase anchoring proteins (AKAPs) (see Figure 5D). When cAMP binds to and inactivates the two cAMP binding domains (CBD-A and CBD-B in teal) of the regulatory subunit, the catalytic subunit is free to phosphorylate its substrates.

A

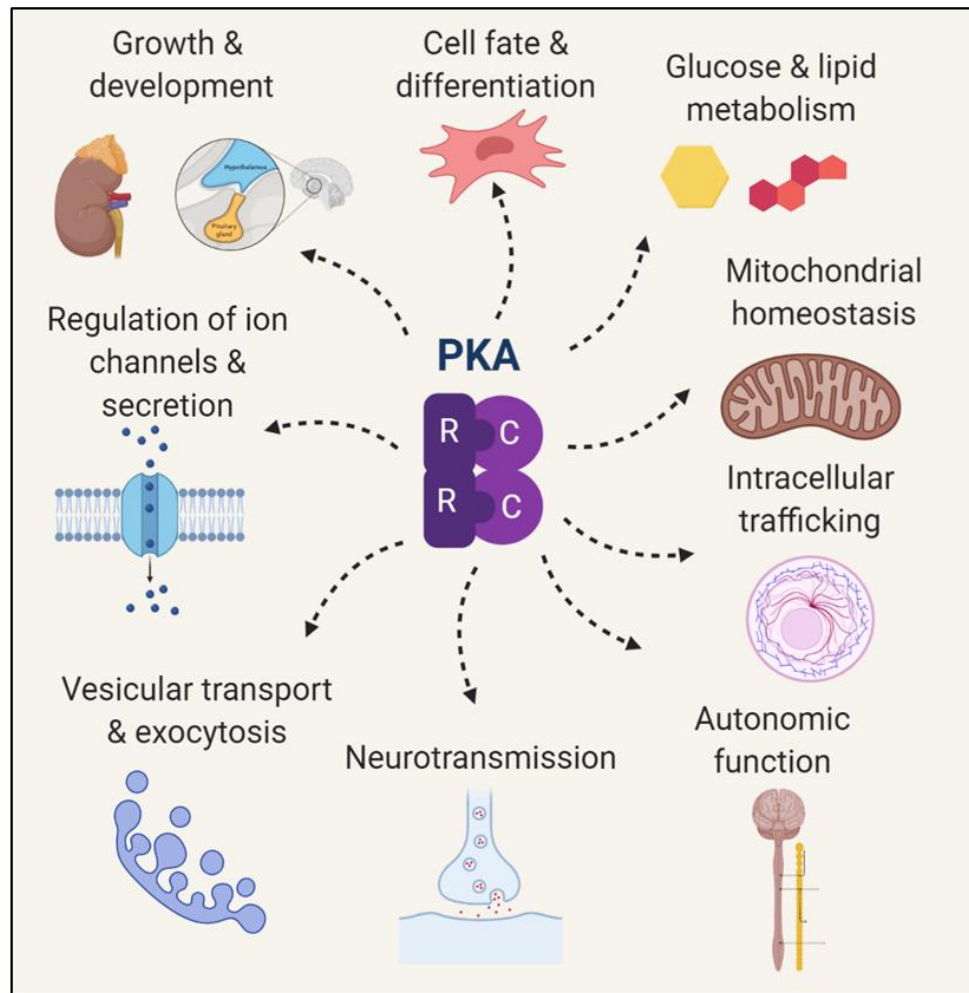

B

Regulatory Subunits (R)	Gene Name
R1 α	<i>PRKAR1A</i>
R1 β	<i>PRKAR1B</i>
R2 α	<i>PRKAR2A</i>
R2 β	<i>PRKAR2B</i>

Catalytic Subunits (C)	Gene Name
C α	<i>PRKACA</i>
C β	<i>PRKACB</i>
C γ	<i>PRKACG</i>
C χ	<i>PRKX</i>
C ψ	<i>PRKY</i>

C

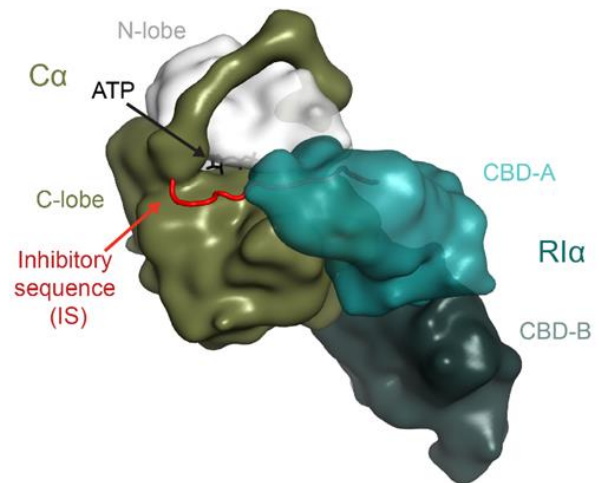

date. Traditionally, PKA exists as a tetrameric holoenzyme consisting of a homodimer of regulatory subunits (RI α , RI β , RII α , or RII β ; encoded by the *PRKAR1A*, *PRKAR1B*, *PRKAR2A*, *PRKAR2B* genes, respectively) bound to two catalytic subunits (C α , C β , C γ , or the related C χ and C ψ ; encoded by *PRKACA*, *PRKACB*, *PRKACG*, *PRKX*, and *PRKY*, respectively) (Figure 1B and C)(Taylor et al., 2021; Turnham and Scott, 2016). Under physiologic conditions, PKA becomes active when the second messenger 3', 5'-cyclic adenosine monophosphate (cAMP) binds to the cAMP binding domains (CBDs) of the regulatory subunits and unleashes activity of the catalytic subunits (Kim et al., 2006; Turnham and Scott, 2016) (Figure 1C).

1. Fine tuning cAMP levels

The level of cAMP in cells is tightly controlled by balancing production from adenylyl cyclase (AC) and degradation by phosphodiesterase (PDE) (Figure 2A), of which there are ten AC isoforms(Hanoune and Defer, 2001) and eight PDE families known to act on cAMP (an additional three PDEs are specific to cGMP)(Omori and Kotera, 2007). Upstream signals that feed into the cAMP-PKA pathway are largely provided by inputs from Gas (stimulatory)- and Gai (inhibitory)-linked heterotrimeric G protein coupled receptors (GPCRs) on the cell surface (Figure 2A). Gas is encoded by *GNAS* while Gai is encoded by *GNAI1/2/3*. GPCR activity can be modulated by a variety of extracellular ligands, such as hormones, ultimately controlling the activation of their intracellularly coupled G proteins. Heterotrimeric G proteins consist of α , β , and γ subunits, of which there are several isoforms of each, including four major G α families (Gas, Gai, G α_q , G $\alpha_{12/13}$). Upon activation, G proteins dissociate from the receptor and are capable of activating downstream effectors(Oldham and Hamm, 2008). The majority of AC isoforms reside at the membrane and are regulated by Gas and Gai (AC1-9). Additionally, some isoforms can be activated by G $\beta\gamma$ (AC 2/4/7), but conversely for AC5 and AC6, activation of G $\beta\gamma$ and phosphorylation by PKA can initiate negative regulation of cyclase activity. Of note, some AC

isoforms can be activated (AC1/3/8 through calmodulin) or inhibited (AC5/6) by physiologic levels of Ca^{2+} (Hanoune and Defer, 2001). Unlike the other isoforms, soluble AC (*ADCY10*) resides in the cytoplasm and inside the mitochondrial matrix where it is responsive to changes in both calcium and bicarbonate (Tresguerres et al., 2011) (Figure 2A). Additional details about adenylyl cyclase isoforms and their signaling activities have been previously reviewed (Halls and Cooper, 2017; Hanoune and Defer, 2001; Sanchez-Collado et al., 2021; Schmid et al., 2014).

Much like AC isoforms, the PDEs also have tissue-specific expression patterns and non-redundant function (Figure 2B, Table S1). Adding to the complexity of cAMP dynamics, many variants exist for each PDE gene due to the use of alternate promoters and splicing effects. PDEs primarily differ in their amino terminus which controls localization and regulation (Bender and Beavo, 2006; Houslay and Adams, 2003; Omori and Kotera, 2007). The majority of cAMP-hydrolyzing PDEs harbor PKA phosphorylation sites. Although the function of many sites remain unknown, in PDE3 and PDE4, PKA phosphorylation enhances catalytic activity, serving to provide negative feedback on cAMP levels. Interestingly, PDE3, whose cAMP-hydrolyzing activity can be competitively inhibited by cGMP, is regulated by phosphorylation from both PKA and the PI3K/AKT pathway downstream of hormone and growth factor receptors (Bender and Beavo, 2006). In the PDE4 family, the long isoforms contain a PKA phosphorylation site which can enhance PDE catalytic activity by 60%. PDE4B/C/D also have an ERK phosphorylation site that inhibits PDE activity. Activation of mitogen-activated protein kinase (MAPK) activity induces an initial increase in cAMP (through PDE inhibition) which by activating PKA, will in turn stimulate PDEs ultimately lowering cAMP levels again in a coordinated fashion. Conversely, short PDE4 isoforms, lacking the PKA phosphosite, are inhibited by ERK phosphorylation leading to increased cAMP, but this is complicated by differential upstream regulation of RAF-1 and BRAF by PKA (see *Section III, 3.5 Gas-PKA induced therapeutic resistance in cancer*) (Bender and Beavo, 2006; Houslay and Adams, 2003). Additionally, all PDE4 members can be recruited to β -arrestins to control GPCR/G protein-mediated signaling (Bender and Beavo, 2006). This fact may explain why

Figure 2. A) Signaling through the PKA pathway involves upstream activation of G α s-coupled G protein coupled receptors (GPCRs) which in turn activate adenylyl cyclase (AC) to produce cAMP. Activation of G α i-coupled GPCRs negatively regulate AC and cAMP production. Soluble AC (sAC) also contributes to cAMP production with activation by Ca²⁺ and HCO₃⁻. Levels of cAMP in the cell are controlled by production from various ACs as well as degradation by phosphodiesterases (PDEs). The PKA holoenzyme is a tetrameric complex consisting of two regulatory (R) subunits and two catalytic subunits (C). A kinase anchoring proteins (AKAPs) coordinate regulatory subunits and substrates. Additional binding domains present on AKAPs facilitated the formation of protein complexes and targeting to discrete locations around the cell. Binding of cAMP to regulatory subunits causes dissociation of the holoenzyme, releasing catalytic subunits to phosphorylate substrates. B) Expression of protein kinase A pathway components across normal tissues. Genes are grouped in families and expression level is represented as the median of transcripts per million (TPM)(GTex Portal). The heatmap displays expression from 0 to 200 TPM in blue and above 200 TPM in teal with darker shades representing higher expression values.

A

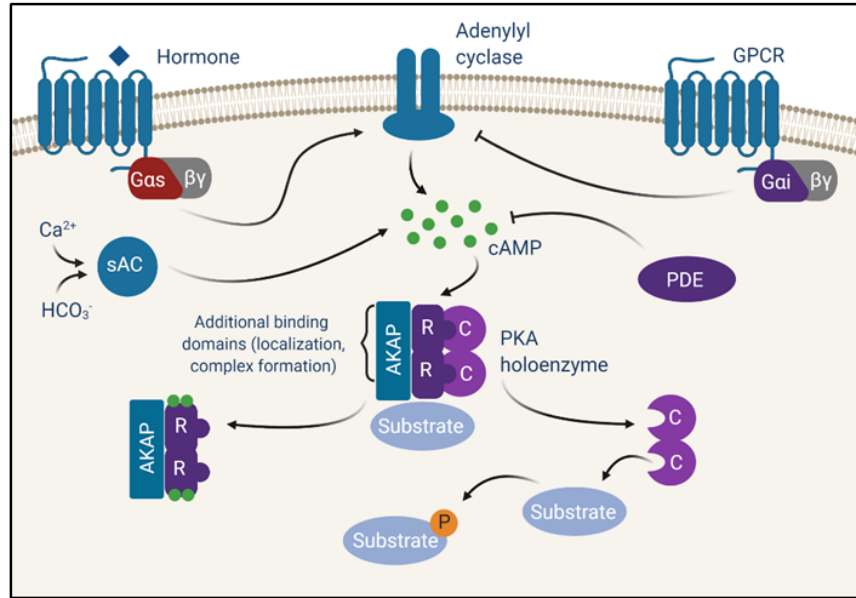

B

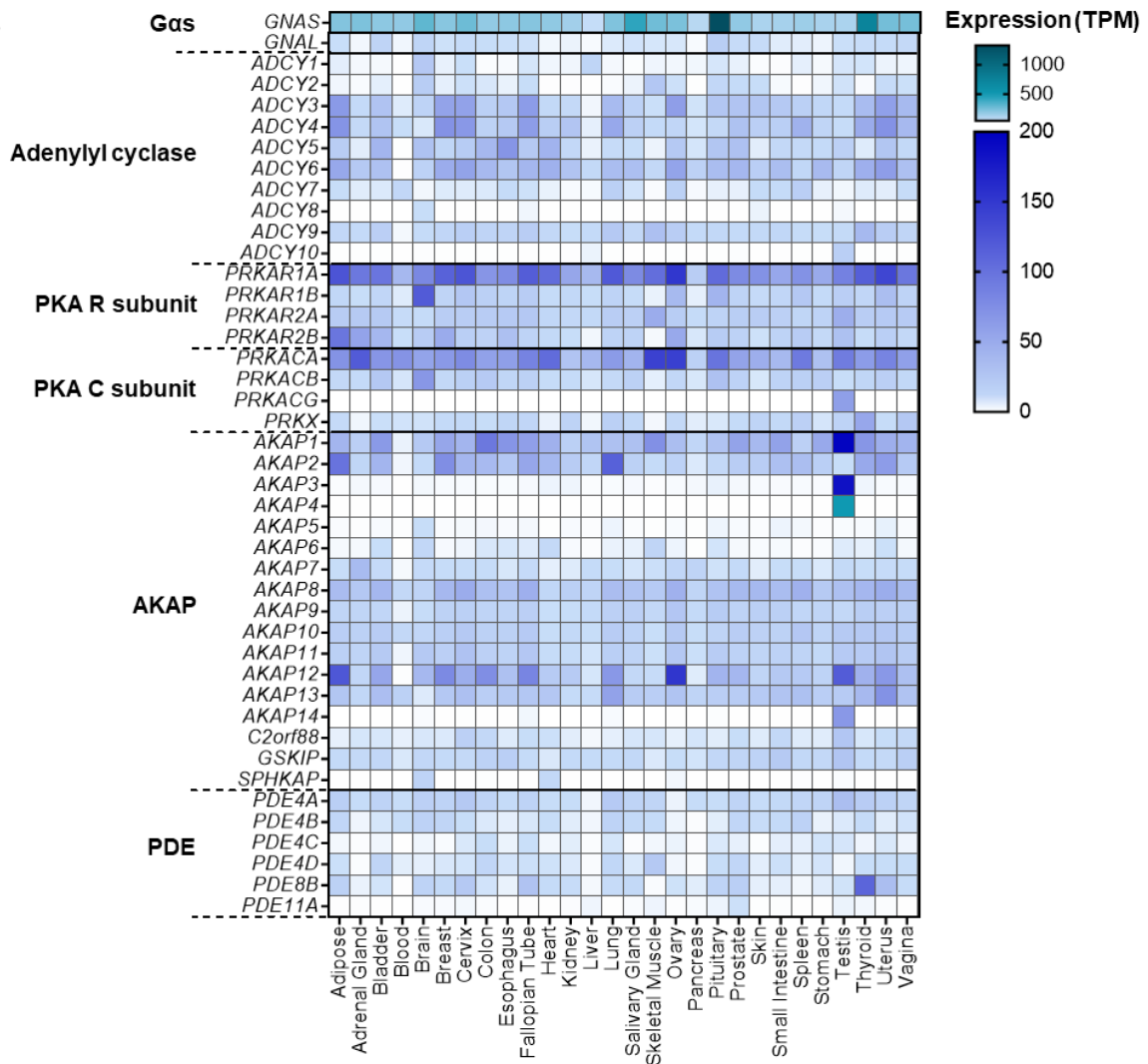

there seems to be a preference for PDE4 homozygous deletions in colorectal cancer, a tissue context that is responsive to GPCR-mediated prostaglandin signaling and pathway-dependent cell growth (see *Section III, 3.3 GNAS and PKA link inflammation to cancer initiation*). The function and roles of different PDE isoforms has been previously reviewed (Bender and Beavo, 2006; Blair and Baillie, 2019; DeNinno, 2012; Neves-Zaph, 2017; Omori and Kotera, 2007).

2. Regulatory subunits

The PKA regulatory subunits are each comprised of an amino terminal dimerization/docking (D/D) domain that is joined by an intrinsically disordered linker segment to two consecutive cAMP binding domains (CBDs) at the carboxyl terminus (Figure 1C). Of note, the four regulatory subunits are structurally similar, but have diverse expression patterns and are functionally non-redundant. RI α and RII α are ubiquitously expressed while RI β and RII β exhibit more tissue-specific expression (Kim et al., 2006) (Figure 2B, Table S1). The holoenzyme exists in an inactive state because the regulatory subunits' inhibitory sequence (IS), embedded within the linker region, occupies the active site of the catalytic subunit, acting as a pseudosubstrate or substrate (Figure 1C). The main difference between Type I (RI-containing) and Type II (RII-containing) holoenzymes is that the IS of RII subunits can be autophosphorylated while RI subunits act as pseudosubstrates. This has important implications for how the holoenzyme assembles and inhibits activity. Consequently, formation of a high affinity Type I holoenzyme requires the binding of ATP and two divalent metal ions (i.e. Mg²⁺) while Type II holoenzymes will form with high affinity independent of ATP binding (Amieux and McKnight, 2002; Herberg et al., 1999; Herberg and Taylor, 1993; Kim et al., 2006; Knape et al., 2017; Lu et al., 2019; Taylor et al., 2012; Walker et al., 2019; Wu et al., 2007).

3. Catalytic subunits

Upon cAMP binding to the regulatory subunits, the catalytic subunits become free to phosphorylate their substrates (Figure 2A). C α 1 and C β 1 are ubiquitously expressed while other C subunits and their splice variants display more limited, tissue-specific expression (Søberg and Skålhegg, 2018; Taylor et al., 2021; Turnham and Scott, 2016) (Figure 2B, Table S1). The catalytic subunit itself is composed of two lobes, a small N-lobe that contains the ATP binding site and a larger helix-rich C-lobe that is essential for substrate binding and coordinating the transfer of the phosphate from ATP to the substrate. The interface between the two lobes forms the active site cleft of the kinase (Knighton et al., 1991a) (Figure 1C). Under physiologic conditions the stable and fully active catalytic subunit is phosphorylated on its activation loop (Thr197) and C-terminal tail (S338) (Adams et al., 1995; Yonemoto et al., 1997). PKA facilitates the transfer of the gamma phosphate of ATP to serine or threonine residues preferentially in the context of the consensus Arg-Arg-x-Ser*/Thr*-hydrophobic motif, a phosphorylation motif that is quite similar to that of other AGC kinase family members (Bramson et al., 1984; Kemp et al., 1977).

4. PKA microdomains

Scaffolding molecules, known as A-kinase anchoring proteins (AKAPs), concurrently bind PKA regulatory subunits and protein substrates to form microdomains, or cAMP signaling islands, that facilitate substrate recognition, recruitment, and phosphorylation thereby enhancing PKA substrate specificity (Langeberg and Scott, 2015) (Figure 2A). Additional enzymes (kinases, phosphatases, GTPases), signal transducers (receptors, channels), and pathway regulators (PDEs) can also associate with AKAPs, contributing to their ability to modulate PKA signaling (Greenwald and Saucerman, 2011; Torres-Quesada et al., 2017). Together these AKAP-coordinated complexes facilitate the convergence and cross-talk of discrete signaling subnetworks. For instance, GSKIP is capable of binding the PKA substrate glycogen synthase kinase 3 β (GSK3 β) to control β -catenin-dependent signaling while AKAP11 binds GSK3 β to drive β -catenin independent signaling (Dema et al., 2016). Moreover, AKAP complexes coordinate

spatial specificity of the phosphorylation event and enable targeting of PKA activity to particular subcellular locations. Nearly 50 different AKAPs have been identified, but with differential expression patterns (Figure 2B, Table S1) and alternative spliceforms also adding to the diversity, many of their binding partners and physiologic roles are still not fully understood (Torres-Quesada et al., 2017). Detailed reviews of what is known about the role of AKAPs has been compiled previously (Bucko and Scott, 2020; Omar and Scott, 2020; Skroblin et al., 2010; Welch et al., 2010; Wong and Scott, 2004).

In addition to physically restricting substrate access, PKA signaling is also regulated spatially by controlling local cAMP pools. Historically, it was thought that these cAMP microdomains were generated by localized AC inputs and restrained by PDEs, impeding diffusion throughout the cell (Mika et al., 2012). Recent studies have challenged this concept, demonstrating that at physiologic concentrations, cAMP is largely in a bound state and only diffuses upon displacement from or saturation of binding sites (i.e. upstream receptor/AC stimulation). These binding sites buffer cAMP diffusion throughout the cell enabling PDEs to directly control cAMP compartments in their vicinity (10-60nm) (Bock et al., 2020). To this end, recent work has also shown that R1 α drives liquid-liquid phase separation as a mechanism to actively sequester cAMP, further contributing to cellular cAMP buffering (Zhang et al., 2020). Further supporting this concept of localized PKA activation, recent evidence has demonstrated that at physiological cAMP concentrations, the PKA holoenzyme (as assessed by AKAP79 and type II holoenzyme interactions) does not physically dissociate upon cAMP binding, but rather the catalytic subunits remains associated with AKAP and capable of phosphorylating substrates within its immediate vicinity (15 to 25nm) (Smith et al., 2017). Together these findings highlight even greater specificity of PKA activation than previous recognized. Importantly, disruption of this organization has been shown to drive aberrant PKA activity (Nikolaev et al., 2010; Zhang et al., 2020).

5. *Transcriptional regulation*

PKA is perhaps best known for its ability to phosphorylate and activate the CREB family of transcription factors, of which there are three members (CREB, CREM, and ATF-1, although CREM can act as a negative regulator). The function of CREB was originally described by its ability to drive the development of long-term memory, a process known to require gene transcription. At the time, cAMP and PKA had been shown to enhanced neurotransmission between sensory and motor neurons, contributing to short-term memory(Brunelli et al., 1976; Castellucci et al., 1980; Kandel, 2012). Subsequent work revealed that persistent activation of PKA and CREB-mediated transcription facilitated the transition from short-term to long-term memory(Alberini et al., 1994; Dash et al., 1990; Kandel, 2012). It is now known that upon activation, PKA translocates to the nucleus where it phosphorylates CREB on serine 133(Altarejos and Montminy, 2011; Rosenberg et al., 2002) (Bacskai et al., 1993) (Figure 3A). CREB phosphorylation recruits co-activators, CREB binding protein (CBP) or p300, through direct binding of the KIX domain present in CBP/p300 (Parker et al., 1996). Finally, CREB and CBP/p300 bind to cAMP response elements (CREs) in the genome to drive transcription of target genes(Altarejos and Montminy, 2011; Rosenberg et al., 2002)(Montminy et al., 1986). CBP and p300 are histone acetyltransferases that enhance the ability of CREB to activate transcription by relaxing the chromatin structure at gene promoter regions and creating scaffolds for recruitment of RNA polymerase II complexes to the promoter(Altarejos and Montminy, 2011; Kee et al., 1996). Another class of coactivators, the cAMP-regulated transcriptional co-activators (CRTCs), are also critical to enhancing CREB-mediated transcription. Under basal conditions, CRTCs are phosphorylated by SIK2 and AMPK kinases, and sequestered in the cytoplasm through phosphorylation-dependent interactions with 14-3-3 proteins(Altarejos and Montminy, 2011). CRTCs are dephosphorylated by phosphatases, including calcineurin, protein phosphatase 1 (PP1), and protein phosphatase 2A (PP2A), allowing them to translocate from the cytoplasm to the nucleus to facilitate CREB-mediated transcription (Figure 3A)(Altarejos and Montminy, 2011;

Figure 3. A) Protein kinase A drives CREB-mediated transcription. When hormone binds to Gas-linked G protein coupled receptors (GPCRs) on the cell surface, signaling through adenylyl cyclase stimulates cAMP production and PKA activation. Activation of G α i-coupled GPCRs inhibit adenylyl cyclase and cAMP production. When active, catalytic (C) subunits translocates to the nucleus to phosphorylate CREB on serine 133. Phosphorylated CREB recruits co-activators like CREB binding protein (CBP) to facilitate binding to cAMP responsive elements (CREs) and transcription of target genes. Additional co-activators, like cAMP-regulated transcriptional co-activators (CRTCs), help to regulate CREB-mediated transcription. Phosphorylation of CRTCs by other kinases results in cytoplasmic sequestration while dephosphorylation by phosphatase enables translocation to the nucleus. B) cAMP binds and activates effectors beyond PKA. Binding of cAMP to cyclic nucleotide gated (CNG) ion channels regulates channel opening and cation currents. Hyperpolarization-activated, cyclic nucleotide-modulated (HCN) channels also bind cAMP to facilitate channel opening by membrane hyperpolarization. cAMP binds to EPAC (Exchange Protein directly Activated by cAMP) to facilitate the exchange of GDP for GTP on the RAP family of small GTPases. Popeye domain containing (POPDC) proteins reside on the cell surface as dimers that bind cAMP.

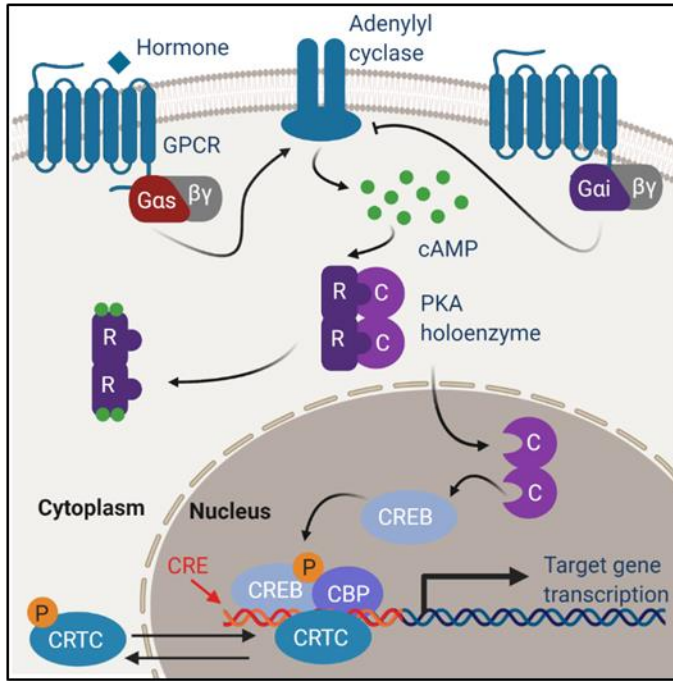
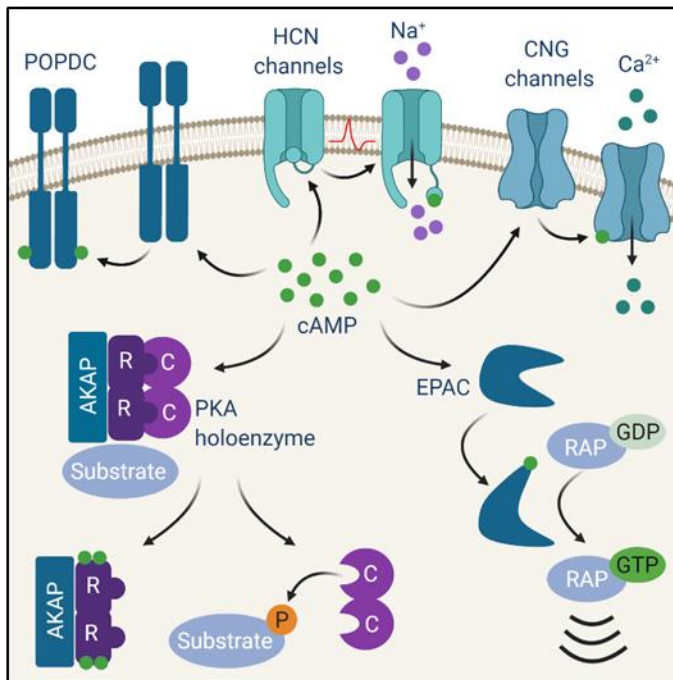
A**B**

Rosenberg et al., 2002; Sonntag et al., 2019). Of note, PP2A is emerging as a valuable therapeutic target in the treatment of PKA-driven cancers (see *Section IV, 4. Targeting the Gas-PA pathway signalopathies*).

Over 10,000 accessible CRE binding sites have been identified in humans, including some likely to represent alternative or bidirectional promoters. However, the majority reside within 200 base pairs of transcription start sites. Together, this accounts for regulation of over 4,000 genes (Impey et al., 2004; Zhang et al., 2005). Genes vary in their dependence on co-activators and CREB occupancy, ensuring that transcriptional activation is finely tuned to specific PKA stimuli (Altarejos and Montminy, 2011). CREB target genes highlight most of the key physiologic processes we will discuss, including regulation of PKA pathway activity, cell cycle entry, mitochondrial homeostasis, and metabolism (Figure 1A). Interestingly, many CREB target genes are themselves transcription factors (e.g., c-Jun, c-Fos, ICER), adding a temporal layer to the importance of PKA-driven transcription (Impey et al., 2004; Zhang et al., 2005). It is important to note, however, that PKA also regulates transcriptional programs independent of CREB. As we will discuss later, PKA phosphorylates components of other pathways (e.g., Wnt, Sonic hedgehog, Hippo) in order to regulate their transcriptional output (see *Section III, 3.3 GNAS and PKA link inflammation to cancer initiation and 3.4 GNAS-PKA as tumor suppressors*). Together, transcriptional effects and gene expression regulation permeate almost every role of PKA (physiological or aberrant).

6. Metabolic regulation

Another one of the major physiological roles of PKA is in regulation of glucose and lipid metabolism. Excess glucose in the body can be stored as glycogen (glycogenesis) in the liver or skeletal muscles. Coordinated activities of PKA (in response to glucagon or β adrenergic receptor) help to regulate the breakdown of glycogen and mobilization of glucose in times of low nutrient intake. For instance, PKA directly phosphorylates to inhibit glycogen synthase, one of the major

enzymes responsible for glycogenesis, while at the same time phosphorylates to activate glycogen phosphorylase kinase, one of the major enzymes responsible for glycogen breakdown(Han et al., 2016; Yang and Yang, 2016). When glycogen stores become depleted, PKA also participates in gluconeogenesis to elevate glucose levels. PKA acts through direct phosphorylation and regulation of enzymes participating in gluconeogenesis as well as transcriptional activation(Yang and Yang, 2016). The transcriptional response of PKA is mediated by CREB, and as such, siRNA knockdown of CREB in the liver decreases blood glucose levels and reduces expression of gluconeogenesis genes(Erion et al., 2009). Conversely, in a mouse model of CBP/CREB overactivity, gluconeogenesis is inappropriately activated during fed conditions leading to glucose intolerance(Zhou et al., 2004). Genetic mouse models activating PKA α and R1 α (dominant negative) also recapitulate these effects on glycogen and gluconeogenesis(Niswender et al., 2005; Willis et al., 2011; Yang and Yang, 2016).

Lipogenesis is another process by which glucose can be stored, in this case by conversion to fatty acids. Fatty acids are eventually stored as triglycerides in lipid droplets. When energy levels drop, fatty acids can be liberated by lipolysis. PKA is anchored to lipid droplets by an AKAP and known to activate lipolysis in adipose tissue through several mechanisms, most notably through phosphorylation of perilipin A(Rogne and Taskén, 2014; Yang and Yang, 2016). The so called “gatekeeper” of lipolysis, perilipin covers the outer surface of lipid droplets, preventing the action of lipases(Rogne and Taskén, 2014). PKA phosphorylates perilipin to induce conformational changes that allows lipases to access the lipid droplet(Brasaemle et al., 2008). PKA can also phosphorylate and activate the lipases adipose triglyceride lipase (ATGL) and hormone-sensitive lipase (HSL) which participate in the multistep process of lipolysis, converting triglycerides to free fatty acids(Rogne and Taskén, 2014; Yang and Yang, 2016).

As the G α s-PKA pathway is integral to many hormone-driven processes, it is not surprising that PKA is also heavily involved in steroidogenesis. Steroid hormones are small lipid signaling molecules derivative from cholesterol. PKA promotes cholesterol processing and steroid

biosynthesis both directly through modulation of enzymes (cholesterol ester hydrolase) and transcriptionally through phosphorylation and activation of transcription factors (CREB, steroidogenic factor 1, GATA-4)(Dyson et al., 2009; Manna et al., 2009). In addition to transcriptional regulation, PKA also regulates steroidogenic acute regulatory protein (StAR) post-translationally. StAR is important for transporting cholesterol into the mitochondria where it is processed. PKA phosphorylation is strictly required for activation of StAR, an event that is facilitated in part by AKAP1-anchoring of PKA to the mitochondrial outer membrane (Dyson et al., 2009; Manna et al., 2009).

Given the direct regulation of both glucose and lipid by the G α s-PKA pathway, many of the G α s-PKA pathway signalopathies have hyperglycemic or obesity-related phenotypes. For instance, mutational activation of PKA (as in Cushing's Syndrome) can lead to hyperglycemia and several pathway mutations are linked to development of diabetes mellitus(Sharma et al., 2015; Tengholm and Gylfe, 2017) (see *Section III, 2. Endocrine and metabolic diseases*). While these mechanisms provide some explanation for the phenotypes in many G α s-PKA pathway signalopathies it is important to recognize that PKA's role in metabolism is quite complicated, owing to the multilayer regulatory programs, including effects on enzyme activity, hormone secretion, and transcriptional responses.

7. Other cAMP effectors

It is important to note that while PKA is the major direct effector of cAMP, it is not the only one. When cAMP is free, it is capable of binding to and activating cyclic nucleotide gated ion channels, exchange factors, and popeye domain containing (POPDC) proteins (Figure 3B). These additional cAMP-dependent signaling mechanisms are briefly described below.

Cyclic nucleotide-gated (CNG) channels are ion channels that participate primarily in the sensory processes of sight and smell, converting second messenger signals to voltage changes (Brown et al., 2006). CNG channels are nonselectively permeable to cations, but the action of

Ca²⁺ predominates under physiological conditions. Unlike other gated ion channels, CNG channels are not subject to desensitization, rather they are regulated in their affinity for cyclic nucleotides. For instance, binding of Ca²⁺/calmodulin or posttranslational modifications can alter the channels' binding affinities. The various CNG channels also have differing innate affinities for cAMP versus cGMP, but in general cAMP is the dominant signal in olfaction (Bradley et al., 2005; Zagotta and Siegelbaum, 1996). Sensory GPCRs function as signal detectors in both sight and smell processes. Olfactory GPCRs couple to G_{olf} (encoded by *GNAL*), which functions like G_s to stimulate AC and cAMP production whereas rhodopsins (visual GPCRs) couple to transducin (G_{αt}) (encoded by *GNAT1*) to induce cGMP hydrolysis, explaining the importance of cAMP to olfaction (Julius and Nathans, 2012).

Another class of cyclic nucleotide-gated ion channels, known as hyperpolarization-activated, cyclic nucleotide-modulated (HCN) channels, function primarily at the sinoatrial (SA) node to maintain heartbeat. HCN channels are distinct from CNG channels in that they are regulated by membrane hyperpolarization in addition to binding of cyclic nucleotides (Biel, 2009; Brown et al., 2006). For HCN channels, the cyclic nucleotide binding (CNB) domain serves an autoinhibitory function by making the channel more difficult to activate (through hyperpolarization) in the absence of cAMP (Wainger et al., 2001). In the SA node, stimulation of the sympathetic nervous system increases cAMP and facilitates channel opening in response to membrane hyperpolarization after an action potential. When activated, HCN channels allow the influx of cations, contributing to the slow depolarization during diastole and priming the SA node for initiation of another action potential. HCN channels can also play a role in other excitable tissues like neurons (Biel, 2009; Brown et al., 2006).

While the roles of CNG and HCN channels are very specific for regulating currents, the roles of EPACs (Exchange Protein directly Activated by cAMP) are much broader. As guanine nucleotide exchange factors, EPACs activate the small GTPases RAP1 and RAP2. There are two EPAC proteins, EPAC1 and EPAC2 (encoded by *RAPGEF3* and *RAPGEF4*) which contain one

and two cAMP binding domains (CBDs), respectively. When cAMP binds to the CBD, a conformation change occurs to expose the critical residues that participate in the exchange of GDP for GTP to activate RAP1/2. EPAC1/2 are expressed in most tissues and by modulating RAP activity, they play important roles in cell adhesion in many contexts. Much like PKA signaling, EPAC signaling is compartmentalized and controlled by local cAMP pools. EPACs utilize their domain structures, DEP and RA domains, to target different cellular compartments and engage binding partners. Interestingly, PKA and EPAC participate in many of the same processes, with examples of both antagonistic and synergistic functions, and they have even been found in the same protein complexes. Of note, PKA is activated at much lower levels of cAMP than EPAC, providing another example of the dynamic responses to cAMP regulation (Gloerich and Bos, 2010).

The CBDs of PKA, CNG/HCN channels, and EPACs, are quite similar, but the Popeye Domain Containing (POPDC) proteins use a very different domain to bind cAMP, but still with a high affinity similar to that of PKA. POPDC proteins (encoded by *POPDC1*, *POPDC2*, and *POPDC3*) were named after “Popeye the sailor man” because they are highly expressed in striated muscle. POPDC proteins are heavily glycosylated and reside in the membrane where they are involved in cell-cell contacts, vesicular transport, and epithelial morphology. They are expressed in many tissues, but primarily studied in the context of cardiac function and epithelial cell organization. Importantly, their dysfunction, downregulation, and mutation have been associated with arrhythmias, muscular dystrophy, and epithelial to mesenchymal transition effects in cancer (Schindler and Brand, 2016).

II. Mutational landscape of the Gas-PKA pathway signalopathies

The Gas-PKA pathway signalopathies represent a diverse group of diseases and disorders characterized by dysregulation of the Gas-PKA pathway. As we will discuss in the next sections, the Gas-PKA pathway signalopathies are defined by mutations, predominately in the

Gαs subunit of GPCRs (encoded by *GNAS*) or the PKA holoenzyme (mainly *PRKACA* and *PRKAR1A*). Given the diversity of clinical phenotypes, many groups have aimed to understand the specific mechanisms of mutational activation (or inactivation). Here we will highlight what is known about the structural and functional significance of disease-associated mutations and integrate available data from inherited (Landrum et al., 2020) and somatic mutation databases (Kim and Zhou, 2019; Tate et al., 2018) to identify broader mutational themes that contribute to the Gαs-PKA pathway signalopathies. Of note, in addition to drawing from publically available databases, we also aim to highlight examples of mutational themes identified from the literature.

1. Mutations in *GNAS*

Mutations in *GNAS* are dominated by hotspot mutations at two residues, R201C/S/G/H/L and Q227L/K/R/H (Figure 4A, Table S2 and S3). These residues are conserved across Gα subunits and reside within the “switch I” and “switch II” regions, respectively, which universally characterize GTPases, including small GTPases of the Ras superfamily. “Switch I” and “switch II” respond to changes in GTP and GDP binding by sensing the presence or absence of the gamma phosphate (Figure 4B and 4C). These residues are essential for GTPase activity and thus their mutation results in impaired GTPase function and constitutive activity (O'Hayre et al., 2013; Sprang, 2016; Sunahara et al., 1997). Recent work has also suggested that *GNAS* R201C may be capable of activating adenylyl cyclase and downstream signaling even in the presence of GDP, an event that is normally restricted to the GTP bound state (Hu and Shokat, 2018). Interestingly, R201 mutations are far more prevalent in human disease than Q227 (Arang and Gutkind, 2020; O'Hayre et al., 2013). This discrepancy is most striking in cancer where nearly 50% of all *GNAS* mutations are at R201 while only 2% are at Q227 (Figure 4A, Table S3). Little is known about why this preference occurs, but it could be linked to the biological activity of the mutation as is the case for another G protein, Gαq (encoded by *GNAQ*). For instance, uveal melanoma, the most common cancer of the eye, is almost exclusively caused by *GNAQ* mutations at residue Q209

Figure 4. *GNAS* mutational themes in disease. A) Lollipop plots depict the location of *GNAS* mutation along the gene body in genetic diseases. Both activating and inactivating mutations are depicted. The height of the lollipop is representative of pathogenic mutation number (ClinVar database)(Landrum et al., 2020). Below the gene body, colored circles depict the location of cancer mutations (COSMIC database)(Tate et al., 2018). The frequency of residue mutation (residue representing >1% of all *GNAS* mutations) is shown with darker blue representing a larger proportion of *GNAS* mutations occurring at that residue. Hotspot mutations in the switch I and switch II domains are dominant in both genetic diseases and cancer. B) Structure of the prototypical β_2 adrenergic receptor (β_2 AR) coupled to the heterotrimeric Gas G protein (PDB: 3SN6). Pathogenic mutations are shown in red spheres. Recurrent mutations are present in the nucleotide binding pocket. Other mutations are present at the receptor-G protein interface and in residues interacting with the G $\beta\gamma$ subunits. C) Structure of Gas binding to adenylyl cyclase (PDB: 1AZS) highlights the mutations clustered in the nucleotide binding pocket (switch I and switch II).

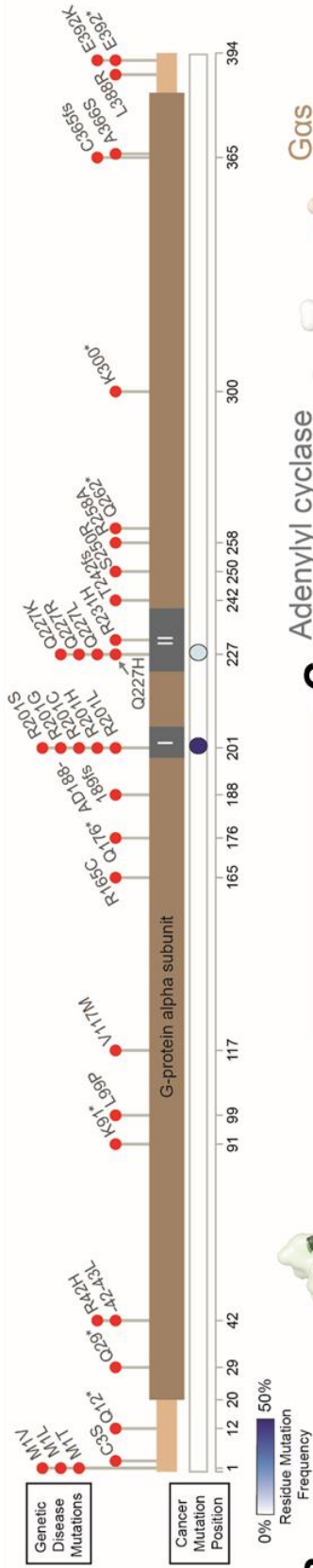
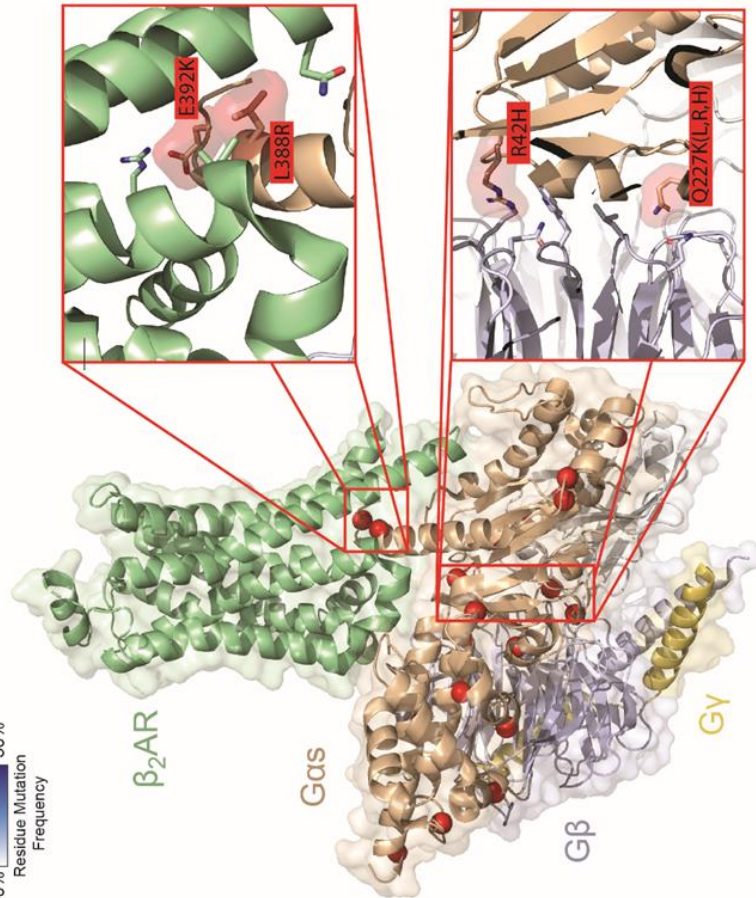
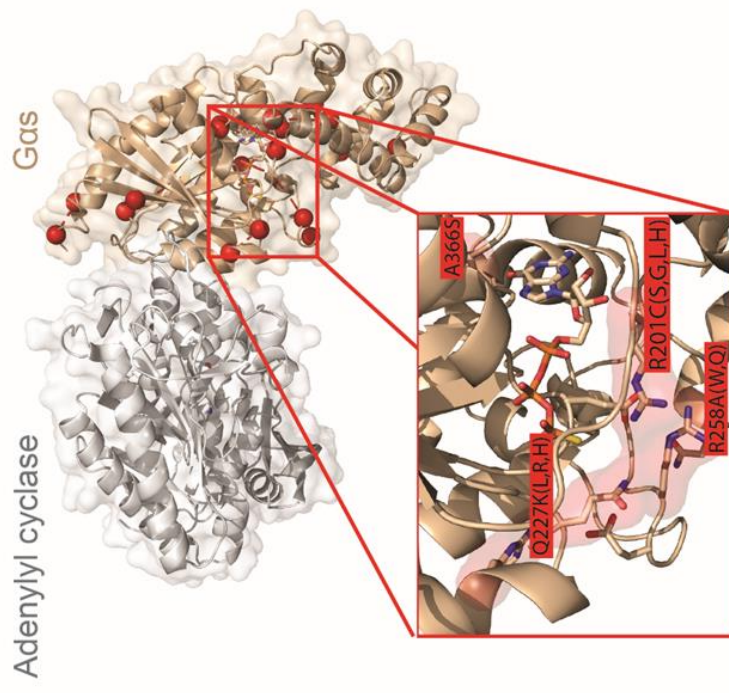
A**GNAS****B****C**

(corresponding to *GNAS* Q227). Whereas Sturge-Weber Syndrome, characterized by angiomas or tumors of small blood vessels, is caused by *GNAQ* R183 mutations (corresponding to *GNAS* R201). *GNAQ* R183 mutants are responsive to signal termination by regulator of G protein signaling (RGS) proteins, whereas Q209 mutants are not. This highlights that Q209 mutants are more active and consequently drive more extensive proliferation (Arang and Gutkind, 2020; O'Hayre et al., 2013; Shirley et al., 2013). Unlike *Gαq*, *Gas* does not bind RGS proteins as a mechanism to turn off signaling (Natochin and Artemyev, 1998a; b). Additionally, *GNAS* Q227 mutants having higher intrinsic activity than R201 mutants, contributing to greater proliferation and secretion (Ham et al., 1997; Landis et al., 1989). In the case of *Gas*, fine-tuned regulation is critical as too much or too little activity can be incompatible with life (Khan et al., 2018; Yu et al., 1998). Together, these findings suggest that Q227 mutations may not be tolerated in many contexts, thus R201 mutations may be biologically selected.

Similar to mutations, spliceforms of *Gas* also seem to contribute to this tight regulation of activity, with differential splice preference in disease states, such as obesity, hypertension, and diabetes (Novotny and Svoboda, 1998). The long isoform (inclusion of exon 3) has a lower binding affinity for GDP, making it more easily exchanged for GTP and therefore more easily activated (Seifert et al., 1998). In fact, coupling of the long isoform to the glucagon receptor, enhances glucagon binding affinity as much as 10-fold (Unson et al., 2000). Despite these findings, the direct disease causing ability of either spliceform has yet to be established. Finally, while diseases may have preferential ways to activate *Gαs*, mutation of many different residues can disable *Gαs* activity, as missense mutations have been found in almost every exon of *GNAS*, with many of them leading to truncation mutations and haploinsufficiency (Weinstein et al., 2004) (Figure 4A, Table S2). Of note, there are also point mutations at the receptor-G protein interface (E392K and L388R) that are likely loss of function based on the patients' clinical phenotype, suggesting that disruption of receptor-G protein contacts represent another mutational

mechanism (Figure 4B). Ultimately these data highlight that achieving the proper balance of Gαs activity is critical and thus its dysregulation is closely tied to disease.

2. Mutations in PKA catalytic subunits

Since PKA functions as a holoenzyme, the mutational themes in PKA are quite different than the hotspot mutations we observe in Gαs. Among the Gαs-PKA pathway signalopathies, Cushing's Syndrome caused by adrenocortical adenomas is the disease most commonly caused by mutations in PKA catalytic subunits and serves as an excellent example of activation themes exploited by mutations (see *Section III, 2.2 Cushing's Syndrome and adrenocortical adenomas*). Likely due to its ubiquitous expression and functional roles in many tissues (Figure 2B, Table S1), the majority of mutations occur in *PRKACA* or Cα. As mentioned previously, each catalytic subunit is composed of two lobes, the N-lobe harboring the ATP binding site and the C-lobe responsible for substrate binding (Figure 1C and 5A). The interface of these two lobes forms the active site, an interaction that is largely mediated by the binding of ATP and facilitates the opening and closing of this active site cleft along with substrate engagement. This interface also contacts the inhibitory sequence (IS) that is embedded in the intrinsically disordered linker region of each regulatory subunit (Figure 1C and 5B). When the holoenzyme is inactive, the IS is locked into the active site of the C subunit which prevents the binding of substrates (Johnson et al., 2001; Taylor et al., 2012). A sequence similar to the IS is also found in protein kinase inhibitor (PKI) isoforms where it also acts as a pseudosubstrate. Briefly, PKIs are endogenous peptide inhibitors of PKA that are expressed in a variety of human tissues. When catalytic subunits are free, PKIs bind to and block PKA activation in response to cAMP, primarily operating in the cytoplasm or nucleus (Liu et al., 2020) (see *Section IV, 2.2 Peptide Inhibitors of the catalytic subunit*).

The most frequent mutation in PKA Cα is L206R, which lies near the interface of the N- and C-lobes, and contributes to the R:C interface as well as substrate recognition (Figure 5A and 5B, Table S2 and S3). Consequently, this mutation disrupts critical contacts and leads to PKA

Figure 5. Protein kinase A mutational themes. A) Lollipop plots of *PRKACA* pathogenic mutations in genetic diseases (ClinVar database)(Landrum et al., 2020). The frequency of residue mutation in cancer (residues representing >1% of all *PRKACA* mutations) are depicted below (COSMIC database)(Tate et al., 2018). Darker blue represents that a greater proportion of *PRKACA* mutations occur at that residue. B) Structure of C α in complex with RI α (PDB: 5JR7). Pathogenic mutations are depicted as red spheres. *PRKACA* mutations lie at the interface of the catalytic and regulatory subunits while *PRKAR1A* mutations are distributed throughout the protein. C) As in A) lollipop plots of genetic disease mutations in *PRKACB* and frequency of residue mutation in cancer below. D) Structure of the R binding domain of AKAP10 in complex with RI α (PDB: 3IM4) (dotted line connects to the same region of RI α as shown in B). Mutations of unknown significance (shown in yellow) reside within the D/D domain that mediates regulatory subunit dimerization and A kinase anchoring protein (AKAP) binding. E) As in A) and C) lollipop plots and cancer residue frequency illustrate that no recurrent mutations occur in *PRKAR1A*.

activation by multiple mechanisms(Walker et al., 2019). First, the L206R mutation disrupts interactions between C α and the regulatory subunits, leading to constitutive activity even in the absence of cAMP(Calebiro et al., 2014; Röck et al., 2015). L206 (or 205 depending on numbering conventions), along with other residues, is part of a hydrophobic pocket that binds substrates as well as the regulatory subunits' IS (Figure 5B). Introduction of a more bulky, positively charged residue disrupts this hydrophobic interaction sterically and chemically(Calebiro et al., 2014; Moore et al., 2003; Taylor et al., 2012). As alluded to previously, the residues in the active site are critical for controlling the activity and regulation of C α as well as for substrate recognition. They are not only important for intermolecular contacts, but also for intramolecular or allosteric interactions. By measuring chemical shift perturbations through NMR, it is evident that wild-type and L206R C α have dramatically different allosteric networks that alter the normal binding cooperativity between ATP and substrates. Ultimately this results in an inability of L206R to achieve a fully closed state. Similarly, molecular dynamics simulations reveal that L206R has a much broader conformational range than wild-type C α . Together the disruption of normal allosteric interactions and protein conformations results in an altered substrate specificity(Walker et al., 2019). This altered substrate profile includes decreased activity towards canonical substrates and increase activity towards non-canonical substrates, particularly those with negatively charged (instead of hydrophobic) residues after the consensus phosphorylation motif (Arg-Arg-x-Ser*/Thr*-hydrophobic). While the intrinsic activity of the C α L206R does not seem to differ from the wild-type, the altered substrate profile may contribute to aberrant signaling (Bathon et al., 2019; Calebiro et al., 2014; Lubner et al., 2017; Luzi et al., 2018; Walker et al., 2019).

Most Cushing's Syndrome mutations as well as cancer mutations in C α (W197, L199_C200insW, C200_G201insV, S213R, E249Q) are located in the C-lobe near the active site cleft and contribute to peptide recognition. This region also includes the binding surface for the regulatory subunits (Figure 5A, Table S3). Due to their location in this critical region it is thought that these mutations achieve PKA activation through mechanisms similar to L206R(Luzi et al.,

2018; Walker et al., 2019). The E32V mutation is the only mutation that resides away from the active site, but given the broad conformational impacts elicited by the other Cushing's mutations, it is possible that E32V may also disrupt this intramolecular network(Walker et al., 2019). Recently, additional point mutations in both *PRKACA* and *PRKACB* have been described in several G α s-PKA pathway signalopathies, including Cushing's Syndrome. Like many of the C α mutations mentioned above, C β mutations S54L and H88R/N are located in a region critical for ATP and substrate binding near the active site. Interestingly, S54L and H88R/N both show increased sensitivity to cAMP due to reduced stability of the respective PKA holoenzymes and C:PKI interactions(Espiard et al., 2018; Palencia-Campos et al., 2020; Taylor et al., 2021) (Figure 5C, Table S2 and S3). Similarly, other recently characterized mutations C α G137R and C β G235R have reduced affinity for regulatory subunits and consequently increased PKA kinase activity at low cAMP levels. Although C α G137R and C β G235R do not affect ATP binding, they do reside in the area that makes contacts with regulatory subunits as well as PKI(Palencia-Campos et al., 2020)(Figure 5A, B, and C, Table S2). Together these mutations highlight holoenzyme destabilization or defects in PKI signaling as alternative mechanisms to enhance PKA activity without altering intrinsic kinase activity(Espiard et al., 2018; Palencia-Campos et al., 2020).

3. Mutations in PKA regulatory subunits

Destabilization of the PKA holoenzyme and disruption of regulatory-catalytic subunit contacts is the major mutational theme underlying the G α s-PKA pathway signalopathies. While we have already discussed the role of catalytic subunits in these interactions, mutation of regulatory subunits is actually the most frequently observed alteration (Figure 5B, D, and E, Table S2). In fact, over 130 molecular defects in *PRKAR1A*, or R1 α , have been associated with G α s-PKA pathway signalopathies (PRKAR1A Mutation Database, <https://prkar1a.nichd.nih.gov/>). As is the case for PKA C α , most mutations occur in R1 α likely due to its ubiquitous expression and functional importance in many tissues(Figure 2B, Table S1). These mutations span the length of

the protein, ranging from missense mutations and premature stop codons to insertions and deletions, with deletions as large as 4kb described(Horvath et al., 2010; Horvath et al., 2008; Kirschner et al., 2000a). The loss of function nature explains why there are no recurrent mutations in *PRKAR1A* found in cancer (Figure 5E, Table S3). This pattern of gene mutations throughout the gene length is well-established for known tumor suppressor genes in cancer(Vogelstein et al., 2013). Mutations may lead to altered function, alternative protein expression, and even absence of protein. Many of the premature stop codons or small insertions and deletions lead to nonsense mediated decay (NMD), representing 90% of *PRKAR1A* mutations(Bertherat et al., 2009; Greene et al., 2008; Horvath et al., 2010). NMD occurs at the mRNA level as a normal quality control mechanism to prevent the translation of truncated proteins. Strong NMD mutations typically occur at least 50 base pairs upstream of the final exon-exon junction(Brogna and Wen, 2009). For these NMD mutations, the mutant protein is not expressed leading to 50% reduction in R1 α protein and consequently haploinsufficiency. PKA activity is ultimately enhanced due to disruption of the normal holoenzyme stoichiometry(Horvath et al., 2010). Alterations that occur in the last exon actually escape NMD and are translated(Veugelers et al., 2004). Interestingly, some of these mutations, specifically those coding for an elongated protein, are subject to proteasomal degradation and result in haploinsufficiency as well(Patronas et al., 2012).

While most *PRKAR1A* mutations result in haploinsufficiency due to mRNA NMD or protein degradation, the mutations that successfully evade these quality control mechanisms, forming alternative R1 α protein, actually contribute to more severe disease(Horvath et al., 2010; Meoli et al., 2008). On a biochemical level, they are also incredibly informative of PKA holoenzyme dynamics. For instance, there are two regions of R1 α that are critical to catalytic subunit binding, one of which is within the first cAMP binding domain (CBD-A) (Figure 5B and 5E). Disruption of this interaction site by mutation, results in increased PKA activity independent of cAMP levels as the mutant R1 α is unable to bind the catalytic subunit(Greene et al., 2008; Meoli et al., 2008). This is mirrored by large deletions that result in deletion of exon 3 which contains the inhibitory

sequence (IS), the other region critical to catalytic subunit binding (Greene et al., 2008; Horvath et al., 2008). There are also several mutations (D183Y, A213D, and G289W) that reside within the two cAMP binding domains (CBD-A and CBD-B) and have decreased binding affinity for cAMP, but greater overall PKA activity. Other mutations, exhibiting the same biochemical phenotype, have been identified in critical regions such as the dimerization/docking (D/D) domain (S9N) which alters protein conformation and disrupt the communication between the D/D domain and the CBDs (Greene et al., 2008; Hamuro et al., 2004). These types of mutations may also disrupt AKAP scaffolding interactions as the D/D domain mediates these contacts (Figure 5D and E). As mutations occur throughout the R1 α protein, it is thought that many of the missense mutations located outside of functional domains may contribute to PKA activation through similar disruption of conformational communication (Greene et al., 2008; Hamuro et al., 2004; Veugelers et al., 2004).

Most of the R1 α mutations we have discussed so far result in increased PKA activity. Conversely, there is a whole class of R1 α mutations that suppress PKA activity, leading to different pathologies. Given the underlying importance of holoenzyme stability, it is not surprising that these mutations stabilize the holoenzyme, often rendering it less sensitive to dissociation by cAMP. To this point we observe many of the acrodysostosis mutations (discussed further in *Section III, 2.7 Inactivating PTH/PTHrP signaling Disorder*) cluster in the C-terminus of the protein, the region where the two CBDs reside (Figure 5E). Point mutations within the CBDs (CBD-A: Y175C, A213T and CBD-B: Q285R, G289E, A328V, R335L) as well as partial deletion of CBD-B (R368X, Q372X) make R1 α resistant to cAMP, dampening PKA activity (Bruystens et al., 2016; Linglart et al., 2011; Rhayem et al., 2015). CBD-B is particularly important because binding of cAMP to CBD-B results in a conformation change that exposes CBD-A (Kim et al., 2007). Perhaps the most interesting finding is related to residues A213 and G289. As mentioned previously their mutation decreases cAMP binding, however, depending on the residue this can lead to completely different clinical presentations. A213T and G289E result in acrodysostosis and inhibit PKA activity

while A213D and G289W result in Carney Complex disease and activate PKA activity. Interestingly, while all mutations display decreased cAMP binding, R1 α G289W is rapidly degraded, resulting in PKA activation. R1 α A213D on the other hand has a reduced degradation rate, but appears to become inappropriately activated without holoenzyme dissociation and at extremely low cAMP levels. Of note, this increased activity is comparable with R1 α WT at low cAMP levels, but completely lost at high levels of cAMP (Rhayem et al., 2015).

4. Fusion proteins: an emerging mutational theme

As we discussed in the previous two sections, there are many mechanisms to disrupt normal PKA regulation and stability. The unexpected discovery of PKA fusion proteins in cancer has added yet another mechanism to the list. In 2014, Honeyman, *et al.* revealed that fibrolamellar hepatocellular carcinoma (FL-HCC) patients express a chimeric RNA transcript that fuses the J domain of the molecular chaperone DNAJB1 in frame with PKA C α (*DNAJB1-PRKACA*) due to a ~400kb deletion on chromosome 19 (Honeyman et al., 2014) (Figure 6A). On a molecular level, the fusion protein retains kinase activity (Honeyman et al., 2014; Riggle et al., 2016) and normal contacts with PKI (Cheung et al., 2015), and R1 α (Cao et al., 2019) and R1I β (Lu et al., 2021) regulatory subunits. The fusion protein also retains interactions with AKAPs (including atypical AKAPs that associate with the amino terminal region of C α) (Cheung et al., 2015; Riggle et al., 2016), and even interactions with HSP70 through the fused J domain (Turnham et al., 2019). Surprisingly, however, the fusion protein does disrupt normal R1 α -mediated liquid-liquid phase separation and cAMP compartmentalization, potentially contributing to its oncogenic activity (Zhang et al., 2020). Furthermore, because the fusion protein is expressed from the DNAJB1 promoter, it results in relative overexpression compared to wild-type PKA C α , which may be augmented by enhanced mRNA stability due to loss of 3' UTR regulation (Riggle et al., 2016). While the fusion protein maintains similar intrinsic kinase activity, the DNAJB1-PRKACA fusion protein may also achieve increased PKA activity due to increased responsiveness to cAMP, likely

Figure 6. A) Protein kinase A catalytic subunit fusion proteins identified in cancer. Colored lines on chromosome 1 indicate the genomic position of *PRKACB* and *ATP1B1* (green). Chromosome 19 harbors *DNAJB1* (red) and *PRKACA* (purple). Exon 1 of *DNAJB1* or *ATP1B1* is fused at the same position in *PRKACA* and *PRKACB* (exon 2-10). B) RET/pct2 fusion protein identified in papillary thyroid cancer fuses the N-terminus of *PRKAR1A* on chromosome 17 (orange), including the dimerization/docking (D/D) domain, with the tyrosine kinase domain of RET on chromosome 10 (pink). Two tyrosine residues are essential for mitogenic activity and participate in scaffolding interactions. C) Prevalence of PKA pathway fusion proteins across cancer types (Fusion GDB)(Kim and Zhou, 2019). Among pathway genes, *GNAS* is the most common fusion partner.

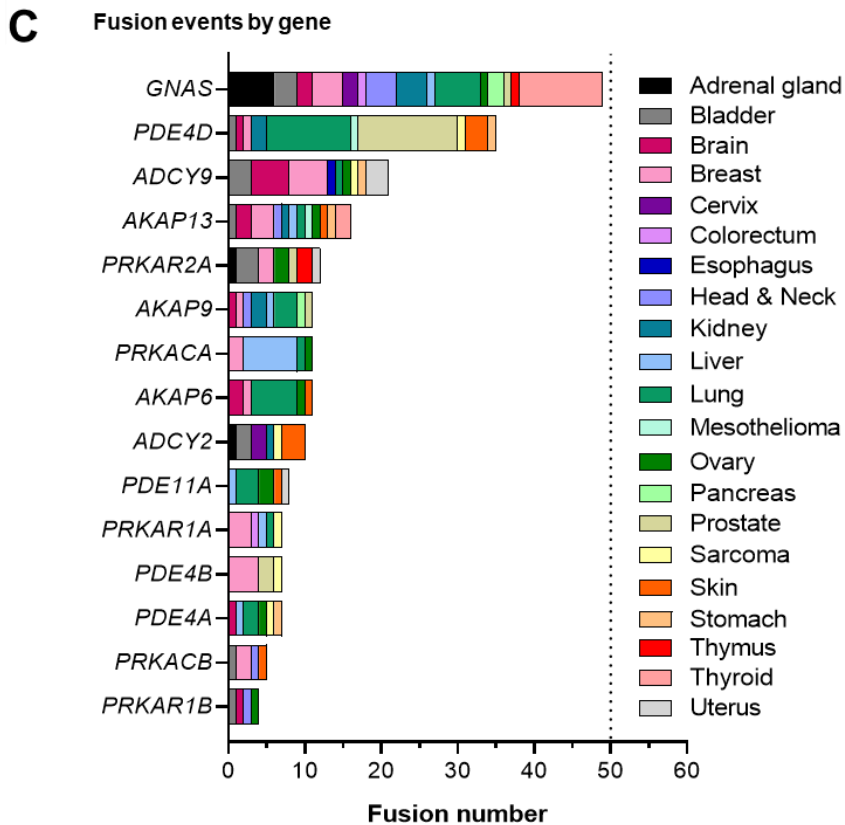
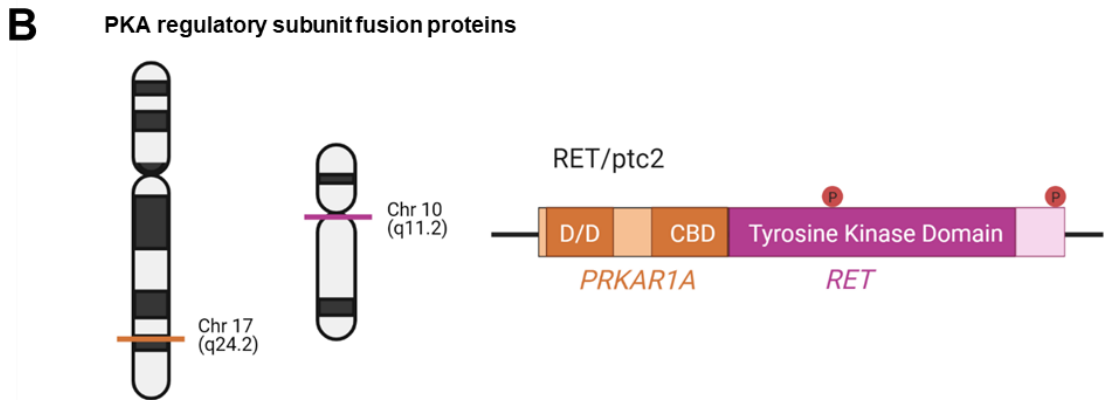
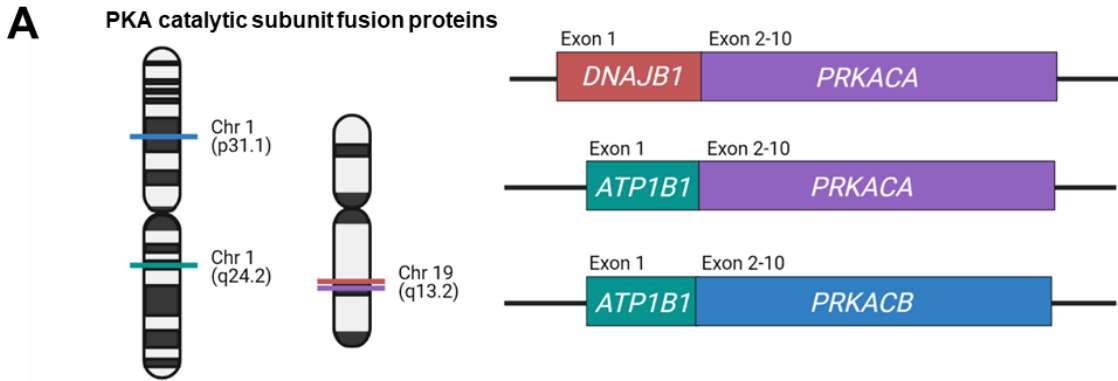

due to decreased holoenzyme stability and/or disruption of allosteric regulation(Cheung et al., 2015; Lu et al., 2021; Riggle et al., 2016). Importantly, the dynamic features of the PKI complex are also significantly altered(Olivieri et al., 2021). Recently, additional PKA fusion proteins involving ATP1B1 as the N-terminal fusion partner (ATP1B1-PRKACA and ATP1B1-PRKACB) have also been described to share a similar breakpoint as DNAJB1-PRKACA and exhibit increased catalytic subunit expression due use of the ATP1B1 promoter(Nakamura et al., 2015; Singhi et al., 2020; Vyas et al., 2020) (Figure 6A).

While the PKA catalytic subunit fusion proteins are certainly the most striking examples, they are not the only fusion proteins that exist within the PKA pathway. In papillary thyroid cancers, fusions of *PRKAR1A* and the *RET* receptor tyrosine kinase have been described. Termed RET/ptc2, these chimeras fuse the N-terminus of R1 α with the tyrosine kinase domain of RET(Lanzi et al., 1992) (Figure 6B, Table S4). Interestingly, the dimerization/docking (D/D) domain is the most important region of R1 α required to mediate mitogenic activity when fused to the RET tyrosine kinase domain. Since R1 α exists as a dimer, it is believed that the D/D domain facilitates fusion protein dimerization (a required step in normal receptor tyrosine kinase activation) and subsequent activation of RET as the same proliferative effects can be observed with substitution of the EGFR tyrosine kinase domain for that of RET(Durick et al., 1996; Durick et al., 1995). In fact, the contribution of dimerization domains from N-terminal fusions partners is well documented to drive constitutive dimerization and activation of other receptor tyrosine kinase fusion proteins(Nelson et al., 2017). Interestingly, there are two tyrosine residues conserved within the RET portion of the fusion protein that are also essential to mitogenic activity likely due to their participation in scaffolding interactions when phosphorylated(Durick et al., 1996; Durick et al., 1995)(Figure 6B). Although the effect of RET/ptc2 on PKA signaling is still unknown, given the importance of the Gas-PKA pathway in thyroid pathophysiology, RET/ptc2 fusion could be a mechanism whereby activation of an oncogene (*RET*) and inactivation of a tumor suppressor (*PRKAR1A*) function together to drive transformation(Santoro and Carlomagno, 2013).

Given our mechanistic understanding of PKA fusion proteins, it is surprising that *GNAS* is actually the most common fusion partner, with fusion proteins present across many cancer types (Figure 6C, Table S4). While little is known about the function of these fusion proteins, the prevalence in highly pathway-dependent cancers, such as those of the adrenal and thyroid glands, suggest that they could be functionally active in some way. While *GNAS* lacks a truly recurrent fusion partner like *DNAJB1-PRKACA*, there are still some patterns that emerge. Interestingly, the majority of breakpoint cluster at similar genomic coordinates, fusing the 5' coding sequence of *GNAS* with another gene. In addition to *GNAS*, other common pathway fusion partners include *PDE4D* and *ADCY9* (Figure 6C, Table S4). While these findings are certainly intriguing, much work is still required to understand if these fusion proteins are expressed and functionally important. As we have seen with other mutations in the pathway, degradation (i.e. NMD of *PRKAR1A* mutants) could also be an important mutational mechanism utilized by fusion proteins.

5. Expanding the mutational themes

While the G α s-PKA pathway signalopathies are dominated by somatic and germline mutation of the key signaling nodes, *GNAS*, *PRKACA*, and *PRKAR1A*, additional mechanisms of pathway dysregulation continue to emerge, representing additional disease phenotypes (Figure 7A, Table S2). Mutations in several phosphodiesterase enzymes (PDEs) have been reported in G α s-PKA pathway signalopathies characterized by both pathway activation and inhibition (see *section III, Human G α s-PKA pathway signalopathies*). Further analysis is required to better understand the function and prevalence of these types of mutations in disease. As we highlight through this review, the role of specific GPCRs reaches across many G α s-PKA pathway signalopathies. Recent studies have begun to understand the patterns of mutation in GPCRs, highlighting the importance of critical regions like the DRY and NPxxY motifs in altering activity (Raimondi et al., 2019). This is a promising area of research from both a biological and

Figure 7. A) Network map of protein kinase A pathway mutations in genetic diseases. Outline of each node shows the functional significance of corresponding mutations with benign variants or variants of unknown significance in green and pathogenic mutations or risk factors in red. Size of the node represents the number of mutations classified as pathogenic, likely pathogenic, or risk factor in ClinVar(Landrum et al., 2020). Pie charts within the node are colored by frequency of disease phenotypes associated with mutations in each node. Solids edges represent known functional interactions (FIs) with arrows indicate some form of regulation exists between the nodes. Dashed edges represent FIs predicted by Reactome and dotted edges indicate FIs predicted by STRING (score >0.75). Disease phenotype abbreviations: Lethal congenital contracture syndrome 8 (LCCS8), Body Mass Index Quantitative Trait Locus 19 (BMIQ19).

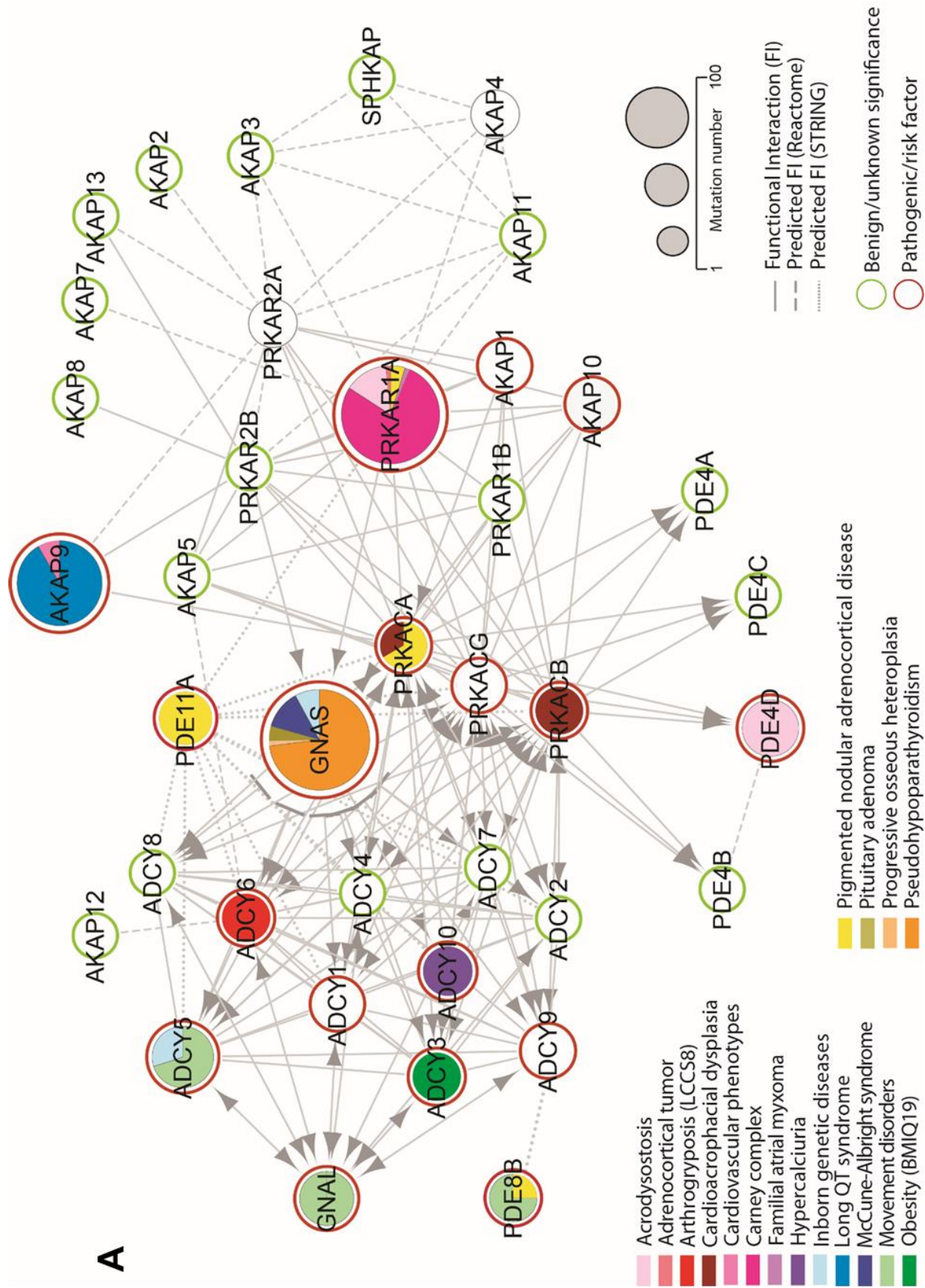

therapeutic perspective, helping to differentiate between passenger mutations and disease drivers. Additionally, mutations in the other subunits of the heterotrimeric G protein (i.e. *GNB1*), have been described as functionally significant (Brockmann et al., 2017; Zimmermannova et al., 2017). Unlike GPCRs and G proteins, the role of mutations in AKAP scaffolds remain largely unexplored. A prime example of the functional importance of AKAP9 mutations is in long-QT syndrome (Figure 7A, Table S2), where patients suffer from irregular heartbeat due to issues with ionic currents in the heart. AKAP9 forms a critical complex with a potassium channel subunit, KCNQ1. Phosphorylation of KCNQ1 by PKA is required for repolarization after a cardiac action potential. The S1570L mutation in AKAP9 disrupts the KCNQ1 interaction, reduces phosphorylation, and most importantly renders the potassium channel functionally unresponsive to cAMP (Chen et al., 2007). Several reports have documented mutations in other pathway components, including *PRKAR1B*, a mutation thought to disrupt catalytic or AKAP binding, as well as gain of function mutations in *ADCY5* (Figure 7A, Table S2). To date, these mutations have primarily been observed in neurological and neurodegenerative diseases such as familial dyskinesia and Alzheimer's disease (Chen et al., 2014; Marbach et al., 2021; Wong et al., 2014). While we focus primarily on endocrine and neoplastic diseases in this review due to the strength of data linking genetics to disease mechanism, the role of PKA in neurological diseases is certainly an emerging family of Gas-PKA pathway signalopathies. For instance, PKA dysregulation may contribute to Alzheimer's, Huntington's and Parkinson's diseases, but these disease mechanisms and their therapeutic opportunities are still poorly understood (Dagda and Das Banerjee, 2015; Greggio et al., 2017).

Overt mutation and genomic alteration is not the only mechanism of pathway dysregulation. We have already discussed the potential role of aberrant splicing in *GNAS*, but many members of the Gas-PKA pathway are subject to regulation by splicing, including tissue-specific isoforms of PKA catalytic subunits (Søberg et al., 2017) and signalosome-specific AKAP spliceforms (Wong and Scott, 2004). Furthermore, recent work has suggested that disease

phenotypes may be associated with single nucleotide polymorphisms (SNPs) in specific GPCR isoforms (Marti-Solano et al., 2020). As we will discuss later, the role of autocrine and paracrine (oncochrine) pathway activation can also contribute to aberrant signaling. Overproduction of pathway ligands can certainly contribute to disease, as is the case for COX-2 overexpression-driven PGE₂ production in colorectal cancer (see *Section III, 3.3 GNAS and PKA link inflammation to cancer initiation*). Finally, pathogenic mutation of PKA phosphosites is emerging as a mechanism of disease. For instance, Parkinson's disease mutations in *LRRK2*, highlight the specific mutation of PKA phosphosites known to regulate LRRK2 activity (Muda et al., 2014). It is important to synthesize the mutational themes and mechanisms of dysregulation that define the Gas-PKA pathway signalopathies. This is a critical step necessary to connect the genomic and biochemical findings with clinical manifestations and ultimately catalyze the development of new, effective therapies.

III. Human Gas-PKA pathway signalopathies

1. Infectious diseases

1.1 Cholera

Perhaps one of the best examples of Gas-PKA pathway-mediated pathophysiology is the severe diarrhea caused by infection with *Vibrio cholera*, or cholera. Cholera continues to be a global health concern, contributing to hundreds of thousands of deaths each year (Ali et al., 2015). Cholera toxin has a unique ability to ADP-ribosylate Gas at arginine 201. The addition of an ADP-ribose group inhibits the GTPase activity of Gas and renders it constitutively active in a manner similar to the disease associated R201 mutations (discussed in *Section II, 1. Mutations in GNAS*) (Kaper et al., 1995; Landis et al., 1989). Overactivation of Gas by cholera toxin leads to cAMP production and PKA activation in the intestinal epithelium (Figure 8A). In crypt cells, PKA

activity enhances secretion of Cl^- into the intestinal lumen due to direct regulation of the cystic fibrosis transmembrane conductance regulator (CFTR) channel. Under normal physiological conditions, the degree of phosphorylation of four PKA phosphosites controls the degree of CFTR channel opening. Thus overactive PKA in response to cholera leads to maximal channel opening. In villous cells, PKA also functions to decrease Cl^- absorption by inhibiting Na^+/Cl^- co-transporters and Na^+/H^+ exchangers (Goodman and Percy, 2005). Due to osmotic imbalance, water rapidly moves out of cells into the intestinal lumen, overwhelming reabsorption mechanisms and producing severe, watery diarrhea and dehydration that can prove deadly if left untreated (Figure 8A). Interestingly, cystic fibrosis patients are resistant to the effects of cholera toxin due to mutations in the CFTR channel. Notably, the majority of patients harbor the F508del mutation in the regulatory region of CFTR. This mutation causes PKA phosphorylation defects that alter trafficking through the endoplasmic reticulum (ER) and Golgi to the cell surface as well as disrupt the conformational cues induced by PKA phosphorylation that are critical to channel opening (Bharati and Ganguly, 2011; Chin et al., 2017; Goodman and Percy, 2005; Kaper et al., 1995).

2. Endocrine and metabolic diseases

2.1 Carney Complex

Carney Complex is a rare disease that is characterized by multiple neoplasms of both endocrine (commonly adrenal, pituitary, or thyroid glands and gonadal tissues) and non-endocrine tissues (commonly heart, skin, or eye). First described in 1985, only about 750 individuals have been diagnosed worldwide (Correa et al., 2015). Interestingly, 70% of the cases are familial, following autosomal dominant inheritance patterns, with the majority of patients having inactivating mutations in *PRKAR1A* (Bertherat et al., 2009; Kirschner et al., 2000b). Additionally, 35% of sporadic cases are also caused by these same mutations (Kirschner et al., 2000b). In fact, Carney Complex was the first disease to be associated with mutations in the PKA

Figure 8. Gas-PKA pathway signalopathy pathophysiology. A) Pathophysiology of Cholera. Cholera is an intestinal parasite that when consumed via contaminated water, enters the digestive tract. In the intestinal epithelium, Cholera toxin ADP-ribosylates and activates Gas, leading to overactivation of protein kinase A (PKA). PKA directly phosphorylates the cystic fibrosis transmembrane conductance regulator (CFTR) to facilitate channel opening. Efflux of chloride ions disrupts normal ionic gradients and water passes into the intestinal lumen to compensate. Consequently, the clinical manifestations of cholera include watery diarrhea and dehydration. B) Cushing's Syndrome pathophysiology. Adrenocorticotropic hormone (ACTH) is secreted by the pituitary gland in the brain and travels through the bloodstream to the adrenal gland located on top of the kidney. ACTH binds to the melanocortin receptor (MC₂R) on the surface of adrenocortical cells to activate PKA and stimulate cortisol secretion. In Cushing's Syndrome, loss of function mutation in R1 α (or gain of function mutation in C α) lead to persistent PKA activation and excess cortisol secretion. Clinical manifestations of the disease exacerbate the effects of cortisol and include hypertension, hyperglycemia, and obesity. C) Fibrous dysplasia pathophysiology. Fibrous dysplasia is a post-zygotic disease caused by activating mutation in *GNAS*. Persistent activation of PKA in mesenchymal stem cells impairs proper differentiation to adipocyte, chondrocyte, and osteogenic lineages. In particular, accumulation of osteogenic precursors shifts the balance of osteoblasts and osteoclasts to favor bone resorption by osteoclasts. Resulting clinical manifestation of the disease include brittle bone and frequent fracture or deformity.

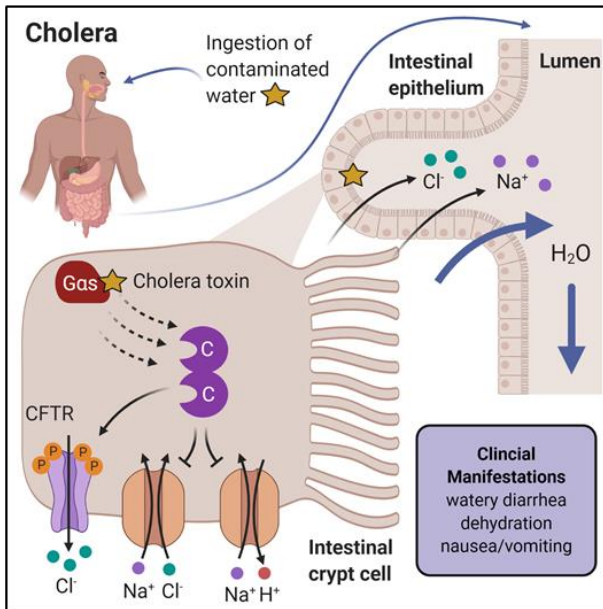
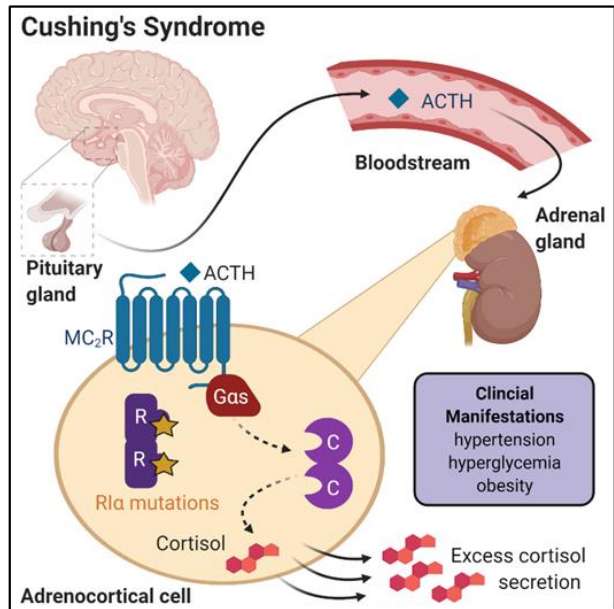
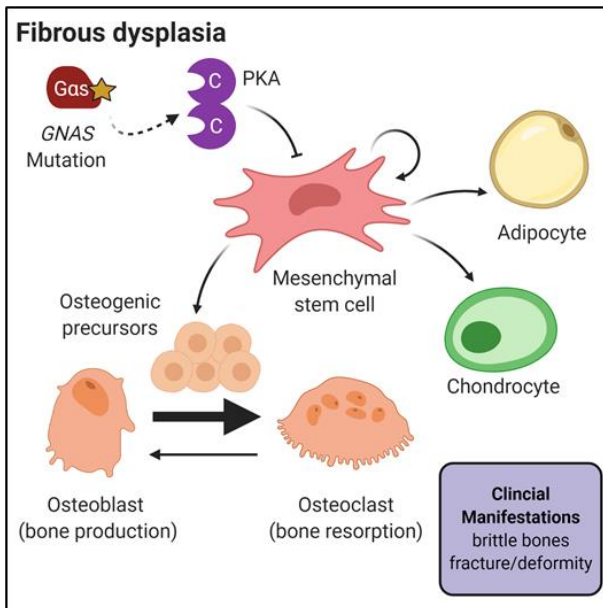
A**B****C**

holoenzyme(Kamilaris et al., 2019). As mentioned previously, the vast majority of mutations are not actually expressed due to NMD, creating *PRKAR1A* haploinsufficiency ultimately resulting in catalytic subunit hyperactivity(Bertherat et al., 2009). Aligned with this concept, a Carney Complex patient with copy number gains in *PRKACB* has also been documented(Forlino et al., 2014).

Carney Complex is a heterogeneous disease with typical onset around age 20, but some patients have even been diagnosed as children(Correa et al., 2015). Interestingly, patients with *PRKAR1A* mutations tend to present at a younger age with specific phenotypes(Bertherat et al., 2009). Most patients present with Cushing's Syndrome (see *Section III, 2.2 Cushing's Syndrome and adrenocortical adenomas*) and endocrine phenotypes. One of the most common physical characteristics, is the presence pigmented skin lesions, like *café-au-lait* spots, caused by the hyperproliferation of melanocytes (also seen in McCune-Albright Syndrome, see *Section III, 2.4 Fibrous dysplasia and McCune-Albright Syndrome*). Another common characteristic is cardiac myxoma, a neoplasm of the heart. Cardiac myxoma represents a major cause of mortality in Carney Complex due to its rapid growth and recurrence resulting in obstruction of blood flow in the heart (see *Section III, 2.3 Cardiac myxoma*)(Wang et al., 2018). Finally, the most common endocrine phenotype is primary pigmented nodular adrenocortical disease (PPNAD), affecting up to 60% of Carney Complex patients. As the name suggests, it manifests as pigmented nodules on the adrenal gland(Bertherat et al., 2009). This results in adrenocorticotrophic hormone (ACTH)-independent Cushing's Syndrome, which is discussed in the next section. Interestingly, PPNAD can occur outside of Carney complex and is not only caused by mutations in *PRKAR1A*, but can also be caused *PDE8B* or *PDE11A* mutations(Bertherat et al., 2009; Kamilaris et al., 2019) (Figure 7A, Table S2). This highlights that overactive PKA is a driver of this disease, regardless of how it is achieved.

Similarly, the physical manifestations of the disease are in line with the importance of PKA signaling to the cell types affected by Carney Complex. In these tissues, normal programs, such as growth and development, and energy metabolism are driven by the hormone-GPCR-Gas-PKA

signal transduction axis (see *Section I, 5. Metabolic regulation* for more information on energy metabolism). Acting through cAMP second messengers, PKA mediates systemic responses to hormones of the pituitary, adrenal gland, thyroid, parathyroid, and hypothalamus as well as more local responses in tissue such as the pancreas, kidney, liver, and gonads(Tilley and Fry, 2015). Of note, individual mutations in their cognate GPCRs can also cause endocrine phenotypes related to Carney Complex or other Gas-PKA pathway signalopathies(Lania et al., 2006). However, when dysregulation of this signaling occurs through loss of R1 α function, it typically results in neoplastic growth and tumorigenesis across these tissues. In fact, as evidence to the importance of PKA in global growth and development, *Prkaca* knockout mice weigh 65% less than control littermates and exhibit a significant growth delay(Skålhegg et al., 2002).

2.2 Cushing's Syndrome and adrenocortical adenomas

Cushing's Syndrome is a rare disease that affects around 2 individuals per million per year across the world(Steffensen et al., 2010). It can present with very broad symptoms, including hypertension, hyperglycemia, obesity, skin changes, mood disorders, and other hormonal changes. While these symptoms can have multiple etiologies, Cushing's Syndrome is specifically characterized by exposure to excess cortisol(Sharma et al., 2015). Cortisol is a hormone that helps control the stress response by regulating blood pressure and blood sugar as well as dampening the immune response. The release of cortisol is regulated by adrenocorticotrophic hormone (ACTH), which is secreted by the pituitary glands at the base of the brain. Once in the bloodstream, ACTH travels to the adrenal gland, located on top of the kidneys, where it binds the melanocortin receptor (MC₂R). MC₂R is a Gas-linked GPCR located on the surface of the adrenocortical cells, which when stimulated activates PKA to trigger cortisol secretion (Figure 8B). Cushing's Syndrome has many etiologies, including overuse of glucocorticoid medication, ACTH-secreting pituitary tumors (termed Cushing's Disease), or cortisol-secreting adrenocortical adenomas(Sharma et al., 2015). Although rare, Cushing's Syndrome can also have genetic

causes that converge on overactivation of the PKA pathway. One of the most common genetic causes of Cushing's Syndrome is *PRKACA* L206R mutation. As mentioned previously, L206R disrupts regulatory subunits contacts, leading to constitutive PKA activity. This mutation, along with loss of function mutations in *PRKAR1A*, underlie ACTH-independent Cushing's Syndrome (Figure 8B). Similarly, germline *PRKACA* copy number gains(Beuschlein et al., 2014; Lodish et al., 2015) and somatic *PRKACB* S54L mutations can also cause cortisol-producing adrenocortical adenomas/hyperplasias and Cushing's Syndrome(Espiard et al., 2018). Somatic mutations in *GNAS* and *PDE8D* have also been identified(Espiard et al., 2018). In general, patients with PKA gene mutations have earlier onset of disease with more co-morbidities. There is some evidence, at least for germline *PRKACA* amplifications, that this is a dose-dependent effect, with patients harboring *PRKACA* triplication having the most severe symptoms and earliest onset(Lodish et al., 2015). Interesting, patients with *GNAS* and *PRKACA* mutations have smaller tumor sizes, which is a sign that the tumor is capable of efficient cortisol production and secretion(Goh et al., 2014). This finding is also in line with the role of cAMP in controlling regulated exocytosis which contributes to hormone secretion in endocrine cells. For instance, in the pituitary, cAMP increases the size of secretory granules(Seino and Shibasaki, 2005) and in the adrenal gland, basal PKA signaling is required to maintain the vesicle pools that are primed and ready to be exocytosed(Nagy et al., 2004). In general, increase in intracellular Ca^{2+} is the main driver of exocytosis, but cAMP can also modulate the response at several different levels through mechanisms involving both PKA and EPAC.

While Cushing's Syndrome is the most prominent diagnosis, primary macronodular adrenal hyperplasia (PMAH) is a related disorder which reflects a spectrum of disease ranging from subclinical hypercortisolism all the way to overt Cushing's Syndrome. Of note, it can also be part of the manifestations of McCune-Albright Syndrome (see *Section III, 2.4 Fibrous dysplasia and McCune-Albright Syndrome*)(De Venanzi et al., 2014). It is characterized by large functional nodules on the adrenal gland that alter cortisol secretion. Although rare, PMAH can be caused by

activating mutations in *MC2R* (encoding MC₂R)(Hiroi et al., 1998; Swords et al., 2004) or *GNAS*(Fragoso et al., 2003; Hsiao et al., 2009).

2.3 Cardiac myxoma

Cardiac myxomas (CMs) can occur in the context of Carney Complex and this accounts for about 7% of all CM cases(Milunsky et al., 1998). The vast majority of the Carney Complex patients have loss of function mutations in *PRKAR1A* (70%)(Bertherat et al., 2009; Wang et al., 2018). For these patients, CMs typically present earlier in life (with frequent reoccurrence) and can affect any chamber of the heart with multiple lesions. Conversely, isolated sporadic CMs typically occur as a single lesion in middle-aged women (mean age 51 years) and preferentially in the left atria(Carney, 1985; Reynen, 1995; Stratakis et al., 2001). Interestingly, it is estimated that anywhere from 31%(Maleszewski et al., 2014) to 64%(He et al., 2017) of isolated sporadic CMs are also caused by loss of function mutations in *PRKAR1A*. While the vast majority CMs are sporadic, there are also a few reports of familial CMs not associated with Carney Complex. Typically, these familial mutations follow autosomal dominant inheritance. For instance, in one family both the father (44 years of age) and daughter (20 years of age) developed CM due to the V164D frameshift deletion (c.491_492delTG) in *PRKAR1A*. The woman's uncle and brother did not harbor the mutation and had no signs of CM to date(Ma et al., 2019). CMs are the most common primary tumor in the heart and although they are benign, they can cause significant morbidity and mortality because of their location(Reynen, 1995). The mechanism of tumorigenesis for CM is not fully understood, but it is thought that mesenchymal stem cells (MSCs) from the endocardium and epicardium are the cell of origin(Di Vito et al., 2015). Effects on this MSC population may also account for *GNAS* mutations found in intramuscular and cellular myxomas (>90% *GNAS* mutants)(Sunitsch et al., 2018). Of note, MSCs are also the cell of origin for Fibrous Dysplasia which is discussed in the next section.

2.4 Fibrous dysplasia and McCune-Albright Syndrome

Fibrous dysplasia (FD) is a rare skeletal disorder that is characterized by painful and brittle bones which are prone to fracture and deformity. The clinical presentations can be very heterogeneous, affecting one bone (monostotic) or multiple bones (polyostotic) with variable severity. FD can also present with additional manifestation of *café-au-lait* spots or endocrine hyperfunction, which is termed McCune-Albright Syndrome (MAS)(Feller et al., 2009; Riminucci et al., 2010). Additionally, if FD presents with intramuscular myxomas, tumors of musculoskeletal soft tissue, it is termed Mazabraud Syndrome. FD/MAS is caused by post-zygotic somatic activating mutations in *GNAS* (*GNAS* R201C/H) (Figure 8C), thus the disease is not inherited. The heterogeneity of FD/MAS results from somatic mosaicism, wherein some cells inherit the defect, while others do not. The tissues involved in FD/MAS arise from all the three embryonic germ layers (ectoderm, endoderm, mesoderm), suggesting that in most cases the mutation may be acquired prior to gastrulation, before cell lineage decisions are made(Feller et al., 2009; Riminucci et al., 2006).

Recent studies by our groups and others have demonstrated that expression of *GNAS* activating mutations in mesenchymal/skeletal stem cells is necessary and sufficient to drive FD development in mouse models(Zhao et al., 2018). Interestingly, germline expression of the FD mutation is embryonic lethal(Khan et al., 2018), but when expression is induced during embryogenesis or postnatally, FD lesions develop rapidly(Zhao et al., 2018). The severity of the disease, however, is not linked to stage of development in which the mutation is acquired, but rather the degree to which mutated cells contribute to critical functions within the tissues(Feller et al., 2009; Riminucci et al., 2006). For instance, patients with a higher ratio of mutated cells to normal cells in the osteogenic progenitor pool will develop more severe FD, while patients with a higher ratio of normal cells to mutant cells will display milder phenotypes. In fact, isolation of bone marrow stroma progenitors from FD patients revealed that the stroma is a mosaic of mutant and normal cells. Mosaic stromal marrow engrafts into immunocompromised mice while purified

mutant marrow fails to engraft(Bianco et al., 1998). Therefore, it has been proposed that there is a “critical mass” of mutated cells that are necessary to drive symptomatic disease(Feller et al., 2009; Riminucci et al., 2006).

Under normal physiologic conditions, bone is constantly being remodeled, which is a balance between bone production by osteoblasts and bone resorption by osteoclasts. Overactivation of G α s signaling through PKA induces proliferation of osteogenic precursors, but impairs proper differentiation of osteoblasts and mineralization while enhancing osteoclast differentiation(Riminucci et al., 1997; Zhao et al., 2018) (Figure 8C). Ultimately, this shifts the balance towards bone resorption which is a histological marker of FD in patients.

2.5 Acromegaly, gigantism, and pituitary tumors

Acromegaly and gigantism are rare diseases characterized by overproduction of growth hormone (GH). GH is normally secreted by the pituitary gland into the bloodstream where it travels to the liver to stimulate insulin-like growth factor-1 (IGF-1) production and growth of bones and body tissues. Gigantism occurs early in childhood before growth plate fusion, resulting in dramatic vertical growth, while acromegaly occurs in adulthood and is characterized by growth and swelling of many body tissues, including hands, feet, nose, lips, jaw, and brow(Hannah-Shmouni et al., 2016). In most cases, acromegaly and gigantism are caused by somatotropinoma or GH-secreting pituitary tumors. The majority of GH-secreting pituitary tumors occur sporadically, but there are a few examples of familial cases. The most common sporadic alteration in acromegaly is *GNAS* activating mutations (40-60%)(Freda et al., 2007; Hage et al., 2018). Typically, these patients have smaller tumors, but very high GH secretion, highlighting again the physiologic role of the cAMP in secretion. Of note, no mutations have been identified in the *PRKACA* or *PRKACB*(Larkin et al., 2014) and *GNAS* mutations specifically enrich in GH-secreting pituitary tumors over other subtypes of pituitary tumors(Bi et al., 2017). In about 10% of gigantism, patients have very early-onset disease (before the age of 4), known as X-linked acrogigantism (XLAG). In

addition to overproduction of GH, XLAG patients also overproduce the hormone prolactin (PRL). XLAG is caused by duplications in *GPR101*, an orphan GPCR on the X chromosome. XLAG predominates in females, but some males also acquire sporadic mutations (Gadelha et al., 2017; Iacovazzo and Korbonits, 2016). Additionally, there have been two independent families that display *GPR101* duplications. *GPR101* is predicted to couple to G α s and has been shown to stimulate cAMP production *in vitro*, however there is some evidence it could couple to G α i as well (Bates et al., 2006; Iacovazzo and Korbonits, 2016; Martin et al., 2015).

Acromegaly and gigantism are also associated with Carney Complex and McCune-Albright Syndrome, but in these cases it is generally caused by hyperplasia of the somatotrophs, GH-secreting cells in the pituitary, instead of overt tumors. In Carney Complex, most patients have *PRKAR1A* loss of function mutations, leading to PKA activation and GH and PRL excess, but only about 10% of patients actually present with acromegaly. For McCune-Albright Syndrome, a smaller percentage of patients have pituitary involvement, but of those, 36% develop gigantism, while the other 64% develop acromegaly (Boikos and Stratakis, 2007; Gadelha et al., 2017).

2.6 Hyperthyroidism

Hyperthyroidism is a disease where the thyroid gland is overactive, producing too much of the hormones that control metabolism, triiodothyronine (T3) and tetraiodothyronine (T4). This leads to increased appetite and unintentional weight loss, rapid and irregular heartbeat, restlessness, and potentially goiter (enlargement of the thyroid gland) (De Leo et al., 2016). Hyperthyroidism can have many causes, but as previously mentioned, it can be a component of Carney Complex and McCune-Albright Syndrome. Whether or not patients present as part of a broader syndrome, these non-autoimmune hyperthyroidisms can be caused by activating mutations in the thyroid-stimulating hormone receptor (TSHR, encoded by *TSHR*) or *GNAS*. As a GPCR, TSHR couples to G α s to control secretion of T3 and T4, but activating mutations in this pathway can cause thyroid adenomas that autonomously secrete hormones (Hébrant et al., 2011;

Lacka and Maciejewski, 2015). Of these thyroid adenomas, 5-10% are caused by *GNAS* mutations and 70-80% are caused by *TSHR* mutations(Nishihara et al., 2009; Palos-Paz et al., 2008). A recent report suggested that for hot thyroid nodules (nodules that preferential take up radioactive iodine, generally with excess thyroid-stimulating hormone (TSH) secretion), *GNAS* and *TSHR* are the only driver mutations, with a clear preference for *TSHR* mutations(Stephenson et al., 2020). Over 30 different mutations in *TSHR* have been documented. Some mutations have been identified in adenomas as well as sporadic and familial cases, while others have preference for specific subsets(Hébrant et al., 2011). The reason for this preference is a balance between mutation expression and strength of activation. Strong clonal mutations are likely to cause adenomas and sporadic hyperthyroidism, while weaker germline mutations expressed in all cells are likely to cause familial cases. Although there is no defined syndrome, it is probable that particularly strong germline *TSHR* mutations are embryonic lethal since thyroid hormones are critical to fetal development(Lacka and Maciejewski, 2015).

2.7 Inactivating PTH/PTHrP signaling Disorder (iPPSD)

Unlike the other diseases discussed so far, inactivating PTH/PTHrP signaling disorder (iPPSD), represents a heterogeneous group of disorders that is characterized by inactivating defects in the *G α s*-PKA signaling pathway. Clinical features of this disease are diverse and overlapping among subtypes. Common features include, skeletal deformities (bracydactyly, short stature), obesity, cognitive impairment, and hormone insensitivity leading to improper mineral metabolism, and delayed reproductive development, among other manifestations(Mantovani and Elli, 2018; 2019). The current iPPSD nomenclature encompasses diseases such as Blomstrand chondrodysplasia/Eiken syndrome, pseudohypoparathyroidism (PHP), acrodysostosis (ACRDYS), Albright's hereditary osteodystrophy (AHO), and progressive osseous heteroplasia (POH), but the specific distinctions are beyond the scope of this review(Mantovani and Elli, 2019). Here we will focus on the molecular underpinnings of the iPPSD subtypes.

The clinical features of iPPSD highlight the physiologic roles of parathyroid hormone (PTH) signaling in a wide variety of developmental and homeostatic mechanisms. PTH is secreted from the parathyroid glands located in the neck to regulate calcium and phosphate homeostasis by signaling through the parathyroid hormone receptor (PTHR). PTHR is a G α -coupled GPCR that is expressed at particularly high levels in the bone and kidney. Not surprisingly, inactivating mutations in PTHR (*PTH1R*) cause iPPSD1 with predominately skeletal defects. G α itself is also subject to heterozygous loss of function mutations or more commonly genomic imprinting that reduces G α mRNA and protein levels by around 50% (iPPSD2/3)(Mantovani and Elli, 2019; Turan and Bastepe, 2015). Clinical phenotypes, particularly heterotopic ossification, are recapitulated in mice with *Gnas* knockout in mesenchymal progenitor cells(Regard et al., 2013). *GNAS* is also subject to tissue-specific maternal imprinting or loss of paternally-imprinted methylation patterns in particular regions on the *GNAS* locus. Patients with loss of function in G α display variable resistance to hormones, including PTH, TSH, gonadotropin, and GHRH, which determine their clinical manifestations(Mantovani and Elli, 2018; 2019). For instance, all patients of these subtypes display bone and adipose phenotypes due to biallelic expression of G α in these tissues, while individuals with maternally inherited loss of function will present with additional cognitive and endocrine phenotype due to paternal imprinting of G α in these tissues(Long et al., 2007; Mantovani et al., 2004; Mouallem et al., 2008; Turan and Bastepe, 2015). In line with the importance of the G α -PKA signaling pathway, mutations in R1 α , PDE4D, and PDE3A characterize the remainder of the molecularly defined iPPSD subtypes (iPPSD4/5/6)(Mantovani and Elli, 2019). Of particular note, mutations in PDE3A further highlight the importance of cAMP in driving the pathophysiology of iPPSD. As mentioned previously, PDE3 family members can hydrolyze both cAMP and cGMP. Interestingly, mutations in PDE3A have been shown to enhance the cAMP hydrolyzing activity without altering enzymatic activity towards cGMP, ultimately resulting in reduced cellular cAMP levels(Ercu et al., 2020; Maass et al., 2015).

3. Neoplasms and carcinomas

Thus far we have highlighted the role of PKA signaling in neoplasms of the adrenal, pituitary, thyroid, gonads, and even heart due to both germline or somatic mutations in the pathway, all members of the broad and overlapping endocrine and metabolic Gas-PKA pathway signalopathies. Many of these neoplasms are monogenetic and inherently accompanied by endocrine hyperactivity, a process in which it is evident overactive Gas-PKA signaling is the driver of pathophysiology. In the context of cancer, however, disease is rarely the result of a single mutation, but rather a complex polygenetic network subject to the biology of diverse tissues and other modulatory inputs like inflammation and immune evasion. With the precision medicine revolution and rapid advances in cancer genomics, we can finally begin to appreciate a broader role of Gas-PKA in cancer as both an oncogenic driver and tumor suppressor. By leveraging our knowledge of mutational themes and Gas-PKA-mediated pathophysiology, we can begin to understand many cancers as emerging Gas-PKA pathway signalopathies.

3.1 GNAS-PKA as oncogenes: beyond endocrine tumors

A real shock to the field came with the discovery of a PKA fusion protein that drives a rare form of liver cancer (<1% of cases), known as fibrolamellar hepatocellular carcinoma (FL-HCC)(Honeyman et al., 2014). Affecting children and young adults with no underlying pathology, FL-HCC could not be more different from the majority of liver cancers, which affect adults with liver damage commonly due to viral infection or alcoholism. As mentioned previously, FL-HCC patients were found to express an in-frame fusion of DNAJB1 with PKA C α (*DNAJB1-PRKACA*) that resulted in increased PKA activity due to relative overexpression of the catalytic subunit(Riggle et al., 2016), but importantly overexpression of *PRKACA* does not completely recapitulate the oncogenicity of the fusion protein(Kastenhuber et al., 2017) (see *Section II, 4. Fusion proteins: an emerging mutational theme*) (Figure 6A). To date across multiple studies, *DNAJB1-PRKACA* has been identified in nearly 80% of FL-HCC patients(Cornella et al., 2015).

Figure 9. Protein kinase A pathway mutations in cancer. A) Frequency of specific pathway gene mutation across several tumor and cancer types. Heatmap is colored by mutation frequency (0 to >50%) with darker purple representing higher mutational frequency. All gene mutations from whole genome sequencing datasets are included (COSMIC database)(Tate et al., 2018). B) Frequency of pathway mutation grouped by gene family across tumor and cancer types. A sample is considered to have a pathway mutation if it harbors at least one mutation in a family gene member.

A Cancer mutations

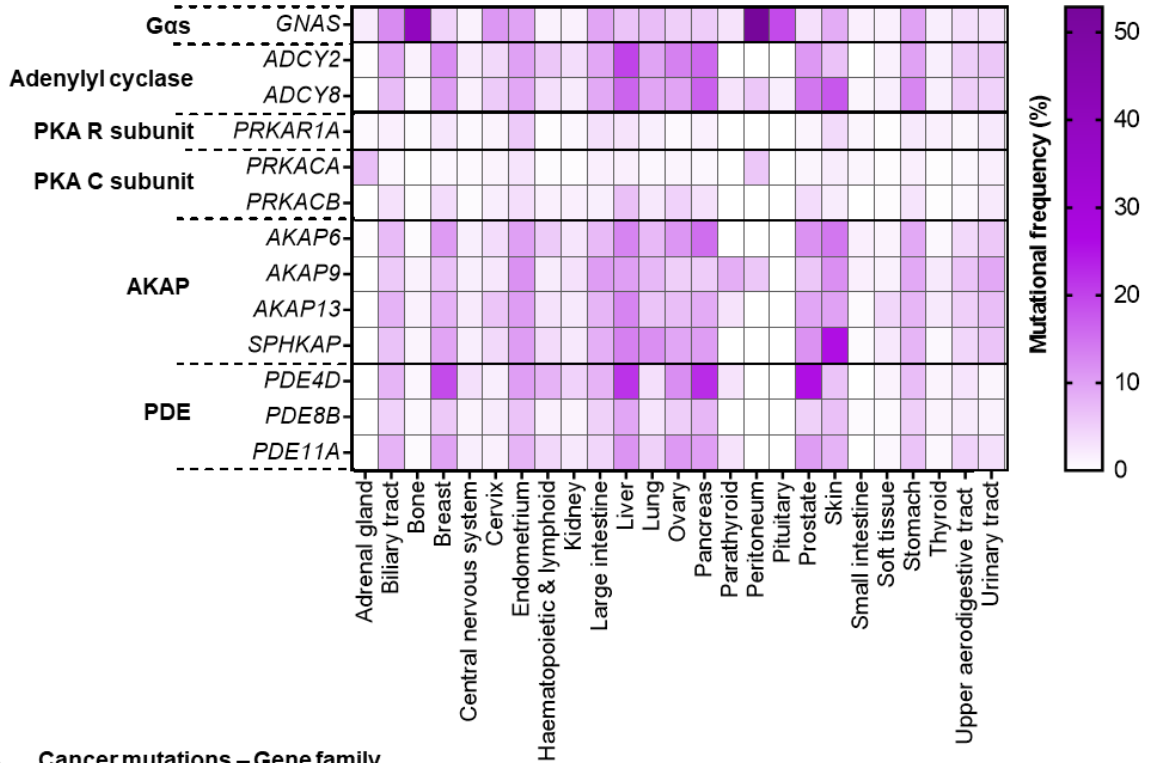

B Cancer mutations – Gene family

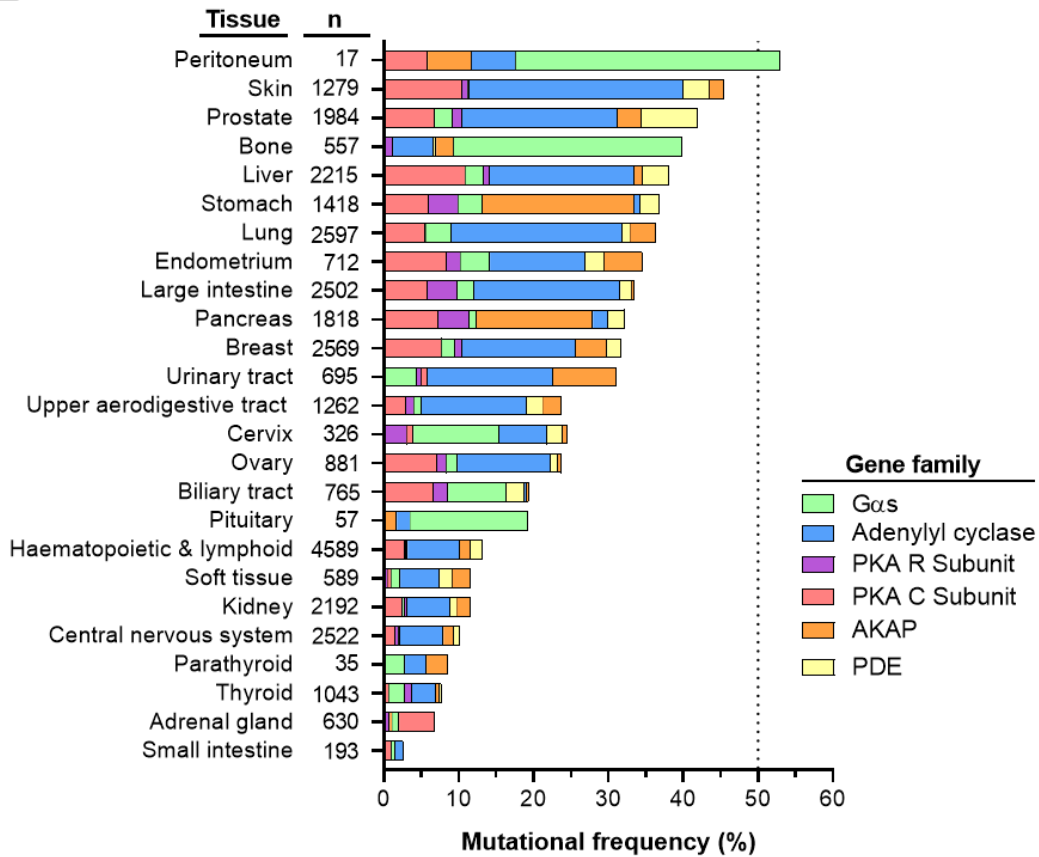

Of note, several FL-HCC patients lacking the DNAJB1-PRKACA fusion protein, but with a history of Carney Complex and other tumors, exhibited a complete loss of R1 α protein instead (Graham et al., 2018). Recent studies have pointed to an even broader role of PKA fusion proteins, including additional fusions with PRKACB and ATP1B1, suggesting that they may also be driver oncogenes in extrahepatic cholangiocarcinoma, intraductal oncocytic papillary neoplasms (IOPNs), and intraductal papillary mucinous neoplasms (IPMNs) of the pancreas and bile duct (Nakamura et al., 2015; Singhi et al., 2020; Vyas et al., 2020) (Figure 6A).

While *DNAJB1-PRKACA* in FL-HCC clearly establishes PKA as an oncogenic driver, broader analysis of cancer genomes by our group revealed that *GNAS* is the most highly mutated G protein, harboring mutations in over 4% of all sequenced tumors to date, with the majority representing hotspot mutations (Arang and Gutkind, 2020; O'Hayre et al., 2013; Wu et al., 2019). Surprisingly, we and others have noted that among *GNAS* mutated cancers, there is a clear enrichment of gastrointestinal (GI) cancers, including colorectal adenocarcinoma (4-10%), stomach adenocarcinoma (6-10%), and pancreatic adenocarcinoma (5-12%); a finding which extends to GPCRs and other G protein subunits (Arang and Gutkind, 2020; Innamorati et al., 2018; O'Hayre et al., 2013; Wu et al., 2019). *GNAS* and PKA also seem to be particularly important to neuroendocrine cancers of the pancreas, prostate, liver, and lung (Boora et al., 2015; Coles et al., 2020; Deeble et al., 2007; Innamorati et al., 2018; Kasthuber et al., 2017). Expanding on these observations, we find that *GNAS* mutation frequency is even more significant in less studied cancers such as those of the bone (40%) and the peritoneum (53%) (Figure 9A, Table S5). While *GNAS* mutation is recognized for its importance in cancer and is routinely included in clinical sequencing panels, such as FoundationOne (<https://www.foundationmedicine.com/>), analysis of the broader pathway reveals that mutations occur at every node. There are particularly good examples of each, such as *ADCY2* mutations in liver (20%), *PDE4D* mutations in prostate (25%), and *SPHKAP* in skin (26%) (Figure 9A, Table S5). Given that there are many genes representing each node of the pathway, when we consider the mutation frequency of each gene family, it

becomes clear that some gene families are preferentially mutated in certain tissues, for instance *GNAS* mutations predominate in hormone-sensitive tissues (Figure 9B, Table S5). Somewhat strikingly we find that adenylyl cyclase mutations constitute the bulk of the mutations across many tissue types. Intriguingly, AKAPs are mainly mutated in the stomach and pancreas, while PKA catalytic subunits have a consistent low level of mutation across most tissues (Figure 9B, Table S5). Of important note, most patient samples harbor only one or two pathway mutations (57%) with the majority of those (41%) being single pathway mutations (Table S5). As we discussed previously, there is limited knowledge on the functional importance of mutations within these other nodes of the pathway (see *Section II, 5. Expanding the mutational themes*), but given the emergence of genomic medicine and the success of targeted therapies, the role of the Gas-PKA pathway in cancer certainly warrants further study. For the remainder of this review, we will highlight examples of the clinical and biological function of the Gas-PKA pathway in cancer.

3.2 Mucin production drives clinical phenotypes

One of the most striking and clinically relevant features of *GNAS* mutant cancers is their high level of mucin production across several tissue types (lung, stomach, bile duct, pancreas, appendix, colorectum, and gonads)(Innamorati et al., 2018). Mucins are large glycoproteins, either secreted or membrane-bound, with important physiologic and homeostatic roles. In the intestine, mucin provides the first-line of defense against microbes and is critical to preserving epithelial barrier integrity. Mucins also have important structural roles to help physically maintain the microvilli architecture that is so important to intestinal function(Pelaseyed and Hansson, 2020). Consequently, the dysregulation of mucin can have profound impacts on disease. For instance, *Muc2* knockout mice have defects in goblet cell differentiation. This results in increased epithelial cell proliferation and migration, coupled with decreased apoptosis and lack of acidic mucin production. Ultimately these *Muc2* knockout mice spontaneously develop tumors in the small and large intestine that progress to invasive carcinoma(Velcich et al., 2002). Interestingly,

the G α s-PKA pathway is known to directly regulate MUC2 expression through the G protein coupled E-type prostanoid receptor 4 (EP4) in the intestine. PKA-mediated activation of CREB triggers binding to the cAMP-responsive element (CRE) in the *MUC2* promoter and transcriptional upregulation(Dilly et al., 2017; Nishikawa et al., 2013). In pancreatic ductal cells, *GNAS* mutation is known to dramatically increase the expression of another mucin, *MUC5AC*. *MUC5AC* is one of the predominant mucins overexpressed in intraductal papillary mucinous neoplasms of the pancreas (IPMNs) which commonly harbor *GNAS* hotspot mutations (discussed below)(Ideno et al., 2013; Komatsu et al., 2014). Transcriptional upregulation of mucin production is also augmented by the role of cAMP and PKA in vesicular transport. PKA is involved in constitutive transport of vesicles through the trans-Golgi network to the cell surface(Muñiz et al., 1996). Specifically, AKAPs anchor PKA to the cytoplasmic surface of the ER (AKAP1) and Golgi (AKAP1/9) where it can be activated in response to extracellular stimulation(Huang et al., 1999; Ma and Taylor, 2008; Mavillard et al., 2010; Rios et al., 1992).

At a molecular level, mucin overexpression in cancer has been implicated in dysregulation of cell polarity and disruption of proper cell-cell contacts. Further, mucin can facilitate aberrant oncogenic signaling, such as β -catenin activation, and receptor tyrosine kinase oligomerization and activation(Kaur et al., 2013; Pelaseyed and Hansson, 2020; Pothuraju et al., 2020). Mucin is also thought to play an important role in modulating the tumor microenvironment, serving as a bridge to nutrient rich stroma through neoangiogenesis as well as by providing immunosuppressive mechanisms to evade immune surveillance. In addition to biological effects on the tumor microenvironment, mucin can also serve as a physical barrier, sequestering local growth factors and protecting neoplastic cells from cytotoxic agents(Hollingsworth and Swanson, 2004; Kaur et al., 2013). Consequently, mucinous adenocarcinoma (in which >50% of the tumor mass is mucin) and tumors with a mucinous component (<50% of tumor mass is mucin) are implicated with poor prognosis and chemoresistance across many tissue types(Asare et al., 2016; Kajiyama et al., 2014; Lee et al., 2013; Schiavone et al., 2011; Xie et al., 2018). Of note,

pseudomyxoma peritonei (PMP) is one of the most devastating examples of mucin dictating clinical outcomes, where the 5-year survival rate of high-grade disease is only 23%(Nummela et al., 2015). PMP is an extremely rare subtype of mucinous adenocarcinoma (typically originating from the appendix) where the peritoneal cavity is colonized by mucin-secreting neoplastic cells. The excess mucin (>90% of tumor volume, dominated by MUC2 and a lesser extent MUC5AC)(O'Connell et al., 2002) overtakes the peritoneum, obstructing normal intestinal function, and ultimately killing the patient. *GNAS* hotspot mutations are found in 63% of all PMPs including both low and high-grade disease (56% and 70%, respectively). Currently, the only therapeutic options for these patients are reductive surgery and intraperitoneal chemotherapy, which have significant treatment associated morbidity. Thus, targeting the Gas-PKA pathway as a means to limit mucin production has been proposed for PMP patients(Nummela et al., 2015). Interestingly, in recurrent PMP, patients with *GNAS* mutations have poorer outcomes following chemotherapy, but it is uncertain if this is due to the biology of *GNAS* mutants or if *GNAS* is a biomarker of therapeutic resistance (discussed in *Section III, 3.5 Gas-PKA induced therapeutic resistance in cancer*)(Pietrantonio et al., 2016).

When considering the prevalence of *GNAS* mutations in PMP, among other cancer subtypes, another trend that becomes rapidly apparent is a co-occurrence with *KRAS* mutations (63-72% of *GNAS* mutant PMPs also harbor *KRAS* mutations)(Ang et al., 2018; Nummela et al., 2015). Furthermore, in mucinous neoplasms of the appendix, 69% of patients with *GNAS* mutations actually harbor *GNAS* and *KRAS* co-mutations. Nearly all of these patients had low-grade histology(Alakus et al., 2014). Another study corroborated this, finding that 50% of patients with low-grade appendiceal mucinous neoplasm (LAMN), were positive for both *GNAS* and *KRAS* mutations(Nishikawa et al., 2013). Interestingly, 38-43% of patients with intraductal papillary mucinous neoplasms of the pancreas (IPMNs), which are analogous low-grade lesions of the pancreas, harbor both *GNAS* and *KRAS* mutations(Amato et al., 2014; Molin et al., 2013). Furthermore, 58% of villous adenocarcinomas of the colorectum, which are characterized by non-

invasive tissue architecture (similar to LAMN and IPMN) and profound mucin production, are also *GNAS* and *KRAS* co-mutants(Yamada et al., 2012). Together these co-occurrence patterns highlight that *GNAS* and *KRAS* mutation give rise to unique biology in neoplastic diseases that cannot be achieved by either gene alone.

3.3 *GNAS* and *PKA* link inflammation to cancer initiation

Consistent with clinical evidence that *GNAS* mutations are predominantly found in benign, non-invasive lesions, mouse models reveal that *GNAS* mutation alone is insufficient to induce epithelial tumorigenesis(Patra et al., 2018; Wilson et al., 2010). Our team showed that in the context of *KRAS* mutations in the pancreas, *GNAS* drives lesions toward the cystic lineage; together these co-mutants form well differentiated, mucinous cysts that resemble IPMNs, instead of non-cystic pancreatic intraepithelial neoplasias (PanINs). Somewhat counterintuitively, *GNAS* R201C expression does not accelerate *KRAS*-driven progression to pancreatic adenocarcinoma (PDAC). Instead, inactivation of tumor suppressors, like *TP53*, *CDKN2A*, or *SMAD4*, are needed to facilitate efficient progression to PDAC(Ideno et al., 2018; Patra et al., 2018). Interestingly, in the context of PDAC, *GNAS* R201C expression through activation of *PKA* actually attenuates aggressiveness and invasiveness due to epithelial differentiation(Ideno et al., 2018; Pattabiraman et al., 2016). This is supported by clinical evidence that *GNAS* mutant patients have a better overall survival in appendix cancer(Ang et al., 2018). However, in small cell lung cancer (SCLC), a neuroendocrine disease, *GNAS* and *PKA* activity is critical to cancer stem cell maintenance and increases rate of initiation and progression(Coles et al., 2020). This suggests that *GNAS* and *PKA* can play disparate roles within the various stages from neoplastic initiation to carcinogenic progression. Analysis of colorectal tissues on this spectrum from adenoma to carcinoma, revealed that the frequency of *GNAS* mutation drops with progression. For instance, adenomas had the highest frequency of mutation followed by carcinomas with residual benign adenoma, carcinomas with adenoma and regions of invasion, and finally no mutants were detected in pure

carcinomas(Zauber et al., 2016). This suggests that in epithelial tissues, *GNAS* is most important in early initiation events. Indeed, several studies have highlighted that *GNAS* mutation can accelerate tumorigenesis(Coles et al., 2020; Ideno et al., 2018; Patra et al., 2018; Wilson et al., 2010). Given that tumors are heterogeneous, *GNAS* may confer a selective advantage initially in which context additional mutational insults, like *KRAS* and subsequently *TP53*, can drive malignant growth ultimately independent of *GNAS* mutation. To this end, sequencing of normal human colon crypts unsurprisingly show that *KRAS* and *TP53* mutations are rare, suggesting that they are more important in intermediate and late events. However, re-analysis of available data highlights 55% of normal crypts harbored *GNAS* mutations (5 of 9 subjects), supporting the notion that *GNAS* may be important in neoplastic initiation and tumorigenesis(Lee-Six et al., 2019).

This idea of *GNAS* mutations participating in neoplastic initiation tracks well given the established “Vogelgram” of colorectal cancer (CRC) mutation accumulation. In the original model, *KRAS* mutations participated in intermediate events, facilitating the progression of adenomas, while *TP53* loss served as the final barrier to carcinogenesis(Fearon and Vogelstein, 1990). As we have gained more understanding of the molecular events involved in carcinogenesis, COX-2-mediated inflammation has been defined as one of the earliest events in initiation(Markowitz and Bertagnolli, 2009). COX-2 is not expressed under normal conditions, but is rapidly upregulated in response to stress and inflammatory stimuli. Naturally, COX-2 has become a prominent biomarker in colorectal cancer and many others, including lung(Hida et al., 1998), pancreas(Tucker et al., 1999), breast(Ristimäki et al., 2002), liver(Shiota et al., 1999), esophagus(Zimmermann et al., 1999), cervix(Ryu et al., 2000), and skin cancer(Buckman et al., 1998). COX-2 is the inducible form of the cyclooxygenase (COX) enzymes which converts arachidonic acid to lipid signaling molecules, including prostaglandins and thromboxanes. These inflammatory mediators are ligands for a number GPCRs in the prostanoid family(Hata and Breyer, 2004). Most notably, prostaglandin E2 (PGE₂) is the ligand for two Gas-coupled GPCRs, E-type prostanoid receptors 2 and 4 (EP2 and EP4, encoded by the *PTGER2* and *PTGER4* genes, respectively). PGE₂ has

been shown to increase proliferation in colon cancer cells and mediate activation of β -catenin (through Gas) and other mitogenic signaling molecules, like phosphoinositide 3-kinase (PI3K) and Akt (through $G\beta\gamma$ effects)(Castellone et al., 2005).

Frequent and early genomic alteration in the adenomatous polyposis coli gene (APC) are often concurrent with COX-2 overexpression in early initiation events of CRC(Fearon and Vogelstein, 1990; Markowitz and Bertagnolli, 2009), thus highlighting the interplay between their regulated pathways. APC acts a major tumor suppressor in CRC, inhibiting the Wnt- β -catenin signaling route(Kolligs et al., 2002). The Wnt pathway is a major determinant of cell fate decisions, helping to promote stem cell maintenance and tissue renewal from embryogenesis to adulthood. Consequently, these normal programs are frequently co-opted by disease. Wnt signaling controls β -catenin, a coactivator that drives transcription through binding of nuclear transcription factors (i.e. TCF). When the pathway is inactive, β -catenin is sequestered in the cytoplasm by a protein complex termed the destruction complex and ultimately targeted for degradation (Figure 10A). This destruction complex consists of key molecules like glycogen synthase kinase 3 (GSK3), casein kinase 1 α (CK1 α), Axin and APC. CK1 α and GSK3 provide the phosphorylation signals that target β -catenin for ubiquitination and degradation. Canonically, the pathway becomes activated by extracellular Wnts or changes in adherens junctions(Angers and Moon, 2009; Valenta et al., 2012). However, the Gas-PKA pathway can modulate β -catenin activity at several levels (Figure 10A). When activated by receptors, Gas has been shown bind to Axin, leading to the stabilization and activation of β -catenin(Castellone et al., 2005). Many components of the destruction complex are also phosphorylated by PKA. The predominant mechanisms highlight the ability of PKA to phosphorylate and inhibit GSK3, releasing β -catenin to enter the nucleus(Fang et al., 2000). This, coupled with direct PKA phosphorylation of β -catenin to inhibit ubiquitination and degradation, helps drive β -catenin-mediated transcription(Hino et al., 2005). These mechanisms have important biological consequences, including stem cell maintenance and tissue regeneration and repair(Goessling et al., 2009; Wang et al., 2016). Cross-talk with the Gas-

Figure 10. Aberrant protein kinase A pathway activity leads to dysregulation of signaling and transcriptional programs. A) Wnt and PKA activity drive β -catenin-mediated gene transcription. Canonically, Wnt binds to Frizzled receptors and co-receptors like LRP6 on the surface of the cell to inhibit the activity of the destruction complex. Destruction complex members include APC, GSK3, CK1 α , and Axin. Inhibition of this complex releases β -catenin to drive target gene transcription through the transcription factor TCF. Production of prostaglandin E₂ (PGE₂) through cyclooxygenase 2 (COX-2) leads to activation of Gas-coupled G protein coupled receptors (GPCRs), EP2 and EP4. Activation of Gas leads to direct phosphorylation and inhibition of GSK3 as well as stabilizing phosphorylation of β -catenin. These effects coupled with the direct binding of Gas to Axin lead to accumulation of β -catenin and activation of target gene transcription. B) PKA inhibits Hippo pathway and YAP/TEAD-mediated transcription. The Hippo pathway is regulated by a kinase cascade whereby the upstream kinase MST phosphorylates and activates LATS kinase. Phosphorylation of YAP by LATS inactivates YAP through cytoplasmic sequestration and degradation. PKA-mediated phosphorylation of LATS, among other mechanisms, also inhibit YAP activity and consequently block target gene transcription through TEAD. C) PKA regulates Hedgehog (HH) signaling in the cilium to inhibit GLI transcriptional activity. When HH ligand is present, it binds to and inhibits the receptor Patched (PTCH1), allowing the Gai-like G protein coupled receptor (GPCR), Smoothed (SMO) to traffic to the ciliary membrane. SMO inhibits cAMP production and PKA activity, allowing GLI-mediated transcription to proceed. When HH ligand is absent, PTCH1 constitutively inhibits SMO and allows the Gas-coupled GPCR, GPR161, to traffic to the ciliary membrane. When present at the membrane, GPR161 stimulates cAMP production and PKA activity. PKA in turn phosphorylates and inhibits GLI, eventually leading to its degradation.

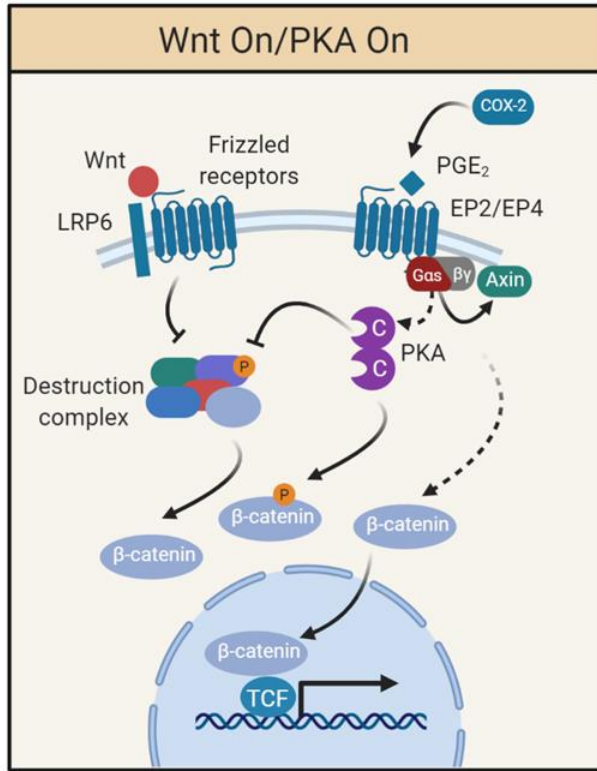
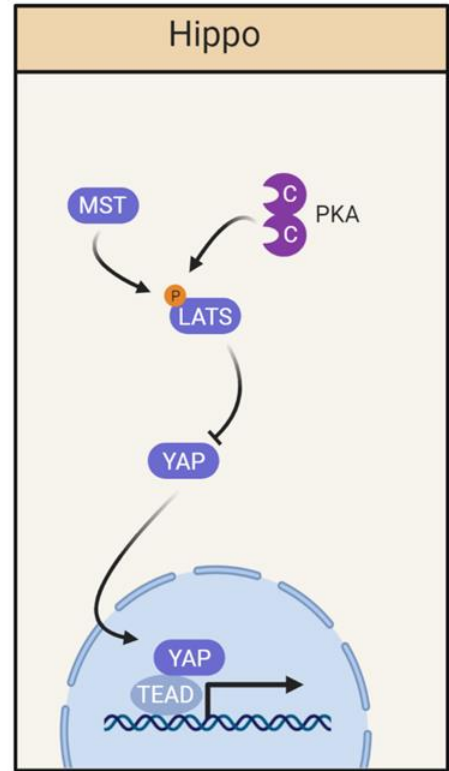
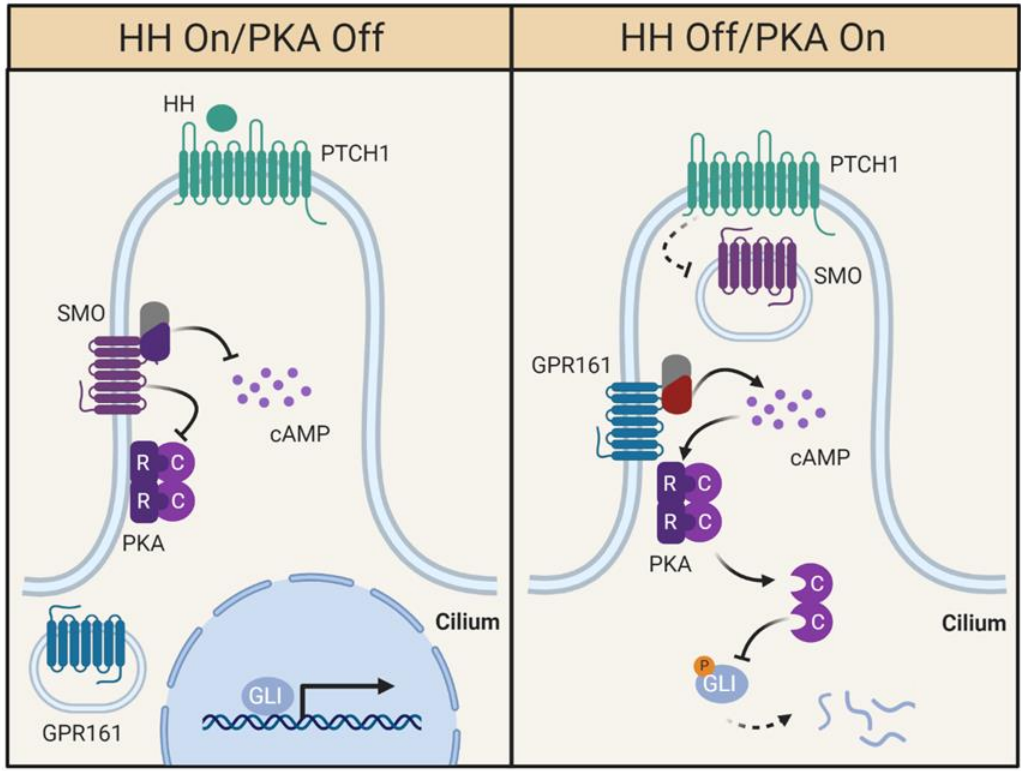
A**B****C**

PKA pathway is also particularly important for the endocrine Gas-PKA pathway signalopathies(Walczak and Hammer, 2015). For instance, β -catenin expression is very strong in adrenal tumors and Carney Complex caused by genetic defects in the Gas-PKA pathway(Almeida et al., 2012). This contributes to dysregulated Wnt signaling and loss of cell cycle control(Almeida et al., 2010). In CRC, activation of the Wnt- β -catenin pathway by Gas-PKA may represent a key event in CRC initiation and progression, whether it is achieved by mutations in *GNAS* or perhaps more often by PGE₂ and COX-2-initiated, Gas-linked GPCR signaling(Castellone et al., 2005; Wu et al., 2019).

Aligned with this perspective, PGE₂ dramatically increases intestinal tumor burden in CRC mouse models, and the inhibition of PGE₂ production with COX-2 inhibitors, such as by non-steroidal anti-inflammatory drugs (NSAIDs), reduces tumor burden(Hansen-Petrik et al., 2002; Kawamori et al., 2003; Wang and DuBois, 2010). In humans, retrospective studies have revealed a reduced incidence of colorectal cancer with prolonged NSAID use and NSAIDs can directly reduce polyp size and number in patients with familial CRC. Unfortunately, the clinical response to NSAIDs is incomplete and long-term use can have limiting toxicities(Brown and DuBois, 2005; Giardiello et al., 1993). Of available NSAIDs, aspirin has been used successfully long-term in cardiovascular disease. In these patient populations, aspirin has also been shown to reduce CRC incidence and mortality. Interestingly, the benefit of aspirin in chemoprevention was most pronounced after 10 years(Chan et al., 2005; Chubak et al., 2015; Drew et al., 2016). One mechanism by which aspirin is thought to reduce mortality is by preventing metastasis, particularly in the progression of local adenoma to metastatic disease(Rothwell et al., 2012). Given the consistent efficacy of aspirin and other NSAIDs in chemoprevention, numerous clinical trials have tested their efficacy in other settings. Notably, NSAIDs have shown efficacy in some adjuvant settings, but failed when operating as single-agents chemotherapeutics(Brown and DuBois, 2005; Wang and DuBois, 2010). The clinical efficacy of NSAIDs as chemopreventive agents, but failure as chemotherapeutics highlights the true complexity of prostaglandin signaling. It is likely that

PGE₂ and others participate in autocrine and paracrine signaling loops that involve both tumor, stroma, and immune components. To this end, Gas-PKA activation, downstream of the proton-sensing GPCR GPR68, has been shown to drive the secretion of IL-6 from cancer associated fibroblasts and subsequent proliferation of PDAC in trans(Wiley et al., 2018). Further, Gas-linked GPCRs, like prostanoid(Böttcher et al., 2018; Pelly et al., 2021; Zelenay et al., 2015) and adenosine receptors(Novitskiy et al., 2008; Visser et al., 2000; Young et al., 2014; Young et al., 2018), contribute to tumor immune evasion and drive immune suppression by dampening T cell responses, as well as interfering with immune cell migration and maturation. For example, these mechanisms can involve direct PKA-mediated phosphorylation of Csk and other components involved T cell receptor signaling and activation, as well as PGE₂-mediated suppression of chemokine production and dendritic cell recruitment (Böttcher et al., 2018; Wehbi and Taskén, 2016). Recent evidence also points to the specific role of PKA C β 2 (an immune specific spliceform) in regulating immune responses in inflammatory disease(Moen et al., 2017). Together, this highlights that the Gas-PKA pathway can participate in tumor initiation and progression, through autocrine and paracrine (oncocrine) mechanisms(Wu et al., 2019). Even in the absence of overt mutations, these oncocrine signals can have important effects throughout the tumor microenvironment, including contributions to a cancer immune evasion and therapeutic resistance (see *Section III, 3.5 Gas-PKA induced therapeutic resistance in cancer*).

3.4 GNAS-PKA as tumor suppressors

Thus far our discussions of the Gas-PKA pathway in cancer have focused on the role of *GNAS* and *DNAJB1-PRKACA* as oncogenes. Paradoxically, however, there are several examples where the Gas-PKA pathway functions as a tumor suppressor. A study by our group unexpectedly found that genetic ablation of *Gnas* or inhibition of PKA in the epidermis were sufficient to drive basal cell carcinoma (BCC), with dramatic expansion of the stem cell compartment residing in the hair follicle. Conversely, overactivation of the pathway with the *GNAS*

R201C mutation drove the same stem cell population to terminal differentiation and exhaustion. Mechanistically, stem cell expansion in the hair follicle is controlled by PKA-mediated repression of YAP and GLI transcriptional activity, with no effect on other stem cell programs like Wnt(Iglesias-Bartolome et al., 2015). Of note, PKA has been shown to repress YAP activity in pancreatic cancer (where PKA functions as an oncogene), but still induce a differentiation phenotype(Ideno et al., 2018). Much like *GNAS* and PKA, YAP has also been shown to behave as either an oncogene or a tumor suppressor depending on the cellular context.

The Hippo pathway controls growth, differentiation, and cell death, balancing these processes to ensure proper organ development and size. In mammals, YAP and TAZ are the main effectors that regulate transcriptional output through binding to transcription factors like TEAD in the nucleus. YAP/TAZ are regulated by phosphorylation from upstream kinases LATS1/2 whereby phosphorylation induces YAP/TAZ cytoplasmic sequestration and subsequent degradation (Figure 10B). LATS1/2 in turn can be regulated by many upstream signals, including GPCRs. Gas-coupled GPCRs activate LATS1/2 to repress YAP/TAZ(Yu et al., 2012). PKA directly phosphorylates LATS1/2 to enhance its kinase activity and mutation of the PKA phosphosites abrogates PKA regulation of LATS1/2 while other regulatory mechanisms remain intact(Kim et al., 2013) (Figure 10B). Physiologically, this is important because PKA is known to induce adipogenesis and neurogenesis through suppression of YAP(Kim et al., 2013; Yu et al., 2013). In general, YAP phosphorylation and inactivation is critical for cell cycle exit and terminal differentiation and it is thought that PKA contributes to this regulation(Kim et al., 2013; Lee et al., 2008). This can explain in part why many neoplasms and cancers characterized by Gas-PKA pathway activation are of well-differentiated histology and typically less proliferative or low-grade (as discussed previously, see *Section III, 3.3 GNAS and PKA link inflammation to cancer initiation*).

In line with the additional effects of Gas on GLI in BCC, low *GNAS* expression is also a feature of the Sonic hedgehog (SHH) subtype of medulloblastoma (SHH-MB). Medulloblastoma

is the most common pediatric brain cancer, with SHH-MB representing 30% of patients (Kijima and Kanemura, 2016). Within this subtype, activation of the SHH pathway (through multiple mechanisms) is thought to drive tumor initiation. Interestingly, SHH-MB patients with low *GNAS* expression have significantly worse prognosis compared to patients with high *GNAS* expression (50% 5-month survival vs 100% 5-month survival). Similar to the hair follicle model, knockout of *Gnas* in neural progenitor cells induced expansion of this stem cell population in neonatal mice that progressively developed into a tumor resembling medulloblastoma by adulthood. The tumors were marked by upregulation of *GLI* and SHH signaling with no effect on the Wnt pathway, a pattern that matches the signature of SHH-MB patients (He et al., 2014). Around 6% of SHH-MB patients actually have *GNAS* mutations, including frameshift and nonsense inactivating mutations (He et al., 2014; Huh et al., 2014; Kool et al., 2014). Perhaps more surprisingly though, around 80% of SHH-MBs overexpress *CXCR4*, which is a Gai-coupled GPCR (Sengupta et al., 2012). These patients are typically younger (~50% were infants) with desmoplastic histology (He et al., 2014). While *CXCR4* is not often mutated, *CXCR4* and its ligand, *CXCL12*, are markers of poor prognosis and earlier onset in other brain tumors, like gliomas (Bian et al., 2007; Calatuzzolo et al., 2006). For these patients, cAMP elevating agents, such as PDE inhibitors have been proposed as potential therapeutic options (Rao et al., 2016).

The importance of *Gas* in the SHH-MB subtype of pediatric brain cancer reflects the fundamental importance of *Gas*-PKA in brain development. As a testament to its importance *Gnas* homozygous knockout mice are embryonic lethal (Yu et al., 1998). Similarly, only 27% of *Prkaca* homozygous knockout mice survive past weaning (Skålhegg et al., 2002). As mentioned previously, both *Cα1* and *Cβ1* are ubiquitously expressed and capable of some degree of compensation. Therefore, it is not surprising that *Cα* and *Cβ1* double knockout mice are embryonic lethal. Restoration of one allele in either gene (*Cα* or *Cβ1*) confers survival, but mice die from severe neural tube defects. Histologically, these mice have an expansion of cell types that are dependent on hedgehog signaling (HH) (Huang et al., 2002).

In a more pathway-specific fashion, PKA is known to regulate HH signaling, both Sonic hedgehog (SHH) and Indian hedgehog (IHH), within the context of cilia. Interestingly, the ciliary structure is essential to proper signaling and development controlled by the HH pathway, a feature that is not shared by other developmental programs. The GLI family of transcription factors are the main effectors that respond to upstream stimulus from HH ligands. In the absence of pathway stimulation, GLI is sequestered and eventually degraded (Carballo et al., 2018). AKAPs position PKA at the base of the cilium where the catalytic subunit phosphorylates GLI to facilitate GLI's proteolytic processing and degradation, ultimately preventing transcriptional activation (Figure 10C). Recent work has demonstrated that the G α s-coupled GPCR, GPR161, contains an AKAP domain enabling it to directly recruit PKA to cilia (Bachmann et al., 2016). Of note, GPR161 is regulated by trafficking and only capable of signaling when it is present on the ciliary membrane (Bangs and Anderson, 2017). Activation of GPR161, among other G α s-coupled GPCRs, is important to trigger production of cAMP and subsequent PKA activation. Generally, PKA activity is quite high when HH ligand is absent (Tschaikner et al., 2020). However, when HH is present, the G α i-like-coupled GPCR, Smoothed (SMO), traffics to the cilium to trigger a reduction in cAMP levels and inhibition of PKA activity (Ogden et al., 2008), allowing full length GLI to activate transcription. This trafficking is regulated by the binding of HH to its receptor Patched homolog 1 (PTCH1) at the membrane, thereby relieving the inhibition on SMO (Bangs and Anderson, 2017). Recent evidence has also demonstrated that SMO can directly inhibit PKA through binding to the free catalytic subunits at the membrane (Arveseth et al., 2021) (Figure 10C). Numerous other GPCRs, such as CXCR4 (G α i-coupled) and PAC1 (G α s-coupled), can also contribute to the modulation of ciliary cAMP levels and PKA activity although some of these roles are complex and cell-type dependent (Amarante et al., 2018; Mukhopadhyay and Rohatgi, 2014; Mykytyn and Askwith, 2017; Niewiadomski et al., 2013; Schou et al., 2015; Tschaikner et al., 2020). Ultimately, the degree of GLI transcriptional output is dependent on the level of PKA activity as a balance of these various inputs (Tschaikner et al., 2020). Consequently, the overexpression

of PKA $C\alpha$ is sufficient to inhibit SHH-stimulated proliferation and induce differentiation (Barzi et al., 2010). Recently several mutations in $C\alpha$ and $C\beta$, which display increased sensitivity to cAMP, show reduced HH pathway activation (Palencia-Campos et al., 2020). Conversely, deletion of *Gas* in the mouse augments SHH signaling with developmental defects that mirror PKA deletion, or deletion of other negative regulators of the SHH pathway (Regard et al., 2013). SHH signaling is particularly important in guiding development of the nervous system and limb patterns, while IHH is important in skeletal development (Bangs and Anderson, 2017). This explains why patients with loss of function mutation in the *Gas*-PKA pathway can develop SHH-MB or severe skeletal deformities as part of Inactivating PTH/PTHrP signaling Disorder (iPPSD) (discussed previously, see *Section III, 2.7 Inactivating PTH/PTHrP signaling Disorder (iPPSD)*). Furthermore, recent reports have described mutations in *PRKACA* that cause skeletal ciliopathies (Hammarsjö et al., 2021; Palencia-Campos et al., 2020).

3.5 Gas-PKA induced therapeutic resistance in cancer

Our discussions have already highlighted some features of the *Gas*-PKA pathway that contribute to therapeutic resistance, including supporting an immune suppressive tumor microenvironment, and clinical evidence of poor outcomes and chemoresistance due to mucinous disease. Here we will focus on additional evidence of the therapeutic resistance potential of the *Gas*-PKA pathway in cancer.

Building on the evidence of *GNAS* and *KRAS* functioning as co-drivers of carcinogenesis, several unbiased studies have identified *Gas* and PKA as key drivers of resistance to mitogen-activated protein kinase (MAPK) pathway inhibition. In metastatic melanoma, about half of all patients have *BRAF* mutations and are primarily treated with BRAF inhibitors (BRAFi). While most patients have clinical responses, approximately 20% of *BRAF* mutant patients have intrinsic resistance to BRAFi (Sanchez et al., 2018). Unfortunately, many initial responders later develop acquired resistance from genetic (60%) or epigenetic and transcriptomic (40%) changes, primarily

through reactivation of MAPK signaling outputs(Kakadia et al., 2018). Several studies have aimed at understanding these mechanisms of resistance and reactivation. Gain-of-function open reading frame and CRISPR activation (CRISPRa) screens in *BRAF* V600E melanomas have been used to identify programs that confer resistance to multiple BRAF and MAPK inhibitors. Surprisingly, GPCRs were consistently among the top hits, many of them being Gas-coupled(Johannessen et al., 2013; Konermann et al., 2015). Downstream, ADCY9 and PKA C α also confer resistance to MAPK inhibitors, with PKA C α having a higher score than even RAF1 (CRAF). Further analysis revealed that PKA via CREB was able to activate transcriptional programs that MAPK normally activates(Johannessen et al., 2013). In melanocytes, there is a fine balance between MAPK control of proliferation and cAMP control of differentiation(Dumaz et al., 2006). This balance is achieved in part because PKA can phosphorylate and inhibit RAF1, while BRAF continues signaling downstream to ERK(Cook and McCormick, 1993; Dhillon et al., 2002). Interestingly, when RAS is mutated, RAF1 predominantly signals to ERK, a program that BRAF control when it is mutated. This type of compensatory cross-talk is the basis for PKA-mediated resistance to MAPK pathway inhibition. Of note, this cross-talk is not present in all cell types, like fibroblasts(Dumaz et al., 2006).

As we discussed previously, inflammatory signaling through COX2-PGE₂-Gas contributes to the pathogenesis of many cancers. Recently, this pathway has also been implicated as a mechanism of resistance to combination BRAF and MAPK pathway inhibition in BRAF V600E colorectal cancer. Using a high-throughput kinase activity screen, SRC was identified as having increased activity after inhibitor treatment. SRC in particular was shown to initiate a proinflammatory autocrine loop mediated by PGE₂ and Gas that was sensitive to COX2 inhibition. Dramatically, the addition of a COX2 inhibitor to 2 or 3 drug combinations targeting the MAPK pathway lead to greater rates of tumor regression in patient-derived xenograft (PDX) resistance models (Ruiz-Saenz et al, submitted). The mechanisms of resistance through COX2-PGE₂-Gas and PKA include survival of cancer stems cells as well as immune suppression(Tong et al., 2018).

In BRAF V600E mutant melanoma, for instance, COX-2 was shown to drive tumor immune escape, a response that underlines the pre-clinical synergy of COX-2 inhibitors in combination with immune checkpoint blockade(Zelenay et al., 2015). Similarly, the ability of PKA to drive tumor immune evasion has also limited the efficacy of other immune-based therapies such as chimeric antigen receptor T cells (CAR-Ts)(Newick et al., 2016). This suppression of CAR-Ts and T cells in general is mediated by PKA/AKAP associations that negatively regulate T cell function(Ruppelt et al., 2007). Interestingly, disruption of this PKA/AKAP interaction can improve CAR-T efficacy and enhance tumor killing(Newick et al., 2016). Building on the understanding of these immune suppressive mechanisms (see *Section III, 3.3 GNAS and PKA link inflammation to cancer initiation*), NSAIDs as well as prostanoid and adenosine receptor antagonists are being investigated as agents to combat tumor immune evasion and enhance the clinical efficacy of immune therapies(Hamada et al., 2017; Leone et al., 2015; Take et al., 2020). Finally, the Gas-PKA pathway has effects on migration and metastasis. This role is somewhat controversial, as PKA has been shown to drive epithelial differentiation, instead of the epithelial to mesenchymal transition phenotypes generally recognized as metastatic(Pattabiraman et al., 2016). However, PKA is also known to play a role in cytoskeletal changes through direct AKAP interactions that are required for many of the hallmarks of cell migration(Howe, 2004). Importantly, it seems that these effects are context dependent, since Gas and PKA serve as a central regulatory hub integrating many signaling pathways and biological functions.

PKA can also contribute to therapeutic resistance by co-opting other normal mechanisms, including energy adaptation. The mitochondria are the main producers of energy in the cell and thus maintaining mitochondrial homeostasis is critically important to cell health. Mitochondrial homeostasis represents a dynamic balance between fusion (joining) and fission (division) events. PKA is particularly well studied in its ability to inhibit mitochondrial fission through phosphorylation of DRP1, a dynamin-like GTPase. DRP1 functions to bring mitochondrial membranes close to each other in order to facilitate fission events. PKA phosphorylation at serine 637 inhibits DRP1

GTPase activity and recruitment to the mitochondria(Chang and Blackstone, 2007). By inhibiting fission, fusion is allowed to proceed, resulting in elongated mitochondria and increased respiration. Increased cAMP and PKA activity has also been linked to decreased mitophagy and ultimately control of mitochondrial recycling, however it remains unclear if this is primarily due to increased fusion or additional effects of cAMP and PKA. Together the actions of the cAMP-PKA pathway on the mitochondria provide a pro-survival signal(Di Benedetto et al., 2018; Ould Amer and Hebert-Chatelain, 2018). Under physiologic conditions of low nutrients, cells elongate mitochondria to compensate. Interestingly, this physiologic adaptation can be exploited by cancer cells which, although somewhat counterintuitive, rely heavily on glycolysis for energy(Vander Heiden et al., 2009). For instance, KRAS transformed cells die in low glucose conditions, but activation of cAMP/PKA rescues their survival under these conditions. PKA-mediated activation of mitochondrial respiration ramps up oxidative phosphorylation and ATP levels(Acin-Perez et al., 2009; Ould Amer and Hebert-Chatelain, 2018; Palorini et al., 2013). Coupled with reduction in reactive oxidative species and increased autophagy, cAMP and PKA metabolically rewire cells to promote survival(Ould Amer and Hebert-Chatelain, 2018; Palorini et al., 2013; Palorini et al., 2016). Under physiologic conditions of low nutrients, PKA also liberates energy from glycogen and lipid stores through direct phosphorylation, as well as transcriptional regulation, of the enzymes involved in these processes(Rogne and Taskén, 2014; Yang and Yang, 2016)(see *Section I, 1.6 Metabolic regulation*). However, it remains unclear to what extent cancer cells exploit these energy sources. Together, energy adaptation mechanisms and pro-survival signals provide some insight to why *GNAS* and PKA serve as biomarkers of therapeutic resistance in many cancer types and further why *GNAS* and *KRAS* often co-mutate in cancer.

Finally, the role of Gαs and PKA in resistance can be seen clinically in breast cancer, a tissue type where *GNAS* mutations are rarely found. One study profiled circulating-free DNA before and treatment with targeted therapy in metastatic, human epidermal growth factor receptor 2 positive (HER2+) breast cancer. Surprisingly, they found that *GNAS* mutations were only

present in patients that were resistant to targeted therapy (Ye et al., 2017). Similarly, *PRKACA* transcripts were elevated in HER2+ patients that were resistant to trastuzimab (HER2 inhibitor) (Moody et al., 2015). *In vitro* models of resistance have also demonstrated that knockdown of *PRKAR2A*, to activate PKA, confers partial resistance to trastuzimab (Gu et al., 2009). Unlike in melanoma, this resistance could not be explained by MAPK pathway reactivation, but rather, by restoration of anti-apoptotic signaling (Moody et al., 2015). In another subtype of breast cancer, estrogen receptor expressing (ER+), patients receive anti-estrogen therapies, such as tamoxifen. Tamoxifen binds to ER α to induce a conformation that prevents its activation and signaling. Interestingly, PKA has been found to phosphorylate the estrogen receptor alpha (ER α), an interaction coordinated by AKAP13. This phosphorylation prevents the inhibitory conformational change induced by tamoxifen and renders tamoxifen ineffective (Bentin Toaldo et al., 2015; Michalides et al., 2004). *GNAS* amplifications have been identified in 20% of HER2+ breast cancers and 13% of hormone receptor positive (HR+) breast cancers (Kan et al., 2010). Although further studies are required, it is tempting to suggest that *GNAS* amplification may serve as a biomarker, predicting resistance to therapy in breast cancer. Here we have highlighted several known mechanisms of therapeutic resistance, but there are certainly additional mechanisms yet to be described. Together, these findings highlight again the diversity and complexity of G α s and PKA signaling and their roles in the diversity of the G α s-PKA pathway signalopathies.

IV. Targeting the G α s-PKA pathway signalopathies

Given the breadth of the G α s-PKA pathway signalopathies, it is tempting to imagine how valuable a magic bullet PKA drug could be, potentially a life changing resource for families with germline G α s-PKA pathway signalopathies, like Carney Complex. While throughout this review we have often distilled diseases down to mutational themes, all circling back to simple activation or inactivation of the G α s-PKA pathway, we have also taken care to highlight the complexity that

underlies all of these signaling events. We must acknowledge the role of local microdomains and specific isoforms that allow PKA to mediate disparate yet parallel functions and of course recognize the diverse inputs that modulate their activity. This complexity may seem like a liability at first glance. However, as we continue to understand the specifics of each signaling defect more deeply, it may provide a unique opportunity to carve out a therapeutic window. Current standard of care for the G α s-PKA pathway signalopathies, particularly those characterized by developmental defects or neoplasia, involve surgical and palliative treatments (Javaid et al., 2019; Sharma et al., 2015). These treatments do not address the true cause of the disease, but instead highlight the value of targeted approaches.

1. Targeting GPCRs and GPCR ligands

When considering how to target the G α s-PKA pathway signalopathies, the natural first step lies at the cell surface with receptors. GPCRs are the target of approximately one-third of all clinically approved small-molecule drugs (Santos et al., 2017). Nearly every family of GPCR has been targeted by either an approved drug or one in clinical development, including both small-molecules and peptides. GPCR drugs have proven to be tremendously effective in diseases such as heart failure and asthma, where drugs targeting β -adrenergic receptors, among others, can improve heart function and cause airways dilation, respectively (Wang et al., 2018; Wendell et al., 2020). As the G α s-PKA pathway signalopathies largely focus on genetic diseases with endocrine and neoplastic phenotypes, here we will focus on the therapeutic potential of GPCRs in these settings, with the ability to modulate both G α s and G α i-coupled receptors with agonists and antagonists, depending on the role of the pathway in the disease. This strategy has already proven effective in several G α s-PKA pathway signalopathies. For example, somatostatin receptor analogs have been used to treat acromegaly for years, and a new analog, pasireotide, was recently approved for Cushing's syndrome (Freda, 2002; McKeage, 2013). Somatostatin is the endogenous peptide ligand for the G α i-coupled somatostatin family of GPCRs (SSTRs), but its

use is limited clinically due to its extremely short half-life. Several peptide analogs have been developed to improve the half-life and with variable selectivity for somatostatin receptor subtypes. In acromegaly, 50-60% of all patients benefit from somatostatin analogs, showing reduced GH and IGF-1 secretion as well as tumor shrinkage, however surgery is often still the first line of therapy(Freda, 2002). In Cushing's syndrome, pasireotide specifically targets SSTR5, which is highly expressed on ACTH-secreting pituitary tumors. Activation of SSTR5 reduces ACTH secretion and subsequently cortisol secretion. However, SSTR5 is also expressed on pancreatic β -cells, where pasireotide inhibits insulin secretion and can exacerbate hyperglycemia, even contributing to the development of diabetes mellitus as a side effect in some patients(Colao et al., 2014; McKeage, 2013). To counteract these adverse events, patients are often administered GLP-1 agonists, targeting the G α s-coupled glucagon-like peptide-1 receptor (GLP1R)(Colao et al., 2014). GLP-1 agonists are commonly used to treat type II diabetes and obesity apart from Cushing's syndrome due to their ability to increase insulin secretion and control appetite(Miller et al., 2014). While GPCRs have proven to be great targets, no clinical drugs are available to target G α s or G α i directly(Campbell and Smrcka, 2018).

Other therapeutic approaches related to GPCRs are aimed at limiting ligand production, as is the case for many of the drugs used to treat Cushing's syndrome and hyperthyroidism, which broadly inhibit steroidogenesis or hormone synthesis to limit hormone production(De Leo et al., 2016; Sharma et al., 2015). In the case of adrenal or pituitary adenomas that automatically secrete hormone, surgical removal the tumor is a common approach(Sharma et al., 2015). For hereditary hyperthyroidism, patients typically receive radioactive iodine or surgery to remove the thyroid, but antithyroid drugs may also be used to interfere with thyroid hormone production as some patients present at a young age(De Leo et al., 2016; Hébrant et al., 2011). Similarly, we have also discussed the use of COX-2 inhibitors as a means to limit prostaglandin production in colorectal cancer (see *Section III, 3.3 GNAS and PKA link inflammation to cancer initiation*). As evident from clinical studies, the side effects of this type of approach can largely limit the

efficacy(Brown and DuBois, 2005). Furthermore, some patients, particularly those with genetic mutation of the PKA holoenzyme are inherently resistant to these types of upstream modulation.

2. Targeting the PKA holoenzyme directly

While most kinases are manipulated by selective protein kinase inhibitors that target the active site cleft, there are a variety of ways to interfere with the PKA holoenzyme. In addition to small molecule inhibitors, such as H89 that mimic ATP(Hidaka et al., 1984), high affinity inhibitory peptides have been derived from the endogenous protein kinase inhibitor (PKI)(Cheng et al., 1985). In addition, analogs of cAMP differentially target Type I versus Type II regulatory subunits(Schwede et al., 2000) and isoform selective peptides can disrupt holoenzyme targeting(Bendzun et al., 2018; Wang et al., 2014; Wang et al., 2015). While many of these strategies hold promise, currently there are no clinical grade drugs that target PKA specifically.

2.1 ATP analog inhibitors of the catalytic subunit. The most commonly used small molecule inhibitors are the high affinity, ATP-competitive, isoquinolinesulfonyl protein kinase inhibitors like H89, H7, and H8(Chijiwa et al., 1990; Engh et al., 1996; Hidaka et al., 1984; Lochner and Moolman, 2006), natural product derivative KT-5720(Kase et al., 1987) or staurosporine(Meggio et al., 1995). Although these are very effective inhibitors they have low specificity and inhibit several other kinases in the AGC-family of protein kinases and hence should not be considered specific inhibitors(Lochner and Moolman, 2006; Murray, 2008). Of course, these inhibitors also do not discriminate between the PKA isoforms, thus limiting their clinical translatability.

2.2 Peptide inhibitors of the catalytic subunit. To overcome the concerns of specificity, derivatives of the substrate competitive, heat stable, protein kinase inhibitor (PKI, encoded by *PKIA*, *PKIB*, and *PKIG*), can be used. PKI (5-24) has low nanomolar inhibition constants and is

absolutely specific for PKA(Cheng et al., 1985). PKI(5-24) can be modified by myristylation which allows for membrane permeation(Eichholtz et al., 1993); however, it can also be expressed recombinantly in cells to overcome delivery issues. A hydrocarbon-stapled version of a PKI-derived sequence provides another excellent tool as a membrane permeable, highly selective inhibitor of the catalytic subunits acting with low sub-nanomolar affinity(Manschwetetus et al., 2019).

2.3 Bisubstrate inhibitors of the catalytic subunit. A combination of the two co-substrate inhibitors, ATP and peptide, would be the logical consequence and indeed such bisubstrate analogue inhibitors termed ARC-type inhibitors have been developed by linking an adenosine analog (either an adenosine derivative or ATP inhibitor) and an arginine rich peptide(Lavogina et al., 2010). A series of ARC-type inhibitors have been designed with low nanomolar or even picomolar affinities and efficacy against PKA C α and C β (Enkvist et al., 2006; Enkvist et al., 2007; Lavogina et al., 2010; Nonga et al., 2020; Ricouart et al., 1991). Recent work has demonstrated that ARC inhibitors can also be engineered to have greater selectivity for mutant C β over wild-type C β (Nonga et al., 2020). While ARC inhibitors have primarily been used as tool compounds, including fluorescently conjugated ARCs, recent advances have drastically improved their pharmacokinetic properties making them poised for future application in a therapeutic context(Lavogina et al., 2010).

2.4 Targeting the regulatory subunits with cAMP analogs. In contrast to the ATP analog inhibitors that target the catalytic subunit, cAMP analogs have been engineered with specificity for the two classes of regulatory subunits (RI and RII). Both activators and inhibitors have been developed(Christensen et al., 2003). Achieving PKA regulatory subunit specificity has been a special challenge as other proteins such as cGMP-dependent protein kinases, EPACs, CNG channels, PDEs, and cyclases all have cyclic nucleotide binding (CNB) domains(Berman et al., 2005; Holz et al., 2008) (see Section I, I.7 Other cAMP effectors). By modifying the oxygens of

the cyclic phosphate, chemists generated cAMP agonists (Sp-analogs) and antagonists (Rp-analogs). Global inhibition can be achieved with the Rp analogs, which bind to but do not promote dissociation of the holoenzyme(Christensen et al., 2003; Rothermel and Parker Botelho, 1988). By comparing the activity of Type I inhibitors, like Rp-8-Br-cAMPS, with the activity of nonselective inhibitors, like Rp-cAMPS, it is possible to discriminate between the activities of the two holoenzymes(Christensen et al., 2003; Farquhar et al., 2008; Gjertsen et al., 1995). Similarly, the combination of different agonists can achieve some level of isoform specific activation, but this still remains a challenge in the field(Robinson-Steiner and Corbin, 1983). However, leveraging regulatory subunit agonists and antagonists has facilitated the high quality purification of PKA holoenzymes as well as free regulatory subunits(Bertinetti et al., 2009; Hanke et al., 2011). Unfortunately, many of these cAMP analogs suffer from poor membrane permeability, limiting their efficacy if delivered extracellularly. To overcome this, membrane permeable versions of the cAMP analogs have been developed as prodrugs. When cleaved by cytosolic esterases, the analog is free to act inside the cell(Chepurny et al., 2013; Schwede et al., 2015). Care must be taken, however, because the effective concentration of the released nucleotide inside the cell may vary and extremely high levels of cAMP may perturb other cyclic nucleotide signaling.

2.5 Inhibitors of AKAP binding. PKA specificity is also highly dependent on targeting to specific sites in the cell. Targeting is typically mediated by binding to A Kinase Anchoring Proteins (AKAPs) that contain a high affinity helical binding motif that interacts with the dimerization/docking (D/D) domains of the regulatory subunits. Naturally, peptides have been developed to disrupt this interaction, non-selectively perturbing the interactions with both Type I and Type II interactions (Carr et al., 1992; Herberg et al., 2000). Over time, this led to development of peptides specific to Type I or Type II although these peptides still suffered from limited cell permeability(Calejo and Taskén, 2015). Now, isoform-specific cell-permeant stapled peptides have been engineered that can selectively disrupt the targeting of Type I and Type II

holoenzymes(Bendzun et al., 2018; Kennedy and Scott, 2015; Wang et al., 2014; Wang et al., 2015). Unfortunately, these peptides still lack clinical utility due to their unfavorable pharmacokinetics and relative inability to distinguish among specific AKAP interactions(Calejo and Taskén, 2015). Reagents have also been developed to disrupt other AKAP binders, such as PDEs and phosphatases, but as AKAPs have multiple binding partners, it has been difficult to translate this disruption to direct modulation of cellular consequences(Bucko and Scott, 2020; Omar and Scott, 2020). To begin to answer these difficult questions of microdomain dynamics, a promising new tool has been developed using AKAP targeting sequences as a means to localize drug delivery to specific PKA microdomains, such as those present at the centrosome. While this approach called Local Kinase Inhibition (LoKI) is still in its infancy, conceptually it holds a lot of promise in understanding AKAP interactions more directly and ultimately enhancing the specificity of PKA modulation(Bucko et al., 2019). Finally, small molecule AKAP disrupters represent another promising approach with potential for clinical translation. Protein-protein interactions have been notoriously difficult to target with small molecules, but the advances in high-throughput screening have made this approach more feasible(Calejo and Taskén, 2015). Several groups have applied these approaches recently to identify disrupters of AKAP interactions((Gold et al., 2013; Schächterle et al., 2015). Although there are real challenges, huge potential lies in the ability to apply these small molecule disrupters to specific AKAP complexes in diseases settings, for instance disruption of the PKA/AKAP interactions that mediate immune suppression in T cells in cancer (see *Section 3.5 Gas-PKA induced therapeutic resistance in cancer*).

2.6 Emerging Approaches. As we discussed, many of the Gas-PKA pathway signalopathies are driven by specific hotspot point mutations, like GNAS R201C or PRKACA L206R, so generating mutation specific drugs could be a viable therapeutic option. Recently, this strategy has shown clinical promise, most notably by targeting the mutant cysteine of KRAS G12C with drug electrophiles(Ostrem et al., 2013). It has been proposed that this same method could

also be applied to target GNAS R201C mutants in cancer(Visscher et al., 2016). While PKA is not amenable to targeting with drug electrophiles, the PKA C α L206R mutation does have reduced affinity for its endogenous inhibitor PKI compared to wild-type PKA C α while the small molecule inhibitor H89 still retains its efficacy. This opens the possibility of exploiting this differential binding to selectively target PKA C α mutants. However, significant challenges remain as H89 retains its efficacy because it is an ATP competitive inhibitor. As alluded to previously, this class of drug is susceptible to multiple off target effects on other kinases, making it a liability in the clinical setting(Luzi et al., 2018). In an effort to identify drugs that do not act as ATP competitive inhibitors of PKA, high-throughput screening platforms based on fluorescence polarization have been developed and proven capable of identifying allosteric agonists and antagonists(Brown et al., 2013; Saldanha et al., 2006). Some promise has also been shown for antisense oligonucleotides targeting R1 α in combination with chemotherapy in cancer(Almeida et al., 2012; Goel et al., 2006). The mechanism is not completely understood, but the compensatory increase in R1 β protein could be important in restoring the balance of Type I and Type II holoenzyme signaling(Nesterova et al., 2000). Similarly, while many of the PKA C α mutations have been linked to altered substrate profiles and decreased preference towards canonical substrates. It is plausible that restoring activity towards key substrates may also serve as an additional therapeutic avenue(Lubner et al., 2017).

3. Degradation of pathway components

Another promising approach to targeting the Gas-PKA pathway directly is in targeting the stability of pathway components. This strategy has garnered huge interest in the past few years with the development of small molecule inhibitors termed proteolysis targeting chimeras (PROTACs). PROTACs consist of an element targeting the protein of interest as well as an element target an E3 ubiquitin ligase that are linked together, facilitating target degradation through endogenous ubiquitin-proteasome system (UPS) machinery (Gao et al., 2020). This

technology has been hailed for its exquisite specificity and ability to target “undruggable” proteins because it can take advantage of any binding site on the protein and does not require that the binding interferes with catalytic activity(Mullard, 2021). PROTACs hold particular promise for targeting the G α s-PKA pathway because several components of the pathway are already known to be regulated by the UPS, including GPCRs, G proteins, PKA, PDEs, and AKAPs(Rinaldi et al., 2015). For instance, under physiological conditions, the UPS contributes to desensitization of GPCRs at the plasma membrane after stimulation(Rinaldi et al., 2015; Skieterska et al., 2017). Furthermore, levels of G α s and PKA catalytic subunits are also regulated by ubiquitination and degradation in response to pathway stimulation(Nagai et al., 2010; Naviglio et al., 2004; Rinaldi et al., 2019). In contrast to desensitization mechanisms that control receptor and G protein in response to stimulus, the UPS can also provide feedforward regulation of pathway activity, as is the case for regulation of PKA regulatory subunits. Specifically, regulatory subunits associate with Praja2, a RING E3-ubiquitin ligase that also functions as an AKAP. When PKA becomes activated, the catalytic subunit dissociates from the regulatory subunits and phosphorylates Praja2, stimulating the ubiquitination and degradation of the regulatory subunits, thereby potentiating PKA activity(Lignitto et al., 2011). Interestingly, PKA is also capable of regulating the stability of other proteins through the UPS(VerPlank et al., 2019). For instance, cAMP signaling has been shown to down-regulate levels of p300 and SIRT6 through their ubiquitin-dependent proteasomal degradation(Jeong et al., 2013; Kim and Juhn, 2015).

To date, PDE4 and CBP/p300 represent the only G α s-PKA pathway components with small molecule degraders designed against them(Ohoka et al., 2017; Vannam et al., 2021). As PROTACs and targeted degrader technology advances, components of the G α s-PKA pathway certainly represent promising targets. With the first PROTACs now demonstrating positive clinical responses and favorable safety profiles (Mullard, 2020), there is also tremendous potential to translate these compounds into clinical drugs for use in the G α s-PKA pathway signalopathies.

4. Targeting PKA indirectly

Given the significant hurdles in targeting PKA directly, another therapeutic strategy is to modulate cAMP levels. The tool compound forskolin, an activator of adenylyl cyclase (Seamon et al., 1981), is commonly used while adenylyl cyclase inhibitors are less common (Bitterman et al., 2013). PDE targeting drugs have been much more tractable clinically. Inhibitors targeting cAMP-hydrolyzing PDEs are approved for the treatment of cardiovascular, airway, and inflammatory diseases (PDE3 and PDE4 inhibitors), but to our knowledge have not been used to treat any Gas-PKA pathway signalopathies. Unfortunately, these drugs are largely limited by side effects (Boswell-Smith et al., 2006). Currently there are several compounds in development aimed to minimize side effects by targeting specific PDE4 isoforms as well as PDE7 and PDE8 (Martinez and Gil, 2014). For the Gas-PKA pathway signalopathies, the application of cAMP-specific PDE inhibitors is particularly promising for the treatment of SHH-MB (Rao et al., 2016). While many of the Gas-PKA pathway signalopathies exploit activation of the Gas-PKA pathway, PDE activators may also have therapeutic benefit. Recently, a novel positive allosteric modulator of PDE4 showed promise in models of autosomal dominant polycystic kidney disease (ADPKD), a disease driven by chronically elevated cAMP (Omar et al., 2019). Other mechanisms of targeting PKA indirectly include activation of phosphatases. Results *in vivo* have suggested that inhibition of PKA via activation of the phosphatase PP2A may be a valuable therapeutic approach in small cell lung cancer (SCLC) (Coles et al., 2020). However, given the relative unselectivity of phosphatases like PP2A, further work is necessary to establish the translational potential of this type of therapeutic approach.

5 Synthetic lethality approaches

Finally, given the complexity of the Gas-PKA pathway, particularly in polygenetic diseases like cancer, finding specific, context-dependent, vulnerabilities could be extremely valuable. Synthetic lethality stems from the idea that in cancer if you target one gene program either

genetically or with a drug, you may shift the reliance of that cancer to another program. By specifically leveraging the vulnerabilities of the cancer cell over normal cells, targeting a secondary program will ultimately prove lethal to the cancer while sparing the normal tissue(Kaelin, 2005). The most notable example of this is the use of poly(ADP-ribose) polymerase (PARP) inhibitors in *BRCA1/2* mutant cancer that are DNA damage deficient(Ashworth and Lord, 2018). Synthetic lethalties are largely identified by large chemical or genetic screens(Kaelin, 2005). To this end, recent work by our group has demonstrated that this approach is feasible to identify synthetic lethal vulnerabilities in a Gαq-driven cancer, uveal melanoma, and is now the subject of ongoing clinical trials(Feng et al., 2019; Paradis et al., 2021) (ClinicalTrials.gov, NCT04720417). Furthermore, recent work has also shown that cancer cell growth driven by the DNAJ-PRKACA fusion protein in liver cells can be selectively targeted by HSP70 inhibitors, due to an scaffolding interaction unique to the fusion protein(Turnham et al., 2019). As we discussed throughout this review, alteration of the Gαs-PKA pathway is accompanied by unique phenotypes. Ultimately, these unique cell states could be leveraged to exploit single and multimodal synthetic lethal therapies for the treatment of the Gαs-PKA pathway signalopathies.

Conclusion

For the first time, we have defined the Gαs-PKA pathway signalopathies as a family of germline, post-zygotic, and somatic diseases driven by dysregulation of the Gαs-PKA pathway. The Gαs-PKA pathway signalopathies cover a diverse range of pathophysiology and this diversity mirrors the physiological roles of Gαs-PKA pathway signaling, contributing to fundamental processes from gene transcription and intracellular trafficking to cellular differentiation and organismal development. On a cellular level, owing to isoform specificity and scaffolding interactions, PKA is localized to distinct microdomains. This feature enables PKA to integrate signals from multiple inputs and participate at multiple levels within the same physiological process. Similarly, PKA is also uniquely poised to mediate the same molecular action across

multiple areas of physiology (i.e. regulation of ion channels). Consequently, the Gas-PKA pathway signalopathies can be characterized by diseases that exploit either pathway activation or inactivation. We find that the major themes of activation include aberrant upstream inputs (GPCR and Gas activation) as well as disruption of PKA holoenzyme stability (loss of R1 α or loss of R:C contacts), with recent evidence also suggesting the role of an altered PKA substrate profile. Conversely, there are many ways to inactivate the pathway, affecting almost every signaling node without consistent hotspot mutations.

From a clinical perspective, these mutational themes are primarily represented in monogenetic, endocrine, bone, and metabolic disorders, largely altering hormone function and developmental events. With this review, we now highlight how the same mutational themes, depending on the tissue and cell context, enable the Gas-PKA pathway to act as both an oncogenic driver and a tumor suppressor in cancer. Dysregulated signaling through the Gas-PKA pathway is accompanied by unique phenotypes in cancer, including enhanced mucin production, which makes *GNAS*, in particular, a promising biomarker. However, as genomics has informed us about the ability of *GNAS* to cooperate with *KRAS* in cancer initiation, it has also failed to appreciate the complex connections within the tumor microenvironment. These complex interactions ultimately contribute to the ability of the Gas-PKA pathway to drive therapeutic resistance.

Naturally, PKA has been the target of significant drug development efforts, but unfortunately kinase cross-reactivity and complex biology have proven to be substantial hurdles. Conceptually, the tetrameric holoenzyme structure provides a unique landscape for bispecific compounds to flourish. An idea that could even extend to targeting of specific microdomains using AKAP motifs. Promising new approaches are aimed at targeting the pathway with degraders as well as leveraging context specificity to target synthetic lethal interactions. With these new perspectives on the capabilities of the Gas-PKA pathway and its promise as a therapeutic target, there is a tremendous opportunity to explore new connections among the Gas-PKA pathway

signalopathies, linking seemingly disparate fields through a common signaling mechanism. More importantly, by synthesizing the field we hope to provide a blueprint for therapeutic advances in treating the human Gas-PKA pathway signalopathies.

Acknowledgements

Chapter 1, in full, is a reprint of an accepted manuscript that is currently under revision with *Pharmacological Reviews*. Ramms, D.J., Raimondi, F., Arang, N., Herberg, F. Taylor, S.S., and Gutkind, J.S. (2021). Gas-PKA pathway signalopathies: The emerging genetic landscape and therapeutic potential of human diseases driven by aberrant Gas-PKA signaling. The dissertation author is the primary investigator and author of this paper.

We would like to acknowledge Dr. Alexandr Kornev at the University of California San Diego for his help preparing PKA structure graphics. We would also like to thank Dr. Daniela Bertinetti at the University of Kassel and Dr. Bjørn Steen Skålhegg at the University of Oslo for their helpful discussions related to cAMP analogs and mouse models of PKA, respectively. Finally, we would like to acknowledge the use of BioRender.com in creating many of our graphics.

Methods

Normal gene expression analysis

Median gene-level expression counts for normal tissue were download from the GTex Portal [<https://www.gtexportal.org/home/datasets>] (v8, June 2017). Results were curated for pathway genes provided in Table S1. For organs with multiple data entries (i.e. Brain - Amygdala, Brain - Anterior cingulate cortex...) values were averaged to represent whole organ gene expression. All values were represented in transcripts per million (TPM).

Variant annotation and interpretation

All available variant coordinates were retrieved from the ClinVar database [<https://www.ncbi.nlm.nih.gov/pubmed/31777943/>] as of February 2021. Variants were called using the human genome version GRCh37 as a reference [https://ftp.ncbi.nlm.nih.gov/pub/clinvar/vcf_GRCh37/]. Variants were then annotated on Uniprot canonical sequences through Variant Effect Predictor [<https://pubmed.ncbi.nlm.nih.gov/27268795/>]. The ClinVar variant summary file [https://ftp.ncbi.nlm.nih.gov/pub/clinvar/tab_delimited/] was used to retrieve variant curations, including "ClinicalSignificance", which classifies variants as either pathogenic (or likely pathogenic), risk factors, benign or variants of unknown significance based on supporting evidence. Disease phenotype associations were retrieved using the information provided in the "PhenotypeList" classification. An interaction network was obtained by querying the Reactome Functional Interaction (FI) network [<https://pubmed.ncbi.nlm.nih.gov/28150241/>] and the STRING database [<https://pubmed.ncbi.nlm.nih.gov/30476243/>] with the list of genes involved in the PKA pathway (Table S2). Networks were implemented using the Cytoscape apps Reactome FIVIZ [<https://www.ncbi.nlm.nih.gov/pmc/articles/PMC4184317/>] and stringApp [<https://pubmed.ncbi.nlm.nih.gov/30450911/>] (confidence score > 0.75). The diameter of the nodes in the network were scaled proportionally to the number of variants classified as pathogenic, likely pathogenic, or risk factor. Pie charts with PhenotypeList classifications, when available, were added to network nodes through enhanced Graphics Cytoscape app [<https://pubmed.ncbi.nlm.nih.gov/25285206/>]. Phenotype labels for the pie chart representation were given through the following criteria: if "Acrodysostosis" matched PhenotypeList, label="Acrodysostosis"; if "Long QT syndrome" matched PhenotypeList, label="Long QT syndrome"; if "pseudohypoparathyroidism" or "PSEUDOHYPOPARATHYROIDISM" matched PhenotypeList, label="Pseudohypoparathyroidism"; if "McCune-Albright syndrome" matched PhenotypeList, label="McCune-Albright syndrome"; if "Cardiac" or "Cardio" matched PhenotypeList, label="Cardiovascular phenotype"; if "PITUITARY TUMOR 3" or "Pituitary

adenoma 3" matched PhenotypeList, label="Pituitary adenoma"; if "CARDIOACROFACIAL DYSPLASIA 1" or "CARDIOACROFACIAL DYSPLASIA 2" matched PhenotypeList, label="CARDIOACROFACIAL DYSPLASIA"; if "Thrombocytopenia" matched PhenotypeList, label="Thrombocytopenia"; if "Dyskinesia" or "Dystonia" or "Striatal degeneration" matched PhenotypeList, label="Movement disorders".

Pathogenic mutations were annotated on protein canonical sequence diagrams through the Lollipop software [<https://www.ncbi.nlm.nih.gov/pmc/articles/PMC4973895/>]. Pathogenic mutations were then mapped on the 3D structure whenever available, alternatively we displayed any mutation available for a given interface of interest (i.e. AKAP10). Protein Data Bank (PDB) identifiers for structures displayed are as follows: β_2 AR-Gas (PDB: 3SN6), adenylyl cyclase-Gas (PDB: 1AZS), PKA RI α -Ca (PDB: 5JR7), and AKAP10-RI α (PDB: 3IM4). Prediction of functional consequences of mutations at 3D interaction interfaces was then performed through Mechismo [<https://pubmed.ncbi.nlm.nih.gov/25392414/>] using default parameters.

Fusion transcript analysis

Fusion events were retrieved from the Fusion GDB database [<https://pubmed.ncbi.nlm.nih.gov/30407583/>]. Results were curated using the gene list provided in Table S4. The number of fusions identified for each gene was counted across cancer tissue types. Cancer tissue type data was pooled based on organ (i.e. "Lung" represents lung adenocarcinoma and lung squamous cell carcinoma). Drawing of fusion event statistic for the *GNAS* gene model were obtained through the ensembl db [<https://pubmed.ncbi.nlm.nih.gov/30689724/>] and gviz [<https://www.springer.com/gp/book/9781493935765>] R libraries.

Analysis of cancer mutations

For analysis of residue mutation frequency, gene specific data was downloaded directly from the gene variant section of the COSMIC database in February 2021, COSMIC v92.

Mutations were called with respect to the reference genome GRCh38 and all available mutations were included. Direct access links are provided below.

For *GNAS*: [<https://cancer.sanger.ac.uk/cosmic/gene/analysis?In=GNAS#variants>].

For *PRKACA*: [<https://cancer.sanger.ac.uk/cosmic/gene/analysis?In=PRKACA#variants>].

For *PRKACB*: [<https://cancer.sanger.ac.uk/cosmic/gene/analysis?In=PRKACB#variants>].

For *PRKAR1A*: [<https://cancer.sanger.ac.uk/cosmic/gene/analysis?In=PRKAR1A#variants>].

Mutation counts were pooled by residue and converted to frequencies. Only residue frequencies greater than 1% for their respective gene were considered recurrent for plotting purposes (Table S3).

For gene mutation analysis, whole genome screen data was downloaded directly from the COSMIC database [<https://cancer.sanger.ac.uk/cosmic/download>] in May 2020, COSMIC v91. Mutation frequencies were curated across all available tissues. The corresponding “HGNC_ID” (Table S5) was used to extract gene-level mutation data. The data was then collapsed using the corresponding “ID_Sample” to ensure that no given sample was counted more than once. Gene family-level mutation frequencies were generated by counting unique patient samples harboring at least one mutation in a family gene member (family gene members listed in Table S5). The total number of individual pathway mutations per patient sample was also counted across tissues using “ID_Sample” and the “Pathway Family” gene set. All available mutations were considered for each analysis.

CHAPTER 2

Genetic models of G α s-PKA-driven cancers

Abstract

While the field of oncology drug discovery has increasingly shifted towards precision medicine approaches, aimed at understanding the unique vulnerabilities of a given tumor, it has become clear that our understanding of human disease is limited by the relevance of our models. Pre-clinical mouse models in particular need to recapitulate the complex interactions of genetics, inflammatory and immune responses, and environmental exposures, among others. Here we focus on the genetic interaction of *GNAS* and *KRAS* mutations identified in patients of several tissue contexts. We develop three robust mouse models that illustrate the ability of *GNAS* to cooperate with *KRAS* to drive tumor initiation and carcinogenesis. Further, we recapitulate clinical cancer phenotypes, including cystic histology and enhanced mucin production. These models provide a proof of principle for the importance of *GNAS* mutations in cancer, and the tools to rapidly address their underlying disease-mechanisms. Ultimately, these models provide a platform for the development of therapeutic interventions in neoplastic diseases arising from multiple tissue contexts.

Introduction

Cancer represents one of the leading causes of death worldwide. An estimated 40% of all people will develop cancer in their lifetime with over 600,000 lives lost in 2020 alone (NCI, 2020). Statistics are improving for many cancers, such as breast cancer where the 5-year survival rates are around 90%, or colorectal cancer where preventative screening has enabled early detection and treatment. Other cancers such as pancreatic cancer, however, continue to claim lives with a dismal 5-year survival rate below 11%(SEER, 2021). We have long sought ways to specifically target cancer cells while sparing normal cells. Early therapeutic strategies leveraged, cancer's rapid rate of cell division as a means to specifically target these highly proliferative cells(Hanahan and Weinberg, 2000). The utilization of toxic chemotherapeutic agents has proven effective for many patients. In fact, many of these agents have persisted as the standard of care for years

despite their severe adverse effects(DeVita and Chu, 2008). In 1976, *Src* was first described as an oncogene, bringing with it a revolutionary perspective viewing cancer as a genetic disease(Stehelin et al., 1976). In recent years, this concept has given rise to the fields of genomic and precision medicine which aims to understand therapeutic vulnerabilities that are unique to each patient, largely through identification of cancer mutations(Hodson, 2016). Understanding of driver oncogenes led to the development of targeted therapies. By targeting a known driver, this approach has proven to be extremely effective in cases such as the use of a specific inhibitor of the Bcr-Abl fusion protein in leukemia(Druker et al., 2001). However, the ability of cancer to adapt and evolve rapidly gives rise to resistance, such as in *BRAF* V600E-driven melanomas that initially respond to BRAF inhibitors, but rapidly acquire resistance(Giunta et al., 2020). These failures have highlighted the true complexity of human cancer, a disease that is influenced by many factors, including genetic, environmental, inflammatory, and immunological effects. In order to further understand this complexity and predict its response to therapy, better cancer models are desperately needed(Mak et al., 2014).

In vivo mouse models are a mainstay in the cancer field, providing a platform to study cancer mechanisms in the context of a whole organism. Selection of an appropriate model is of the utmost importance because it ultimately informs the success and failure of clinical interventions(Mak et al., 2014). Multiple types of mouse models exist including immunodeficient xenograft models, syngenic implantable models, spontaneous chemical models, and genetically engineered mouse models (GEMs)(Frese and Tuveson, 2007; Olson et al., 2018). While each model has its advantages and disadvantages, GEMs excel in their ability to recapitulate specific molecular events, like gene mutations, in both a tissue-specific and temporally-controlled manner. Ideally, this specificity results in a murine cancer that mirrors the human histology and disease progression(Herter-Sprie et al., 2013).

As discussed in Chapter 1, the alteration of the Gαs-PKA pathway has emerged as a common theme among many germline neoplastic diseases as well as somatic cancers.

Specifically, mutation of *GNAS*, encoding the Gas G protein of G protein coupled receptors (GPCRs), is one of the most common pathway alterations, with mutation in 4% of all tumors(O'Hayre et al., 2013). Work by our group and others have highlighted, that like many oncogenes, *GNAS* does not operate in isolation, but rather requires activation of additional oncogenic drivers or loss of tumor suppressors to induce transformation(Ideno et al., 2018; Wilson et al., 2010; Zhao et al., 2018). Profiling of numerous malignancies, including pancreatic, appendix, and colorectal cancer, revealed the co-occurrence of *GNAS* mutations with *KRAS* mutations(Amato et al., 2014; Ang et al., 2018; Molin et al., 2013; Yamada et al., 2012). Here we model the mutational cooperation of *GNAS* and *Ras* in the mouse skin using chemical and genetic approaches. We reveal that *GNAS* and *Ras* function together to drive tumor initiation and cystic morphology. Finally, as a proof of principle, we utilize our transgenic platform to generate a murine intestinal organoid model that displays unique phenotypes consistent with patient histology.

Results

Co-occurrence of GNAS and RAS mutations

While many studies have observed that *GNAS* mutant patients often harbor *KRAS* mutations, we first aimed to validate this genetic interaction using a large pancancer dataset of over 10,000 patients(Cerami et al., 2012; Gao et al., 2013; Zehir et al., 2017). Dramatically, we found that *KRAS* was the top hit among mutations that co-occur with *GNAS* mutations ($p= 3.48e-22$) (Figure 11A). Interestingly, other top hits that co-mutate with *GNAS* included transcriptional and epigenetic regulators like *ASXL2*(Gelsi-Boyer et al., 2012; Micol et al., 2017) and *KMT2D*(Alam et al., 2020; Ardeshir-Larijani et al., 2018), which both function as tumor suppressors and have been correlated with poor patient outcomes in cancer. Next we performed the reciprocal co-occurrence analysis and queried for genes that co-mutated with *KRAS*. Consistent with our previous analysis, *GNAS* mutations significantly co-occurred with *KRAS* mutations ($p= 2.57e-8$) (Figure 11B). Interestingly, *GNAS* mutations ranked just below co-

Figure 11. Co-occurrence of *GNAS* and *KRAS* mutations. A) Mutations that co-occur with *GNAS* mutations in a large pancancer dataset (total n=10,945)(Zehir et al., 2017). The p-value ($-\log_{10}$ transformed) is plotted as a function of the ratio of patient percentages with and without the respective mutation pair (\log_2 transformed). Points on the right side of the axis represent co-occurring mutations while points on the left side represent mutually exclusive mutations. Significant relationships ($q < 0.05$) are plotted in black, while those that do not reach significance are in gray. B) As in A), mutations that co-occur with *KRAS* mutations. *GNAS* mutations (n=165) and *KRAS* mutations (n=1,670) C) Frequency of *GNAS-KRAS* co-mutation across cancer types. Purple bars highlight mucinous (Muc) cancer types. IPMN=intraductal papillary mucinous neoplasm. D) Oncoprint plot of all *GNAS* mutant cancers overlaid with corresponding *KRAS* mutations (n=76). Each column represents one patient and is colored by mutation type. Driver missense mutations (dark green) predominate in *GNAS-KRAS* co-mutant cancers. E) Enrichment of mutations with *KRAS* transcriptional activation (shown in red) in cancer cell lines. Each column represents one cell line, with black coloring indicating a mutation is present. *KRAS* mutations enrich with G α -PKA pathway mutations, including those in *GNAS*, PKA C α (*PRKACA*), and *PDE4D*.

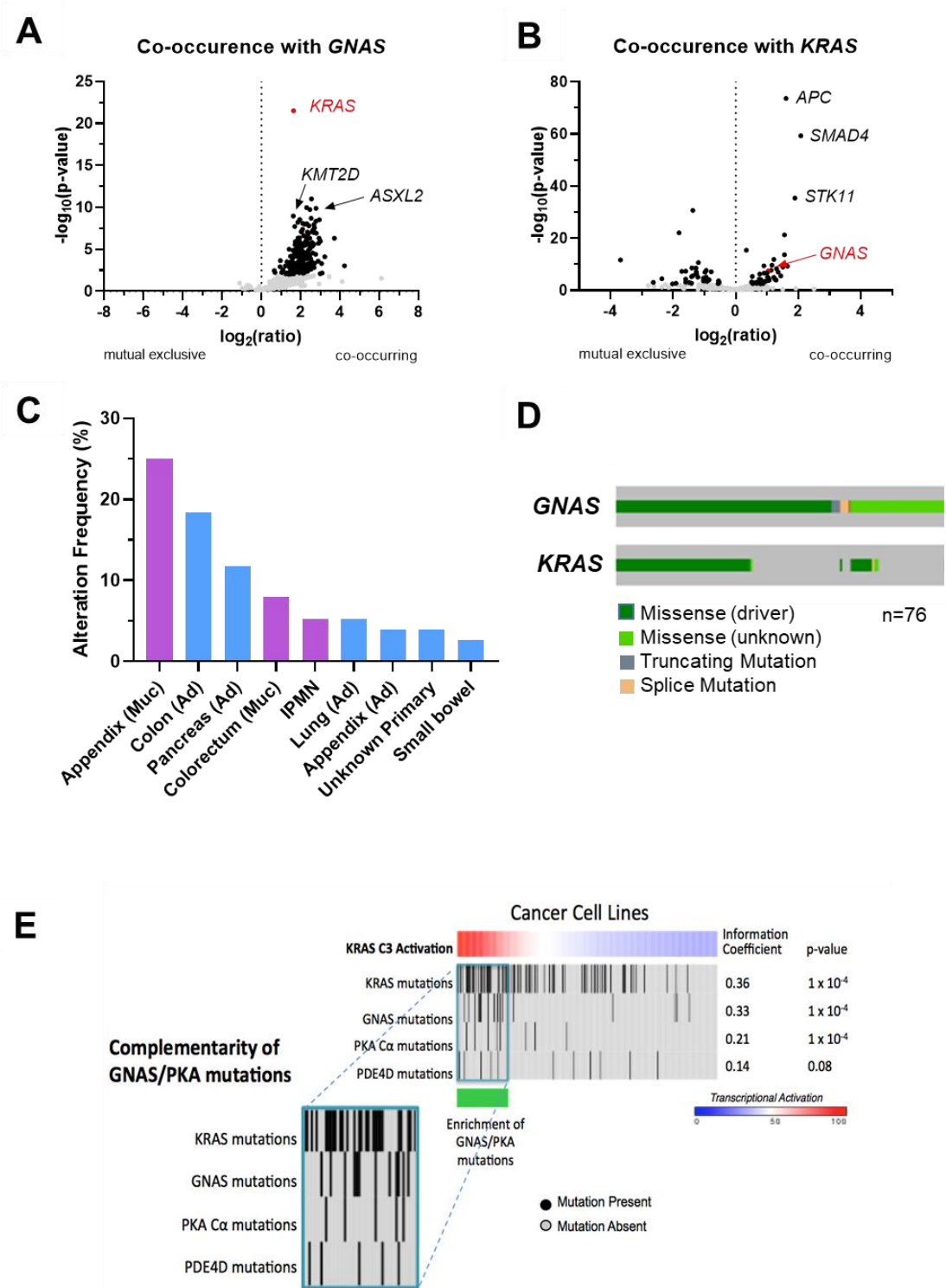

occurrences with several other well-known tumor suppressors, including *APC*, *SMAD4*, and *STK11*. *APC* and *SMAD4* primarily co-occur with *KRAS* in colorectal cancer (Schell et al., 2016), while *KRAS* and *STK11* mutations commonly co-occur in lung cancer (Facchinetti et al., 2017). In line with previous literature, we find *GNAS* and *KRAS* mutations predominated in cancers of the appendix, pancreas, and both the small and large intestines (Figure 11C). Interestingly, these include several mucinous subtypes which has been described previously (Nishikawa et al., 2013). The majority of the mutations in both *KRAS* and *GNAS* represent hotspot activating driver mutations (Figure 11D). Interestingly, *KRAS* driver mutations also co-occurred less frequently with *GNAS* mutations of unknown function. While *GNAS* mutations are the most frequent alteration observed among members of the G α s-PKA pathway, we also asked if this pattern of co-occurrence extended to other pathway members. To do this, we utilized data from cancer cell lines and stratified them by *KRAS* activation on the transcriptional level (*KRAS* C3 Activation) (Kim et al., 2017). The *KRAS* C3 Activation signature was previously generated based on the top 1,000 differentially expressed genes in response to isogenic mutation of *KRAS* G12V decomposed across 750 cancer cell lines from the Cancer Cell Line Encyclopedia (CCLE) (Barretina et al., 2012). This signature is known to enrich in *KRAS* mutations and as expected, we see *KRAS* mutations enrichment in the cell lines with *KRAS* transcriptional activation. Strikingly, we find that mutations in *GNAS*, *PRKACA*, and *PDE4D* are also significantly enriched among these cell lines (Figure 11E). Of note, most *KRAS* mutant cells harbored only a single mutation within the G α s-PKA pathway. While mutations in *GNAS* are dominated by hotspot activating mutations, *PRKACA* harbors several less frequent hotspot activating mutations. Conversely *PDE4D* is often deleted in cancer (Chapter 1, Ramms, et al.). Together these data suggest that co-occurrence of mutation in *GNAS* and *KRAS* may be reflective of a broader association of G α s-PKA pathway activation in the context of activating *KRAS* mutations.

GNAS and KRAS drive tumor initiation in skin

Figure 12. Transgenic mouse model of *GNAS* and *KRAS* co-mutation. A) Left panel illustrates transgenes used in the breeding scheme. The tamoxifen-inducible Cre recombinase is under the control of the cytokeratin 14 promoter (cK14-CreERT2) in order to drive expression in the basal layer of the skin, which includes the stem cell compartment. Tissue-specific expression is conferred by Cre-mediated excision of the lox-STOP-lox controlling *Kras* G12D and rTA. *GNAS* R201C is regulated by the Tet-On system, requiring rTA and doxycycline. Right panel illustrates expressed genes upon tamoxifen (tam) and doxycycline (dox) induction. B) To induce transgene expression, mice were treated with tamoxifen locally on the back of the mouse for 5 consecutive days and maintained on doxycycline chow diet throughout the experiment. C) Images of mice of the four genotypes (Control, Tet-*GNAS* R201C, *Kras* G12D, and Tet-*GNAS* R201C/*Kras* G12D) 6 weeks after induction. D) Tumor growth curves and E) disease-free survival over the course of 6 weeks (n=8 mice per genotype). F) Representative cross sections of treated skin stained by hematoxylin and eosin staining from each of the four genotypes.

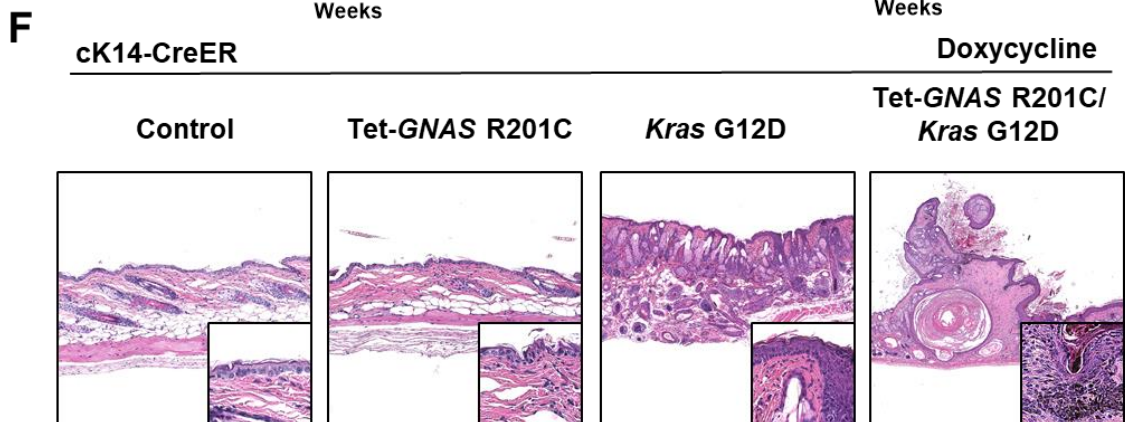
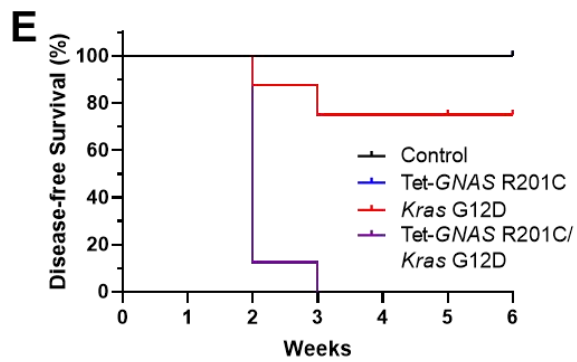
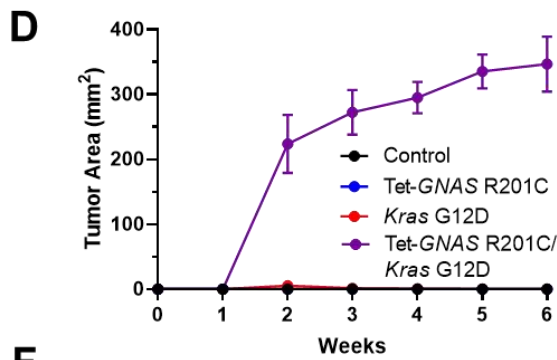
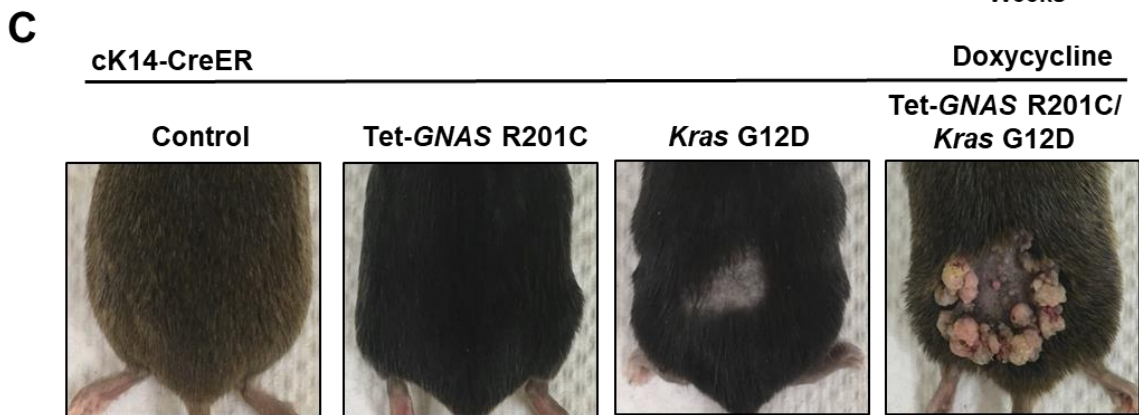
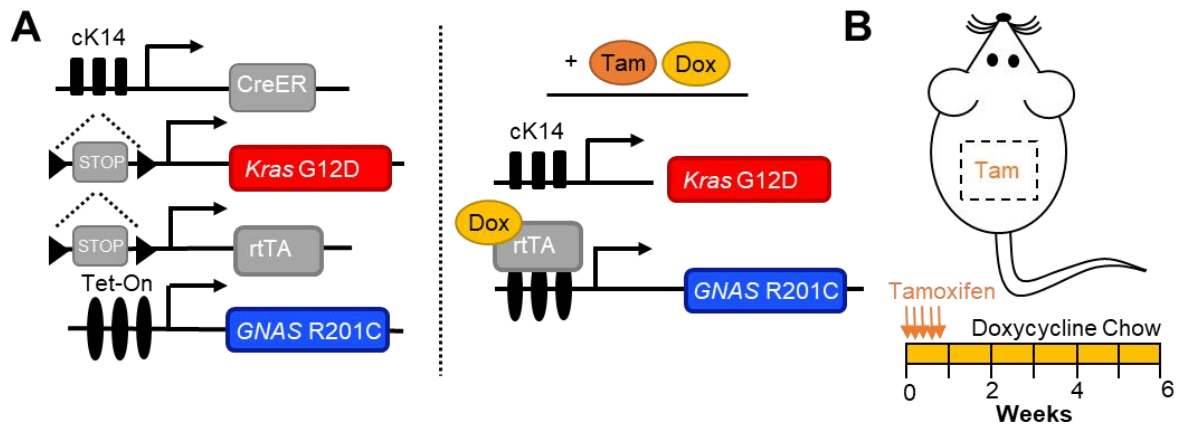

To test whether this co-occurrence of *GNAS* and *KRAS* mutation is functionally important, we developed a genetically engineered mouse model (GEM) using the skin as a model organ due to its ease of accessibility, and the well-established role of RAS in and mouse skin carcinogenesis (Lowry et al., 2016) and human squamous cell carcinomas (SCC) (Oberholzer et al., 2012). Previous studies by our group have also shown that expression of *GNAS* R201C in the mouse epidermis induces hair follicle terminal differentiation and formation of keratinized cysts. Ultimately this differentiation results in stem cell exhaustion and did not drive tumorigenesis (Iglesias-Bartolome et al., 2015). To target the epidermal stem cells in a temporally-controlled manner, we utilized mice expressing a tamoxifen inducible Cre recombinase under the control of the cytokeratin 14 promoter (cK14-CreERT2). cK14-CreERT2 mice were crossed with mice harboring the G12D point mutation in the endogenous *Kras* gene. The presence of an upstream lox-STOP-lox site blocks expression of the mutant in the absence of Cre (LSL-*Kras* G12D) to avoid any developmental effects during the breeding process (Jackson et al., 2001). In parallel, we also crossed cK14-CreERT2 mice with mice harboring *GNAS* R201C under the control of a tetracycline inducible promoter (Tet-*GNAS* R201C) as well the reverse tetracycline-controlled transactivator (rtTA) “linker” gene (LSL-rtTA-IRES eGFP). Together this genotype conferred inducible expression of *GNAS* R201C in the presence of Cre expression and doxycycline in the chow diet. Finally, cK14-CreERT2/LSL-*Kras* G12D and cK14-CreERT2/Tet-*GNAS* R201C/linker mice were crossed with each other to generate co-mutant mice as well as all appropriate littermate controls (Figure 12A). Of note, *Kras* G12D and *GNAS* R201C were maintained as heterozygotes throughout all breeding schemes to better model the gene dosage seen in patients.

Since cytokeratin 14 is expressed throughout the epidermis, including in the oral cavity, we chose to specifically induce transgene expression on the back of the mice. Solubilized tamoxifen was applied directly to the shaved back of mice for 5 consecutive days. On day 5, all mice were switched to doxycycline-containing chow diet for the remainder of the experiment

Figure 13. Chemical model of *GNAS-Ras*-induced carcinogenesis. A) Transgenic scheme for expression of *GNAS* R201C in the skin. Expression of rtTA was driven by the cytokeratin 5 promoter (cK5-rtTA) and induced in the presence of doxycycline. B) To induce *Ras* mutations in the presence of *GNAS* R201C mutation, mice were treated locally on the back once per week with DMBA while maintained on doxycycline chow diet. C) Images of the four treatment groups (control, Tet-*GNAS* R201C, DMBA, and Tet-*GNAS* R201C/DMBA) after 5 weeks on experiment. D) Tumor growth curves and E) disease-free survival plots during the course of 5 weeks (n=5 mice per treatment group). F) Cross sections of treated skin stained by hematoxylin and eosin staining from each of the four treatment groups.

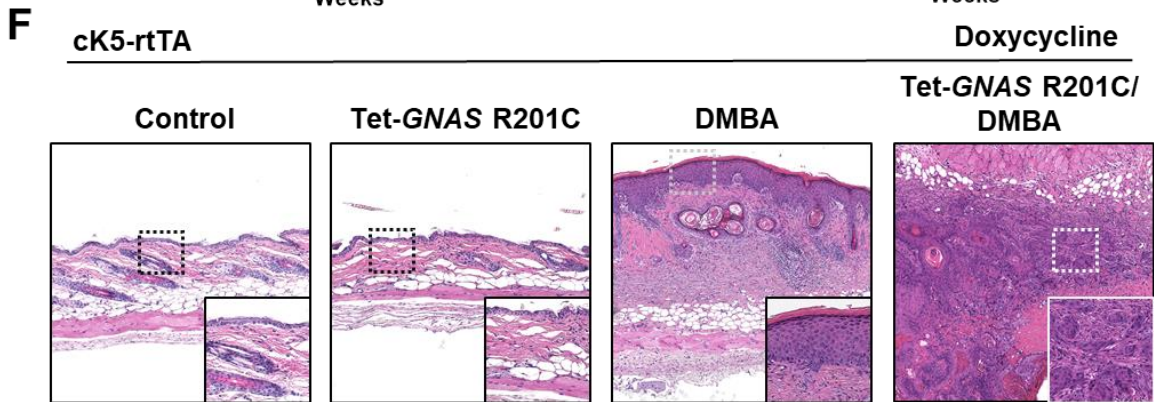
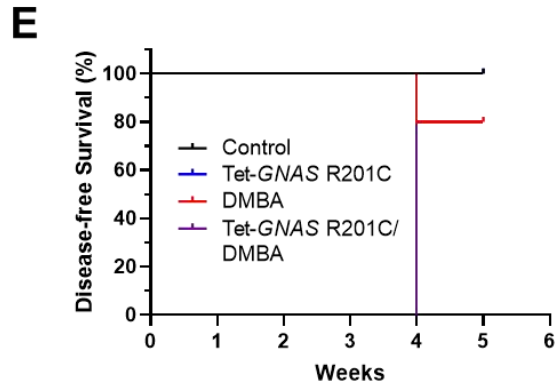
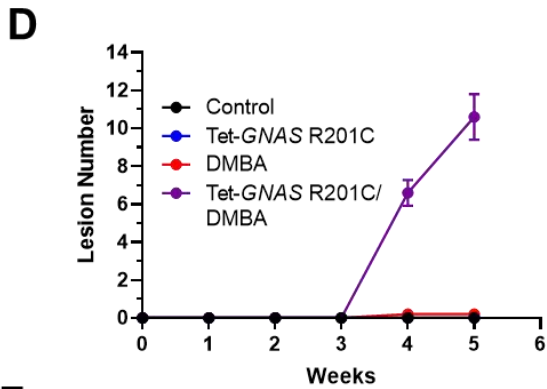
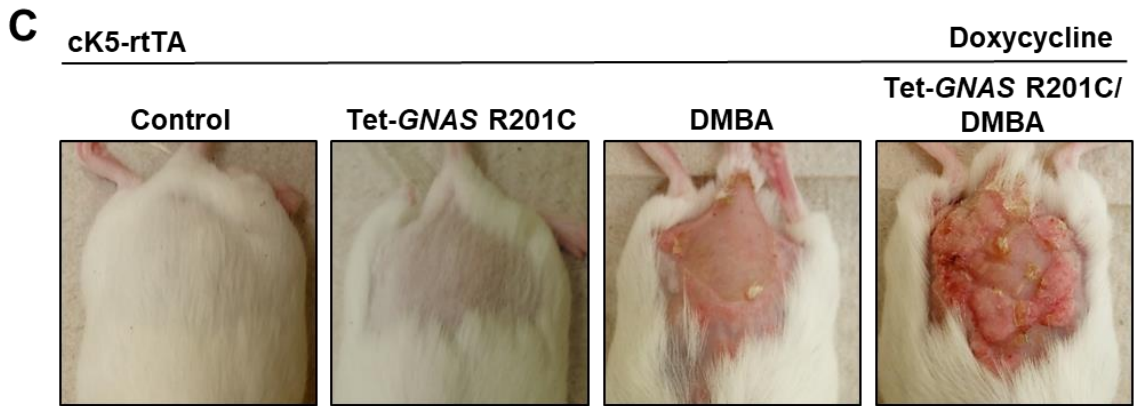
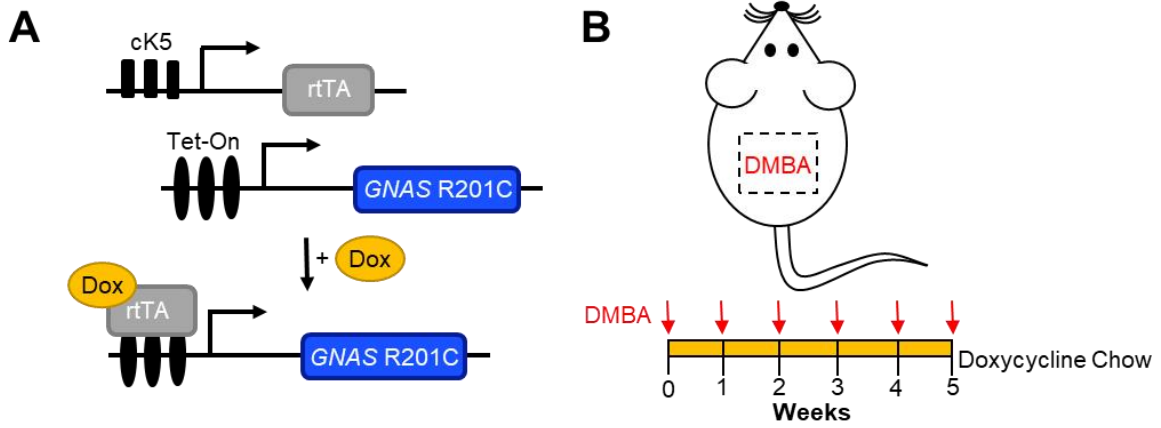

(Figure 12B) in each of four experimental groups: control, Tet-*GNAS* R201C, *Kras* G12D, and Tet-*GNAS* R201C/*Kras* G12D. As expected, control and Tet-*GNAS* R201C mice exhibited no apparent phenotype, while *Kras* G12D mice had mild hair loss (Figure 12C). Surprisingly, Tet-*GNAS* R201C/*Kras* G12D mice rapidly developed tumors beginning at two weeks (Figure 12D). Consistent with previous findings, Tet-*GNAS* R201C single mutant mice did not develop tumors even after 6 weeks. Of note, a few *Kras* G12D mice developed small lesions (<10mm³), but many of them spontaneously regressed (Figure 12E). Histological analysis revealed that *Kras* G12D mice exhibited mild hyperproliferation of the hair follicle stem cell population leading to the hair loss observed grossly. Tet-*GNAS* R201C/*Kras* G12D mice developed papillomas including some with cystic morphology (Figure 12F). The observed cystic morphology is consistent with the histology of other *GNAS* mutant mouse models we have reported previously (Ideno et al., 2018; Iglesias-Bartolome et al., 2015).

GNAS drives carcinogenesis in DMBA treated mice

Given the contribution of environmental carcinogens and other inflammatory factors to carcinogenesis in humans, we next developed a model of *GNAS* and *Ras* cooperation through chemical induction of *Ras* mutations with 7,12-Dimethylbenz[a]anthracene (DMBA). DMBA is a commonly used carcinogen that is well established to preferentially induce *Hras* mutation and less frequently *Kras* mutation (Nassar et al., 2015). DMBA is also commonly used in conjunction with a tumor promoter, like 12-O-Tetradecanoylphorbol-13-acetate (TPA), which activates protein kinase C (PKC) and induces inflammation, as a model of chemical carcinogenesis in the mouse (Abel et al., 2009). Adapting this model, we replaced the promoter step with transgenic expression of *GNAS* R201C. To simplify the transgenic scheme, we utilized a mouse constitutively expressing rtTA under the control of the cytokeratin 5 promoter (cK5-rtTA). cK5-rtTA mice were crossed with Tet-*GNAS* R201C mice, which express when doxycycline is present

(Figure 13A). Again, Tet-*GNAS* R201C mice were maintained as heterozygotes throughout the breeding scheme.

To test the ability of *GNAS* and *Ras* to cooperate, *GNAS* expression was induced by switching all mice to doxycycline chow diet in each of four experimental groups: control, Tet-*GNAS* R201C, DMBA, and Tet-*GNAS* R201C/DMBA. Mice were treated once per week locally on the shaved back with DMBA or vehicle control and monitored (Figure 13B). Consistent with the fully transgenic model, Tet-*GNAS* R201C/DMBA mice rapidly developed lesions as early as four weeks, accumulating in number with time (Figure 13D and E). Control and Tet-*GNAS* R201C mice had no apparent phenotype while DMBA treated mice developed some redness and irritation at the application site. Of note, a few DMBA mice developed a single small lesion. Histologically, control and Tet-*GNAS* R201C appeared largely normal while DMBA treated mice had mild hyperproliferation and inflammation. Dramatically, Tet-*GNAS* R201C/DMBA mice developed many papillomas with regions of squamous cell carcinoma (SCC) (Figure 13F). Interestingly, the histology of Tet-*GNAS* R201C/DMBA mice was similar to the SCC induced by the classical DMBA/TPA model.

Organoid model of GNAS and KRAS co-mutation

In light of the robust evidence of *GNAS* and *Ras* cooperation in the skin, we aimed to transfer our model to a more physiologically relevant tissue context. Further we aimed to generate a model that facilitated ease of study *in vitro* while still maintaining the tissue context. Given the prevalence of *GNAS* and *KRAS* co-mutation in both the small and large intestines (Figure 11C) and optimized protocols for intestinal organoid culture (Sato et al., 2009) we next developed an intestinal organoid model of *GNAS* and *KRAS* co-mutation. Specifically, we chose to target transgene expression to the intestinal tract using the tamoxifen-inducible CDX2 Cre (CDX2-CreERT2). CDX2 has been shown to target intestinal stem cells as well as several more differentiation cell populations within intestinal crypts (Feng et al., 2013). Using a breeding scheme

Figure 14. Intestinal organoid model of *GNAS* and *KRAS* co-mutation. A) Transgenic scheme for expression of *GNAS* R201C and *Kras* G12D mutants in the intestine. CDX2 drives Cre-mediated removal of the lox-STOP-lox elements and expression of *Kras* G12D and rtTA (linker). *GNAS* R201C is under the control of a tetracycline responsive element (Tet-On) that responds to doxycycline in the presence of rtTA. B) Images of organoid cultures generated from CDX2-CreERT2/linker mice with either Tet-*GNAS* R201C, LSL-*Kras* G12D, or both transgenes. Cultures were derived without transgene induction. C) Validation of transgene expression in CDX2/Tet-*GNAS* R201C/linker. Cultures were treated with 4-OH tamoxifen and doxycycline or vehicle for 48 hours. *Gas* and the Glu-Glu-(EE) tag mark expression of *GNAS* R201C and GFP marks expression of linker. D) Validation of *GNAS* R201C activity as measured by an increase in pPKA substrate signaling 48 hours after transgene induction. E) Images of CDX2/Tet-*GNAS* R201C/linker organoids show morphological changes after 24 hour treatment with 4-OH tamoxifen and doxycycline. F) Profiling of cell population markers by RT-qPCR in CDX2/Tet-*GNAS* R201C/linker organoids after 24 and 48 hours induction. *Lgr5* (*Lgr5*) and villin 1 (*Vil1*) mark stem cells, lysozyme (*Lyz1*) marks paneth cells, mucin 2 (*Muc2*) marks goblet cells, chromogranin A (*ChgA*) marks enteroendocrine cells, intestinal alkaline phosphatase (*Alpi*) marks enterocytes, and *GNAS* detects transgene expression. F) Profiling of mucin expression 48 hours after transgene induction. For E) and F) * $p < 0.05$ using an unpaired t-test relative to control for each gene. For all images, scale bar is 100 μ m.

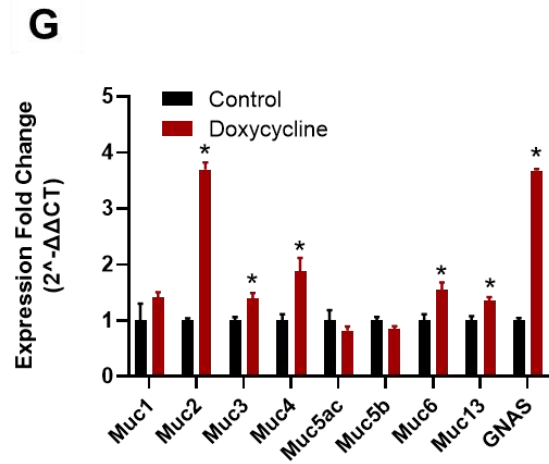
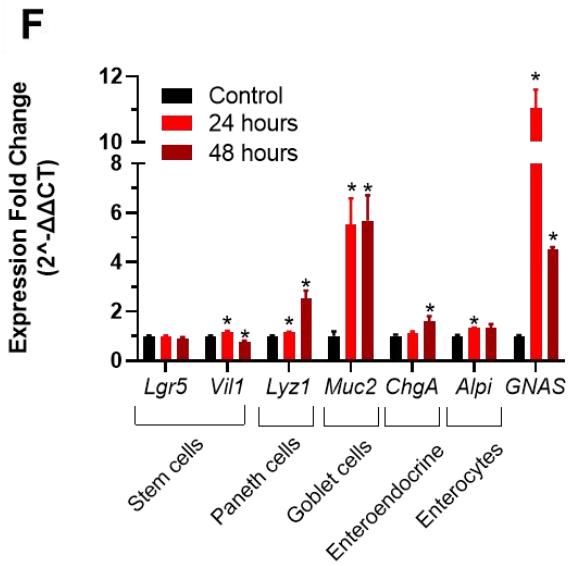
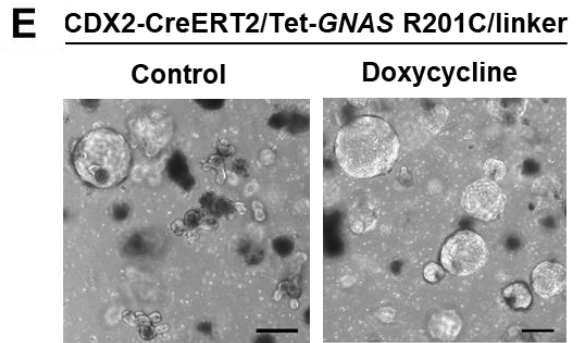
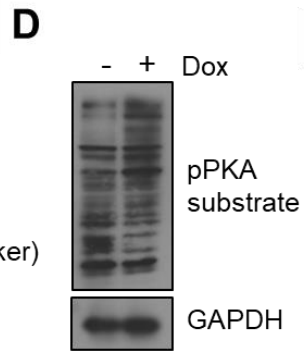
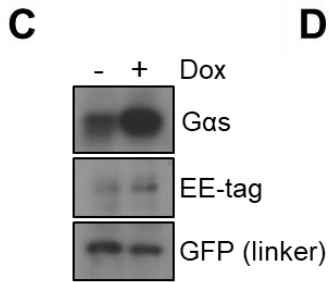
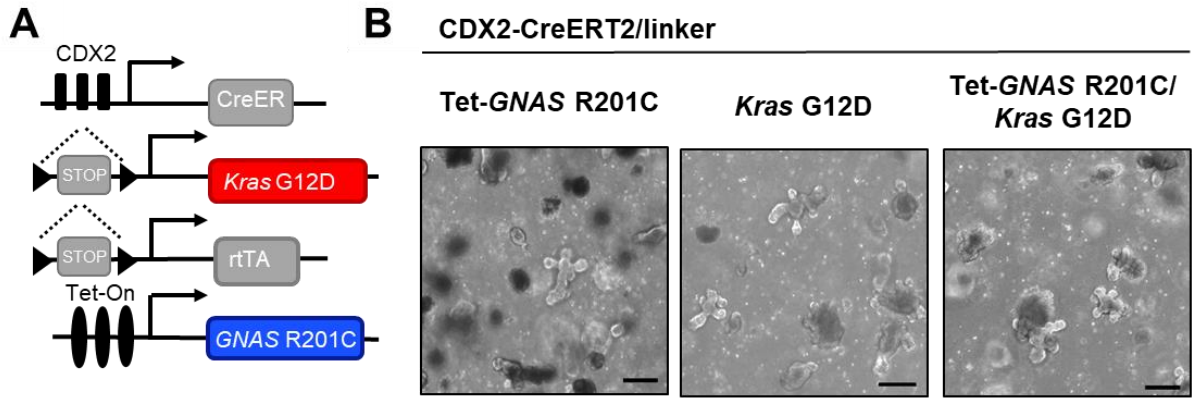

similar to that used previously (Fig 11A), we generated CDX2-CreERT2/LSL-KRAS G12D mice as well as CDX2-CreERT2/Tet-GNAS R201C/linker mice. These two genotypes were crossed with each other to yield co-mutants as well as single mutant littermate controls (Figure 14A).

In order to develop stable organoid lines, intestines were isolated fresh from post-weaning mice of the appropriate genotype. Of note, all transgenes remained off throughout the isolation protocol. Briefly, a small portion of the distal small intestine was used to generate the initial organoid lines. Crypts were isolated using EDTA dissociation and after extensive washing, crypts were plated in matrigel domes and cultured in conditioned media optimized for growth of intestinal stem cells. After several passages, stable organoid lines were established with budding “mini-gut” morphology (Figure 14B)(Sato et al., 2009). Organoid lines were derived from CDX2-CreERT2/linker mice harboring the Tet-*GNAS* R201C and/or the LSL-*Kras* G12D transgene(s).

As a proof of principle, we chose to characterize the CDX2-CreERT2/Tet-*GNAS* R201C/linker organoids further. To test for expression and functionality of transgenic components, we blotted for *Gas* and EE tag as markers of *GNAS* R201C expression, GFP as a marker of linker expression, and pPKA substrate as a measure of functionality. Indeed, we confirmed induction of *Gas* expression with stable expression of linker (Figure 14C). Transgene expression resulted in a robust increase in pPKA substrate signal (Figure 14D). Unexpectedly, we observed a dramatic change in morphology in response to *GNAS* R201C expression. *GNAS* R201C expressing organoids rapidly shifted to a cystic morphology in less than 24 hours (Figure 14E). Expression of *GNAS* R201C has been shown to alter normal differentiation patterns in other tissue contexts(Ideno et al., 2018; Iglesias-Bartolome et al., 2015; Zhao et al., 2018). Since the cell populations present in intestinal organoid cultures has been extensively characterized(Barker, 2014; Clevers, 2013), we checked markers of each cell population by quantitative reverse transcription PCR (RT-qPCR) in response to *GNAS* R201C expression. Interestingly, we find that, *GNAS* R201C robustly induced mucin 2 (*Muc2*) expression which is a marker of goblet cells

(Figure 14F). Goblet cells are secretory cells that produce mucin which is required to protect the intestinal epithelium(Birchenough et al., 2015). There was also a smaller increase in lysozyme (*Lyz1*) which is a marker of paneth cells. Paneth cells are also a secretory cell type, but unlike goblet cells, they reside near the base of the crypt and support maintenance of the stem cell population(Gassler, 2017). Finally, to understand the global effects of *GNAS* R201C expression on mucin expression, we tested a panel of mucin genes by RT-qPCR. Interestingly, we find that *GNAS* R201C upregulated most mucin genes, with *Muc2* showing that largest increase after 48 hours (Figure 14G). Together these findings highlight that expression of the *GNAS* R201C mutation in small intestinal organoids drives a cystic morphology that is driven by expansion of the secretory cell populations such as goblet and paneth cells.

Discussion

In the current age of precision and genomic medicine, it is increasingly evident that cancer is a complex disease. Difficulty in translating pre-clinical results into clinical successes has highlighted the dire need for better mouse models that can capture this complexity, including contributions from genetic, environmental, inflammatory, and immunological factors. Here we focus on the interaction of two genes: *GNAS*, with mutation in around 4% of all tumors(O'Hayre et al., 2013), and the well-known *KRAS* mutation, present in 20% of all tumors(Prior et al., 2020). *GNAS*, which encodes the *Gas* subunit of G protein coupled receptors (GPCRs), functions upstream of other key pathway components including regulators of cAMP, like adenylyl cyclase and phosphodiesterase, and downstream of the cAMP-responsive kinase, protein kinase A (PKA). Our analysis reveals that additional mutations in the *Gas*-PKA pathway also co-occur with *KRAS* mutations. Specifically, these mutations include activating mutations in the PKA catalytic subunit α (encoded by *PRKACA*) and deletions of *PDE4D*(Chapter 1, Ramms, et al.). Together these findings suggest that activation of the *Gas*-PKA pathway may cooperate with activating *KRAS* mutations in cancer initiation or progression.

In order to better understand the genetic interaction of the Gas-PKA pathway and *KRAS* observed in patients, we developed three genetically engineered mouse models. Using the skin for the initial optimization of our model, we took two approaches to better interrogate this cooperative interaction. We demonstrated that expression of *GNAS* and *Kras* activating mutations rapidly and robustly induced tumorigenesis, while single mutation was insufficient to drive tumorigenesis. Furthermore, we recapitulated this result by replacing the *Kras* transgene with carcinogen-induced *Ras* mutations caused by DMBA. The ability of *GNAS* and *Ras* to cooperate in the skin is particularly exciting as skin chemical carcinogenesis models are well characterized in their step-wise progression from hyperplasia to papilloma and eventually to squamous cell carcinoma (SCC) over several months (Abel et al., 2009). Here, our chemical model developed SCC in a matter of 6 weeks, far quicker than the 20 weeks that is normally required (Abel et al., 2009). Furthermore, our models generated papillomas as quickly as 2- 4 weeks in the transgenic tumorigenesis and chemical carcinogenesis models, respectively. By comparison, papilloma development typically occurs around 10 weeks in the standard DMBA/TPA model (Abel et al., 2009). Together these results highlight that *GNAS* contributes to tumor initiation, a role that has already been defined for *KRAS* (Waters and Der, 2018). As discussed in Chapter 1, we have previously suggested that *GNAS* may contribute to cancer initiation based on the presence of mutations in precursor lesions as well as the action of other pathway contributors, such as COX-2 which participates in the production of pathway ligands. COX-2, in particular, is recognized as an early biomarker of inflammation in many cancer types, including in colorectal cancer where its overexpression even precedes *KRAS* mutation (Markowitz and Bertagnolli, 2009).

While the mechanisms by which *GNAS* and *KRAS* co-mutation contribute to cancer initiation still remains unknown, skin chemical carcinogenesis models can again provide valuable insight into potential mechanisms of cooperation. In the standard DMBA/TPA model, DMBA treatment induces initial mutations while TPA induces inflammation and cell turnover, allowing additional genomic alterations to accumulate during the progression to SCC (Abel et al., 2009).

Recent efforts to profile these genomic alterations confirmed the prevalence of *Ras* mutations (90% of SCCs), but also highlighted recurrent loss of function mutations in tumor suppressors like *Trp53*, *Myh9*, and *Notch1*. Furthermore these SCCs were also characterized by profound amplification of chromosomes 6 and 15, harboring *Kras* and *Myc* oncogenes, respectively(Nassar et al., 2015). In our model, *GNAS* R201C efficiently replaces TPA and facilitates rapid development of SCC in the absence of major genomic alterations (data not shown). Given similar phenotypic outcomes, it is plausible that activation of *GNAS* replaces the functional effects of these genomic alterations. For instance, *KRAS* and *MYC* are well-known to cooperate in cancer through multiple mechanisms, potentiating *MYC*-driven transcriptional programs that promote cancer cell growth and survival(Land et al., 1983; Mahauad-Fernandez and Felsher, 2020). Recent work by our group revealed that the Gas-PKA pathway can promote *MYC* RNA stability and subsequent elevation of *MYC* protein levels(Chapter 3, Ramms, et al.). This raises the exciting possibility that *GNAS-KRAS* co-mutation may function by facilitating *KRAS-MYC* cooperativity, which is under current investigation. While more detailed mechanistic studies are certainly required to dissect true cause and effect in these early initiation events, the transgenic and chemical mouse models described here provide the ideal platform to begin to understand these complex polygenetic interactions.

Finally, since skin is not a tissue context that commonly harbors mutations in *GNAS* and *KRAS* in human cancers, we also generated an intestinal organoid model of co-mutation. Building on the established culture protocols and our inducible transgenic construction, this model maintains the relevant biological tissue context while bringing the technique *in vitro* to facilitate molecular understanding of signaling interactions and regulatory gene programs. Here we provide a proof of principle that *GNAS* R201C expression in intestinal organoids recapitulates known biology and patient phenotypes, including cystic morphology and mucinous disease characteristic of pancreatic, appendiceal, and colorectal mucinous neoplasms(Amato et al., 2014; Hata et al., 2020; Lee et al., 2014; Molin et al., 2013; Nishikawa et al., 2013; Yamada et al., 2012).

Given our initial work here, this model is also primed for adaptation to other tissue contexts, including future application as a syngenic implantable model of pseudomyxoma peritonei (PMP). PMP is a rare condition characterized by *GNAS-KRAS* co-mutation and highly mucinous cancer that metastasizes from the appendix to the peritoneum (Alakus et al., 2014; Ang et al., 2018). Taking advantage of the ability of our organoid model to robustly induce mucin production *in vitro*, there is a unique opportunity to exploit this feature to better understand its effect *in vivo*. Certainly there are several technical hurdles and considerations to this type of model, most notably, the ability of intestinal organoids to implant in the peritoneum of immune competent animals. Previous work has demonstrated that peritoneal implantation of human PMP is possible in immunodeficient mice (Kuracha et al., 2016; Mavanur et al., 2010). However, recent work has also demonstrated that even triple mutant colon organoids with *KRAS* G12D, knockout of *TP53*, and *APC* have limited implantation success rate (Drost et al., 2015). Despite these challenges, this model certainly holds promise by combining the flexibility of *in vitro* culture with the complexity of *in vivo* growth.

In summary, our studies make important progress towards understanding the role of the Gas-PKA pathway in cooperation with *KRAS* and provide several model platforms for the further characterization of this interaction. Ultimately, we hope that these mouse models can one day be utilized to screen *GNAS* mutant cancers for unique drug sensitivities.

Acknowledgements

Chapter 2, specifically the development of skin cancer mouse models, is currently being prepared for publication. Ramms, D.J., Callejas-Valera, J.L., Amornphimoltham, P., Molinolo, A.A., Tamayo, P., and Gutkind, J.S. (2021). G protein signaling primes Ras-driven tumorigenesis. The dissertation author was the primary investigator and author of this material. Additionally, the intestinal organoid mouse models discussed in Chapter 2 were generated in collaboration with Dr. Hervé Tiriach and Dr. Andrew Lowy at the University of California San Diego. Ramms, D.J.,

Tiriac, H., Lowy, A.M., and Gutkind, J.S. (2021) Chapter 2, Organoid model of *GNAS* and *KRAS* co-mutation.

I would like to thank additional members of the Lowy lab, including Dr. Randall French and Dr. Tatiana Hurtado De Mendoza for their many helpful discussions and technical advice regarding human and organoid cultures. I would also like to thank Dr. Eduardo Villar and Dr. Prashant Bommi at MD Anderson Cancer Center for their help preparing conditioned media and optimizing organoid culture. I would like to acknowledge the Moores Cancer Center Biorepository and Tissue and Technology Shared Resource for assistance in acquiring patient tissues for organoid generation and model optimization. I would also like to thank Dr. Zhiyong Wang and Dr. Robert Saddawi-Konefka for their help in mouse model development. I would like to thank Dr. William Kim for his help exploring the *GNAS-KRAS* genetic interactions. Finally, I would like to thank Dr. Olivier Harismendy, Joseph Steward, and Daniela Nachmanson for their helping with related sequencing experiments in mouse models.

Methods

Analysis of mutational co-occurrence

Mutational co-occurrence analysis was performed using cBioPortal(Cerami et al., 2012; Gao et al., 2013) and the MSK-IMPACT pancancer dataset(Zehir et al., 2017). Mutations that co-occurred with *KRAS* mutations were queried based on all mutations for *KRAS*. Mutations that co-occurred with *GNAS* mutations were queried on all mutations for *GNAS*. All other alternations (fusions, copy number changes) were excluded. Log ratio represents \log_2 ratio of the percentage of patients with mutation divided by the percentage of patients without mutation ($\log_2(\% \text{ mutant}/\% \text{ non-mutant})$). One-sided Fisher exact test statistics were performed using the log ratio to determine a p-value. The Benjamini–Hochberg procedure was then used to correct for multiple comparisons and statistical significance was using set a q-value <0.05. All statistical analysis

was downloaded directly from cBioPortal. Cancer tissue types represented were queried based on co-mutation of *GNAS* and *KRAS*.

Analysis of mutational enrichment in cancer cell lines

Enrichment of *KRAS* mutations with *GNAS*-PKA pathway mutations was performed using cancer cell line data from the Cancer Cell Line encyclopedia (CCLE)(Barretina et al., 2012). The *KRAS* C3 Activation signature was previously described and the computational platform REVEALER was used to quantify enrichment of pathway mutations(Kim et al., 2017; Kim et al., 2016).

Generation of mouse models

All animal studies were performed according to protocols approved by the Institutional Animal Care and Use Committee (IACUC) of the University of California San Diego. Mice expressing the reverse tetracycline transactivator (rtTA) under the control of the cytokeratin 5 (cK5-rtTA) were previously described(Vitale-Cross et al., 2004). Mice expressing *GNAS* R201C under the control of tetracycline responsive element (Tet-*GNAS* R201C) were previously described(Iglesias-Bartolome et al., 2015). The cK5-rtTA Tet-*GNAS* R201C mice were bred on a FVB/N background and Tet-*GNAS* R201C mice were always maintained as heterozygotes. Mice harboring the tamoxifen-inducible Cre recombinase under the control of the cytokeratin 14 promoter (cK14-CreER) were purchased from The Jackson Laboratory [JAX STOCK 005107, Tg(KRT14-cre/ERT)20Efu/JK14Cre](Vasioukhin et al., 1999). Heterozygous mice expressing *Kras* G12D were obtained also obtained from The Jackson Laboratory [JAX STOCK 008179, B6.129S4-Krastm4Tyj/J](Jackson et al., 2001). To link the Cre recombinase and Tet-On inducible systems, mice with a lox-STOP-lox controlled rtTA (termed linker mice) were purchased from The Jackson Laboratory [JAX STOCK 005670, B6.Cg-Gt(ROSA)26Sortm1(rtTA, EGFP)Nagy/J](Belteki et al., 2005). For intestine-specific expression, mice with the CDX2-driven

tamoxifen inducible Cre (CDX2-CreERT2) were purchased from The Jackson Laboratory [JAX STOCK 022390, B6.Cg-Tg(CDX2-Cre/ERT2)752Erf/J](Feng et al., 2013). Unless otherwise noted, all mice were of mixed background and post-weaning males and females were utilized for experiments. Animal genotypes were confirmed by PCR of tail DNA.

In vivo tumorigenesis assay

Under isoflurane anesthesia, a 24mm² region of the mouse back was shaved. Drug or vehicle was applied locally to a 15mm² area of the shaved region. Specifically, cK5-rtTA/Tet-*GNAS* 201C mice were treated with either acetone or 7,12-Dimethylbenz[a]anthracene (DMBA) weekly for 5 weeks. DMBA was prepared 100µg in 200µl acetone (Sigma, D3254). For cK14-CreER/Tet-*GNAS* R201C/*Kras* G12D linker mice, 100µL of 10mg/ml tamoxifen (Sigma, T5648) in DMSO was applied locally for 5 consecutive days. During the experiment, mice were switch to doxycycline chow diet containing 6000ppm doxycycline(Bio-Serv). Tumor development was monitored weekly under isoflurane anesthesia. Tissues were formalin fixed and paraffin embedded for histological analysis. All embedding and staining was performed by the Tissue Technology Shared Resource (TTSR) at the University of California San Diego.

Organoid culture and in vitro transgene induction

Intestinal organoids were prepared from the small intestine of transgenic mice from the CDX2-CreERT2/Tet-*GNAS* R201C/*Kras* G12D/linker colony. Crypts were isolated as previously described(Sato and Clevers, 2013). Briefly, a small section of intestine was isolated fresh and washed extensively with PBS. Crypts were dissociated by incubating with EDTA followed by vigorous shaking. Villi and crypt fractions were pooled and filtered through a 70µm strainer. Crypts were centrifuged and resuspended in DMEM/F12+++ (see below) before resuspending in matrigel (Corning, 356231) and plating 100µl per dome in a pre-warmed 12-well plate. Matrigel was allowed to solidify at 37°C before adding 1ml of complete media. Complete media consisted of

DMEM/F12+++ (see below) with 10% R-spondin1 conditioned media, 10% Noggin, 1X B27 (Invitrogen, 17504-044), 1X N2 (Invitrogen, 17502-048), 1mM N-acetyl cysteine (Sigma, A9165-5G), and 50ng/ml mouse EGF (Biolegend, 585606). R-spondin1 and Noggin conditioned media was prepared according to Tuveson Laboratory protocols described previously (Baker et al., 2017). Conditioned media lines were generously provided by Dr. Eduardo Villar at MD Anderson. DMEM/F12+++ consisted of Advanced DMEM F12 (Invitrogen, 12634-010), 10mM HEPES (ThermoFisher, 15630-080), GlutaMax (Invitrogen, 35050-061), antibiotic cocktail (Sigma, A5955), Primocin (Invitrogen, ant-pm-2).

Organoid cultures were split as needed to prevent accumulation of dead cells ~1:5 every 4 days once line was established. To split, media was aspirated and organoids thoroughly resuspended in 1ml Cell Recovery Solution (CRS) (Corning, 354253) to dissociate dead cells from budding crypts. Organoid solution was transferred to a 15ml conical tube and incubated on ice for 10 minutes with occasional mixing. Solution was centrifuged at 200 x g for 5 minutes and supernatant aspirated. Pellet was resuspended in DMEM/F12+++ before centrifuging again at 200 x g for 5 minutes. Media was aspirated and pellet was resuspended in the appropriate volume of matrigel (100µl per well) and plated on a pre-warmed 12-well plate. After the matrigel solidified at 37°C, 1 ml of complete media was overlaid. Organoids were resuspended in CryoStor (Sigma, CS10) for long term storage in liquid nitrogen. To induce transgene expression *in vitro*, 10µM 4-hydroxy-tamoxifen (Sigma, 579002) in DMSO and 100ng/µl doxycycline (Sigma, D9891-5G) in water was added to the media for the duration of the experiment.

Western blotting of murine organoids

For western blot analysis, one 100µL matrigel dome of organoids was used for each sample. To prepare for lysis, media was removed and 1ml of CRS was used to dislodge the dome before transferring to a 1.5ml tube on ice. Organoids were vortexed for 10 seconds and then incubated on ice for 10 minutes, inverting occasionally. Organoids were then vortexed again for

10 seconds and centrifuged at 1000 x g for 5 minutes. After aspirating CRS, pellet was resuspended in 1ml of fresh CRS and vortexed. Organoids were incubated on ice for another 10 minutes with occasional inversion. After the incubation, organoids were vortexed for a final time and centrifuged at 1000 x g for 5 minutes. CRS was completely removed and pellet resuspended in ice cold RIPA buffer (50mM Tris-HCl pH 6.8, 150mM NaCl, 1% NP-40, 0.5% sodium deoxycholate, 0.1% SDS) buffer with a cocktail of protease and phosphatase inhibitors (Bimake, B14001, B15001-A/B). Lysates were normalized for protein concentration and denatured with boiling in Laemelli's samples buffer. Samples were then separated on 10% acrylamide gels and transferred to PVDF membranes (Immobilon, IPVH304F0). Membranes were blocked and all subsequent antibody incubations occurred in 2% BSA in TBST. Primary antibodies against Gas (Calbiochem, 371732, 1:1000), Glu-glu tag (Cell Signaling Technology, 2448, 1:1000), GFP (Cell Signaling Technologies, 2956, 1:1000), pPKA Substrate pRXXS/T (Cell Signaling Technology, 9621, 1:1000), and GAPDH (Cell Signaling Technology, 2118, 1:10000) were used at listed dilutions. Goat anti-rabbit secondary antibody were used at 1:40,000 (Southern Biotech 4010-05).

RNA isolation and RT-qPCR from organoids

Transgene induction was performed 24 to 48 hours in advance with one 12-well dome per sample. To isolate RNA from organoids, media was aspirated and 500µl trizol (Qiagen, 79306) was added to each dome and homogenized well. Sample were flash frozen on dry ice and stored at -80°C if needed. 120µl of chloroform (Fisher, C298-500) was added to thawed organoids in trizol and vortexed for 15 seconds. Samples were incubated at room temperature for 3 minutes and then centrifuged at 12,000 x g for 15 minutes at 4°C. Upper aqueous phase was transferred to a new 1.5ml tube and 1.5 volumes of 100% ethanol (Sigma, E7023) added. Sample was mixed well by pipetting and then transfer onto RNeasy columns (Qiagen, 74104). Remainder of extraction was performed according to manufacture protocols. RNA concentration was normalized and converted to cDNA using SuperScript VILO (Invitrogen, 11754-050). Fast SYBR

Green (Applied Bio Systems, 4385612) was used to measure RNA levels of the indicated genes by RT-qPCR (Applied Bio Systems, QuantStudio 6 Flex). Primer pairs are available in Table S6. CT values were normalized to GAPDH and expressed as \log_2 fold change ($-\Delta\Delta CT$).

CHAPTER 3

Protein-protein interaction map reveals a PKA regulated RNA binding protein network.

Abstract

Protein kinase A (PKA) orchestrates complex, interconnected signaling networks that regulate diverse biological processes. Its unique tetrameric structure facilitates its coordination of specific interactions, modulated by spatial-temporal constraints and discrete activation states of the cell. While there is an immense body of literature supporting PKA's signaling activities, there is still much that remains unknown, particularly the role of PKA in human diseases. For instance, many monogenetic diseases are caused by point mutations in the PKA holoenzyme, but the precise PKA downstream targets mediating these pathophysiological processes are still poorly understood. Here we leverage the biochemical features of disease-causing mutations to construct a dynamic PKA interactome, specifically focusing on the active state of the kinase. Unexpectedly, we identify a large number of novel PKA interactors that participate in key cellular and organismal functions, including RNA binding proteins, ribosomal components, mitochondrial components, and proteins involved in metabolism, cytoskeletal organization, and DNA replication and repair regulation. Further characterization of the novel interactions with RNA binding protein involving HuR and IMP-1/3 reveals that PKA promotes RNA stabilization and the corresponding translation of target genes. Furthermore, by understanding these posttranscriptional regulatory networks, we identify BRD4 as a promising therapeutic target for PKA pathway-driven cancers.

Introduction

Protein kinase A (PKA) signaling serves as a central regulatory hub for countless biological processes. From control of specific metabolic enzyme activities to coordination of global cell differentiation programs, PKA regulates complex and highly interconnected signaling networks. Consisting of two regulatory subunits and two catalytic subunits, PKA exists as a holoenzyme whose stability is controlled by the binding of the second messenger cAMP. Upon binding of cAMP to the regulatory subunits, the catalytic subunits are released and then free to phosphorylate their substrates (Kim et al., 2007). In order to regulate its activation, PKA resides in

discrete microdomains throughout the cell, enabling contacts with a diverse array of proteins. Many of these microdomains are specifically coordinated by A kinase anchoring proteins (AKAPs) that bind regulatory subunits and other interactors such as PKA substrates and pathway regulators(Langeberg and Scott, 2015; Torres-Quesada et al., 2017). Further PKA is also able to integrate signaling from many upstream inputs that result in cAMP production, including activation of G protein coupled receptors (GPCRs) and the Gas G protein. With this complexity, it is not surprising that dysregulation of PKA signaling can cause a large number of monogenetic diseases, largely displaying endocrine phenotypes and developmental alterations. Recent efforts by our group highlighted that many of these mutations are also present in a variety of cancers tissues(Chapter 1, Ramms, et al.). However, given the diversity of PKA's roles in normal physiology, pinpointing specific contributions of PKA to cancer phenotypes has been challenging.

Identification of PKA interacting proteins has been a successful strategy to understand the diversity of the PKA signaling actions. Previously attempts to capture PKA's physical interactions have used multiple approaches including the use of cAMP analogs(Aye et al., 2009; Bachmann et al., 2016; Luo et al., 2009) or tagged proteins as baits(Coles et al., 2020). Similarly, other groups have turned to reporter(Röck et al., 2015a; Röck et al., 2015b) and yeast-two hybrid screens(Carlson et al., 2003). Unfortunately, despite the diverse approaches, these results have largely confirmed known contacts due to the high-affinity interactions with holoenzyme components and the utilization of methods that favor the inactive state of PKA catalytic subunit as part of its holoenzyme. In order to stabilize the active state of the kinase, we utilized disease-causing mutations of both catalytic and regulatory subunits to alter holoenzyme stability. Using affinity purification mass spectrometry (AP-MS), we then directly compared the interactions of mutant baits with the corresponding wild-type baits, an approach that our group recently pioneered in head and neck cancer(Swaney, et al., 2021). By manipulating PKA holoenzyme dynamics, we favor interactors of the active kinase and the catalytic subunit. Unexpectedly, we uncover an abundance of RNA binding protein contacts, including complexes known to coordinate

posttranscriptional RNA stability. Mechanistic analysis revealed that PKA coordinates stabilization of target RNAs, such as *MYC* and *BRD4*, through the *N*⁶-methyladenosine (m6A) modification of RNA. Ultimately, this regulatory role of PKA suggests that *BRD4* represents a promising therapeutic target in PKA pathway-driven cancers.

Results

Selection and validation of disease-based PKA baits

In order to capture the dynamic interactions of PKA, we selected disease-causing mutations that have known biochemical impacts on holoenzyme stability and compared them to their wild-type counterparts. First, we focused on the PKA catalytic subunit α (PKA C α or C α) as the most well-studied and ubiquitously expressed catalytic subunit. We selected the W197R mutation that was first identified in Cushing's disease, but is also recurrently mutated in cancer (Chapter 1, Ramms, et al.). This mutation resides at the interface of the regulatory and catalytic subunits and drives constitutive activity due to loss of regulatory subunit contacts (Walker et al., 2019), hence resulting in cAMP-independent kinase activity but without affecting structural features involved in substrate recognition. Secondly, we similarly focused on the most well-studied and ubiquitously expressed regulatory subunit, PKA R1 α or R1 α (Chapter 1, Ramms, et al.). Here we selected the R335K mutation that is found in diseases that are characterized by loss of PKA activity, such as acrodysostosis (Silve et al., 2012). The R335K mutation resides in the second of two cAMP binding domains found in R1 α . The mutation inhibits the binding of cAMP and ultimately results in incomplete dissociation of the holoenzyme in response to cAMP and retention of catalytic subunit binding (Bruystens et al., 2016). In order to identify interactions specific to our wild-type (WT) and mutant (MUT) baits, we cloned each into a doxycycline-inducible 3xFLAG-tagging lentiviral construct (Figure 15A). Baits were then transduced into HEK293 cells (referred to as "parental") and HEK293 cells engineered to ubiquitously express the hotspot activating mutation *GNAS* R201C (referred to as "pathway active"). As the most common

Figure 15. Generation of PKA baits. A) Overall workflow for detection of PKA protein-protein interactions (PPIs). Wild-type (WT) and mutant (MUT) PKA C α and R1 α were cloned into a FLAG-tagging, doxycycline-inducible lentiviral backbone. Bait expression was under the control of a tetracycline responsive element (TRE) and reverse tetracycline-controlled transactivator (rtTA) was also expressed from the plasmid. Lentivirus was then produced for each bait and used to transduce parental and pathway active HEK293 cells. To detect PPIs, doxycycline was used to induce bait expression. Bait proteins along with interactors were affinity purified with the FLAG-tag and identified with mass spectrometry (AP-MS). B) Validation of PKA C α and C) PKA R1 α bait expression and function by western blotting. D-E) Validation of bait expression using a cAMP responsive element (CRE)-luciferase reporter assay. Statistics were determined by an unpaired t-test, ***p<0.001, ns: not significant. F) Immunofluorescent staining for FLAG in PKA C α and G) PKA R1 α WT and MUT lines to determine the location of baits in cell.

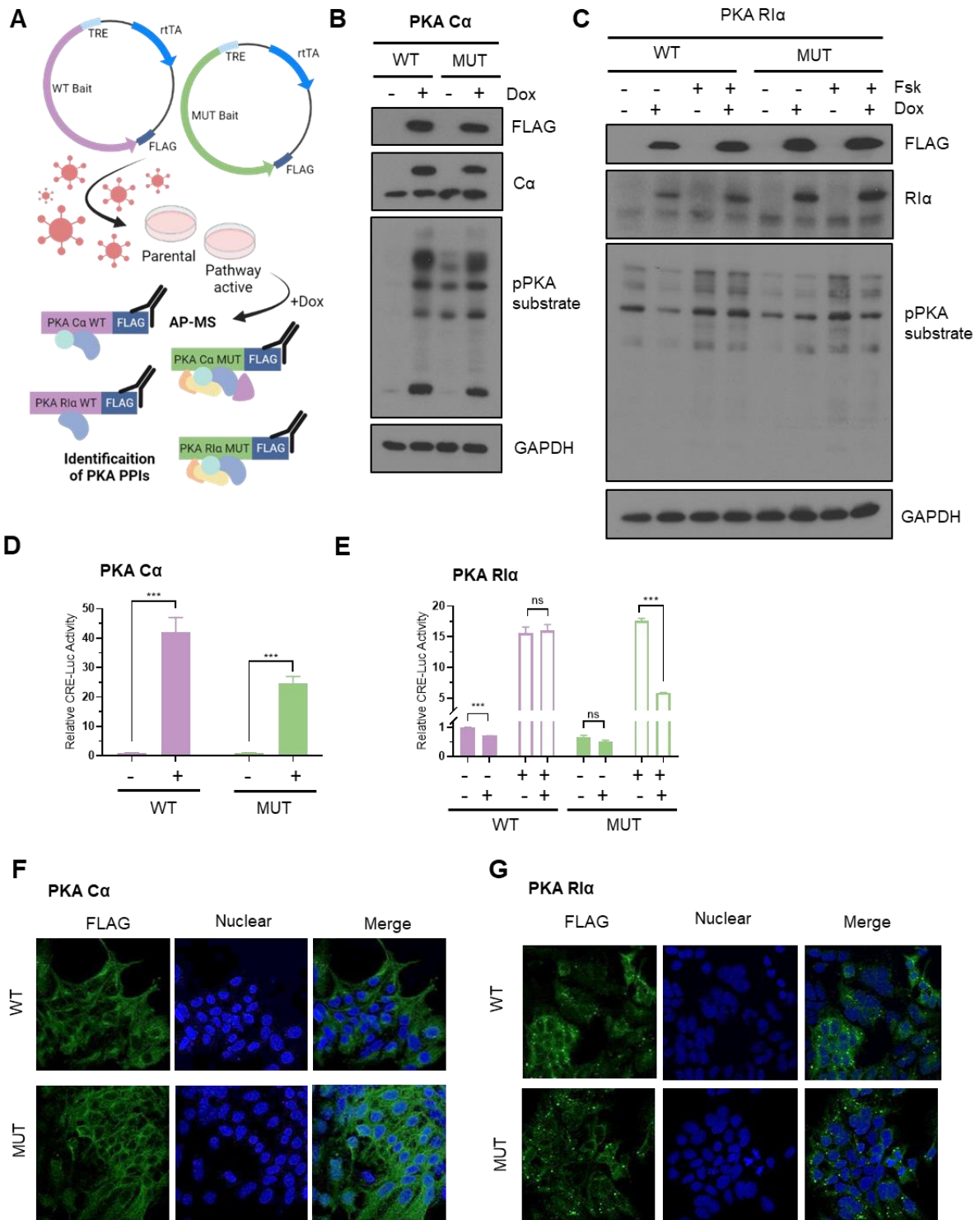

upstream PKA pathway mutation in cancer(O'Hayre et al., 2013; Wu et al., 2019), the *GNAS* mutant cell context was used to model contacts of PKA when the pathway is overactive. Of note, the PKA pathway can also be constitutively activated by upstream GPCRs due to elevated ligand levels, or receptor overexpression or mutation(Dorsam and Gutkind, 2007; Raimondi et al., 2019). Next, to confirm the functionality of each bait we measured established readouts of PKA activity, including phosphorylation of PKA substrates and activation of a cAMP response element (CRE) transcriptional reporter (Figure 15B-E). We also confirmed the localization of all WT and MUT baits were consistent with each other and published reports(Sample et al., 2012; Skalhegg and Tasken, 2000; Zhang et al., 2020). $\text{C}\alpha$ displayed primarily a cytoplasmic localization, while $\text{R}\alpha$ was also cytoplasmic with the presence of discrete puncta (Figure 15F-G). Finally, the 3xFLAG tag was used for purification of interacting proteins and identification with mass spectrometry (AP-MS) (Figure 15A).

Generation of a dynamic PKA interaction map

First, we visualized the dynamics of the $\text{C}\alpha$ interactome by comparing wild-type (WT) versus mutant (MUT) baits as well as categorizing prey species by broad biological functions (Figure 16A). As expected, PKA holoenzyme contacts dominated the $\text{C}\alpha$ WT interactome, including contacts with other catalytic subunits (PRKACB, PRKACG), regulatory subunits (PRKAR1A, PRKAR2A, PRKAR1B, PRKAR2B), and several AKAP molecules (AKAP1, AKAP2, AKAP5, AKAP7, AKAP9, AKAP11). Consistent with the known biochemistry of the W197R mutation as an active mutation that is dissociated from regulatory subunit binding, PKA holoenzyme contacts that were present in the WT bait were completely lost in the MUT bait (Table S7). Dramatically, $\text{C}\alpha$ MUT acquired a diversity of contacts, including many interactions with RNA binding proteins, ribosomal components, mitochondrial components, and proteins involved in metabolism, cytoskeletal organization, and DNA replication and repair regulation. Of note, many of the same functional groups were also represented in $\text{C}\alpha$ WT, but to a much lesser extent

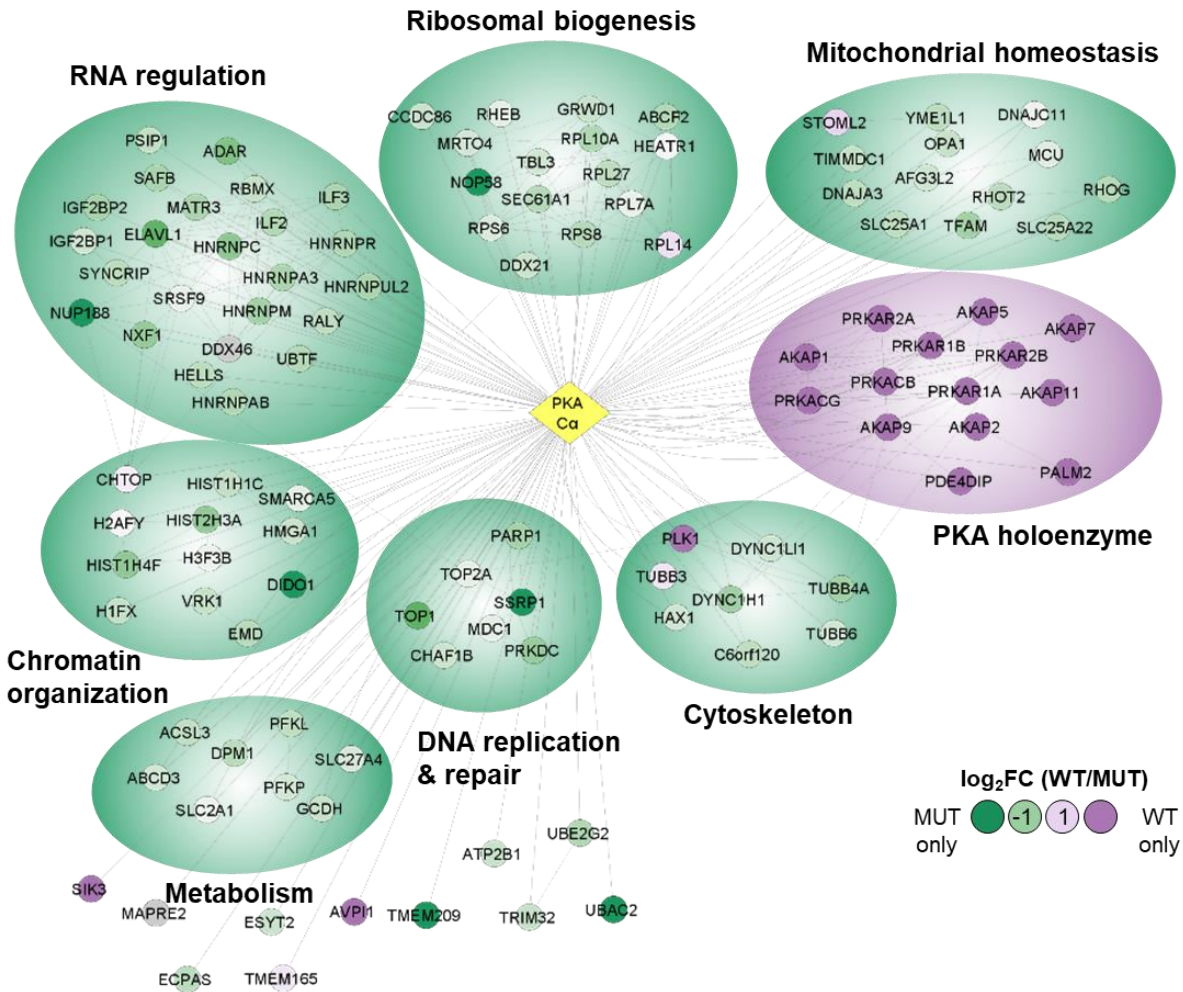

Figure 16. PKA α interaction network. A) All wild-type (WT) and mutant (MUT) PKA α interacting prey with BFDR ≤ 0.2 . Interactors are colored by \log_2 fold change (WT/MUT average spectral counts) with WT-specific interactors in dark purple and MUT-specific interactors in dark green. Those interactions only found in the pathway active cell context are colored gray. Interactors are organized by functional groups and network edges between prey species reflect high confidence interactions (STRING score >0.9). Edges connecting to the central bait (yellow) reflect interactions detected in this study.

(Figure 16A). Interestingly, the interactomes of both $C\alpha$ baits were relatively consistent across the parental and pathway active cell contexts (Table S7).

Next we analyzed the $R1\alpha$ interactome by again comparing the WT and MUT baits (Figure 17A). Unlike the $C\alpha$ mutation which is constitutively active, $R1\alpha$ R335K functions as a dominant negative by retaining contacts with the catalytic subunit even in the presence of cAMP. In line with these binding dynamics, we found that the comparison of WT and MUT bait interactors in the pathway active context (HEK293 *GNAS* R201C) was particularly informative (Table S7). As expected, the $R1\alpha$ WT interactome consisted almost entirely of holoenzyme contacts, again including endogenous catalytic subunits (PRKACB), regulatory subunits (PRKAR1A, PRKAR1B), and AKAPs (AKAP11, C2orf88, GPR161). Interesting, $R1\alpha$ WT picked up several interactors not seen with $C\alpha$ WT, such as C2orf88 or smAKAP which is a unique AKAP known to reside at the plasma membrane (Burgers et al., 2012) and GPR161 which is a GPCR that contains an AKAP binding motif and functions in the cilia (Bachmann et al., 2016).

While $R1\alpha$ MUT also retained many regulatory and catalytic subunit contacts, impressively, it recapitulated almost all of the functional groups present in the $C\alpha$ MUT interactome and even many of the same interactors. Specifically, despite their different cell signaling contexts and bait proteins, $C\alpha$ MUT (parental) and $R1\alpha$ MUT (pathway active) baits shared 32 common interactors, accounting for 22% of all interactors in these conditions (Figure 18A). By comparison, the $C\alpha$ WT bait across the parental and pathway active cells contexts shared 65 interactors (46% of interacting prey) and the $R1\alpha$ WT bait shared 11 interactors (36% of interacting prey) across cell contexts, highlighting the robustness of these shared interactions (Table S8). Given the lack of regulatory subunit contacts observed with $C\alpha$ MUT, it is likely that interactions with endogenous catalytic subunits pulled down with $R1\alpha$ MUT are driving these overlapping results among $C\alpha$ and $R1\alpha$ MUT baits. Further, these results provide independent validation of the unique interactors

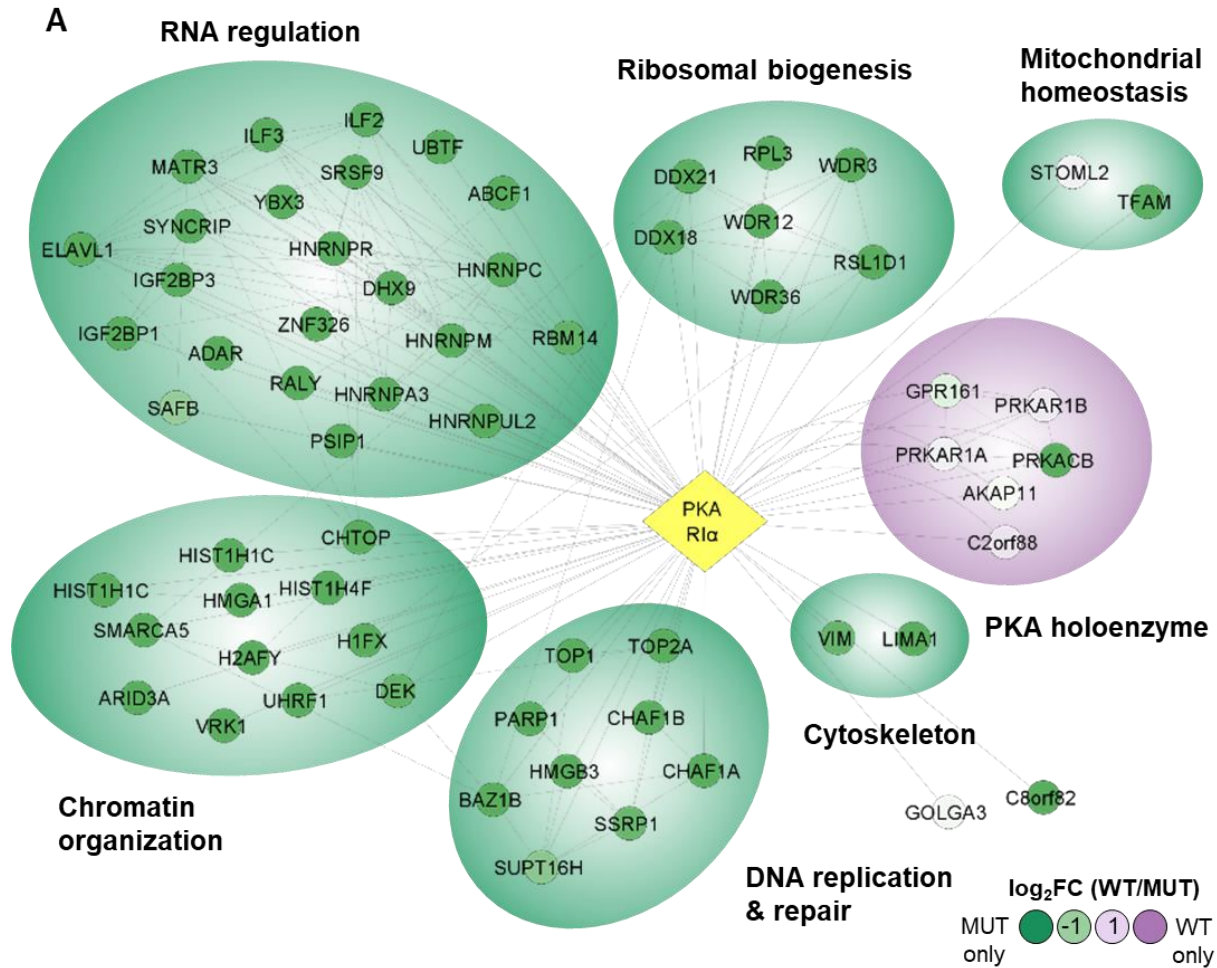

Figure 17. PKA R1 α interaction network. A) All wild-type (WT) and mutant (MUT) PKA R1 α interacting prey with BFDR ≤ 0.2 . Interactors are colored by log₂ fold change (WT/MUT average spectral counts) for each prey detected in the pathway active cell context. WT-specific interactors are in dark purple and MUT-specific interactors are in dark green. Those interactions only found in the parental cell context are colored gray. Interactors are organized by functional groups and network edges between prey species reflect high confidence interactions (STRING score >0.9). Edges connecting to the central bait (yellow) reflect interactions detected in this study.

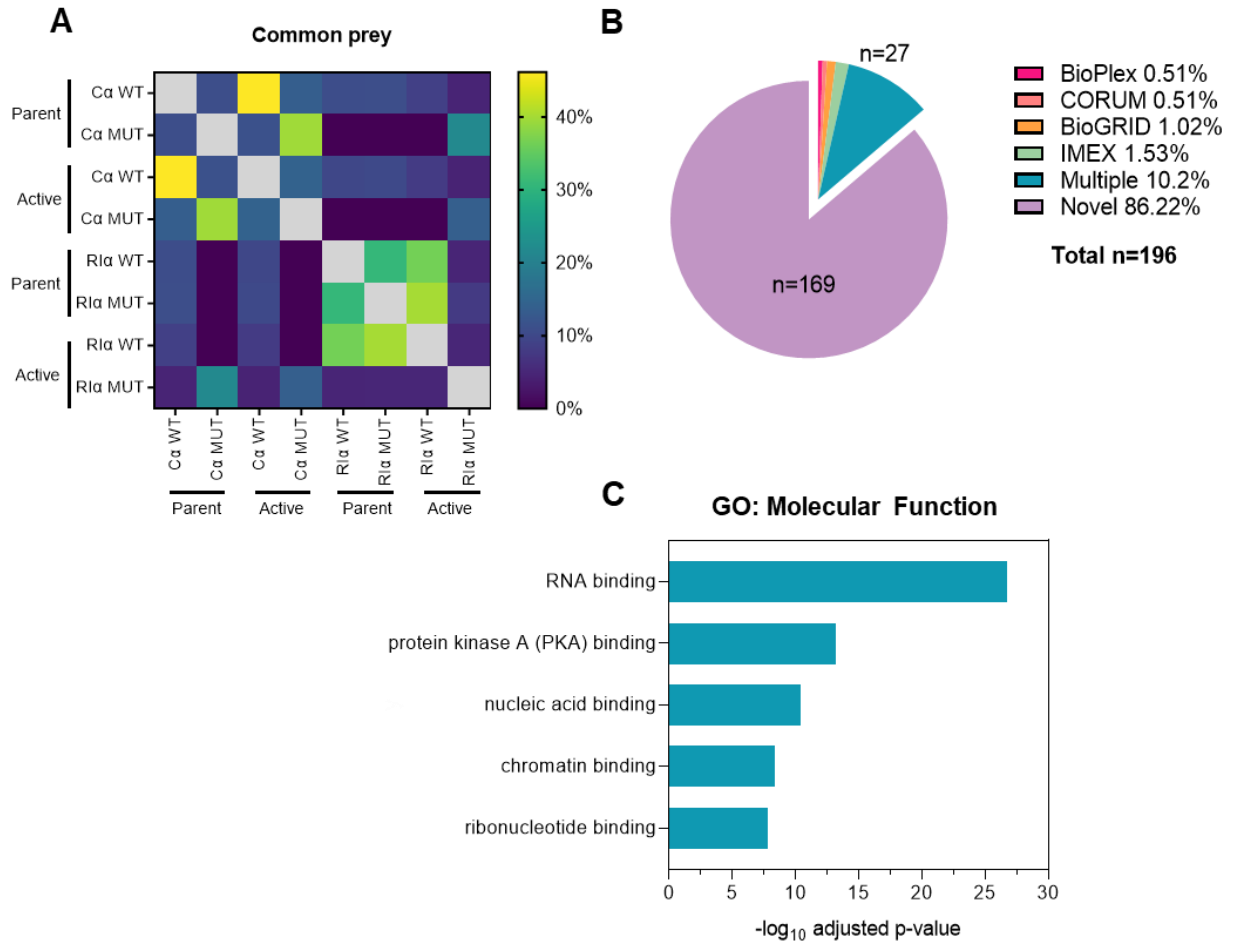

Figure 18. Network quantification. A) Quantification of common prey among all PKA baits in both cell contexts. Heatmap displays percentage of prey species shared by a given pair. Parent = HEK293 and Active = HEK293 *GNAS* R201C. B) Quantification of novel protein-protein interactions (PPIs) against publically available databases. Percentages of common or novel PPIs are displayed. A total of 196 PPIs were considered (BFDR \leq 0.2). C) Gene ontology (GO) molecular function enrichment analysis of the entire PKA network.

present in both C α MUT and R1 α MUT, suggesting that these interactions are physiological and not simply artifacts or mutation-specific interactions. Strikingly, when we compare the interactions detected in our PKA interactome to those documented in five publically available databases (BioPlex, STRING, CORUM, BioGRID, IMEX), we find that over 86% of our interactions are novel and not previously reported (Figure 18B). Finally, to better understand the novel interactors we discovered, we performed enrichment analysis of the complete PKA interactome. Interestingly, our analysis revealed that RNA binding was the dominant feature of the network even above PKA binding (Figure 18C). Other notable molecular functions include nucleic acid binding, chromatin binding, and ribonucleotide binding.

RNA stability factors dominate RNA binding interactions

Given the prevalence of RNA binding protein (RBP) interactions present in our network, we performed enrichment analysis on the RNA binding functional group to gain a better understanding of which biological processes were represented by these RBPs. Interestingly, we found that two of the highest scoring processes involved regulation of mRNA stability and posttranscriptional gene expression regulation (Figure 19A). As shown by the network edges, many of these proteins are known to interact with each other (Figure 19B). Specifically, known complexes involving RNA stabilizers like HuR (*ELAVL1*), and readers of posttranslational RNA modification and RNA regulatory regions, such as the IMP family (*IGF2BP1*, *IGF2BP2*, *IGF2BP3*), are present (CORUM ID:6838)(Giurgiu et al., 2019; Huang et al., 2018). We chose to focus on HuR because it was a high confidence interactor of both C α MUT and R1 α MUT baits (BFDR ≤ 0.2), and a low confidence interactor with C α WT (Figure 19C). Furthermore, HuR expression on the RNA level was strongly correlated with the levels of C α (*PRKACA*) and R1 α (*PRKAR1A*) in cancer cell lines (Figure 19D-E). Of note, IMP family members shared similar patterns of bait

Figure 19. Validation of interactions with HuR and IMPs. A) Gene ontology (GO) biological process enrichment analysis of the RNA binding subnetwork identified in Figure 16A and Figure 17A. B) RNA binding subnetwork. RNA binding proteins (RBPs) involved in RNA stability are outlined in blue. C) Comparison of spectral counts for PKA C α baits in the parental context and PKA R1 α baits in the pathway active context. D) Correlation of *PRKACA* and D) *PRKAR1A* RNA expression levels with *ELAVL1* (HuR) expression in cancer cell lines. Statistics were determined with an unpaired t-test, *** $p < 0.001$. F) Validation of interactions between PKA and HuR by immunoprecipitation. Input protein levels are represented in the left panel while immunoprecipitated interactions are shown on the right. G) Immunofluorescent staining of HuR and FLAG-tagged PKA C α WT in parental cells.

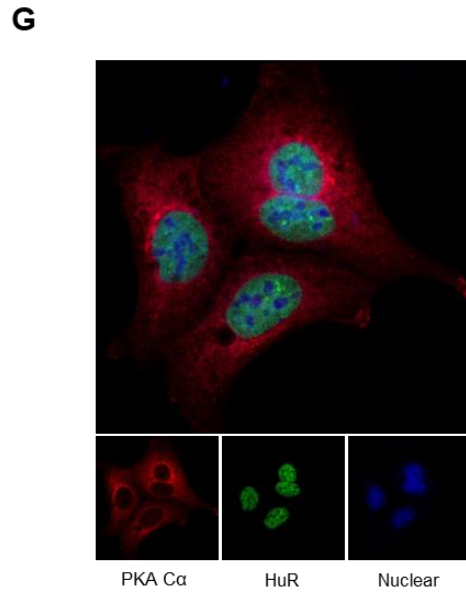
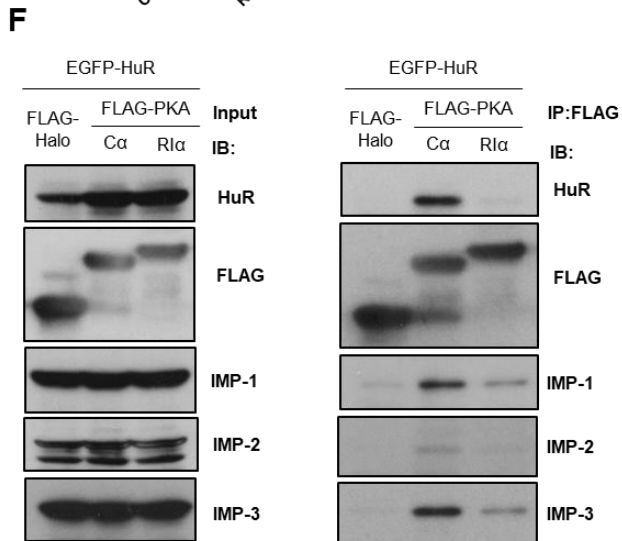
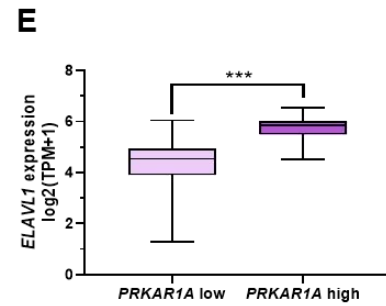
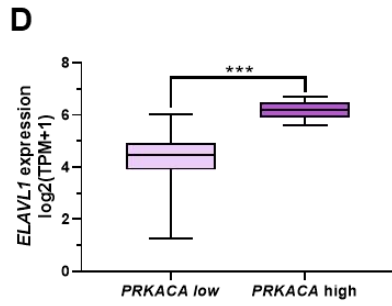
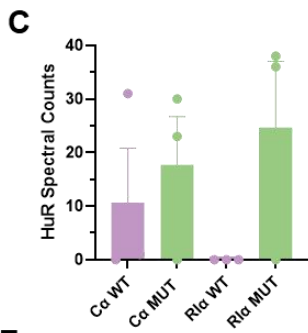
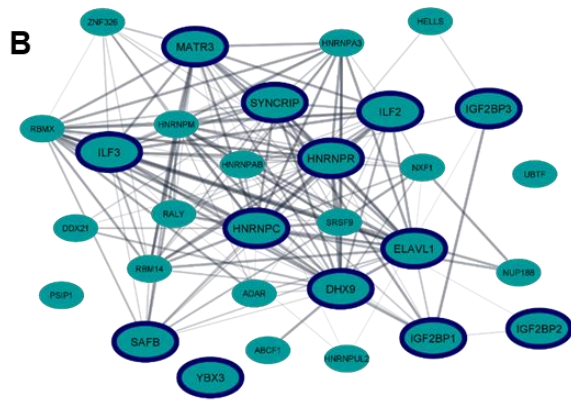
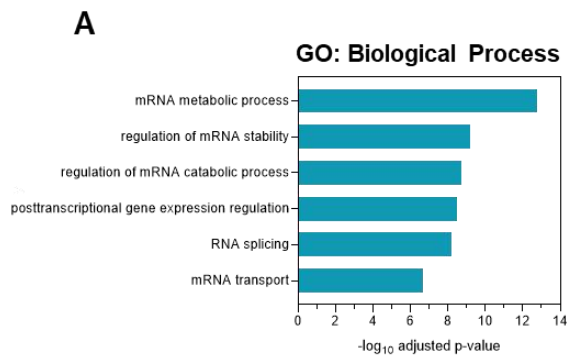

binding, but with the exception of IMP-3, their expression was not strongly correlated with PKA expression (Figure S1A-B).

To first validate these interactions, we co-expressed HuR with either FLAG-tagged C α WT, RI α WT, or FLAG-tagged control (HaloTag). Consistent with our AP-MS data, we found a strong interaction of C α WT and HuR, but little interaction with RI α WT (Figure 19F). Furthermore, endogenous IMP-1 and IMP-3 strongly immunoprecipitated with C α WT and HuR, while IMP-2 was only weakly detected. These data suggest again that these interactions are not mutation-specific interaction of C α , but rather mediated by the wild-type C α and perhaps enhanced upon dissociation of regulatory subunit contacts. To determine the cellular location of the HuR/C α interaction, we performed immunofluorescence in parental cells. HuR displayed strong nuclear staining, while PKA C α was primarily present in the cytoplasm with strong perinuclear staining consistent with previous literature (Figure 19G)(Fan and Steitz, 1998; Hand and Jungmann, 1989; Kuettel et al., 1985). Interestingly, both HuR and PKA are known to shuttle between the cytoplasm and nucleus, suggesting that their interaction could occur in both compartments or perhaps, PKA may even regulate shuttling as is the case for the RNA processing factor PTPB (also known as hnRNP I)(Xie et al., 2003), as well as transcription factors like CREB(Hagiwara et al., 1993) and ID1(Nishiyama et al., 2007). IMP family members on the other hand are known to reside in the cytoplasm, with perinuclear enrichment, but their role in nucleus is controversial(Bell et al., 2013)

PKA activity facilitates stabilization of target m6A RNAs

From the moment an RNA is transcribed and throughout the remainder of its life time, RNAs are coated with RBPs, facilitating RNA maturation, translocation, half-life, and eventually translation(Gebauer et al., 2021; Lukong et al., 2008). Multiple RBPs with diverse roles are capable of binding to the same RNA. For instance, AUF1 and HuR both known to bind to the same regulatory regions on RNA, but AUF1 promotes degradation, while HuR promotes stabilization(Abdelmohsen, 2012). Ultimately the fate of the RNA depends on the competition

between these different binding partners(García-Mauriño et al., 2017). Recently, HuR has been described as a co-factor working in conjunction with the IMPs, a family of N^6 -methyladenosine readers(Huang et al., 2018). N^6 -methyladenosine (m6A) is the most common reversible RNA modification. It is responsible for mediating specific RBP interactions which ultimately determine the fate of the RNA. The processes can include RNA stabilization or decay, translocation, and translation(He et al., 2019). Interestingly, we find that components of the m6A machinery are strongly correlated with PKA expression, including the catalytic components of the methyltransferase (*METTL3*, *METTL14*) as well as an eraser, *FTO*, suggesting a potential interplay between PKA activity and m6A modification (Figure 20A). The IMPs have been shown to preferentially bind RNAs with m6A modifications located in the 3' untranslated region (UTR) to facilitate RNA stabilization(Conway et al., 2016; Huang et al., 2018). *MYC*, in particular, is known to be a target RNA stabilized by IMP-1(Han and Choe, 2020; Huang et al., 2018; Weidensdorfer et al., 2009). Given the global nature of this type of posttranscriptional RNA regulation, we aimed to identify other RNAs that may be regulated in this way and determine the role of PKA in this process. To do this we cross-referenced published databases of m6A-sequencing(Dominissini et al., 2012; Meyer et al., 2012) with enhanced crosslinking and immunoprecipitation (eCLIP) datasets(Huang et al., 2018; Van Nostrand et al., 2020) that identified RNAs directly bound by each of the IMP family members (Figure 20B). From these data we compiled a candidate list of m6A RNAs bound by IMPs and selected a panel of RNAs relevant to cancer (Table S9). To determine if PKA plays a role in their stability, we screened each gene by RT-qPCR in response to inhibitors of PKA activity (Figure 20C). We utilized two different classes of PKA inhibitors, first a competitive ATP-analog that inhibits the catalytic subunit of PKA and secondly, a competitive cAMP-analog that inhibits the regulatory subunit of PKA, preventing holoenzyme dissociation. As a control we used a specific inhibitor of EPAC, another effector activated by cAMP, which is not expected to influence RNA stability. For this experiment, we selected the colorectal cancer cell

Figure 20. PKA promotes *N*⁶-methyladenosine (m6A) RNA stabilization. A) Correlation of *PRKACA* expression level with m6A writers (*METTL3* and *METTL14*) as well as eraser (*FTO*) in cancer cell lines. Statistics were determined by an unpaired t-test, $p^{***}<0.001$. B) Workflow for generation of candidate list of m6A RNAs bound by IMP family of m6A readers. Results from published m6A sequencing (m6A-seq) and enhanced crosslinking and immunoprecipitation (eCLIP) were cross-referenced to generate a list of candidate m6A RNAs bound by IMPs (Table S9). List was manually curated for cancer relevant genes and screened by RT-qPCR for regulation by PKA. C) SKCO1 cells were treated with PKA inhibitors H89 and Rp-cAMPs or off-target control (EPAC inhibitor, ESI-9) for 2 hours. Expression of a panel of target RNA was determined by RT-qPCR. Target RNAs are annotated according to the location of m6A modification. D) Time course of forskolin/IBMX (Fsk) stimulation for *BRD4* and *MYC* expression in SKCO1 cells. E) RNA stability assay for *BRD4* and *MYC*. SKCO1 cells were treated with actinomycin D (ActD) for the indicated time and level of RNA quantified. Statistics were determined by an unpaired t-test, $p^{*}<0.005$ in C-E. F) Target RNA levels after siRNA knockdown of indicated RNA binding proteins or PKA α . Statistics were determined by a one-way ANOVA with multiple comparisons, $p^{*}<0.005$ G) Confirmation of siRNA knockdown on the protein level.

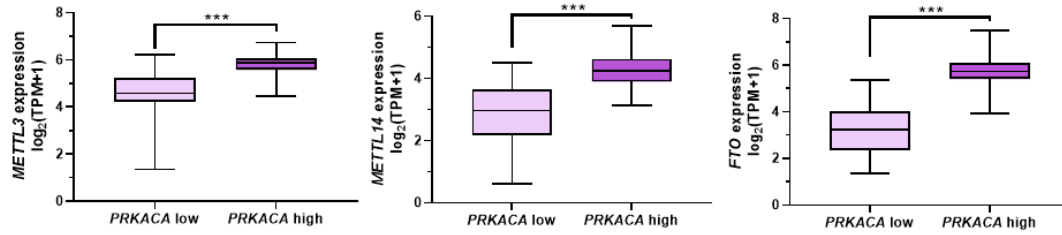
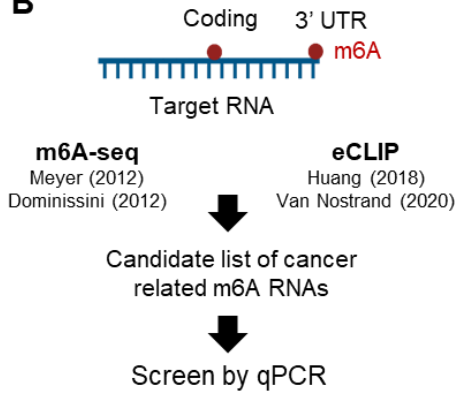
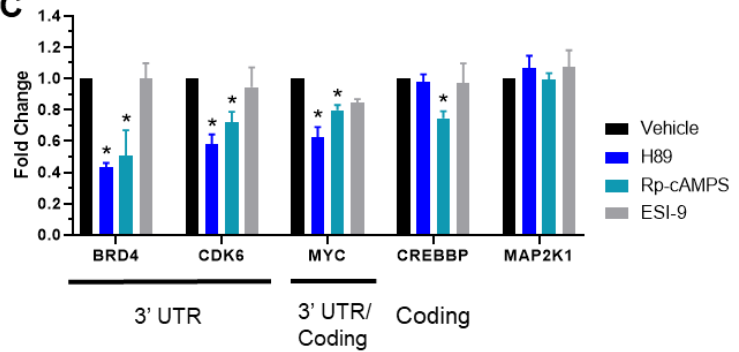
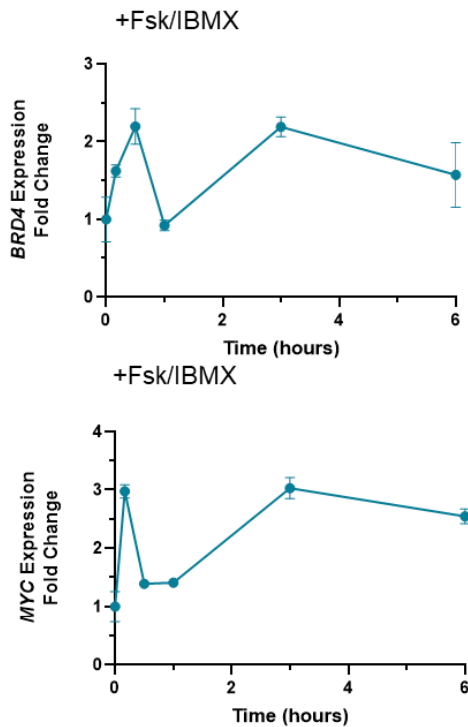
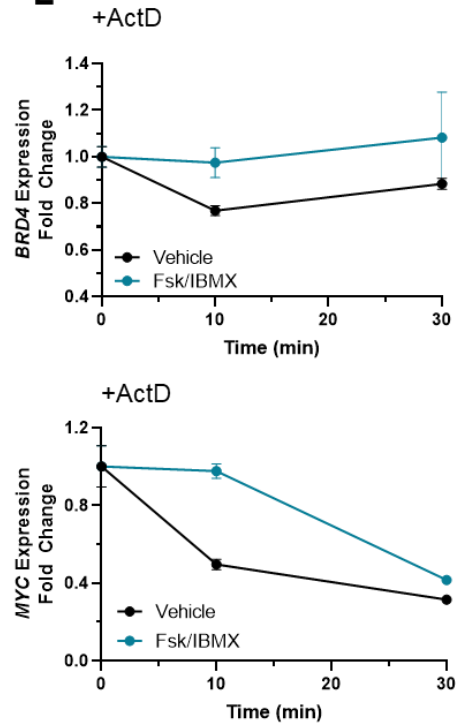
A**B****C****D****E**

line SKCO1 which harbors the activating hotspot mutation *GNAS* R201C, making the PKA pathway endogenously overactive. Interestingly we find that both PKA inhibitors, H89 and Rp-cAMP significantly decreased the basal level of RNAs harboring m6A modifications in the 3'UTR, including *BRD4* and *CDK6* (Figure 20C). Of note, the EPAC inhibitor, ESI-9, had little effect on *BRD4* and *CDK6* RNA levels. A similar effect of PKA inhibitors was also observed for *MYC*. Consistent with the specificity of IMPs for m6A modifications in the 3'UTR, PKA inhibitors had minimal effect of other RNAs with m6A present in the coding region. Given the robust effect of PKA inhibitors on basal RNA levels, we next stimulated PKA with the adenylyl cyclase activator forskolin and the phosphodiesterase inhibitor IBMX and followed the levels of RNA over time 30 minutes. Surprisingly we, find that forskolin/IBMX stimulation lead to a rapid increase in levels of *BRD4* and *MYC* RNA after just 10 minutes (Figure 20D). Given these rapid changes, we reasoned that the spike in RNA levels may represent direct stabilization effects, that prolong the half-life of unstable RNAs, of which *MYC* is known to be particularly unstable, with a half-life around 10 minutes (Dani et al., 1984). To test the direct effect on stability, we used actinomycin D to block transcription and track RNA levels during these early time points. Consistent with this idea, we observed that forskolin stabilized both *BRD4* and *MYC* RNA levels in the absence of transcription (Figure 20E). Finally, to determine if these effects on *BRD4* and *MYC* RNA stability were dependent on the complex between PKA α , HuR, and IMP1/3 we knockdown each protein with siRNAs (Figure 20F-G). Knockdown of all complex components significantly decreased basal *BRD4* RNA levels. Knockdown of complex components also decreased basal *MYC* levels, but not significantly, highlight that *MYC* RNA is regulated by multiple mechanisms.

BRD4 represented a potential therapeutic target

BRD4 is a bromodomain and extra-terminal domain (BET) family member that is known to bind acetylated lysines on histone tails to facilitate activation of target gene transcription. The mechanism by which *BRD4* mediates these effects is complex, including binding to other

chromatin regulators as well as transcription factors (Shi and Vakoc, 2014). Recently, BRD4 has also been reported to have its own acetyltransferase activity (Devaiah et al., 2016). Interestingly, MYC is one of the best studied transcriptional targets regulated by BRD4 (Shi and Vakoc, 2014). Given the potential ability of PKA to regulate both BRD4 and MYC at the RNA level, and their inherent regulation of each other, we wondered if these effects persist long term in cancer. Indeed, we find that BRD4 RNA expression strongly correlates with PRKACA RNA expression (Figure 21A). Furthermore, when PKA was stimulated by forskolin/IBMX in SKCO1 cells, protein levels of BRD4 and MYC increased robustly in as little as two hours, highlighting that enhanced stability ultimately promotes translation (Figure 21B). Recently, BRD4 inhibitors have garnered significant attention as they have been shown to downregulate MYC, which is often amplified in many cancer types (Xu and Vakoc, 2017). Given the promise of targeting the BRD4-MYC axis and the likely regulation of their RNA stability by PKA, we asked whether pathway sensitivity would predict sensitivity to knockdown of BRD4. Using sensitivity to GNAS knockdown across the large panel of cancer cell lines in the Cancer Cell Line Encyclopedia (CCLE) cell lines as a marker of overall pathway sensitivity, we find that indeed, GNAS-sensitive cancer cell lines were significantly more sensitive to BRD4 knockdown than GNAS-insensitive cancer cell lines (Figure 21C). Broadening these cell lines to include those that were also sensitive to knockdown of PRKACA or PRKACB, we asked if the pathway sensitive lines were also more sensitive to specific small molecule inhibitors. In line with the genetic data, we find several BRD4 inhibitors were among the top hits (Figure 21D). Of note, dactinomycin, an inhibitor of global transcription, was also among the top hits, highlighting the importance of the Gas-PKA pathway in driving transcriptional cell growth and tumorigenic programs. Finally, we aimed to validate these findings by selecting sensitive and insensitive cell lines. For validation, we selected the GNAS-sensitive cell line, SKCO1 (GNAS R201C mutant) and the GNAS-insensitive line, CAL27 (GNAS wild-type). SKCO1 was sensitive to the BRD4 inhibitor OTX-015, with an IC₅₀ of 484 nM while CAL27 was completely resistant (Figure 21E).

Figure 21. BRD4 is a potential therapeutic target in PKA pathway-driven cancers. A) Correlation of *PRKACA* levels of *BRD4* levels in cancer cell lines. Statistics determined by linear regression analysis. B) Western blot of BRD4 and MYC protein levels following stimulation with forskolin/IBMX (Fsk/IBMX) in SKCO1 cells. C) Comparison of *BRD4* gene effect in response to RNA interference (RNAi) in *GNAS*-insensitive and *GNAS*-sensitive cell lines. *GNAS* sensitivity was determined by gene effect scores in response to *GNAS* RNAi and used as a marker of pathway reliance. Statistics was determined by an unpaired t-test, *** $p < 0.001$. D) Drug sensitivities of pathway sensitive cell lines. Pathway sensitivity was determined by *GNAS*, *PRKACA*, or *PRKACB* gene effects. Drug sensitivity Z-scores were plotted. Top hits are highlighted in the dotted box, with BRD4 inhibitors shown in purple and a transcription inhibitor in teal. E) Validation of BRD4 inhibitor OTX-015 efficacy in the pathway sensitive line SKCO1 and pathway insensitive line CAL27. F) Mechanistic model of BRD4 inhibitor sensitivity in PKA pathway-driven cancers. Activation of PKA by upstream inputs (i.e. *GNAS* mutation or stimulation of Gas-coupled G protein coupled receptors (GPCRs)) promotes stabilization of IMP-1/3 target RNAs mediated through a physical interaction with HuR and PKA α . Strong IMP-1/3 target RNAs harbor m6A modification in their 3'UTR. Stabilization of target RNAs, such as *BRD4* and *MYC*, in response to PKA activation results in their translation to protein. BRD4 functions as an epigenetic regulator of MYC expression ultimately controlling activation of cancer promoting gene programs through MYC-mediated transcription. This mechanism provides a molecular basis for the sensitivity PKA pathway-driven cancers to BRD4 inhibitors.

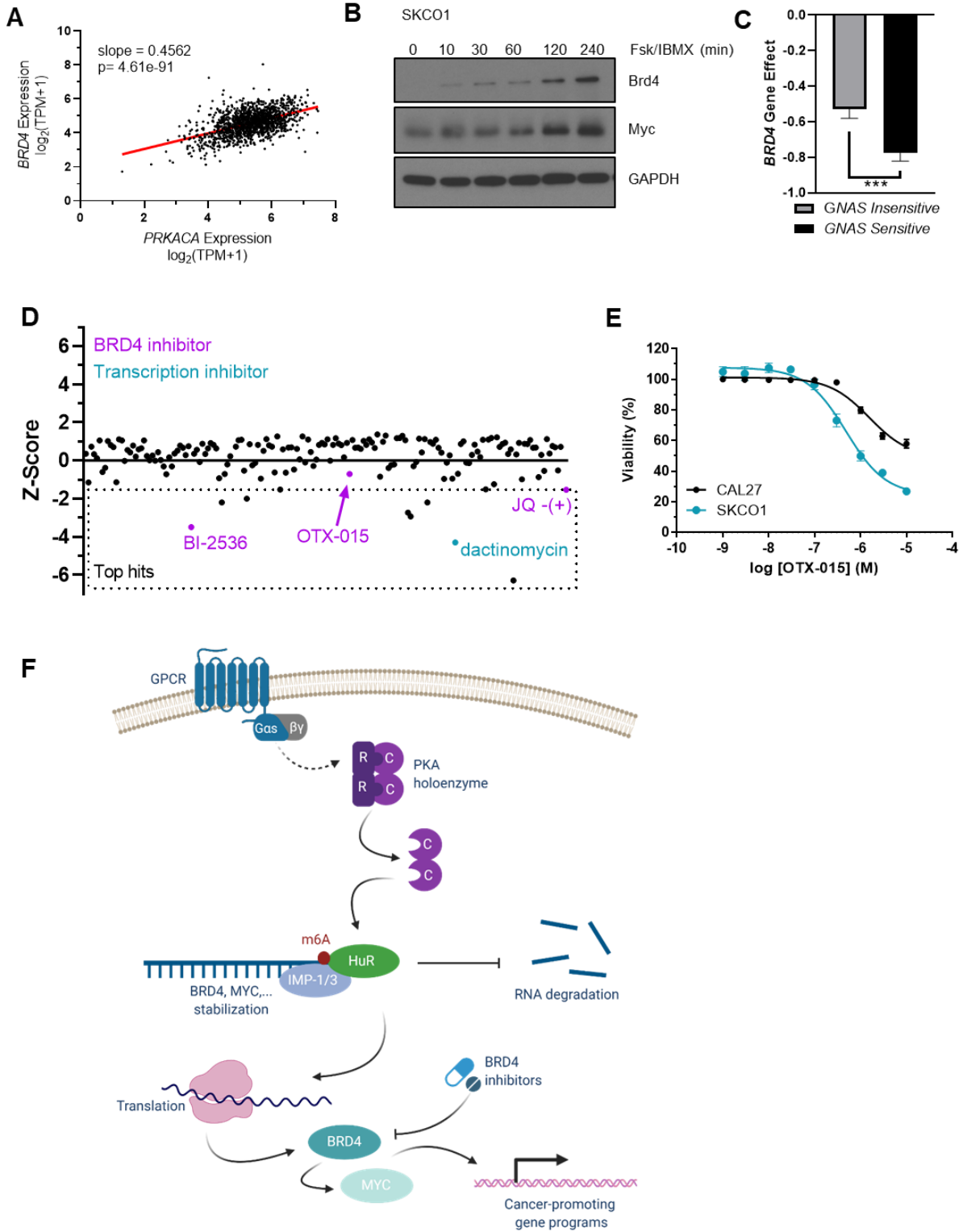

Together these data suggest that the regulation of *BRD4* RNA stability by PKA C α and the complex, including HuR and IMP-1/3, provide a molecular basis for sensitivity of PKA pathway-driven cancers to BRD4 inhibitors.

Discussion

PKA is known for its diverse roles in physiology, but its role in human diseases has remained largely unknown. Recent efforts by our group, have aimed at understanding genetic alterations present within the PKA pathway, identifying that the PKA pathway is largely mutational activated in cancer(Chapter 1, Ramms, et al). In order to better understand the role of the PKA pathway in cancer, we leveraged the behavior of disease-causing mutations to profile interactors of an active PKA by AP-MS. Our results recapitulated our biochemical understanding of these mutations, demonstrating that the active mutation of PKA C α completely lost regulatory subunit contacts, while the dominant-negative PKA R1 α mutation retained contacts with endogenous catalytic subunits even in the presence of constitutive cAMP-mediated pathway activation. Dramatically, we uncovered novel interactors conserved across multiple baits. Many of these interactors reflect biological processes that PKA is known to participate in such as cytoskeletal organization(Howe, 2004) and mitochondrial dynamics(Ould Amer and Hebert-Chatelain, 2018). Interestingly we reveal that PKA also contacts many proteins in chromatin organization, ribosomal biogenesis, and RNA binding, suggesting PKA may play more a widespread role in transcription and translation than previously appreciated.

PKA has long been known to regulate transcription, as is exemplified by PKA-mediated phosphorylation of CREB and activation of transcription through cAMP responsive elements (CREs) present near transcriptional start sites(Impey et al., 2004; Zhang et al., 2005). CREB-mediated transcription primarily drives hormone growth responses(Rosenberg et al., 2002). Interestingly, PKA can also participate in regulation of other transcriptional programs such Hippo,

Hedgehog, and Wnt, where phosphorylation of specific upstream pathway components controls activation of downstream transcription factors, such as TEADS, GLI, and β -catenin(Chapter 1, Ramms, et al). Previous work by our group has demonstrated that PKA's modulation of these transcriptional pathways can directly contribute to cancer initiation, progression, and lineage(Castellone et al., 2005; Ideno et al., 2018; Iglesias-Bartolome et al., 2015). In this study, we implicate PKA in regulation of posttranscriptional RNA stability through HuR and the IMP family of m6A-readers, opening up a broader contribution of PKA in modulation of transcriptional output.

Recent advances in sequencing technology and RNA interaction profiling (m6A-seq, eCLIP,...) have made it feasible to study RNA regulation like never before, generating large scale, unbiased data sets. Research on m6A, in particular, has exploded in recent years, identifying new roles for RBPs and their dysregulation in diseases such as cancer(He et al., 2019). Specifically, m6A writers like METTL3 and readers like IMP-2 have been found to be carcinogenic in colorectal and pancreatic cancers. However, these relationships are not completely understood as m6A erasers, e.g. FTO and ALKBH5 have opposing roles as an oncogene and tumor suppressor, respectively, in pancreatic cancer(Gu et al., 2020). Despite the complexity of m6A regulation, it is emerging into a promising therapeutic target, with interest in developing inhibitors to both writers and erasers. Recently, inhibitors of FTO have reported pre-clinical activity, suppressing growth and promoting differentiation in acute myeloid leukemia (AML) and inhibiting renewal of cancer stem cells in glioblastoma(Huang et al., 2019; Huff et al., 2021). Similarly, inhibitors and activators of writers, like METTL3 are also emerging for pre-clinical use(Bedi et al., 2020; Selberg et al., 2019). Perhaps the most exciting finding related to m6A machinery as a drug target is that action of these drugs are not uniform across all RNAs, allowing some specificity in which RNAs are regulated as part of oncogenic transcriptional programs. Furthermore, recent studies have highlighted that IMP family members, like IMP-3, are highly overexpressed in lung, stomach, and ovarian cancer(Mancarella and Scotlandi, 2020). While there is still much that is unknown about

how RNAs are regulated posttranscriptionally, specifically how particular RBPs are regulated in terms of the binding and localization, understanding these complex regulatory networks and their regulation will be essential to the clinical success of this novel class of drug targets. Here we provide the first evidence implicating PKA in the regulation of specific IMP-bound, m6A-modified RNAs, thereby identifying a new player m6A RNA regulation.

Finally, our understanding of PKA's modulation of RNA stability revealed an unexpected regulation of *BRD4*. While the promise of therapeutic targeting of BRD4 is exciting, particularly in its ability to regulate previously untargetable oncogenes like *MYC*, PKA's regulation of *BRD4* may implicate PKA in more global gene programs than previous appreciated through RNA regulation and perhaps even epigenetic regulation. Sparing reports have suggested PKA may participate in some epigenetic processes(Mathieu et al., 2018; Pattabiraman et al., 2016). One thing that is certain is that modulation of the PKA drives distinct phenotypes and alters differentiation states in many diseases(Ideno et al., 2018; Iglesias-Bartolome et al., 2015; Zhao et al., 2018). Implication of PKA in global gene programs regulated on the RNA level and/or epigenetic level certainly holds tremendous promise in understanding these phenotypes further.

In summary, we generated a dynamic map of PKA interactors by utilizing disease-causing mutations to favor the active state of the kinase. Novel RNA binding protein contacts revealed that PKA can modulated RNA stability and enhance translation of target RNAs such as *BRD4*. Current studies are aimed understanding the nature of PKA's regulation of RNA binding proteins, including potential functions as PKA substrates and the details of complex association. In total, these finding hold promise for understanding regulation of global gene programs and ultimately therapeutic targeting of PKA pathway-driven cancers.

Acknowledgements

Chapter 3, in full, is currently being prepared for submission for publication. Ramms, D.J., Adame-García, S.R., Burghi, V., Swaney, D.L., Arang, N., Zhou, Y. Stevenson, E., Taylor, S.S.,

Yeo, G.W., Krogan, N.J., and Gutkind, J.S. (2021). Protein-protein interaction map reveals a PKA regulated RNA binding protein network. The dissertation author was the primary investigator and author of this material.

I would also like to thank Dr. Friedrich Herberg at the University of Kassel and Dr. Bjørn Steen Skålhegg at the University of Oslo for their helpful discussions related to the PKA interactome map. I would like to thank past and current members of the Yeo lab, specifically Ryan Marina, Emily Wheeler, Jackie Einstein, Kris Brannan, and Steven Blue, for their help with reagents and technical advice. Finally, I would like to thank the many members of the Cancer Cell Map Initiative (CCMI) for scientific discussions and technical advice. I would like to acknowledge Biorender.com for assistance in generating graphics for this Chapter.

Methods

Reagents

Doxycycline was used at a final concentrations of 1µg/ml (Sigma, D9891-5G) for 48 hours unless otherwise noted. The adenylyl cyclase activator forskolin (Sigma, F3917-10MG) and the phosphodiesterase inhibitor 3-Isobutyl-1-methylxanthine (IBMX) (Sigma, I7018-100MG) were used together for all pathway stimulations at final concentrations of 10µM and 100µM, respectively.

Cell culture

HEK293A cells (ThermoFisher, R705-07) used for protein-protein interaction studies were obtained for Dr. Asuka Inoue at Tohoku University. HEK293T cells were purchased from ATCC (CRL-3216) and used to produce lentivirus. All HEK293 cells and engineered derivatives were cultured in DMEM (Sigma, D6429) with 10% fetal bovine serum (FBS) (Sigma, F2442) and 1% antibiotic cocktail (Sigma, A5955). SKCO1 (HTB-39) cells were obtained from ATCC and cultured

in MEM (Gibco, 11095-080) supplemented with 10% FBS and 1% antibiotic cocktail. CAL27 (CRL-2095) cells were obtained from ATCC and cultured in DMEM as described above.

Bait cloning

To generate bait constructs, cDNAs for wild-type and mutant murine PKA α and human PKA $\text{R}\alpha$ were transferred into the pDONR221 (ThermoFisher, 12536017) backbone using the Gateway system. Briefly, cDNAs were PCR amplified and recombined into the entry backbone using BP Clonase II according to manufacturer instructions (Invitrogen, 11789020). After confirming proper gene insertion with diagnostic digests, pDONR221 constructs were then transferred to the final pLVX TetOn 3xFLAG puro destination vector (Swaney et al, 2021) with the LR clonase (Invitrogen, 11791100). α constructs were tagged with a C-terminal 3xFLAG and $\text{R}\alpha$ constructs were tagged with an N-terminal 3x-FLAG. The *GNAS* R201C construct for constitutive expression was generated in the same manner with a final insertion in the plenti-CMV neomycin destination vector (Addgene, #17392). All constructs were confirmed with sequence and functional validation.

Lentiviral preparation and infection

HEK293T cells were plated on poly-lysine coated plates and transfected with lenti, packaging, and envelop plasmids at a 3:2:1 ratio using Turbofect (ThermoFisher, R0531). Viral supernatant was pooled after collection at 48 hour and 72 hours. After a brief centrifugation to remove cells, virus was filtered through 0.22 μ M PVDF filter (Millipore, SCGP00525). To generate the constitutive expressing *GNAS* R201C line, HEK293 cells were infected with lentivirus for 24 hours. After virus was removed, cells were selected in 500 μ g/ml neomycin (InvivoGen, ant-gn-1) for 5 days. Expression and function of *GNAS* R201C was confirmed after selection as described below. Next HEK293 and HEK293 *GNAS* R201C cell lines were each infected with bait lentiviruses. All lines were subject to selection in 1 μ g/ml puromycin (InvivoGen, ant-pr-1) for 5

days. Bait expression was induced with 1µg/ml doxycycline for 48 hours and expression and function were confirmed by western blotting for FLAG, Cα, R1α, and pPKA substrate as described below.

AP-MS, peptide identification, and interaction scoring

For detection of protein-protein interactions by affinity purification coupled with mass spectrometry (AP-MS), samples were prepared as previously described (Swaney et al, 2021). Briefly, cells were lysed after 48 hour treatment with or without 1µg/mL doxycycline. Baits were purified with FLAG magnetic beads and protein complexes were digested with trypsin. Peptides were identified by mass spectrometry and aligned based on Uniprot canonical human sequences. Results were filtered for a 1% false discovery rate and identified proteins scored using SAINTexpress(Teo et al., 2014). Proteins with a SAINT BFDR ≤ 0.2 were considered hits for the purpose of network visualization and further analysis.

Network visualization and enrichment analysis

Bait-prey interactions were visualized using Cytoscape(Shannon et al., 2003) with the stringApp(Doncheva et al., 2019) and enhancedGraphics(Morris et al., 2014). Networks were generated using results from bait-prey interactions among all Cα and all R1α baits and cell contexts, respectively. Nodes were colored based on log₂ fold change values among baits as indicated. STRING was then used to project high confidence interactions (interaction score >0.9) connecting related nodes. Manual curation of STRING functional enrichment results was used to assign broad functional groups for visualization purposes only. Functional enrichment for statistical purposes was performed with g:Profiler as previously described(Raudvere et al., 2019). To quantify network novelty, identified bait-prey interactions (BFDR ≤ 0.2) were queried across the

following public databases: BioPlex(Huttlin et al., 2021), STRING(Szkarczyk et al., 2019), CORUM(Giurgiu et al., 2019), BioGRID(Oughtred et al., 2021), IMEX(Orchard et al., 2012).

Western blotting

Cells were washed once with PBS and lysed on ice in RIPA (50mM Tris-HCl pH 6.8, 150mM NaCl, 1% NP-40, 0.5% sodium deoxycholate, 0.1% SDS) with protease and phosphatase inhibitors (Bimake, B14001, B15001-A/B). Lysates were sonicated and cleared by centrifugation before boiling in Laemmli sample buffer (Bio-Rad, 1610747). Samples were then separated on 10% acrylamide gels and transferred to PVDF membranes (Immobilon, IPVH304F0). Membranes were blocked and all subsequent antibody incubations occurred in 2% BSA in TBST. Primary antibodies include FLAG-HRP (Sigma, A8592, 1:5000), C α (Cell Signaling Technology, 5842, 1:2000), Rl α (Cell Signaling Technology, 3927, 1:1000), pPKA substrate (Cell Signaling Technology, 9621, 1:1000), pCREB (Cell Signaling Technology, 9198, 1:1000), CREB (Cell Signaling Technology, 9104, 1:1000), HuR (ThermoFisher, MA1-167, 1:2000), IMP-1 (MBL International, RN007P, 1:2000), IMP-3 (MBL International, RN009P, 1:2000), MYC (Cell Signaling Technologies, 5605, 1:2000), BRD4 (Bethyl Labs A700-004, 1:1000), GAPDH (Cell Signaling Technologies, 2118, 1:10000), α -tubulin (Cell Signaling Technologies, 3873, 1:10000) were used at the indicated dilution. After washing with TBST, membranes were incubated with goat anti-rabbit HRP (Southern Biotech, 4010-05, 1:40000) and goat anti-mouse HRP (Southern Biotech, 1010-05, 1:40000) antibodies for chemiluminescent development.

CRE luciferase assay

Bait expressing lines were transfected with firefly luciferase under the control of a cAMP responsive element (CRE-luc) (Promega, E8471) and renilla luciferase and treated with or without doxycycline. After 48 hours, luciferase activities were detected with the Dual-Glo assay system (Promega, E2920). For Rl α baits forskolin and IBMX were added overnight, the day prior to

reading the results. Raw luminescent values were first normalized to renilla to control for plasmid expression. Then relative luminescent counts were normalized to no doxycycline control. Statistical significance was determined with an unpaired t-test, *** $p < 0.001$.

Immunoprecipitation of FLAG-PKA

HEK293 cells were seeded on 10-cm plates coated with Poly-D-Lysine (Sigma, P7280-5MG) and transfected with the constructs FLAG-HaloTag, Flag-PKA-C α and FLAG-PKA-R1 α using Turbofect transfection reagent (ThermoFisher, R0531) according to the manufacturer's instructions and maintained in complete media. 48 hours after transfection, cells were washed one time with cold PBS and lysed with 1ml of Triton X-100 (Sigma, X100-100ML) 1% lysis buffer supplemented with protease and phosphatase inhibitors. Lysates were centrifuged at 21,000 x g for 15 minutes at 4°C. Supernatants were collected and a small aliquot was prepared as input lysate with Laemmli buffer 4X. The remaining supernatant was incubated with 20 μ l of anti-FLAG-M2 agarose beads (Millipore, IP04-1.5ML) at 4°C overnight. Next day the anti-FLAG beads were washed 4 times with 1 ml of Triton X-100 1% lysis buffer and suspended with 70 μ l of Laemmli buffer 1X. The samples were prepared for SDS-PAGE and immunoblot by heating at 95°C for 5 minutes and centrifuging at 21,000 x g for 2 minutes.

Immunofluorescence

HEK293 C α WT and R1 α WT cells were plated on poly-lysine coated coverslips. The following day, cells were transfected with pCEFL-eGFP-HuR using Lipofectamine 3000 (Invitrogen L3000-008) according the manufacture instructions. Cells were then treated with doxycycline to induce bait expression. After 48 hours, media was aspirated and cells fixed with 4% paraformaldehyde (Electron Microscopy Sciences, 157-8-100) in PBS for 15 minutes at room temperature. Then cells were washed 3 times for 5 minutes with wash buffer (0.01% Triton X-100 in PBS). Cells were blocked and permeabilized using 2% goat serum (ThermoFisher, 50197Z)

with 0.1% Triton X-100 for 1 hour at room temperature. After washing with wash buffer, cells were incubated overnight in primary antibody against FLAG at 4°C (Cell Signaling Technologies, 8146 or 14793, 1:1000) in 2% goat serum. The next day cells were washed with wash buffer and incubated for 1 hour at room temperature with secondary antibody (Alexa Fluor 594 Goat anti-mouse or anti-rabbit, Life Technologies, A21125 or A11037) and nuclear counterstain (TO-PRO-3 iodide 642/661, Life Technologies, T3605) in 2% goat serum. Finally, cells were washed 3 times with PBS before mounting the coverslips on slides (ProLong Gold Antifade, Invitrogen, P36930).

Identification of candidate m6A RNAs bound by IMPs

To generate a candidate list of m6A RNAs bound by IMPs, published m6A-seq data was obtained (Dominissini et al., 2012; Meyer et al., 2012). Experiments were conducted across two different cell lines (HepG2, HEK293T). Similarly, to identify RNAs bound by IMP family members, results of eCLIP datasets for IMP-1, IMP-2, and IMP-3, were downloaded (Huang et al., 2018; Van Nostrand et al., 2020). Experiments were performed across three cell lines, K562, HepG2, and HEK293T. Lists of RNAs were cross referenced to and manually curated based on cancer relevance (Table S9).

Gene knockdown with siRNA

For siRNA knockdown experiments, SKCO1 cells were plated on poly-lysine coated 6 well plates. The following day, siRNAs were transfected using RNAi Max (ThermoFisher, 13778075) according to the manufacture instruction with 75pmol per well (25µM stock). Indicated pooled siRNAs were obtained from Horizon Discovery Biosciences/Dharmacon: Control (D-001810-10-20), *ELAVL1* (L-003773-00-0005), *IGF2BP1* (L-003977-00-0005), *IGF2BP3* (L-003976-00-0005), and *PRKACA* (L-004649-00-0005). Cells were incubated for 48 to 72 hours before collecting samples for western blotting or RT-qPCR.

RNA stability assays and RT-qPCR

To assess the effect of PKA inhibition on basal RNA levels, SKCO1 cells were treated with DMSO vehicle, H89 (Selleck Chem, S1582), Rp-cAMPS (Tocris, 1337), or ESI-09 (Selleck Chem, S7499) for two hours. Cells were washed once and RNA extracted (Qiagen, 74104). RNA concentrations were normalized and converted to cDNA using the SuperScript VILO cDNA synthesis kit (Invitrogen, 11754-050). Fast SYBR Green (Applied Bio Systems, 4385612) was used measure RNA levels of the indicated genes by qPCR (Applied Bio Systems, QuantStudio 6 Flex). Primer pairs are listed in Table S10. CT values were normalized to GAPDH unless otherwise indicated and expressed as \log_2 fold change ($-\Delta\Delta CT$). To determine the effect of pathway stimulation on *BRD4* and *MYC* RNA levels, SKCO1 cells were stimulated with vehicle or forskolin/IBMX for the indicated amount of time and samples processed as above.

For RNA stability assay, SKCO1 cells were treated with DMSO vehicle or 10 μ M forskolin and 100 μ M IBMX along with 10 μ M actinomycin D (Sigma, A1410-2MG) for the indicated time. Untreated cells were represented as time 0. CT values were normalized to *GAPDH*, which did not change with actinomycin D treatment.

Analysis of cancer cell line expression patterns

Expression correlation analysis was performed using cancer cell line data from DepMap data portal(<https://depmap.org/portal/>). Public expression data (21Q1)(Dempster et al., 2019; Ghandi et al., 2019; Meyers et al., 2017) was directly downloaded for each gene of interest. *PRKACA* high and *PRKACA* low cells were specified based on the top 50 and bottom 50 expressing cells respectively. Expression counts are represented $\log_2(TPM+1)$, where TPM is transcripts per million). Statistical significance was assessed using an unpaired t-test or simple linear regression in GraphPad prism.

Drug screen and GNAS-sensitive BRD4 gene effects

First, pathway sensitive cells were specified according to the top 20 scoring cell lines for each *GNAS*, *PRKACA*, and *PRKACB* gene effects from the combined RNAi dataset (DEMETER2 Data v6)(McFarland et al., 2018) available on the DepMap data portal. Next the Sanger Drug Sensitivity AUC (GDSC2)(Picco et al., 2019) was downloaded from DepMap and average area under the curve (AUC) were calculated for each drug in the pathway sensitive cells. Next, Z-scores ($Z=(x-\mu)/\sigma$) were calculated for each drug where x was the average AUC of the pathway sensitive cells, μ is the population mean of AUCs for all available cell lines, and σ is the standard deviation of the same population. Z-scores were then plotted, with a negative Z-score representing drug sensitivities of pathway sensitive cells.

To define *GNAS*-sensitive and *GNAS*-insensitive cells, groups were assigned based on the top 50 and bottom 50 scoring cell lines from the combined RNAi dataset mentioned previously. Average *BRD4* gene effect was then calculated for each group and plotted. Statistical significance was assessed with an unpaired t-test, *** $p<0.001$.

Cell proliferation assays

GNAS-sensitive (SKCO1) and insensitive (CAL27) cells were selected from the groups specified above. Cells were plated in 96 well plates and treated with BRD4 inhibitor the following day (SKCO1: 8,000 cells/well, CAL27: 4,000 cells/well). OTX-015 (SelleckChem, S7360) stock was dissolved in ethanol. Half log serial dilutions were prepared in PBS for indicated concentrations. Cells were included for 5 days with the drug. On the 5th day, cells were incubated with AquaBluer (MultiTarget Pharmaceuticals, 6001) for 4 hours before reading fluorescence (Tecan Spark). Proliferation was quantified according to the manufacturer instructions. IC_{50} values were determined in GraphPad Prism by fitting a nonlinear regression curve.

Extended Data

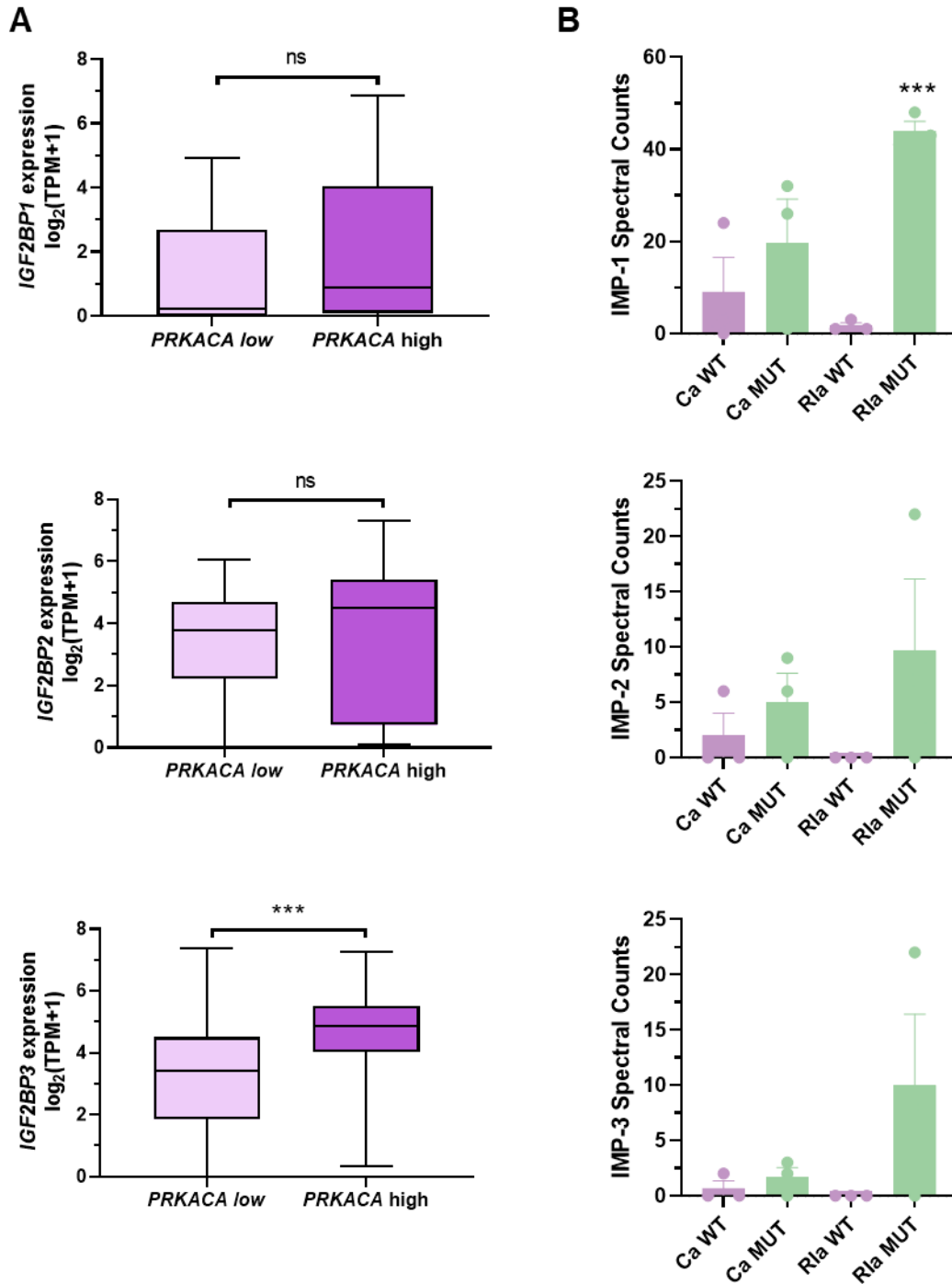

Figure S1. PKA interactions with IMP family members. A) Correlation of *PRKACA* expression with expression of IMPs, IMP-1 (*IGF2BP1*) B) IMP-2 (*IGF2BP2*), C) IMP-3 (*IGF2BP3*) across cancer cell lines. B) Comparison of spectral counts for PKA Ca baits in the parental context and PKA R1a baits in the pathway active context. Statistical significance was determined by an unpaired t-test, *** $p < 0.001$ in both A) and B).

CONCLUSION

Protein kinase A (PKA) is a master regulator of physiology, coordinating fundamental processes ranging from metabolism to cellular growth and development across diverse cell types and organ systems. By operating within discrete signaling microdomains that integrate inputs from multiple sources across space and time, PKA is able to organize complex regulatory networks and initiate precise biological outcomes. Despite our detailed understanding of PKA's biochemical activity and its effect on discrete substrates and more global programs, the contribution of these actions to disease remains unclear. With this dissertation I take the first steps in understanding these roles by profiling mutational landscapes, developing mouse models, and mapping physical interactors.

In Chapter 1, I perform the first systematic analysis of G α s-PKA pathway alterations in disease. Leveraging functional information from monogenetic diseases, I find examples of both pathway activation and inactivation, implicating many nodes of the pathway from the G α s G protein, to adenylyl cyclase and phosphodiesterase isoforms, and both regulatory and catalytic subunits of the kinase. Surprisingly, I find these mutational themes extend to cancer, where pathway activation seems to be particularly important. Building on these mutational patterns, in Chapter 2, I generate several mouse models to recapitulate the genetic interaction of *GNAS* and *KRAS* co-mutation in cancer, uncovering a robust role for *GNAS* in cancer initiation. I also recapitulate unique clinical phenotype associated with *GNAS* mutation such as cystic morphology and mucin production. Finally, in Chapter 3, I exploit our understanding of PKA pathway mutation and function to profile the physical interactome of PKA. Specifically, I focus on interactors of the active kinase to discover novel RNA binding protein contacts. Through mechanistic analysis I reveal that PKA enhances RNA stability through physical interactions with HuR and IMP-1/3 that ultimately predict sensitivity to BRD4 inhibitors *in vitro*.

In total, this dissertation makes important progress by unifying the view of PKA-driven pathophysiology under the umbrella of “G α s-PKA pathway signalopathies”. I provide tools and resources aimed to bridge biochemical understanding with cellular function and ultimately pathophysiology and clinical practice. It is our hope that by unify this field we can catalyze the understanding of disease mechanisms and ultimately the identification of therapeutic vulnerabilities. With the diverse roles of PKA pathway in biology, undoubtedly, we face many challenges in differentiating between physiologic and pathophysiologic roles of PKA in an attempt to identify therapeutic windows for intervention. However, given the specificity conferred by differential isoform expression and mutation across cell types, deep mechanistic understanding of these functions holds tremendous promise. Furthermore, with the rapid advances of multi-omic technologies, we are uncovering more and more unexpected roles of PKA, shedding even more light on potential disease mechanisms. Just as PKA connects disparate cellular components, I hope that by understanding the “G α s-PKA pathway signalopathies” the effects can also be far reaching and ultimately result in real advances in the treatment of PKA pathway-driven disease.

REFERENCES

- Abdelmohsen K (2012) Modulation of Gene Expression by RNA Binding Proteins: mRNA Stability and Translation, Binding Protein, IntechOpen.
- Abel EL, Angel JM, Kiguchi K and DiGiovanni J (2009) Multi-stage chemical carcinogenesis in mouse skin: fundamentals and applications. *Nature protocols*4:1350-1362.
- Acin-Perez R, Salazar E, Kamenetsky M, Buck J, Levin LR and Manfredi G (2009) Cyclic AMP Produced inside Mitochondria Regulates Oxidative Phosphorylation. *Cell Metab*9:265-276.
- Adams JA, McGlone ML, Gibson R and Taylor SS (1995) Phosphorylation modulates catalytic function and regulation in the cAMP-dependent protein kinase. *Biochemistry*34:2447-2454.
- Alakus H, Babicky ML, Ghosh P, Yost S, Jepsen K, Dai Y, Arias A, Samuels ML, Mose ES, Schwab RB, Peterson MR, Lowy AM, Frazer KA and Harismendy O (2014) Genome-wide mutational landscape of mucinous carcinomatosis peritonei of appendiceal origin. *Genome Med*6:43.
- Alam H, Tang M, Maitituoheti M, Dhar SS, Kumar M, Han CY, Ambati CR, Amin SB, Gu B, Chen TY, Lin YH, Chen J, Muller FL, Putluri N, Flores ER, DeMayo FJ, Baseler L, Rai K and Lee MG (2020) KMT2D Deficiency Impairs Super-Enhancers to Confer a Glycolytic Vulnerability in Lung Cancer. *Cancer Cell*37:599-617.e597.
- Alberini CM, Ghirardi M, Metz R and Kandel ER (1994) C/EBP is an immediate-early gene required for the consolidation of long-term facilitation in Aplysia. *Cell*76:1099-1114.
- Ali M, Nelson AR, Lopez AL and Sack DA (2015) Updated global burden of cholera in endemic countries. *PLoS Negl Trop Dis*9:e0003832-e0003832.
- Almeida MQ, Azevedo MF, Xekouki P, Bimpaki EI, Horvath A, Collins MT, Karaviti LP, Jeha GS, Bhattacharyya N, Cheadle C, Watkins T, Bourdeau I, Nesterova M and Stratakis CA (2012) Activation of cyclic AMP signaling leads to different pathway alterations in lesions of the adrenal cortex caused by germline PRKAR1A defects versus those due to somatic GNAS mutations. *J Clin Endocrinol Metab*97:E687-E693.
- Almeida MQ, Muchow M, Boikos S, Bauer AJ, Griffin KJ, Tsang KM, Cheadle C, Watkins T, Wen F, Starost MF, Bossis I, Nesterova M and Stratakis CA (2010) Mouse Prkar1a haploinsufficiency leads to an increase in tumors in the Trp53^{+/-} or Rb1^{+/-} backgrounds and chemically induced skin papillomas by dysregulation of the cell cycle and Wnt signaling. *Hum Mol Genet*19:1387-1398.
- Altarejos JY and Montminy M (2011) CREB and the CRTC co-activators: sensors for hormonal and metabolic signals. *Nat Rev Mol Cell Biol*12:141-151.
- Amarante MK, Vitiello GAF, Rosa MH, Mancilla IA and Watanabe MAE (2018) Potential use of CXCL12/CXCR4 and sonic hedgehog pathways as therapeutic targets in medulloblastoma. *Acta Oncol*57:1134-1142.

- Amato E, Molin MD, Mafficini A, Yu J, Malleo G, Rusev B, Fassan M, Antonello D, Sadakari Y, Castelli P, Zamboni G, Maitra A, Salvia R, Hruban RH, Bassi C, Capelli P, Lawlor RT, Goggins M and Scarpa A (2014) Targeted next-generation sequencing of cancer genes dissects the molecular profiles of intraductal papillary neoplasms of the pancreas. *J Pathol*233:217-227.
- Amieux PS and McKnight GS (2002) The essential role of RI alpha in the maintenance of regulated PKA activity. *Ann N Y Acad Sci*968:75-95.
- Ang CS-P, Shen JP, Hardy-Abeloos CJ, Huang JK, Ross JS, Miller VA, Jacobs MT, Chen IL, Xu D, Ali SM, Baumgartner J, Lowy A, Fanta P, Ideker T, Millis SZ and Harismendy O (2018) Genomic Landscape of Appendiceal Neoplasms. *JCO Precision Oncology*:1-18.
- Angers S and Moon RT (2009) Proximal events in Wnt signal transduction. *Nat Rev Mol Cell Biol*10:468-477.
- Arang N and Gutkind JS (2020) G Protein-Coupled receptors and heterotrimeric G proteins as cancer drivers. *FEBS Lett*594:4201-4232.
- Ardeshir-Larijani F, Bhateja P, Lipka MB, Sharma N, Fu P and Dowlati A (2018) KMT2D Mutation Is Associated With Poor Prognosis in Non-Small-Cell Lung Cancer. *Clin Lung Cancer*19:e489-e501.
- Arveseth CD, Happ JT, Hedeem DS, Zhu JF, Capener JL, Klatt Shaw D, Deshpande I, Liang J, Xu J, Stubben SL, Nelson IB, Walker MF, Kawakami K, Inoue A, Krogan NJ, Grunwald DJ, Hüttenhain R, Manglik A and Myers BR (2021) Smoothed transduces Hedgehog signals via activity-dependent sequestration of PKA catalytic subunits. *PLoS Biol*19:e3001191.
- Asare EA, Compton CC, Hanna NN, Kosinski LA, Washington MK, Kakar S, Weiser MR and Overman MJ (2016) The impact of stage, grade, and mucinous histology on the efficacy of systemic chemotherapy in adenocarcinomas of the appendix: Analysis of the National Cancer Data Base. *Cancer*122:213-221.
- Ashworth A and Lord CJ (2018) Synthetic lethal therapies for cancer: what's next after PARP inhibitors? *Nat Rev Clin Oncol*15:564-576.
- Aye TT, Mohammed S, van den Toorn HWP, van Veen TAB, van der Heyden MAG, Scholten A and Heck AJR (2009) Selectivity in enrichment of cAMP-dependent protein kinase regulatory subunits type I and type II and their interactors using modified cAMP affinity resins. *Molecular & cellular proteomics : MCP*8:1016-1028.
- Bachmann VA, Mayrhofer JE, Ilouz R, Tschalkner P, Raffeiner P, Röck R, Courcelles M, Apelt F, Lu T-W, Baillie GS, Thibault P, Aanstad P, Stelzl U, Taylor SS and Stefan E (2016) Gpr161 anchoring of PKA consolidates GPCR and cAMP signaling. *Proc Natl Acad Sci U S A*113:7786-7791.
- Bacskai BJ, Hochner B, Mahaut-Smith M, Adams SR, Kaang BK, Kandel ER and Tsien RY (1993) Spatially resolved dynamics of cAMP and protein kinase A subunits in *Aplysia* sensory neurons. *Science*260:222-226.

- Baker L, Tiriac H, Corbo V and Young CM (2017) Tuveson Laboratory Murine and Human Organoid Protocols.
- Bangs F and Anderson KV (2017) Primary Cilia and Mammalian Hedgehog Signaling. Cold Spring Harb Perspect Biol9:a028175.
- Barker N (2014) Adult intestinal stem cells: critical drivers of epithelial homeostasis and regeneration. Nature Reviews Molecular Cell Biology15:19-33.
- Barretina J, Caponigro G, Stransky N, Venkatesan K, Margolin AA, Kim S, Wilson CJ, Lehár J, Kryukov GV, Sonkin D, Reddy A, Liu M, Murray L, Berger MF, Monahan JE, Morais P, Meltzer J, Korejwa A, Jané-Valbuena J, Mapa FA, Thibault J, Bric-Furlong E, Raman P, Shipway A, Engels IH, Cheng J, Yu GK, Yu J, Aspesi P, de Silva M, Jagtap K, Jones MD, Wang L, Hatton C, Palesscandolo E, Gupta S, Mahan S, Sougnez C, Onofrio RC, Liefeld T, MacConaill L, Winckler W, Reich M, Li N, Mesirov JP, Gabriel SB, Getz G, Ardlie K, Chan V, Myer VE, Weber BL, Porter J, Warmuth M, Finan P, Harris JL, Meyerson M, Golub TR, Morrissey MP, Sellers WR, Schlegel R and Garraway LA (2012) The Cancer Cell Line Encyclopedia enables predictive modelling of anticancer drug sensitivity. Nature483:603-607.
- Barzi M, Berenguer J, Menendez A, Alvarez-Rodriguez R and Pons S (2010) Sonic-hedgehog-mediated proliferation requires the localization of PKA to the cilium base. J Cell Sci123:62-69.
- Bates B, Zhang L, Nawoschik S, Kodangattil S, Tseng E, Kopsco D, Kramer A, Shan Q, Taylor N, Johnson J, Sun Y, Chen HM, Blatcher M, Paulsen JE and Pausch MH (2006) Characterization of Gpr101 expression and G-protein coupling selectivity. Brain Res1087:1-14.
- Bathon K, Weigand I, Vanselow JT, Ronchi CL, Sbiera S, Schlosser A, Fassnacht M and Calebiro D (2019) Alterations in Protein Kinase A Substrate Specificity as a Potential Cause of Cushing Syndrome. Endocrinology160:447-459.
- Bedi RK, Huang D, Eberle SA, Wiedmer L, Śledź P and Caflisch A (2020) Small-Molecule Inhibitors of METTL3, the Major Human Epitranscriptomic Writer. ChemMedChem15:744-748.
- Bell JL, Wächter K, Mühleck B, Pazaitis N, Köhn M, Lederer M and Hüttelmaier S (2013) Insulin-like growth factor 2 mRNA-binding proteins (IGF2BPs): post-transcriptional drivers of cancer progression? Cellular and molecular life sciences : CMLS70:2657-2675.
- Belteki G, Haigh J, Kabacs N, Haigh K, Sison K, Costantini F, Whitsett J, Quaggin SE and Nagy A (2005) Conditional and inducible transgene expression in mice through the combinatorial use of Cre-mediated recombination and tetracycline induction. Nucleic Acids Res33:e51.
- Bender AT and Beavo JA (2006) Cyclic Nucleotide Phosphodiesterases: Molecular Regulation to Clinical Use. Pharmacol Rev58:488-520.

- Bendzun NG, Dörfler S, Autenrieth K, Bertinetti D, Machal EMF, Kennedy EJ and Herberg FW (2018) Investigating PKA-RII specificity using analogs of the PKA:AKAP peptide inhibitor STAD-2. *Bioorg Med Chem*26:1174-1178.
- Bentin Toaldo C, Alexi X, Beelen K, Kok M, Hauptmann M, Jansen M, Berns E, Neefjes J, Linn S, Michalides R and Zwart W (2015) Protein Kinase A-induced tamoxifen resistance is mediated by anchoring protein AKAP13. *BMC Cancer*15:588.
- Berman HM, Ten Eyck LF, Goodsell DS, Haste NM, Kornev A and Taylor SS (2005) The cAMP binding domain: An ancient signaling module. *Proc Natl Acad Sci U S A*102:45-50.
- Bertherat J, Horvath A, Groussin L, Grabar S, Boikos S, Cazabat L, Libe R, René-Corail F, Stergiopoulos S, Bourdeau I, Bei T, Clauser E, Calender A, Kirschner LS, Bertagna X, Carney JA and Stratakis CA (2009) Mutations in regulatory subunit type 1A of cyclic adenosine 5'-monophosphate-dependent protein kinase (PRKAR1A): phenotype analysis in 353 patients and 80 different genotypes. *J Clin Endocrinol Metab*94:2085-2091.
- Bertinetti D, Schweinsberg S, Hanke SE, Schwede F, Bertinetti O, Drewianka S, Genieser HG and Herberg FW (2009) Chemical tools selectively target components of the PKA system. *BMC Chem Biol*9:3.
- Beuschlein F, Fassnacht M, Assié G, Calebiro D, Stratakis CA, Osswald A, Ronchi CL, Wieland T, Sbiera S, Faucz FR, Schaak K, Schmittfull A, Schwarzmayer T, Barreau O, Vezzosi D, Rizk-Rabin M, Zabel U, Szarek E, Salpea P, Forlino A, Vetro A, Zuffardi O, Kisker C, Diener S, Meitinger T, Lohse MJ, Reincke M, Bertherat J, Strom TM and Allolio B (2014) Constitutive activation of PKA catalytic subunit in adrenal Cushing's syndrome. *N Engl J Med*370:1019-1028.
- Bharati K and Ganguly NK (2011) Cholera toxin: a paradigm of a multifunctional protein. *Indian J Med Res*133:179-187.
- Bi WL, Greenwald NF, Ramkissoon SH, Abedalthagafi M, Coy SM, Ligon KL, Mei Y, MacConaill L, Ducar M, Min L, Santagata S, Kaiser UB, Beroukhi R, Laws ER, Jr. and Dunn IF (2017) Clinical Identification of Oncogenic Drivers and Copy-Number Alterations in Pituitary Tumors. *Endocrinology*158:2284-2291.
- Bian X, Yang S, Chen J, Ping Y, Zhou X, Wang Q, Jiang X, Gong W, Xiao H, Du L, Chen Z, Zhao W, Shi J and Wang JM (2007) Preferential expression of chemokine receptor CXCR4 by highly malignant human gliomas and its association with poor patient survival. *Neurosurgery*61:570-579.
- Bianco P, Kuznetsov SA, Riminucci M, Fisher LW, Spiegel AM and Robey PG (1998) Reproduction of human fibrous dysplasia of bone in immunocompromised mice by transplanted mosaics of normal and Gsalpha-mutated skeletal progenitor cells. *J Clin Invest*101:1737-1744.
- Biel M (2009) Cyclic nucleotide-regulated cation channels. *J Biol Chem*284:9017-9021.
- Birchenough GMH, Johansson ME, Gustafsson JK, Bergström JH and Hansson GC (2015) New developments in goblet cell mucus secretion and function. *Mucosal Immunol*8:712-719.

- Bitterman JL, Ramos-Espiritu L, Diaz A, Levin LR and Buck J (2013) Pharmacological distinction between soluble and transmembrane adenylyl cyclases. *J Pharmacol Exp Ther*347:589-598.
- Blair CM and Baillie GS (2019) Reshaping cAMP nanodomains through targeted disruption of compartmentalised phosphodiesterase signalosomes. *Biochem Soc Trans*47:1405-1414.
- Bock A, Annibale P, Konrad C, Hannawacker A, Anton SE, Maiellaro I, Zabel U, Sivaramakrishnan S, Falcke M and Lohse MJ (2020) Optical Mapping of cAMP Signaling at the Nanometer Scale. *Cell*182:1519-1530.e1517.
- Boikos SA and Stratakis CA (2007) Molecular genetics of the cAMP-dependent protein kinase pathway and of sporadic pituitary tumorigenesis. *Hum Mol Genet*16:R80-R87.
- Boora GK, Kanwar R, Kulkarni AA, Pleticha J, Ames M, Schroth G, Beutler AS and Banck MS (2015) Exome-level comparison of primary well-differentiated neuroendocrine tumors and their cell lines. *Cancer Genet*208:374-381.
- Boswell-Smith V, Spina D and Page CP (2006) Phosphodiesterase inhibitors. *Br J Pharmacol*147 Suppl 1:S252-S257.
- Böttcher JP, Bonavita E, Chakravarty P, Bles H, Cabeza-Cabrero M, Sammiceli S, Rogers NC, Sahai E, Zelenay S and Reis e Sousa C (2018) NK Cells Stimulate Recruitment of cDC1 into the Tumor Microenvironment Promoting Cancer Immune Control. *Cell*172:1022-1037.e1014.
- Bradley J, Reiser J and Frings S (2005) Regulation of cyclic nucleotide-gated channels. *Curr Opin Neurobiol*15:343-349.
- Bramson HN, Kaiser ET and Mildvan AS (1984) Mechanistic studies of cAMP-dependent protein kinase action. *CRC Crit Rev Biochem*15:93-124.
- Brasaemle DL, Subramanian V, Garcia A, Marcinkiewicz A and Rothenberg A (2008) Perilipin A and the control of triacylglycerol metabolism. *Mol Cell Biochem*326:15.
- Brockmann M, Blomen VA, Nieuwenhuis J, Stickel E, Raaben M, Bleijerveld OB, Altelaar AFM, Jae LT and Brummelkamp TR (2017) Genetic wiring maps of single-cell protein states reveal an off-switch for GPCR signalling. *Nature*546:307-311.
- Brogna S and Wen J (2009) Nonsense-mediated mRNA decay (NMD) mechanisms. *Nat Struct Mol Biol*16:107-113.
- Brown JR and DuBois RN (2005) COX-2: a molecular target for colorectal cancer prevention. *J Clin Oncol*23:2840-2855.
- Brown RL, Strassmaier T, Brady JD and Karpen JW (2006) The pharmacology of cyclic nucleotide-gated channels: emerging from the darkness. *Curr Pharm Des*12:3597-3613.
- Brown SH, Cheng CY, Saldanha SA, Wu J, Cottam HB, Sankaran B and Taylor SS (2013) Implementing fluorescence anisotropy screening and crystallographic analysis to define PKA isoform-selective activation by cAMP analogs. *ACS Chem Biol*8:2164-2172.

- Brunelli M, Castellucci V and Kandel ER (1976) Synaptic facilitation and behavioral sensitization in *Aplysia*: possible role of serotonin and cyclic AMP. *Science*194:1178-1181.
- Bruystens JG, Wu J, Fortezzo A, Del Rio J, Nielsen C, Blumenthal DK, Rock R, Stefan E and Taylor SS (2016) Structure of a PKA RI α Recurrent Acrodysostosis Mutant Explains Defective cAMP-Dependent Activation. *J Mol Biol*428:4890-4904.
- Buckman SY, Gresham A, Hale P, Hruza G, Anast J, Masferrer J and Pentland AP (1998) COX-2 expression is induced by UVB exposure in human skin: implications for the development of skin cancer. *Carcinogenesis*19:723-729.
- Bucko PJ and Scott JD (2020) Drugs that Regulate Local Cell Signaling: AKAP Targeting as a Therapeutic Option. *Annu Rev Pharmacol Toxicol*.
- Bucko PJ, Lombard CK, Rathbun L, Garcia I, Bhat A, Wordeman L, Smith FD, Maly DJ, Hehnlly H and Scott JD (2019) Subcellular drug targeting illuminates local kinase action. *eLife*8:e52220.
- Burgers PP, Ma Y, Margarucci L, Mackey M, van der Heyden MA, Ellisman M, Scholten A, Taylor SS and Heck AJ (2012) A small novel A-kinase anchoring protein (AKAP) that localizes specifically protein kinase A-regulatory subunit I (PKA-RI) to the plasma membrane. *J Biol Chem*287:43789-43797.
- Calatuzzolo C, Maderna E, Pollo B, Gelati M, Marras CE, Silvani A, Croci D, Boiardi A and Salmaggi A (2006) Prognostic value of CXCL12 expression in 40 low-grade oligodendrogliomas and oligoastrocytomas. *Cancer Biol Ther*5:827-832.
- Calebiro D, Hannawacker A, Lyga S, Bathon K, Zabel U, Ronchi C, Beuschlein F, Reincke M, Lorenz K, Allolio B, Kisker C, Fassnacht M and Lohse MJ (2014) PKA catalytic subunit mutations in adrenocortical Cushing's adenoma impair association with the regulatory subunit. *Nat Commun*5:5680.
- Calejo AI and Taskén K (2015) Targeting protein-protein interactions in complexes organized by A kinase anchoring proteins. *Front Pharmacol*6:192.
- Campbell AP and Smrcka AV (2018) Targeting G protein-coupled receptor signalling by blocking G proteins. *Nat Rev Drug Discov*17:789-803.
- Cannaerts E, van de Beek G, Verstraeten A, Van Laer L and Loeys B (2015) TGF- β signalopathies as a paradigm for translational medicine. *Eur J Med Genet*58:695-703.
- Cao B, Lu TW, Martinez Fiesco JA, Tomasini M, Fan L, Simon SM, Taylor SS and Zhang P (2019) Structures of the PKA RI α Holoenzyme with the FLHCC Driver J-PKAc α or Wild-Type PKAc α . *Structure*27:816-828.e814.
- Carballo GB, Honorato JR, de Lopes GPF and Spohr TCLdSe (2018) A highlight on Sonic hedgehog pathway. *Cell Commun Signal*16:11.
- Carlson CR, Ruppelt A and Taskén K (2003) A kinase anchoring protein (AKAP) interaction and dimerization of the RI α and RI β regulatory subunits of protein kinase a in vivo by the yeast two hybrid system. *J Mol Biol*327:609-618.

- Carney JA (1985) Differences between nonfamilial and familial cardiac myxoma. *Am J Surg Pathol*9:53-55.
- Carr DW, Stofko-Hahn RE, Fraser ID, Cone RD and Scott JD (1992) Localization of the cAMP-dependent protein kinase to the postsynaptic densities by A-kinase anchoring proteins. Characterization of AKAP 79. *J Biol Chem*267:16816-16823.
- Castellone MD, Teramoto H, Williams BO, Druey KM and Gutkind JS (2005) Prostaglandin E2 promotes colon cancer cell growth through a Gs-axin-beta-catenin signaling axis. *Science*310:1504-1510.
- Castellucci VF, Kandel ER, Schwartz JH, Wilson FD, Nairn AC and Greengard P (1980) Intracellular injection of the catalytic subunit of cyclic AMP-dependent protein kinase simulates facilitation of transmitter release underlying behavioral sensitization in *Aplysia*. *Proc Natl Acad Sci U S A*77:7492-7496.
- Cerami E, Gao J, Dogrusoz U, Gross BE, Sumer SO, Aksoy BA, Jacobsen A, Byrne CJ, Heuer ML, Larsson E, Antipin Y, Reva B, Goldberg AP, Sander C and Schultz N (2012) The cBio cancer genomics portal: an open platform for exploring multidimensional cancer genomics data. *Cancer Discov*2:401-404.
- Chan AT, Giovannucci EL, Meyerhardt JA, Schernhammer ES, Curhan GC and Fuchs CS (2005) Long-term use of aspirin and nonsteroidal anti-inflammatory drugs and risk of colorectal cancer. *JAMA*294:914-923.
- Chang C-R and Blackstone C (2007) Cyclic AMP-dependent Protein Kinase Phosphorylation of Drp1 Regulates Its GTPase Activity and Mitochondrial Morphology. *J Biol Chem*282:21583-21587.
- Chen L, Marquardt ML, Tester DJ, Sampson KJ, Ackerman MJ and Kass RS (2007) Mutation of an A-kinase-anchoring protein causes long-QT syndrome. *Proc Natl Acad Sci U S A*104:20990-20995.
- Chen Y-Z, Friedman JR, Chen D-H, Chan GC-K, Bloss CS, Hisama FM, Topol SE, Carson AR, Pham PH, Bonkowski ES, Scott ER, Lee JK, Zhang G, Oliveira G, Xu J, Scott-Van Zeeland AA, Chen Q, Levy S, Topol EJ, Storm D, Swanson PD, Bird TD, Schork NJ, Raskind WH and Torkamani A (2014) Gain-of-function ADCY5 mutations in familial dyskinesia with facial myokymia. *Ann Neurol*75:542-549.
- Cheng HC, van Patten SM, Smith AJ and Walsh DA (1985) An active twenty-amino-acid-residue peptide derived from the inhibitor protein of the cyclic AMP-dependent protein kinase. *Biochem J*231:655-661.
- Chepurny OG, Bertinetti D, Diskar M, Leech CA, Afshari P, Tsalkova T, Cheng X, Schwede F, Genieser HG, Herberg FW and Holz GG (2013) Stimulation of proglucagon gene expression by human GPR119 in enteroendocrine L-cell line GLUTag. *Mol Endocrinol*27:1267-1282.
- Cheung J, Ginter C, Cassidy M, Franklin MC, Rudolph MJ, Robine N, Darnell RB and Hendrickson WA (2015) Structural insights into mis-regulation of protein kinase A in human tumors. *Proc Natl Acad Sci U S A*112:1374-1379.

- Chijiwa T, Mishima A, Hagiwara M, Sano M, Hayashi K, Inoue T, Naito K, Toshioka T and Hidaka H (1990) Inhibition of forskolin-induced neurite outgrowth and protein phosphorylation by a newly synthesized selective inhibitor of cyclic AMP-dependent protein kinase, N-[2-(p-bromocinnamylamino)ethyl]-5-isoquinolinesulfonamide (H-89), of PC12D pheochromocytoma cells. *J Biol Chem*265:5267-5272.
- Chin S, Hung M and Bear CE (2017) Current insights into the role of PKA phosphorylation in CFTR channel activity and the pharmacological rescue of cystic fibrosis disease-causing mutants. *Cell Mol Life Sci*74:57-66.
- Christensen AE, Selheim F, de Rooij J, Dremier S, Schwede F, Dao KK, Martinez A, Maenhaut C, Bos JL, Genieser HG and Døskeland SO (2003) cAMP analog mapping of Epac1 and cAMP kinase. Discriminating analogs demonstrate that Epac and cAMP kinase act synergistically to promote PC-12 cell neurite extension. *J Biol Chem*278:35394-35402.
- Chubak J, Kamineni A, Buist DSM, Anderson ML and Whitlock EP (2015) U.S. Preventive Services Task Force Evidence Syntheses, formerly Systematic Evidence Reviews, in Aspirin Use for the Prevention of Colorectal Cancer: An Updated Systematic Evidence Review for the US Preventive Services Task Force, Agency for Healthcare Research and Quality (US), Rockville (MD).
- Clevers H (2013) The Intestinal Crypt, A Prototype Stem Cell Compartment. *Cell*154:274-284.
- Colao A, De Block C, Gaztambide MS, Kumar S, Seufert J and Casanueva FF (2014) Managing hyperglycemia in patients with Cushing's disease treated with pasireotide: medical expert recommendations. *Pituitary*17:180-186.
- Coles GL, Cristea S, Webber JT, Levin RS, Moss SM, He A, Sangodkar J, Hwang YC, Arand J, Drainas AP, Mooney NA, Demeter J, Spradlin JN, Mauch B, Le V, Shue YT, Ko JH, Lee MC, Kong C, Nomura DK, Ohlmeyer M, Swaney DL, Krogan NJ, Jackson PK, Narla G, Gordan JD, Shokat KM and Sage J (2020) Unbiased Proteomic Profiling Uncovers a Targetable GNAS/PKA/PP2A Axis in Small Cell Lung Cancer Stem Cells. *Cancer Cell*38:129-143.e127.
- Conway AE, Van Nostrand EL, Pratt GA, Aigner S, Wilbert ML, Sundararaman B, Freese P, Lambert NJ, Sathe S, Liang TY, Essex A, Landais S, Burge CB, Jones DL and Yeo GW (2016) Enhanced CLIP Uncovers IMP Protein-RNA Targets in Human Pluripotent Stem Cells Important for Cell Adhesion and Survival. *Cell Rep*15:666-679.
- Cook S and McCormick F (1993) Inhibition by cAMP of Ras-dependent activation of Raf. *Science*262:1069-1072.
- Cornella H, Alsinet C, Sayols S, Zhang Z, Hao K, Cabellos L, Hoshida Y, Villanueva A, Thung S, Ward SC, Rodriguez-Carunchio L, Vila-Casadesús M, Imbeaud S, Lachenmayer A, Quaglia A, Nagorney DM, Minguez B, Carrilho F, Roberts LR, Waxman S, Mazzaferro V, Schwartz M, Esteller M, Heaton ND, Zucman-Rossi J and Llovet JM (2015) Unique genomic profile of fibrolamellar hepatocellular carcinoma. *Gastroenterology*148:806-818.e810.
- Correa R, Salpea P and Stratakis CA (2015) Carney complex: an update. *Eur J Endocrinol*173:M85-97.

- Dagda RK and Das Banerjee T (2015) Role of protein kinase A in regulating mitochondrial function and neuronal development: implications to neurodegenerative diseases. *Rev Neurosci*26:359-370.
- Dani C, Blanchard JM, Piechaczyk M, El Sabouty S, Marty L and Jeanteur P (1984) Extreme instability of myc mRNA in normal and transformed human cells. *Proc Natl Acad Sci U S A*81:7046-7050.
- Dash PK, Hochner B and Kandel ER (1990) Injection of the cAMP-responsive element into the nucleus of Aplysia sensory neurons blocks long-term facilitation. *Nature*345:718-721.
- De Leo S, Lee SY and Braverman LE (2016) Hyperthyroidism. *Lancet*388:906-918.
- De Venanzi A, Alencar GA, Bourdeau I, Fragoso MC and Lacroix A (2014) Primary bilateral macronodular adrenal hyperplasia. *Curr Opin Endocrinol Diabetes Obes*21:177-184.
- Deeble PD, Cox ME, Frierson HF, Sikes RA, Palmer JB, Davidson RJ, Casarez EV, Amorino GP and Parsons SJ (2007) Androgen-Independent Growth and Tumorigenesis of Prostate Cancer Cells Are Enhanced by the Presence of PKA-Differentiated Neuroendocrine Cells. *Cancer Res*67:3663-3672.
- Dema A, Schröter MF, Perets E, Skroblin P, Moutty MC, Deak VA, Birchmeier W and Klussmann E (2016) The A-Kinase Anchoring Protein (AKAP) Glycogen Synthase Kinase 3 β Interaction Protein (GSKIP) Regulates β -Catenin through Its Interactions with Both Protein Kinase A and GSK3 β . *J Biol Chem*291:19618-19630.
- Dempster JM, Rossen J, Kazachkova M, Pan J, Kugener G, Root DE and Tsherniak A (2019) Extracting Biological Insights from the Project Achilles Genome-Scale CRISPR Screens in Cancer Cell Lines. *bioRxiv*:720243.
- DeNinno MP (2012) Future directions in phosphodiesterase drug discovery. *Bioorg Med Chem Lett*22:6794-6800.
- Devaiah BN, Case-Borden C, Gegonne A, Hsu CH, Chen Q, Meerzaman D, Dey A, Ozato K and Singer DS (2016) BRD4 is a histone acetyltransferase that evicts nucleosomes from chromatin. *Nat Struct Mol Biol*23:540-548.
- DeVita VT and Chu E (2008) A History of Cancer Chemotherapy. *Cancer Res*68:8643-8653.
- Dhillon AS, Pollock C, Steen H, Shaw PE, Mischak H and Kolch W (2002) Cyclic AMP-Dependent Kinase Regulates Raf-1 Kinase Mainly by Phosphorylation of Serine 259. *Mol Cell Biol*22:3237-3246.
- Di Benedetto G, Gerbino A and Lefkimiatis K (2018) Shaping mitochondrial dynamics: The role of cAMP signalling. *Biochem Biophys Res Commun*500:65-74.
- Di Vito A, Mignogna C and Donato G (2015) The mysterious pathways of cardiac myxomas: a review of histogenesis, pathogenesis and pathology. *Histopathology*66:321-332.

- Dilly AK, Honick BD, Lee YJ, Guo ZS, Zeh HJ, Bartlett DL and Choudry HA (2017) Targeting G-protein coupled receptor-related signaling pathway in a murine xenograft model of appendiceal pseudomyxoma peritonei. *Oncotarget*8:106888-106900.
- Dominissini D, Moshitch-Moshkovitz S, Schwartz S, Salmon-Divon M, Ungar L, Osenberg S, Cesarkas K, Jacob-Hirsch J, Amariglio N, Kupiec M, Sorek R and Rechavi G (2012) Topology of the human and mouse m6A RNA methylomes revealed by m6A-seq. *Nature*485:201-206.
- Doncheva NT, Morris JH, Gorodkin J and Jensen LJ (2019) Cytoscape StringApp: Network Analysis and Visualization of Proteomics Data. *J Proteome Res*18:623-632.
- Dorsam RT and Gutkind JS (2007) G-protein-coupled receptors and cancer. *Nat Rev Cancer*7:79-94.
- Drew DA, Cao Y and Chan AT (2016) Aspirin and colorectal cancer: the promise of precision chemoprevention. *Nat Rev Cancer*16:173-186.
- Drost J, van Jaarsveld RH, Ponsioen B, Zimmerlin C, van Boxtel R, Buijs A, Sachs N, Overmeer RM, Offerhaus GJ, Begthel H, Korving J, van de Wetering M, Schwank G, Logtenberg M, Cuppen E, Snippert HJ, Medema JP, Kops GJPL and Clevers H (2015) Sequential cancer mutations in cultured human intestinal stem cells. *Nature*521:43-47.
- Druker BJ, Sawyers CL, Kantarjian H, Resta DJ, Reese SF, Ford JM, Capdeville R and Talpaz M (2001) Activity of a specific inhibitor of the BCR-ABL tyrosine kinase in the blast crisis of chronic myeloid leukemia and acute lymphoblastic leukemia with the Philadelphia chromosome. *N Engl J Med*344:1038-1042.
- Dumaz N, Hayward R, Martin J, Ogilvie L, Hedley D, Curtin JA, Bastian BC, Springer C and Marais R (2006) In Melanoma, RAS Mutations Are Accompanied by Switching Signaling from BRAF to CRAF and Disrupted Cyclic AMP Signaling. *Cancer Res*66:9483-9491.
- Durick K, Wu RY, Gill GN and Taylor SS (1996) Mitogenic signaling by Ret/ptc2 requires association with enigma via a LIM domain. *J Biol Chem*271:12691-12694.
- Durick K, Yao VJ, Borrello MG, Bongarzone I, Pierotti MA and Taylor SS (1995) Tyrosines outside the kinase core and dimerization are required for the mitogenic activity of RET/ptc2. *J Biol Chem*270:24642-24645.
- Dyson MT, Kowalewski MP, Manna PR and Stocco DM (2009) The differential regulation of steroidogenic acute regulatory protein-mediated steroidogenesis by type I and type II PKA in MA-10 cells. *Mol Cell Endocrinol*300:94-103.
- Eichholtz T, de Bont DB, de Widt J, Liskamp RM and Ploegh HL (1993) A myristoylated pseudosubstrate peptide, a novel protein kinase C inhibitor. *J Biol Chem*268:1982-1986.
- Engh RA, Girod A, Kinzel V, Huber R and Bossemeyer D (1996) Crystal structures of catalytic subunit of cAMP-dependent protein kinase in complex with isoquinolinesulfonyl protein kinase inhibitors H7, H8, and H89. Structural implications for selectivity. *J Biol Chem*271:26157-26164.

- Enkvist E, Lavogina D, Raidaru G, Vaasa A, Viil I, Lust M, Viht K and Uri A (2006) Conjugation of adenosine and hexa-(D-arginine) leads to a nanomolar bisubstrate-analog inhibitor of basophilic protein kinases. *J Med Chem*49:7150-7159.
- Enkvist E, Raidaru G, Vaasa A, Pehk T, Lavogina D and Uri A (2007) Carbocyclic 3'-deoxyadenosine-based highly potent bisubstrate-analog inhibitor of basophilic protein kinases. *Bioorg Med Chem Lett*17:5336-5339.
- Ercu M, Markó L, Schächterle C, Tsvetkov D, Cui Y, Maghsodi S, Bartolomaeus TUP, Maass PG, Zühlke K, Gregersen N, Hübner N, Hodge R, Mühl A, Pohl B, Illas RM, Geelhaar A, Walter S, Napieczynska H, Schelenz S, Taube M, Heuser A, Anistan YM, Qadri F, Todiras M, Plehm R, Popova E, Langanki R, Eichhorst J, Lehmann M, Wiesner B, Russwurm M, Forslund SK, Kamer I, Müller DN, Gollasch M, Aydin A, Bähring S, Bader M, Luft FC and Klussmann E (2020) Phosphodiesterase 3A and Arterial Hypertension. *Circulation*142:133-149.
- Erion DM, Ignatova ID, Yonemitsu S, Nagai Y, Chatterjee P, Weismann D, Hsiao JJ, Zhang D, Iwasaki T, Stark R, Flannery C, Kahn M, Carmean CM, Yu XX, Murray SF, Bhanot S, Monia BP, Cline GW, Samuel VT and Shulman GI (2009) Prevention of hepatic steatosis and hepatic insulin resistance by knockdown of cAMP response element-binding protein. *Cell Metab*10:499-506.
- Espiard S, Knape MJ, Bathon K, Assié G, Rizk-Rabin M, Faillot S, Luscap-Rondof W, Abid D, Guignat L, Calebiro D, Herberg FW, Stratakis CA and Bertherat J (2018) Activating PRKACB somatic mutation in cortisol-producing adenomas. *JCI Insight*3.
- Facchinetti F, Bluthgen MV, Tergemina-Clain G, Faivre L, Pignon JP, Planchard D, Remon J, Soria JC, Lacroix L and Besse B (2017) LKB1/STK11 mutations in non-small cell lung cancer patients: Descriptive analysis and prognostic value. *Lung Cancer*112:62-68.
- Fan XC and Steitz JA (1998) Overexpression of HuR, a nuclear-cytoplasmic shuttling protein, increases the in vivo stability of ARE-containing mRNAs. *EMBO J*17:3448-3460.
- Fang X, Yu SX, Lu Y, Bast RC, Woodgett JR and Mills GB (2000) Phosphorylation and inactivation of glycogen synthase kinase 3 by protein kinase A. *Proc Natl Acad Sci U S A*97:11960-11965.
- Farquhar MJ, Harris HJ, Diskar M, Jones S, Mee CJ, Nielsen SU, Brimacombe CL, Molina S, Toms GL, Maurel P, Howl J, Herberg FW, van Ijzendoorn SC, Balfe P and McKeating JA (2008) Protein kinase A-dependent step(s) in hepatitis C virus entry and infectivity. *J Virol*82:8797-8811.
- Fearon ER and Vogelstein B (1990) A genetic model for colorectal tumorigenesis. *Cell*61:759-767.
- Feller L, Wood NH, Khammissa RAG, Lemmer J and Raubenheimer EJ (2009) The nature of fibrous dysplasia. *Head Face Med*5:22-22.
- Feng X, Arang N, Rigracciolo DC, Lee JS, Yeerna H, Wang Z, Lubrano S, Kishore A, Pachter JA, König GM, Maggiolini M, Kostenis E, Schlaepfer DD, Tamayo P, Chen Q, Ruppin E and Gutkind JS (2019) A Platform of Synthetic Lethal Gene Interaction Networks Reveals

- that the GNAQ Uveal Melanoma Oncogene Controls the Hippo Pathway through FAK. *Cancer Cell*35:457-472 e455.
- Feng Y, Sentani K, Wiese A, Sands E, Green M, Bommer GT, Cho KR and Fearon ER (2013) Sox9 induction, ectopic Paneth cells, and mitotic spindle axis defects in mouse colon adenomatous epithelium arising from conditional biallelic Apc inactivation. *The American journal of pathology*183:493-503.
- Forlino A, Vetro A, Garavelli L, Ciccone R, London E, Stratakis CA and Zuffardi O (2014) PRKACB and Carney Complex. *N Engl J Med*370:1065-1067.
- Fragoso M, Domenice S, Latronico A, Martin R, Pereira M, Zerbini M, Lucon A and Mendonca B (2003) Cushing's syndrome secondary to adrenocorticotropin-independent macronodular adrenocortical hyperplasia due to activating mutations of GNAS1 gene. *J Clin Endocrinol Metab*88:2147-2151.
- Freda PU (2002) Somatostatin Analogs in Acromegaly. *J Clin Endocrinol Metab*87:3013-3018.
- Freda PU, Chung WK, Matsuoka N, Walsh JE, Kanibir MN, Kleinman G, Wang Y, Bruce JN and Post KD (2007) Analysis of GNAS mutations in 60 growth hormone secreting pituitary tumors: correlation with clinical and pathological characteristics and surgical outcome based on highly sensitive GH and IGF-I criteria for remission. *Pituitary*10:275-282.
- Frese KK and Tuveson DA (2007) Maximizing mouse cancer models. *Nature Reviews Cancer*7:654-658.
- Gadella MR, Kasuki L and Korbonits M (2017) The genetic background of acromegaly. *Pituitary*20:10-21.
- Gao H, Sun X and Rao Y (2020) PROTAC Technology: Opportunities and Challenges. *ACS Med Chem Lett*11:237-240.
- Gao J, Aksoy BA, Dogrusoz U, Dresdner G, Gross B, Sumer SO, Sun Y, Jacobsen A, Sinha R, Larsson E, Cerami E, Sander C and Schultz N (2013) Integrative analysis of complex cancer genomics and clinical profiles using the cBioPortal. *Sci Signal*6:pl1.
- García-Mauriño SM, Rivero-Rodríguez F, Velázquez-Cruz A, Hernández-Vellisca M, Díaz-Quintana A, De la Rosa MA and Díaz-Moreno I (2017) RNA Binding Protein Regulation and Cross-Talk in the Control of AU-rich mRNA Fate. *Frontiers in Molecular Biosciences*4.
- Gassler N (2017) Paneth cells in intestinal physiology and pathophysiology. *World J Gastrointest Pathophysiol*8:150-160.
- Gebauer F, Schwarzl T, Valcárcel J and Hentze MW (2021) RNA-binding proteins in human genetic disease. *Nature Reviews Genetics*22:185-198.
- Gelsi-Boyer V, Brecqueville M, Devillier R, Murati A, Mozziconacci M-J and Birnbaum D (2012) Mutations in ASXL1 are associated with poor prognosis across the spectrum of malignant myeloid diseases. *J Hematol Oncol*5:12.

- Ghandi M, Huang FW, Jané-Valbuena J, Kryukov GV, Lo CC, McDonald ER, Barretina J, Gelfand ET, Bielski CM, Li H, Hu K, Andreev-Drakhlin AY, Kim J, Hess JM, Haas BJ, Aguet F, Weir BA, Rothberg MV, Paoletta BR, Lawrence MS, Akbani R, Lu Y, Tiv HL, Gokhale PC, de Weck A, Mansour AA, Oh C, Shih J, Hadi K, Rosen Y, Bistline J, Venkatesan K, Reddy A, Sonkin D, Liu M, Lehar J, Korn JM, Porter DA, Jones MD, Golji J, Caponigro G, Taylor JE, Dunning CM, Creech AL, Warren AC, McFarland JM, Zamanighomi M, Kauffmann A, Stransky N, Imielinski M, Maruvka YE, Cherniack AD, Tsherniak A, Vazquez F, Jaffe JD, Lane AA, Weinstock DM, Johannessen CM, Morrissey MP, Stegmeier F, Schlegel R, Hahn WC, Getz G, Mills GB, Boehm JS, Golub TR, Garraway LA and Sellers WR (2019) Next-generation characterization of the Cancer Cell Line Encyclopedia. *Nature*569:503-508.
- Giardiello FM, Hamilton SR, Krush AJ, Piantadosi S, Hylind LM, Celano P, Booker SV, Robinson CR and Offerhaus GJ (1993) Treatment of colonic and rectal adenomas with sulindac in familial adenomatous polyposis. *N Engl J Med*328:1313-1316.
- Giunta EF, De Falco V, Napolitano S, Argenziano G, Brancaccio G, Moscarella E, Ciardiello D, Ciardiello F and Troiani T (2020) Optimal treatment strategy for metastatic melanoma patients harboring BRAF-V600 mutations. *Ther Adv Med Oncol*12:1758835920925219.
- Giurgiu M, Reinhard J, Brauner B, Dunger-Kaltenbach I, Fobo G, Frishman G, Montrone C and Ruepp A (2019) CORUM: the comprehensive resource of mammalian protein complexes-2019. *Nucleic Acids Res*47:D559-d563.
- Gjertsen BT, Mellgren G, Otten A, Maronde E, Genieser HG, Jastorff B, Vintermyr OK, McKnight GS and Døskeland SO (1995) Novel (Rp)-cAMPS analogs as tools for inhibition of cAMP-kinase in cell culture. Basal cAMP-kinase activity modulates interleukin-1 beta action. *J Biol Chem*270:20599-20607.
- Gloerich M and Bos JL (2010) Epac: Defining a New Mechanism for cAMP Action. *Annu Rev Pharmacol Toxicol*50:355-375.
- Goel S, Desai K, Macapinlac M, Wadler S, Goldberg G, Fields A, Einstein M, Volterra F, Wong B, Martin R and Mani S (2006) A phase I safety and dose escalation trial of docetaxel combined with GEM231, a second generation antisense oligonucleotide targeting protein kinase A R1alpha in patients with advanced solid cancers. *Invest New Drugs*24:125-134.
- Goessling W, North TE, Loewer S, Lord AM, Lee S, Stoick-Cooper CL, Weidinger G, Puder M, Daley GQ, Moon RT and Zon LI (2009) Genetic interaction of PGE2 and Wnt signaling regulates developmental specification of stem cells and regeneration. *Cell*136:1136-1147.
- Goh G, Scholl UI, Healy JM, Choi M, Prasad ML, Nelson-Williams C, Kunstman JW, Korah R, Suttorp AC, Dietrich D, Haase M, Willenberg HS, Stålberg P, Hellman P, Akerström G, Björklund P, Carling T and Lifton RP (2014) Recurrent activating mutation in PRKACA in cortisol-producing adrenal tumors. *Nat Genet*46:613-617.
- Gold MG, Fowler DM, Means CK, Pawson CT, Stephany JJ, Langeberg LK, Fields S and Scott JD (2013) Engineering A-kinase anchoring protein (AKAP)-selective regulatory subunits of protein kinase A (PKA) through structure-based phage selection. *J Biol Chem*288:17111-17121.

- Goodman BE and Percy WH (2005) CFTR in cystic fibrosis and cholera: from membrane transport to clinical practice. *Adv Physiol Educ*29:75-82.
- Graham RP, Lackner C, Terracciano L, González-Cantú Y, Maleszewski JJ, Greipp PT, Simon SM and Torbenson MS (2018) Fibrolamellar carcinoma in the Carney complex: PRKAR1A loss instead of the classic DNAJB1-PRKACA fusion. *Hepatology*68:1441-1447.
- Greene EL, Horvath AD, Nesterova M, Giatzakis C, Bossis I and Stratakis CA (2008) In vitro functional studies of naturally occurring pathogenic PRKAR1A mutations that are not subject to nonsense mRNA decay. *Hum Mutat*29:633-639.
- Greenwald EC and Saucerman JJ (2011) Bigger, better, faster: principles and models of AKAP anchoring protein signaling. *J Cardiovasc Pharmacol*58:462-469.
- Greggio E, Bubacco L and Russo I (2017) Cross-talk between LRRK2 and PKA: implication for Parkinson's disease? *Biochem Soc Trans*45:261-267.
- Gu C, Shi X, Dai C, Shen F, Rocco G, Chen J, Huang Z, Chen C, He C, Huang T and Chen C (2020) RNA m6A Modification in Cancers: Molecular Mechanisms and Potential Clinical Applications. *The Innovation*1:100066.
- Gu L, Lau SK, Loera S, Somlo G and Kane SE (2009) Protein Kinase A Activation Confers Resistance to Trastuzumab in Human Breast Cancer Cell Lines. *Clin Cancer Res*15:7196-7206.
- Hage M, Viengchareun S, Brunet E, Villa C, Pineau D, Bouligand J, Teglas JP, Adam C, Parker F, Lombès M, Tachdjian G, Gaillard S, Chanson P, Tosca L and Kamenický P (2018) Genomic Alterations and Complex Subclonal Architecture in Sporadic GH-Secreting Pituitary Adenomas. *J Clin Endocrinol Metab*103:1929-1939.
- Hagiwara M, Brindle P, Harootunian A, Armstrong R, Rivier J, Vale W, Tsien R and Montminy MR (1993) Coupling of hormonal stimulation and transcription via the cyclic AMP-responsive factor CREB is rate limited by nuclear entry of protein kinase A. *Mol Cell Biol*13:4852-4859.
- Halls ML and Cooper DMF (2017) Adenylyl cyclase signalling complexes - Pharmacological challenges and opportunities. *Pharmacol Ther*172:171-180.
- Ham J, Ivan M, Wynford-Thomas D and Scanlon MF (1997) GH3 cells expressing constitutively active Gs alpha (Q227L) show enhanced hormone secretion and proliferation. *Mol Cell Endocrinol*127:41-47.
- Hamada T, Cao Y, Qian ZR, Masugi Y, Nowak JA, Yang J, Song M, Mima K, Kosumi K, Liu L, Shi Y, da Silva A, Gu M, Li W, Keum N, Zhang X, Wu K, Meyerhardt JA, Giovannucci EL, Giannakis M, Rodig SJ, Freeman GJ, Nevo D, Wang M, Chan AT, Fuchs CS, Nishihara R and Ogino S (2017) Aspirin Use and Colorectal Cancer Survival According to Tumor CD274 (Programmed Cell Death 1 Ligand 1) Expression Status. *J Clin Oncol*35:1836-1844.
- Hammarsjö A, Pettersson M, Chitayat D, Handa A, Anderlid B-M, Bartocci M, Basel D, Batkovskytte D, Beleza-Meireles A, Conner P, Eisfeldt J, Girisha KM, Chung BH-Y,

- Horemuzova E, Hyodo H, Korņejeva L, Lagerstedt-Robinson K, Lin AE, Magnusson M, Moosa S, Nayak SS, Nilsson D, Ohashi H, Ohashi-Fukuda N, Stranneheim H, Taylan F, Traberg R, Voss U, Wirta V, Nordgren A, Nishimura G, Lindstrand A and Grigelioniene G (2021) High diagnostic yield in skeletal ciliopathies using massively parallel genome sequencing, structural variant screening and RNA analyses. *J Hum Genet*.
- Hamuro Y, Anand GS, Kim JS, Juliano C, Stranz DD, Taylor SS and Woods VL (2004) Mapping Intersubunit Interactions of the Regulatory Subunit (RI α) in the Type I Holoenzyme of Protein Kinase A by Amide Hydrogen/Deuterium Exchange Mass Spectrometry (DXMS). *J Mol Biol*340:1185-1196.
- Han H-S, Kang G, Kim JS, Choi BH and Koo S-H (2016) Regulation of glucose metabolism from a liver-centric perspective. *Exp Mol Med*48:e218-e218.
- Han SH and Choe J (2020) Diverse molecular functions of m6A mRNA modification in cancer. *Exp Mol Med*52:738-749.
- Hanahan D and Weinberg RA (2000) The Hallmarks of Cancer. *Cell*100:57-70.
- Hand AR and Jungmann RA (1989) Localization of cellular regulatory proteins using postembedding immunogold labeling. *Am J Anat*185:183-196.
- Hanke SE, Bertinetti D, Badel A, Schweinsberg S, Genieser HG and Herberg FW (2011) Cyclic nucleotides as affinity tools: phosphorothioate cAMP analogues address specific PKA subproteomes. *N Biotechnol*28:294-301.
- Hanks SK and Hunter T (1995) Protein kinases 6. The eukaryotic protein kinase superfamily: kinase (catalytic) domain structure and classification. *FASEB J*9:576-596.
- Hannah-Shmouni F, Trivellin G and Stratakis CA (2016) Genetics of gigantism and acromegaly. *Growth Horm IGF Res*30-31:37-41.
- Hanoune J and Defer N (2001) Regulation and Role of Adenylyl Cyclase Isoforms. *Annu Rev Pharmacol Toxicol*41:145-174.
- Hansen-Petrik MB, McEntee MF, Jull B, Shi H, Zemel MB and Whelan J (2002) Prostaglandin E(2) protects intestinal tumors from nonsteroidal anti-inflammatory drug-induced regression in Apc(Min/+) mice. *Cancer Res*62:403-408.
- Hata AN and Breyer RM (2004) Pharmacology and signaling of prostaglandin receptors: multiple roles in inflammation and immune modulation. *Pharmacol Ther*103:147-166.
- Hata T, Mizuma M, Motoi F, Omori Y, Ishida M, Nakagawa K, Hayashi H, Morikawa T, Kamei T, Furukawa T and Unno M (2020) GNAS mutation detection in circulating cell-free DNA is a specific predictor for intraductal papillary mucinous neoplasms of the pancreas, especially for intestinal subtype. *Sci Rep*10:17761.
- He J, Sun M, Li E, Hou Y, Shepard MJ, Chen D, Pacak K, Wang C, Guo L, Zhuang Z and Liu Y (2017) Recurrent somatic mutations of PRKAR1A in isolated cardiac myxoma. *Oncotarget*8:103968-103974.

- He L, Li H, Wu A, Peng Y, Shu G and Yin G (2019) Functions of N6-methyladenosine and its role in cancer. *Mol Cancer*18:176.
- He X, Zhang L, Chen Y, Remke M, Shih D, Lu F, Wang H, Deng Y, Yu Y, Xia Y, Wu X, Ramaswamy V, Hu T, Wang F, Zhou W, Burns DK, Kim SH, Kool M, Pfister SM, Weinstein LS, Pomeroy SL, Gilbertson RJ, Rubin JB, Hou Y, Wechsler-Reya R, Taylor MD and Lu QR (2014) The G protein α subunit Gas is a tumor suppressor in Sonic hedgehog-driven medulloblastoma. *Nat Med*20:1035-1042.
- Hébrant A, van Staveren WC, Maenhaut C, Dumont JE and Leclère J (2011) Genetic hyperthyroidism: hyperthyroidism due to activating TSHR mutations. *Eur J Endocrinol*164:1-9.
- Herberg FW and Taylor SS (1993) Physiological inhibitors of the catalytic subunit of cAMP-dependent protein kinase: effect of MgATP on protein-protein interactions. *Biochemistry*32:14015-14022.
- Herberg FW, Doyle ML, Cox S and Taylor SS (1999) Dissection of the Nucleotide and Metal-Phosphate Binding Sites in cAMP-Dependent Protein Kinase. *Biochemistry*38:6352-6360.
- Herberg FW, Maleszka A, Eide T, Vossebein L and Tasken K (2000) Analysis of A-kinase anchoring protein (AKAP) interaction with protein kinase A (PKA) regulatory subunits: PKA isoform specificity in AKAP binding. *J Mol Biol*298:329-339.
- Herter-Sprue GS, Kung AL and Wong KK (2013) New cast for a new era: preclinical cancer drug development revisited. *J Clin Invest*123:3639-3645.
- Hida T, Yatabe Y, Achiwa H, Muramatsu H, Kozaki K, Nakamura S, Ogawa M, Mitsudomi T, Sugiura T and Takahashi T (1998) Increased expression of cyclooxygenase 2 occurs frequently in human lung cancers, specifically in adenocarcinomas. *Cancer Res*58:3761-3764.
- Hidaka H, Inagaki M, Kawamoto S and Sasaki Y (1984) Isoquinolinesulfonamides, novel and potent inhibitors of cyclic nucleotide dependent protein kinase and protein kinase C. *Biochemistry*23:5036-5041.
- Hino S, Tanji C, Nakayama KI and Kikuchi A (2005) Phosphorylation of beta-catenin by cyclic AMP-dependent protein kinase stabilizes beta-catenin through inhibition of its ubiquitination. *Mol Cell Biol*25:9063-9072.
- Hiroi N, Yakushiji F, Shimojo M, Watanabe S, Sugano S, Yamaguchi N and Miyachi Y (1998) Human ACTH hypersensitivity syndrome associated with abnormalities of the ACTH receptor gene. *Clin Endocrinol (Oxf)*48:129-134.
- Hodson R (2016) Precision medicine. *Nature*537:S49-S49.
- Hollingsworth MA and Swanson BJ (2004) Mucins in cancer: protection and control of the cell surface. *Nat Rev Cancer*4:45-60.

- Holz GG, Chepurny OG and Schwede F (2008) Epac-selective cAMP analogs: new tools with which to evaluate the signal transduction properties of cAMP-regulated guanine nucleotide exchange factors. *Cell Signal*20:10-20.
- Honeyman JN, Simon EP, Robine N, Chiaroni-Clarke R, Darcy DG, Lim, II, Gleason CE, Murphy JM, Rosenberg BR, Teegan L, Takacs CN, Botero S, Belote R, Germer S, Emde AK, Vacic V, Bhanot U, LaQuaglia MP and Simon SM (2014) Detection of a recurrent DNAJB1-PRKACA chimeric transcript in fibrolamellar hepatocellular carcinoma. *Science*343:1010-1014.
- Horvath A, Bertherat J, Groussin L, Guillaud-Bataille M, Tsang K, Cazabat L, Libé R, Remmers E, René-Corail F, Faucz FR, Clauser E, Calender A, Bertagna X, Carney JA and Stratakis CA (2010) Mutations and polymorphisms in the gene encoding regulatory subunit type 1- α of protein kinase A (PRKAR1A): an update. *Hum Mutat*31:369-379.
- Horvath A, Bossis I, Giatzakis C, Levine E, Weinberg F, Meoli E, Robinson-White A, Siegel J, Soni P, Groussin L, Matyakhina L, Verma S, Remmers E, Nesterova M, Carney JA, Bertherat J and Stratakis CA (2008) Large deletions of the PRKAR1A gene in Carney complex. *Clin Cancer Res*14:388-395.
- Houslay MD and Adams DR (2003) PDE4 cAMP phosphodiesterases: modular enzymes that orchestrate signalling cross-talk, desensitization and compartmentalization. *Biochem J*370:1-18.
- Howe AK (2004) Regulation of actin-based cell migration by cAMP/PKA. *Biochim Biophys Acta*1692:159-174.
- Hsiao H, Kirschner L, Bourdeau I, Keil M, Boikos S, Verma S, Robinson-White A, Nesterova M, Lacroix A and Stratakis C (2009) Clinical and genetic heterogeneity, overlap with other tumor syndromes, and atypical glucocorticoid hormone secretion in adrenocorticotropin-independent macronodular adrenal hyperplasia compared with other adrenocortical tumors. *J Clin Endocrinol Metab*94:2930-2937.
- Hu Q and Shokat KM (2018) Disease-Causing Mutations in the G Protein α Subunit Subvert the Roles of GDP and GTP. *Cell*173:1254-1264 e1211.
- Huang H, Weng H, Sun W, Qin X, Shi H, Wu H, Zhao BS, Mesquita A, Liu C, Yuan CL, Hu Y-C, Hüttelmaier S, Skibbe JR, Su R, Deng X, Dong L, Sun M, Li C, Nachtergaele S, Wang Y, Hu C, Ferchen K, Greis KD, Jiang X, Wei M, Qu L, Guan J-L, He C, Yang J and Chen J (2018) Recognition of RNA N(6)-methyladenosine by IGF2BP proteins enhances mRNA stability and translation. *Nat Cell Biol*20:285-295.
- Huang LJ, Wang L, Ma Y, Durick K, Perkins G, Deerinck TJ, Ellisman MH and Taylor SS (1999) NH₂-Terminal targeting motifs direct dual specificity A-kinase-anchoring protein 1 (D-AKAP1) to either mitochondria or endoplasmic reticulum. *J Cell Biol*145:951-959.
- Huang Y, Roelink H and McKnight GS (2002) Protein kinase A deficiency causes axially localized neural tube defects in mice. *J Biol Chem*277:19889-19896.
- Huang Y, Su R, Sheng Y, Dong L, Dong Z, Xu H, Ni T, Zhang ZS, Zhang T, Li C, Han L, Zhu Z, Lian F, Wei J, Deng Q, Wang Y, Wunderlich M, Gao Z, Pan G, Zhong D, Zhou H, Zhang

- N, Gan J, Jiang H, Mulloy JC, Qian Z, Chen J and Yang CG (2019) Small-Molecule Targeting of Oncogenic FTO Demethylase in Acute Myeloid Leukemia. *Cancer Cell*35:677-691.e610.
- Huff S, Tiwari SK, Gonzalez GM, Wang Y and Rana TM (2021) m(6)A-RNA Demethylase FTO Inhibitors Impair Self-Renewal in Glioblastoma Stem Cells. *ACS Chem Biol*16:324-333.
- Huh JY, Kwon MJ, Seo KY, Kim MK, Chae KY, Kim SH, Ki CS, Yoon MS and Kim DH (2014) Novel nonsense GNAS mutation in a 14-month-old boy with plate-like osteoma cutis and medulloblastoma. *J Dermatol*41:319-321.
- Huttlin EL, Bruckner RJ, Navarrete-Perea J, Cannon JR, Baltier K, Gebreab F, Gygi MP, Thornock A, Zarraga G, Tam S, Szpyt J, Gassaway BM, Panov A, Parzen H, Fu S, Golbazi A, Maenpaa E, Stricker K, Guha Thakurta S, Zhang T, Rad R, Pan J, Nusinow DP, Paulo JA, Schweppe DK, Vaites LP, Harper JW and Gygi SP (2021) Dual proteome-scale networks reveal cell-specific remodeling of the human interactome. *Cell*.
- Iacovazzo D and Korbonits M (2016) Gigantism: X-linked acrogigantism and GPR101 mutations. *Growth Horm IGF Res*30-31:64-69.
- Ideno N, Ohtsuka T, Kono H, Fujiwara K, Oda Y, Aishima S, Ito T, Ishigami K, Tokunaga S, Ohuchida K, Takahata S, Nakamura M, Mizumoto K and Tanaka M (2013) Intraductal papillary mucinous neoplasms of the pancreas with distinct pancreatic ductal adenocarcinomas are frequently of gastric subtype. *Ann Surg*258:141-151.
- Ideno N, Yamaguchi H, Ghosh B, Gupta S, Okumura T, Steffen DJ, Fisher CG, Wood LD, Singhi AD, Nakamura M, Gutkind JS and Maitra A (2018) GNAS(R201C) Induces Pancreatic Cystic Neoplasms in Mice That Express Activated KRAS by Inhibiting YAP1 Signaling. *Gastroenterology*155:1593-1607 e1512.
- Ideno N, Yamaguchi H, Ghosh B, Gupta S, Okumura T, Steffen DJ, Fisher CG, Wood LD, Singhi AD, Nakamura M, Gutkind JS and Maitra A (2018) GNAS(R201C) Induces Pancreatic Cystic Neoplasms in Mice That Express Activated KRAS by Inhibiting YAP1 Signaling. *Gastroenterology*155:1593-1607 e1512.
- Iglesias-Bartolome R, Torres D, Marone R, Feng X, Martin D, Simaan M, Chen M, Weinstein LS, Taylor SS, Molinolo AA and Gutkind JS (2015) Inactivation of a Galpha(s)-PKA tumour suppressor pathway in skin stem cells initiates basal-cell carcinogenesis. *Nat Cell Biol*17:793-803.
- Impey S, McCorkle SR, Cha-Molstad H, Dwyer JM, Yochum GS, Boss JM, McWeeney S, Dunn JJ, Mandel G and Goodman RH (2004) Defining the CREB Regulon: A Genome-Wide Analysis of Transcription Factor Regulatory Regions. *Cell*119:1041-1054.
- Innamorati G, Wilkie TM, Kantheti HS, Valenti MT, Dalle Carbonare L, Giacomello L, Parenti M, Melisi D and Bassi C (2018) The curious case of Gas gain-of-function in neoplasia. *BMC Cancer*18:293.
- Jackson EL, Willis N, Mercer K, Bronson RT, Crowley D, Montoya R, Jacks T and Tuveson DA (2001) Analysis of lung tumor initiation and progression using conditional expression of oncogenic K-ras. *Genes Dev*15:3243-3248.

- Javaid MK, Boyce A, Appelman-Dijkstra N, Ong J, Defabianis P, Offiah A, Arundel P, Shaw N, Pos VD, Underhil A, Portero D, Heral L, Heegaard A-M, Masi L, Monsell F, Stanton R, Dijkstra PDS, Brandi ML, Chapurlat R, Hamdy NAT and Collins MT (2019) Best practice management guidelines for fibrous dysplasia/McCune-Albright syndrome: a consensus statement from the FD/MAS international consortium. *Orphanet J Rare Dis*14:139-139.
- Jeong MJ, Kim EJ, Cho EA, Ye SK, Kang GH and Juhn YS (2013) cAMP signalling decreases p300 protein levels by promoting its ubiquitin/proteasome dependent degradation via Epac and p38 MAPK in lung cancer cells. *FEBS Lett*587:1373-1378.
- Jho E (2018) Dual role of YAP: oncoprotein and tumor suppressor. *J Thorac Dis*10:S3895-S3898.
- Johannessen CM, Johnson LA, Piccioni F, Townes A, Frederick DT, Donahue MK, Narayan R, Flaherty KT, Wargo JA, Root DE and Garraway LA (2013) A melanocyte lineage program confers resistance to MAP kinase pathway inhibition. *Nature*504:138-142.
- Johnson DA, Akamine P, Radzio-Andzelm E, Madhusudan M and Taylor SS (2001) Dynamics of cAMP-dependent protein kinase. *Chem Rev*101:2243-2270.
- Julius D and Nathans J (2012) Signaling by sensory receptors. *Cold Spring Harb Perspect Biol*4:a005991.
- Kaelin WG (2005) The concept of synthetic lethality in the context of anticancer therapy. *Nat Rev Cancer*5:689-698.
- Kajiyama H, Mizuno M, Shibata K, Kawai M, Nagasaka T and Kikkawa F (2014) Extremely poor postrecurrence oncological outcome for patients with recurrent mucinous ovarian cancer. *Int J Clin Oncol*19:121-126.
- Kakadia S, Yarlagadda N, Awad R, Kundranda M, Niu J, Naraev B, Mina L, Dragovich T, Gimbel M and Mahmoud F (2018) Mechanisms of resistance to BRAF and MEK inhibitors and clinical update of US Food and Drug Administration-approved targeted therapy in advanced melanoma. *Onco Targets Ther*11:7095-7107.
- Kamilaris CDC, Faucz FR, Voutetakis A and Stratakis CA (2019) Carney Complex. *Exp Clin Endocrinol Diabetes*127:156-164.
- Kan Z, Jaiswal BS, Stinson J, Janakiraman V, Bhatt D, Stern HM, Yue P, Haverty PM, Bourgon R, Zheng J, Moorhead M, Chaudhuri S, Tomsho LP, Peters BA, Pujara K, Cordes S, Davis DP, Carlton VE, Yuan W, Li L, Wang W, Eigenbrot C, Kaminker JS, Eberhard DA, Waring P, Schuster SC, Modrusan Z, Zhang Z, Stokoe D, de Sauvage FJ, Faham M and Seshagiri S (2010) Diverse somatic mutation patterns and pathway alterations in human cancers. *Nature*466:869-873.
- Kandel ER (2012) The molecular biology of memory: cAMP, PKA, CRE, CREB-1, CREB-2, and CPEB. *Mol Brain*5:14.
- Kaper JB, Morris JG, Jr. and Levine MM (1995) Cholera. *Clin Microbiol Rev*8:48-86.
- Kase H, Iwahashi K, Nakanishi S, Matsuda Y, Yamada K, Takahashi M, Murakata C, Sato A and Kaneko M (1987) K-252 compounds, novel and potent inhibitors of protein kinase C and

- cyclic nucleotide-dependent protein kinases. *Biochem Biophys Res Commun*142:436-440.
- Kasthuber ER, Lalazar G, Houlihan SL, Tschaharganeh DF, Baslan T, Chen CC, Requena D, Tian S, Bosbach B, Wilkinson JE, Simon SM and Lowe SW (2017) DNAJB1-PRKACA fusion kinase interacts with β -catenin and the liver regenerative response to drive fibrolamellar hepatocellular carcinoma. *Proc Natl Acad Sci U S A*114:13076-13084.
- Kaur S, Kumar S, Momi N, Sasson AR and Batra SK (2013) Mucins in pancreatic cancer and its microenvironment. *Nat Rev Gastroenterol Hepatol*10:607-620.
- Kawamori T, Uchiya N, Sugimura T and Wakabayashi K (2003) Enhancement of colon carcinogenesis by prostaglandin E2 administration. *Carcinogenesis*24:985-990.
- Kee BL, Arias J and Montminy MR (1996) Adaptor-mediated recruitment of RNA polymerase II to a signal-dependent activator. *J Biol Chem*271:2373-2375.
- Kemp BE, Graves DJ, Benjamini E and Krebs EG (1977) Role of multiple basic residues in determining the substrate specificity of cyclic AMP-dependent protein kinase. *J Biol Chem*252:4888-4894.
- Kennedy EJ and Scott JD (2015) Selective disruption of the AKAP signaling complexes. *Methods Mol Biol*1294:137-150.
- Khan SK, Yadav PS, Elliott G, Hu DZ, Xu R and Yang Y (2018) Induced Gnas(R201H) expression from the endogenous Gnas locus causes fibrous dysplasia by up-regulating Wnt/ β -catenin signaling. *Proc Natl Acad Sci U S A*115:E418-e427.
- Kijima N and Kanemura Y (2016) Molecular Classification of Medulloblastoma. *Neurol Med Chir (Tokyo)*56:687-697.
- Kim C, Cheng CY, Saldanha SA and Taylor SS (2007) PKA-I Holoenzyme Structure Reveals a Mechanism for cAMP-Dependent Activation. *Cell*130:1032-1043.
- Kim C, Vigil D, Anand G and Taylor SS (2006) Structure and dynamics of PKA signaling proteins. *Eur J Cell Biol*85:651-654.
- Kim EJ and Juhn YS (2015) Cyclic AMP signaling reduces sirtuin 6 expression in non-small cell lung cancer cells by promoting ubiquitin-proteasomal degradation via inhibition of the Raf-MEK-ERK (Raf/mitogen-activated extracellular signal-regulated kinase/extracellular signal-regulated kinase) pathway. *J Biol Chem*290:9604-9613.
- Kim JW, Abudayyeh OO, Yeerna H, Yeang C-H, Stewart M, Jenkins RW, Kitajima S, Konieczkowski DJ, Medetgul-Ernar K, Cavazos T, Mah C, Ting S, Van Allen EM, Cohen O, McDermott J, Damato E, Aguirre AJ, Liang J, Liberzon A, Alexe G, Doench J, Ghandi M, Vazquez F, Weir BA, Tsherniak A, Subramanian A, Meneses-Cime K, Park J, Clemons P, Garraway LA, Thomas D, Boehm JS, Barbie DA, Hahn WC, Mesirov JP and Tamayo P (2017) Decomposing Oncogenic Transcriptional Signatures to Generate Maps of Divergent Cellular States. *Cell Systems*5:105-118.e109.

- Kim JW, Botvinnik OB, Abudayyeh O, Birger C, Rosenbluh J, Shrestha Y, Abazeed ME, Hammerman PS, DiCara D, Konieczkowski DJ, Johannessen CM, Liberzon A, Alizad-Rahvar AR, Alexe G, Aguirre A, Ghandi M, Greulich H, Vazquez F, Weir BA, Van Allen EM, Tsherniak A, Shao DD, Zack TI, Noble M, Getz G, Beroukhir R, Garraway LA, Ardakani M, Romualdi C, Sales G, Barbie DA, Boehm JS, Hahn WC, Mesirov JP and Tamayo P (2016) Characterizing genomic alterations in cancer by complementary functional associations. *Nat Biotechnol*34:539-546.
- Kim M, Kim M, Lee S, Kuninaka S, Saya H, Lee H, Lee S and Lim D-S (2013) cAMP/PKA signalling reinforces the LATS–YAP pathway to fully suppress YAP in response to actin cytoskeletal changes. *EMBO J*32:1543-1555.
- Kim P and Zhou X (2019) FusionGDB: fusion gene annotation DataBase. *Nucleic Acids Res*47:D994-d1004.
- Kirschner LS, Carney JA, Pack SD, Taymans SE, Giatzakis C, Cho YS, Cho-Chung YS and Stratakis CA (2000a) Mutations of the gene encoding the protein kinase A type I- α regulatory subunit in patients with the Carney complex. *Nat Genet*26:89-92.
- Kirschner LS, Sandrini F, Monbo J, Lin JP, Carney JA and Stratakis CA (2000b) Genetic heterogeneity and spectrum of mutations of the PRKAR1A gene in patients with the Carney complex. *Hum Mol Genet*9:3037-3046.
- Knape MJ, Ballez M, Burghardt NC, Zimmermann B, Bertinetti D, Kornev AP and Herberg FW (2017) Divalent metal ions control activity and inhibition of protein kinases. *Metallomics*9:1576-1584.
- Knighton D, Zheng J, Ten Eyck L, Ashford V, Xuong N, Taylor S and Sowadski J (1991a) Crystal structure of the catalytic subunit of cyclic adenosine monophosphate-dependent protein kinase. *Science*253:407-414.
- Knighton DR, Zheng JH, Ten Eyck LF, Xuong NH, Taylor SS and Sowadski JM (1991b) Structure of a peptide inhibitor bound to the catalytic subunit of cyclic adenosine monophosphate-dependent protein kinase. *Science*253:414-420.
- Kolligs FT, Bommer G and Göke B (2002) Wnt/Beta-Catenin/Tcf Signaling: A Critical Pathway in Gastrointestinal Tumorigenesis. *Digestion*66:131-144.
- Komatsu H, Tanji E, Sakata N, Aoki T, Motoi F, Naitoh T, Katayose Y, Egawa S, Unno M and Furukawa T (2014) A GNAS mutation found in pancreatic intraductal papillary mucinous neoplasms induces drastic alterations of gene expression profiles with upregulation of mucin genes. *PLoS One*9:e87875.
- Konermann S, Brigham MD, Trevino AE, Joung J, Abudayyeh OO, Barcena C, Hsu PD, Habib N, Gootenberg JS, Nishimasu H, Nureki O and Zhang F (2015) Genome-scale transcriptional activation by an engineered CRISPR-Cas9 complex. *Nature*517:583-588.
- Kool M, Jones DT, Jager N, Northcott PA, Pugh TJ, Hovestadt V, Piro RM, Esparza LA, Markant SL, Remke M, Milde T, Bourdeaut F, Ryzhova M, Sturm D, Pfaff E, Stark S, Hutter S, Seker-Cin H, Johann P, Bender S, Schmidt C, Rausch T, Shih D, Reimand J, Sieber L, Wittmann A, Linke L, Witt H, Weber UD, Zapatka M, König R, Beroukhir R, Bergthold G,

- van Sluis P, Volckmann R, Koster J, Versteeg R, Schmidt S, Wolf S, Lawerenz C, Bartholomae CC, von Kalle C, Unterberg A, Herold-Mende C, Hofer S, Kulozik AE, von Deimling A, Scheurlen W, Felsberg J, Reifemberger G, Hasselblatt M, Crawford JR, Grant GA, Jabado N, Perry A, Cowdrey C, Croul S, Zadeh G, Korbel JO, Doz F, Delattre O, Bader GD, McCabe MG, Collins VP, Kieran MW, Cho YJ, Pomeroy SL, Witt O, Brors B, Taylor MD, Schuller U, Korshunov A, Eils R, Wechsler-Reya RJ, Lichter P, Pfister SM and Project IPT (2014) Genome sequencing of SHH medulloblastoma predicts genotype-related response to smoothed inhibition. *Cancer Cell*25:393-405.
- Kuettel MR, Squinto SP, Kwast-Welfeld J, Schwoch G, Schweppe JS and Jungmann RA (1985) Localization of nuclear subunits of cyclic AMP-dependent protein kinase by the immunocolloidal gold method. *J Cell Biol*101:965-975.
- Kuracha MR, Thomas P, Loggie BW and Govindarajan V (2016) Patient-derived xenograft mouse models of pseudomyxoma peritonei recapitulate the human inflammatory tumor microenvironment. *Cancer Med*5:711-719.
- Lacka K and Maciejewski A (2015) Rare thyroid non-neoplastic diseases. *Thyroid Res*8:5.
- Land H, Parada LF and Weinberg RA (1983) Tumorigenic conversion of primary embryo fibroblasts requires at least two cooperating oncogenes. *Nature*304:596-602.
- Landis CA, Masters SB, Spada A, Pace AM, Bourne HR and Vallar L (1989) GTPase inhibiting mutations activate the alpha chain of Gs and stimulate adenylyl cyclase in human pituitary tumours. *Nature*340:692-696.
- Landrum MJ, Chitipiralla S, Brown GR, Chen C, Gu B, Hart J, Hoffman D, Jang W, Kaur K, Liu C, Lyoshin V, Maddipatla Z, Maiti R, Mitchell J, O'Leary N, Riley GR, Shi W, Zhou G, Schneider V, Maglott D, Holmes JB and Kattman BL (2020) ClinVar: improvements to accessing data. *Nucleic Acids Res*48:D835-d844.
- Langeberg LK and Scott JD (2015) Signalling scaffolds and local organization of cellular behaviour. *Nat Rev Mol Cell Bio*16:232-244.
- Lania AG, Mantovani G and Spada A (2006) Mechanisms of Disease: mutations of G proteins and G-protein-coupled receptors in endocrine diseases. *Nat Clin Pract Endoc*2:681-693.
- Lanzi C, Borrello MG, Bongarzone I, Migliazza A, Fusco A, Grieco M, Santoro M, Gambetta RA, Zunino F, Della Porta G and et al. (1992) Identification of the product of two oncogenic rearranged forms of the RET proto-oncogene in papillary thyroid carcinomas. *Oncogene*7:2189-2194.
- Larkin SJ, Ferraù F, Karavitaki N, Hernández-Ramírez LC, Ansorge O, Grossman AB and Korbonits M (2014) Sequence analysis of the catalytic subunit of PKA in somatotroph adenomas. *Eur J Endocrinol*171:705-710.
- Lavogina D, Enkvist E and Uri A (2010) Bisubstrate inhibitors of protein kinases: from principle to practical applications. *ChemMedChem*5:23-34.
- Lee DW, Han SW, Lee HJ, Rhee YY, Bae JM, Cho NY, Lee KH, Kim TY, Oh DY, Im SA, Bang YJ, Jeong SY, Park KJ, Park JG, Kang GH and Kim TY (2013) Prognostic implication of

- mucinous histology in colorectal cancer patients treated with adjuvant FOLFOX chemotherapy. *Br J Cancer*108:1978-1984.
- Lee JH, Kim TS, Yang TH, Koo BK, Oh SP, Lee KP, Oh HJ, Lee SH, Kong YY, Kim JM and Lim DS (2008) A crucial role of WW45 in developing epithelial tissues in the mouse. *EMBO J*27:1231-1242.
- Lee LS, Doyle LA, Houghton J, Sah S, Bellizzi AM, Szafranska-Schwarzbach AE, Conner JR, Kadiyala V, Suleiman SL, Banks PA, Andruss BF and Conwell DL (2014) Differential expression of GNAS and KRAS mutations in pancreatic cysts. *Jop*15:581-586.
- Lee-Six H, Olafsson S, Ellis P, Osborne RJ, Sanders MA, Moore L, Georgakopoulos N, Torrente F, Noorani A, Goddard M, Robinson P, Coorens THH, O'Neill L, Alder C, Wang J, Fitzgerald RC, Zilbauer M, Coleman N, Saeb-Parsy K, Martincorena I, Campbell PJ and Stratton MR (2019) The landscape of somatic mutation in normal colorectal epithelial cells. *Nature*574:532-537.
- Leone RD, Lo YC and Powell JD (2015) A2aR antagonists: Next generation checkpoint blockade for cancer immunotherapy. *Comput Struct Biotechnol J*13:265-272.
- Lignitto L, Carlucci A, Sepe M, Stefan E, Cuomo O, Nisticò R, Scorziello A, Savoia C, Garbi C, Annunziato L and Feliciello A (2011) Control of PKA stability and signalling by the RING ligase praja2. *Nat Cell Biol*13:412-422.
- Linglart A, Menguy C, Couvineau A, Auzan C, Gunes Y, Cancel M, Motte E, Pinto G, Chanson P, Bougnères P, Clauser E and Silve C (2011) Recurrent PRKAR1A Mutation in Acrodysostosis with Hormone Resistance. *N Engl J Med*364:2218-2226.
- Liu C, Ke P, Zhang J, Zhang X and Chen X (2020) Protein Kinase Inhibitor Peptide as a Tool to Specifically Inhibit Protein Kinase A. *Front Physiol*11.
- Lochner A and Moolman JA (2006) The many faces of H89: a review. *Cardiovasc Drug Rev*24:261-274.
- Lodish MB, Yuan B, Levy I, Braunstein GD, Lyssikatos C, Salpea P, Szarek E, Karageorgiadis AS, Belyavskaya E, Raygada M, Faucz FR, Izzat L, Brain C, Gardner J, Quezado M, Carney JA, Lupski JR and Stratakis CA (2015) Germline PRKACA amplification causes variable phenotypes that may depend on the extent of the genomic defect: molecular mechanisms and clinical presentations. *Eur J Endocrinol*172:803-811.
- Long DN, McGuire S, Levine MA, Weinstein LS and Germain-Lee EL (2007) Body mass index differences in pseudohypoparathyroidism type 1a versus pseudopseudohypoparathyroidism may implicate paternal imprinting of Galpha(s) in the development of human obesity. *J Clin Endocrinol Metab*92:1073-1079.
- Lowry WE, Flores A and White AC (2016) Exploiting Mouse Models to Study Ras-Induced Cutaneous Squamous Cell Carcinoma. *J Invest Dermatol*136:1543-1548.
- Lu T-W, Aoto PC, Weng J-H, Nielsen C, Cash JN, Hall J, Zhang P, Simon SM, Cianfrocco MA and Taylor SS (2021) Structural analyses of the PKA RII β holoenzyme containing the

- oncogenic DnaJB1-PKAc fusion protein reveal protomer asymmetry and fusion-induced allosteric perturbations in fibrolamellar hepatocellular carcinoma. *PLoS Biol*18:e3001018.
- Lubner JM, Dodge-Kafka KL, Carlson CR, Church GM, Chou MF and Schwartz D (2017) Cushing's syndrome mutant PKA(L)(205R) exhibits altered substrate specificity. *FEBS Lett*591:459-467.
- Lukong KE, Chang KW, Khandjian EW and Richard S (2008) RNA-binding proteins in human genetic disease. *Trends Genet*24:416-425.
- Luo Y, Blex C, Baessler O, Glinski M, Dreger M, Sefkow M and Köster H (2009) The cAMP capture compound mass spectrometry as a novel tool for targeting cAMP-binding proteins: from protein kinase A to potassium/sodium hyperpolarization-activated cyclic nucleotide-gated channels. *Mol Cell Proteomics*8:2843-2856.
- Luzi NM, Lyons CE, Peterson DL and Ellis KC (2018) Kinetics and inhibition studies of the L205R mutant of cAMP-dependent protein kinase involved in Cushing's syndrome. *FEBS Open Bio*8:606-613.
- Ma S, Liu W, Zhang A, Pan L, Tang W, Jiang B, Wang F, Chen S and Fu B (2019) Identification of a PRKAR1A mutation (c.491_492delTG) in familial cardiac myxoma: A case report. *Medicine (Baltimore)*98:e14866.
- Ma Y and Taylor SS (2008) A molecular switch for targeting between endoplasmic reticulum (ER) and mitochondria: conversion of a mitochondria-targeting element into an ER-targeting signal in DAKAP1. *J Biol Chem*283:11743-11751.
- Maass PG, Aydin A, Luft FC, Schächterle C, Weise A, Stricker S, Lindschau C, Vaegler M, Qadri F, Toka HR, Schulz H, Krawitz PM, Parkhomchuk D, Hecht J, Hollfinger I, Wefeld-Neuenfeld Y, Bartels-Klein E, Mühl A, Kann M, Schuster H, Chitayat D, Bialer MG, Wienker TF, Ott J, Rittscher K, Liehr T, Jordan J, Plessis G, Tank J, Mai K, Naraghi R, Hodge R, Hopp M, Hattenbach LO, Busjahn A, Rauch A, Vandeput F, Gong M, Rüschenhoff F, Hübner N, Haller H, Mundlos S, Bilginturan N, Movsesian MA, Klusmann E, Toka O and Bähring S (2015) PDE3A mutations cause autosomal dominant hypertension with brachydactyly. *Nat Genet*47:647-653.
- Mahauad-Fernandez WD and Felsher DW (2020) The Myc and Ras Partnership in Cancer: Indistinguishable Alliance or Contextual Relationship? *Cancer Res*80:3799-3802.
- Mak IW, Evaniew N and Ghert M (2014) Lost in translation: animal models and clinical trials in cancer treatment. *Am J Transl Res*6:114-118.
- Maleszewski JJ, Larsen BT, Kip NS, Castonguay MC, Edwards WD, Carney JA and Kipp BR (2014) PRKAR1A in the development of cardiac myxoma: a study of 110 cases including isolated and syndromic tumors. *Am J Surg Pathol*38:1079-1087.
- Mancarella C and Scotlandi K (2020) IGF2BP3 From Physiology to Cancer: Novel Discoveries, Unsolved Issues, and Future Perspectives. *Front Cell Dev Biol*7:363-363.
- Manna PR, Dyson MT and Stocco DM (2009) Regulation of the steroidogenic acute regulatory protein gene expression: present and future perspectives. *Mol Hum Reprod*15:321-333.

- Manschwetetus JT, Bendzunas GN, Limaye AJ, Knape MJ, Herberg FW and Kennedy EJ (2019) A Stapled Peptide Mimic of the Pseudosubstrate Inhibitor PKI Inhibits Protein Kinase A. *Molecules*24.
- Mantovani G and Elli FM (2018) Multiple hormone resistance and alterations of G-protein-coupled receptors signaling. *Best Pract Res Clin Endocrinol Metab*32:141-154.
- Mantovani G, Bondioni S, Locatelli M, Pedroni C, Lania AG, Ferrante E, Filopanti M, Beck-Peccoz P and Spada A (2004) Biallelic Expression of the Gs α Gene in Human Bone and Adipose Tissue. *J Clin Endocrinol Metab*89:6316-6319.
- Marbach F, Stoyanov G, Erger F, Stratakis CA, Settas N, London E, Rosenfeld JA, Torti E, Haldeman-Englert C, Sklirou E, Kessler E, Ceulemans S, Nelson SF, Martinez-Agosto JA, Palmer CGS, Signer RH, Andrews MV, Grange DK, Willaert R, Person R, Telegrafi A, Sievers A, Laugsch M, Theiß S, Cheng Y, Lichtarge O, Katsonis P, Stocco A and Schaaf CP (2021) Variants in PRKAR1B cause a neurodevelopmental disorder with autism spectrum disorder, apraxia, and insensitivity to pain. *Genet Med*.
- Markowitz SD and Bertagnolli MM (2009) Molecular origins of cancer: Molecular basis of colorectal cancer. *N Engl J Med*361:2449-2460.
- Martin AL, Steurer MA and Aronstam RS (2015) Constitutive Activity among Orphan Class-A G Protein Coupled Receptors. *PLoS One*10:e0138463.
- Martinez A and Gil C (2014) cAMP-specific phosphodiesterase inhibitors: promising drugs for inflammatory and neurological diseases. *Expert Opin Ther Pat*24:1311-1321.
- Marti-Solano M, Crilly SE, Malinverni D, Munk C, Harris M, Pearce A, Quon T, Mackenzie AE, Wang X, Peng J, Tobin AB, Ladds G, Milligan G, Gloriam DE, Puthenveedu MA and Babu MM (2020) Combinatorial expression of GPCR isoforms affects signalling and drug responses. *Nature*587:650-656.
- Mathieu M, Drelon C, Rodriguez S, Tabbal H, Septier A, Damon-Soubeyrand C, Dumontet T, Berthon A, Sahut-Barnola I, Djari C, Batische-Lignier M, Pointud J-C, Richard D, Kerdivel G, Calmèjane M-A, Boeva V, Tauveron I, Lefrançois-Martinez A-M, Martinez A and Val P (2018) Steroidogenic differentiation and PKA signaling are programmed by histone methyltransferase EZH2 in the adrenal cortex. *Proc Natl Acad Sci U S A*115:E12265-E12274.
- Mavanur AA, Parimi V, O'Malley M, Nikiforova M, Bartlett DL and Davison JM (2010) Establishment and characterization of a murine xenograft model of appendiceal mucinous adenocarcinoma. *Int J Exp Pathol*91:357-367.
- Mavillard F, Hidalgo J, Megias D, Levitsky KL and Velasco A (2010) PKA-Mediated Golgi Remodeling During cAMP Signal Transmission. *Traffic*11:90-109.
- McFarland JM, Ho ZV, Kugener G, Dempster JM, Montgomery PG, Bryan JG, Krill-Burger JM, Green TM, Vazquez F, Boehm JS, Golub TR, Hahn WC, Root DE and Tsherniak A (2018) Improved estimation of cancer dependencies from large-scale RNAi screens using model-based normalization and data integration. *Nat Commun*9:4610.

- McKeage K (2013) Pasireotide: a review of its use in Cushing's disease. *Drugs*73:563-574.
- Meggio F, Donella Deana A, Ruzzene M, Brunati AM, Cesaro L, Guerra B, Meyer T, Mett H, Fabbro D, Furet P and et al. (1995) Different susceptibility of protein kinases to staurosporine inhibition. Kinetic studies and molecular bases for the resistance of protein kinase CK2. *Eur J Biochem*234:317-322.
- Meoli E, Bossis I, Cazabat L, Mavrakis M, Horvath A, Stergiopoulos S, Shiferaw ML, Fumey G, Perlemoine K, Muchow M, Robinson-White A, Weinberg F, Nesterova M, Patronas Y, Groussin L, Bertherat J and Stratakis CA (2008) Protein Kinase A Effects of an Expressed *PRKAR1A* Mutation Associated with Aggressive Tumors. *Cancer Res*68:3133-3141.
- Meyer KD, Saletore Y, Zumbo P, Elemento O, Mason CE and Jaffrey SR (2012) Comprehensive analysis of mRNA methylation reveals enrichment in 3' UTRs and near stop codons. *Cell*149:1635-1646.
- Meyers RM, Bryan JG, McFarland JM, Weir BA, Sizemore AE, Xu H, Dharia NV, Montgomery PG, Cowley GS, Pantel S, Goodale A, Lee Y, Ali LD, Jiang G, Lubonja R, Harrington WF, Strickland M, Wu T, Hawes DC, Zhivich VA, Wyatt MR, Kalani Z, Chang JJ, Okamoto M, Stegmaier K, Golub TR, Boehm JS, Vazquez F, Root DE, Hahn WC and Tsherniak A (2017) Computational correction of copy number effect improves specificity of CRISPR-Cas9 essentiality screens in cancer cells. *Nat Genet*49:1779-1784.
- Michalides R, Griekspoor A, Balkenende A, Verwoerd D, Janssen L, Jalink K, Floore A, Velds A, van 't Veer L and Neefjes J (2004) Tamoxifen resistance by a conformational arrest of the estrogen receptor α after PKA activation in breast cancer. *Cancer Cell*5:597-605.
- Micol J-B, Pastore A, Inoue D, Duployez N, Kim E, Lee SC-W, Durham BH, Chung YR, Cho H, Zhang XJ, Yoshimi A, Krivtsov A, Koche R, Solary E, Sinha A, Preudhomme C and Abdel-Wahab O (2017) ASXL2 is essential for haematopoiesis and acts as a haploinsufficient tumour suppressor in leukemia. *Nat Commun*8:15429.
- Mika D, Leroy J, Vandecasteele G and Fischmeister R (2012) PDEs create local domains of cAMP signaling. *J Mol Cell Cardiol*52:323-329.
- Miller LJ, Sexton PM, Dong M and Harikumar KG (2014) The class B G-protein-coupled GLP-1 receptor: an important target for the treatment of type-2 diabetes mellitus. *Int J Obes Suppl*4:S9-S13.
- Milunsky J, Huang XL, Baldwin CT, Farah MG and Milunsky A (1998) Evidence for genetic heterogeneity of the Carney complex (familial atrial myxoma syndromes). *Cancer Genet Cytogenet*106:173-176.
- Moen LV, Sener Z, Volchenkov R, Svarstad AC, Eriksen AM, Holen HL and Skålhegg BS (2017) Ablation of the C β 2 subunit of PKA in immune cells leads to increased susceptibility to systemic inflammation in mice. *Eur J Immunol*47:1880-1889.
- Molin MD, Matthaei H, Wu J, Blackford A, Debeljak M, Rezaee N, Wolfgang CL, Butturini G, Salvia R, Bassi C, Goggins MG, Kinzler KW, Vogelstein B, Eshleman JR, Hruban RH and Maitra A (2013) Clinicopathological correlates of activating GNAS mutations in intraductal papillary mucinous neoplasm (IPMN) of the pancreas. *Ann Surg Oncol*20:3802-3808.

- Montminy MR, Sevarino KA, Wagner JA, Mandel G and Goodman RH (1986) Identification of a cyclic-AMP-responsive element within the rat somatostatin gene. *Proc Natl Acad Sci U S A*83:6682-6686.
- Moody SE, Schinzel AC, Singh S, Izzo F, Strickland MR, Luo L, Thomas SR, Boehm JS, Kim SY, Wang ZC and Hahn WC (2015) PRKACA mediates resistance to HER2-targeted therapy in breast cancer cells and restores anti-apoptotic signaling. *Oncogene*34:2061-2071.
- Moore MJ, Adams JA and Taylor SS (2003) Structural basis for peptide binding in protein kinase A. Role of glutamic acid 203 and tyrosine 204 in the peptide-positioning loop. *J Biol Chem*278:10613-10618.
- Morris JH, Kuchinsky A, Ferrin TE and Pico AR (2014) enhancedGraphics: a Cytoscape app for enhanced node graphics. *F1000Res*3:147.
- Mouallem M, Shaharabany M, Weintrob N, Shalitin S, Nagelberg N, Shapira H, Zadik Z and Farfel Z (2008) Cognitive impairment is prevalent in pseudohypoparathyroidism type Ia, but not in pseudopseudohypoparathyroidism: possible cerebral imprinting of Gsalpha. *Clin Endocrinol (Oxf)*68:233-239.
- Muda K, Bertinetti D, Gesellchen F, Hermann JS, von Zweydford F, Geerlof A, Jacob A, Ueffing M, Gloeckner CJ and Herberg FW (2014) Parkinson-related LRRK2 mutation R1441C/G/H impairs PKA phosphorylation of LRRK2 and disrupts its interaction with 14-3-3. *Proc Natl Acad Sci U S A*111:E34-43.
- Mukhopadhyay S and Rohatgi R (2014) G-protein-coupled receptors, Hedgehog signaling and primary cilia. *Semin Cell Dev Biol*33:63-72.
- Mullard A (2020) Targeted degraders clear first safety hurdles. *Nat Rev Drug Discov*19:435.
- Mullard A (2021) Targeted protein degraders crowd into the clinic. *Nat Rev Drug Discov*20:247-250.
- Muñiz M, Alonso M, Hidalgo J and Velasco A (1996) A regulatory role for cAMP-dependent protein kinase in protein traffic along the exocytic route. *J Biol Chem*271:30935-30941.
- Murray AJ (2008) Pharmacological PKA Inhibition: All May Not Be What It Seems. *Sci Signal*1:re4-re4.
- Mykytyn K and Askwith C (2017) G-Protein-Coupled Receptor Signaling in Cilia. *Cold Spring Harb Perspect Biol*9:a028183.
- Nagai Y, Nishimura A, Tago K, Mizuno N and Itoh H (2010) Ric-8B stabilizes the alpha subunit of stimulatory G protein by inhibiting its ubiquitination. *J Biol Chem*285:11114-11120.
- Nagy G, Reim K, Matti U, Brose N, Binz T, Rettig J, Neher E and Sørensen JB (2004) Regulation of releasable vesicle pool sizes by protein kinase A-dependent phosphorylation of SNAP-25. *Neuron*41:417-429.

- Nakamura H, Arai Y, Totoki Y, Shirota T, Elzawahry A, Kato M, Hama N, Hosoda F, Urushidate T, Ohashi S, Hiraoka N, Ojima H, Shimada K, Okusaka T, Kosuge T, Miyagawa S and Shibata T (2015) Genomic spectra of biliary tract cancer. *Nat Genet*47:1003-1010.
- Nassar D, Latil M, Boeckx B, Lambrechts D and Blanpain C (2015) Genomic landscape of carcinogen-induced and genetically induced mouse skin squamous cell carcinoma. *Nature Medicine*21:946-954.
- Natochin M and Artemyev NO (1998a) A single mutation Asp229 --> Ser confers upon Gs alpha the ability to interact with regulators of G protein signaling. *Biochemistry*37:13776-13780.
- Natochin M and Artemyev NO (1998b) Substitution of transducin ser202 by asp abolishes G-protein/RGS interaction. *J Biol Chem*273:4300-4303.
- Naviglio S, Pagano M, Romano M, Sorrentino A, Fusco A, Illiano F, Chiosi E, Spina A and Illiano G (2004) Adenylate cyclase regulation via proteasome-mediated modulation of Galphas levels. *Cell Signal*16:1229-1237.
- NCI (2020) Cancer Statistics, National Cancer Institute.
- Nelson KN, Peiris MN, Meyer AN, Siari A and Donoghue DJ (2017) Receptor Tyrosine Kinases: Translocation Partners in Hematopoietic Disorders. *Trends Mol Med*23:59-79.
- Nesterova M, Noguchi K, Park YG, Lee YN and Cho-Chung YS (2000) Compensatory stabilization of RIIbeta protein, cell cycle deregulation, and growth arrest in colon and prostate carcinoma cells by antisense-directed down-regulation of protein kinase A RIalpha protein. *Clin Cancer Res*6:3434-3441.
- Neves-Zaph SR (2017) Phosphodiesterase Diversity and Signal Processing Within cAMP Signaling Networks. *Adv Neurobiol*17:3-14.
- Newick K, O'Brien S, Sun J, Kapoor V, Maceyko S, Lo A, Puré E, Moon E and Albelda SM (2016) Augmentation of CAR T-cell Trafficking and Antitumor Efficacy by Blocking Protein Kinase A Localization. *Cancer Immunol Res*4:541-551.
- Niewiadomski P, Zhujiang A, Youssef M and Waschek JA (2013) Interaction of PACAP with Sonic hedgehog reveals complex regulation of the hedgehog pathway by PKA. *Cell Signal*25:2222-2230.
- Nikolaev VO, Moshkov A, Lyon AR, Miragoli M, Novak P, Paur H, Lohse MJ, Korchev YE, Harding SE and Gorelik J (2010) β_2 -Adrenergic Receptor Redistribution in Heart Failure Changes cAMP Compartmentation. *Science*327:1653-1657.
- Nishihara E, Amino N, Maekawa K, Yoshida H, Ito M, Kubota S, Fukata S and Miyauchi A (2009) Prevalence of TSH receptor and Gs α mutations in 45 autonomously functioning thyroid nodules in Japan. *Endocr J*56:791-798.
- Nishikawa G, Sekine S, Ogawa R, Matsubara A, Mori T, Taniguchi H, Kushima R, Hiraoka N, Tsuta K, Tsuda H and Kanai Y (2013) Frequent GNAS mutations in low-grade appendiceal mucinous neoplasms. *Br J Cancer*108:951-958.

- Nishiyama K, Takaji K, Uchijima Y, Kurihara Y, Asano T, Yoshimura M, Ogawa H and Kurihara H (2007) Protein kinase A-regulated nucleocytoplasmic shuttling of Id1 during angiogenesis. *J Biol Chem*282:17200-17209.
- Niswender C, Willis B, Wallen A, Sweet I, Jetton T, Thompson B, Wu C, Lange A and McKnight G (2005) Cre recombinase-dependent expression of a constitutively active mutant allele of the catalytic subunit of protein kinase A. *Genesis*43:109-119.
- Nonga OE, Enkvist E, Herberg FW and Uri A (2020) Inhibitors and fluorescent probes for protein kinase PKAc β and its S54L mutant, identified in a patient with cortisol producing adenoma. *Biosci Biotechnol Biochem*84:1839-1845.
- Novitskiy SV, Ryzhov S, Zaynagetdinov R, Goldstein AE, Huang Y, Tikhomirov OY, Blackburn MR, Biaggioni I, Carbone DP, Feoktistov I and Dikov MM (2008) Adenosine receptors in regulation of dendritic cell differentiation and function. *Blood*112:1822-1831.
- Novotny J and Svoboda P (1998) The long (Gs(alpha)-L) and short (Gs(alpha)-S) variants of the stimulatory guanine nucleotide-binding protein. Do they behave in an identical way? *J Mol Endocrinol*20:163-173.
- Nummela P, Saarinen L, Thiel A, Järvinen P, Lehtonen R, Lepistö A, Järvinen H, Aaltonen LA, Hautaniemi S and Ristimäki A (2015) Genomic profile of pseudomyxoma peritonei analyzed using next-generation sequencing and immunohistochemistry. *Int J Cancer*136:E282-E289.
- Oberholzer PA, Kee D, Dziunycz P, Sucker A, Kamsukom N, Jones R, Roden C, Chalk CJ, Ardlie K, Palescandolo E, Piris A, MacConaill LE, Robert C, Hofbauer GF, McArthur GA, Schadendorf D and Garraway LA (2012) RAS mutations are associated with the development of cutaneous squamous cell tumors in patients treated with RAF inhibitors. *J Clin Oncol*30:316-321.
- O'Connell JT, Hacker CM and Barsky SH (2002) MUC2 Is a Molecular Marker for Pseudomyxoma Peritonei. *Mod Pathol*15:958-972.
- Ogden SK, Fei DL, Schilling NS, Ahmed YF, Hwa J and Robbins DJ (2008) G protein Galphai functions immediately downstream of Smoothed in Hedgehog signalling. *Nature*456:967-970.
- O'Hayre M, Vazquez-Prado J, Kufareva I, Stawiski EW, Handel TM, Seshagiri S and Gutkind JS (2013) The emerging mutational landscape of G proteins and G-protein-coupled receptors in cancer. *Nat Rev Cancer*13:412-424.
- Ohoka N, Okuhira K, Ito M, Nagai K, Shibata N, Hattori T, Ujikawa O, Shimokawa K, Sano O, Koyama R, Fujita H, Teratani M, Matsumoto H, Imaeda Y, Nara H, Cho N and Naito M (2017) In Vivo Knockdown of Pathogenic Proteins via Specific and Nongenetic Inhibitor of Apoptosis Protein (IAP)-dependent Protein Erasers (SNIPERs) *. *J Biol Chem*292:4556-4570.
- Oldham WM and Hamm HE (2008) Heterotrimeric G protein activation by G-protein-coupled receptors. *Nature Reviews Molecular Cell Biology*9:60-71.

- Olivieri C, Walker C, Karamafrooz A, Wang Y, Manu VS, Porcelli F, Blumenthal DK, Thomas DD, Bernlohr DA, Simon SM, Taylor SS and Veglia G (2021) Defective internal allosteric network imparts dysfunctional ATP/substrate-binding cooperativity in oncogenic chimera of protein kinase A. *Communications Biology*4:321.
- Olson B, Li Y, Lin Y, Liu ET and Patnaik A (2018) Mouse Models for Cancer Immunotherapy Research. *Cancer Discov*8:1358-1365.
- Omar F, Findlay JE, Carfray G, Allcock RW, Jiang Z, Moore C, Muir AL, Lannoy M, Fertig BA, Mai D, Day JP, Bolger G, Baillie GS, Schwiebert E, Klussmann E, Pyne NJ, Ong ACM, Bowers K, Adam JM, Adams DR, Houslay MD and Henderson DJP (2019) Small-molecule allosteric activators of PDE4 long form cyclic AMP phosphodiesterases. *Proc Natl Acad Sci U S A*116:13320-13329.
- Omar MH and Scott JD (2020) AKAP Signaling Islands: Venues for Precision Pharmacology. *Trends Pharmacol Sci*41:933-946.
- Omori K and Kotera J (2007) Overview of PDEs and Their Regulation. *Circ Res*100:309-327.
- Orchard S, Kerrien S, Abbani S, Aranda B, Bhate J, Bidwell S, Bridge A, Briganti L, Brinkman FSL, Cesareni G, Chatr-aryamontri A, Chautard E, Chen C, Dumousseau M, Goll J, Hancock REW, Hannick LI, Jurisica I, Khadake J, Lynn DJ, Mahadevan U, Perfetto L, Raghunath A, Ricard-Blum S, Roechert B, Salwinski L, Stümpflen V, Tyers M, Uetz P, Xenarios I and Hermjakob H (2012) Protein interaction data curation: the International Molecular Exchange (IMEx) consortium. *Nat Methods*9:345-350.
- Ostrem JM, Peters U, Sos ML, Wells JA and Shokat KM (2013) K-Ras(G12C) inhibitors allosterically control GTP affinity and effector interactions. *Nature*503:548-551.
- Oughtred R, Rust J, Chang C, Breitkreutz BJ, Stark C, Willems A, Boucher L, Leung G, Kolas N, Zhang F, Dolma S, Coulombe-Huntington J, Chatr-Aryamontri A, Dolinski K and Tyers M (2021) The BioGRID database: A comprehensive biomedical resource of curated protein, genetic, and chemical interactions. *Protein Sci*30:187-200.
- Ould Amer Y and Hebert-Chatelain E (2018) Mitochondrial cAMP-PKA signaling: What do we really know? *Biochim Biophys Acta*1859:868-877.
- Palencia-Campos A, Aoto PC, Machal EMF, Rivera-Barahona A, Soto-Bielicka P, Bertinetti D, Baker B, Vu L, Picci-Sparascio F, Torrente I, Boudin E, Peeters S, Van Hul W, Huber C, Bonneau D, Hildebrand MS, Coleman M, Bahlo M, Bennett MF, Schneider AL, Scheffer IE, Kibæk M, Kristiansen BS, Issa MY, Mehrez MI, Ismail S, Tenorio J, Li G, Skålhegg BS, Otaify GA, Temtamy S, Aglan M, Jønch AE, De Luca A, Mortier G, Cormier-Daire V, Ziegler A, Wallis M, Lapunzina P, Herberg FW, Taylor SS and Ruiz-Perez VL (2020) Germline and Mosaic Variants in PRKACA and PRKACB Cause a Multiple Congenital Malformation Syndrome. *Am J Hum Genet*107:977-988.
- Palorini R, De Rasmio D, Gaviraghi M, Danna LS, Signorile A, Cirulli C, Chiaradonna F, Alberghina L and Papa S (2013) Oncogenic K-ras expression is associated with derangement of the cAMP/PKA pathway and forskolin-reversible alterations of mitochondrial dynamics and respiration. *Oncogene*32:352-362.

- Palorini R, Votta G, Pirola Y, De Vitto H, De Palma S, Airoidi C, Vasso M, Ricciardiello F, Lombardi PP, Cirulli C, Rizzi R, Nicotra F, Hiller K, Gelfi C, Alberghina L and Chiaradonna F (2016) Protein Kinase A Activation Promotes Cancer Cell Resistance to Glucose Starvation and Anoikis. *PLoS Genet*12:e1005931-e1005931.
- Palos-Paz F, Perez-Guerra O, Cameselle-Teijeiro J, Rueda-Chimeno C, Barreiro-Morandeira F, Lado-Abeal J, Araujo V, Argueso R, Barca O, Botana M, Cabezas-Agricola J, Catalina P, Dominguez G, Fernandez T, Mato A, Nuno A, Penin M and Victoria B (2008) Prevalence of mutations in TSHR, GNAS, PRKAR1A and RAS genes in a large series of toxic thyroid adenomas from Galicia, an iodine-deficient area in NW Spain. *Eur J Endocrinol*159:623-631.
- Paradis JS, Acosta M, Saddawi-Konefka R, Kishore A, Lubrano S, Gomes FG, Arang N, Tiago M, Coma S, Wu X, Ford K, Day C-P, Merlino G, Mali P, Pachter JA, Sato T, Aplin AE and Gutkind JS (2021) Synthetic Lethal Screens Reveal Co-Targeting FAK and MEK as a Multimodal Precision Therapy for GNAQ-Driven Uveal Melanoma. *Clin Cancer Res:clincanres.3363.2020*.
- Parker D, Ferreri K, Nakajima T, LaMorte VJ, Evans R, Koerber SC, Hoeger C and Montminy MR (1996) Phosphorylation of CREB at Ser-133 induces complex formation with CREB-binding protein via a direct mechanism. *Mol Cell Biol*16:694-703.
- Patra KC, Kato Y, Mizukami Y, Widholz S, Boukhali M, Revenco I, Grossman EA, Ji F, Sadreyev RI, Liss AS, Screatton RA, Sakamoto K, Ryan DP, Mino-Kenudson M, Castillo CF, Nomura DK, Haas W and Bardeesy N (2018) Mutant GNAS drives pancreatic tumorigenesis by inducing PKA-mediated SIK suppression and reprogramming lipid metabolism. *Nat Cell Biol*20:811-822.
- Patronas Y, Horvath A, Greene E, Tsang K, Bimpaki E, Haran M, Nesterova M and Stratakis CA (2012) In Vitro Studies of Novel PRKAR1A Mutants that Extend the Predicted R1 α Protein Sequence into the 3'-Untranslated Open Reading Frame: Proteasomal Degradation Leads to R1 α Haploinsufficiency and Carney Complex. *J Clin Endocrinol Metab*97:E496-E502.
- Pattabiraman DR, Bieri B, Kober KI, Thiru P, Krall JA, Zill C, Reinhardt F, Tam WL and Weinberg RA (2016) Activation of PKA leads to mesenchymal-to-epithelial transition and loss of tumor-initiating ability. *Science*351:aad3680.
- Pelaseyed T and Hansson GC (2020) Membrane mucins of the intestine at a glance. *J Cell Sci*133.
- Pelly VS, Moeini A, Roelofsen LM, Bonavita E, Bell CR, Hutton C, Blanco-Gomez A, Banyard A, Bromley CP, Flanagan E, Chiang S-C, Jorgensen C, Schumacher TN, Thommen DS and Zelenay S (2021) Anti-inflammatory drugs remodel the tumor immune environment to enhance immune checkpoint blockade efficacy. *Cancer Discov:candisc.1815.2020*.
- Picco G, Chen ED, Alonso LG, Behan FM, Gonçalves E, Bignell G, Matchan A, Fu B, Banerjee R, Anderson E, Butler A, Benes CH, McDermott U, Dow D, Iorio F, Stronach E, Yang F, Yusa K, Saez-Rodriguez J and Garnett MJ (2019) Functional linkage of gene fusions to cancer cell fitness assessed by pharmacological and CRISPR-Cas9 screening. *Nat Commun*10:2198.

- Pietrantonio F, Berenato R, Maggi C, Caporale M, Milione M, Perrone F, Tamborini E, Baratti D, Kusamura S, Mariani L, Niger M, Mennitto A, Gloghini A, Bossi I, Settanni G, Busico A, Bagnoli PF, Di Bartolomeo M, Deraco M and de Braud F (2016) GNAS mutations as prognostic biomarker in patients with relapsed peritoneal pseudomyxoma receiving metronomic capecitabine and bevacizumab: a clinical and translational study. *J Transl Med*14:125-125.
- Pothuraju R, Krishn SR, Gautam SK, Pai P, Ganguly K, Chaudhary S, Rachagani S, Kaur S and Batra SK (2020) Mechanistic and Functional Shades of Mucins and Associated Glycans in Colon Cancer. *Cancers* 12.
- Prior IA, Hood FE and Hartley JL (2020) The Frequency of Ras Mutations in Cancer. *Cancer Res*80:2969-2974.
- Raimondi F, Inoue A, Kadji FMN, Shuai N, Gonzalez JC, Singh G, de la Vega AA, Sotillo R, Fischer B, Aoki J, Gutkind JS and Russell RB (2019) Rare, functional, somatic variants in gene families linked to cancer genes: GPCR signaling as a paradigm. *Oncogene*38:6491-6506.
- Rao R, Salloum R, Xin M and Lu QR (2016) The G protein Gas acts as a tumor suppressor in sonic hedgehog signaling-driven tumorigenesis. *Cell Cycle*15:1325-1330.
- Raudvere U, Kolberg L, Kuzmin I, Arak T, Adler P, Peterson H and Vilo J (2019) g:Profiler: a web server for functional enrichment analysis and conversions of gene lists (2019 update). *Nucleic Acids Res*47:W191-w198.
- Regard JB, Malhotra D, Gvozdenovic-Jeremic J, Josey M, Chen M, Weinstein LS, Lu J, Shore EM, Kaplan FS and Yang Y (2013) Activation of Hedgehog signaling by loss of GNAS causes heterotopic ossification. *Nat Med*19:1505-1512.
- Reynen K (1995) Cardiac myxomas. *N Engl J Med*333:1610-1617.
- Rhayem Y, Le Stunff C, Abdel Khalek W, Auzan C, Bertherat J, Linglart A, Couvineau A, Silve C and Clauser E (2015) Functional Characterization of PRKAR1A Mutations Reveals a Unique Molecular Mechanism Causing Acrodysostosis but Multiple Mechanisms Causing Carney Complex. *J Biol Chem*290:27816-27828.
- Ricouart A, Gesquiere JC, Tartar A and Sergheraert C (1991) Design of potent protein kinases inhibitors using the bisubstrate approach. *J Med Chem*34:73-78.
- Riggle KM, Riehle KJ, Kenerson HL, Turnham R, Homma MK, Kazami M, Samelson B, Bauer R, McKnight GS, Scott JD and Yeung RS (2016) Enhanced cAMP-stimulated protein kinase A activity in human fibrolamellar hepatocellular carcinoma. *Pediatr Res*80:110-118.
- Riminucci M, Fisher LW, Shenker A, Spiegel AM, Bianco P and Gehron Robey P (1997) Fibrous dysplasia of bone in the McCune-Albright syndrome: abnormalities in bone formation. *Am J Pathol*151:1587-1600.
- Riminucci M, Robey PG, Saggio I and Bianco P (2010) Skeletal progenitors and the GNAS gene: fibrous dysplasia of bone read through stem cells. *J Mol Endocrinol*45:355-364.

- Riminucci M, Saggio I, Robey PG and Bianco P (2006) Fibrous dysplasia as a stem cell disease. *J Bone Miner Res*21 Suppl 2:P125-131.
- Rinaldi L, Delle Donne R, Catalanotti B, Torres-Quesada O, Enzler F, Moraca F, Nisticò R, Chiuso F, Piccinin S, Bachmann V, Lindner HH, Garbi C, Scorziello A, Russo NA, Synofzik M, Stelzl U, Annunziato L, Stefan E and Feliciello A (2019) Feedback inhibition of cAMP effector signaling by a chaperone-assisted ubiquitin system. *Nat Commun*10:2572.
- Rinaldi L, Sepe M, Donne RD and Feliciello A (2015) A dynamic interface between ubiquitylation and cAMP signaling. *Front Pharmacol*6:177-177.
- Rios RM, Celati C, Lohmann SM, Bornens M and Keryer G (1992) Identification of a high affinity binding protein for the regulatory subunit RII beta of cAMP-dependent protein kinase in Golgi enriched membranes of human lymphoblasts. *EMBO J*11:1723-1731.
- Ristimäki A, Sivula A, Lundin J, Lundin M, Salminen T, Haglund C, Joensuu H and Isola J (2002) Prognostic Significance of Elevated Cyclooxygenase-2 Expression in Breast Cancer. *Cancer Res*62:632-635.
- Robinson-Steiner AM and Corbin JD (1983) Probable involvement of both intrachain cAMP binding sites in activation of protein kinase. *J Biol Chem*258:1032-1040.
- Röck R, Bachmann V, Bhang H-eC, Malleshaiah M, Raffener P, Mayrhofer JE, Tschaikner PM, Bister K, Aanstad P, Pomper MG, Michnick SW and Stefan E (2015a) In-vivo detection of binary PKA network interactions upon activation of endogenous GPCRs. *Sci Rep*5:11133.
- Röck R, Mayrhofer J, Bachmann V and Stefan E (2015) Impact of kinase activating and inactivating patient mutations on binary PKA interactions. *Front Pharmacol*6.
- Rogne M and Taskén K (2014) Compartmentalization of cAMP Signaling in Adipogenesis, Lipogenesis, and Lipolysis. *Horm Metab Res*46:833-840.
- Rosenberg D, Groussin L, Jullian E, Perlemoine K, Bertagna X and Bertherat J (2002) Role of the PKA-Regulated Transcription Factor CREB in Development and Tumorigenesis of Endocrine Tissues. *Ann N Y Acad Sci*968:65-74.
- Rothermel JD and Parker Botelho LH (1988) A mechanistic and kinetic analysis of the interactions of the diastereoisomers of adenosine 3',5'-(cyclic)phosphorothioate with purified cyclic AMP-dependent protein kinase. *Biochem J*251:757-762.
- Rothwell PM, Wilson M, Price JF, Belch JFF, Meade TW and Mehta Z (2012) Effect of daily aspirin on risk of cancer metastasis: a study of incident cancers during randomised controlled trials. *The Lancet*379:1591-1601.
- Ruppelt A, Mosenden R, Grönholm M, Aandahl EM, Tobin D, Carlson CR, Abrahamsen H, Herberg FW, Carpén O and Taskén K (2007) Inhibition of T Cell Activation by Cyclic Adenosine 5'-Monophosphate Requires Lipid Raft Targeting of Protein Kinase A Type I by the A-Kinase Anchoring Protein Ezrin. *The Journal of Immunology*179:5159-5168.

- Ryu H-S, Chang K-H, Yang H-W, Kim M-S, Kwon H-C and Oh K-S (2000) High Cyclooxygenase-2 Expression in Stage IB Cervical Cancer with Lymph Node Metastasis or Parametrial Invasion. *Gynecol Oncol*76:320-325.
- Saldanha SA, Kaler G, Cottam HB, Abagyan R and Taylor SS (2006) Assay principle for modulators of protein-protein interactions and its application to non-ATP-competitive ligands targeting protein kinase A. *Anal Chem*78:8265-8272.
- Sample V, DiPilato LM, Yang JH, Ni Q, Saucerman JJ and Zhang J (2012) Regulation of nuclear PKA revealed by spatiotemporal manipulation of cyclic AMP. *Nat Chem Biol*8:375-382.
- Sanchez JN, Wang T and Cohen MS (2018) BRAF and MEK Inhibitors: Use and Resistance in BRAF-Mutated Cancers. *Drugs*78:549-566.
- Sanchez-Collado J, Lopez JJ, Jardin I, Salido GM and Rosado JA (2021) Cross-Talk Between the Adenylyl Cyclase/cAMP Pathway and Ca(2+) Homeostasis. *Rev Physiol Biochem Pharmacol*179:73-116.
- Santoro M and Carlomagno F (2013) Central role of RET in thyroid cancer. *Cold Spring Harb Perspect Biol*5:a009233.
- Santos R, Ursu O, Gaulton A, Bento AP, Donadi RS, Bologa CG, Karlsson A, Al-Lazikani B, Hersey A, Oprea TI and Overington JP (2017) A comprehensive map of molecular drug targets. *Nat Rev Drug Discov*16:19-34.
- Sato T and Clevers H (2013) Primary mouse small intestinal epithelial cell cultures. *Methods Mol Biol*945:319-328.
- Sato T, Vries RG, Snippert HJ, van de Wetering M, Barker N, Stange DE, van Es JH, Abo A, Kujala P, Peters PJ and Clevers H (2009) Single Lgr5 stem cells build crypt-villus structures in vitro without a mesenchymal niche. *Nature*459:262-265.
- Schächterle C, Christian F, Fernandes JM and Klussmann E (2015) Screening for small molecule disruptors of AKAP-PKA interactions. *Methods Mol Biol*1294:151-166.
- Schell MJ, Yang M, Teer JK, Lo FY, Madan A, Coppola D, Monteiro ANA, Nebozhyn MV, Yue B, Loboda A, Bien-Willner GA, Greenawalt DM and Yeatman TJ (2016) A multigene mutation classification of 468 colorectal cancers reveals a prognostic role for APC. *Nat Commun*7:11743-11743.
- Schiavone MB, Herzog TJ, Lewin SN, Deutsch I, Sun X, Burke WM and Wright JD (2011) Natural history and outcome of mucinous carcinoma of the ovary. *Am J Obstet Gynecol*205:480.e481-488.
- Schindler RFR and Brand T (2016) The Popeye domain containing protein family--A novel class of cAMP effectors with important functions in multiple tissues. *Prog Biophys Mol Biol*120:28-36.
- Schmid A, Meili D and Salathe M (2014) Soluble adenylyl cyclase in health and disease. *Biochim Biophys Acta*1842:2584-2592.

- Schou KB, Pedersen LB and Christensen ST (2015) Ins and outs of GPCR signaling in primary cilia. *EMBO Rep*16:1099-1113.
- Schwede F, Chepurny OG, Kaufholz M, Bertinetti D, Leech CA, Cabrera O, Zhu Y, Mei F, Cheng X, Manning Fox JE, MacDonald PE, Genieser H-G, Herberg FW and Holz GG (2015) Rp-cAMPS Prodrugs Reveal the cAMP Dependence of First-Phase Glucose-Stimulated Insulin Secretion. *Mol Endocrinol*29:988-1005.
- Schwede F, Christensen A, Liauw S, Hippe T, Kopperud R, Jastorff B and Døskeland SO (2000) 8-Substituted cAMP analogues reveal marked differences in adaptability, hydrogen bonding, and charge accommodation between homologous binding sites (AI/AII and BI/BII) in cAMP kinase I and II. *Biochemistry*39:8803-8812.
- Seamon KB, Padgett W and Daly JW (1981) Forskolin: unique diterpene activator of adenylate cyclase in membranes and in intact cells. *Proc Natl Acad Sci U S A*78:3363-3367.
- SEER (2021) SEER Cancer Statistics Review (CSR) 1975-2018, National Cancer Institute.
- Seifert R, Wenzel-Seifert K, Lee TW, Gether U, Sanders-Bush E and Kobilka BK (1998) Different effects of G α splice variants on beta2-adrenoreceptor-mediated signaling. The Beta2-adrenoreceptor coupled to the long splice variant of G α has properties of a constitutively active receptor. *J Biol Chem*273:5109-5116.
- Seino S and Shibasaki T (2005) PKA-dependent and PKA-independent pathways for cAMP-regulated exocytosis. *Physiol Rev*85:1303-1342.
- Selberg S, Blokhina D, Aatonen M, Koivisto P, Siltanen A, Mervaala E, Kankuri E and Karelson M (2019) Discovery of Small Molecules that Activate RNA Methylation through Cooperative Binding to the METTL3-14-WTAP Complex Active Site. *Cell Rep*26:3762-3771.e3765.
- Sengupta R, Dubuc A, Ward S, Yang L, Northcott P, Woerner BM, Kroll K, Luo J, Taylor MD, Wechsler-Reya RJ and Rubin JB (2012) CXCR4 Activation Defines a New Subgroup of Sonic Hedgehog–Driven Medulloblastoma. *Cancer Res*72:122-132.
- Shannon P, Markiel A, Ozier O, Baliga NS, Wang JT, Ramage D, Amin N, Schwikowski B and Ideker T (2003) Cytoscape: a software environment for integrated models of biomolecular interaction networks. *Genome Res*13:2498-2504.
- Sharma ST, Nieman LK and Feelders RA (2015) Cushing's syndrome: epidemiology and developments in disease management. *Clin Epidemiol*7:281-293.
- Shi J and Vakoc CR (2014) The mechanisms behind the therapeutic activity of BET bromodomain inhibition. *Mol Cell*54:728-736.
- Shiota G, Okubo M, Noumi T, Noguchi N, Oyama K, Takano Y, Yashima K, Kishimoto Y and Kawasaki H (1999) Cyclooxygenase-2 expression in hepatocellular carcinoma. *Hepatogastroenterology*46:407-412.

- Shirley MD, Tang H, Gallione CJ, Baugher JD, Frelin LP, Cohen B, North PE, Marchuk DA, Comi AM and Pevsner J (2013) Sturge-Weber syndrome and port-wine stains caused by somatic mutation in GNAQ. *N Engl J Med*368:1971-1979.
- Silve C, Le-Stunff C, Motte E, Gunes Y, Linglart A and Clauser E (2012) Acrodysostosis syndromes. *Bonekey Rep*1:225-225.
- Singhi AD, Wood LD, Parks E, Torbenson MS, Felsenstein M, Hruban RH, Nikiforova MN, Wald AI, Kaya C, Nikiforov YE, Favazza L, He J, McGrath K, Fasanella KE, Brand RE, Lennon AM, Furlan A, Dasyam AK, Zureikat AH, Zeh HJ, Lee K, Bartlett DL and Slivka A (2020) Recurrent Rearrangements in PRKACA and PRKACB in Intraductal Oncocytic Papillary Neoplasms of the Pancreas and Bile Duct. *Gastroenterology*158:573-582.e572.
- Skalhegg BS and Tasken K (2000) Specificity in the cAMP/PKA signaling pathway. Differential expression, regulation, and subcellular localization of subunits of PKA. *Front Biosci*5:D678-693.
- Skålhegg BS, Huang Y, Su T, Idzerda RL, McKnight GS and Burton KA (2002) Mutation of the C α Subunit of PKA Leads to Growth Retardation and Sperm Dysfunction. *Mol Endocrinol*16:630-639.
- Skieterska K, Rondou P and Van Craenenbroeck K (2017) Regulation of G Protein-Coupled Receptors by Ubiquitination. *Int J Mol Sci*18:923.
- Skroblin P, Grossmann S, Schäfer G, Rosenthal W and Klussmann E (2010) Chapter Five - Mechanisms of Protein Kinase A Anchoring, in *Int Rev Cell Mol Biol* (Jeon K ed) pp 235-330, Academic Press.
- Smith FD, Esseltine JL, Nygren PJ, Veessler D, Byrne DP, Vonderach M, Strashnov I, Eysers CE, Eysers PA, Langeberg LK and Scott JD (2017) Local protein kinase A action proceeds through intact holoenzymes. *Science*356:1288-1293.
- Søberg K and Skålhegg BS (2018) The Molecular Basis for Specificity at the Level of the Protein Kinase a Catalytic Subunit. *Front Endocrinol (Lausanne)*9.
- Søberg K, Moen LV, Skålhegg BS and Laerdahl JK (2017) Evolution of the cAMP-dependent protein kinase catalytic subunit isoforms. *PLoS One*12:e0181091.
- Sonntag T, Ostojić J, Vaughan JM, Moresco JJ, Yoon Y-S, Yates JR and Montminy M (2019) Mitogenic Signals Stimulate the CREB Coactivator CRT3 through PP2A Recruitment. *iScience*11:134-145.
- Sprang SR (2016) Invited review: Activation of G proteins by GTP and the mechanism of G α -catalyzed GTP hydrolysis. *Biopolymers*105:449-462.
- Steffensen C, Bak AM, Zøylner Rubeck K and Jørgensen JOL (2010) Epidemiology of Cushing's Syndrome. *Neuroendocrinology*92(suppl 1):1-5.
- Stehelin D, Varmus HE, Bishop JM and Vogt PK (1976) DNA related to the transforming gene(s) of avian sarcoma viruses is present in normal avian DNA. *Nature*260:170-173.

- Stephenson A, Eszlinger M, Stewardson P, McIntyre JB, Boesenberg E, Bircan R, Sancak S, Gozu HI, Ghaznavi S, Krohn K and Paschke R (2020) Sensitive sequencing analysis suggests TSHR and GNAS as sole driver mutations in hot thyroid nodules. *Thyroid*30:1482-1489.
- Stratakis CA, Kirschner LS and Carney JA (2001) Clinical and Molecular Features of the Carney Complex: Diagnostic Criteria and Recommendations for Patient Evaluation. *J Clin Endocrinol Metab*86:4041-4046.
- Sunahara RK, Tesmer JJG, Gilman AG and Sprang SR (1997) Crystal Structure of the Adenylyl Cyclase Activator G α . *Science*278:1943-1947.
- Sunitsch S, Gilg MM, Kashofer K, Gollowitsch F, Leithner A and Liegl-Atzwanger B (2018) Detection of GNAS mutations in intramuscular / cellular myxomas as diagnostic tool in the classification of myxoid soft tissue tumors. *Diagn Pathol*13:52.
- Sutherland EW and Rall TW (1958) Fractionation and characterization of a cyclic adenine ribonucleotide formed by tissue particles. *J Biol Chem*232:1077-1091.
- Swords F, Noon L, King P and Clark A (2004) Constitutive activation of the human ACTH receptor resulting from a synergistic interaction between two naturally occurring missense mutations in the MC2R gene. *Mol Cell Endocrinol*213:149-154.
- Szklarczyk D, Gable AL, Lyon D, Junge A, Wyder S, Huerta-Cepas J, Simonovic M, Doncheva NT, Morris JH, Bork P, Jensen LJ and Mering CV (2019) STRING v11: protein-protein association networks with increased coverage, supporting functional discovery in genome-wide experimental datasets. *Nucleic Acids Res*47:D607-d613.
- Take Y, Koizumi S and Nagahisa A (2020) Prostaglandin E Receptor 4 Antagonist in Cancer Immunotherapy: Mechanisms of Action. *Front Immunol*11.
- Tate JG, Bamford S, Jubb HC, Sondka Z, Beare DM, Bindal N, Boutselakis H, Cole CG, Creatore C, Dawson E, Fish P, Harsha B, Hathaway C, Jupe SC, Kok CY, Noble K, Ponting L, Ramshaw CC, Rye CE, Speedy HE, Stefancsik R, Thompson SL, Wang S, Ward S, Campbell PJ and Forbes SA (2018) COSMIC: the Catalogue Of Somatic Mutations In Cancer. *Nucleic Acids Res*47:D941-D947.
- Taylor SS, Ilouz R, Zhang P and Kornev AP (2012) Assembly of allosteric macromolecular switches: lessons from PKA. *Nat Rev Mol Cell Biol*13:646-658.
- Taylor SS, Wallbott M, Machal EMF, Søberg K, Ahmed F, Bruystens J, Vu L, Baker B, Wu J, Raimondi F, Onger EM, Herberg FW and Skålhegg BS (2021) PKA C β : a forgotten catalytic subunit of cAMP-dependent protein kinase opens new windows for PKA signaling and disease pathologies. *Biochem J*478:2101-2119.
- Tengholm A and Gylfe E (2017) cAMP signalling in insulin and glucagon secretion. *Diabetes, Obesity and Metabolism*19:42-53.
- Teo G, Liu G, Zhang J, Nesvizhskii AI, Gingras AC and Choi H (2014) SAINTexpress: improvements and additional features in Significance Analysis of INTERactome software. *J Proteomics*100:37-43.

- Tidyman WE and Rauen KA (2009) The RASopathies: developmental syndromes of Ras/MAPK pathway dysregulation. *Curr Opin Genet Dev*19:230-236.
- Tilley SK and Fry RC (2015) Chapter 10 - Hormone Response Pathways as Responders to Environmental Contaminants and Their Roles in Disease, in *Systems Biology in Toxicology and Environmental Health* (Fry RC ed) pp 225-238, Academic Press, Boston.
- Tong D, Liu Q, Wang L-a, Xie Q, Pang J, Huang Y, Wang L, Liu G, Zhang D, Lan W and Jiang J (2018) The roles of the COX2/PGE2/EP axis in therapeutic resistance. *Cancer Metastasis Rev*37:355-368.
- Torres-Quesada O, Mayrhofer JE and Stefan E (2017) The many faces of compartmentalized PKA signalosomes. *Cell Signal*37:1-11.
- Tresguerres M, Levin LR and Buck J (2011) Intracellular cAMP signaling by soluble adenylyl cyclase. *Kidney Int*79:1277-1288.
- Tschaikner P, Enzler F, Torres-Quesada O, Aanstad P and Stefan E (2020) Hedgehog and Gpr161: Regulating cAMP Signaling in the Primary Cilium. *Cells*9:118.
- Tucker ON, Dannenberg AJ, Yang EK, Zhang F, Teng L, Daly JM, Soslow RA, Masferrer JL, Woerner BM, Koki AT and Fahey TJ (1999) Cyclooxygenase-2 Expression Is Up-Regulated in Human Pancreatic Cancer. *Cancer Res*59:987-990.
- Turan S and Bastepe M (2015) GNAS Spectrum of Disorders. *Curr Osteoporos Rep*13:146-158.
- Turnham RE and Scott JD (2016) Protein kinase A catalytic subunit isoform PRKACA; History, function and physiology. *Gene*577:101-108.
- Turnham RE, Smith FD, Kenerson HL, Omar MH, Golkowski M, Garcia I, Bauer R, Lau H-T, Sullivan KM, Langeberg LK, Ong S-E, Riehle KJ, Yeung RS and Scott JD (2019) An acquired scaffolding function of the DNAJ-PKAc fusion contributes to oncogenic signaling in fibrolamellar carcinoma. *eLife*8:e44187.
- Unson CG, Wu C-R, Sakmar TP and Merrifield RB (2000) Selective Stabilization of the High Affinity Binding Conformation of Glucagon Receptor by the Long Splice Variant of G α s. *J Biol Chem*275:21631-21638.
- Valenta T, Hausmann G and Basler K (2012) The many faces and functions of β -catenin. *EMBO J*31:2714-2736.
- Van Nostrand EL, Freese P, Pratt GA, Wang X, Wei X, Xiao R, Blue SM, Chen J-Y, Cody NAL, Dominguez D, Olson S, Sundararaman B, Zhan L, Bazile C, Bouvrette LPB, Bergalet J, Duff MO, Garcia KE, Gelboin-Burkhart C, Hochman M, Lambert NJ, Li H, McGurk MP, Nguyen TB, Palden T, Rabano I, Sathe S, Stanton R, Su A, Wang R, Yee BA, Zhou B, Louie AL, Aigner S, Fu X-D, Lécuyer E, Burge CB, Graveley BR and Yeo GW (2020) A large-scale binding and functional map of human RNA-binding proteins. *Nature*583:711-719.
- Vander Heiden MG, Cantley LC and Thompson CB (2009) Understanding the Warburg Effect: The Metabolic Requirements of Cell Proliferation. *Science*324:1029-1033.

- Vannam R, Sayilgan J, Ojeda S, Karakyriakou B, Hu E, Kreuzer J, Morris R, Herrera Lopez XI, Rai S, Haas W, Lawrence M and Ott CJ (2021) Targeted degradation of the enhancer lysine acetyltransferases CBP and p300. *Cell Chemical Biology*28:503-514.e512.
- Vasioukhin V, Degenstein L, Wise B and Fuchs E (1999) The magical touch: genome targeting in epidermal stem cells induced by tamoxifen application to mouse skin. *Proc Natl Acad Sci U S A*96:8551-8556.
- Velcich A, Yang W, Heyer J, Fragale A, Nicholas C, Viani S, Kucherlapati R, Lipkin M, Yang K and Augenlicht L (2002) Colorectal cancer in mice genetically deficient in the mucin Muc2. *Science*295:1726-1729.
- VerPlank JJS, Lokireddy S, Zhao J and Goldberg AL (2019) 26S Proteasomes are rapidly activated by diverse hormones and physiological states that raise cAMP and cause Rpn6 phosphorylation. *Proc Natl Acad Sci U S A*116:4228-4237.
- Veugelers M, Wilkes D, Burton K, McDermott DA, Song Y, Goldstein MM, La Perle K, Vaughan CJ, O'Hagan A, Bennett KR, Meyer BJ, Legius E, Karttunen M, Norio R, Kaariainen H, Lavyne M, Neau JP, Richter G, Kirali K, Farnsworth A, Stapleton K, Morelli P, Takanashi Y, Bamforth JS, Eitelberger F, Noszian I, Manfroi W, Powers J, Mochizuki Y, Imai T, Ko GT, Driscoll DA, Goldmuntz E, Edelberg JM, Collins A, Eccles D, Irvine AD, McKnight GS and Basson CT (2004) Comparative PRKAR1A genotype-phenotype analyses in humans with Carney complex and prkar1a haploinsufficient mice. *Proc Natl Acad Sci U S A*101:14222-14227.
- Visscher M, Arkin MR and Dansen TB (2016) Covalent targeting of acquired cysteines in cancer. *Curr Opin Chem Biol*30:61-67.
- Visser SS, Theron AJ, Ramafi G, Ker JA and Anderson R (2000) Apparent involvement of the A(2A) subtype adenosine receptor in the anti-inflammatory interactions of CGS 21680, cyclopentyladenosine, and IB-MECA with human neutrophils. *Biochem Pharmacol*60:993-999.
- Vitale-Cross L, Amornphimoltham P, Fisher G, Molinolo AA and Gutkind JS (2004) Conditional expression of K-ras in an epithelial compartment that includes the stem cells is sufficient to promote squamous cell carcinogenesis. *Cancer Res*64:8804-8807.
- Vogelstein B, Papadopoulos N, Velculescu VE, Zhou S, Diaz LA and Kinzler KW (2013) Cancer Genome Landscapes. *Science*339:1546-1558.
- Vyas M, Hechtman JF, Zhang Y, Benayed R, Yavas A, Askan G, Shia J, Klimstra DS and Basturk O (2020) DNAJB1-PRKACA fusions occur in oncocytic pancreatic and biliary neoplasms and are not specific for fibrolamellar hepatocellular carcinoma. *Mod Pathol*33:648-656.
- Wainger BJ, DeGennaro M, Santoro B, Siegelbaum SA and Tibbs GR (2001) Molecular mechanism of cAMP modulation of HCN pacemaker channels. *Nature*411:805-810.
- Walczak EM and Hammer GD (2015) Regulation of the adrenocortical stem cell niche: implications for disease. *Nat Rev Endocrinol*11:14-28.

- Walker C, Wang Y, Olivieri C, Karamafrooz A, Casby J, Bathon K, Calebiro D, Gao J, Bernlohr DA, Taylor SS and Veglia G (2019) Cushing's syndrome driver mutation disrupts protein kinase A allosteric network, altering both regulation and substrate specificity. *Sci Adv*5:eaaw9298-eaaw9298.
- Walsh DA, Perkins JP and Krebs EG (1968) An Adenosine 3',5'-Monophosphate-dependant Protein Kinase from Rabbit Skeletal Muscle. *J Biol Chem*243:3763-3765.
- Wang D and DuBois RN (2010) The role of COX-2 in intestinal inflammation and colorectal cancer. *Oncogene*29:781-788.
- Wang J, Gareri C and Rockman HA (2018) G-Protein-Coupled Receptors in Heart Disease. *Circ Res*123:716-735.
- Wang L, Wang Q, Zhou Y, Xue Q, Sun X, Wang Z and Ji G (2018) Recurrent left atrial myxoma in Carney complex: A case report of a familial pedigree. *Medicine (Baltimore)*97:e0247.
- Wang S, Li Z, Shen H, Zhang Z, Yin Y, Wang Q, Zhao X and Ji J (2016) Quantitative Phosphoproteomic Study Reveals that Protein Kinase A Regulates Neural Stem Cell Differentiation Through Phosphorylation of Catenin Beta-1 and Glycogen Synthase Kinase 3 β . *Stem Cells*34:2090-2101.
- Wang Y, Ho TG, Bertinetti D, Neddermann M, Franz E, Mo GCH, Schendowich LP, Sukhu A, Spelts RC, Zhang J, Herberg FW and Kennedy EJ (2014) Isoform-Selective Disruption of AKAP-Localized PKA Using Hydrocarbon Stapled Peptides. *ACS Chem Biol*9:635-642.
- Wang Y, Ho TG, Franz E, Hermann JS, Smith FD, Hehnlly H, Esseltine JL, Hanold LE, Murph MM, Bertinetti D, Scott JD, Herberg FW and Kennedy EJ (2015) PKA-Type I Selective Constrained Peptide Disruptors of AKAP Complexes. *ACS Chem Biol*10:1502-1510.
- Waters AM and Der CJ (2018) KRAS: The Critical Driver and Therapeutic Target for Pancreatic Cancer. *Cold Spring Harb Perspect Med*8.
- Wehbi VL and Taskén K (2016) Molecular Mechanisms for cAMP-Mediated Immunoregulation in T cells - Role of Anchored Protein Kinase A Signaling Units. *Front Immunol*7:222-222.
- Weidensdorfer D, Stöhr N, Baude A, Lederer M, Köhn M, Schierhorn A, Buchmeier S, Wahle E and Hüttelmaier S (2009) Control of c-myc mRNA stability by IGF2BP1-associated cytoplasmic RNPs. *RNA (New York, NY)*15:104-115.
- Weinstein LS, Liu J, Sakamoto A, Xie T and Chen M (2004) Minireview: GNAS: normal and abnormal functions. *Endocrinology*145:5459-5464.
- Welch EJ, Jones BW and Scott JD (2010) Networking with AKAPs: context-dependent regulation of anchored enzymes. *Mol Interv*10:86-97.
- Wendell SG, Fan H and Zhang C (2020) G Protein-Coupled Receptors in Asthma Therapy: Pharmacology and Drug Action. *Pharmacol Rev*72:1-49.

- Wiley SZ, Sriram K, Liang W, Chang SE, French R, McCann T, Sicklick J, Nishihara H, Lowy AM and Insel PA (2018) GPR68, a proton-sensing GPCR, mediates interaction of cancer-associated fibroblasts and cancer cells. *FASEB J*32:1170-1183.
- Willis BS, Niswender CM, Su T, Amieux PS and McKnight GS (2011) Cell-type specific expression of a dominant negative PKA mutation in mice. *PLoS One*6:e18772-e18772.
- Wilson CH, McIntyre RE, Arends MJ and Adams DJ (2010) The activating mutation R201C in GNAS promotes intestinal tumourigenesis in Apc(Min/+) mice through activation of Wnt and ERK1/2 MAPK pathways. *Oncogene*29:4567-4575.
- Wong TH, Chiu WZ, Breedveld GJ, Li KW, Verkerk AJMH, Hondius D, Hukema RK, Seelaar H, Frick P, Severijnen L-A, Lammers G-J, Lebbink JHG, van Duinen SG, Kamphorst W, Rozemuller AJ, Bank NB, Bakker EB, Network TIPG, Neumann M, Willemsen R, Bonifati V, Smit AB and van Swieten J (2014) PRKAR1B mutation associated with a new neurodegenerative disorder with unique pathology. *Brain*137:1361-1373.
- Wong W and Scott JD (2004) AKAP signalling complexes: focal points in space and time. *Nat Rev Mol Cell Biol*5:959-970.
- Wu J, Brown SH, von Daake S and Taylor SS (2007) PKA type IIalpha holoenzyme reveals a combinatorial strategy for isoform diversity. *Science*318:274-279.
- Wu V, Yeerna H, Nohata N, Chiou J, Harismendy O, Raimondi F, Inoue A, Russell RB, Tamayo P and Gutkind JS (2019) Illuminating the Onco-GPCRome: Novel G protein-coupled receptor-driven oncocrine networks and targets for cancer immunotherapy. *J Biol Chem*294:11062-11086.
- Xie G-D, Liu Y-R, Jiang Y-Z and Shao Z-M (2018) Epidemiology and survival outcomes of mucinous adenocarcinomas: A SEER population-based study. *Sci Rep*8:6117.
- Xie J, Lee J-A, Kress TL, Mowry KL and Black DL (2003) Protein kinase A phosphorylation modulates transport of the polypyrimidine tract-binding protein. *Proc Natl Acad Sci U S A*100:8776-8781.
- Xu Y and Vakoc CR (2017) Targeting Cancer Cells with BET Bromodomain Inhibitors. *Cold Spring Harb Perspect Med*7:a026674.
- Yamada M, Sekine S, Ogawa R, Taniguchi H, Kushima R, Tsuda H and Kanai Y (2012) Frequent activating GNAS mutations in villous adenoma of the colorectum. *J Pathol*228:113-118.
- Yang H and Yang L (2016) Targeting cAMP/PKA pathway for glycemic control and type 2 diabetes therapy. *J Mol Endocrinol*57:R93-r108.
- Ye Q, Qi F, Bian L, Zhang SH, Wang T and Jiang ZF (2017) Circulating-free DNA Mutation Associated with Response of Targeted Therapy in Human Epidermal Growth Factor Receptor 2-positive Metastatic Breast Cancer. *Chin Med J (Engl)*130:522-529.
- Yonemoto W, McGlone ML, Grant B and Taylor SS (1997) Autophosphorylation of the catalytic subunit of cAMP-dependent protein kinase in Escherichia coli. *Protein Eng*10:915-925.

- Young A, Mittal D, Stagg J and Smyth MJ (2014) Targeting cancer-derived adenosine: new therapeutic approaches. *Cancer Discov*4:879-888.
- Young A, Ngiow SF, Gao Y, Patch AM, Barkauskas DS, Messaoudene M, Lin G, Coudert JD, Stannard KA, Zitvogel L, Degli-Esposti MA, Vivier E, Waddell N, Linden J, Huntington ND, Souza-Fonseca-Guimaraes F and Smyth MJ (2018) A2AR Adenosine Signaling Suppresses Natural Killer Cell Maturation in the Tumor Microenvironment. *Cancer Res*78:1003-1016.
- Yu FX, Zhang Y, Park HW, Jewell JL, Chen Q, Deng Y, Pan D, Taylor SS, Lai ZC and Guan KL (2013) Protein kinase A activates the Hippo pathway to modulate cell proliferation and differentiation. *Genes Dev*27:1223-1232.
- Yu FX, Zhao B, Panupinthu N, Jewell JL, Lian I, Wang LH, Zhao J, Yuan H, Tumaneng K, Li H, Fu XD, Mills GB and Guan KL (2012) Regulation of the Hippo-YAP pathway by G-protein-coupled receptor signaling. *Cell*150:780-791.
- Yu S, Yu D, Lee E, Eckhaus M, Lee R, Corria Z, Accili D, Westphal H and Weinstein LS (1998) Variable and tissue-specific hormone resistance in heterotrimeric Gs protein alpha-subunit (G α) knockout mice is due to tissue-specific imprinting of the g α gene. *Proc Natl Acad Sci U S A*95:8715-8720.
- Zagotta WN and Siegelbaum SA (1996) Structure and function of cyclic nucleotide-gated channels. *Annu Rev Neurosci*19:235-263.
- Zauber P, Marotta SP and Sabbath-Solitare M (2016) GNAS gene mutation may be present only transiently during colorectal tumorigenesis. *Int J Mol Epidemiol Genet*7:24-31.
- Zehir A, Benayed R, Shah RH, Syed A, Middha S, Kim HR, Srinivasan P, Gao J, Chakravarty D, Devlin SM, Hellmann MD, Barron DA, Schram AM, Hameed M, Dogan S, Ross DS, Hechtman JF, DeLair DF, Yao J, Mandelker DL, Cheng DT, Chandramohan R, Mohanty AS, Ptashkin RN, Jayakumaran G, Prasad M, Syed MH, Rema AB, Liu ZY, Nafa K, Borsu L, Sadowska J, Casanova J, Bacares R, Kiecka IJ, Razumova A, Son JB, Stewart L, Baldi T, Mullaney KA, Al-Ahmadie H, Vakiani E, Abeshouse AA, Penson AV, Jonsson P, Camacho N, Chang MT, Won HH, Gross BE, Kundra R, Heins ZJ, Chen HW, Phillips S, Zhang H, Wang J, Ochoa A, Wills J, Eubank M, Thomas SB, Gardos SM, Reales DN, Galle J, Durany R, Cambria R, Abida W, Cercek A, Feldman DR, Gounder MM, Hakimi AA, Harding JJ, Iyer G, Janjigian YY, Jordan EJ, Kelly CM, Lowery MA, Morris LGT, Omuro AM, Raj N, Razavi P, Shoushtari AN, Shukla N, Soumerai TE, Varghese AM, Yaeger R, Coleman J, Bochner B, Riely GJ, Saltz LB, Scher HI, Sabbatini PJ, Robson ME, Klimstra DS, Taylor BS, Baselga J, Schultz N, Hyman DM, Arcila ME, Solit DB, Ladanyi M and Berger MF (2017) Mutational landscape of metastatic cancer revealed from prospective clinical sequencing of 10,000 patients. *Nat Med*23:703-713.
- Zelenay S, van der Veen AG, Bottcher JP, Snelgrove KJ, Rogers N, Acton SE, Chakravarty P, Girotti MR, Marais R, Quezada SA, Sahai E and Reis e Sousa C (2015) Cyclooxygenase-Dependent Tumor Growth through Evasion of Immunity. *Cell*162:1257-1270.
- Zhang JZ, Lu T-W, Stolerman LM, Tenner B, Yang JR, Zhang J-F, Falcke M, Rangamani P, Taylor SS, Mehta S and Zhang J (2020) Phase Separation of a PKA Regulatory Subunit Controls cAMP Compartmentation and Oncogenic Signaling. *Cell*182:1531-1544.e1515.

- Zhang JZ, Lu T-W, Stoleran LM, Tenner B, Yang JR, Zhang J-F, Falcke M, Rangamani P, Taylor SS, Mehta S and Zhang J (2020) Phase Separation of a PKA Regulatory Subunit Controls cAMP Compartmentation and Oncogenic Signaling. *Cell*182:1531-1544.e1515.
- Zhang X, Odom DT, Koo SH, Conkright MD, Canetti G, Best J, Chen H, Jenner R, Herbolsheimer E, Jacobsen E, Kadam S, Ecker JR, Emerson B, Hogenesch JB, Unterman T, Young RA and Montminy M (2005) Genome-wide analysis of cAMP-response element binding protein occupancy, phosphorylation, and target gene activation in human tissues. *Proc Natl Acad Sci U S A*102:4459-4464.
- Zhao X, Deng P, Iglesias-Bartolome R, Amornphimoltham P, Steffen DJ, Jin Y, Molinolo AA, de Castro LF, Ovejero D, Yuan Q, Chen Q, Han X, Bai D, Taylor SS, Yang Y, Collins MT and Gutkind JS (2018) Expression of an active G α (s) mutant in skeletal stem cells is sufficient and necessary for fibrous dysplasia initiation and maintenance. *Proc Natl Acad Sci U S A*115:E428-e437.
- Zhou XY, Shibusawa N, Naik K, Porras D, Temple K, Ou H, Kaihara K, Roe MW, Brady MJ and Wondisford FE (2004) Insulin regulation of hepatic gluconeogenesis through phosphorylation of CREB-binding protein. *Nat Med*10:633-637.
- Zimmermann KC, Sarbia M, Weber A-A, Borchard F, Gabbert HE and Schrör K (1999) Cyclooxygenase-2 Expression in Human Esophageal Carcinoma. *Cancer Res*59:198-204.
- Zimmermannova O, Doktorova E, Stuchly J, Kanderova V, Kuzilkova D, Strnad H, Starkova J, Alberich-Jorda M, Falkenburg JHF, Trka J, Petrak J, Zuna J and Zaliova M (2017) An activating mutation of GNB1 is associated with resistance to tyrosine kinase inhibitors in ETV6-ABL1-positive leukemia. *Oncogene*36:5985-5994.