

Lawrence Berkeley National Laboratory

LBL Dissertations

Title

EXPLOITATION OF THE SMALL PION MASS IN MULTI-REGGE THEORY

Permalink

<https://escholarship.org/uc/item/99h2t95z>

Author

Shankar, R.

Publication Date

1974-04-01

Thesis/dissertation

RECEIVED
LAWRENCE
RADIATION LABORATORY

LBL-2640
c.2

JUN 27 1974

LIBRARY AND
DOCUMENTS SECTION

EXPLOITATION OF THE SMALL PION MASS
IN MULTI-REGGE THEORY

R. Shankar
(Ph.D. thesis)

April 26, 1974

Prepared for the U. S. Atomic Energy Commission
under Contract W-7405-ENG-48



LBL-2640
c.2

DISCLAIMER

This document was prepared as an account of work sponsored by the United States Government. While this document is believed to contain correct information, neither the United States Government nor any agency thereof, nor the Regents of the University of California, nor any of their employees, makes any warranty, express or implied, or assumes any legal responsibility for the accuracy, completeness, or usefulness of any information, apparatus, product, or process disclosed, or represents that its use would not infringe privately owned rights. Reference herein to any specific commercial product, process, or service by its trade name, trademark, manufacturer, or otherwise, does not necessarily constitute or imply its endorsement, recommendation, or favoring by the United States Government or any agency thereof, or the Regents of the University of California. The views and opinions of authors expressed herein do not necessarily state or reflect those of the United States Government or any agency thereof or the Regents of the University of California.

EXPLOITATION OF THE SMALL PION MASS IN MULTI-REGGE THEORY

R. Shankar

CONTENTS

	<u>Page</u>
Abstract	iii
Introduction	v
Chapter I: A Clarification of Multi-Regge Theory.	1
Chapter II: Can and Does the Pomeron Occur More Than Once in a Single Process?	21
Chapter III: Criticism of the $P' - \omega$ Exchange Degeneracy Arguments on the $pp \rightarrow pX$ Triple-Regge Region.	68
Chapter IV: Role of the Pion Mass in Triple-Regge Physics.	77
Acknowledgments	106

EXPLOITATION OF THE SMALL PION MASS IN MULTI-REGGE THEORY

R. Shankar

Lawrence Berkeley Laboratory
University of California
Berkeley, California 94720

April 26, 1974

ABSTRACT

This dissertation is a collection of four papers which address themselves to problems in multi-Regge theory and lean heavily on the hypothesis of pion pole dominance in arriving at the solutions. The meaning of multi-Regge diagrams (whose superficial resemblance to Feynman diagrams seemed to be the source of some prevalent misconceptions) and the rules for manipulating the same are discussed in the first paper. The second provides an affirmative and quantitative answer to the question of whether or not the pomeron can and does occur more than once in the amplitude for a single process. The significant feature of the analysis, based on the pion pole dominance hypothesis, is that only the context in which the pomeron occurs (high energy diffractive amplitudes) is assumed and the result is independent of the specific J-plane singularity associated with the pomeron. The third and fourth papers deal with triple-Regge processes. In the former, the omission of off-diagonal coefficients ($G_{ijk}; i \neq j$) in triple-Regge fits to the data is criticized and the exchange degeneracy arguments adduced in support of the above omission are shown to be without basis in the triple-Regge region. Calculations within the pion pole dominance model are presented to show that one of the omitted off-diagonal coefficients could possibly be responsible for a

substantial fraction (typically 30%) of the inclusive cross section. In the final paper, the salient features of the measured diagonal coefficients (G_{iik}) are correlated with the role of the pion mass in the triple-Regge region. In particular, the observed delay in the convergence of the triple-Regge expansion in the variable (S/M^2) describing the exclusive reggeons, resulting from the largeness of the coefficients G_{RRP} and G_{RRP} compared to G_{PPP} and G_{PPR} , is tied in with the circumstance that while the latter pair is independent of the pion mass the former is controlled by it in an essential way.

INTRODUCTION

The Principle of Nuclear Democracy, which proclaims that all poles of the S matrix are created equal, does not exclude the circumstance that the pion pole is more equal than others, by virtue of its strategic location. Before we go into what constitutes a strategic location, let us summarize the great simplification associated with the S-matrix poles: (i) The pole locations are decided by particle masses, and are hence generally known. (ii) The residues are sometimes known beforehand. For example, the residue of the pion pole in the amplitude for $a(p_a) + b(p_b) \rightarrow a(p_a') + b(p_b') + \pi^+(p_+) + \pi^-(p_-)$ at $t = (p_a + p_+ - p_a')^2 = \mu^2$ (μ is the pion mass) is a product of $a\pi^+$ and $b\pi^-$ elastic amplitudes.

Between us and this simplification stands the gap separating the physical region (to which we are confined) and the pole location.⁺ For a pole in the crossed channel invariant (which we will call t) this separation has a minimum value given by the mass squared of the corresponding exchanged particle. If the latter were a pion, which is by far the lightest hadron, the pole comes within $\approx 0.02 \text{ GeV}^2$ of the physical region in the t -plane. Since the other singularities are effectively⁺⁺ in the order of 1 GeV^2 away, one assumes that the pion

⁺ We are ignoring here the macrocausality poles that occur in the physical region of processes with three or more particles in the initial state.

⁺⁺ I use the word "effectively" to take into account certain weak singularities like the two pion branch point which come much closer than 1 GeV^2 . The significant discontinuities associated with such singularities are however in the order of 1 GeV^2 away.

pole controls the part of the physical region closest to it, bringing to the physical region the above mentioned simplifications otherwise confined to the pole location.

While skeptics argued that more distant singularities are not necessarily ignorable, others have dared to make the above assumption, called the pion pole dominance hypothesis, and have been led to a variety of interesting consequences ranging from the Chew-Low extrapolation of the earliest days to the multiperipheral models of Amati, Bertocchi, Fubini, Strangellini, and Tonin.

This dissertation is a collection of papers (presented in four chapters) which attack problems in multi-Regge theory, leaning heavily on the pion pole dominance hypothesis for guidance. The contents of these papers are briefly discussed in the preceding general Abstract and the Abstracts preceding each paper.

Hopefully the following pages will convince you that the hypothesis of pion pole dominance has by no means yielded its last result and that in the future it will lend itself to further exploitation.

CHAPTER I

A CLARIFICATION OF MULTI-REGGE THEORY

Physical Review D7 (1973), 3513

A CLARIFICATION OF MULTI-REGGE THEORY*

R. Shankar

Lawrence Berkeley Laboratory
University of California
Berkeley, California 94720

February 7, 1973

ABSTRACT

We are concerned here with the amplitude for the reaction $a + b \rightarrow 1 + 2 + \dots + N$. We assert that the prevalent notion of adding multi-Regge diagrams, corresponding to the different ordering of final particles, has no basis. Arguments supporting this assertion are followed by a list of rules for calculating cross sections. A sample of the literature that motivated this paper is briefly discussed.

I. INTRODUCTION

Many models have been proposed on the basis of a generalization of Regge theory from $2 \rightarrow 2$ reactions to $2 \rightarrow N$ reactions. We are concerned here with two concepts that seem widespread.

Concept A: The amplitude M , for the $2 \rightarrow N$ process, is a sum of amplitudes corresponding to all the multi-Regge diagrams related by a permutation of final particle legs.

Concept B: If A is accepted, the question of interference terms between the different terms arises. One finds arguments that either emphasize their insignificance or exploit their importance.

We argue here that concept A has no place in any theory that generalizes $2 \rightarrow 2$ Regge theory, by seeking asymptotic expansions of M in certain special regions of phase space. We shall, however, work within the framework of the Bali, Chew, and Pignotti (BCP)^{1,2} multi-Regge hypothesis, which seems to be the natural generalization of the "J plane" analyticity of $2 \rightarrow 2$ reactions. We shall show that concept A has no place in the implementation of this hypothesis. Concept A seems to be a result of the superficial resemblance that multi-Regge diagrams bear to Feynman diagrams.

In Sec. II we see how, and in what sense, multi-Regge diagrams approximate the actual amplitude, M . We dilate on those aspects that distinguish an asymptotic expansion within an S-matrix framework from perturbative expansions of field theory. Rules for calculating cross sections are discussed in Sec. III. In Sec. IV we discuss a sample of the literature where concepts A and B are employed. We have not specified whether the final particles are distinguishable, identical, or a mixture of both, since our assertion regarding concept

A is independent of this question. In what follows, however, it must be born in mind that we use the word "phase space" to mean ϕ_M , the mathematical phase space, in which the final particle momenta go over all the values allowed by energy momentum conservation. (We contrast ϕ_M with ϕ_0 , the observable phase space, in which the momenta of the final particles are restricted so that each distinguishable final state occurs just once).

II. THE MULTI-REGGE HYPOTHESIS OF BCP

We assume familiarity with Toller variables^{1,2} and deal only with certain special aspects that are germane to the issue. For concreteness, the reader may consider the $N = 2$ case, in what follows.

(i) Consider the amplitude M , for the process $a + b \rightarrow 1 + 2 + \dots + N$, involving spinless particles. Bali, Chew, and Pignotti^{1,2} explain how, by ordering the N particles in any arbitrary way, we can define the Toller variables. Figure 1 is the Toller diagram employed for this purpose. We emphasize that

(a) It is kinematical in nature and merely establishes a convention for the Toller variables.

(b) The ordering of particles in Fig. 1 is not their ordering in rapidity. The latter is decided by the values of the ω 's, ξ 's, and t 's. Thus, one Toller diagram and the set of variables defined by it, are all we need to span the entire phase space ϕ .

(c) No factorization of M is intended or implied.

We have then

$$M = M(t_{12}, t_{23}, \dots; \xi_{12}, \xi_{23}, \dots; \omega_2, \omega_3, \dots) = M(t_{12}, \dots; g_{12}, \dots)$$

where $g_{i,i+1}$ stands for the group variables of the i th link. We now expand the amplitude over the $O(2,1)$ group functions. In symbolic form (for brevity) we have

$$M(t_{12}, \dots; g_{12}, \dots) = \int d\ell^{12} d\ell^{23} \dots \chi d^{\ell^{12}}(g_{12}) d^{\ell^{23}}(g_{23}) \dots \\ \times B^{\ell^{12}, \ell^{23}, \dots}(t_{12}, t_{23}, \dots) \quad (1)$$

where, in Eq. (1), $\ell_{i,i+1}$ stands for the label of the irreducible representations of $O(2,1)$, the d 's are the group functions, and B is the "partial wave amplitude." (We are aware that the above symbolic form has suppressed the m, n indices, the contours in the ℓ planes etc.)

(ii) The multi-Regge hypothesis: "The amplitude B is an analytic function of the ℓ 's, with the rightmost singularity being a factorizable pole $\alpha_{i,i+1}(t_{i,i+1})$ in the $\ell_{i,i+1}$ plane." We are not interested in analyzing the validity of the above hypothesis, but rather in examining the consequences.

(iii) The above hypothesis, even if true, is useful only in special circumstances. For the ordering of particles in Fig. 1, there is one part of phase space where, as $s \rightarrow \infty$, we can have $t_{i,i+1}$ fixed, the subenergies $s_{i,i+1} \rightarrow \infty$; i.e., $\xi_{i,i+1} \rightarrow \infty$.^{1,2} In this region the particles will be ordered in rapidity as they are in Fig. 1 (see Fig 2). In such a region, the contributions from the

rightmost poles will dominate the l integrals, and we can write the famous expansion:

$$M(t_{12}, \dots; g_{12}, \dots) \xrightarrow{\text{all } \xi \rightarrow \infty} \beta_{a1}(t_{12}) (\cosh \xi_{12})^{\alpha_{12}(t_{12})} \dots$$

$$\times (\cosh \xi_{N-1,N})^{\alpha_{N-1,N}(t_{N-1,N})} \beta_{bN}(t_{N-1,N})$$

+ terms coming from the nonleading singularities of the l planes, whose effect is negligible in this part of space phase

$$= M_1^{(1)} + \text{neglected terms.} \quad (2)$$

In $M_1^{(1)}$, the subscript refers to the region of phase space, ϕ_1 , corresponding to this ordering of particles; while the superscript indicates that only the leading pole was retained in each expansion. We represent $M_1^{(1)}$ by a multi-Regge diagram (Fig. 3), (the origin of all this misunderstanding!), and remark that:

- (a) It is a dynamical diagram.
- (b) Factorization is implied.
- (c) Rapidity ordering of particles is as in diagram.

To calculate any cross section in this part of ϕ_1 , we can use $M_1^{(1)}$ instead of M , with little error. If we want, we can keep two poles, α and α' in each expansion (assuming the second leading singularity is a pole) to get $M_1^{(2)}$, which will be a sum of 2^{N-1} terms, each with its own diagram. Here the additivity is a consequence of Cauchy's theorem and not the superposition principle.

(iv) Consider now the part of phase space where the rapidity plot is as in Fig. 4. It is clear that the physics here is as simple as in Fig. 2. However, $t_{12} = (p_a - p_1)^2$ cannot be held fixed as $s_{12} \rightarrow \infty$. Therefore the Toller variables defined in Fig. 1 are undesirable, despite their formal completeness. An expansion in those variables will, at best, have poor convergence properties. (We cannot, asymptotically, call a few terms of the expansion as "leading" and ignore the rest.) To exploit the dynamical simplification in the situation, we must draw a new Toller diagram with particle ordering (2,1,3,4,5,...N). Then $\tilde{t}_{12} = (p_a - p_2)^2$ can be held fixed as $\tilde{s}_{12} \rightarrow \infty$ (so that $\tilde{\xi}_{12} \rightarrow \infty$) to yield:

$$M = \beta_{a2}(\tilde{t}_{12})(\tilde{s}_{12})^{\tilde{\alpha}(\tilde{t}_{12})} \beta(\tilde{t}_{12}, \tilde{\omega}_2, \tilde{t}_{23}) \cdots \beta_{Nb}(\tilde{t}_{N-1,N})$$

+ terms from neglected singularities . (3)

By our convention, the leading term is $M_2^{(1)}$. To calculate cross sections in this neighborhood, we can use $M_2^{(1)}$ or $M_2^{(2)}$ instead of M.

It is clear that in the $N!$ regions of phase space, $\phi_1, \phi_2, \dots, \phi_{N!}$, corresponding to the different orderings of final particles in rapidity, we must define $N!$ different Toller diagrams and $N!$ sets of Toller variables, in order to exploit the simplicity introduced by the multi-Regge hypothesis. The reason for permuting the legs is thus the need to set up new sets of Toller variables, and not the superposition or Bose principle. It is clear that nowhere does the theory require or admit the addition of one expansion, M_1 ,

of ϕ_i , to another, M_j , of ϕ_j ; of one and the same amplitude M . The different expansions are alternate and not additive. In ϕ_i we can use $M_i^{(1)}$ or $M_i^{(2)}$ but not $M_i^{(1)} + M_j^{(1)}$. Such an addition is an arbitrary recipe, and certainly not forced upon us by the superposition or Bose principles. In fact, these principles are not imposed on M by hand (as in perturbative field theories where M is built from little pieces), but are demanded of M in S-matrix Regge calculations, where one begins with the "complete" amplitude and seeks its asymptotic expansions.

These ideas are transparent in the $2 \rightarrow 2$, equal mass, case. The t - and u -channel expansions (not their leading pole approximations) M_t and M_u are each alternate, complete expansions of M . A choice between them is made when we wish to approximate M in some special regions of phase space. If we approximate M_t by the leading pole contribution $M_t^{(1)}$, we are assured that at any fixed t , as $s \rightarrow \infty$, $M_t^{(1)}$ will approach M to any given accuracy. In practice, when we work at fixed s , $M_t^{(1)}$ can be a poor approximation to M except for very small t . At larger t , if $M_t^{(1)}$ is a bad fit, we can try $M_t^{(2)}$ etc. While adding more t poles to M_t is not guaranteed to give better approximation, it is a legitimate process one can try. Similar results hold for M_u . By contrast, the process of adding some singularities of M_t to some of M_u , to get approximations for M , is a purely arbitrary recipe and not a consequence of the theory. The expansions, M_t and M_u , are dual and alternative, as M_s , the direct channel expansion (which may possibly be approximated by a few resonances) is dual to M_t , the cross channel Regge expansion (which may possibly be approximated by a few Regge poles). Fits to the data,

using an M constructed by adding t and u Regge poles, do not test the theory.

We similarly conclude that the following, oft-quoted recipe, for processes with identical particles in the final state, is also ad hoc, and not a consequence of the multi-Regge hypothesis:

Step 1: Calculate the multi-Regge amplitude M_i corresponding to one ordering of final particle momenta. (Then M_i approaches M in a sub-region of ϕ_i where the Regge limit is reached.)

Step 2: Set $M = \sum_i M_i$, where i runs through all the permutations of the identical particle momenta in the final state.

Though this recipe guarantees Bose statistics manifestly, the flaw in the argument is the following. Bose statistics merely requires that $M(A) = M(B)$, where A and B are two points in phase space, related by a permutation of identical bosons. There is, however, no requirement that M achieve this symmetry by the recipe $M = \sum_i M_i$.

We illustrate this point by considering a Veneziano-like amplitude, $B(u,t)$, for a fictitious $2 \rightarrow 2$ process where the s channel has identical particles and no resonances. Bose symmetry requires that if

$$B(u,t) \xrightarrow{(\lim u \rightarrow a, t=b)} \frac{F(b)}{u-a}$$

then we must have

$$B(u,t) \xrightarrow{(\lim t \rightarrow a, u=b)} \frac{F(b)}{t-a}$$

This is certainly true of the beta function $B(u,t)$. However, when we expand it to display the pole structure, we have

$$\begin{aligned}
 B(u,t) &= \sum_{N=0}^{\infty} \frac{g_N(u)}{t - \xi_N} && \text{(exhibiting the } t \text{ poles)} \\
 &= \sum_{N=0}^{\infty} \frac{g_N(t)}{u - \xi_N} && \text{(exhibiting the } u \text{ poles).}
 \end{aligned}$$

(The g_N and ξ_N are the same in both expansions.)

While either expansion has Bose symmetry as defined above, the symmetry is not achieved by the recipe. It is clear that, while

$$\sum_{N=0}^{\infty} \frac{g_N(u)}{t - \xi_N} + \frac{g_N(t)}{u - \xi_N}$$

is manifestly symmetric, it is not equal to the amplitude $B(u,t)$.

III. CROSS SECTION CALCULATIONS

For brevity, we restrict ourselves to total cross sections, σ_T , for $2 \rightarrow N$ processes. The rules for partial cross sections will be clear from this. In principle, to calculate σ_T , in the multi-Regge pole approximation, we must:

(a) Divide the phase space ϕ in $N!$ distinct, nonoverlapping regions ϕ_i , corresponding to the different orderings of final particles in rapidity.

(b) In each region ϕ_i , approximate M by $M_i^{(1)}$ or $M_i^{(2)}$ etc., integrate the approximate $|M_i|^2$ over ϕ_i to get the approximate contribution $\tilde{\sigma}_i$.

We then have, in the multi-Regge approximation, $\sigma_T \simeq \sum_i \tilde{\sigma}_i$.

(c) If identical particles are present, consider just the distinguishable orderings, i.e., $\sigma_T \simeq \sum_{\text{distinguishable}} \tilde{\sigma}_i$.

Such approximations to σ_T may, for example, be useful in bootstrap calculations that connect $2 \rightarrow 2$ absorptive parts to $2 \rightarrow 2$ total cross sections, via unitarity. In these calculations, it is hoped that the contributions to σ_T from the subregions of ϕ_i , where $M_i^{(1)}$ approximates M well, will dominate. The sharp fall off of residues with momentum transfers makes this plausible.

In practice, however, the conditions for "distinct, nonoverlapping regions" can only be achieved by restricting the Toller variables of each ordering by clumsy constraints. [In $2 \rightarrow 2$ equal mass scattering, the t channel $|M_t|^2$ is to be integrated over ϕ_t , the forward hemisphere, i.e., from $t = 0$ to $t = \frac{1}{2}(4m^2 - s)$; and the u channel $|M_u|^2$ over ϕ_u , from $u = 0$ to $u = \frac{1}{2}(4m^2 - s)$]. However, due to the rapid fall off of residues, in t , in the leading term $M_t^{(1)}$ of M_t , we can integrate $|M_t^{(1)}|^2$ over all t . The same goes for $|M_u^{(1)}|^2$. We then have symbolically (omitting flux factors),

$$\begin{aligned} \sigma_{\text{total}}^{el} &\simeq \tilde{\sigma}_t + \tilde{\sigma}_u = \int_{\phi_t} |M_t^{(1)}|^2 d\phi_t + \int_{\phi_u} |M_u^{(1)}|^2 d\phi_u \\ &\simeq \int_{\phi} |M_t^{(1)}|^2 d\phi + \int_{\phi} |M_u^{(1)}|^2 d\phi \end{aligned}$$

For $2 \rightarrow 2$ reactions, as $s \rightarrow \infty$, this will be an excellent approximation. If $N > 2$, largeness of s does not guarantee large

subenergies s_{ij} . We must then use severe cuts on the data (and hence the phase space ϕ) to ensure large s_{ij} 's. Then, the assumed t dependence of the residues will allow us to perform free integrals in the t 's without appreciable overcounting.

If we relax the constraints on the s_{ij} 's, we face the prospect of double counting, by doing free t integrals over phase space--we run through the same region of phase space several times, each time integrating a different approximation for $|M|^2$. When we do this, we must be cognizant of this error.

We urge the reader to read Ref. 3, where the author deals with the cross sections for the reactions $p\bar{p} \rightarrow m_{\pi}^{+} + m_{\pi}^{-} + k_{\pi}^{0}$. Apart from his remark on interference terms, we find that his paper adheres to the above rules.

IV. LITERATURE SAMPLING

We now discuss briefly, a sample (by no means exhaustive), of instances where concepts A and B, mentioned earlier, are encountered.

Ref. 4,5: Theoretical papers that assume M is a sum of pieces from all diagrams obtained by permuting final particle legs. It is argued in Ref. 4 that the interference terms are negligible, while Ref. 5 exploits their importance.

Ref. 6: A double-Regge analysis of $\pi^{+}p \rightarrow \pi^{+}\rho^{0}p$ at 13.1 GeV/c. Achieves a good fit by phase space overcounting, of the type discussed earlier (by admitting small s_{ij} regions). It is shown that a coherent addition of amplitudes obtained by permuting external legs is in disagreement with data.

Ref. 7: Fits data by coherent addition of permuted pieces in double-Regge analysis of $K^- n \rightarrow K^- \pi^- p$ at 5.5 GeV/c.

Ref. 8: A study of $pp \rightarrow pp + 2\pi^+ + 2\pi^-$ at 23 GeV/c. Gets M by

(a) Adding diagrams corresponding to different ordering of the protons in the chain (allowing them to go at the most one link from the ends).

(b) Symmetrizing by hand with respect to identical pions.

We find that a common trend in current phenomenology is to fit the Regge parameters of various diagrams in regions of phase space where they best approximate the amplitude, and then, to use their sum, coherent or incoherent, to get the cross sections in the rest of phase space. Since such fits involve multiple counting in the amplitude or phase space, they neither verify nor vilify the BCP multi-Regge hypothesis.

How then are we to test the above hypothesis? The heart of the multi-Regge hypothesis is that in certain special regions of phase space, the $2 \rightarrow N$ amplitude may be described by a few factorizable Regge poles. Factorizability implies that the trajectory and residue of a Regge pole, deduced in one situation, may be used in other situations where it occurs. We therefore suggest the following type of test of the hypothesis. For example, we could consider the region appropriate to the multi-Regge diagram of Fig. 5. The end couplings, $\beta_{\pi\pi P}(t_1)$ and $\beta_{ppP}(t_2)$ are known from pi-nucleon scattering. We can thus measure the middle coupling $\beta_{ppP}(t_1, t_2, \omega)$ (where P is the pomeron).

This residue, together with $\beta_{ddP}(t)$, measured from, say, πd scattering, must then fully determine M in the region corresponding to Fig. 6, if the multi-Regge hypothesis is correct.

It may be argued that the BCP hypothesis is not the, but a, multi-Regge hypothesis, and therefore, theorists and phenomenologists need not adhere to the rules it implies. Though we do not share such skepticism, we nevertheless wish to say this: Any multi-Regge theory, which is a natural generalization of $2 \rightarrow 2$ Regge theory, will likewise seek asymptotic expansions of M in certain special regions of phase space. Such expansions will be alternate and not additive, just as in $2 \rightarrow 2$ theory. Adding diagrams obtained by permuting external legs has a natural and legitimate place in perturbative field theory and in the reflexes of its expert practitioners, but not in any S-matrix calculation like $2 \rightarrow 2$ Regge theory or its generalization.

ACKNOWLEDGMENTS

I acknowledge with pleasure the constant, patient, and friendly guidance of Geoffrey Chew. Discussions with other members of the theory group at LBL, especially Ghassan Ghandour, were useful.

REFERENCES

- * This work was supported by the U. S. Atomic Energy Commission.
1. N. F. Bali, G. F. Chew, and A. Pignotti, Phys. Rev. 163, 1572 (1967).
 2. N. F. Bali, G. F. Chew, and A. Pignotti, Phys. Rev. Letters 19, 614 (1967).
 3. H. Goldberg, Phys. Rev. D6, 2542 (1972).
 4. G. F. Chew, M. L. Goldberger, and F. E. Low, Phys. Rev. Letters 22, 208 (1969).
 5. R. F. Amman and Prakash M. Shah, Syracuse University preprint SU-4205-265 (May 1972).
 6. J. W. Lamsa, J. A. Gaidos, R. B. Willmann, and C. Ezell, Phys. Rev. D1, 3091 (1970).
 7. Y. Cho, M. Derrick, D. Johnson, B. Musgrave, T. Wangler, and J. Wong, Phys. Rev. D3, 1561 (1971).
 8. D. E. Lyon Jr. and York-Peng Yao, Phys. Rev. D6, 3129 (1972).

FIGURE CAPTIONS

- Fig. 1. Toller diagram for $a + b \rightarrow 1 + 2 + \dots + N$.
- Fig. 2. Rapidity plot for multi-Regge region of Fig. 1.
- Fig. 3. Multi-Regge diagram depicting $M_1^{(1)}$ of Eq. (2).
- Fig. 4. Rapidity plot in multi-Regge region of ϕ_2 .
- Fig. 5. $\pi^+ p \rightarrow \pi^+ \rho^0 p$ in double Regge region.
- Fig. 6. Double Regge region of $\pi^+ d \rightarrow \pi^+ \rho^0 d$.

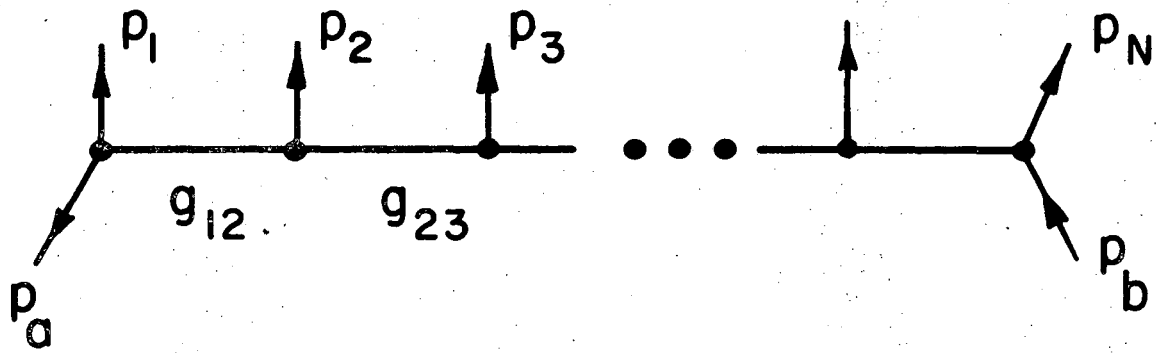

XBL732-2226

Fig. 1

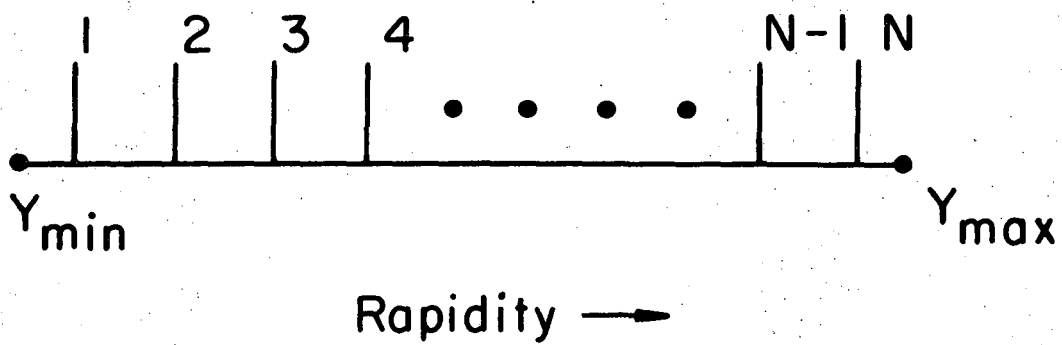

XBL732-2225

Fig. 2

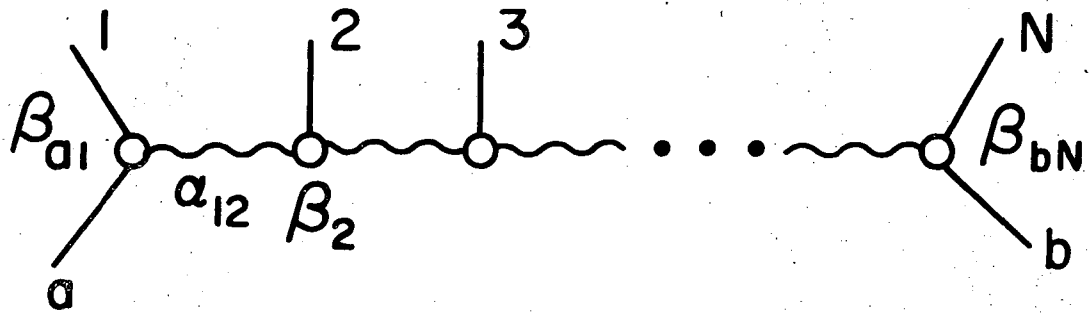

XBL732-2224

Fig. 3

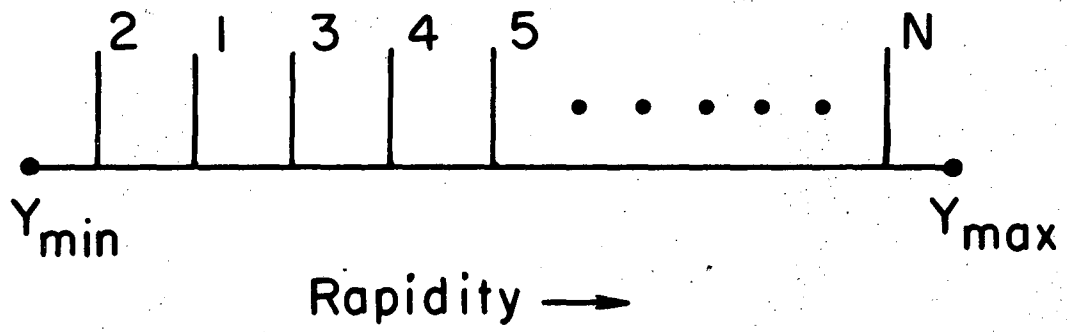

XBL732-2223

Fig. 4

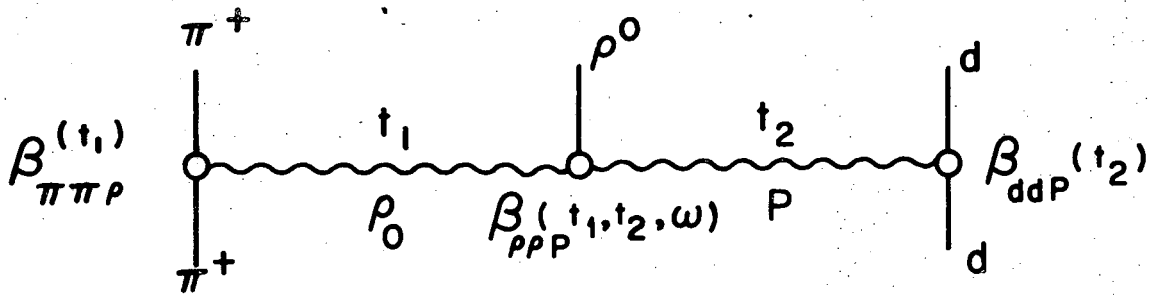
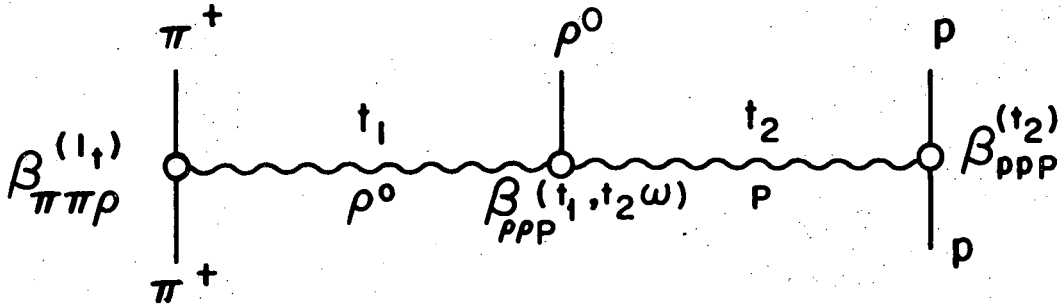

XBL732 - 2222

Figs. 5 and 6

CHAPTER II

CAN AND DOES THE POMERON OCCUR MORE THAN
ONCE IN A SINGLE PROCESS?

Nuclear Physics B63 (1974), 168

CAN AND DOES THE POMERON OCCUR MORE THAN ONCE IN A SINGLE PROCESS?*

R. Shankar

Lawrence Berkeley Laboratory
University of California
Berkeley, California 94720

October 12, 1973

ABSTRACT

A study of high energy diffractive amplitudes (the elastic amplitude being a special case), has revealed the following regularities at small momentum transfers: (a) They all tend to be almost purely imaginary, and (b) They all have the same energy dependence, leading to universal, constant (modulo logarithms) cross sections at high energies. In this paper, it is assumed that these regularities are produced by an underlying, common mechanism, which is defined as the pomeron. The question then addressed is whether the pomeron, so defined, can and does occur more than once in a single process.

It is demonstrated that various models for the pomeron (involving Regge poles, Regge cuts, geometric ideas like diffraction, etc.) lead to different answers to this question, none of them quantitative. By contrast, the introduction of the pion-pole dominance (PPD) hypothesis is shown to lead to a model-independent quantitative answer. Assuming just the above definition of the pomeron, the PPD hypothesis predicts certain processes that must be termed multi-pomeron by the advocates of all models, and provides estimates for their cross sections. The predictions of this hypothesis are compared with experiment.

* This work was supported by the U. S. Atomic Energy Commission.

It is shown that PPD leads to, and sets lower bounds for, inclusive triple-pomeron cross sections assuming no more than our general definition of the pomeron. It is pointed out that the repetition of the pomeron--guaranteed by PPD--may be used to set upper bounds on asymptotic total cross sections. The crucial property of the result --that total cross sections must eventually die away--is that it does not rely on any model-dependent property of the pomeron, such as factorization.

1. INTRODUCTION

Consider the collision of two particles a and b . We shall call this process a diffractive process if:

- (i) The final particles fall into two clusters A and B (in rapidity) centered around particles a and b respectively, and
- (ii) The quantum numbers of A and B are those of a and b respectively.

It should be emphasized that we use the word diffraction to refer only to these two properties of an event and do not imply any underlying optical model mechanism. Clearly elastic events fall under the class of diffractive events as defined above.

Imagine a rapidity plot of an event in which a and the cluster A occupy one end, say the left end, while b and B occupy the right end. If there is a large rapidity gap between the rightmost member of A and the leftmost member of B , we shall term it a high energy diffractive event. The following regularities have been detected empirically in the study of the amplitudes for such events:

(i) They all tend to be purely imaginary in the "forward" directions, that is, in regions of small momentum transfer t across the large rapidity gap.

(ii) They all have the same energy dependence in the small t region, leading to the universal, constant[†] cross section.

In the elastic case, these two properties, together with the optical theorem, imply that total cross sections at high energies are constant.

The universality of these two properties of diffractive amplitudes at high energies suggests a common underlying mechanism. It is assumed here that such a mechanism exists, and is called the pomeron. No specific models such as Regge poles, cuts or optical descriptions are assumed for the pomeron. It is simply defined by the context in which it occurs--as the controlling mechanism behind all high energy diffractive processes.

It should be pointed out that the word pomeron was originally coined by the Reggeists to stand for a factorizable Regge pole, which was their model for this mechanism. To avoid confusion, I shall use the word pomeron when referring to the mechanism in a model independent way and the word pomeron pole, when referring to the Reggeist's model for it.

The question before us is this: "Can the pomeron, as defined above, occur more than once in a single process?" In what follows, we shall try to answer this question restricting ourselves to a subset of diffractive events--the elastic ones. This is done only in the

[†] Unless otherwise stated, the word constant should be taken modulo logarithms.

interest of simplicity and brevity. In other words, whereas we shall consider from now on, only those situations in which the pomeron controls high energy elastic amplitudes, the conclusions we reach about its multiple occurrence are valid for the pomeron defined in the broad sense, as the mechanism behind all high energy diffractive events.

Consider the total cross section for two particles a and b . It typically has an energy dependence shown in fig. 1. There is a low energy resonance region characterized by sharp bumps which gives way to a smooth Regge region around S_{ab}^R . At higher energies, around S_{ab}^* , the Regge region turns into a flat region. The interesting fact is that while the two lower energy regions differ in their shapes as we change the particles a and b , the region above S_{ab}^* has a universal form. From the optical theorem, this implies that the corresponding elastic amplitudes must have a universal energy dependence in the forward direction. It is also found in the region above S_{ab}^* , that the elastic amplitudes are almost purely imaginary at small t . This then is the high energy diffractive region referred to earlier and according to our definition, the pomeron controls the elastic amplitude above the "pomeron threshold", S_{ab}^* . Can the pomeron, so defined, occur more than once in a single process?

There is no unanimity among the theorists in their answers, since different factions of theorists believe in different models and different models give different answers. This is not surprising, considering the diversity in the models. While the reggeists argue among themselves on whether to represent the pomeron by a factorizable Regge pole or by some nonfactorizable object like a cut in the J -plane; the advocates of the geometric models speak in terms of absorbing target

discs and projectiles diffracting around them. This state of affairs is elaborated in section 2.

Is there a model independent way of answering the question? Can one, assuming no more than a definition of the pomeron as the mechanism controlling all high energy elastic amplitudes, decide the question of its multiple occurrence? One can, if one steps outside current high energy ideas and invokes the old notion of pion pole dominance (PPD). It is shown in section 3 that armed with this hypothesis, one can define multi-pomeron processes, and estimate their cross sections, assuming no more than our general definition of the pomeron. In short, PPD provides a model-independent[†] and quantitative answer to the question of multi-pomeron processes. The predictions of this hypothesis are compared with experiment in section 4.

One can also use PPD to define and set lower bounds for inclusive triple-pomeron cross sections; as well as to set upper bounds on asymptotic, pomeron dominated cross sections; all in a model independent fashion. These ideas are discussed in section 5.

2. WHAT DO THE DIFFERENT MODELS OF THE POMERON SAY ABOUT THE QUESTION OF MULTI-POMERON PROCESSES?

I will consider just three models. They will suffice to show that the question of multi-pomeron processes, if analyzed within the language of the existing theories of the pomeron, becomes highly model dependent.

[†] The PPD hypothesis is, itself, a model. The words "model independent," as used in this paper, should be taken to mean "independent of any models for the pomeron."

A. The pomeron pole model

In the Regge language, a pomeron pole at[†] $J = 1$, with even signature, is the most economical way to explain the regularities mentioned earlier. The unit intercept provides the S^1 behavior, while the signature factor, $i - \cot\left(\frac{1}{2} \pi \alpha_P(t)\right)$, provides the correct phase at $t = 0$.

The elastic amplitude, for a typical $ab \rightarrow ab$ process, has the following form, when dominated by the pomeron pole:

$$M_{ab \rightarrow ab}(S, t) = \beta_{aaP}(t) (S)^{\alpha_P(t)} \beta_{bbP}(t) \quad (2.1)$$

This amplitude is represented pictorially in fig. 2. The factorized form allows us to abstract the pole, with a trajectory $\alpha_P(t)$, and speak of it in other reactions. Consider, for example, the process $ab \rightarrow ab\pi^+\pi^-$; in a part of phase space where the rapidity ordering of the particles is as shown in fig. 3.

If the subenergy $S_{a+} = (P_a^f + P_+)^2 > S_{a+}^*$, and the subenergy $S_{b-} = (P_b^f + P_-)^2 > S_{b-}^*$, Regge theory gives for the amplitude,

$$M_{ab \rightarrow ab\pi^+\pi^-} = \beta_{aaP}(t_1) (S_{a+})^{\alpha_P(t_1)} \gamma_{\pi\pi PP}(S_{\pi\pi}^c, t, t_1, t_2) \\ \times (S_{b-})^{\alpha_P(t_2)} \beta_{bbP}(t_2) \quad , \quad (2.2)$$

as depicted in fig. 4.

Let us summarize what Regge theory tells us, granted that the pomeron is indeed a factorizable pole.

[†] When I speak of a moving singularity, such as the pomeron pole, $\alpha_P(t)$, being at $J = 1$, I mean $\alpha_P(0) = 1$.

(a) It clearly defines a double-pomeron process as one in which the pomeron pole occurs twice in the amplitude, as in eq. (2.2) or fig. 4. The pomeron pole encountered here is the one from the elastic reaction that originally defined it [eq. (2.1) or fig. 2].

(b) While Regge theory says that the external couplings, $\beta(t)$, are the same ones encountered in the elastic case, all it says of γ , the central coupling, is that γ is independent of a and b . It gives neither the scale of γ , nor the dependence on the variables, $S_{\pi\pi}^c$, t , t_1 , and t_2 .

(c) Regge theory does, however, give the dependence of the amplitude on the subenergies, S_{a+} and S_{b-} . This dependence may be used by the experimentalist to identify double-pomeron processes.

In short, granted a pomeron pole, Regge theory admits and defines a double-pomeron process, but leaves it to experiment to set the scale or rate. This conclusion is true for a general multi-pomeron process.

B. The Regge cut model of the pomeron

Theoretical analysis following the introduction of the pomeron pole has indicated that such a simple description of the pomeron leads to inconsistencies. For one thing, if there is a pomeron pole at $J = 1$, as suggested by the observed constancy of total cross sections, the multi-pomeron branch points accumulate at $J = 1$ [1]. For another, starting with a factorizable pomeron pole at $J = 1$, one can get into situations where some partial cross sections exceed the total, unless the triple-pomeron coupling, $g_{ppp}(t)$, vanishes at $t = 0$ [2,12]. At present, when neither $g_{ppp}(0)$ nor the importance of multi-pomeron branch points is known, the J -plane singularity associated with the pomeron is obscure. What does Regge theory say about the possibility

of multi-pomeron processes, if the pomeron is represented by a non-factorizable J-plane singularity, such as a cut? Strictly speaking, it is incorrect to speak of the recurrence (single or multiple), of a nonfactorizable singularity. The reason is that such singularities, unlike factorizable poles, do not have an identity independent of the specific reaction they occur in. For example, if the leading J-plane singularity in the high-energy elastic ab amplitude were a cut, we could not dissociate the cut from the particles a and b . The only time we can be sure that this same cut occurs in a different process, is when the amplitude involves explicitly the high energy $a-b$ amplitude as a factor.

There is, however, a slightly nonrigorous way of speaking of a nonfactorizable singularity without associating it with a specific reaction, and that is by its location in the J-plane or, alternatively, by the energy dependence it produces. Motivated by the universal high energy dependence of all total cross sections, one may assume that their J-planes are universal, in that their leading singularities will have the same location. If, therefore, one defines the salient feature of the pomeron to be this energy dependence, one may define a multi-pomeron process as one in which this dependence is repeated. For example, in the reaction $ab \rightarrow ab\pi^+\pi^-$ discussed earlier (fig. 3), with $S_{a+} > S_{a+}^*$ and $S_{b-} > S_{b-}^*$, if one finds the same dependence of the amplitude on these variables as in the elastic $a-\pi$ and $b-\pi$ reactions, respectively, one may refer to this reaction as a double-pomeron process. While such a definition tells the experimentalist what to look for, Regge-cut theory does not provide an explicit form such as eq. (2.2), for the amplitude of this process.

C. The geometric or diffraction model [3]

In this model, the collision of particles a and b is viewed in geometric terms. The projectile a sees the target b as a disc. At high energies, the disc becomes highly absorbing, due to the preponderance of inelastic channels. In a naive sense, the constancy of total cross sections may be understood in terms of a constant radius, R, of the disc. The phase is largely controlled by the absorptivity. To see this connection, consider the following rather artificial, but illustrative example. For a collision of spinless particles, the partial wave series for the amplitude is given by

$$M(s, \theta) = \sum_{\ell=0}^{\infty} (2\ell + 1) \frac{\left(\eta_{\ell} e^{2i\delta_{\ell}} - 1 \right)}{2ik} P_{\ell}(\cos \theta) .$$

Let us resort to the following simple minded description of the scattering:

(a) The target disc absorbs ($\eta_{\ell} = 0$) all partial waves that impinge on it, i.e., till $\ell = \ell_{\max} = kR$; where k is the momentum of the projectile in the target rest frame,

(b) All higher partial waves go unaffected, ($\eta_{\ell} = 1, \delta_{\ell} = 0$).

The phase of the amplitude is then clearly imaginary. In practice, of course, the description is more complicated [4].

It is curious that the geometric diffraction model, which, despite its vastly different logic, concurs with the Regge pole model regarding many of the features of the pomeron in high energy elastic amplitudes, takes a very different stand on the question of multi-pomeron processes. Where are the two absorbing discs in the reaction $ab \rightarrow ab\pi^+\pi^-$ that might justify calling this reaction a double-

pomeron process? Advocates of the geometric model see no reason for-- indeed no meaning for--the repetition of the pomeron.

Having discussed at some length the various models of the pomeron and the varying answers they give to the question of multi-pomeron processes, we are now ready to embark on a study of the PPD hypothesis and the model-independent answer it provides.

3. THE PION POLE DOMINANCE HYPOTHESIS

In this section, the question of multi-pomeron processes will be discussed, assuming no more than our general definition of the pomeron. For simplicity, let us consider a specific reaction, $\pi^- p \rightarrow \pi^- p \pi^+ \pi^-$. Let us go to the part of phase space shown in the rapidity plot of fig. 5. It is a general property of the amplitude that, when $t = (P_a^f + P_+ - P_a^i)^2 = \mu^2$, it is given by a pion pole, with a factorizable residue:

$$M_{\pi^- p \rightarrow \pi^- p \pi^+ \pi^-} \xrightarrow[t \rightarrow \mu^2]{} \frac{A_{\pi \pi}^{+ -}(V_L) A_{\pi p}^{-}(V_R)}{t - \mu^2}, \quad (3.1)$$

as pictorially represented in fig. 6.

In eq. (3.1), the factor $A_{\pi \pi}^{+ -}(V_L)$ is the elastic, $\pi^+ \pi^-$ scattering amplitude, as a function of the variables, V_L , associated with the left blob. A similar definition holds for $A_{\pi p}^{-}(V_R)$ at the right blob.

The crucial point is that if the two subenergies, S_{a+} and S_{a-} , exceed the pomeron thresholds, S_{a+}^* and S_{b-}^* , the pomeron will occur in each blob by definition, and produce the characteristic subenergy dependence and phase in the two elastic amplitudes.

This process must be termed double-pomeron by any standards, since the precise situations that contain the pomeron by definition, occur twice. The form of the amplitude in eq. (3.1) allows us another way of seeing this. Let us use, in eq. (3.1), the principle of CPT invariance to replace the amplitude $A_{\pi^- p} (V_R)$ by the amplitude for the CPT-transformed process, $A_{\pi^+ p} (V_R)$. We may now see the amplitude M as describing a two stage process--the reaction $\pi^+ p \rightarrow \pi^+ p$ followed by the reaction $\pi^+ \pi^- \rightarrow \pi^+ \pi^-$ --in which the π^+ going into the second collision is the one that came out of the first. At $t = \mu^2$, this π^+ is a real pion, and the two collisions are real collisions and can be separated in space-time. Clearly these two elastic events are independent, and the pomeron, whatever be the model for it, will occur in each, if the subenergies are above the pomeron thresholds. We thus see that there are really two discs in this process--one in each elastic collision. By the same token, there are two pomeron poles or two Regge cuts or two of whatever-you-think-the-pomeron-is. There is, however, a catch to this argument. The point $t = \mu^2$ where these considerations apply, is outside the physical region which is confined to negative t . The redeeming factor is the smallness of the quantity μ^2 ($\simeq 0.02 \text{ GeV}^2$) which prompts the following hypothesis of PPD: The amplitude in the physical region is given by the factorizable function [eq. (3.1)] defined at the pole, multiplied by a t -dependent form factor, $f(t)$. Although the entire physical region is not close to the pion pole, the region where the amplitude is significant is close to it, since the (amplitude)² contains the factors $(t - \mu^2)^{-2}$ and $f(t)$, both of which are rapidly falling functions

of $t' = -t$ †. Support for the PPD hypothesis and the specific choice of the form factor appropriate to this problem are discussed at length in the Appendix. For the present let us accept a simple-minded form factor given by $f(t') = 1$ for $0 < t' < T$, and zero beyond. The Appendix will justify this choice and provide the value for T .

Starting with the matrix element M of eq. (3.1), we can integrate $|M|^2$ over t' up to T , over the blob subenergies from the pomeron thresholds up to the kinematically allowed maxima, to get $\sigma_{+-}^{DP}(S,T)$, the double-pomeron cross section for this ordering (fig. 5) of the central pions. The following is the result:

$$\begin{aligned} \sigma_{+-}^{DP}(S,T) &= \frac{2.5}{16\pi^3 S^2} \int_{S_{a+}}^* \frac{ST/(S_{b-}^* - m^2)}{S_{a+}} dS_{a+} S_{a+} \sigma_{\pi\pi}^{e\ell}(S_{a+}) \\ &\times \int_{S_{b-}}^* [(ST/S_{a+}) + m^2] dS_{b-} (S_{b-} - m^2) \sigma_{\pi p}^{e\ell}(S_{b-}) \\ &\times \int_{t'_{\min}=[S_{a+}(S_{b-}-m^2)/S]}^T \frac{dt'}{t'^2} \text{mb} \quad (3.2) \end{aligned}$$

This formula is from ref. [5], adapted to a situation where the energies, S , S_{a+} , and S_{b-} are large and the pion mass is ignored. (The last approximation leads to little error, due to the t'_{\min} limit.) The

† We shall be using both variables t' and t in the future.

kinematical upper limit on the subenergies guarantees that t'_{\min} never exceeds T . The proton mass is m .

To estimate $\sigma_{+-}^{DP}(S,T)$ from eq. (3.2), one can feed in the empirical $\pi\text{-}\pi$ and $\pi\text{-}p$ cross sections and perform a numerical integration. Since these calculations are anyway quite approximate, let us resort to a simplification that gives a quick estimate. Let us replace the elastic cross sections, which vary slightly with the subenergies, by constants $\sigma^{el}(\infty)$, that represent their average behavior in the region between the pomeron thresholds and the kinematically allowed maxima. With this simplification the integral can be easily performed to give

$$\sigma_{+-}^{DP}(S,T) = \frac{T \times 2.5 \times \sigma_{\pi\pi}^{el}(\infty) \times \sigma_{\pi p}^{el}(\infty)}{16\pi^3} \left[\frac{1}{2} \log Z - \frac{3}{4} + \frac{1}{Z} - \frac{1}{4Z^2} \right] \text{ mb} \quad (3.3)$$

where

$$Z = \frac{ST}{S_{a+}^* (S_{b-}^* - m^2)}$$

Choosing $\sigma_{\pi\pi}^{el}(\infty) = 3 \text{ mb}$, $\sigma_{\pi p}^{el}(\infty) = 5 \text{ mb}$, $S_{a+}^* = 2 \text{ GeV}^2$,

$S_{b-}^* = 4 \text{ GeV}^2$, $T = 0.25 \text{ GeV}^2$, leads to

$$\sigma_{+-}^{DP} = 13.4 \text{ } \mu\text{b} \quad \text{at } S = 386 \text{ GeV}^2.$$

The value of S is chosen to facilitate comparison with recent experiments performed at NAL at 205 GeV/c. While the choice of T is discussed in the Appendix, it must be mentioned here that it could be lower in principle, but not likely to be lower than 0.125 GeV^2 .

The pomeron thresholds are chosen to eliminate all prominent resonances. Some contamination from lower trajectories is inevitable. This question is taken up later.

A similar calculation for σ_{-+}^{DP} , the cross section for events with the other ordering of the two central pions in rapidity, yields a formula similar to eq. (3.1), with

$$Z = \frac{ST}{S_{a-}^* (S_{b+}^* - m^2)}$$

In this formula, S_{a-}^* is the pomeron threshold for a $\pi^-\pi^-$ system. Due to the lack of any structure in the cross section in this channel, it is hard to select a value for S_{a-}^* . The following alternative criterion for pomeron dominance is suggested and is to be observed both in the calculation of the theoretical estimate and in the experimental selection of double-pomeron events: The $\pi^-\pi^-$ subsystem is pomeron dominated when the rapidity gap Δy , between the two pions is two units or more. For a phenomenological connection between $\Delta y \geq 2$ and pomeron dominance, see ref. [7]. The theoretical estimate, which deals with subenergies rather than rapidities, requires us to convert a minimum rapidity gap $\Delta y = 2$ into a minimum subenergy S_{a-}^* . If the two pions have transverse momenta \vec{P}_a and \vec{P}_- , and have $\Delta y = 2$ their subenergy is

$$S_{a-}^*(\vec{P}_a, \vec{P}_-) = 2\mu^2 + \left(|\vec{P}_a|^2 + \mu^2 \right)^{\frac{1}{2}} \left(|\vec{P}_b|^2 + \mu^2 \right)^{\frac{1}{2}} \cosh 2$$

$$- 2\vec{P}_a \cdot \vec{P}_b$$

Assuming that on the average,

$$(i) \quad |\vec{P}_a| = |\vec{P}_b| \simeq 0.3 \text{ GeV}/c$$

(ii) $\vec{P}_a \cdot \vec{P}_b \simeq 0$ we get $S_{a-}^* = 0.8 \text{ GeV}^2$. With the other parameters same as before, we get

$$\sigma_{-+}^{DP} = 20.4 \text{ } \mu\text{b} \quad \text{at } S = 386 \text{ GeV}^2.$$

The total double-pomeron cross section is given by

$$\sigma^{DP}(S = 386 \text{ GeV}^2) = \sigma_{+-}^{DP} + \sigma_{-+}^{DP} = 33.8 \text{ } \mu\text{B}.$$

The same set of parameters yields for the reaction $pp \rightarrow pp\pi^+\pi^-$ a total double-pomeron cross section of $31.3 \text{ } \mu\text{b}$ at $205 \text{ GeV}/c$ ($S = 387 \text{ GeV}^2$).

Comparison with experiment: Recently two groups have measured double pomeron cross sections as defined in this paper. The reaction $\pi^- p \rightarrow \pi^- p\pi^+\pi^-$ at $205 \text{ GeV}/c$ was studied by an NAL-LBL-UC Berkeley collaboration [7], while the reaction $pp \rightarrow pp\pi^+\pi^-$ at $205 \text{ GeV}/c$ was studied by the Argonne group [8]. Omitting details of the experiments since they may be found in the references quoted, I present below the comparison between the theoretical estimates of the cross sections and the empirically measured values.

<u>Reaction</u>	<u>P_{lab}</u>	<u>σ (experiment)</u>	<u>σ (theory)</u>
$\pi^- p \rightarrow \pi^- p\pi^+\pi^-$	205 GeV/c	$30 \pm 10 \text{ } \mu\text{b}$	33.8 μb
$pp \rightarrow pp\pi^+\pi^-$	205 GeV/c	$44 \pm 15 \text{ } \mu\text{b}$	31.3 μb

We find that the measured cross sections are compatible with the theoretical estimates. As a result of the rather low values of the S^* used here, there is surely some contamination from lower trajectories. Raising these minimum subenergies (in the theoretical estimate and in the experimental selection of events) will lead to "purer" double-pomeron cross sections. At the present energies and statistics, such a move will lead to prohibitively low cross sections. In future experiments with higher energies or statistics or both, this will be a desirable as well as feasible modification.

In addition to providing an estimate of the integrated cross section, the PPD hypothesis also makes two predictions on differential cross sections. These could not be meaningfully tested with the present statistics.

(i) The t' distribution: Consider the general reaction $ab \rightarrow ab\pi^+\pi^-$. By integrating eq. (3.2) over the subenergies we obtain

$$\frac{d\sigma}{dt'} = \frac{2.5 \times \sigma_{ai}^{el}(\infty) \sigma_{bj}^{el}(\infty)}{16\pi^3} \times f(Z) \left[\frac{1}{2} \log Z - \frac{1}{4} + \frac{1}{4Z^2} \right] \text{ mb/GeV}^2 .$$

(3.3')

This formula refers to a specific rapidity ordering of the central pions--pion i nearest to a and pion j is nearest to b . In the formula, $Z = t'/t_0$, where $t_0 = (S_{ai}^* - m_a^2)(S_{bj}^* - m_b^2)/S$ and $f(Z)$ is the form factor. As mentioned in the Appendix, [eq. (A.3)], the form factor appropriate to these calculations is $f(t') = e^{-4t'}$. In eqns. (3.2 and 3.3), where the aim was to integrate over t' , this form was replaced for convenience by $f(t') = 1$ for $0 < t' < T = 1/4$ and zero beyond. For the differential cross section of course, we

must use the exponential form. Typically $d\sigma/dt'$ rises from t_0 up to $10 t_0$ and falls monotonically thereafter. For example, in the process depicted in fig. 6, $t_0 = 0.016 \text{ GeV}^2$ and the peak is around $t' = 0.16 \text{ GeV}^2$. Unlike quasi-two-body reactions, which typically fall monotonically in t' , these cross sections are predicted to first rise and then fall. They owe this property to the fact that here the two blob masses do not have to lie in some resonance band but are allowed to vary. As t' increase from t_0 , the allowed range of mass variation increases, while the factors $f(t')$ and $(t' + \mu^2)^2$ decrease.

(ii) Distribution in $S_{\pi\pi}^c$: According to the Steinman relations [9], the amplitude cannot have simultaneous poles in t and in $S_{\pi\pi}^c$, the $(\text{mass})^2$ of the two central pions. Thus the residue, R , of the pole at $t = \mu^2$, will not have pole in $S_{\pi\pi}^c$, say due to the f meson.

According to the PPD hypothesis, there exists a (physical) region of small t' ($= -t$) in which the amplitude is essentially what is found at the pole (except for a t -dependent form factor which introduces no singularity in $S_{\pi\pi}^c$). In this region of "small" t' , if one divides the events into bins (of width 0.05 GeV^2 for example) and plots within each bin the distribution of events versus $S_{\pi\pi}^c$, one should see none of the resonances of the dipion system. Conversely, the t' above which these resonances show up would mark the breakdown of the PPD hypothesis, telling us what "small" t' means. Such a test, which can be done in quasi-two-body reactions as well, will tell us in one stroke the validity of the Steinman relations as stated above, and the range of validity of the PPD hypothesis.

We thus infer from the Steinman relations that PPD is challenged not only by the neglected singularities in t but also by the

singularities in $S_{\pi\pi}^c$. At a fixed value of $S_{\pi\pi}^c$, if we increase $-t$, the neglected singularities in t compete with the pion pole. At some fixed t , if we vary $S_{\pi\pi}^c$, a pole in $S_{\pi\pi}^c$ can dominate the amplitude if we get sufficiently close to it. Should this happen, the pion pole will be absent in the amplitude according to the Steinman relations. In our example, if we focus on the f -meson pole in $S_{\pi\pi}^c$, the closest we can get to it, by varying $S_{\pi\pi}^c$ along the real axis, is given by the imaginary part of the pole position, which is equal to the product of its mass and width, with a value of about 0.2 GeV^2 . At this point of closest approach, we can say roughly that PPD will be challenged by the f -meson pole for $-t$ around 0.2 GeV^2 , assuming equal residues for the two poles. Thus the breakdown of the PPD hypothesis can be brought about by either the neglected singularities in t or the neglected singularities in $S_{\pi\pi}^c$. The former could be detected by a study of density matrix elements in quasi-two-body reactions and the latter by a search for resonances in $S_{\pi\pi}^c$.

It is interesting to study two earlier attempts at detecting double-pomeron processes in the light of the PPD hypothesis. Leipes, Zweig, and Robertson (LZR) [10] studied $\pi^- p \rightarrow \pi^- p \pi^+ \pi^-$ at 25 GeV/c while Rushbrooke and Webber (RW) [11] studied $pp \rightarrow pp \pi^+ \pi^-$ at 6-25 GeV/c. Both assumed the double-Regge pole form of the amplitude, eq. (2.2), for the double-pomeron process and found that such an amplitude had negligible weight in their fit to the double-Regge region. This means either that the central coupling γ is very small, or that the pomeron is not a factorizable pole and the amplitude doesn't contain a factored component like eq. (2.2).

Does the failure of these two analyses to detect double-pomeron processes conflict with the estimates of PPD? No! The reason is that the PPD formula gives a miniscule $4 \mu\text{b}$ for the experiment of LZR ($S = 50 \text{ GeV}^2$) and a similar result for that of RW. Instead of using the formula we can see the smallness of the PPD estimate in the following way. For the double-pomeron process to occur via PPD, we require not only that the two end blobs be massive, but that the central link be kinematically allowed to have small t 's. In the $\pi^- p \rightarrow \pi^- p \pi^+ \pi^-$ reaction that we just discussed, we saw that

$$t'_{\min} = \frac{S_{a+} (S_{b-} - m^2)}{S}$$

Assuming that the only sizeable cross sections are for those reactions in which a t' , of say 0.1 GeV^2 , is accessible, we need an S given by

$$\frac{S_{a+}^* (S_{b-}^* - m^2)}{S} < \frac{1}{10},$$

using the smallest values of S_{a+} and S_{b-} compatible with the double-pomeron region. Using the S^* values quoted earlier, this condition requires $S > 45 \text{ GeV}^2$, a requirement barely met in the LZR experiment. A similar consideration applies to the RW experiment.

In the language of these two analyses, involving pomeron poles, the PPD hypothesis sets a lower bound on the central coupling, $\gamma(S_{\pi\pi}^C, t, t_1, t_2)$, by focussing on the pion pole at $t = \mu^2$, with a residue known from elastic experiments (fig. 7).

In their analysis, LZR conclude that the absence of an f resonance in $S_{\pi\pi}^C$ further corroborates the absence of the double-

pomeron events. This conclusion is true only as long as γ is controlled by a pole in $s_{\pi\pi}^C$ (fig. 8). If such a pole were present with a substantial residue, it would lead to double-pomeron events at lower energies, since t' need not be small. Their analysis essentially indicates the absence of such a pole.

In the PPD induced, double-pomeron processes, the situation is just the opposite--namely, the absence of resonant structure in $s_{\pi\pi}^C$ accompanies the controlling mechanism, the pion pole.

5. FURTHER APPLICATIONS OF PPD

A. Triple-pomeron cross sections

The PPD hypothesis, together with the definition of the pomeron, may be used to define and set lower bounds for inclusive triple-pomeron cross sections. Consider, for example, the reaction $p(P_a) + p(P_b) \rightarrow p(P_c) + X$, the parentheses containing the momenta of the protons. Let us restrict ourselves to events in which P_c is very close to P_a . Let M_x be the mass of the undetected particles, X . We are interested in the inclusive cross section,

$$\frac{d\sigma}{dt d(M_x^2/s)}, \quad \text{where } t = (P_c - P_a)^2 \quad \text{and} \quad M_x^2 = (P_a + P_b - P_c)^2.$$

Consider all exclusive events in this region with the property that of all the particles in the cluster X , the one nearest to the proton, in rapidity, is a pion of momentum P_d (fig. 9). The contribution of these exclusive events to the inclusive cross section involves, among other integrations, one over $u = (P_d + P_c - P_a)^2$, from zero to the kinematical limit in the negative u region. At $u = \mu^2$, the amplitude factorizes:

$$M \xrightarrow[u \rightarrow \mu^2]{} \frac{A_{\pi p}(S_1, t) A_{\pi p \rightarrow x'}(V_{x'})}{u - \mu^2} \quad (5.1)$$

Using PPD, we may integrate this $|M|^2$, over a region of small negative u , up to $-U$. The integral over $V_{x'}$ is done using the optical theorem. These operations are best represented pictorially (fig. 10). The result is $d\sigma^\pi/dt d(M_x^2/S)$, the contribution to $d\sigma/dt(d M_x^2/S)$ from the pion pole in u .

If the three blobs of fig. 10 have subenergies above the pomeron thresholds, the pomeron will occur in each of them doing its job. This then is a triple-pomeron process in a model-independent sense. One can estimate the magnitude of this pion-pole contribution using πp elastic and total cross section data.

It is only when one speaks of a triple-pomeron pole coupling, $g_{PPP}(t)$; that one needs to put pomeron poles in the blobs. Such a calculation has been done by Sorensen [6] who estimated $g_{PPP}(t)$. His paper also contains the phase space details omitted here.

B. Asymptotic bounds on total cross sections

Theorists have repeatedly been driven [2,12] to the conclusion that if the pomeron were to be a factorizable Regge pole, it couldn't be at $J = 1$ (i.e., all total cross sections must eventually die away), unless the triple-pomeron coupling $g_{PPP}(t)$ vanished at $t = 0$. This result is arrived at by repeating the pomeron in certain judiciously chosen circumstances, either exclusively or inclusively. To ensure its repetition these authors assumed its factorization, and their results seem to rely on this assumption.

On the other hand, we have seen that using PPD, the pomeron may be kept inside blobs and repeated using just the factorizability

of the pion pole. It follows that the ailments accompanying an asymptotically constant,[†] pomeron-dominated cross section will ensue, forcing total cross sections to eventually die away. The crucial feature of the result is that it is independent of the J-plane singularity associated with the pomeron.

To get the bounds, one needs to find appropriate situations with repeated pomerons, to avoid pitfalls of multiple counting, and to do the phase space. These details will be discussed and the bounds derived in a subsequent paper.

6. CONCLUSIONS

The universal energy dependence and phase of high-energy diffractive amplitudes (of which the elastic is a special case), suggests an underlying mechanism. In this paper, such a mechanism was assumed to exist, and defined to be the pomeron. The question taken up was "Can and does the pomeron, so defined, occur more than once in a single process?" An analysis of various models of the pomeron indicated that different models gave different results, none of them quantitative. The introduction of the PPD hypothesis provided a model independent, quantitative answer whose utility was demonstrated in the specific reaction, $\pi^- p \rightarrow \pi^- p \pi^+ \pi^-$. At the pion pole (fig. 6), the production amplitude factored into a product of two elastic amplitudes, $A_{\pi^+ \pi^-}$ and $A_{\pi^- p}$. Since these elastic amplitudes contain the pomeron by definition at high energies; the situation at the pion pole is a double-pomeron process in a model independent sense. In

[†] In this context the word "constant" has the usual meaning and not modulo logs.

terms of the space-time description outlined earlier, possible at $t = \mu^2$, one may see the process as one in which a real π^+ of mass μ , first suffers an elastic collision with a \bar{p} , and then proceeds to collide elastically with the π^- . Since there are two collisions, there are two pomerons, granted large enough subenergies. The PPD hypothesis allows a continuation of these ideas, valid at $t = \mu^2$, to the nearby physical region.

A comparison with two recent experiments, $\pi^- p \rightarrow \pi^- p \pi^+ \pi^-$ and $pp \rightarrow pp \pi^+ \pi^-$, both at 205 GeV/c, shows that the observed cross sections are compatible with the theoretical estimates. Further tests of the PPD hypothesis, which must await experiments with greater energies, statistics or both, are suggested. A study of two earlier attempts at detecting double-pomeron cross sections shows that their negative results are compatible with the PPD model.

It was shown that PPD, together with no more than our general definition of the pomeron, leads to lower bounds on triple-pomeron processes. It was pointed out that using PPD to repeat the pomeron, one could derive upper bounds on the asymptotic pomeron dominated cross sections, without making model-dependent assumptions about the pomeron, such as its factorizability. If the present degree of validity of PPD persists asymptotically, the result that total cross sections must eventually die away seems inescapable, no matter what the nature of the singularity associated with the pomeron.

The philosophy throughout this paper has been to use the pion to analyze the pomeron, rather than to use the pomeron to analyze itself. The pomeron, whose nature is enigmatic, is kept within blobs, and only the pion, whose properties (particularly its factorizability) are certain, is explicitly shown. The catch is that the

factorizability of the amplitude is guaranteed only at the pion pole and not in the physical region. One has to assume, via PPD, that this crucial property is not lost in the transit from the pole, to the physical region, 0.02 GeV^2 away. This seems plausible (due to the smallness of μ^2), has worked in the past, works at $S \simeq 400 \text{ GeV}^2$, but can never be proved.

ACKNOWLEDGMENTS

It is my pleasure to thank Geoffrey Chew for suggesting this investigation and following it up with numerous invaluable and exciting discussions. It is likewise a pleasure to thank the member of the NAL-LBL-Berkeley group, in particular Denyse Chew, and the members of the Argonne group, particularly Philip Schreiner, for performing analyses of their data, which provide the tests for the ideas put forth in this paper. My thanks also go to my colleagues at LBL for their incisive and instructive criticism when these ideas were presented before them.

APPENDIX

The arguments supporting the existence of double-pomeron cross sections rested on two assumptions:

(1) At the pion pole the amplitude factorizes--the residue R is a product of two elastic amplitudes, each of which will contain the pomeron if the subenergies are large enough.

(2) This behavior will persist in the small t' region. The only difference from the situation at the pole will be the inclusion of a form factor, $f(t)$, (the PPD hypothesis).

The first assumption will not be discussed here since it is a widely accepted and basic property of the amplitude. The second notion involves a guess as to how the amplitude behaves in the physical region of small t' , knowing its behavior at the pole. These are essentially two schools of thought that make two different guesses.

A. The S-matrix approach. Here the problem is viewed as that of guessing the behavior of an analytic function near a pole with a known residue. There is no systematic way to do this. The PPD hypothesis is a guess prompted by the notion that since the physical region is close to the pole, the amplitude should not vary too much in going from the pole to the physical region. Only experiment can decide the validity of such a guess and if it proves a valid guess, to decide its range (in t') of validity. We shall return to this question later.

B. The absorption model [13-15]. This model has proved very useful in the study of quasi-two-body reactions. Here one essentially identifies the amplitude at $t = \mu^2$ with a single Feynman diagram (the "pion pole" diagram), since at this point it dominates over the other diagrams (fig. 11a). Away from $t = \mu^2$ the neglected diagrams

have to be considered. The crux of the absorption model is that the effect of the neglected diagrams may be incorporated by the inclusion of initial and final state interactions (fig. 11b) [13,15]. Once again only experiment can decide the validity of this guess.

Over the last few years, numerous quasi-two-body reactions have been studied to test and compare the two guesses or models. Both models are required to explain the empirical fact that often the fall in t of the differential cross section is sharper than what the pion pole factor $(t - \mu^2)^{-2}$ would indicate. In the S-matrix approach, this is achieved by the incorporation of form factor [16,17]. While these form factors, suitable for describing final states containing resonances or stable particles of definite spin, have kinematical and dynamical notions behind them, they are not free of arbitrary parameters that must be deduced from experiment [18].

In the absorption model, the sharp collimation in t is a result of the initial and final state interactions. To the extent that the initial state interaction is given by the elastic scattering data (see fig. 11b), it is free of parameters. The final state interactions, since they are not subject to direct measurement, must be handled either via additional assumptions or additional parameters that may be empirically determined [13].

In short, both models can usually describe any differential cross section $d\sigma/dt'$ with the help of judiciously chosen parameters. By contrast, the study of the density matrix elements, ρ_{ij} , of the decaying final state resonances, such as the ρ^0 in the reaction $\pi^- p \rightarrow \rho^0 \Delta^0$, can distinguish the two models. The PPD model, with a factorizable amplitude, predicts that in the decay of the ρ -meson, all

the density matrix elements will vanish for all values of t' in the Gottfried-Jackson frame, with the exception of ρ_{00} , which will be unity [13]. The absorption model, with a nonfactorizable amplitude can admit a nonzero value for all ρ_{ij} . However, for small t' the predictions of this model approach the values given by the PPD model.

The empirical situation is as follows. One finds that for small t' (usually up to $0.15-0.2 \text{ GeV}^2$) ρ_{00} is between 0.8 and 1, while the others are very small, usually around 0.05 [19-21]. For larger values of t' , the results differ substantially from the PPD predictions. The absorption model, although parameter dependent, is able to accommodate and describe these matrix elements in this region.

We have seen that in our problem, the bulk of the t' integration comes from small t' (around 0.15 GeV^2 for the specific process depicted in fig. 6). Based on the study of the density matrix elements in this region, we may say that in this range of t' , the PPD and absorption models are indistinguishable and in agreement with experiment. After all both of them have to agree at the pole, and if the process is a smooth one the merger could be expected around small t' .

Further evidence for factorization at small t' comes from a study of $\pi^- p \rightarrow \rho^0 \pi^- p$ at 6 and 8 GeV/c, described in ref. [22]. Here the PPD model is assumed for $t' - t'_{\min} < 0.3 \text{ GeV}^2$ and the off-shell π - p cross section (lower vertex in fig. 12a) $d\sigma^{\text{off}}/d\Omega$, is extracted and found to have the same angular dependence as its on-shell counterpart, except for an overall scale. It is also found that if the lower vertex is allowed to be inelastic (lower vertex, fig. 12b), and the off-shell cross section for the process $\pi^- p \rightarrow \pi^- \pi^0 p$ is derived, then the ratio $\sigma^{\text{off}}(\pi^- p \rightarrow \pi^- \pi^0 p) / \sigma^{\text{off}}(\pi^- p \rightarrow \pi^- p)$ agrees with the on-shell ratio.

Another factor that controls the success of PPD, in addition to the smallness of t' , is the absence of competing mechanisms. In the process $\pi^- p \rightarrow \pi^- p \pi^+ \pi^-$ it is clear that the link carrying the momentum transfer t must have $I^G = 1^-$. The same conclusion may be reached for the process $pp \rightarrow pp \pi^+ \pi^-$ if one makes the additional assumption that the two protons at the two ends do not send any quantum numbers to the central pions (which is tantamount to assuming a factorizable pomeron controlling the two end blobs). This means that the π and the A_2 are the only possible objects that can be exchanged across that link. A study of the reaction $\pi^- p \rightarrow \rho^0 n$ [23], shows that when the π and the A_2 are present, the A_2 begins to stand out for $t' - t'_{\min}$ greater than 0.3 GeV^2 . This conclusion is based on a study of the density matrix elements of the decaying ρ meson and seeing at what t' the PPD predictions break down, forcing the inclusion of the A_2 in the description. While this state of affairs is not expected to be universal, it does lend some support to our ignoring the A_2 at smaller values of t' .

If one is persuaded by the above-mentioned arguments that the PPD model will provide a good description of a process at small t' 's, there still remains the problem of what form factor is to be employed in the double-pomeron process. The standard form factors of the quasi-two-body reactions are not applicable here since they pertain to final states of definite spins--resonances or stable particles; while in the double-pomeron case these resonances have been specifically excluded. There is, however, a theoretical model of form factors that is valid in precisely this context. By solving the multiperipheral integral equation with variable masses for the external pions it is possible to derive the dependence of the high-energy elastic amplitudes on the

external masses, i.e.; the form factors [24]. Omitting details of the calculation, as they may be found in the reference quoted, I present here the final formula that is applicable to the present process: If two on-shell pions couple to a reggeon of spin $\alpha(u)$ and mass $(u)^{\frac{1}{2}}$, with a coupling $\beta(u)$, then the effect of taking one of the pions off-shell to a mass $(t)^{\frac{1}{2}}$, changes the coupling to

$$\beta(u,t) = \beta(u) \left[\frac{u_0 - \frac{\mu^2}{2} + \frac{u}{4}}{u_0 - \frac{1}{2}(\mu^2 - \frac{u}{2} + t)} \right]^{1+\alpha(u)} \quad (A.1)$$

In this formula u_0 is the scale factor and represents the (mass)² of the π - π resonance that goes into the kernel of the integral equation. Since there are at least two prominent resonances to be considered, namely the ρ - and the f -mesons, the authors of ref. [24] recommend a value of 1 GeV^2 for u_0 , which in addition to representing the mean of the two resonance masses also gives a good result in the numerical solution of the integral equation [24]. In principle the value of u_0 could be smaller, but not smaller than 0.5 GeV^2 , the mass squared of the meson.

In incorporating these form factors into our calculation the following considerations are relevant:[†]

(i) Since u represents the momentum transfer in the two elastic processes at the two ends of the pion link (see, for example, fig. 6), it is usually very small, since at high energies, the bulk of the elastic cross section comes from $u \lesssim 0.1 \text{ GeV}^2$. We may therefore drop factors like $u/2$ and $u/4$, as well as μ^2 in eq. (A.1), in comparison with u_0 and t . While t can be very small, it is only

[†] We are forced here to associate pomeron Regge poles with the two pomerons in the blobs (see fig. 6). This is a necessary evil for getting the form factors.

at larger t (around 0.15 or 0.2 GeV^2) that the form factor plays a significant role, providing the cut off. We shall ignore the slope of the pomeron and set $\alpha = 1$. The form factor then simplifies to

$$\beta(u, t) = \beta(u) \left(\frac{u_0}{u_0 - \frac{1}{2} t} \right)^{1+\alpha} \quad (\text{A.2})$$

(ii) This factor occurs to the fourth power in the double-pomeron cross section and leads to an overall form factor

$$f(t) = \left[\frac{u_0}{u_0 - \frac{1}{2} t} \right]^8 \simeq e^{4t/u_0} = e^{-4t'/u_0} \quad (\text{A.3})$$

for small t' . Choosing $u_0 = 1 \text{ GeV}^2$ leads to a form factor $f(t') = e^{-4t'}$ [while $u_0 = 0.5 \text{ GeV}^2$ would lead to $f(t') = e^{-8t'}$]. For simplicity this form factor was replaced by a flat one that simply cut off the integral [eq. (3.2)] at $t' = 1/4 \text{ GeV}^2$, leading to a result like eq. (3.3). If instead, one performs the integrations using the exponential form factors, one gets an answer in terms of exponential functions. Numerically, the result of such a calculation is about 20-25% larger than that coming from a simple formula like eq. (3.3). Considering the other approximations and uncertainties in this calculation, such as the value of u_0 , this difference is considered not important enough to justify abandoning the simple formula, eq. (3.3).

The following important point is worth underscoring. For the purposes of deriving the model independent bounds on asymptotic total cross sections that were mentioned in section 5B, it is sufficient to

know that there exists a physical region of nonzero measure in t' in which the production amplitude factorizes, as it does at the pole. On the other hand, to make a realistic estimate of the double-pomeron cross section, one must estimate the range in t' over which this factorization will persist. While the range of validity of the PPD hypothesis may be controversial, it seems very clear from a study of quasi-two-body reactions that there definitely exists a range of small t' over which the amplitude factorizes to a very good approximation and is dominated by the pion pole. For example, at very small t' , all density matrix elements approach the PPD values [19-21]. To extend this result from the quasi-two-body reactions to the double-pomeron process, one simply needs to increase the masses of the end blobs from the resonance region to the pomeron region. Is this increase likely to produce any significant changes? It appears not, from the following consideration. In ref. [20] we find that if in the reaction $\pi^- p \rightarrow \rho^0 \Delta^0$, we increase the mass of the π - π system till we reach the reaction $\pi^- p \rightarrow f^0 \Delta^0$, the density matrix elements in the very small t' region remain the same. One finds, for example that $\rho_{00} = 0.91 \pm 0.07$ for $0 < t' - t'_{\min} < 2\mu^2$, in ρ -decay, while $\rho_{00} = 0.88 \pm 0.11$ for $0 < t' - t'_{\min} < 5\mu^2$ in f -decay. The slight decrease in ρ_{00} in going from the ρ to the f -meson may be understood in terms of the increase in t'_{\min} and the increase in the range of t' .

REFERENCES

- [1] S. Mandelstam, Nuovo Cimento 30 (1963) 1127. See concluding remarks.
- [2] H. D. I. Abarbanel, G. F. Chew, M. L. Goldberger, and L. M. Saunders, Phys. Rev. Letters 26 (1971) 937.
- [3] R. J. Eden, High Energy Collision of Elementary Particles (Cambridge University Press, 1967), Chapter 10.
- [4] L. Bertocchi and E. Ferrari, High Energy Physics, Vol. II, Editor, E. H. S. Burhop (Academic Press, 1967).
- [5] G. F. Chew, T. Rogers, and D. R. Snider, Phys. Rev. D2 (1970) 765.
- [6] C. Sorensen, Phys. Rev. D6 (1972) 2554.
- [7] D. M. Chew, G. S. Abrams, H. H. Bingham, B. Y. Daugeras, W. B. Fretter, C. E. Friedberg, G. Goldhaber, W. R. Graves, A. D. Johnson, J. A. Kadyk, L. Stulte, G. H. Trilling, F. C. Winkelmann, G. P. Yost, D. Bogert, R. Hanft, F. R. Huson, D. Ljung, C. Pascaud, S. Pruss, and W. M. Smart, Lawrence Berkeley Laboratory Report LBL-2106.
- [8] M. Derrick, B. Musgrave, P. Schreiner, and H. Yuta, Argonne National Laboratory Report, ANL/HEP-7339-Revised.
- [9] O. Steinman, Helv. Phys. Acta 33 (1970) 275 and 347.
- [10] R. Leipes, G. Zweig, and W. Robertson, Phys. Rev. Letters 22 (1969) 433.
- [11] J. A. Rushbrooke and B. R. Webber, Search for Double-Pomeron Exchange in $pp \rightarrow pp\pi^+\pi^-$ at 6-25 GeV/c. Report submitted to the XVI International Conference on High Energy Physics, Batavia, September 1972.

- [12] A. H. Mueller, Production Processes at High Energy, *ibid* ref. [11].
- [13] J. D. Jackson, *Rev. Mod. Phys.* 37 (1969) 484.
- [14] G. L. Kane, Experimental Meson Spectroscopy, Editors: C. Boltay and A. H. Rosenfeld (Columbia University Press, 1970).
- [15] A. C. Hearn and S. D. Drell, *ibid* ref. [4].
- [16] H. P. Dürr and H. Pilkuhn, *Nuovo Cimento* 40 (1965) 899.
- [17] J. Benecke and H. P. Dürr, *Nuovo Cimento* 56 (1968) 269.
- [18] Gunter Wolf, *Phys. Rev.* 182 (1969) 1538.
- [19] J. A. Gaidos, R. B. Williams, J. W. Lamsa, C. R. Ezell, and F. T. Meiere, *Phys. Rev. D1* (1970) 3190.
- [20] N. N. Biswas, N. M. Cason, M. S. Farber, J. A. Helland, M. J. Hones, V. P. Kenney, J. T. McGrahan, J. A. Poirier, J. T. Powers, O. R. Sander, and W. D. Shephard, *Phys. Rev. D2* (1970) 2529.
- [21] R. O. Maddock, G. F. Pinter, D. Evans, C. Caso, F. Conte, D. Teodoro, G. Tomasini, H. Fesefeld, P. von Handel, H. Nagel, P. K. Schilling, G. Cecchet, L. Mandelli, S. Ratti, L. Tallone Lombardi, M. Chaumet, A. Daudin, M. Faccini, M. A. Jakiol, J. F. Lefur, C. Lewin, and J. Mallet, *Nuovo Cimento* 5A (1971) 433.
- [22] K. F. Galloway, R. A. Mercer, N. M. Cason, N. N. Biswas, V. P. Kenney, and W. D. Shephard, *Phys. Rev. D5* (1972) 1097.
- [23] J. T. Carroll, M. W. Firebaugh, W. D. Walker, J. A. J. Mathews, J. D. Prentice, and T. S. Yoon, *Phys. Rev. Letters* 27 (1971) 1025.
- [24] C. F. Chan and B. R. Webber, *Phys. Rev. D5* (1972) 933.

FIGURE CAPTIONS

- Fig. 1. A typical total cross section as a function of energy.
- Fig. 2. The elastic amplitude $M_{ab \rightarrow ab}(S, t)$ in the pomeron dominated region.
- Fig. 3. The rapidity plot for the process $ab \rightarrow ab \pi^+ \pi^-$ in the region of interest.
- Fig. 4. The multi-Regge production amplitude $M_{ab \rightarrow ab \pi^+ \pi^-}$ in the double-pomeron region.
- Fig. 5. The rapidity plot for the reaction $\pi^- p \rightarrow \pi^- p \pi^+ \pi^-$ in the region of interest.
- Fig. 6. The production amplitude $M_{\pi^- p \rightarrow \pi^- p \pi^+ \pi^-}$ at the pion pole.
- Fig. 7. The PPD model for $\gamma_{\pi\pi pp}(s_{\pi\pi}^C, t, t_1, t_2)$. The β 's are known by factorization from the elastic experiments.
- Fig. 8. The LZR model for $\gamma_{\pi\pi pp}(s_{\pi\pi}^C, t, t_1, t_2)$.
- Fig. 9. Rapidity plot for $pp \rightarrow pX$, with the "left-most" particle in X being a pion.
- Fig. 10. Calculating $d\sigma^\pi/dt d(M_X^2/S)$, the pion's contribution to the inclusion cross section. The prime on Σ' tells us to keep M_X^2 fixed when summing over P_d .
- Fig. 11. (a) The amplitude for the reaction $\pi^- p \rightarrow \rho^0 \Delta^0$ at the pion pole.
 (b) The amplitude for the same process, away from the pion pole, in the absorption model. The blobs denote initial and final state interactions.
- Fig. 12. (a) The reaction $\pi^- p \rightarrow \rho^0 \pi^- p$ in the PPD model.
 (b) The reaction $\pi^- p \rightarrow \rho^0 \pi^- \pi^0 p$ in the PPD model.

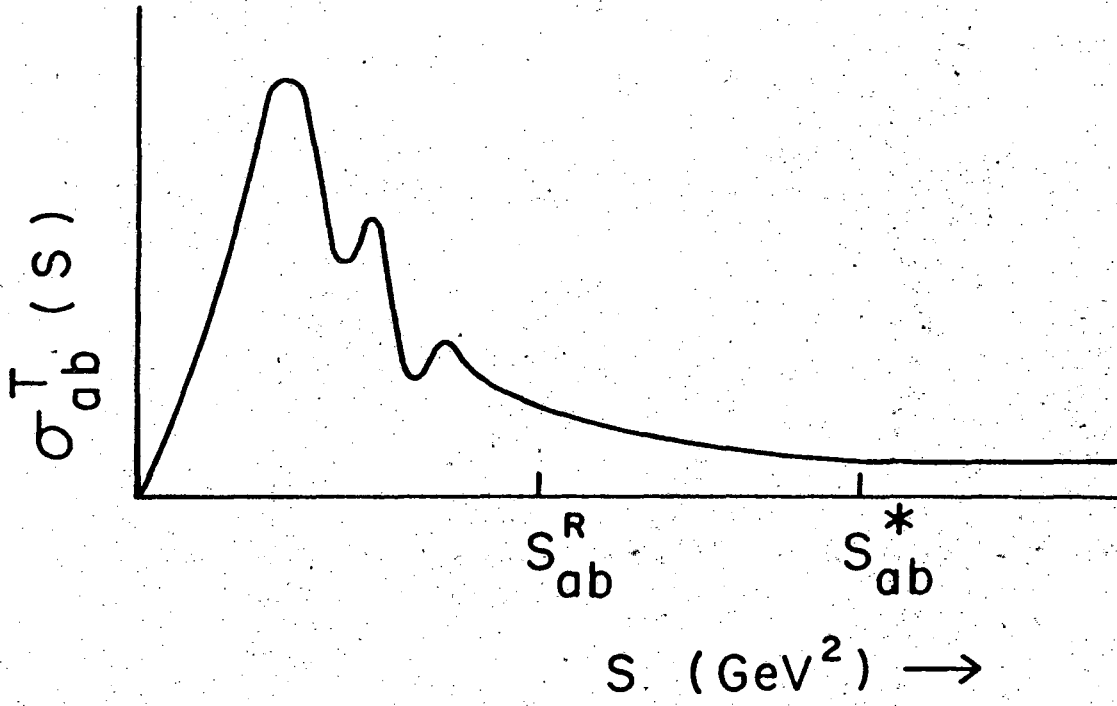

XBL737-3407

Fig. 1

$$M_{ab \rightarrow ab}(S, t) =$$

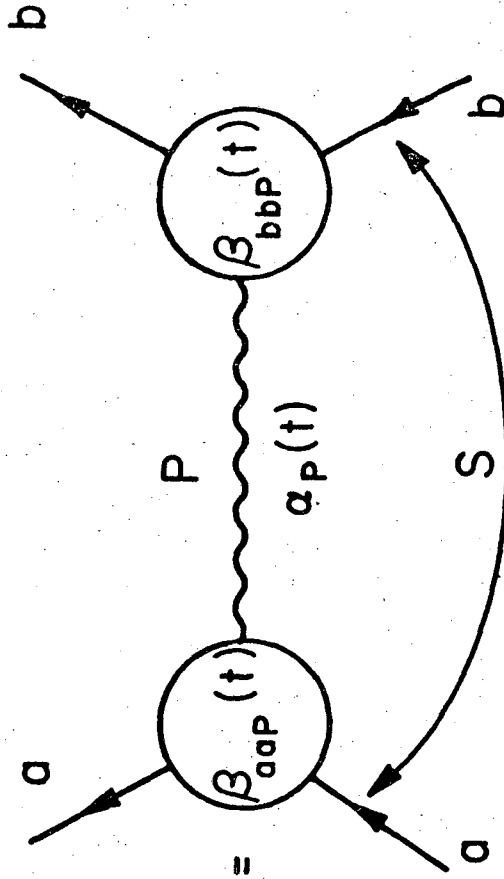

XBL737-3408

Fig. 2

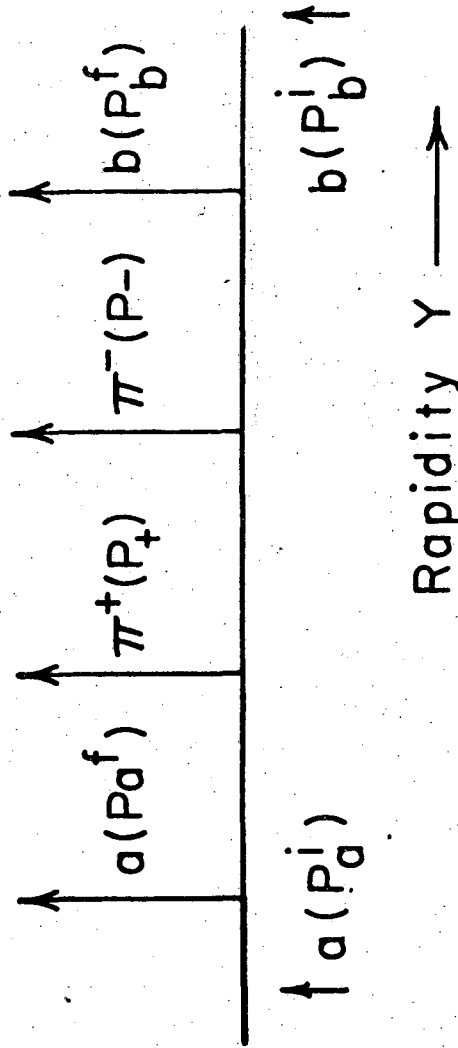

XBL737-3409

Fig. 3

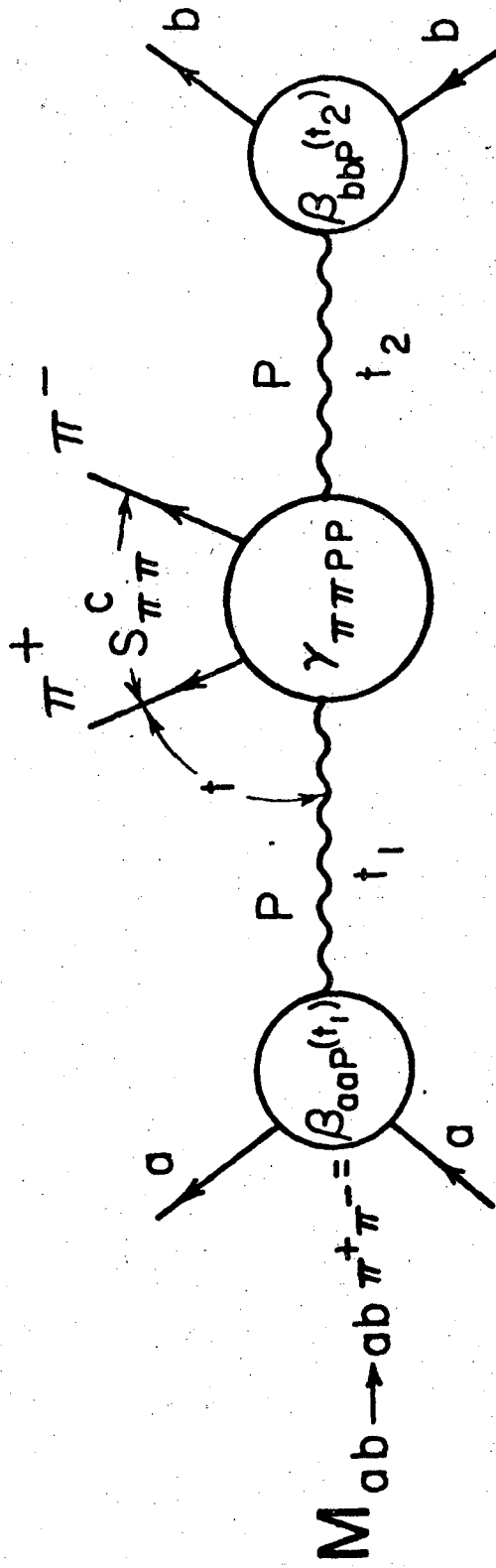

XBL737-3410

Fig. 4

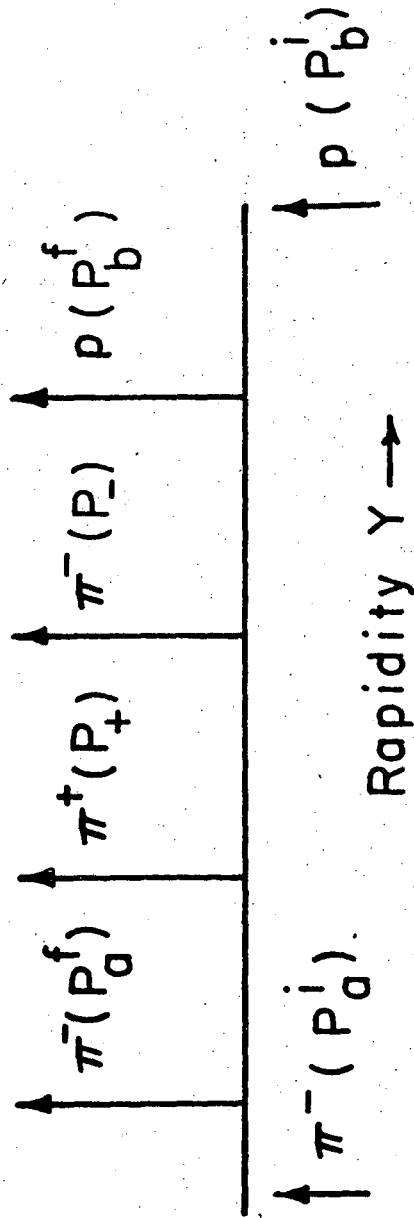

XBL737-3411

Fig. 5

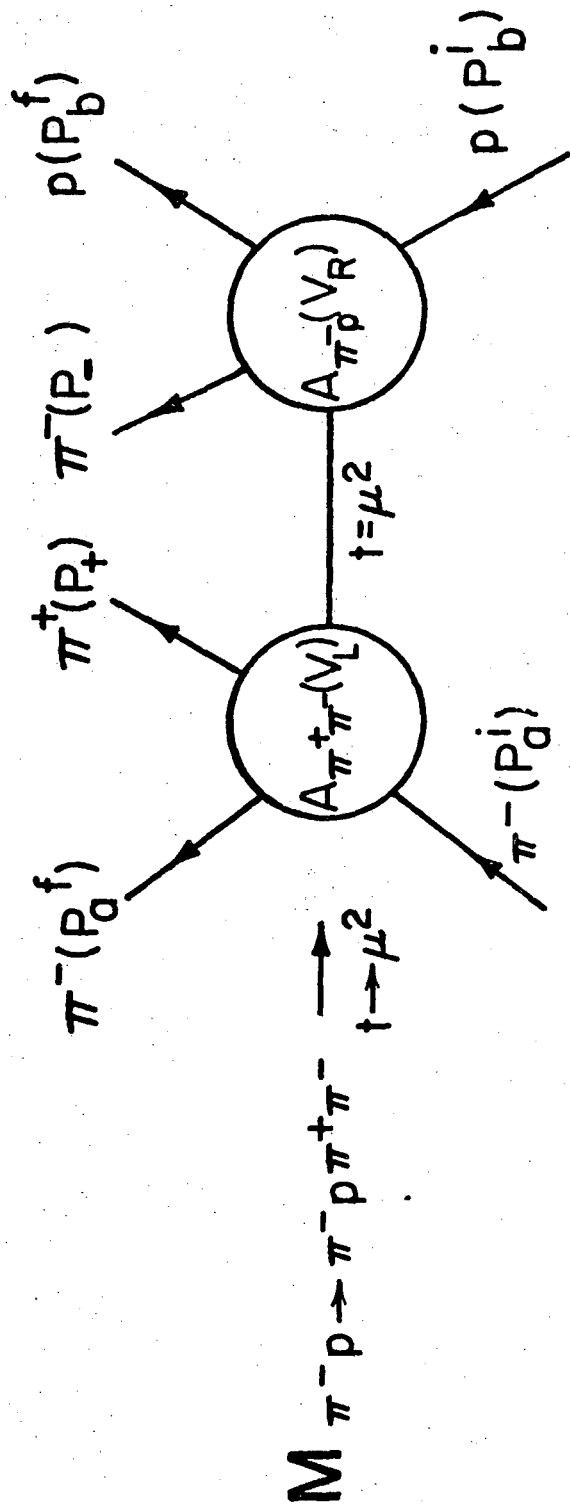

XBL737-3412

Fig. 6

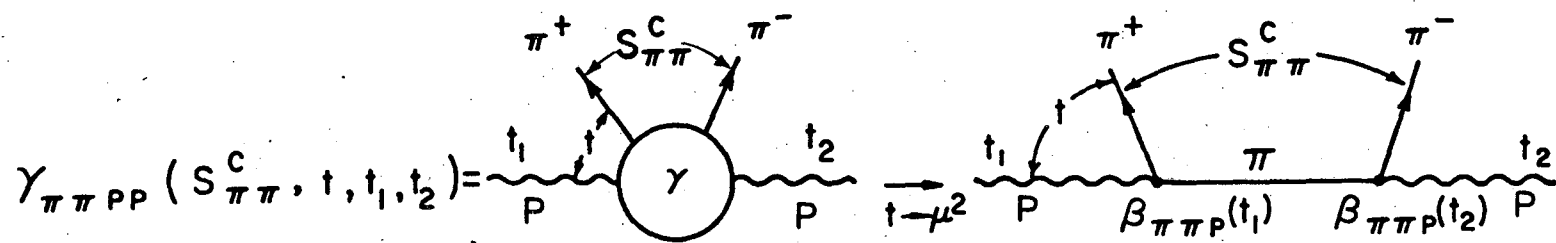

XBL737-3415

Fig. 7

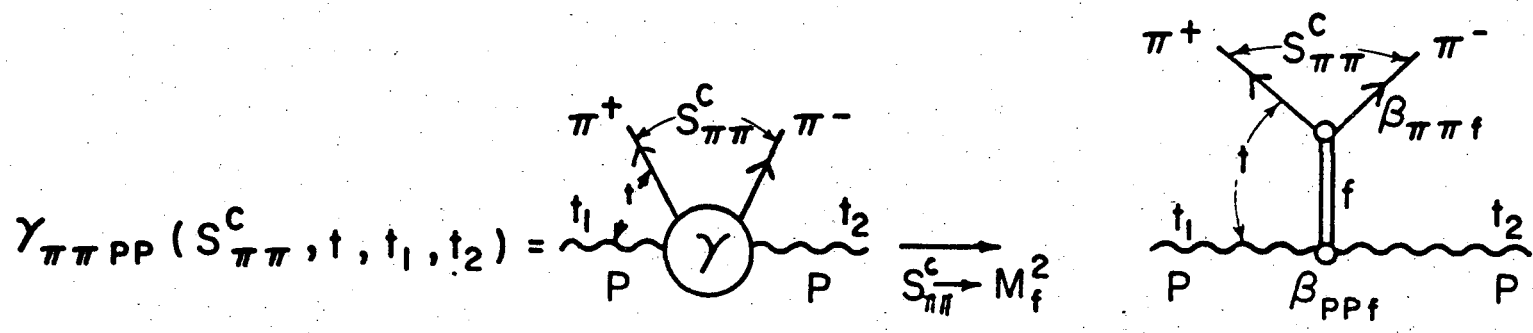

XBL737-3413

Fig. 8

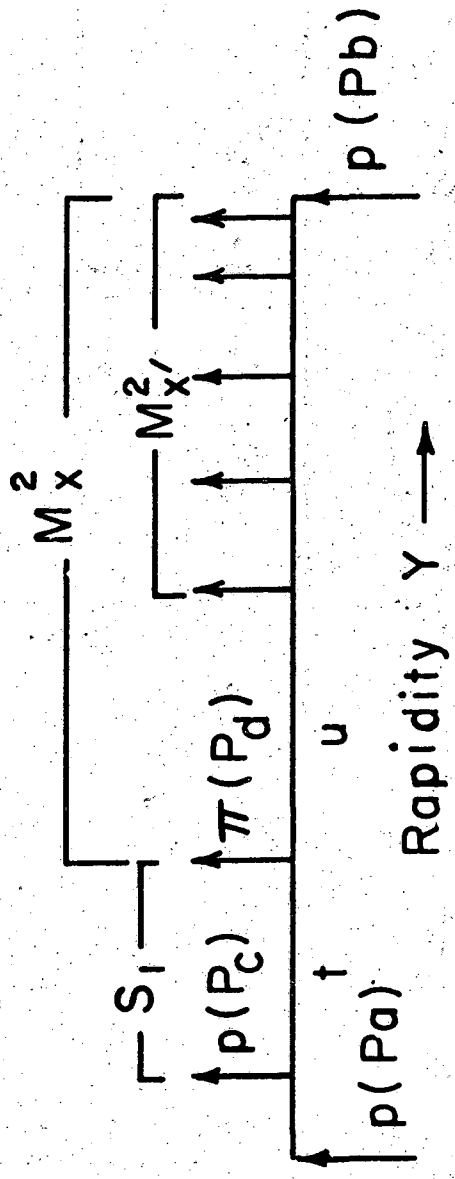

XBL737 - 3414

Fig. 9

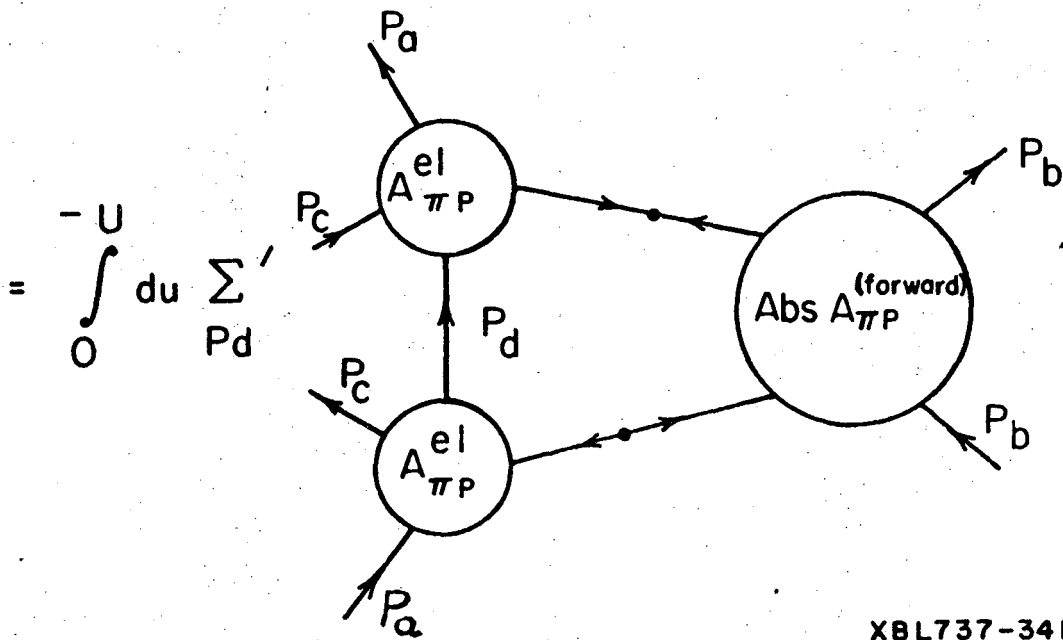
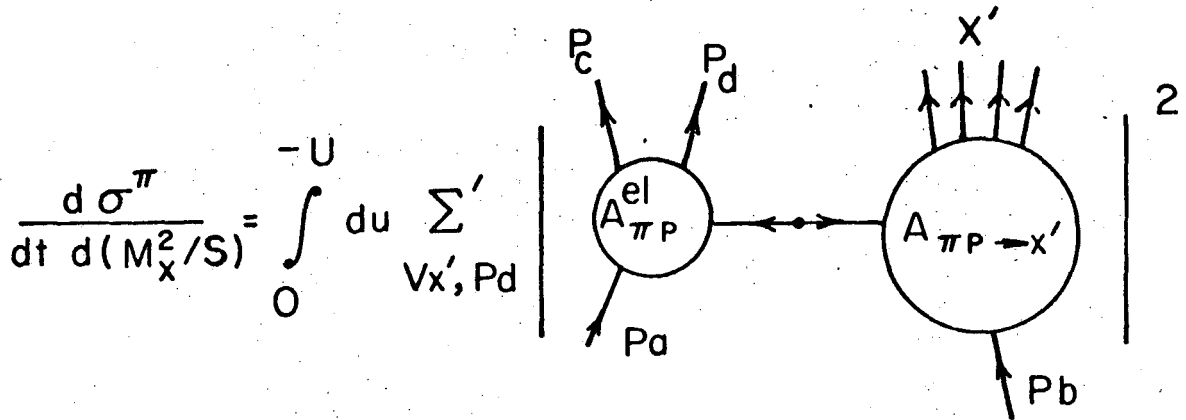

XBL737-3416

Fig. 10

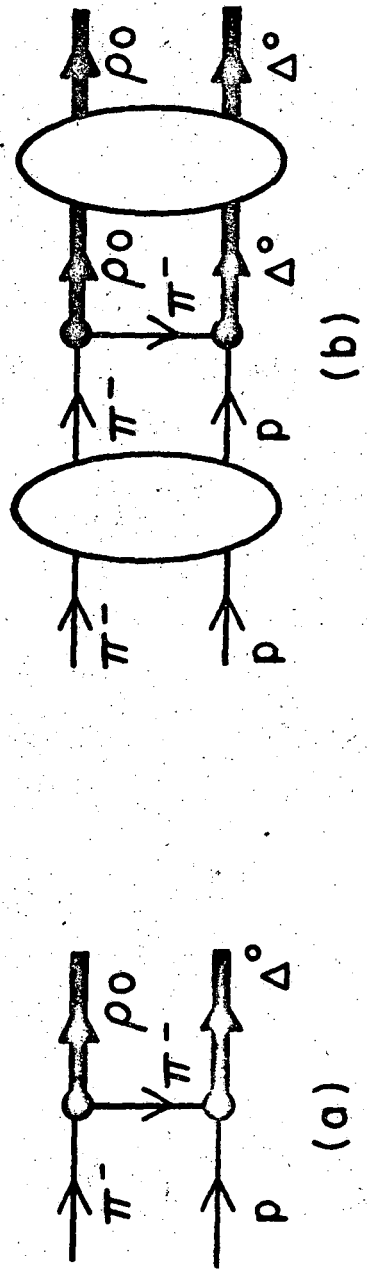

XBL7310-4176

Fig. 11

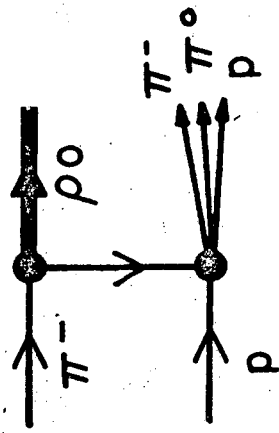

(b)

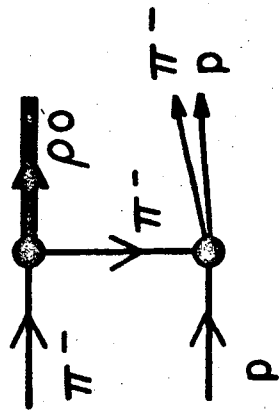

(a)

XBL7310 - 4175

Fig. 12

CHAPTER III

CRITICISM OF THE P' - ω EXCHANGE DEGENERACY
ARGUMENTS IN THE $pp \rightarrow px$ TRIPLE-REGGE REGION

Submitted to Physics Letters B

CRITICISM OF THE P' - ω EXCHANGE DEGENERACY ARGUMENTS
IN THE $pp \rightarrow pX$ TRIPLE-REGGE REGION[†]

R. Shankar

Lawrence Berkeley Laboratory
University of California
Berkeley, California 94720

March 28, 1974

ABSTRACT

The omission of off-diagonal terms (G_{ijk} , $i \neq j$) in the triple-Regge analysis of $pp \rightarrow pX$ on the grounds of P' - ω exchange degeneracy is questioned. It is pointed out that not only are compelling reasons absent for such a degeneracy but imposition thereof conflicts with simple G-parity considerations and leads to the neglect of probably significant off-diagonal terms. The practical problem of triple-Regge fitting in the presence of the off-diagonal terms resurrected here is briefly examined.

Consider the reaction $p(p_1) + p(p_2) \rightarrow p(p_3) + X$ in the triple-Regge region, $M^2 = (p_1 + p_2 - p_3)^2 \rightarrow \infty$, $(s/M^2) \rightarrow \infty$ and $t = (p_3 - p_1)^2$ fixed. The notation is defined by the following expansion of the inclusive cross section:

[†] Work supported by the U. S. Atomic Energy Commission.

$$\frac{d\sigma}{dt d(M^2/s)} = \frac{s_0}{s} \frac{1}{16\pi s_0} \sum_{i,j,k} \beta_{ppi}(t) \xi_i(t) \beta_{ppj}(t) \xi_j^*(t) \\ \times \left(\frac{s}{M^2}\right)^{\alpha_i(t)+\alpha_j(t)} g_{ijk}(t) \left(\frac{M^2}{s_0}\right)^{\alpha_k(0)} (\text{Im } \xi_k(0)) \beta_{ppk}(0) \cdot \text{mb} \cdot \text{GeV}^{-2} \quad (1)$$

In the above expansion, $s_0 = 1 \text{ GeV}^2$, $\beta_{ppi}(t)$ is the dimensionless coupling of Regge pole i to protons, and $\xi_i(t)$ is the signature factor for i , given by $[i - \cot(\frac{1}{2}\pi\alpha_i(t))]$ for even and $[-i - \tan(\frac{1}{2}\pi\alpha_i(t))]$ for odd signatures.† The β are normalized such that a single pole i contributes to the p-p total cross section an amount

$$\sigma_{pp,i}^t(s) = \frac{1}{s} [\text{Im } \xi_i(0)] \beta_{ppi}(0) \beta_{ppi}(0) \left(\frac{s}{s_0}\right)^{\alpha_i(0)} \text{GeV}^{-2} \quad (2)$$

The triple-Regge coupling $g_{ijk}(t)$, which has dimensions of GeV^{-2} will be measured in mb ($1 \text{ mb} \approx 2.5 \text{ GeV}^{-2}$).

Experimentalists usually parametrize the inclusive cross section as follows:

† With this choice of odd signature factor, $\beta_{pp\omega}^2(0)$ is positive while $\beta_{pp\omega}(0) \beta_{\bar{p}\bar{p}\omega}(0)$ is negative.

$$\frac{d\sigma}{dt d(M^2/s)} = \left(\frac{s_0}{s}\right) \sum_{i,j,k} G_{ijk}(t) \left(\frac{s}{M^2}\right)^{\alpha_i(t)+\alpha_j(t)} \left(\frac{M^2}{s_0}\right)^{\alpha_k(0)} \cdot \text{mb GeV}^{-2} \quad (3)$$

Therefore

$$G_{ijk}(t) = \frac{1}{16\pi s_0} \beta_{ppi}(t) \xi_i(t) \beta_{ppj}(t) \xi_j^*(t) g_{ijk}(t) (\text{Im } \xi_k(0)) \times \beta_{ppk}(0) \text{mb} \cdot \text{GeV}^{-2} \quad (4)$$

For the off-diagonal ($i \neq j$) terms let us define

$$\underline{G}_{ijk} = G_{ijk} + G_{jik} = 2 \text{Re } G_{ijk} \quad (5)$$

In phenomenological analyses (see, for example, refs. (1) or (2)) one considers the pomeron P , and the next family of lower poles, collectively referred to as R . The principal candidates for R are the P' and ω , since the ρ and A_2 couple weakly to protons.

My purpose here is to question an assumption usually made in such fits, that the P' and ω combine to form a real term R (as in p - p elastic scattering) so that the off-diagonal terms \underline{PRP} and \underline{PRR} are absent. One says for example, $\underline{PRP} = 2 \text{Re } G_{PRP} \approx 0$ on the grounds that the P is mainly imaginary while R is mainly real. Such reasoning, on the basis of exchange degeneracy, has a legitimate place in p - p elastic scattering, but not here. In the former case, the conditions $\beta_{ppP'} = \beta_{pp\omega}$ and $\alpha_{P'} = \alpha_{\omega}$, with opposite signatures

for P' and ω allow one to drop the interference terms between P and R in $d\sigma^{PP}/dt$. Evidently, in the case of $pp \rightarrow pX$, the degeneracy arguments are valid when $X = \text{proton}$, but in other cases, especially in the triple-Regge region, it is not at all obvious that the degeneracy should persist. In fact the indiscriminate imposition of such degeneracy conflicts with simple G-parity considerations.

Consider, for example, the term $G_{\underline{PRP}}$, together with eq. (4).

Assuming (perhaps legitimately) that $\beta_{ppP'} \approx \beta_{pp\omega}$, we can infer the vanishing of $G_{\underline{PRP}}$ only if $g_{PP'P} = g_{P\omega P}$. However, $g_{P\omega P}$ vanishes

from G-parity conservation, while no such restriction exists for

$g_{PP'P}$. We may therefore expect a nonzero $G_{\underline{PRP}} = G_{\underline{PP'P}}$. Existence of the P might be regarded as incompatible with exchange degeneracy.

As for the other off-diagonal term, $G_{\underline{PRR}}$, it will vanish unless both the labels R refer to the same object, P' or ω , once again due to G-parity conservation. Thus

$$G_{\underline{PRR}} = G_{\underline{PP'P'}} + G_{\underline{P\omega\omega}}. \quad \text{Assuming } \beta_{ppP'} = \beta_{pp\omega}$$

$$G_{\underline{PRR}} = (\text{common factors}) \left[g_{PP'P'} 2 \operatorname{Re} i \left[-i - \cot\left(\frac{1}{2}\pi\alpha_{P'}\right) \right] \operatorname{Im} \xi_{P'} \right.$$

$$\left. + g_{P\omega\omega} 2 \operatorname{Re} i \left[i - \tan\left(\frac{1}{2}\pi\alpha_{\omega}\right) \right] \operatorname{Im} \xi_{\omega} \right]$$

$$\sim \left[2 g_{PP'P'} + 2 g_{P\omega\omega} \right] \quad (7)$$

assuming for simplicity that $\xi_P(t) = i$. The \underline{PRR} term vanishes if $g_{PP'P'} = -g_{P\omega\omega}$. While this is possible, there exist no reasons why this must be the case.

Having resurrected the off-diagonal terms let us ask how important they may be. To get a feeling for this question, let us turn to the pion pole dominance model. In this model the ω is excluded since pions mediate the coupling between the reggeons i , j , and k (3). While the ω is excluded by G parity from PRP, and PPR, it is allowed in RRP, RPR, and RRR. Nonetheless the π exchange model should give some idea of the relative importance of various terms. Formulas for $g_{ijk}(t)$ calculated within this model have appeared in the literature (3,4) and have been numerically evaluated by Sorensen (5). For our present purpose, I have used the formulas for $g_{ijk}(0)$, the off-shell form factors of Sorensen, and the π -p elastic amplitudes of Barger and Phillips to calculate $G_{ijk}(0)$ and $d\sigma^{ijk}/dt d(M^2/s)|_{t=0}$, the contribution of each term to the inclusive cross section at $t = 0$. Table I contains the results for $x = 0.87$ and $s = 108, 752 \text{ GeV}^2$, together with the extrapolations of the measured cross section (1) to $t = 0$. We see from the table that the PRP term could be very significant ($\approx 30\%$). While absolute values of couplings and cross sections calculated in the model are dependent on the cut off provided by the off-shell factors, the relative magnitudes of the various terms are more reliable (7).

Resurrection of the off-diagonal term leaves the following options:

(A) We can fit the data with all six terms, and a $\pi\pi P$ term of magnitude given by Bishari (8). Considering the vast amount of data available, a good fit with these parameters should still be meaningful.

(B) We can try a fit with fewer terms, referring to Table I for guidance. For example, for x not too close to 1, we can try omitting the nonscaling terms PPR , RRR , and RPR if s is in the ISR range.

(C) We can follow Dash's prescription (9) for handling the P and P' as one unit. Dash claims that over an intermediate range of energies, the P and P' may be replaced to a good approximation by a single factorizable pole \tilde{P} , of intercept near 0.85 (10). According to Dash, the presently investigated intervals of (s/M^2) and (M^2/s_0) fall within the range of validity of this approximation. Dash in fact succeeds in fitting a lot of $pp \rightarrow pX$ data using no more than $\tilde{P}\tilde{P}$ and $\pi\pi P$ terms. Note that the leading off-diagonal term $\underline{PP}'P$ is contained in $\tilde{P}\tilde{P}$, since each \tilde{P} represents the combined effect of P and P' . While the equivalent pole \tilde{P} must give way to separate P and P' when (s/M^2) and (M^2/s_0) go beyond the intermediate range specified, the phenomenological simplicity emphasized by Dash may allow an economical description of the triple-Regge region.

In conclusion, this paper emphasizes the absence of compelling reasons for $P'-\omega$ exchange degeneracy in the triple-Regge region of $pp \rightarrow pX$ and stresses that imposition of such degeneracy conflicts with G-parity conservation. Of the two off-diagonal terms reinstated by the above arguments, the \underline{PRP} term seems especially significant, according to the pion exchange model. Meaningful data analysis must find a means of including at least this term.

I am very grateful to Geoffrey Chew for several useful discussions and in particular for drawing my attention to Dash's work.

REFERENCES

1. K. Abe et al., Phys. Rev. Letters 31 (1973) 1527.
2. D. P. Roy and R. G. Roberts, Triple-Regge Analysis of $pp \rightarrow pX$ and Some Related Phenomenon-A Detailed Study, Rutherford Lab Preprint, RL-74-022 (T79), January 1974.
3. M. L. Goldberger, Multiperipheral Models and High Energy Processes, Princeton University Preprint, PURC-4159-42, July 1971.
4. H. D. I. Abarbanel et al., Phys. Rev. Letters 26 (1971) 937.
5. C. Sorensen, Phys. Rev. D6 (1972) 2554.
6. V. Barger and R. J. N. Phillips, Phys. Rev. 187 (1969) 2210.
7. The π -exchange model predicts that the ratios G_{RRX}/G_{PPX} ($X = P$ or R) will be large and relates this largeness qualitatively and quantitatively to the small pion mass. The measured ratios seem to confirm this prediction. For a detailed analysis see "The Connection Between the Largeness of G_{RRX}/G_{PPX} and the Smallness of the Pion Mass", R. Shankar, Lawrence Berkeley Laboratory Preprint LBL-2670 (in preparation).
8. M. Bishari, Phys. Letters 38B (1972) 510.
9. Jan W. Dash, Phys. Rev. D9 (1974) 200.
10. For a discussion of the effective pole, \tilde{P} , concept see, Weakly Recurrent Pomerons, G. F. Chew, Review Talk at the Fifth International Conference on High Energy Collisions, Stony Brook, August 1973.

Table I. The predictions of the π -exchange model for G_{ijk}
 and $\frac{d\sigma^{ijk}}{dt d(M^2/s)}$ in $\text{mb}\cdot\text{GeV}^{-2}$, at $x = 0.87$, $t = 0$.

	PPP	PPR	RRP	RRR	<u>PRP</u>	<u>PRR</u>	Total $\frac{d\sigma}{dt d(M^2/s)} \Big _{t=0}$ (theory)	Total $\frac{d\sigma}{dt d(M^2/s)} \Big _{t=0}$ (extrapolation of experi- ment (1))
$G_{ijk}(0)$	0.86	1.39	8.1	12.6	3.32	5.3		
<u>$s = 108 \text{ GeV}^2$</u>								
$\frac{d\sigma^{ijk}}{dt d(M^2/s)} \Big _{t=0}$	6.6	2.6	8.1	3.4	9.2	3.9	34	80
%	19.4	7.6	23.8	10.0	27.0	11.4		
<u>$s = 752 \text{ GeV}^2$</u>								
$\frac{d\sigma}{dt d(M^2/s)} \Big _{t=0}$	6.6	1.0	8.1	1.3	9.2	1.5	28	68
%	24.0	3.6	29.2	4.7	33.2	5.4		

CHAPTER IV

ROLE OF THE PION MASS IN TRIPLE-REGGE PHYSICS

Submitted to Nuclear Physics B

ROLE OF THE PION MASS IN TRIPLE-REGGE PHYSICS*

R. Shankar

Lawrence Berkeley Laboratory
University of California
Berkeley, California 94720

April 25, 1974

Abstract

This paper is an extension of the investigations of Abarbanel et al., who examined asymptotic total cross sections in a multiperipheral model and obtained the surprising result that the scale for the cross sections is provided not by μ , the mass of the exchanged pion (as anticipated on geometrical grounds) but by m_V , the central mass of the dominant low energy π - π resonance entering the kernel. In this paper the role of the pion mass in triple-Regge physics is clarified by examining the pion pole dominance model for the triple-Regge couplings g_{ijk} . It is found that m_V provides the scale for the inclusive link and that for this reason the couplings g_{ijk} depend very little on the intercept α_k of the exchanged reggeon. In the exclusive links if $i = j =$ pomeron, m_V once again is the only active energy scale, whereas if $i = j = R$, the reggeons of intercept 0.5 or less, the pion mass enters the couplings g_{RRk} in an essential way. It is shown that the smallness of μ^2/m_V^2 is responsible for the largeness of the ratios g_{RRk}/g_{PPk} . These features of the model, which are in qualitative agreement with experiment, are put to a quantitative test.

* Work done under the auspices of the U.S. Atomic Energy Commission.

I. Introduction

The theorist's view of the role of the pion mass μ in hadronic processes has an interesting history. Following Yukawa's discovery that exchanging a particle of mass m produces a force of range $1/m$, there has existed the belief, based on geometrical reasoning, that hadron-hadron cross sections would be controlled by the lightest hadron, the pion. The corresponding cross section $\pi\mu^{-2} \approx 60$ mb, is in fact of the order of magnitude of observed high energy total cross sections. The geometrical view was nevertheless challenged by the investigation of Abarbanel, Chew, Goldberger, and Saunders [1] who calculated meson-meson asymptotic total cross section within a multiperipheral model involving an N -dimensional multiplet of pions obeying an $SU(n)$ symmetry. They obtained the surprising result that as the pion mass μ was reduced to zero, the total cross section approached a smooth limit of order

$$\sigma^t(\infty) \sim \frac{16\pi^3}{Nm_V^2} \quad (1)$$

where m_V is the central mass of the dominant low-energy resonance multiplet in elastic π - π scattering. For $m_V \approx 900$ MeV and $N=8$, they obtained a cross section of about 30 mb, acceptable in magnitude but totally non-geometric in character -- the scale of the cross section being provided by the direct channel mass m_V rather than the t -channel mass μ .

Since m_V is the only mass left in the problem, it also sets the scale for the Regge expansion. The authors of ref. [1] obtain for the asymptotic form of the absorptive part of the elastic amplitude, the expression of the form

$$A(S, 0) \underset{S \rightarrow \infty}{\sim} 16\pi^3 \left(\frac{S}{m_V^2}\right)^\alpha \quad (2)$$

due to the leading pole α . Clearly the same mass m_V will set the scale for the Regge expansions in meson-baryon and baryon-baryon amplitudes calculated within this model.

It has been known phenomenologically that a universal scale factor $S_0 = 1\text{GeV}^2 (\approx m_V^2)$ is the natural one for Regge expansions[†], in the sense that if one expands the absorptive part of the forward elastic amplitude for a typical process as

$$A(S, 0) \underset{S \rightarrow \infty}{\sim} \beta_P \left(\frac{S}{S_0}\right)^{\alpha_P} + \sum_R \beta_R \left(\frac{S}{S_0}\right)^{\alpha_R} + \dots \quad (3)$$

the residue β_P of the pomeron is commensurate in magnitude with the β_R corresponding to the lower (intercept ≈ 0.5) trajectories. [2, 3]

Thus the largeness of the variable (S/S_0) is a direct and reliable measure of the convergence of the expansion. In contrast, if one uses μ^2 as the scale factor; one obtains for the same amplitude an expansion:

$$\begin{aligned} A(S, 0) \underset{S \rightarrow \infty}{\sim} & \beta_P \left(\frac{\mu^2}{S_0}\right)^{\alpha_P} \left(\frac{S}{\mu^2}\right)^{\alpha_P} + \sum_R \beta_R \left(\frac{\mu^2}{S_0}\right)^{\alpha_R} \left(\frac{S}{\mu^2}\right)^{\alpha_R} + \dots \quad (4) \\ = & \beta'_P \left(\frac{S}{\mu^2}\right)^{\alpha_P} + \sum_R \beta'_R \left(\frac{S}{\mu^2}\right)^{\alpha_R} + \dots \end{aligned}$$

In this expansion the largeness of (S/μ^2) is not a reliable measure of the convergence of the series, since the relatively large residues accompanying the lower poles delay the convergence in this variable.

[†] In this paper the scale factors S_0 and m_V^2 (both set equal to 1GeV^2) will be used interchangeably. In some theoretical contexts the scale factor will be denoted by m_V^2 to emphasize its origin within the model, while in a phenomenological context the symbol S_0 will be preferentially used.

Are we to infer from the above that the only role of the pion mass is to make plausible (due to its smallness) the hypothesis of pion-pole dominance in each link of the multiperipheral chain? What about the geometrical connection between the pion mass and hadronic cross sections?

The answer to this question is implicit in ref. [1]. We find there that only the part of the total cross section arising from Regge poles substantially above zero in the t-channel angular momentum plane (and hence important at high energies) is μ^2 independent, whereas that associated with lower poles (and hence dominant at low energies) is sensitive to μ^2 . To see how this comes about let us examine the trace of the kernel[†] used in ref. [1]:

$$\text{Tr } K_\lambda = \frac{1}{16\pi^3(\lambda+1)} \int_{-\infty}^0 \frac{dt}{(\mu^2-t)^2} \left[\frac{-t}{m_V^2 - 2t} \right]^{\lambda+1} \quad (5)$$

where λ is the angular momentum in the t-channel. For poles substantially above $\lambda=0$ ($\lambda \gtrsim 1/2$) the dependence on μ^2 is feeble and to a good approximation one may set $\mu^2 = 0$. [1] For poles around $\lambda \approx 0$ and below, the dependence on μ^2 is crucial and in fact for $\lambda \leq 0$, setting $\mu^2 = 0$ will cause the divergence of the integral. For poles in this region the physical value of μ^2 will enter the description introducing an additional energy scale.[‡] Herein lies the possibility of a reconciliation with the geometric ideas. If we consider a process like $\pi\pi \rightarrow VV$ (where V is the π - π resonance) due to one pion exchange, the cross section will indeed diverge if μ^2 is set equal to zero (in accordance with geo-

[†] This is the only place where μ enters as the mass of the exchanged object. Its occurrence as the mass of the external particles elsewhere does not interest us.

[‡] The fact that such low lying poles are sensitive to μ^2 is only of academic interest since they do not feature in phenomenological Regge fits.

metrical ideas), and we must use the physical value of μ^2 . This dependence on μ^2 does not, however, conflict with the results of Abarbanel et al., since the energy dependence of this cross section corresponds to a low lying pole at $\lambda = 2\alpha_\pi - 1 = -1$. It is only when an infinite number of exclusive processes, involving an infinite number of pion links add up inclusively to produce a high lying Regge pole that the dependence on μ^2 drops out.

After this lengthy prelude let us turn to the question at hand, the role of the pion mass in triple-Regge physics. While all reactions of the type $ab \rightarrow cX$ fall under the latter category, we will confine ourselves to a reaction $p(p_1) + p(p_2) \rightarrow p(p_3) + X$ which alone has been investigated in detail. In the limit $M^2 = (p_1 + p_2 - p_3)^2 \rightarrow \infty$, $(S/M^2) \rightarrow \infty$ and $t = (p_3 - p_1)^2$ fixed, let us write the inclusive cross section as

$$\frac{d\sigma}{dt d(M^2/S)} = \left(\frac{S_0}{S}\right) \sum_{i,j,k} G_{ijk}(t) \left(\frac{S}{M^2}\right)^{\alpha_i(t) + \alpha_j(t)} \left(\frac{M^2}{S_0}\right)^{\alpha_k(0)} \quad (6)$$

where the coefficients G_{ijk} are measured in $\text{mb} \cdot \text{GeV}^{-2}$. Experiment-
alists presently use two trajectories, the pomeron (P) of intercept
unity and a lower trajectory (R) of intercept around 0.5 or below. Only
diagonal terms ($i=j$ in G_{ijk}) are employed. The results from a variety
of sources are summarized in Table I. We shall discuss this table in
greater detail later. For the present let us note two conspicuous
features:

(i) The coefficients G_{iik} have only a feeble dependence on the
inclusive reggeon k , that is G_{iiP} and G_{iiR} are commensurate in
magnitude (reflecting the suitability of $S_0 = 1 \text{ GeV}^2$ as the scale factor
in this link).

Some readers may object to the above generalization on the

grounds that there are fits such as refs. [5, 6] in which G_{RRP} is substantial while G_{RRR} is absent. I would like to draw the attention of such readers to ref. [5] where it is pointed out that even a substantial coefficient G_{RRR} (of the same order as G_{RRP}) could easily be omitted in a fit since its presence makes little difference to the inclusive cross section and the χ^2 values. Notice, however, that fits in which G_{RRR} does occur (refs. [4, 7]), it does so with a magnitude similar to G_{RRP} .

(ii) The coefficients G_{iik} have a marked dependence on the reggeon i : the coefficients G_{RRk} are an order of magnitude larger than the coefficients G_{PPk} . Consequently the variable (S/M^2) does not provide a reliable index of the convergence of the expansion in the two exclusive links. From our earlier discussion it would seem that a new energy scale has made its appearance and is discriminating between P and R .

In this paper both these features will be related to the role of the pion mass in the triple-Regge region. The analysis will be based on the pion pole dominance model for triple-Regge couplings. While the model formulas for these couplings have appeared in the literature [8] and have been numerically evaluated by Sorensen [9] my purpose here is to focus attention on the following features of the model which have not been emphasized in the past:

(i) The inclusive link carrying reggeon k (Fig. 2) has a smooth behavior as $\mu^2 \rightarrow 0$. In this limit the only energy scale is S_0 , a circumstance which will be seen to be responsible for the weak dependence of G_{ijk} on the reggeon k .

(ii) The μ^2 dependence in the exclusive links is similar to that encountered in ref. [1]: If the links carry high spin reggeons i and j , μ^2 may be set equal to zero and $m_V^2 = S_0$ provides the scale, while if

i and j are low spin reggeons the physical value of μ^2 enters in an essential way. The crucial difference here is that even the trajectories R of intercept ≈ 0.5 (which are very much a part of the triple-Regge fits to the data) are classified as low spin reggeons. The entry of the small pion mass into the coefficients G_{RRk} is seen to be the cause of the large ratios G_{RRk}/G_{PPk} and the resultant delay in the convergence of the triple-Regge series in the variable (S/M^2) .

The paper is organized as follows. The notations and conventions are established in Section II. A brief discussion of the model, leading to the formulas for the triple-Regge couplings, is presented in Section III. These formulas are analyzed in Section IV to display the role of the pion mass. The quantitative predictions of the model are compared with experiment in Section V.

II. Notations and Conventions

From a theoretical standpoint the following expansion of the inclusive cross section is more appropriate than eq. (6):

$$\begin{aligned} \frac{d\sigma}{dt d(M^2/S)} &= \left(\frac{S_0}{S}\right) \cdot \frac{1}{16\pi S_0} \sum_{i,j,k} \beta_{ppi}(t) \xi_i(t) \beta_{ppj}(t) \xi_j^*(t) \\ &\times \left(\frac{S}{M^2}\right)^{\alpha_i(t)+\alpha_j(t)} \cdot g_{ijk}(t) \text{Im} \xi_k(0) \cdot \left(\frac{M^2}{S_0}\right)^{\alpha_k} \beta_{ppk}(0) \text{mb} \cdot \text{GeV} \end{aligned} \quad (7)$$

In this expansion $\beta_{ppi}(t)$ is the coupling of reggeon i to protons, $\alpha_i(t)$ its trajectory ($\alpha_i(0) \equiv \alpha_i$) and $\xi_i(t)$ its signature factor given by $[i - \cot(\frac{1}{2}\pi\alpha_i(t))]$ for even and $[-i - \tan(\frac{1}{2}\pi\alpha_i(t))]$ for odd signatures. The triple-Regge coupling $g_{ijk}(t)$ has dimensions GeV^{-2} and will be measured in mb ($1 \text{ mb} = 2.5 \text{ GeV}^{-2}$). The normalization of the β 's is

such that a single pole i contributes to the total cross section an amount

$$\sigma_{pp,i}^t(S) \stackrel{S \rightarrow \infty}{=} \frac{1}{S} \cdot [\text{Im } \xi_i(0)] \beta_{ppi}^2(0) \left(\frac{S}{S_0}\right)^{\alpha_i} \text{GeV}^{-2} \quad (8)$$

With the present choice of signature factors $\beta_{pp\omega}^2(0)$ and $\beta_{ppP'}^2(0)$ will both be positive. Since only $\beta_{ppi}^2(0)$ is defined by eq. (8) we will agree that $\beta_{ppi}(0)$ is the positive square root of $\beta_{ppi}^2(0)$. This defines the sign of g_{ijk} . A comparison of eqs. (7 and 8) provides the connection between the triple-Regge coefficients G_{ijk} and the triple-Regge couplings g_{ijk} :

$$G_{ijk}(t) = \frac{1}{16\pi S_0} \beta_{ppi}(t) \xi_i(t) \beta_{ppj}(t) \xi_j^*(t) \beta_{ppk}(0) [\text{Im } \xi_k(0)] g_{ijk} \text{mb} \cdot \text{GeV}^{-2} \quad (9)$$

For the off-diagonal coefficients ($i \neq j$) let us define the quantity

$$G_{\underline{ijk}} = G_{ijk} + G_{jik} = 2 \text{Re } G_{ijk} \quad (10)$$

In the fits carried out so far, the Regge poles used are the pomeron (P) and the next family of poles -- referred to collectively as R. The effect of pion exchange is included either directly by means of a $\pi\pi P$ term or indirectly, by using $\alpha_R(t) = 0.2+t$ instead of the conventional $\alpha_R(t) = 0.5+t$ in the RRP term. In some cases $\alpha_R = 0.2+t$ is used uniformly. In all the fits carried out so far, only diagonal coefficients G_{iik} are employed. The results from the analyses of NAL [4, 5], ISR [6] and global [7] data are presented in Table I. The trajectories employed in the different fits are indicated there. While both refs. [6] and [7] give analytic expressions for $G_{iik}(t)$, the values at specific t -values are presented here so that they may be compared with other measurements. The regions of small $|t|$ (defined arbitrarily by $|t| <$

0.16 GeV^2) is avoided since it seems controversial -- coefficients which turn over in this region according to some fits (e. g., G_{RRP} of ref. [7] do not turn over according to others (ref. [6])).

As pointed out in the introduction, our object here is to understand why the coefficients G_{iik} have a feeble dependence on reggeon k and a strong dependence on reggeon i . If we recall that β_{PPi} have about the same magnitude for P and R and that $|\xi_P(t)|^2$ and $|\xi_R(t)|^2$ are also of similar magnitude, we deduce from eq. (9) that g_{iik} will exhibit a similar dependence on the indices i and k at least for small $|t|$.^{*} In the next two sections we will therefore examine g_{iik} within the pion pole dominance model and understand how the pion mass μ produces the above mentioned dependence on i and k . We will finally return to G_{iik} in Section V when the model is compared with experiment quantitatively.

III. The Pion Pole Dominance Model for g_{ijk}

Since this model has been discussed at length in refs. [8] and [9] only a brief description will be provided here, emphasizing those aspects which are germane to the subsequent discussions. Among all the exclusive events contributing to the inclusive cross section, consider those in which the particle from X closest to the proton in rapidity (labelled 4 in Fig. 1) is a pion, $\pi(p_4)$. When $u = (p_3 + p_4 - p_1)^2 = \mu^2$, the amplitude factorizes:

* We know from total cross section measurements that $\beta_{ppP}(0) \approx \beta_{ppR}(0)$. For $\alpha_R = 0.5$ and $\alpha_P = 1$, $|\xi_R|^2 = 2|\xi_P|^2$ at $t=0$. We are assuming that this commensurability will persist for modest values of $|t|$.

$$M_{pp \rightarrow p\pi X'}(u) \xrightarrow[u \rightarrow \mu^2]{} \frac{M_{\pi p \rightarrow \pi p} M_{\pi p \rightarrow X'}}{u - \mu^2} \quad (11)$$

The key assumption in the model (based on the smallness of μ^2) is that in the physical region ($u < 0$) the amplitude is given by the factorized form of eq. (11) modified by form factors which account for the off-shell nature of the exchanged pion. This assumption has been tested against experiment for the case $X' = \pi p$ and found to be reliable. [11]

Calculations of the inclusive cross section in the triple-Regge region from the model amplitude and the identification of g_{ijk} are schematically represented in Fig. 2. The details may be found in refs. [8, 9]. The following is the result

$$g_{ijk}(t) = \frac{\Gamma(1+\alpha_k) \times 3}{16\pi^3} \left(\frac{1}{2.5}\right) \cdot \int_{-\infty}^0 du \left[2\sqrt{\frac{ut}{m_V^2}} \sinh q \right]^{\alpha_i(t)+\alpha_j(t)}$$

$$\left(\frac{u}{t}\right)^{\frac{1+\alpha_k}{2}} \frac{1}{(\mu^2 - u)^2} \cdot P_{\alpha_i(t)+\alpha_j(t)}^{-1-\alpha_k} (\coth q) \beta_{\pi\pi i}(t, u, \mu^2) \beta_{\pi\pi j}(t, u, \mu^2)$$

$$\times \beta_{\pi\pi k}(0, u, u) \text{ mb.} \quad (12)$$

One considers in this model just the vacuum trajectories P and P' , since the ω is forbidden by G-parity, while the ρ and A_2 couple weakly to the external protons. Thus the three types of pions that can be exchanged are accounted for by a factor 3 in eq. (12). The scale factor $m_V^2 = S_0 = 1 \text{ MeV}^2$ implicit in refs. [8, 9] is explicitly displayed here and $\cosh q = \frac{\mu^2 - t - u}{2\sqrt{ut}}$. The residue $\beta_{\pi\pi i}(t, y^2, z^2)$ is the coupling of a reggeon i of mass \sqrt{t} to pions of mass y and z . Only $\beta_{\pi\pi i}(t, \mu^2, \mu^2) \equiv \beta_{\pi\pi i}(t)$ is measurable[†] and we shall use the ABFST [12] form

[†] The coupling $\beta_{\pi\pi i}(t)$ is that obtained from Regge fits using the standard scale factor of 1 GeV^2 .

factors to go off-shell:‡

$$\beta_{\pi\pi i}(t, y^2, z^2) = \beta_{\pi\pi i}(t) \left[\frac{m_V^2 + t/4 - \mu^2}{m_V^2 - 1/2(y^2 + z^2 - t/2)} \right]^{1+\alpha_i(t)} \quad (13)$$

For future reference, let us note that for t , y^2 and z^2 much smaller than m_V^2 , we can use the approximation

$$\beta_{\pi\pi i}(t, y^2, z^2) \simeq \beta_{\pi\pi i}(t) e^{\frac{1/2(y^2 + z^2)(1+\alpha_i)}{m_V^2}} \quad (14)$$

IV. The Role of the Pion Mass

As given by eq. (12) the coupling $g_{ijk}(t)$ defies any simple analysis. However, the formula simplifies greatly at $t=0$:

$$g_{ijk}(0) = \frac{3}{16\pi^3} \frac{1}{1+\alpha_k} \cdot \frac{1}{(2.5)} \int_{-\infty}^0 du \frac{1}{(\mu^2 - u)^2} \left(\frac{\mu^2 - u}{m_V^2} \right)^{\alpha_i + \alpha_j} \left(\frac{-u}{\mu^2 - u} \right)^{1+\alpha_k} \beta_{\pi\pi i}(0, \mu^2, u) \beta_{\pi\pi j}(0, \mu^2, u) \beta_{\pi\pi k}(0, u, u) \text{ mb} \quad (15)$$

and using eq. (14)

$$g_{ijk}(0) = \frac{3}{16\pi^3} \frac{1}{1+\alpha_k} \cdot \frac{1}{(2.5)} \beta_{\pi\pi i}(0) \beta_{\pi\pi j}(0) \beta_{\pi\pi k}(0) \times \int_{-\infty}^0 du \frac{1}{(\mu^2 - u)^2} \cdot \left(\frac{\mu^2 - u}{m_V^2} \right)^{\alpha_i + \alpha_j} \left(\frac{-u}{\mu^2 - u} \right)^{1+\alpha_k} e^{\left[\omega_{ijk} \cdot \left(\frac{u}{m_V^2} \right) \right]} \text{ mb} \quad (16)$$

‡ Sorensen uses the form factor $\left[\frac{m_V^2}{m_V^2 - 1/2(y^2 + z^2 - t/2)} \right]^{1+\alpha_i(t)}$ which

doesn't reduce to unity on shell. For the range of small $|t|$ he considers, this causes little error.

where $\omega_{ijk} = \frac{\alpha_i + \alpha_j + 2}{2} + 1 + \alpha_k$ varies in the limited range 3-4 for conventional P and R trajectories. Let us begin by examining the dependence of $g_{ijk}(0)$ on reggeon k. We see that $(-u/(\mu^2 - u))^{1+\alpha_k}$ smoothly approaches unity as $\mu^2 \rightarrow 0$ and may be evaluated in that limit. The dependence of $g_{iik}(0)$ on k is then due to the factors $(1+\alpha_k)^{-1}$ and $\beta_{\pi\pi k}(0)$ in front of the integral in eq. (16) and the form factor $e^{[\omega_{ijk} u/m_V^2]}$ within. The dependence of these quantities on the reggeon k is weak. That the coupling $\beta_{\pi\pi k}(0)$ could become sensitive to μ^2 (and possibly be very large) for $\alpha_k \leq 0$ is of academic interest, since such low-lying Regge poles do not occur in triple-Regge fits.

Let us now turn to the diagonal couplings and consider the dependence of g_{iik} on reggeon i.

$$g_{iik}(0) = \frac{3}{16\pi^3} \frac{1}{1+\alpha_k} \cdot \frac{1}{(2.5)} \beta_{\pi\pi i}^2(0) \beta_{\pi\pi k}(0) \times \int_{-\infty}^0 \frac{du}{(\mu^2 - u)^2} \times \left(\frac{\mu^2 - u}{m_V^2}\right)^{2\alpha_i} e^{[\omega_{iik} u/m_V^2]} \text{ mb} \quad (17)$$

where the $\mu^2 = 0$ limit of $(-u/(\mu^2 - u))^{1+\alpha_k}$ has been taken. If $i=P$ (with $\alpha_P=1$), the integral is independent of μ^2 and the scale is provided by m_V^2 :

$$g_{PPk}(0) = \frac{3}{16\pi^3} \frac{1}{2.5} \cdot \frac{1}{1+\alpha_k} \beta_{\pi\pi P}^2(0) \beta_{\pi\pi k}(0) \left(\frac{1}{m_V^2}\right) \frac{1}{\omega_{PPk}} \text{ mb} . \quad (18)$$

If $i=R$, with $\alpha_R=0.5$ we obtain

$$g_{RRk}(0) = \frac{3}{16\pi^3} \frac{1}{2.5} \frac{1}{1+\alpha_k} \cdot \beta_{\pi\pi R}^2 \beta_{\pi\pi k}(0) \left(\frac{1}{m_V^2}\right) \log\left(\frac{m_V^2}{\omega_{RRk}\mu^2}\right) \text{ mb} . \quad (19)$$

Notice how the physical value of μ^2 has entered in an essential way and how setting $\mu^2 = 0$ causes $g_{RRk}(0)$ to diverge (as anticipated by geometrical reasoning). The crucial difference between the inclusive cross sections discussed here and the total cross sections discussed in ref. [1] is that for the latter, μ^2 was expected to enter only for trajectories with $\alpha \lesssim 0$ (which do not feature in phenomenological Regge fits) while in the present case even the trajectories of intercept $\simeq 0.5$ (which are very much a part of triple-Regge fits) are μ^2 -dependent.†

For $R=P'$, if we recall that $\beta_{\pi\pi P}(0) \simeq \beta_{\pi\pi P'}(0)$ [2, 3] we obtain from eqs. (18, 19) the rough estimate:

$$\frac{g_{RRk}(0)}{g_{PPk}(0)} \sim \omega_{PPk} \left(\ln \frac{m_V^2}{\omega_{RRk} \mu^2} \right) \simeq 10 \quad (20)$$

for an average ω of 3.5 and $m_V^2/\mu^2 \simeq 50$.

Whether or not this ratio will be observed experimentally is decided by the corrections that must be applied to the model. The two key approximations made in the model were that:

(i) particle 4 in Fig. 1 is a pion, and that

(ii) granted (i), the amplitude is dominated by the pion pole in u .

It is not clear how approximation (ii) affects the ratio g_{RRk}/g_{PPk} . On the other hand the effect of the corrections to assumption (i) are easier to analyse, since even in which particle 4 is not a pion make additive corrections to the inclusive cross section and to the triple-Regge

† Whereas singular behavior of $g_{RRk}(0)$ in the $\mu^2 \rightarrow 0$ limit obtains only for $\alpha_R \leq 0.5$, a strong dependence on μ^2 is expected even if α_R were slightly above 0.5. We can see from eq. (17) that the dependence on μ^2 decreases smoothly with increasing α_i and ultimately disappears for $\alpha_i = \alpha_P = 1$.

couplings g_{ijk} calculated in the pion model. Let us consider for definiteness the impact of events in which particle 4 is a kaon, on the ratio g_{RRk}/g_{PPk} . If we assume for simplicity kaon pole dominance, the above calculations can be repeated* with $\mu^2 \rightarrow m_K^2$ and $\beta_{\pi\pi i}(0) \rightarrow \beta_{KKi}(0)$. The contributions to $g_{PPk}(0)$ will be of the same order as in the pion case since empirically $\beta_{\pi\pi i}(0) \simeq \beta_{KKi}(0)$, [2] and the meson mass drops out for such couplings. By contrast, the contributions to $g_{RRk}(0)$ will be much smaller than in the pion case due to the dependence of these couplings on the meson mass (eq. 20). A more detailed analysis suggests that the corrections to $g_{RRk}(0)$ will be of the same order as the corrections to $g_{PPk}(0)$. The net effect of the kaon events then, will be to lower the ratios $g_{RRk}(0)/g_{PPk}(0)$ calculated in the pion model.

That m_V and not the meson masses (μ or m_K) controls $g_{PPP}(0)$ is of theoretical interest for two reasons. First, the above circumstance lends credibility to the estimate of $g_{PPP}(0)$ by Abarbanel et al., [13] who assumed that an SU(3) octet of mesons contribute equally to $g_{PPP}(0)$. Had $g_{PPP}(0)$ a dependence on meson mass expected by geometrical reasoning, their assumption would have been grossly violated by the sizeable mass difference between the pions and the kaons within the octet. Secondly, and more importantly, a non-vanishing $g_{PPP}(0)$ of a scale decided by μ^2 would have led to an embarrassingly large value for the dimensionless parameter $\eta_P = \frac{S_0}{32\pi\alpha_P} g_{PPP}(0)$, which, according to these authors measures $1-\alpha_P$, the deviation of the pomeron intercept from unity. These features are not accidental, for consis-

* We are assuming that the form factors are the same in both cases for want of a more realistic alternative.

tency of the model requires that if the asymptotic total cross sections have a smooth limit as the meson mass vanishes, so must the triple-pomeron coupling $g_{PPP}(0)$.

Let us pause now to understand the physical origin of the factor $(\mu^2 - u)^{2\alpha_i}$ (eq. 17) which played a crucial role in the subsequent analysis.[†] Consider the schematic form of the amplitude for $pp \rightarrow p\pi X'$ in Fig. 2 along the t -channel. We see there a reggeon i of mass \sqrt{t} coupling to a π - π system consisting of a real pion of mass μ and a virtual pion of mass \sqrt{u} . We will discover that the factor $(\mu^2 - u)^{\alpha_i}$ corresponds to the usual threshold factor[‡] which inhibits the coupling of the π - π system to high spin reggeons i near the π - π threshold. Since μ is small and \sqrt{u} tends to be small (due to the pole factor $(\mu^2 - u)^{-2}$), the CM energy of the π - π system \sqrt{t} , is close to threshold if t is zero (as in our analysis) or small. The threshold factors are thus very effective and the coupling to the pomeron, which has the highest spin, is suppressed the most.

How did the threshold factor enter the coupling g_{iik} ? We know in the usual Regge analysis of $ab \rightarrow cd$ that the question of whether or not the residues exhibit threshold behavior is decided by the choice of the asymptotic variable. At high energies in the S -channel, if we expand the amplitude in terms of $\cos\theta_t = S/2pq$ (where p and q are the CM momenta of $a\bar{c}$ and $\bar{b}d$ respectively, in the t -channel), the contribution of a single Regge pole i is of the form

[†] Whereas the factor $((\mu^2 - u)/m_V^2)^{2\alpha_i}$ enters eq. (17), we will not go into the origin of $(m_V^2)^{-2\alpha_i}$ here, since the latter turns out to be a matter of simple algebra. The curious reader will be informed of its entry by means of a footnote.

[‡] This factor gets squared when we calculate g_{iik} .

$$M_i(S, t) \underset{t \text{ fixed}}{\underset{S \rightarrow \infty}{\overset{\sim}{\cos \theta_t}}} \xi_i(t) \gamma_{aci}(t) \left(\frac{S}{2pq}\right)^{\alpha_i(t)} \gamma_{bdi} \quad (21)$$

where $\gamma_{aci}(t) \underset{p \rightarrow 0}{\underset{S \rightarrow \infty}{\overset{\sim}{(p)}}}^{\alpha_i(t)}$ and $\gamma_{bdi}(t) \underset{q \rightarrow 0}{\underset{S \rightarrow \infty}{\overset{\sim}{(q)}}}^{\alpha_i(t)}$. If however, we expand in terms of (S/S_0) , as

$$M_i(S, t) \underset{t \text{ fixed}}{\underset{S \rightarrow \infty}{\overset{\sim}{(S/S_0)}}} \xi_i(t) \beta_{aci}(t) \left(\frac{S}{S_0}\right)^{\alpha_i(t)} \beta_{bdi}(t) \quad (22)$$

the "reduced" residues β will not exhibit strong threshold behavior.

Consider now the Regge expansion in the exclusive link carrying reggeon i (Fig. 2) which leads to the triple-Regge expansion of eq. (7).

To which of the two possibilities eqs. (21, 22) does it correspond?

Something inbetween, is the answer. To see why, note that for large M^2 ,

$$\sqrt{\frac{t-4m^2}{2}} \cos \theta_t = \sqrt{2p} \cos \theta_t \simeq \left(\frac{S}{M^2}\right) \times \sqrt{2t} \quad (23)$$

where m is the proton mass and p the CM momentum of the protons 1 and 3 (Fig. 2) in the t -channel. It follows that an expansion in the variable (S/M^2) corresponds to removing the threshold behavior only from the proton end and introducing an additional factor of $\sqrt{2t}$ into the missing mass end.[†] We may therefore anticipate in the coupling of reggeon i to X (that is, to the π - π system in our model) a factor $(\sqrt{2t} \cdot \sqrt{2q})^{\alpha_i(t)}$ and in $g_{iik}(0)$ a factor $(\sqrt{2t} \cdot \sqrt{2q})^{2\alpha_i}$, where q is the CM momentum of the π - π system in the t -channel. If we now recall

[†] Notice that in expanding in terms of (S/M^2) one also omits the Regge scale factor S_0 (compare with eq. (22)), which then gets absorbed into the missing mass end. The overall factor attached to this end is then $\sqrt{2t}/S_0 = \sqrt{2t}/m_V^2$. In the interest of clarity the factor $1/m_V^2$ is suppressed in these discussions.

that

$$2\sqrt{t}q = \lambda^{1/2}(t, u, \mu^2) = (\mu^2 - u) \quad \text{at } t=0, \quad (24)$$

we understand the origin of the factor $(\mu^2 - u)^{2\alpha_i}$ in $g_{iik}(0)$.[†]

We have restricted our discussions to the point $t=0$ so as to exploit the simple formula for $g_{ijk}(0)$. The numerical estimates for $g_{ijk}(t)$ given by Sorensen [9] indicate that the major features encountered at $t=0$ persist for modest values of $|t|$ (up to $\approx .25 \text{ GeV}^2$). As we move away from zero, the following considerations control the ratios $g_{RRR}(t)/g_{PPk}(t)$ and $G_{RRk}(t)/G_{PPk}(t)$:

(i) The threshold effects which discriminated between P and R will get weaker as we move in the negative t direction, since this takes us away from the π - π threshold. This will tend to lower the ratio $g_{RRk}(t)/g_{PPk}(t)$.

(ii) Due to the small slope of P, the difference $\alpha_P(t) - \alpha_R(t)$ increases with $|t|$ -- which in turn boosts the ratio $g_{RRk}(t)/g_{PPk}(t)$.

(iii) The residues $\beta_{\pi\pi P}(t)$ have a sharper t -falloff than $\beta_{\pi\pi R}(t)$, which enhances $g_{RRk}(t)/g_{PPk}(t)$. A similar consideration applies to $\beta_{ppP}(t)$ and $\beta_{ppR}(t)$ which tends to boost the ratio $G_{RRk}(t)/G_{PPk}(t)$ (see eq. (9)).

We will take these considerations into account when we put the model to a quantitative test in Section V. Let us now summarize our findings in somewhat more general terms. Consider $g_{ijk}(t)$ as the coupling of two reggeons i and j to the ends of a ladder k (Fig. 3). The ladder can contain any species of particles. Due to the choice of (S/M^2) as the asymptotic variable in eqs. (6, 7), the couplings of

[†] The triangle function $\lambda(x, y, z) = x^2 + y^2 + z^2 - 2xy - 2yz - 2zx$.

reggeons i and j to the edges of the ladder (that is, to the particles ab and ac respectively) contain threshold factors. The masses of a , b , and c insinuate themselves into $g_{ijk}(t)$ through these threshold factors and the propagators of band c . If the intercepts of the reggeons i and j are substantially above 0.5 (that is if $i=j$ =pomeron) these masses drop out. For trajectories R , of intercept ≈ 0.5 these masses enter the couplings and can play an important role. If these masses squared are commensurate with the scale factor of 1 GeV^2 (e. g., for kaons) their effect will be minimal. If, on the other hand, a , b , and c are pions (as in the model) the entry of the small pion mass μ into the couplings g_{RRk} will boost them up way above g_{PPk} . The consequent delay in the convergence of the series in the variable (S/M^2) may therefore be attributed to the new energy scale brought in by the pion mass, over and above S_0 .

V. Quantitative Comparison with Experiment

The object of this section is to compare the ratios of triple-Regge coefficients calculated within the model with experiment. The existing analyses omit off-diagonal coefficients G_{ijk} ($i \neq j$) in their fits -- either arbitrarily or on the basis of certain exchange degeneracy arguments.[7] In ref. [14] these exchange degeneracy arguments are criticized as being inapplicable in the triple-Regge region. It is pointed out there that according to the pion pole dominance model one of the off-diagonal terms (PRP) is expected to make a significant contribution (typically 30%) to the inclusive cross section. The fact that this possibly important term has been omitted in the data analysis makes a term by term comparison of the model with experiment pointless. We will therefore perform a comparison of average quantities, the sole purpose

of which will be to demonstrate that the ratios G_{RRk}/G_{PPk} given by the model are of the same order as the measured ones. Since there exists no unique prescription for the kind of average that must be employed, the following average ratio is chosen arbitrarily:

$$\frac{\langle G_{RRk} \rangle}{\langle G_{PPk} \rangle} = \frac{G_{RRR} + G_{RRP}}{G_{PPR} + G_{PPP}} \quad (25)$$

Since no measurement has been performed at $t=0$, the comparison will be made[†] at $t = -0.16 \text{ GeV}^2$. The comparison will be made only with fits that use the conventional trajectory $\alpha_R = 0.5+t$, since we can identify the latter with the P' and use its known residues and signature factor. The corresponding operation for the effective trajectory $\alpha_R = 0.2+t$ is ambiguous. To obtain $G_{iik}(t)$, eqs. (9) and (12) were combined, the residues of ref. [3] were used and the value of the complicated integral in eq. (12) extracted from Sorensen's paper. The results are given in Table II. It is encouraging to note that the difference between the model prediction for $\langle G_{RRk} \rangle / \langle G_{PPk} \rangle$ and the measured ones is no greater than the differences among the latter.

VI. Conclusions

We started with the surprising result of ref. [1] that in a multi-peripheral model the scale for the asymptotic cross sections is provided not by the mass μ of the exchanged pions but by m_V , the central mass of the low energy π - π resonance that entered the kernel -- a non-

[†] We wish to remain as close as possible to the point $t=0$, to which much of our discussion was confined. The choice of $|t| = 0.16 \text{ GeV}^2$ permits a comparison with refs. [5, 6, and 7].

geometric feature. Nevertheless, reconciliation with geometrical ideas was possible, since according to ref. [1], the μ^2 -independence was true for only the higher singularities ($\lambda \gtrsim 1/2$) while lower singularities were allowed to exhibit a dependence on μ^2 expected on geometrical grounds.

In this paper we tried to understand the role played by μ^2 in triple-Regge physics by considering the pion pole dominance model for triple-Regge couplings. We saw that of the three links carrying reggeons i , j and k (Fig. 2) the inclusive link (k) was controlled by m_V^2 and not μ^2 and for this reason had only a feeble dependence on α_k (provided α_k was well above zero). The situation in the exclusive links resembled in part that encountered in ref. [1] -- the higher reggeons were controlled just by m_V^2 , while the lower ones were controlled by μ^2 as well. The crucial feature here was that even the poles R of intercept 0.5, which play a prominent role in triple-Regge fits, were classified as low. The entry of the small pion mass into the couplings g_{RRk} was seen to boost them by a factor of about ten over the couplings g_{PPk} . The new mass scale introduced by the pion into g_{RRk} (and hence G_{RRk}) may then be viewed as the cause of the delayed convergence of the triple-Regge expansion in the variable (S/M^2) describing the exclusive links.

The tendency of the pion mass μ to enter the couplings via the pole factor $(\mu^2 - u)^{-2}$ and to boost them in magnitude due to its smallness; were offset either wholly (in $g_{PPk}(0)$) or in part (in $g_{RRk}(0)$) by the angular momentum barrier factors $(\mu^2 - u)^{2\alpha_i}$. It was pointed out that, had the model generated a non-vanishing $g_{PPP}(0)$ with a scale set by μ^2 rather than m_V^2 , an embarrassingly large η_P would have resulted.

The quantitative predictions of the model were compared with experiment. It was found that the ratio of averaged couplings,

$\langle G_{RRk} \rangle / \langle G_{PPk} \rangle$ given by the model was of the same order as the measured ones.

Acknowledgments

I acknowledge with great pleasure the patient and invaluable help of Geoffrey Chew, both in formulating the problem and in solving it.

Table I. Data in triple-Regge couplings $G_{ijk}(t)$ in mb GeV^{-2} .

Source	Trajectories	$ t (\text{GeV}^2)$	G_{PPP}	G_{PPR}	G_{RRP}	G_{RRR}
Ref. [4] (NAL)	$\alpha_P = 1$.33	.21	.87	33.7	30.4
	$\alpha_R = .5+t$.45	.14	.56	27.7	31.5
Ref. [5] (NAL)	$\alpha_P = 1+.25t$.16	1.3	3.8	108	--
	$\alpha_R = .2+t$ in RRP	.20	1.2	3.3	91	--
	$= .5+t$ in others	.25	1.0	2.3	78	--
	(fit III)	.33	.7	1.8	67	--
	$\alpha_P = 1+.25t$.16	.92	3.7	26	--
	$\alpha_R = .5+t$.20	.84	3.6	24	--
	$\pi\pi P$ included	.25	.75	2.3	23	--
	as per Ref. [10] (fit IV)	.33	.52	1.8	21	--
Ref. [6] (ISR) (The G's given in Ref. [4] have been multiplied by π to get the G's used by others.)	$\alpha_P = 1$.16	.83	--	15.7	--
	$\alpha_R = .5+t$.20	.70	--	15.7	--
		.25	.57	--	15.7	--
		.33	.41	--	15.7	--
	$\alpha_P = 1+.15t$.16	1.16	--	15.7	--
	$\alpha_R = .5+t$.20	1.0	--	15.7	--
		.25	.84	--	15.7	--
		.33	.65	--	15.7	--
Ref. [7]	$\alpha_P = 1+.25t$.16	2.6	1.6	96.3	86.2
	$\alpha_R = .2+t$.20	1.25	1.6	86.5	65.8
		.25	1.0	1.4	72.8	51.6
		.33	.75	1.2	54	37.8

Table II. Comparison of the pion-pole dominance model predictions for $G_{iik}(t)$ (in $\text{mb} \cdot \text{GeV}^{-2}$) with experiment, at $t = -0.16 \text{GeV}^2$.

Source	G_{PPP}	G_{PPR}	G_{RRP}	G_{RRR}	$\frac{\langle G_{RRk} \rangle}{\langle G_{PPk} \rangle}$
Ref. [5] fit IV	.92	3.7	26	--	11.3
Ref. [6] $\alpha_P(t) = 1$.83	--	15.7	--	18.9
Ref. [6] $\alpha_P(t) = 1 + \frac{1}{4}t$	1.16	--	15.7	--	13.5
Model	.38	.81	5.8	11	14.1

References

- [1] H. D. I. Abarbanel et al., Phys. Rev. Lett., 25 (1970), 1735.
- [2] V. Barger et al., Nucl. Phys. B5 (1968), 411.
- [3] V. Barger and R. J. N. Phillips, Phys. Rev., 187 (1969), 2210.
- [4] F. Sannes et al., Phys. Rev. Lett., 30 (1973), 766.
- [5] K. Abe et al., Phys. Rev. Lett., 31 (1973), 1527.
- [6] A. B. Kaidalov et al., Phys. Lett., 45B (1973), 493.
- [7] D. P. Roy and R. G. Roberts, Triple-Regge Analysis of $pp \rightarrow pX$ and Some Related Phenomenon -- A Detailed Study, Rutherford Lab Preprint, RL-74-022 (T79), January 1974.
- [8] H. D. I. Abarbanel et al., Annals of Phys., 73 (1972), 156.
- [9] C. Sorensen, Phys. Rev. D6 (1972), 2554.
- [10] M. Bishari, Phys. Lett., 38B (1972), 510.
- [11] R. Shankar, Nucl. Phys. B63 (1974), 168.
- [12] C. F. Chan and B. R. Webber, Phys. Rev. D5 (1972), 933.
- [13] H. D. I. Abarbanel et al., Phys. Rev. Lett. 26 (1971), 937.
- [14] Criticism of the $P' - \omega$ Exchange Degeneracy Arguments in the $pp \rightarrow pX$ Triple-Regge Region, R. Shankar, LBL-2678, March 1974. (Submitted to Physics Letters B).

Figure Captions

- Fig. 1. Rapidity plot of an exclusive event contributing to the inclusive cross section in the pion pole dominance model.
- Fig. 2. Schematic derivation of $g_{ijk}(t)$ in the pion pole dominance model.
- Fig. 3. The ladder description of the triple-Regge couplings. The dotted lines remind us that we are considering the absorptive part. The couplings γ have threshold factors while the couplings β do not.

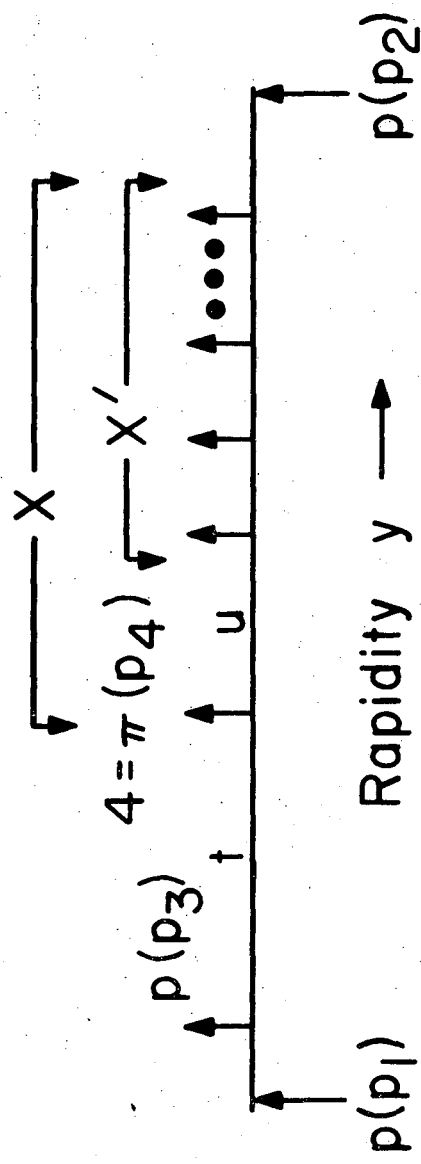

XBL 744-2818

Fig. 1

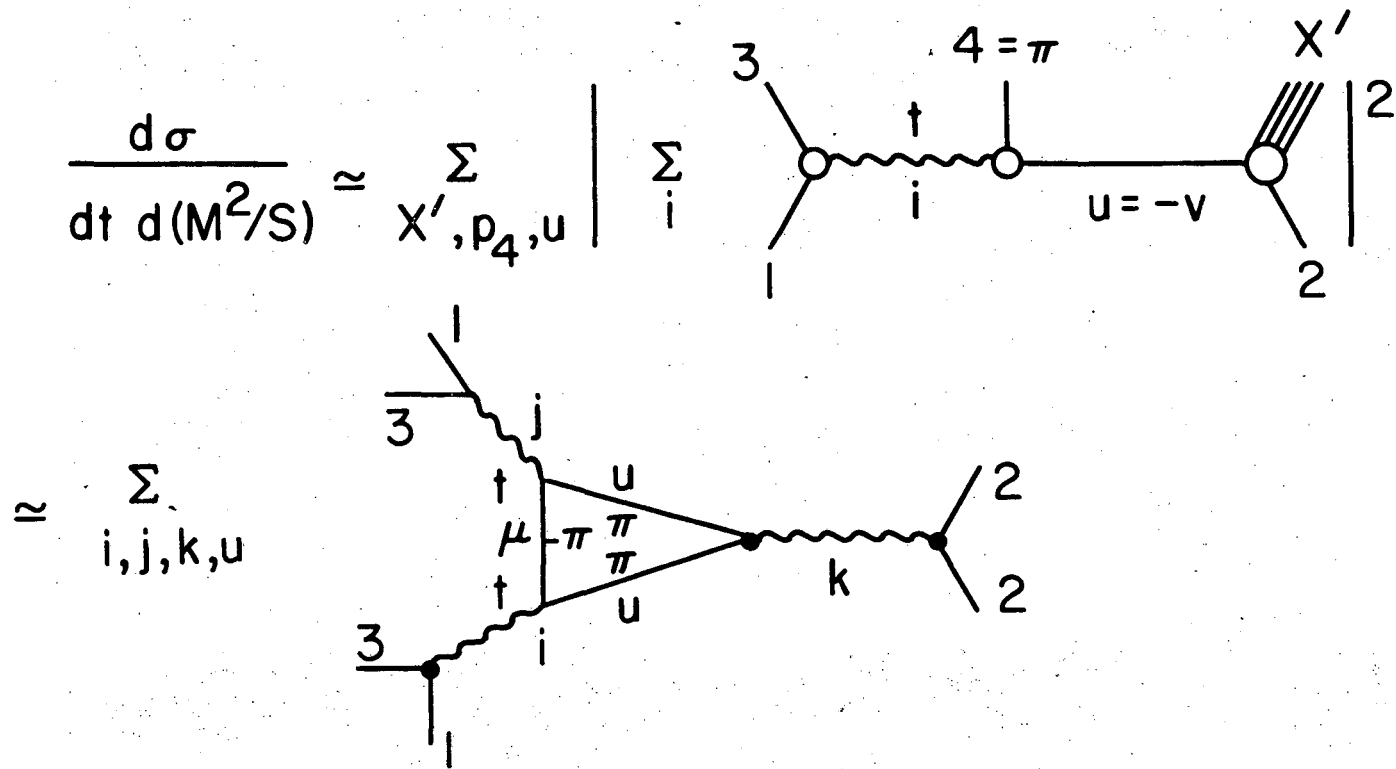
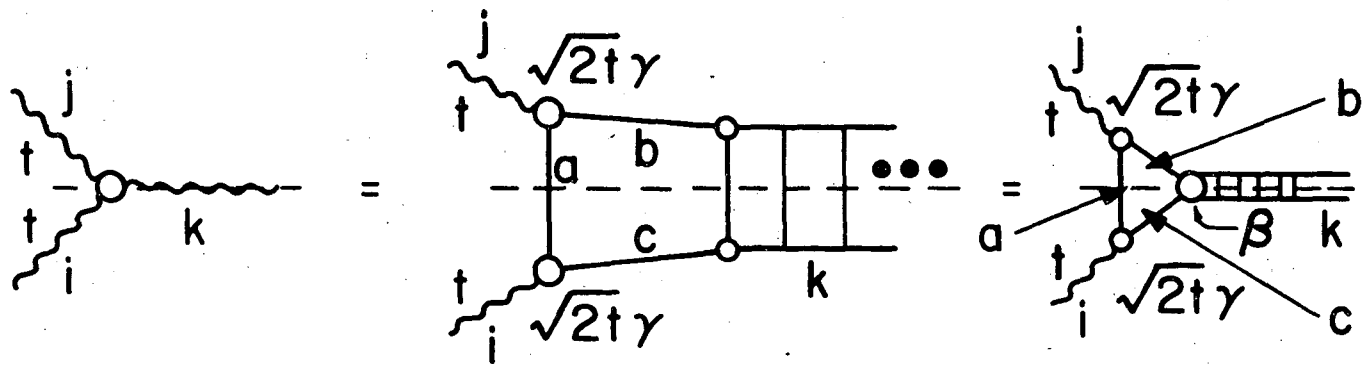

Fig. 2

XBL 744-2819



XBL 744-2820

Fig. 3

ACKNOWLEDGMENTS

It gives me great pleasure to acknowledge my deep sense of indebtedness to the following people: my parents, who taught me the art of living by example; my brother, R. Rajaraman, and my friend, Rajaram Nityananda, who introduced me to physics in their own ways; and Geoffrey Chew, who has been a generous friend and an inspiring teacher during my graduate years.

My warm thanks also go to my wonderful friends and teachers at Berkeley who made my stay both pleasant and instructive.

I am grateful to Ms. Christina Graham, Ms. Loretta Lizama, Ms. Deborah Olson and Ms. Georgella Perry for their kind help in the typing and preparation of the manuscript.

LEGAL NOTICE

This report was prepared as an account of work sponsored by the United States Government. Neither the United States nor the United States Atomic Energy Commission, nor any of their employees, nor any of their contractors, subcontractors, or their employees, makes any warranty, express or implied, or assumes any legal liability or responsibility for the accuracy, completeness or usefulness of any information, apparatus, product or process disclosed, or represents that its use would not infringe privately owned rights.

TECHNICAL INFORMATION DIVISION
LAWRENCE BERKELEY LABORATORY
UNIVERSITY OF CALIFORNIA
BERKELEY, CALIFORNIA 94720