

Lawrence Berkeley National Laboratory

Lawrence Berkeley National Laboratory

Title

The DFBX cryogenic distribution boxes for the LHC straight sections

Permalink

<https://escholarship.org/uc/item/99p7k04z>

Authors

Zbasnik, Jon P.
Corradi, Carol A.
Green, Michael A.
et al.

Publication Date

2002-07-05

The DFBX Cryogenic Distribution Boxes for the LHC Straight Sections

Zbasnik, J. P; Corradi, C. A; Green M. A; Kajiyama, Y; Knolls, M. J; LaMantia, R. F; Rasson, J. E; Reavill, D; and Turner, W. C.

Lawrence Berkley National Laboratory, Berkeley CA 94720, USA

The DFBX distribution boxes are designed to connect the LHC cryogenic distribution system to the interaction region quadrupoles [1] and dipoles for the Large Hadron Collider (LHC). The DFBX distribution boxes also have the current leads for the superconducting interaction region magnets and the LHC interaction region correction coils. The DFBX boxes also connect the magnet and cryogenic instrumentation to the CERN data collection system. The DFBX boxes serve as the cryogenic circulation center and the nerve center for four of the LHC straight sections. This report describes primarily the cryogenic function of the DFBXs.

THE FUNCTION OF THE DFBX

The DFBX boxes are part of the contribution from the United States to the Large Hadron Collider (LHC) at CERN. The US LHC machine contribution also includes the final focusing low beta quadrupoles [1] for LHC interaction regions (IR) 1, 2, 5 and 8 and superconducting dipoles on either side of IR 2 and 8. In IR 1 and 5, the superconducting dipoles are replaced with low field conventional dipoles from CERN. All four IRs have LHC superconducting corrector magnets, which are located within the low beta quadrupole string. The location of the DFBX within the left half of a LHC interaction region is illustrated in Figure 1. Figure 1 shows the location of the superconducting IR low beta quadrupoles, the IR correction magnets and the IR dipole (superconducting or conventional) with respect to the DFBX feed box.

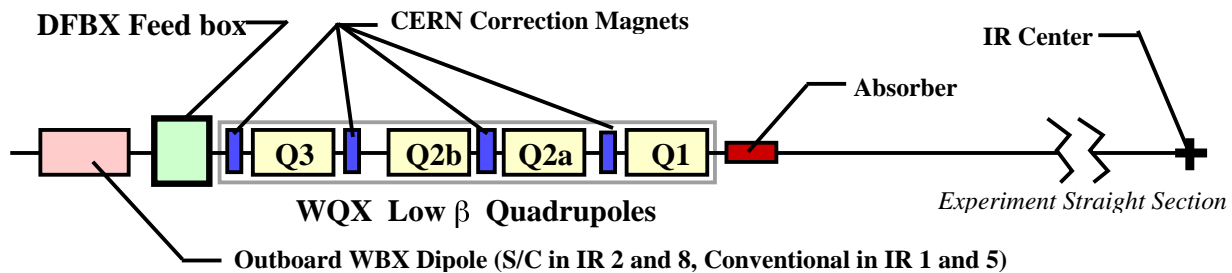

Figure 1 The Location of the DFBX with Respect to the Low Beta Quadrupoles, the Correctors, and the Outboard Dipole

Table 1 Parameters of the DFBX Feed Boxes for Various LHC Interaction Regions

IR Number	DFBX Boxes	Type of Dipole	# 7.5 kA Leads	# Other Leads	IR Slope
1	A and B	Conventional	4	24	+1.24%
2	C and D	Superconducting	6	24	+1.34%
5	E and F	Conventional	4	24	-1.24%
8	G and H	Superconducting	6	24	+0.42%

The DFBX connects the LHC helium cryogenic distribution system (the QRL) with the magnets. The cooling is supplied and returned to the LHC QRL distribution headers in four temperature ranges. 1.9 K cooling is supplied for the magnets. 4.4 K cooling is supplied for the magnet leads (both gas cooled and HTS leads) and busses. 20 K gas is used to cool from the top of the 7.5 kA high temperature superconductor (HTS) electrical leads and gas cooled leads to room temperature. Gas at 60 K cools the magnet and DFBX shields. In addition, the DFBX supplies cooling at 1.9 K to the LHC beam tube. The DFBX shares a common cryostat vacuum with the superconducting magnets on either side of the DFBX. A single LHC beam pipe that carries both beams passes through the middle of the DFBX.

In addition to being an integral part of the cryogenic system for the IR superconducting magnets, the DFBX also contains the electrical leads for all of the superconducting magnets around the DFBX [2]. As a result, the DFBX will have up to six 7.5 kA HTS leads, fourteen 600 A gas-cooled leads, and ten 120 A gas-cooled leads. (There are four HTS leads in the DFBX for straight sections 1 and 5, and there are six HTS leads for straight sections 2 and 8.) The final electrical function of the DFBX is to act as a conduit for the electrical signals from all of the superconducting magnets to the CERN control system. Figure 2 illustrates the various functions for a typical DFBX box in straight sections 2 and 8. Figure 3 shows a three dimensional representation of the feed box DFBX-G.

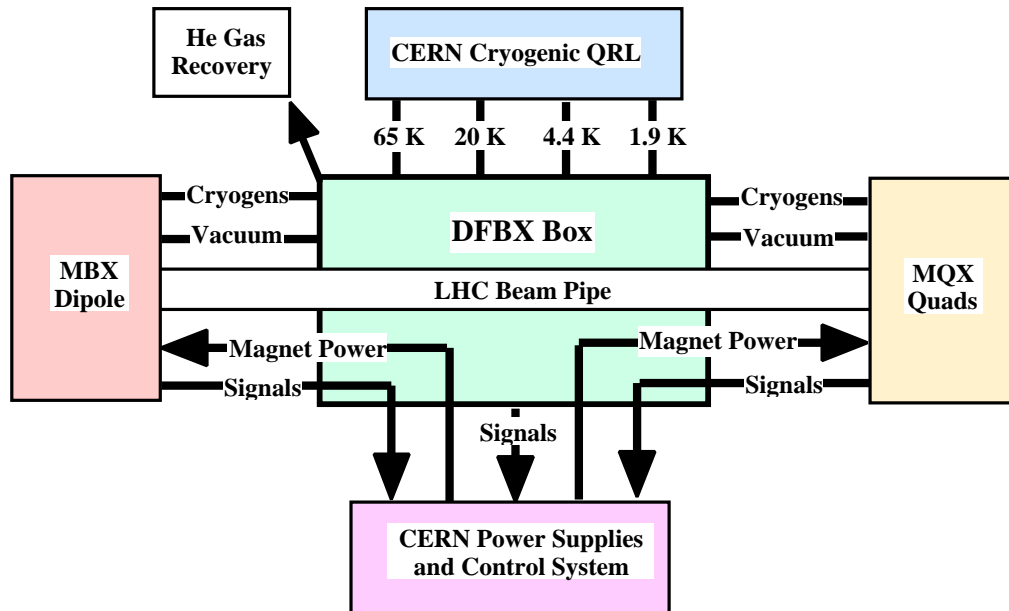

Figure 2. A functional Diagram for DFBX Boxes C, D, G and H around Interaction Regions 2 and 8. Interaction regions 1 and 5 have no MBX dipole magnet, but in all other ways these DFBX boxes have the same function as shown above.

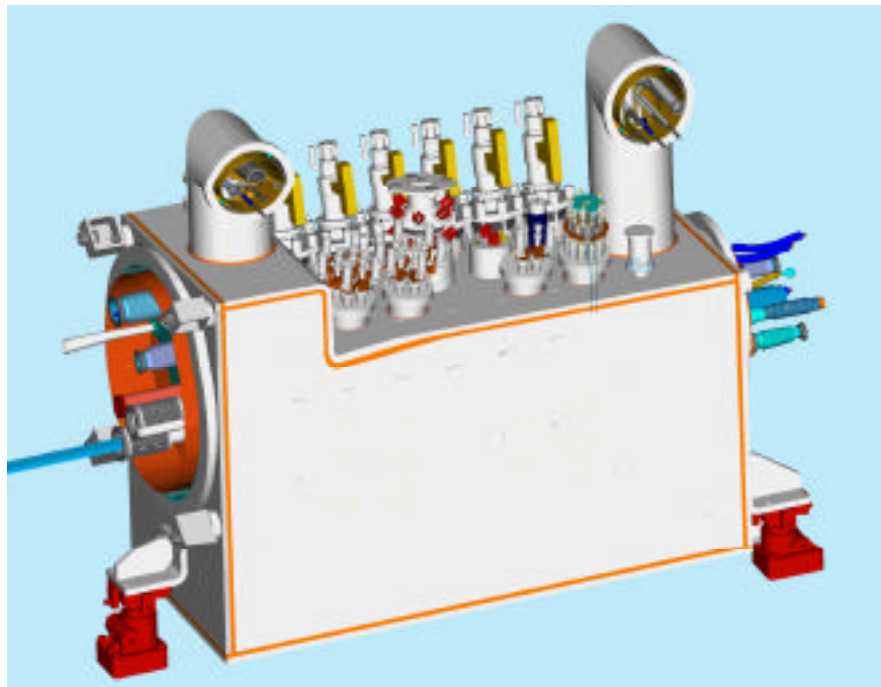

Figure 3 The LHC Cryogenic Distribution Box DFBX-G as seen from the CERN Cryogenic Supply Side. The LHC low beta quadrupoles are attached to the left at the WQX end; a superconducting dipole is attached to the right at the WBX end. The jumpers to the CERN QRL face the viewer. On top of the DFBX to the rear are the HTS leads in their chimneys. To the front are the gas-cooled lead chimneys and the instrumentation wire feed through for the magnets and cryogenic system.

DISTRIBUTION OF CRYOGENS THROUGH THE DFBX

Figure 4 is schematic representation of the flow of cryogenics from the CERN cryogenic supplies and returns (QRL) through the DFBX to the superconducting quadrupoles and correctors at the WQX end and the superconducting dipole at the WBX end. A single combined HTS and gas cooled lead combination represents all six of the 7.5 kA combined HTS and gas cooled leads. A single gas cooled lead in the diagram represents all of the 600 A and 120 A gas cooled leads. The top of the 7.5 kA HTS leads are cooled from a 20 K source of helium gas (line DH) that cools the upper (gas cooled) part of the leads. Flow control of this gas source is based on the voltage drop along the gas-cooled leads.

The current for the various magnets is carried from the DFBX to the magnets through the bus ducts MQX1 (for quadrupoles and the corrector magnets at the WQX end) and MBX1 (for the dipole at the WBX end). The bus ducts contain super-fluid helium at 1 bar. A low thermal-conductivity lambda-plug separates the super-fluid helium in the bus duct from the 4.4 K liquid helium in the DFBX helium tank. The leak rate through this plug must be low in order to keep super-fluid helium from flowing through the plug toward the 4.4 K region. The lambda plug carries the current busses from the bottom of the leads to the magnets. The 7.5 kA busses are made from Nb-Ti Rutherford cable. The 600 A and 120 A busses are made from a solid superconductor. Test lambda plugs built and tested at Lawrence Berkeley National Laboratory LBNL were vacuum tight even after being thermal shocked to 77 K over fifty times.

Figure 4 represents the most complicated piping diagram for the eight DFBX boxes. There are six variations of piping in the eight DFBX boxes. There is one piping assembly for each of the four boxes for straight sections 1 and 5 (the straight sections that don't have a superconducting dipole fed from the DFBX). Straight sections 2 and 8 have only a left to right variation for the piping in the DFBX (two of each kind). One reason for the DFBX piping complexity is that the LHC ring is not level. Straight sections 1 and 5 have a different slope from each other and from the slope of straight sections 2 and 8. The piping in the DFBX must be varied so that the liquid helium level in the magnets can be properly controlled. Four of the DFBX boxes have internal helium phase separation chambers that play a role in controlling two-phase helium flow through the DFBXs to the straight section dipoles and quadrupoles. Figure 5 shows a three-dimensional view of the piping for DFBX boxes C and G.

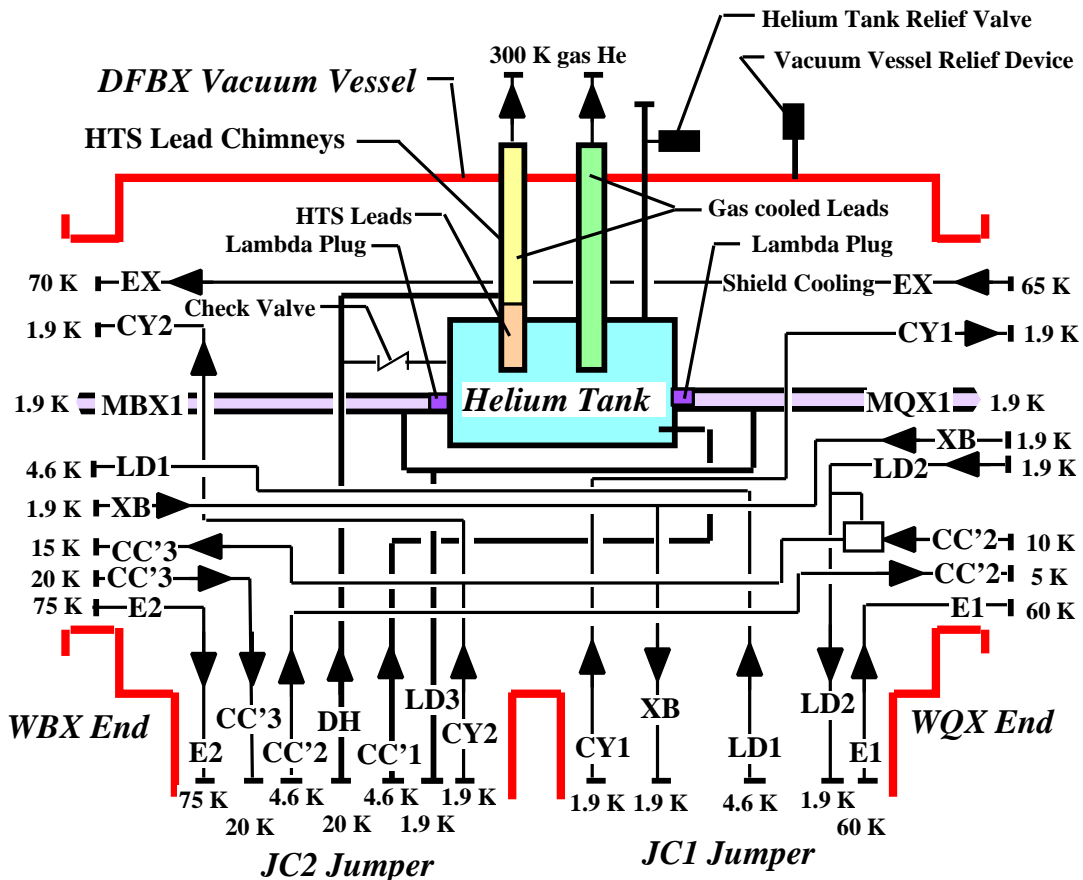

Figure 4. A Schematic Diagram for the Piping in DFBX Box G. (Note: The flow direction indicates flow during normal operation while the magnets on either side of the DFBX are cold. The temperatures shown in the diagram are approximate.)

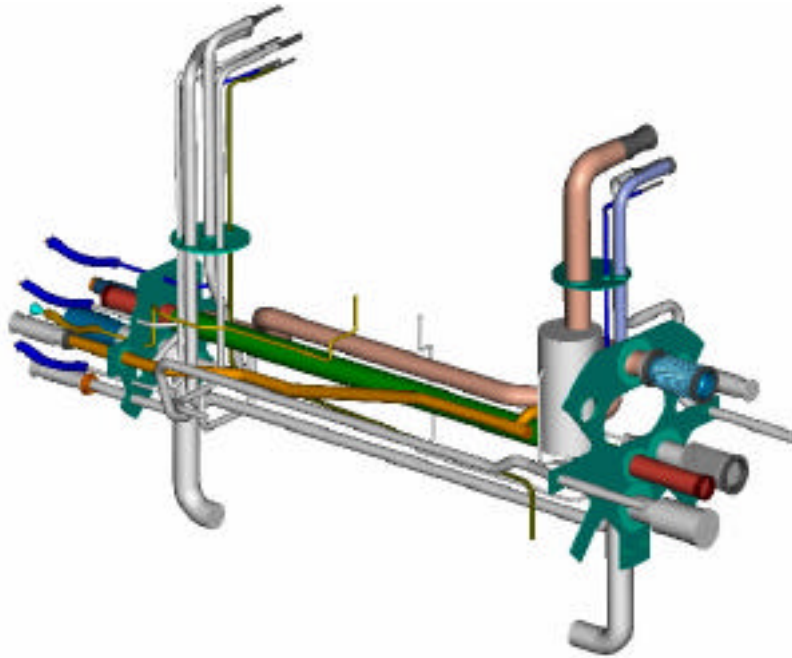

Figure 5. A View of the Piping for DFBXC and DFBXG Showing the Pipes that Connect the CERN Helium System to the Straight Section Quadrupoles and the Dipole. The WQX end is to the right; the WBX end is to the left. The pipes that go down and bend are the bus ducts for the magnet buses that go into the liquid helium tank. The straight red pipe is the LHC beam pipe. Its 1.9 K jacket is shown in green at the center of the figure. The piping to the QRL points away from the viewer.

The piping and helium tank within the DFBX boxes must be vacuum tight to a helium gas at the level of 10^{-10} Pa m⁻³ s⁻¹. The cryostat vacuum vessel and the parts of the helium tank assembly that see the atmosphere must be vacuum tight to helium gas at the level of 10^{-8} Pa m⁻³ s⁻¹. The DFBX cryostat insulation vacuum design value is less than 10^{-5} torr. The design heat leaks into the DFBX are as follows: For straight sections 1 and 5, the design heat loads are 396 W at 60 K, 91 W at 4.5 K and 9 W at 1.9 K. For straight sections 2 and 8, the design heat loads are 400 W at 60 K, 103 W at 4.5 K and 10 W at 1.9 K. (See Reference [3].) The cryostat standby heat loads are lower. The total design gas flow from the helium tank through the gas cooled corrector leads is about 0.5 g/s. The design 20 K helium mass flow for the gas cooled part of the 7.5 kA leads varies from 2.2 to 3.2 g/s depending in the straight section. The standby lead gas flows are lower.

CONCLUDING COMMENTS

The DFBX boxes act as the circulatory system and nerve center for the straight section quadrupoles on either side of interaction regions 1, 2, 5, and 8 of the LHC. These functions are extended to a cold dipole on either side of interaction regions 2 and 8. The DFBX contains a liquid helium tank that supplies cooling to the gas cooled correction coil leads and cools the bottom of the 7.5-kA HTS leads. The cooling for the upper end of 7.5-kA leads comes from 20 K helium gas fed into the region above the HTS leads from the QRL.

ACKNOWLEDGEMNT

This work was performed at the Lawrence Berkeley National Laboratory with the support of the Office of Science, United States Department of Energy under DOE contract number DE-AC03-76SF00098.

REFERENCES

1. Bossert, R et al, "Quench Behavior and Mechanical Behavior of the First Fermi-built High Gradient Quadrupole for the LHC Interaction Region," to be published in IEEE Transactions on Applied Superconductivity 12, No. 1 (2002)
2. J.P. Zbasnik et al, "DFBX Boxes – Electrical and Cryogenic Distribution Boxes for the Superconducting Magnets in the LHC Straight Sections," to be published in IEEE Transactions on Applied Superconductivity 13, No. 2 (2003)
3. Zbasnik J. "Functional Specification, Inner Triplet Feedboxes, DFBX," CERN Document LHC-DFBX-ES100.00 (2000)

DISCLAIMER

This document was prepared as an account of work sponsored by the United States Government.

While this document is believed to contain correct information, neither the United States Government nor any agency thereof, nor The Regents of the University of California, nor any of their employees, makes any warranty, express or implied, or assumes any legal responsibility for the accuracy, completeness, or usefulness of any information, apparatus, product, or process disclosed, or represents that its use would not infringe privately owned rights. Reference herein to any specific commercial product, process, or service by its trade name, trademark, manufacturer, or otherwise, does not necessarily constitute or imply its endorsement, recommendation, or favoring by the United States Government or any agency thereof, or The Regents of the University of California. The views and opinions of authors expressed herein do not necessarily state or reflect those of the United States Government or any agency thereof, or The Regents of the University of California.

Ernest Orlando Lawrence Berkeley National Laboratory is an equal opportunity employer.