

Lawrence Berkeley National Laboratory

LBL Publications

Title

Analysis of curtailment at The Geysers geothermal Field, California

Permalink

<https://escholarship.org/uc/item/9b8682xq>

Authors

Dobson, Patrick

Dwivedi, Dipankar

Millstein, Dev

et al.

Publication Date

2020-09-01

DOI

10.1016/j.geothermics.2020.101871

Peer reviewed



ELSEVIER

Contents lists available at ScienceDirect

Geothermics

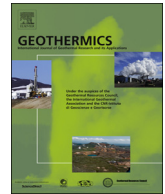
journal homepage: www.elsevier.com/locate/geothermics

Analysis of curtailment at The Geysers geothermal Field, California

Patrick Dobson^{a,*}, Dipankar Dwivedi^a, Dev Millstein^b, Nandini Krishnaswamy^c, Julio Garcia^d,
Mariam Kiran^e^a Energy Geosciences Division, Lawrence Berkeley National Laboratory, Berkeley, CA, 94720, USA^b Energy Analysis & Environmental Impacts Division, Lawrence Berkeley National Laboratory, Berkeley, CA, 94720, USA^c Computational Research Division, Lawrence Berkeley National Laboratory, Berkeley, CA, 94720, USA^d Calpine Corporation, Middletown, CA, 95461, USA^e Scientific Networking Division, Lawrence Berkeley National Laboratory, Berkeley, CA, 94720, USA

ARTICLE INFO

Keywords:

Geothermal power generation

Curtailment

Flexible generation

Renewables portfolio standard (RPS)

ABSTRACT

Geothermal energy has traditionally been viewed as a baseload energy source, but the rapid growth of intermittent renewable energy has led to a need for more flexibility in power generation to avoid mandatory curtailment imposed by grid operators. This study of curtailment at The Geysers provides insights into the magnitude, duration, frequency, temporal and spatial distribution, and potential causes of curtailment events between 2013 and 2018. Annual levels of curtailment range during this period from 9 to 47 GW h, representing 0.15 to 0.81 % of the net generation. Most curtailments occurred at the power plants connected to a lower capacity transmission line and may result from transmission constriction. There is a clear link between negative pricing and economic curtailment, especially when solar production is higher. Economic curtailment events tend to be only a few hours and vary in magnitude up to almost 300 MW, whereas transmission-related curtailment events can be up to several weeks in duration. It is likely that curtailment of geothermal power will be an increasing concern, and could be mitigated by flexible generation strategies and increases in energy storage. It is critical to know the nature of curtailment events so that flexible generation options can be assessed properly.

1. Introduction

Geothermal power generation has traditionally been viewed as a baseload energy resource, with 24/7 availability and high capacity factors. However, there is increased value for dispatchable generation to help fill in daily and seasonal changes in power requirements. As part of the U.S. Department of Energy's (DOE) Grid Modernization Initiative (GMI), the DOE's Geothermal Technologies Office has embarked on a Beyond Batteries initiative to support research relating to opportunities for integrating geothermal energy into flexible generation, controllable loads, and new approaches to the broader concept of energy storage and to identify ways to utilize geothermal resources when power generation is curtailed. To do this, it is critical to understand what factors govern curtailment, as they will influence what other resource utilization options are feasible. The Geysers geothermal field (subsequently referred to as The Geysers) was selected as a case study to examine this issue for a number of reasons: 1) it is the world's largest geothermal field, and has an operating history of almost 60 years; 2) there are abundant operational data sets available that are needed to conduct

such a study; and 3) The Geysers has an extended history of curtailment events that make it an ideal candidate for this analysis. This study examines historical records of curtailment at The Geysers geothermal field to evaluate when it occurs, how long it lasts, how much power is curtailed, and what are the driving forces behind curtailment. This effort will also investigate recent diurnal and seasonal patterns in hourly nodal wholesale electricity prices near The Geysers, whether they align with periods of curtailment, and how The Geysers has adapted its operations based on these price patterns.

Periodic curtailment of geothermal power production has occurred at The Geysers geothermal field in California since the 1980s (Cooley, 1996; Barker and Pingol, 1997; Goyal, 2002; Matek, 2015), based on variability in demand and availability of lower cost power options, with variability of total renewable energy curtailment occurring on a daily and seasonal basis. With the large growth of intermittent energy sources such as solar and wind in California, in part due to the regulatory requirements of renewable portfolio standards and the declining costs of these energy sources, there are regular curtailments of geothermal power production by the California Independent System Operator

* Corresponding author.

E-mail addresses: pfdobson@lbl.gov (P. Dobson), ddwivedi@lbl.gov (D. Dwivedi), DMillstein@lbl.gov (D. Millstein), nkrishnaswamy@lbl.gov (N. Krishnaswamy), julio.garcia@calpine.com (J. Garcia), mkiran@es.net (M. Kiran).<https://doi.org/10.1016/j.geothermics.2020.101871>

Received 1 January 2020; Received in revised form 4 April 2020; Accepted 26 April 2020

0375-6505/ © 2020 Lawrence Berkeley National Laboratory (manual version of copyright notice completed and submitted). Published by Elsevier Ltd. This is an open access article under the CC BY-NC-ND license (<http://creativecommons.org/licenses/by-nc-nd/4.0/>).

(CAISO), particularly at times of negative wholesale power prices brought on by low net-demand (e.g., high levels of solar power generation and relatively low load in the middle of the day during Spring). If exposed to wholesale market prices (rather than selling through a power-purchase agreement (PPA) at fixed price levels), geothermal operators will typically reduce power production to avoid negative pricing by reducing steam flow from production wells. These reductions in flow may help sustain long-term generation by reducing reservoir depletion (e.g., Goyal, 2002), but may have deleterious effects on the wells caused by thermal cycling of the wellbores (e.g., Rutqvist et al., 2018, 2020). In addition, the changed wholesale price environment results in decreased revenues, making operation of the geothermal resource less profitable, thus discouraging future development of other geothermal systems. In order to identify what kinds of alternative utilization of geothermal energy could be developed to alleviate this problem, it is critical to understand the magnitude and frequency of these periods of curtailment, and the forces that drive this process.

2. Historical curtailment at The Geysers

The Geysers geothermal field is located in northern California, and is currently the largest producing geothermal field in the world (Fig. 1). It has been in operation since 1960, with peak output of ~1.6 GWe in 1987 (Sanyal and Enezy, 2016); current production levels for the entire field are around 750–800 MWe. Geothermal fields have been traditionally operated as baseload facilities, typically resulting in high capacity factors for the power plants. Prior to deregulation of the electrical power market in California, there was separate ownership of the steam fields and the power plants at The Geysers. Initially, the geothermal power plants at The Geysers were operated as a source of baseload power, but following a change to the steam supply agreement in 1994, Pacific Gas & Electric (PG&E) was allowed to operate 12 of its geothermal power plants under dispatch mode. This meant that when either cheaper sources of power were available (such as hydro or natural gas), or power demand was low, they could curtail the delivery of steam to the power plants (Cooley, 1996). Under the terms of this agreement, PG&E had to maintain at least a 25 % capacity factor on a monthly basis and a 40 % capacity factor on an annual basis. The most extreme curtailment occurred in 1995, when almost 2 TWh of geothermal power production was deferred at The Geysers (Cooley, 1996); a similar magnitude economic curtailment occurred the following year (Barker and Pingol, 1997). Heavy winter rains (resulting in abundant

cheap hydro power) and low natural gas prices were in part responsible for these two years of major curtailments (Fig. 2); they resulted in reduced revenues on the part of the geothermal steam field operators, who were partly compensated by a monthly curtailment fee under the terms of the steam supply agreement (Cooley, 1996). The neighboring Northern California Power Agency (NCPA) power plants also operated in a load-following mode during these years, with much lower nighttime generation levels (Matek, 2015). As part of the deregulation of the electrical power market in California, PG&E divested itself of its 12 power plants at The Geysers, which were purchased by Calpine (the primary steam field operator) in 1999.

Apart from the economic impacts associated with curtailment, the field operators were also concerned with potential impacts to the geothermal reservoir and well field. Some of the potential impacts that were considered included thermal cycling of the wells, which could lead to damage of the well casing and cement, bridging (localized borehole collapse) of wells that have reduced flow or that are shut in, increased condensation in the steam-gathering system that could lead to corrosion, performance issues with valves and cooling towers, and increases in non-condensable gases that could result in gas emissions exceeding regulatory limits (Cooley, 1996; Barker and Pingol, 1997). One benefit to curtailment that was observed was that the overall production decline trend of the field was reduced, and that a short-term increase (or “puff”) in production occurred subsequent to curtailment events. An analysis of curtailments (ranging from steam production reductions of 9–32 % and lasting from 2 to 7 weeks in duration) that occurred in the Calistoga and Bear Canyon well fields in 2001 showed that these areas experienced short-term increases in production, but only about 15 % of the curtailed production was later recovered as a result of these “puffs” (Goyal, 2002). Transmission curtailments caused by work on an associated substation in 2005 and 2006 also appear to have resulted in small short-term upticks in production following the curtailment events (Stark et al., 2005; Goyal and Conant, 2010).

3. Changes in the California power market and their impacts on geothermal power production

Deregulation of the California electricity market has had a significant impact on The Geysers geothermal field, resulting in consolidation of both steam field and power plant operations. This has enabled the field and plant operators to more fully integrate power plant and steam field operations, leading to improved performance

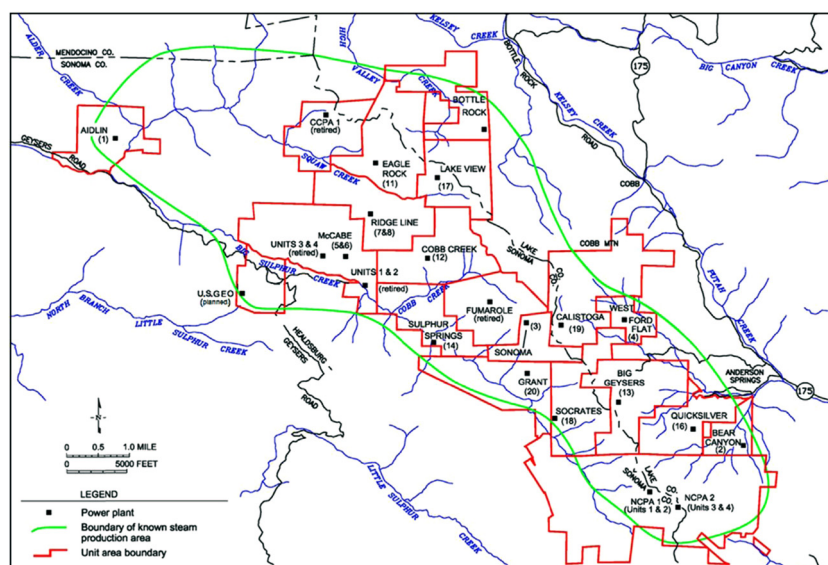

Fig. 1. Map of the location of power plants and associated unit areas at The Geysers. Calpine operates all but three of the power plants (NCPA 1, NCPA 2, and Bottle Rock) in the field. Figure from Sanyal and Enezy (2016).

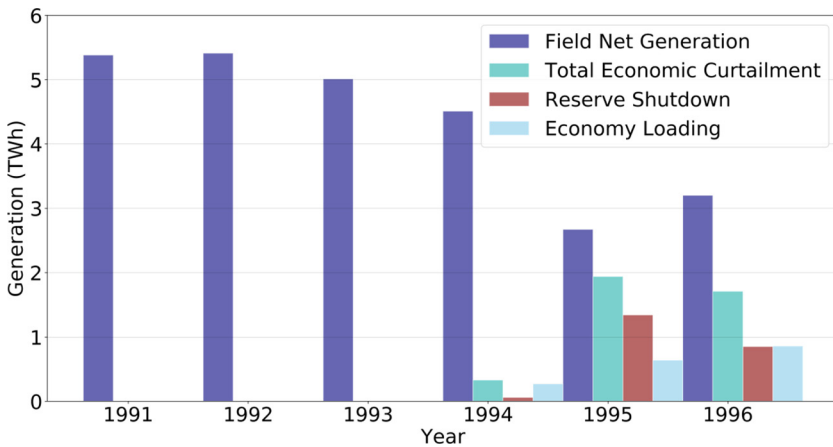

Fig. 2. Annual net generation and economic curtailment for the Union-NEC-Thermal portion of The Geysers geothermal field from 1991 to 1996. Reserve shutdown corresponds to plants that were shut down due to curtailment, while economy loading refers to plants with reduced load operations resulting from curtailment. Figure from Barker and Pingol (1997).

(Goyal and Conant, 2010). Several other major changes have occurred in the California power market that have impacted geothermal power generation. The first of these changes was the implementation of California's Renewables Portfolio Standard (RPS) in 2002 under California Senate Bill 1078. The passage of California Senate Bill 107 accelerated the renewable energy requirements in 2006 by requiring that 20 percent of electricity retail sales be served by renewable energy resources by 2010. In April 2011, California Senate Bill X1 – 2 reset the RPS target to 20 % by the end of 2013, 25 % by the end of 2016, and 33 % by the end of 2020. A more ambitious RPS was passed in October 2015 (California Senate Bill 350), requiring retail sellers and publicly owned utilities to procure one-half of their electricity from eligible renewable energy resources (e.g., solar, wind, geothermal, small scale hydro, biomass) by 2030. In 2018, California Senate Bill 100 established new targets of 60 % of electricity generation from renewable resources by 2030 and 100 % generation of electricity from zero-carbon sources by 2045. Another major change (in part resulting from the implementation of these renewable energy requirements) was the surge in intermittent renewable power generation in California resulting from major capacity increases in PV solar and wind generation - these changes were also accelerated by the dramatic drop in cost for these energy sources.

The rapid growth in intermittent renewable energy generation in California has led to the need for rapid increases and decreases in power production driven by changes in supply and demand throughout the day, as reflected by the “duck curve”, a graph of daily power production that shows the timing imbalance between peak demand and renewable energy production,

where oversupply driven by solar power production can lead to negative pricing (Fig. 3). Within the California market, curtailment can

occur for a number of reasons, including excess generation during low load periods, transmission congestion or lack of transmission access, or voltage and interconnection issues (Golden and Paulos, 2015). Possible ways to mitigate overgeneration and curtailment include automatic generation control to adjust power output in response to real-time load changes, negative pricing, the energy imbalance market, where a more regional market can better adjust to local variations in generation and load, and increased energy storage capacity. Additional steps that could also be taken to reduce curtailment include a more diversified renewable energy portfolio, enhanced coordination between regions, increased flexibility in the load, and more flexible generation (Golden and Paulos, 2015).

Economic curtailments of solar and wind have generally increased over the past few years in California, with changes occurring both seasonally and annually (Fig. 4). About 1% of the total renewable energy generation was curtailed during the first quarter of 2017; the bulk of this curtailment was associated with wind and solar. Short-term (hourly) curtailments of solar were at times in excess of 30 % (CAISO, 2017).

Load Serving Entities (LSEs) within the jurisdiction of the California Public Utilities Commission (CPUC) (including investor-owned utilities, energy service providers, and community-choice aggregators) are obligated as part of the state’s resource adequacy policy to contract with power generation facilities to meet expected loads plus a 15 % reserve (Woo et al., 2016) - this also includes a flexible requirement to cover the largest three hour ramp for each month needed to run the system reliably. The resource adequacy requirement is critical to providing the generation capacity that is needed for a power market with a large (and growing) fraction of intermittent renewable resources (solar and wind),

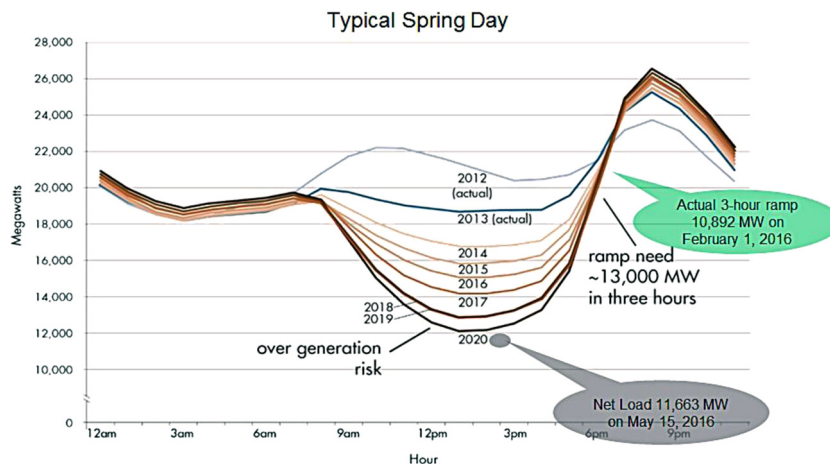

Fig. 3. Scenarios of daily net load curves for California “Duck curve” (CAISO, 2016).

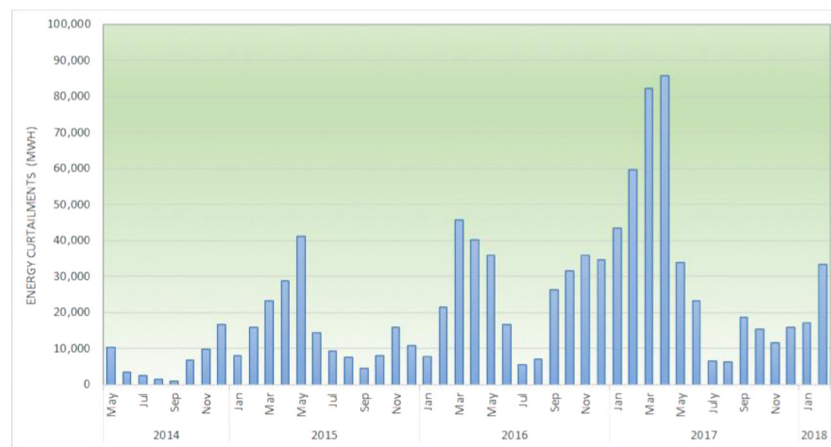

Fig. 4. Curtailment of solar and wind energy production in California from 2014-2018. Figure from CAISO presentation, March 14, 2018 (CAISO, 2018).

and providing incentives for developing new power generation facilities within the state. These changes have all led to a need for more flexible power generation and increased energy storage.

There is a precedent for flexible operation of geothermal fields - the Puna geothermal field in Hawaii employs a turbine bypass system that allows the operators to provide dispatchable (rather than baseload) power to the local utility (Nordquist et al., 2013). Several studies have evaluated the viability of flexible generation for geothermal facilities, and have noted that flexible generation could provide additional ancillary services to the grid that should be recognized and valued, such as system frequency regulation, load following, and the ability to ramp up and down capacity quickly (e.g., Edmunds and Sotorrio, 2015; Matek, 2015). Flexible generation could also lead to avoided costs associated with additional generation, transmission, and distribution systems that would be needed with a more rigid generation system. Hernandez et al. (2017) suggested that if proper financial incentives are provided to geothermal power plant operators to help meet the growing need for ramping demand for the California electrical market, it could be financially viable to operate under a flexible mode scenario; another option would be to develop another use for the excess steam during periods of curtailment.

The California Energy Commission (CEC) has funded two studies at The Geysers to evaluate the feasibility of operating the field to respond to flexible demand conditions. Calpine, the primary operator at The Geysers, studied how their operations could be modified to accommodate load-following power production (Urbank and Jorgensen, 2016).

This analysis included developing integrated models to simulate the effects of flexible generation on the reservoir, wells, pipeline, and power plants, with data to validate these models obtained from pilot tests on individual components. Some of the risks that have been identified include corrosion and scaling within wellbore casing and pipelines, wellbore damage from formation collapse, formation of condensate during low flow conditions that could lead to corrosion, and the buildup of non-condensable gases. Other aspects of this study involved testing of upgraded electric actuators that control well flow, improved flow meters, development of an automated scrub water flow system that would adjust to changes in steam flow, and the potential development of turbine bypass capability. Turbine bypasses designed for continuous operation were installed and tested on Unit 5 (McCabe) (direct contact condenser) and 17 Unit (Lakeview) (surface condenser). Both turbine bypasses were able to divert steam to the condenser and achieve zero net MW while maintaining near steady-state conditions in the steam field. Other features being studied by Calpine under this flexible generation scenario include makeup water and H₂S abatement systems (additional details of these systems are presented in Section 7). A second CEC-funded study employs coupled process modeling to

evaluate the potential impacts that flexible power production might have on the well field. Repeated thermal cycling caused by variations in flow rates can have detrimental effects on mechanical well (cement and casing) integrity (Rutqvist et al., 2018, 2020).

4. Curtailment and impacts on operations at The Geysers

Two types of curtailment typically occur at The Geysers: curtailment due to transmission congestion, and economic curtailment resulting from negative pricing. The power plants at The Geysers are connected to three different transmission lines (Fig. 5). When congestion curtailment occurs, power plants that are connected to the same transmission line are generally impacted as a group. Congestion curtailment can occur when a transmission line or its associated substation is out of service for repair; it can also be driven by overgeneration commitments from CAISO. Most of the transmission congestion occurs on the smaller 115 KV transmission lines associated with the Eagle Rock Substation, and rarely occurs system-wide.

The other type of curtailment is caused by economic factors, which are driven by systemwide overproduction that leads to negative pricing. The California Independent System Operator (CAISO) issues dispatch requests to power plant operators for incremental generation (INCs), or increased generation levels, and decremental (DECs), or reduced generation levels, at 5-minute intervals. Because the Calpine power plants at The Geysers operate on a Valves Wide Open (VWO) mode, they only respond to DECs requests. DECs in spring months are generally related to higher hydro generation, especially in years with higher snowpack (CAISO, 2017). Increased solar generation can also trigger requests for DECs throughout the year.

When and how much curtailment occurs at The Geysers depends on a number of factors, which include:

- The Geysers responds to negative pricing DECs based on Calpine bid curves for day ahead and real time. Run schedules are provided to CAISO based on expected generation levels (these can vary based on whether there may be local outages, changing atmospheric conditions that can affect power plant efficiencies, etc.). The generation profile is not adjusted based on real-time pricing.
- The majority of power generation at The Geysers is contracted - Calpine is paid for power generation via power purchase agreements with utility companies (e.g., PG&E) or community choice aggregates (e.g., Marin Clean Energy).
- Calpine receives Renewable Energy Credits (RECs) for generating green power - however, these payments are only received for power that is generated. Calpine will continue to generate power even under negative pricing until the price falls below the REC value.
- Calpine also has some Resource Adequacy (RA) commitments that

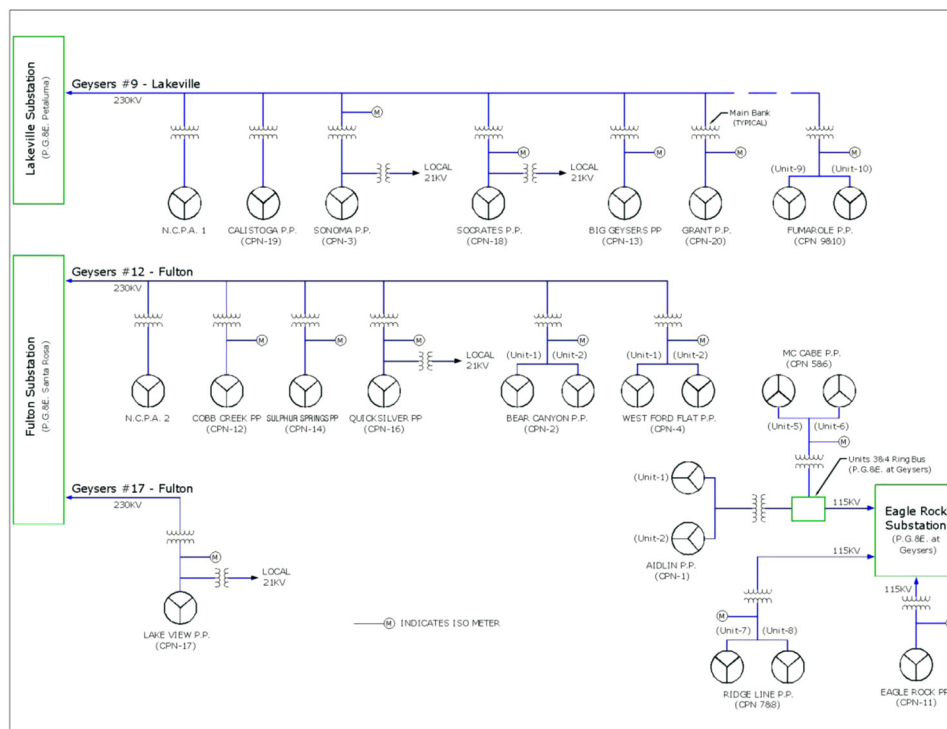

Fig. 5. Configuration of geothermal power plants at The Geysers to the transmission system. There are three substations (Lakeville, Fulton, and Eagle Rock); the power plants associated with the Eagle Rock substation have a 115 KV transmission line, while the other transmission lines are 230 KV.

help ensure that LSEs provide sufficient resources to the California Independent System Operator to ensure the safe and reliable operation of the grid both now and in the future.

- Negative pricing DEC-driven curtailments are typically short in duration. Calpine is currently able to curtail approximately 350 MW of power production for about 4–5 hours without violating well and steam field constraints - these limits can be higher with the use of the turbine bypass systems that were recently installed for two of the power plants at The Geysers.

Wildfires have also had a significant impact on power generation operations at The Geysers. Over the past five years, there have been three major wildfires that have affected power operations either through direct physical damage of power plant facilities, restricting access to the site, or by damaging transmission facilities. The Sept. 2015 Valley Fire (CAL FIRE, 2015) completely destroyed the cooling towers at four of Calpine’s power plants (West Ford Flat, Unit 16, Unit 18, and Unit 20), and destroyed one set of cooling towers at a fifth plant (Sonoma). The fire also damaged much of Calpine’s automated well valve control system, as well as the power lines to the Bear Canyon pump station for the Southeast Geysers effluent pipeline, which is used to help recharge the reservoir (Dellinger, 2016). However, the unaffected power plants continued to operate throughout the wildfire, and the field was back operating at about ¾ of its normal production levels within a week (Geothermal Resources Council, 2015). The Tubbs Fire, which occurred in Oct. 2017, burned a large swath of terrain south of The Geysers geothermal field, impacting access to the field. Most recently, the 2019 Kincade fire caused minor impacts on field operations at The Geysers, but damaged the transmission line that powers the pumping stations that deliver treated water from Santa Rosa used to supplement reinjection (Schmitt, 2020). However, the wildfires are not considered further in this evaluation of curtailment.

Electrical power market and transmission factors were considered in this analysis of power curtailment at The Geysers. An examination of Calpine’s curtailment records from the past six years at The Geysers was conducted to better understand the timing, frequency, duration,

magnitude, and location of curtailment events, with the goal of evaluating how these factors have affected the recent history of curtailment.

5. Analysis of curtailment at The Geysers: 2013–2018

This analysis is based upon two major sources of data - hourly curtailment records from each power plant at The Geysers that were supplied by Calpine, and nodal hourly price data from CAISO that are linked to each power plant for the years 2013–2018. Hourly curtailment values were calculated using an approximation of the MW reduction that Calpine was asked to execute from the actual MW generating at the time of the CAISO request. The analysis involves all of Calpine’s power plants at The Geysers: Table 1 lists the power plant unit, nameplate capacity, price node ID obtained using ABB Velocity Suite (ABB Enterprise Software, 2017), and the associated transmission substation. ABB Velocity Suite collects data from many industry and government sources, harmonizes the data, and provides users access to this data. The nodal pricing data is collected directly from the relevant independent system operators, in this case, from the California Independent System Operator (CAISO).

These detailed curtailment records were evaluated using a number of analytical and statistical tools to evaluate the following curtailment patterns.

5.1. Amounts and changes in the overall curtailment per year

The annual curtailment between the years 2013–2018 has varied by over a factor of four (Fig. 6). The lowest level of curtailment in this period occurred in 2013 (with a total curtailment ~9 GW h), followed by a large jump in 2014 to a value exceeding 47 GW h. The following three years had curtailments of around 30–34 GW h, and 2018 had nearly a 50 % drop in curtailment to ~17 GW h; part of this recent drop may have resulted from exporting excess solar power through the California ISO’s Western Energy Imbalance Market. Annual net generation for the Calpine portion of The Geysers was 6003 GW h in 2013, 5836 GW h in 2014, 5559 GW h in 2015, 5554 GW h in 2016, and

Table 1
Calpine Power Plant Units at The Geysers.

Unit name	Nameplate capacity (MW) ¹	Corresponding CAISO Nodal ID	Transmission substation
5 & 6 (McCabe)	110	1158245, 1158246	Eagle Rock
7 & 8 (Ridge Line)	110	1158397, 1158398	Eagle Rock
11 (Eagle Rock)	110	1120107	Eagle Rock
12 (Cobb Creek)	110	1120108	Fulton
13 (Big Geysers)	60	1120109	Lakeville
14 (Sulphur Springs)	114	1120110	Fulton
16 (Quicksilver)	119	1120111	Fulton
17 (Lake View)	119	1120112	Fulton
18 (Socrates)	119	1120113	Lakeville
20 (Grant)	119	1120114	Lakeville
Sonoma	78	1120434	Lakeville
Aidlin	20	1120106	Eagle Rock
Calistoga	80	1157478, 1157479	Lakeville
Bear Canyon ²	20	1119928	Fulton
West Ford Flat ³	27	1157570	Fulton

¹ The nameplate capacity values were taken from Brophy et al. (2010).

² The Bear Canyon power plant was taken out of commission by Calpine in 2015.

³ The cooling towers at the West Ford Flat power plant were destroyed in the 2015 Valley Fire (CAL FIRE, 2015) - this plant was permanently closed by Calpine after the fire.

Total Curtailment in different years

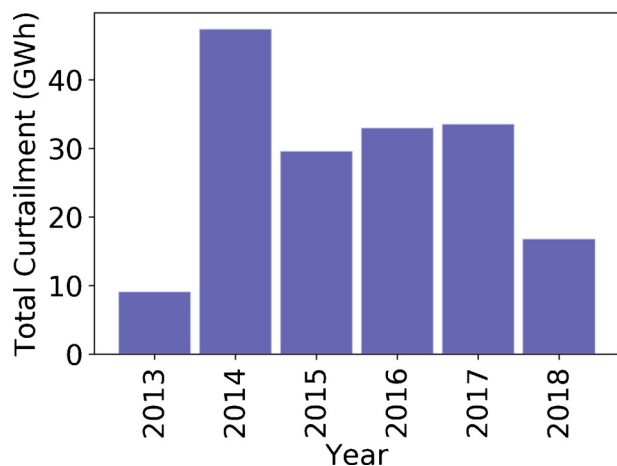

Fig. 6. Annual curtailment at The Geysers (for Calpine plants) between 2013 and 2018.

5674 GW h in 2017. The percentage of power curtailment relative to net generation over this time period ranged from 0.15 % (in 2013) up to 0.81 % (in 2014). These levels of curtailment are far below the 1.5 – 2 TW h annual curtailments that occurred at the Unocal portion (similar to the current Calpine holdings) of The Geysers in 1995 and 1996, which represented about 50%–75% of the net generation levels (Barker and Pingol, 1997).

5.2. Curtailment variability by season

Fig. 7 and Table 2 provide a summary of the seasonal variability of curtailment. The least amount of curtailment at The Geysers over the past six years has occurred over the winter months (Nov. to Feb.), when solar power generation is lower due to fewer hours of sunlight. Higher levels of curtailment generally occur in April and May, when cheap hydro is abundant due to spring runoff. Both high and low levels of

curtailment have been observed in August and October.

5.3. Curtailment variability by time of day

Both the power demand and generation vary throughout the day, as evidenced by the duck curve (Fig. 3). Thus, economic curtailment is also likely to exhibit an hourly variation that corresponds to periods when intermittent renewable energy resources are abundant and there is an oversupply of electricity to the system. Fig. 8 displays the hourly cumulative curtailment that has occurred at The Geysers between 2013–2018. While curtailment has occurred at all times throughout the day, the peak values of curtailment occur between the daylight hours of 8 am to 5 pm, when solar generation is highest (CAISO, 2019). Curtailment that occurs throughout the day is more likely to be longer lasting transmission-related curtailment.

5.4. Distribution of curtailment event durations

The duration of curtailment events occurring between 2013 and 2108 vary significantly, from a low of one hour (the minimum time scale of this study) up to over 400 h (Fig. 9). However, the vast majority of curtailment events are short lived. The majority of curtailment events are 4 h or less in duration, with most curtailment events being 2 h or less. The length of long-term curtailment events varies from year to year; the longest curtailment event in 2013 was approximately one day (25 h), whereas the longest event observed during the six years of this study (in 2014) was slightly less than 20 days long (475 h). These long-term events are related to transmission issues, and are not linked to negative pricing events, which generally are only a few hours long in duration.

5.5. Magnitude of curtailments

Curtailment only occurred 8.7 % of the time at The Geysers between 2013 and 2018, but the amount of curtailment that occurred at any given time varied significantly. The magnitude of curtailment occurring at The Geysers can be evaluated by looking at the frequency of different levels of curtailment (based on the hourly curtailment data) occurring on a field-wide basis over the period of analysis (2013–2018). Fig. 10 indicates that over 78 % of the times when curtailment occurred were 50 MW or less, with only 3.5 % (183 events) of all of the times when curtailment occurred having magnitudes greater than 100 MW and just 0.02 % (1 event) with a curtailment greater than 200 MW. While curtailment events are generally quite short in duration, some of the curtailments can ramp up quite quickly and have a significant fraction of total generation (> 40 %) curtailed. Fig. 11 depicts a large magnitude curtailment event that occurred in May of 2016, where in the space of 24 h, a curtailment with three episodes having maximum values of 200–300 MW occurred, each with a duration of about 2 h in length. The decrease in field production from ~650 MW to ~350 MW took place rapidly (generally within 30 min), and the ramp up back to full production was equally rapid. Two smaller (50–100 MW) and shorter duration (< 30 min) curtailment episodes occurred just prior to these larger curtailments.

5.6. Curtailment variability by transmission line groupings (congestion curtailment)

The Calpine power plants at The Geysers are connected to the grid by three main transmission lines (Fig. 5): the 230 KV Fulton substation (linked to Units 12, 14, 16, 17, Bear Canyon, and West Ford Flat), the 230 KV Lakeville substation (connected to Units 13, 18, 20, Sonoma, and Calistoga), and the 115 KV Eagle Rock substation (connected to Units 5&6, 7&8, 11, and Aidlin). The majority of curtailment (generally > 90 %, with slightly smaller values in 2013 (82 %) and 2017 (73 %)) at The Geysers during 2013–2018 occurred at the power plants

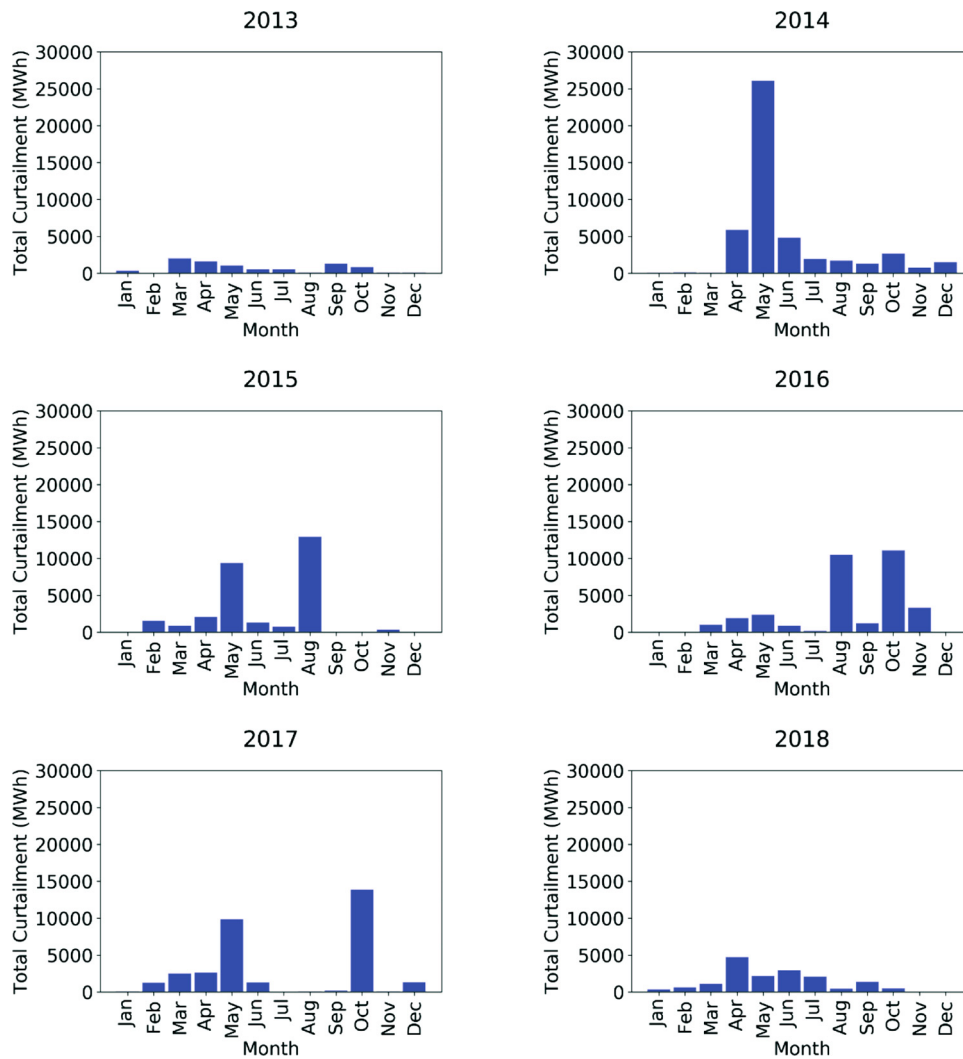

Fig. 7. Plots of total monthly curtailment for the years 2013-2018. The scales for each plot are the same to facilitate comparison between years.

Table 2
Months with low (< 150 MWh) (O), elevated (> 2-10 GWh) (X), and very high (> 10 GWh) (XX) cumulative curtailment.

	Jan	Feb	Mar	Apr	May	Jun	Jul	Aug	Sep	Oct	Nov	Dec
2013		O	X					O			O	O
2014	O		O	X	XX	X				X		
2015	O			X	X			XX	O			O
2016	O	O		X				XX		XX	X	O
2017	O		X	X	X		O	O		XX	O	
2018				X	X	X	X		X		O	O

associated with the smaller 115 KV Eagle Rock transmission line (Fig. 12). This observation suggests that much of the curtailment occurring at The Geysers is related to transmission constriction - some of this constriction could also be related to economic curtailment (with cheaper power being transmitted on the same transmission line).

5.7. Curtailment related to negative pricing (economic curtailment)

The relation between curtailment and negative pricing was examined to see if there were temporal (time of day, seasonal and annual) or spatial (variations relative to power plants clustered by transmission lines) correlations. To begin, temporal correlations were evaluated to see if the times when curtailment occurred coincided when negative pricing was most prevalent. The distribution of negative pricing on an

annual basis (Fig. 13) does not correspond with the variations in the magnitude of curtailment (Fig. 6), suggesting that factors other than negative pricing contribute to overall curtailment at The Geysers.

In addition to looking at annual variations in negative pricing, seasonal variability was also assessed. Fig. 14 depicts the distribution of negative pricing events on a monthly basis from 2013 to 2018. Most of the negative pricing occurs in the spring months; this tends to coincide with a peak in curtailment (Fig. 7) that generally occurs that time of year.

Finally, the distribution of when negative pricing occurred throughout the day was evaluated. For most years, this distribution was bimodal, with a small negative pricing peak in the early hours of the day (2-4 am) and a larger and wider negative pricing peak occurring between 8 am and 5 pm (Fig. 15). These peak negative pricing periods vary slightly from year to year, but there appears to be a more pronounced midday peak over the last three years, which may reflect the increase in solar generation over time. A similar bimodal distribution was observed for when curtailment occurs during the day (Fig. 8), suggesting a positive correlation between negative pricing and curtailment.

Another approach was to look at the actual nodal pricing during hours when curtailment occurred (Fig. 16) and group the power plants according to their transmission line connections (Eagle Rock, Fulton, and Lakeville – see Table 1 for more details). As noted earlier (Fig. 12), about 90 % of the curtailment at The Geysers occurs at the power plants

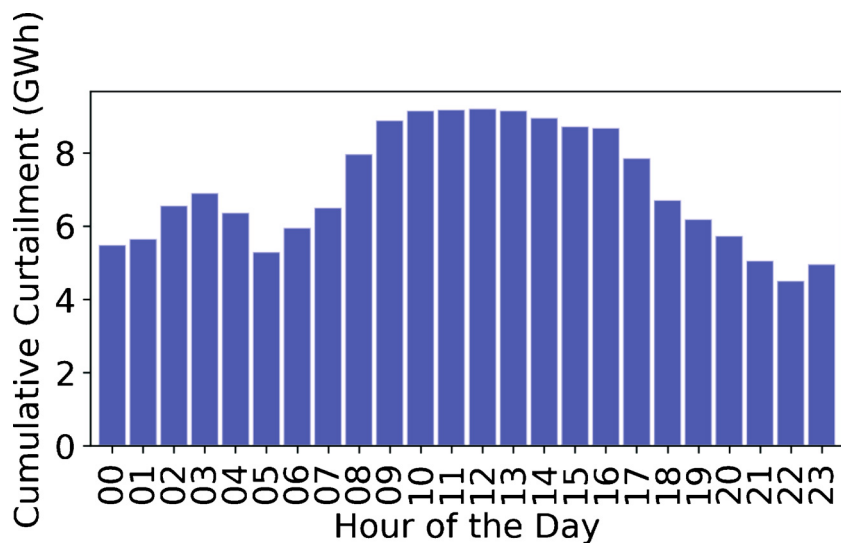

Fig. 8. Hourly variations in the amounts of curtailment that has occurred at The Geysers between 2013-2018.

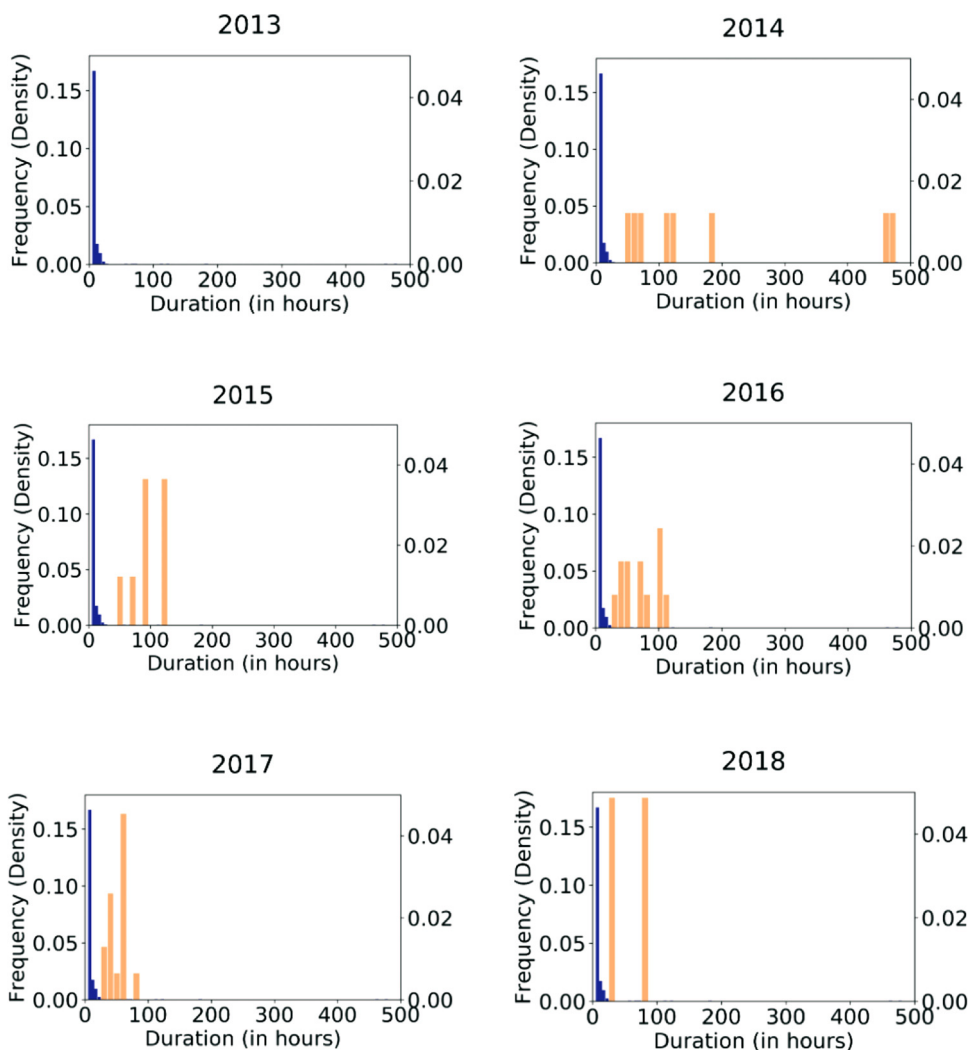

Fig. 9. The frequency distribution of the duration of curtailment events (grouped in 5-h bins) at The Geysers from 2013 to 2018. To facilitate viewing of the long-duration, low-frequency events, the data are plotted using a wider range of frequencies for the events spanning 1-25 h in length (plotted in blue, with the axis on the left), and a narrower range of frequencies for events greater than 25 h in length (plotted in orange, corresponding to the axis on the right) (For interpretation of the references to colour in this figure legend, the reader is referred to the web version of this article).

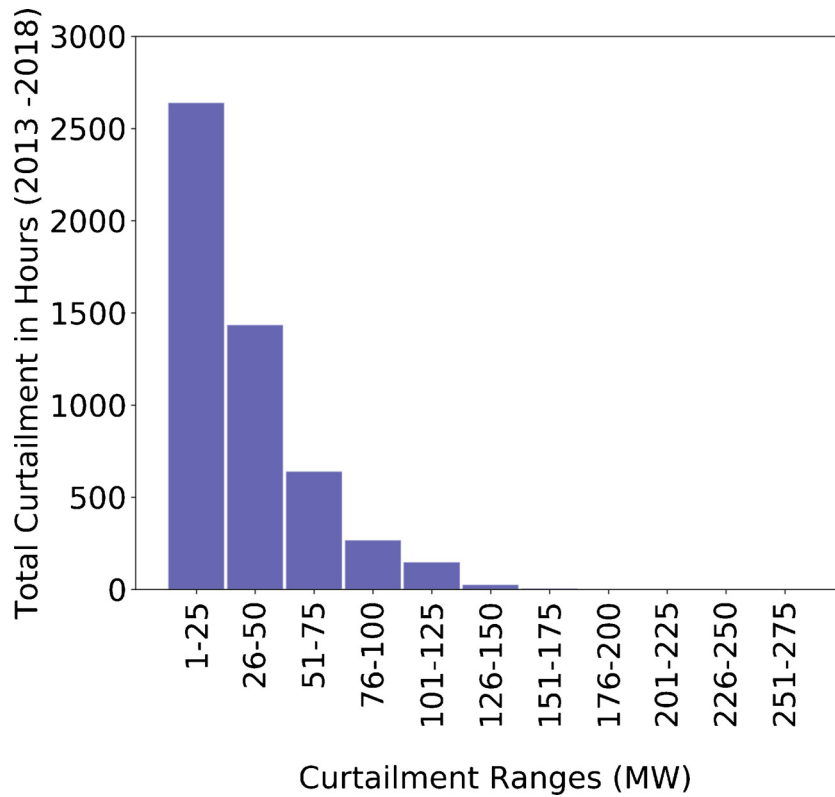

Fig. 10. Frequency of different levels of field-wide curtailment on an hourly basis at The Geysers between 2013-2018.

linked to the smaller Eagle Rock 115 KV transmission line. For the power plants associated with the larger capacity Fulton and Lakeville transmission lines, there is a clear correspondence between negative pricing and curtailment: the Lakeville plants experience curtailment with negative pricing 75 % of the time and this occurs at the Fulton plants 70 % of the time. For these two groups of plants, most of the positive pricing curtailment events occurred at very low (< 3 MW) curtailment levels. However, for the Eagle Rock plants, curtailment is linked to negative pricing only 37 % of the time, suggesting that transmission constriction is the main driver for curtailment for the

plants connected to this smaller capacity line.

6. Future forecasting of curtailment events based on past trends

This analysis of curtailment that has occurred at The Geysers from 2013 to 2018 does not identify many coherent trends that could be used to predict how curtailment may change in the future. The relative amounts of curtailment seemed to vary from year to year – years with more curtailment may reflect years with higher rainfall (and thus greater cheap hydro power). The increase in solar power generation

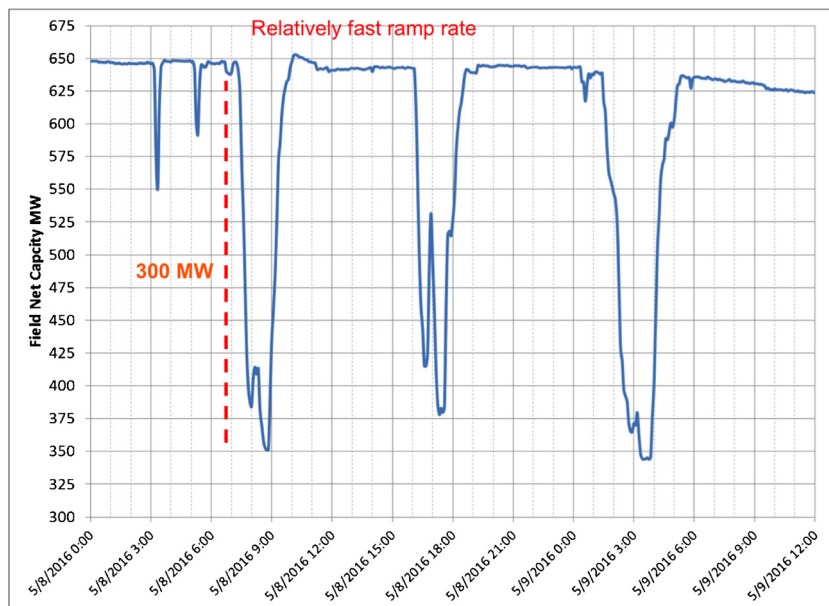

Fig. 11. Sequence of high-magnitude curtailment events occurring at The Geysers in May 2016.

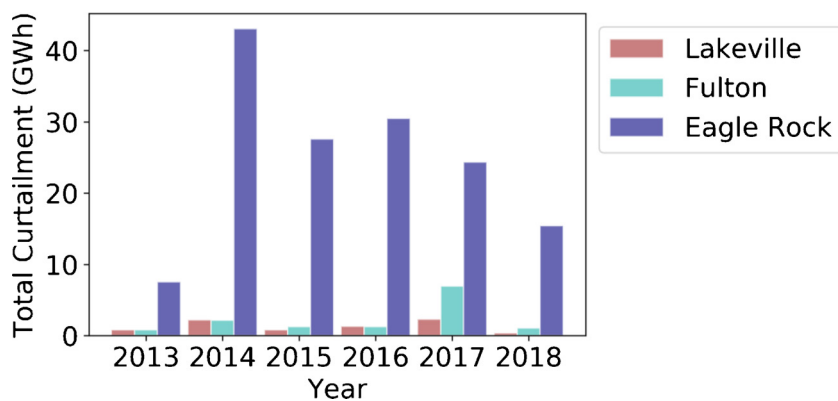

Fig. 12. Curtailment per year for power plants grouped by transmission lines at The Geysers (See Fig. 5 and Table 1 for grouping of power plants with transmission lines). Note that for all years except for 2013 and 2017, over 90 % of curtailment occurred at power plants linked to the lower capacity 115 KV Eagle Rock transmission line.

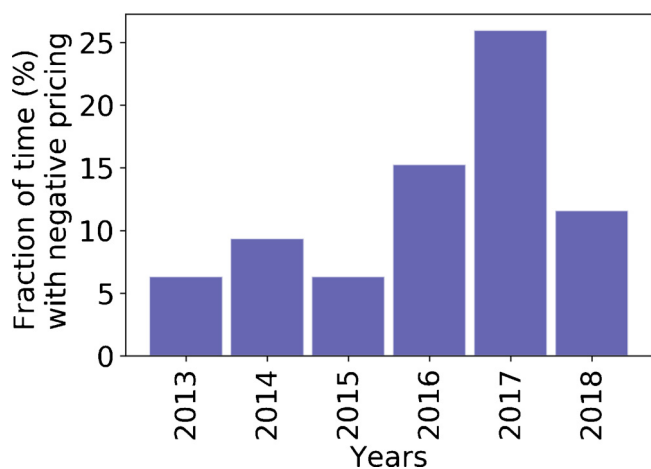

Fig. 13. Annual frequency of hourly negative pricing events at The Geysers (Calpine plants).

over time in California may be reflected in part by the higher curtailment and higher negative pricing occurring during the midday hours – however the decrease in curtailment (and negative pricing) in 2018 indicates that other factors (such as hydro generation) also play an important role in the amount and timing of curtailment. It appears that two main types of curtailment have impacted The Geysers. Short-term curtailment events are linked to economic factors and are driven by negative pricing. The majority of curtailment at The Geysers between 2013 and 2018 (~90 %) occurred at the power plants linked to the Eagle Rock transmission substation; much of this curtailment appeared to be linked to transmission limitations rather than to negative pricing. This factor may continue to dominate the location and cause of curtailment at The Geysers over the next few years. However, the legal requirement for increased renewable energy generation in California may result in increased economic curtailment during spring and summer daytime hours when there is an overabundance of solar energy generation. This may be moderated as more energy storage systems are brought online to help smooth out the gaps between supply and demand curves. If incentivized by pricing, flexible generation at The Geysers and other geothermal fields may help reduce the need for curtailment.

One likely explanation for the overall decrease in curtailment since 2014 is the Western Energy Imbalance Market. This market, created in late 2014, has resulted in the extension of CAISO’s real-time energy market to other balancing authority areas in the Western Interconnection (Price, 2018). The development and growth of this regional energy imbalance market has resulted in reduced curtailment of renewable resources.

7. Responses to curtailment at The Geysers

While the levels of curtailment that have been occurring over the past six years at The Geysers are much less severe than those experienced in the late 1990s, they have impacted net power generation and overall field operations. Calpine has made a number of physical and procedural modifications to field operations at The Geysers to be able to respond to curtailment requests (Urbank and Jorgensen, 2016). These modifications (Fig. 17) include:

- Development of pipeline cross ties that allow for steam from wells to be sent to more than one power plant and provide needed supply of make-up water
- Modifications to remote control valves and flow meters to deal with lower rates of steam flow
- Improved scrubbing of chlorides from steam for reduced flow conditions
- Developing control systems for H₂S abatement burners operating under reduced flow conditions
- Construction of turbine bypass systems to permit continuous operation for Unit 5 (direct contact condenser) and Unit 17 (surface condenser) that permit diverting steam to the condenser units without having power generation.

The construction of turbine bypasses at two of the power plants (similar to the system employed at the Puna geothermal field (Nordquist et al., 2013)) permits Calpine to accommodate larger magnitude curtailment events by being able to keep steam wells flowing while reducing power production. These modifications are the result of a comprehensive CEC study that Calpine has conducted to evaluate different approaches that would permit flexible generation at The Geysers.

8. General observations and conclusions

With increasing renewable energy portfolio standards and decreasing costs of wind and solar energy, variable (e.g., intermittent) renewable energy sources will provide a growing share of the energy mix in California. Model scenarios evaluating the increasing penetration of renewable energy in the power market indicate that there will be an increasing demand for flexible generation, both on hourly and seasonal scales (Cole and Frazier, 2018). This trend will put economic pressure (via negative pricing) on generators to be responsive to system load requirements. Thus, there is a significant incentive on the part of geothermal field operators to develop the capability to have load-following generation for the future power market.

Between 2013 and 2018, annual generation curtailments ranging between 9 and 47 GWh occurred at the Calpine power plants at The Geysers. While this level of curtailment is dwarfed by the much larger fieldwide curtailments that occurred at The Geysers in the late 1990s

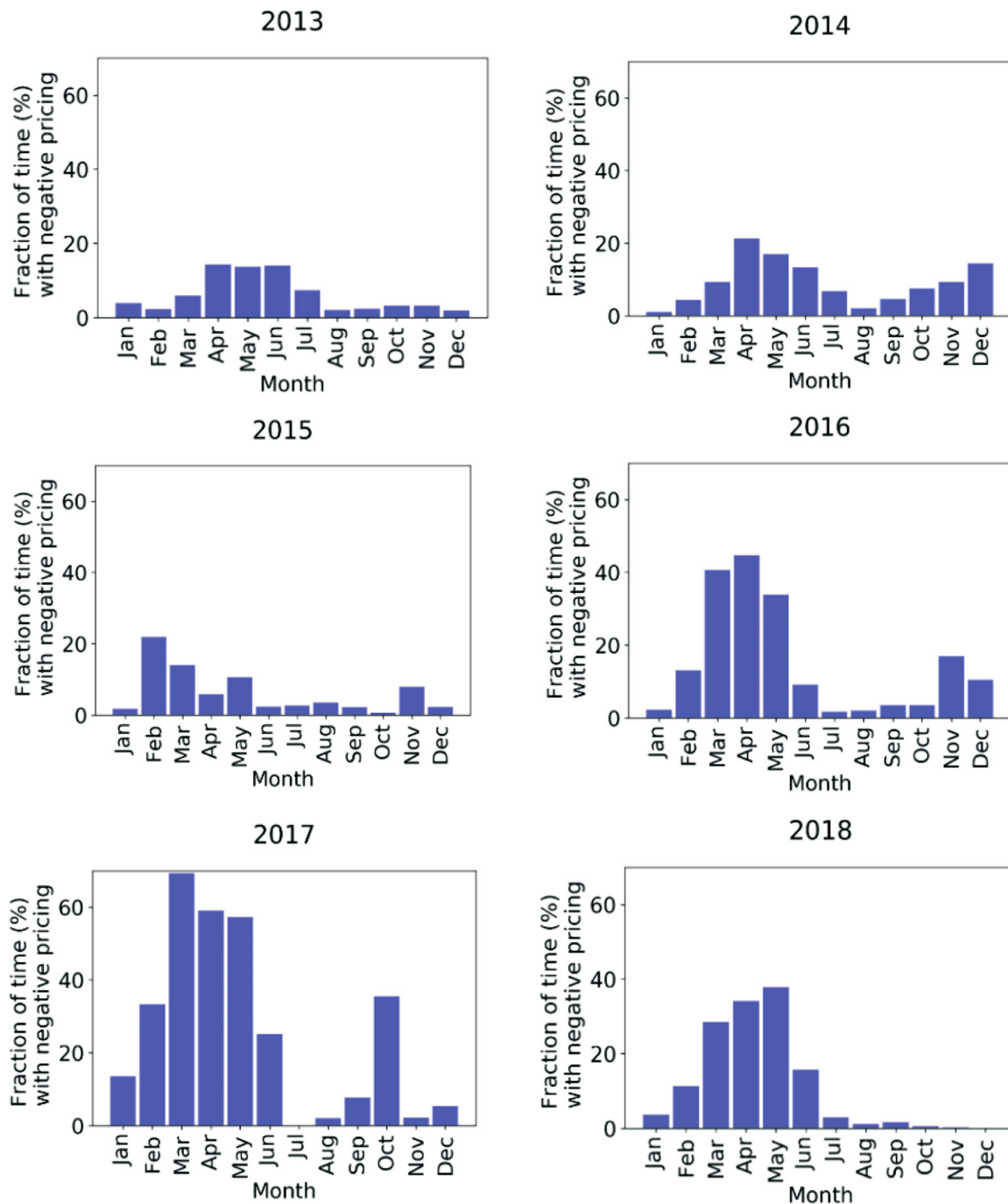

Fig. 14. Frequency of negative pricing on a monthly basis for The Geysers (Calpine power plants) from 2013 to 2018.

(almost 2 TWh annually), it still impacts field operations and profitability. Two general types of curtailment were observed: short-term events that were triggered by system-wide negative pricing factors (economic curtailment) and longer-term events that generally occurred at power plants connected to a smaller capacity transmission line (transmission capacity curtailment). Economic curtailment appears to be linked to both hourly and seasonal trends when abundant forms of inexpensive power result in negative pricing (abundant hydro power in the springtime of wet years, and abundant solar during spring and summer daytime hours). System pricing pressures are somewhat dampened by long-term power purchase agreements and by renewable energy credits.

The magnitude of curtailment (0.15–0.81 % of annual net generation) at The Geysers during the period of study (2013–2018) is much

lower than that which occurred in 1995 and 1996. The curtailment events that occurred between 2013 and 2018 were not of sufficient magnitude and duration to result in any detectable increases in reservoir pressure that would result in a “puff” in production following the curtailment events; thus it would be difficult to recoup lost generation during curtailment by increasing production rates for a short time following curtailment. The intermittent nature and short (generally ≤ 4 h) duration of most curtailment events also makes it challenging to utilize steam during curtailment for other economic uses.

The Calpine CEC flexible generation study noted that the primary constraints on flexible operation include corrosion, avoiding gas and condensate buildup in pipelines, unstable formation and manual valve changes. Steam well and pipeline corrosion from HCl acid-dewpoint corrosion is a major constraint on steam-field operations and steam-

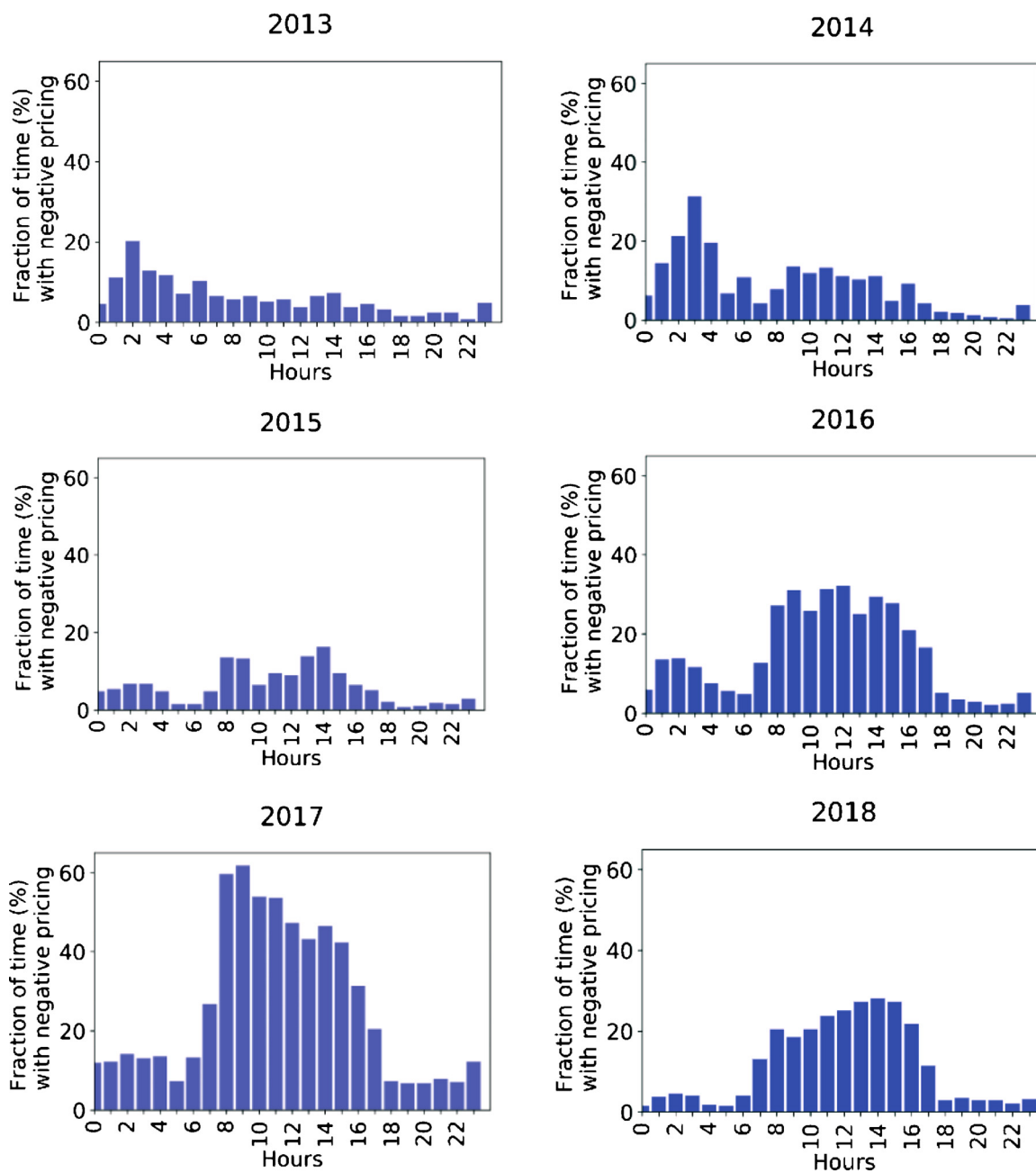

Fig. 15. Hourly frequency of negative pricing at The Geysers (for Calpine power plants) for each year between 2013 and 2018.

scrubbing systems that limits the ability to curtail steam production in areas of high-HCl steam. Thus, it is preferable to curtail flow in steam wells with high superheat from portions of the reservoir with relatively low HCl gas contents, as models suggest that such wells would not experience condensation even when flow rates are significantly reduced. Periodic curtailment may have contributed to limited amounts of corrosion that has occurred in some wells at The Geysers geothermal field.

Additional modeling work conducted by Rutqvist et al. (2020) notes that for steam-dominated systems, the main wellbore concerns would be thermal cycling of the production wells, which could lead to mechanical damage to the cement and casing, and cooling of the wellbore resulting in condensation of steam and HCl, leading to corrosion of casing. For liquid-dominated geothermal systems with binary power plants (where the produced fluids do not flash to steam), there are similar concerns with mechanical damage to the cement and casing of the production wells caused by thermal cycling, but these wells are also

faced with the potential for mineral scaling if fluid temperatures drop too much (Rutqvist et al., 2020). Geochemical modeling suggests that scaling will not be a problem for liquid-dominated systems with fairly low salinities (< 2000 ppm TDS), such as Casa Diablo, but this could be a significant issue for systems with highly saline brines, such as in the Imperial Valley. The impacts from well throttling or shut-in can be avoided by using a turbine bypass – production wells could continue to flow during curtailment, but the steam would not be delivered to the power plant (Nordquist et al., 2013; Urbank and Jorgensen, 2016). While this approach would minimize potential damage to the well field, it also does not maximize the utilization of the geothermal resource.

In modifying the operations of geothermal fields from baseload to flexible power generation, the two main options that are envisioned are: 1) develop internal strategies to help adapt power production to a more flexible generation schedule and reduce the negative impacts associated with curtailment, which would need to be incentivized financially through higher prices when ramp up is required to offset the

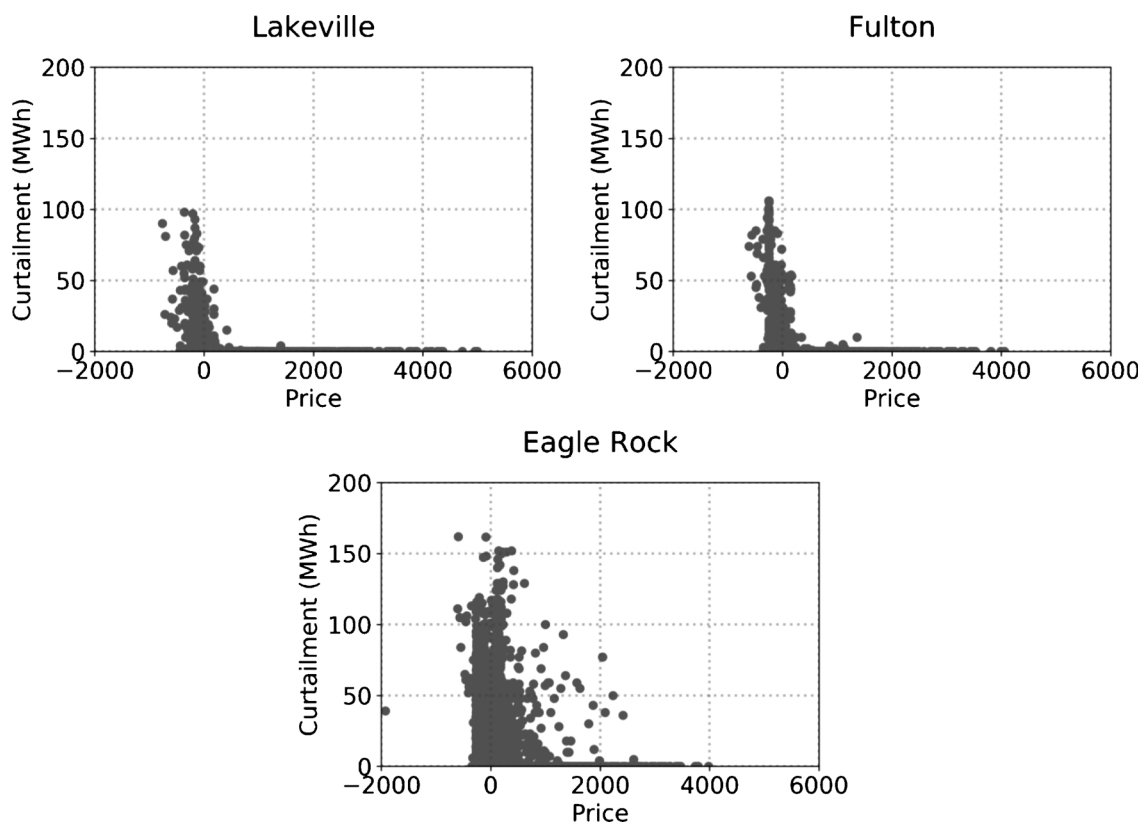

Fig. 16. Hourly cumulative curtailment (MW) plotted vs. the average nodal pricing (\$/MWh) for the Lakeville (top left), Fulton (top right), and Eagle Rock (bottom) groups of Calpine power plants at The Geysers. Note the much higher correlation between curtailment and negative pricing for the Lakeville and Fulton groups of power plants. Nodal pricing data obtained using ABB Velocity Suite.

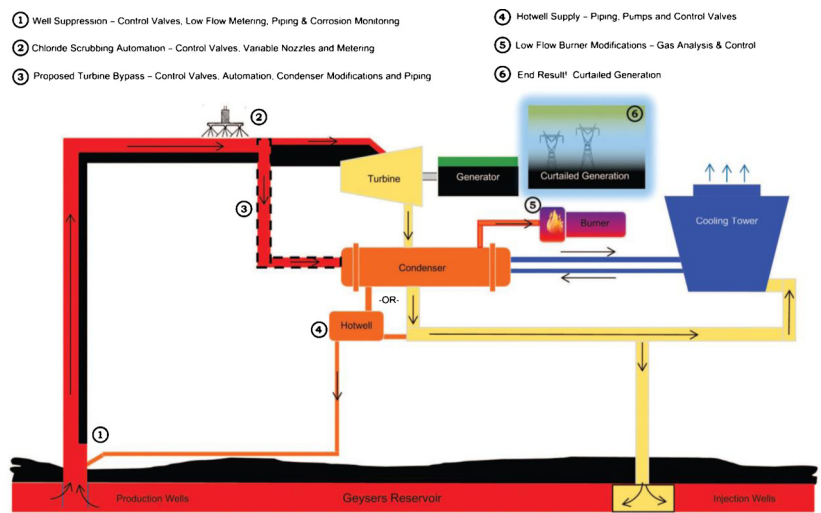

Fig. 17. Existing and proposed modifications to field operations at The Geysers to respond to curtailment (from Urbank and Jorgensen, 2016).

loss in revenue when curtailment occurs, and 2) develop energy storage solutions where excess power generation could be stored and then later dispatched when power demands increase. These alternative energy systems could include using excess geothermal capacity for powering pumped hydro storage, compressed gas storage, thermal energy storage, battery storage, and the generation of hydrogen. With increasing levels of intermittent renewable energy being produced in California, curtailment is expected to increase, so developing viable options to reduce the effects of curtailment is needed. The Western Energy Imbalance Market has reduced curtailment of renewable resources by opening up the California energy market to larger number of balancing

authority areas. This evaluation of curtailment at The Geysers should provide needed constraints on which approaches, such as flexible generation or energy storage, are best suited to respond to curtailment in the future.

CRediT authorship contribution statement

Patrick Dobson: Conceptualization, Methodology, Formal analysis, Investigation, Writing - original draft, Writing - review & editing, Visualization, Supervision, Project administration, Funding acquisition.
Dipankar Dwivedi: Methodology, Software, Validation, Formal

analysis, Investigation, Data curation, Writing - original draft, Writing - review & editing, Visualization, Supervision. **Dev Millstein:** Methodology, Software, Formal analysis, Visualization, Investigation, Resources, Writing - original draft, Funding acquisition. **Nandini Krishnaswamy:** Software, Formal analysis, Visualization. **Julio Garcia:** Methodology, Validation, Resources, Writing - original draft. **Mariam Kiran:** Software, Supervision.

Declaration of Competing Interest

The authors declare that they have no known competing financial interests or personal relationships that could have appeared to influence the work reported in this paper.

Acknowledgments

This work was supported by the U.S. Department of Energy, Office of Energy Efficiency and Renewable Energy (EERE), Office of Technology Development, Geothermal Technologies Office (GTO), under Award Number DE-AC02-05CH11231 with LBNL. This work was in collaboration with Deep Learning FP00006145, which is supported by the U.S. Department of Energy, Office of Science Early Career Research Program under LAB 16-1625. We also wish to thank Calpine Corporation for providing extensive access to their operational data, which made this analysis possible. We thank Susan Hamm of DOE GTO for her constructive comments on an early version of this manuscript, John Farison of Calpine for his insights regarding the Western Energy Imbalance Market, and two anonymous reviewers for their helpful feedback that improved this manuscript.

Appendix A. Supplementary data

Supplementary material related to this article can be found, in the online version, at doi:<https://doi.org/10.1016/j.geothermics.2020.101871>.

References

- ABB Enterprise Software, 2017. ABB Velocity Suite.
- Barker, B.J., Pingol, A.S., 1997. Geysers reservoir performance - an update. In: Proceedings, 22nd Workshop on Geothermal Reservoir Engineering. Stanford University, Stanford, CA, SGP-TR-155. pp. 125–132.
- The geysers geothermal field – update 1990-2010. In: In: Brophy, P., Lippmann, M.J., Dobson, P.F., Poux, B. (Eds.), Geotherm. Res.Counc. Special Report 20. pp. 237.
- CAISO, 2016. What the Duck Curve Tells Us About Managing a Green Grid - Fast Facts. http://www.caiso.com/Documents/FlexibleResourcesHelpRenewables_FastFacts.pdf.
- CAISO, 2017. Impacts of Renewable Energy on Grid Operation - Fast Facts. <http://www.caiso.com/Documents/CurtailmentFastFacts.pdf>.
- CAISO. Regional energy markets & California's green goals Presentation to the Assembly Utilities & Energy Committee Informational Hearing, Mark Rothleder, VP for Renewable Integration and Market Quality 14 2018March http://www.caiso.com/Documents/RegionalEnergyMarkets_CaliforniasGreenGoals.pdf.
- CAISO, 2019. 2019 Summer Loads & Resource Assessment. <http://www.caiso.com/Documents/2019SummerLoadsandResourcesAssessment.pdf>.
- CAL FIRE, 2015. Valley Incident Damage Inspection Report, CAL FIRE Incident Management Team 3. Report CALNU008670. .
- Cole, W., Frazier, A.W., 2018. Impacts on increasing penetration of renewable energy on the operation of the power sector. *Electr. J.* 31, 24–31.
- Cooley, D., 1996. A report on cycling operations at The Geysers power plant. *Geotherm. Res. Counc. Trans.* 20, 729–732.
- Dellinger, M., 2016. Recharging the Geysers. *Geotherm. Res. Counc. Bulletin*, July/Aug 36–40.
- Edmunds, T.A., Sotorrio, P., 2015. Ancillary service revenue potential for geothermal generators in California. In: Proceedings, 40th Workshop on Geothermal Reservoir Engineering. Stanford University, Stanford, CA, SGP-TR-204. pp. 12.
- Geothermal Resources Council, 2015. Wildfire damages geothermal plants at The Geysers. *Geotherm. Res. Counc. Bulletin* Nov./Dec. pp. 14–15.
- Golden, R., Paulos, B., 2015. Curtailment of renewable energy in California and beyond. *Electr. J.* 28 (6), 36–50.
- Goyal, K.P., 2002. Reservoir response to curtailments at The Geysers. In: Proceedings, 27th Workshop on Geothermal Reservoir Engineering. Stanford University, Stanford, CA, SGP-TR-171. pp. 7.
- Goyal, K.P., Conant, T.T., 2010. Performance history of The Geysers steam field, California. USA. *Geothermics* 39, 321–328.
- Hernandez, K., Wendt, D., Mattson, E., 2017. Potential benefits and opportunities for load following geothermal power plants in California. *Geotherm. Res. Counc. Trans.* 42, 13.
- Matek, B., 2015. Flexible opportunities with geothermal technology: barriers and opportunities. *Electr. J.* 28 (9), 45–51.
- Nordquist, J., Buchanan, T., Kaleikini, M., 2013. Automatic generation control and ancillary services. *Geotherm. Res. Counc. Trans.* 37, 761–766.
- Price, J.E., 2018. Measuring market results of the western energy imbalance market. IEEA 5 Paper 18PESGM0514.
- Rutqvist, J., Pan, L., Hu, M., Zhou, Q., Dobson, P., 2018. Modeling of coupled flow, heat, and mechanical well integrity during variable geothermal production. In: Proceedings, 43rd Workshop on Geothermal Reservoir Engineering, Stanford University. Stanford, CA, SGP-TR-213. pp. 13.
- Rutqvist, J., Pan, L., Spycher, N., Dobson, P., Zhou, Q., Hu, M., 2020. Coupled processes analysis of flexible geothermal production from steam- and liquid-dominated systems: impacts on wells. In: Proceedings, 45th Workshop on Geothermal Reservoir Engineering, Stanford University, Stanford, CA, SGP-TR-216. pp. 17.
- Sanyal, S.K., Eney, S.L., 2016. Fifty-five years of commercial power generation at The Geysers geothermal field, California: the lessons learned. In: DiPippo, R. (Ed.), *Geothermal Power Generation*. Woodhead Publishing, pp. 591–608.
- Schmitt, W., 2020. Santa Rosa wastewater quandary linked to Kincadee fire could get worse as rainy season ramps up. *Press Democrat* 3 (January). <https://www.pressdemocrat.com/news/10513689-181/santa-rosa-wastewater-quandary-linked?sbA=AAS>.
- Stark, M.A., Box Jr., W.T., Beall, J.J., Goyal, K.P., Pingol, A.S., 2005. The Santa Rosa-Geysers recharge project, Geysers geothermal field, California. *Geotherm. Res. Counc. Trans.* 29, 219–224.
- Urbank, K., Jorgensen, A., 2016. Investigating flexible generation at The Geysers. *Geotherm. Res. Counc. Bulletin*, Sept./Oct. 36–39.
- Woo, C.K., Moore, J., Schneiderman, B., Ho, T., Olson, A., Alagappan, L., Chawla, K., Toyama, N., Zarnikau, J., 2016. Merit-order effects of renewable energy and price divergence in California's day-ahead and real-time electricity markets. *Energy Policy* 92, 299–312.