

UC Davis

Research Reports

Title

Comparison of Hybrid Fuel Cell Vehicle Technology and Fuel Efficiency

Permalink

<https://escholarship.org/uc/item/9br0w0xz>

Authors

Zhao, Hengbing

Burke, Andrew

Miller, Marshall

Publication Date

2011-05-01

Research Report – UCD-ITS-RR-11-10

Comparison of Hybrid Fuel Cell Vehicle Technology and Fuel Efficiency

May 2011

Hengbing Zhao
Andrew Burke
Marshall Miller

Comparison of Hybrid Fuel Cell Vehicle Technology and Fuel Efficiency

H. Zhao, A. Burke, and M. Miller

Institute of Transportation Studies, University of California, Davis, CA.

Abstract:

Hybridization of fuel cells with additional batteries or ultracapacitors in a fuel cell vehicle reduces electrical and mechanical stresses on fuel cells and improves the overall drive train efficiency over a standard drive cycle. This paper primarily analyzes hybrid fuel cell vehicles with different drive train arrangements, and compares projected fuel economies of hybrid fuel cell vehicles with improved conventional vehicles and hybrid electric vehicles at three points in the future: 2015, 2030, and 2045. The key points addressed are as follows: drive train arrangements, control strategies, and the influence of energy storage sizing on vehicle fuel economy. The study shows that fuel cell vehicles having ultracapacitors coupled with fuel cells via a DC/DC converter with load-leveling control is the best approach in term of improving fuel economy and mitigating the stress on the fuel cell. Power-assist control is well suited for fuel cell-battery hybrids in terms of fuel economy improvement. Fuel cell vehicles achieve about twice the fuel economy of the improved conventional vehicles and only about 15 percent better fuel economy compared to the hybrid electric vehicles.

1 Introduction

In automotive applications, the fuel cell system has to be able to adapt to critical operating conditions such as frequent start-up and stop, sudden load changes, and widely varying power levels. These rapid changes in the operating conditions can have a major impact on the lifetime of the fuel cell stack due to the mechanical and electrical stresses on the MEA and the stack accessory components. This impact can be reduced by hybridizing the fuel cell system with the addition of electrical energy storages such as batteries or ultracapacitors. There are presently a number of technologies being developed that will reduce the impact on fuel cells and at the same time improve vehicle fuel economy. Considering hybridization of fuel cell vehicles, designers have many choices to consider. These include the physical arrangement of the power sources, selection of the energy storage technology and devices, and the control strategy for splitting power between two power sources [1,2]. The following drive train arrangements have been considered in the development of fuel cell vehicles. Fuel cell vehicles (FCVs) without energy storages, FCVs with ultracapacitors directly connecting to fuel cells, FCVs with energy storages (batteries or ultracapacitors) coupled to fuel cells via a DC/DC converter (fuel cell dc-link), and FCVs with fuel cells coupled to batteries via a DC/DC converter (battery dc-link).

Midsize Fuel cell passenger cars with the above drive train configurations were simulated on different drive cycles using load-leveling and power-assist power splitting control

strategies. In these simulations the size of the energy storages and control strategies were varied to reflect effect of energy storages and control strategies on fuel economy.

It's also interested to compare fuel cell hybrid electric vehicles (FCHEV) with conventional internal combustion engine/transmission (ICE) and hybrid electric vehicle (HEV) technologies in terms of fuel economy in the future. Simulations of the three advanced vehicles on different driving cycles using the best component models available and control strategies intended to maximize the driveline efficiency. In these simulations the vehicle and component characteristics were selected to match those used in the DOE study [3].

This paper first describes in detail the fuel cell system dynamic model, fuel cell vehicle model, drive train arrangements, and the power splitting strategies that were used in this work. Then the results of our simulations in terms of fuel economy of the various vehicle designs are compared and presented. Finally, the fuel economy of the fuel cell-battery hybrids are simulated to project fuel reductions in fuel usage at three points in the future, and are compared with conventional ICEs and hybrid electric vehicles in terms of fuel economy and fuel saving in the same time periods.

2 Fuel Cell System, Vehicle Model and Control Strategies

2.1 Fuel Cell System Model

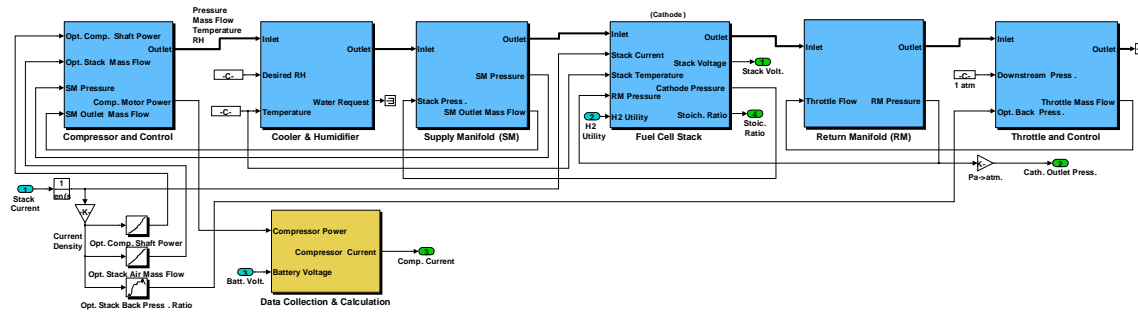

Figure 1 Diagram of the dynamic fuel cell system model (Air supply)

As a next generation power source for automotive applications, fuel cells can deliver electricity with high efficiency. However, the operation of the on-board auxiliaries such as the air supply compressor, cooling pump and radiator fan can significantly affect the performance of the fuel cell system and the fuel cell vehicle. Hence the operating strategy and resultant transients of the fuel cell system can have a significant impact on the system efficiency and thus vehicle fuel economy. Optimum varying back pressure varying air flow stoichiometry operation was used to maximize net output power and efficiency of the fuel cell system [4]. A dynamic air system consisting of the compressor and its control, supply manifold, cooler and humidifier, fuel cell stack, return manifold, and throttle and its control was employed in the fuel cell vehicle model. The dynamic model incorporates either fundamental equations, as in the fuel cell stack, or performance based maps, as for the compressor. The model was developed by using Matlab®/Simulink®, as shown in Figure 1. The inputs are the required current and the optimum operating conditions for the fuel cell system and the output is the stack voltage. The rotational speed of the compressor and the pressures in each stage of the air supply

system are the state variables. The optimum stoichiometry and back pressure conditions were used in the simulation.

2.2 Fuel Cell Vehicle Model

The fuel cell vehicle model used in this study is a forward-looking vehicle model developed using Matlab-Simulink®, which can simulate both the dynamics of the fuel cell system and the vehicle. Figure 2 gives the block diagrams of fuel cell vehicle with ultracapacitors coupled with fuel cell via a converter. The driver end of the fuel cell vehicle model consists of three main blocks: drive cycle, driver, and vehicle. The block of drive cycle defines the driving profile as velocity vs. time. The driver block represents the driver properties, generating the acceleration and brake commands to the vehicle block according to the driving cycle and the actual vehicle velocity. The block of vehicle includes vehicle body, traction motor and transmission, fuel cell system, and energy storage system and power splitting control. The DC-link voltage depends on the drive train configuration, which can be fuel cell stack voltage or energy storage voltage.

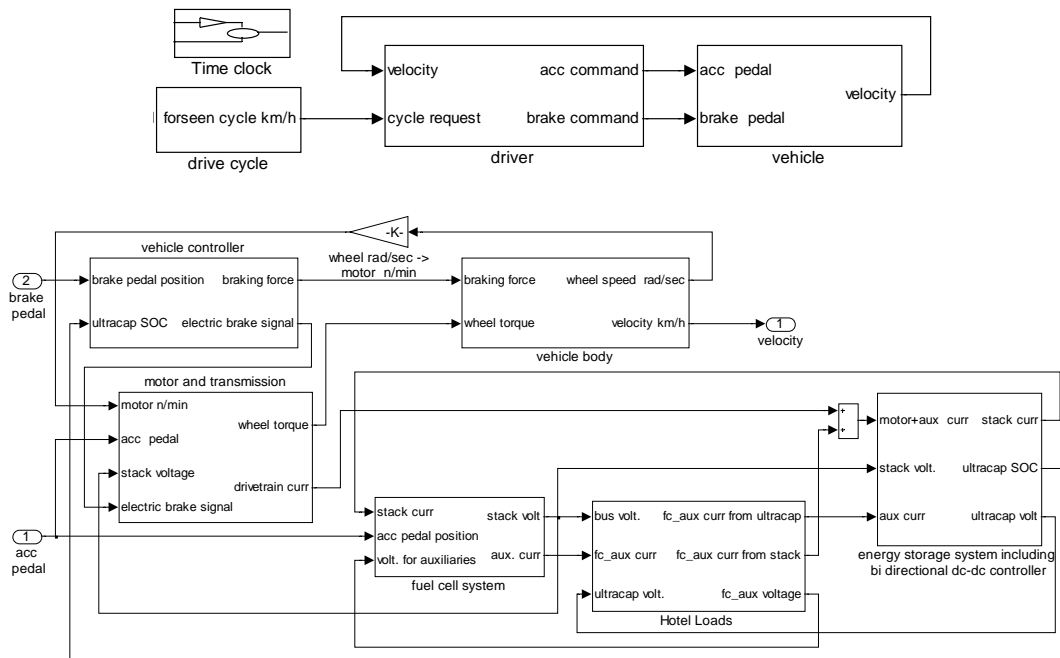

Figure 2 Driver end and vehicle model of fuel cell vehicle with ultracapacitors coupled to fuel cells via power electronics

2.3 Drive Train Configuration

Various fuel cell vehicle developers use different drive train configurations and energy storage technology in their vehicles. There are four practical arrangements of power sources. Each of the power sources arrangements has its advantages and disadvantages relative to operating conditions, control complexity, development cost, vehicle performance, and fuel economy potential. Figure 3 illustrates schematically the fuel cell drive train arrangements considered in this paper.

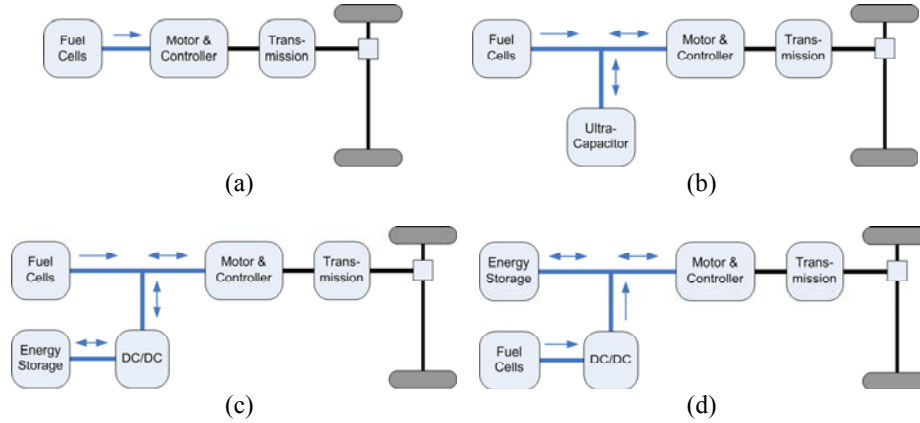

Figure 3 Drive train configurations of fuel cell vehicles

- Fuel cell vehicles (FCVs) without energy storages
- FCVs with ultracapacitors directly connecting to fuel cells
- FCVs with batteries or ultracapacitors coupled to fuel cells via a DC/DC converter (fuel cell dc-link)
- Fuel cells coupling to batteries or ultracapacitors via a DC/DC converter (battery/ultracapacitor dc-link)

There is a need to model the various fuel cell vehicle configurations and to simulate their performance/hydrogen consumption for different sizes of energy storage unit. In this study, the four fuel cell vehicle configurations (a-d) are evaluated in terms of fuel economy via vehicle simulations. Ultracapacitors are used in configurations (b), (c) and (d). Li-ion batteries are utilized in the configuration (c) for comparison with the systems using ultracapacitors.

2.4 Control Strategies

The fuel cell operation (power, voltage, current vs. time) and hydrogen consumption (fuel economy) are closely related to the strategy utilized to split power between the fuel cell and the energy storage as the vehicle is operated over various driving cycles. The general objective of any control strategy is to operate the fuel cell system only in its high efficiency region, avoiding operation in the very low power and very high power regions. Power-assist and load-leveling control strategies are usually used in fuel cell hybrid vehicles. Power-assist control splits the power/current demand of the traction motor i_{motor} based on the fuel cell voltage V_{fc} and the energy storage SOC . The current command for the energy storage device i_{ess} is expressed in equation (1) with the fuel cell providing the remaining current (equation 2).

$$i_{ess} = f_{fc}(V_{fc}) \cdot f_{ess}(SOC) \cdot i_{motor} \quad (1)$$

$$i_{fc} = i_{motor} - i_{ess} \quad (2)$$

where f_{fc} and f_{ess} are factors related to fuel cell voltage and energy storage device SOC , respectively. If the fuel cell voltage remains relatively high, it will provide most of the current to the motor. When the fuel cell voltage becomes low, the energy storage device will provide a large fraction of the current demanded by the motor.

In load-leveling control, the fuel cell provides relatively steady power and the energy storage device provides transient power. The fuel cell current command i_{fc} is calculated by averaging the traction motor current i_{motor} over a specified time period.

$$i_{fc} = i_{ave} \quad (3)$$

$$i_{ess} = i_{motor} - i_{ave} \quad (4)$$

Both control strategies maintain the *SOC* of the ultracapacitor or battery within a specified range. Compared to the power-assist control, load-leveling control permits the fuel cell to operate within a relatively narrow high efficiency region. This mitigates the stress on the fuel cell and maximizes fuel cell life by utilizing the energy stored in the ultracapacitor or battery to meet high power transients. However, a significant fraction of the transient power passes through the DC/DC converter for leveling the fuel cell current, which introduces significant losses in the power electronics.

For fuel cell vehicles with ultracapacitors coupled directly in parallel with fuel cells, no dc/dc converter is employed. The voltages of the ultracapacitor unit and fuel cell are equal. The current of the ultracapacitors is governed by the differential equation (5).

$$\frac{dV}{dt} = \frac{i_{cap}}{C} + R_{cap} \frac{di_{cap}}{dt}, \quad \frac{dV_{cap}}{dt} = \frac{dV_{fc}}{dt} \quad (5)$$

3 Fuel Cell Vehicle Simulations

3.1 Vehicle simulation inputs

Simulations of the operation of fuel cell hybrid vehicles using various drive train arrangements and energy storage technologies (ultracapacitors and Li-ion batteries) were performed using the UCD fuel cell vehicle simulation program. Simulations were performed using both the power-assist and load-leveling control strategies. In addition to the choice of drive train arrangements and energy storage technologies, the simulations have been run with different sizes of energy storage (Ah or Wh) in order to evaluate the effect of energy storages on fuel economy. Increasing the averaging time in the load-leveling control strategy leads to a larger fraction of transient power passing through the energy storage unit and results in greater losses in the charging and discharging of the energy storage unit. In this study, a 60-second simple moving average is used for leveling the power requirement for the fuel cell system.

In the simulation the battery *SOC* is limited to the range between 0.6 and 0.8. In addition, the regenerative braking currents are limited to protect the batteries from over voltage. The minimum voltage of the ultracapacitor is set as 50 percent of its rated voltage. The maximum usable energy is then 75 percent of the total energy stored in the capacitor. The ultracapacitor $SOC = 1 - [(V_{rated} - V)/(V_{rated}/2)]$ is controlled to be between 0.95 and 0.2. Empirical data of a 450 F ultracapacitor and a 20 Ah Li-ion cell obtained from testing at UC Davis are utilized and scaled in the energy storage unit models.

Simulations were performed for mid-size vehicles without energy storage, with ultracapacitors directly connected in parallel with the fuel cell, with the fuel cell connected to ultracapacitor DC-Link via a DC/DC converter, and with ultracapacitors and Li-ion batteries coupled with the fuel cell through a DC/DC converter. All the drive

trains were simulated in the same vehicle having the same road load characteristics shown in Table 1. The fuel cell system generated a net output power of 87.6 kW. The total vehicle mass was adjusted to reflect the type and capacity of energy storage and was recalculated based on the specific energy of energy storage units. The rated traction motor power was 75 kW for all cases. An empirical efficiency map of a bi-direction DC/DC converter, indexed by the input/output voltage ratio and the output power, was employed in the model.

Table 1 Vehicle simulation parameters

Vehicle and System Parameters	
Drag Coefficient	0.3
Frontal Area (m ²)	2.2
Rolling Resistance	0.01
Vehicle Hotel Load (kW)	0.3
Vehicle Mass without energy storage (kg) *	1500
Electric Motor (kW)	75
Fuel Cell Stack and Auxiliaries	
Max. Net Power (kW)	87.6
Gross Power (kW)	106
Number of Cells	440
Cell Area (cm ²)	510
Compressor (kW)	17.2
Energy Storages	
Ultracapacitor Capacity (Wh)	120
Ultracapacitor Module No. in Series	160**
Li-ion Battery Capacity (kWh)	0.8
Li-ion Battery Module No. in Series	144

* Vehicle mass recalculated based on the size and type of energy storage.

** 148 is for the case with ultracapacitors connected without interface electronics.

3.2 Fuel Cell Vehicle Simulation Results

Fuel cell-battery hybrids having an 800 Wh Lithium ion battery coupled with the fuel cell via power electronics were simulated over the US06 driving cycle. Both power-assist and load-leveling control strategies were applied to the model in the simulation. Figure 4 shows the fuel cell and battery currents for the power-assist and load-leveling control strategies over the US06 cycle. Compared to power-assist strategy, load-leveling control mitigates to a greater extent the load fluctuations on the fuel cell which results less stress on the fuel cell stack. However, for this strategy a significant fraction of the power/energy passes through the DC/DC converter for charging and discharging the energy storage, which leads to significant losses in the electronics.

Fuel cell vehicles with different drive train arrangements were performed over the FUDS driving cycle. The vehicle inputs used in the simulations are given in Table 1. A 60s moving average is used for load-leveling the fuel cell in fuel cell hybrid vehicles having power electronics. The current of the fuel cells for the various cases on the FUDS cycle are plotted in Figure 5. Comparisons of the simulation results indicate that all the drive train configurations using energy storages can significantly load-level the fuel cell operation - that is considerably reduce the maximum current and the current transient dynamics and thus mitigates the stress on the fuel cell stack. Compared to fuel cell

vehicles using the ultracapacitor, the current fluctuations are somewhat less than using the battery.

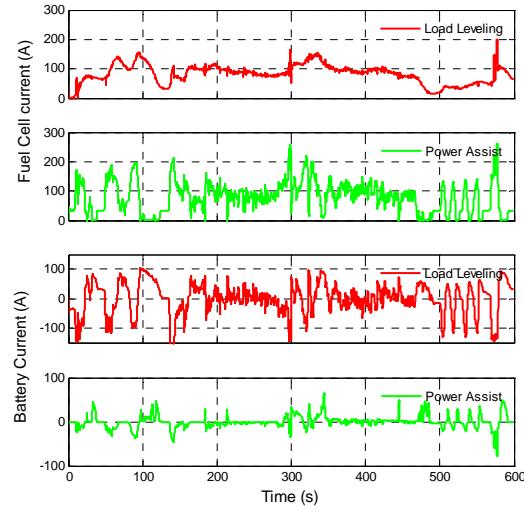

Figure 4 Comparison of load-leveling and power-assist control over the US06 cycle

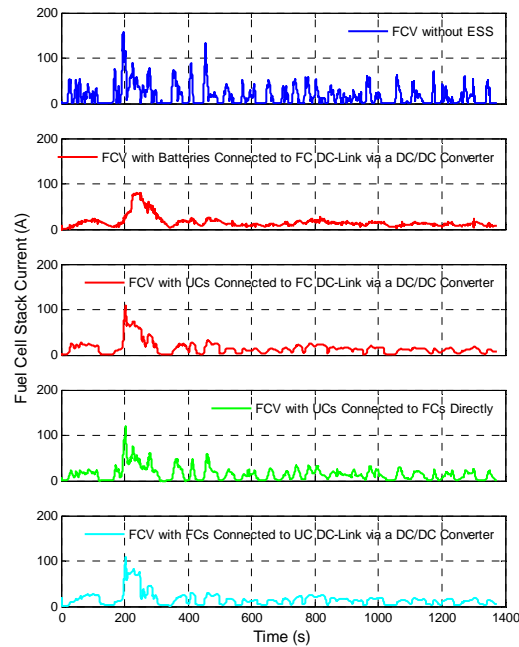

Figure 5 Comparison of the fuel cell current of different fuel cell hybrid vehicles

Simulations were performed for fuel cell-ultracapacitor hybrid vehicles with the load-leveling control strategy over the FUDS driving cycles. The ultracapacitor capacity was varied between 80 Wh and 200 Wh. Figure 6 shows fuel economy improvements compared to fuel cell vehicle without energy storages. Fuel cell vehicles with ultracapacitors connected directly in parallel with fuel cells achieved the highest fuel economy improvement due to elimination of losses in the DC/DC converter. However, compared to fuel cell vehicles without power electronics, fuel cell vehicles having power

electronics can maximize the utilization of the energy stored in the energy storages and load-level the fuel cell current to the largest extent.

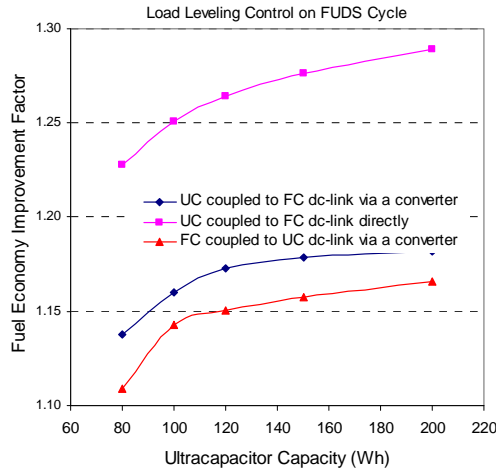

Figure 6 Fuel economy improvements of different fuel cell-ultracapacitor hybrids (relative to fuel cell vehicles without energy storages)

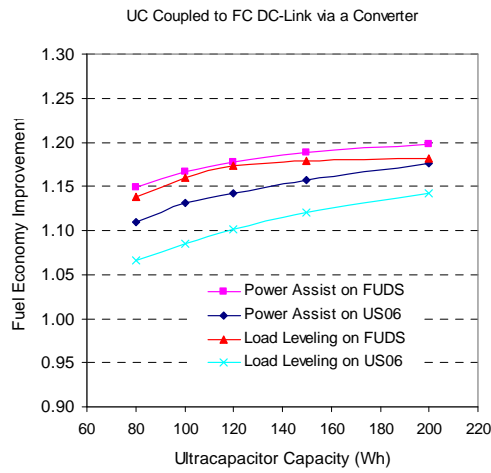

Figure 7 Fuel economy improvements of fuel cell-ultracapacitor hybrid vehicles

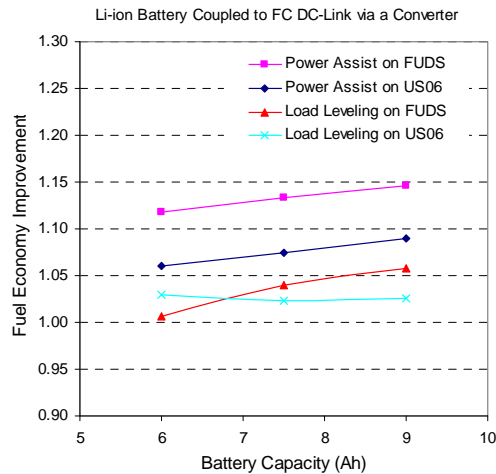

Figure 8 Fuel economy improvements of fuel cell-battery hybrid vehicles

Fuel cell vehicle having ultracapacitors and batteries coupled to the fuel cell DC link via power electronics were simulated with power-assist and load-leveling control. Figure 7 and Figure 8 show the fuel economy improvement for fuel cell-ultracapacitor hybrids and fuel cell-battery hybrids with different sizes of ultracapacitors and batteries, respectively. The improvements in fuel economy are relatively small being in the range of 7-20% for ultracapacitor hybrids and of up to 15% for battery hybrids with the improvements being larger for the FUDS cycle than for the US06 cycle. Compared to the load-leveling strategy, power-assist strategy results in larger improvements in fuel economy due to lower losses in the interface electronics and energy storage units. The fuel economy improvements are greater using ultracapacitors than batteries on both driving cycles. In addition, the effect of the control strategy on the fuel economy improvement is considerably less using ultracapacitors than using batteries. For both energy storage technologies, the improvement increases as the size of the energy storage unit is increased.

The fuel cell vehicle simulation results indicate that utilizing ultracapacitors coupled with fuel cells via a DC/DC converter with the load-leveling control strategy is the best approach for improving fuel economy and mitigating the stress on the fuel cell. The power-assist control strategy is well suited for fuel cell-battery hybrids in terms of fuel economy improvement.

4 Comparison of Fuel Economy of Future Vehicle Technologies

As one of future vehicle technologies, fuel cell vehicles with different drive train configurations were analyzed in terms of fuel economy. It's also interested to compare fuel cell vehicles and other future vehicles with today's conventional vehicles in the market in terms of how well they promise to meet important objectives for the transportation system of the future. Computer simulations of the operation of midsize passenger cars were performed for fuel cell-battery hybrid vehicles, hybrid electric vehicles, and advanced conventional internal combustion engine vehicles at three points in the future: 2015, 2030, and 2045 to compare how much each technology promises to trim fuel consumption.

The fuel cell hybrid electric vehicles (FCHEVs) used for comparison with other vehicle technologies are fuel cell-battery hybrid with the lithium ion battery connected to the fuel cell bus by a DC/DC converter. The converter controls the output power of the battery such that the output power of the fuel cell is load-leveled. The peak efficiency of the fuel cell is increased in future years. The engines used in the simulations of hybrid electric vehicles and conventional ICE vehicles are spark-ignition engines. The maximum engine efficiencies are increased in the simulation for future years based on expected significant improvements in engine efficiencies using upcoming technologies. The batteries used in the simulations of HEVs and FCHEVs are scaled from Lithium Titanate batteries as shown in Table 2. The most important and uncertain inputs used in the simulations are the vehicle characteristics — vehicle weight and road load characteristics: drag coefficient, frontal area, and tire rolling resistance. The values used are the same as assumed in S. Plotkin and M. Singh, — Multi-Path Transportation Futures Study: Vehicle Characterization and Scenarios, Argonne Lab and DOE Report.

Table 2 Battery Characteristics

Year	Battery Type	Ah	Wh/kg	Resistance mOhm
2015	Lithium Titanate	4	35	1.1
2030/2045	Lithium Titanate	4	42	0.9

Table 3 Fuel economy projection for midsize fuel cell-battery hybrid passenger cars

	2015		2030		2045	
	UCD	DOE	UCD	DOE	UCD	DOE
FUDES	82.6	70	102.8	102	108.9	114
HWY	90.8	79	111.5	114	119.5	130
US06	61.3	--	76.2	--	82.3	--
Vehicle Configuration	2015		2030		2045	
C_D	.25		.22		.2	
A_F (m ²)	2.2		2.2		2.2	
Fr	.007		.006		.006	
FC (kW)	83.2		76.6		72.1	
Fuel cell efficiency %	60		62		65	
Motor (kW)	103		100		99	
Battery (kWh)	.93		.85		.85	
Vehicle Test Weight (kg)	1516		1383		1366	
Elec. Acc Load (W)	220		240		260	

Simulations of fuel cell-battery hybrid vehicles were performed over the FUDES, HWY, and US06 driving cycles for the year of 2015, 2030, and 2045. The simulation inputs and simulation results are shown in table 3 for midsize fuel cell hybrid passenger cars. The projected fuel economy and fuel savings over different driving cycles were plotted in Figure 9 and Figure 10. The simulation results indicate that large improvements in the fuel economy of midsize fuel cell-battery hybrid passenger cars can be expected in 2015 to 2030. Further improvements are projected for 2045. Compared to a midsize 2007 baseline passenger car these improvements are 60 percent (2015) to 70 percent (2045) for fuel savings. Simulation results previously published by the DOE [3] were also plotted in Figure 9 and Figure 10. Both UCD and DOE projections for fuel cell-battery hybrids are in good agreement over the complete time period of the simulations, with the agreement being closest in the 2030–2045 time periods. It should be noted that the vehicle characteristics used in the UC Davis simulations were selected to match those used in the DOE study. Hence the agreement between the two studies indicates consistency in the modeling approaches in the studies for the FCHEV technologies.

Studies directed toward projecting the performance of advanced ICE vehicles and hybrid electric vehicles were also performed by using the modified Advisor at the UC Davis. The projected fuel economies and fuel savings for advanced ICEs, HEVs and hybrid fuel cell-battery vehicles relative to a 2007 midsize conventional passenger car were plotted in Figure 11 and Figure 12, respectively. The simulations show that fuel cell vehicles achieve about twice the fuel economy of the improved conventional engine/transmission drive trains and only about 15 percent better economy compared to the HEV drive trains. This does not include a consideration of the differences in the efficiencies of producing gasoline from petroleum and hydrogen from natural gas or coal, however.

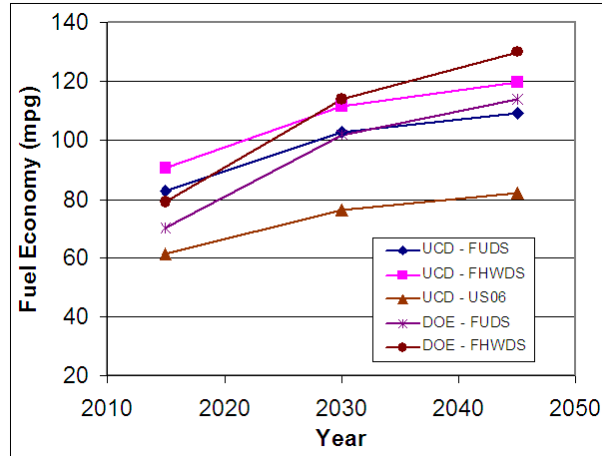

Figure 9 Fuel economy simulation results of different future vehicle technologies

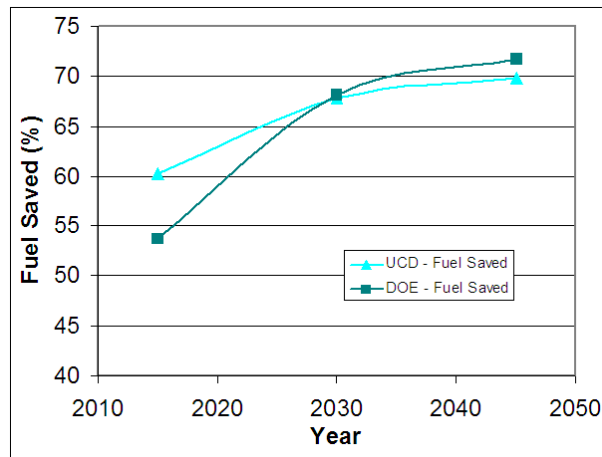

Figure 10 Fuel savings* of future vehicle technologies relative to 2007 passenger cars
 * % Fuel Saved = $(1 - \text{mpg}_0 / \text{mpg}) \times 100$, $\text{mpg}_0 = 34.5$, which is the average of the urban-highway dynamometer fuel economy of the 2007 baseline vehicle.

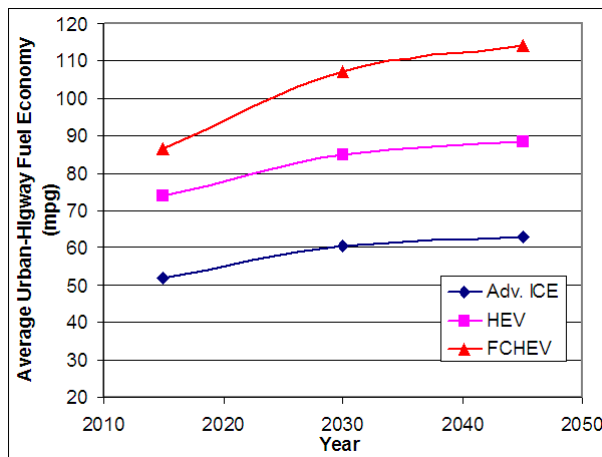

Figure 11 Comparison of fuel economies of different future vehicle technologies

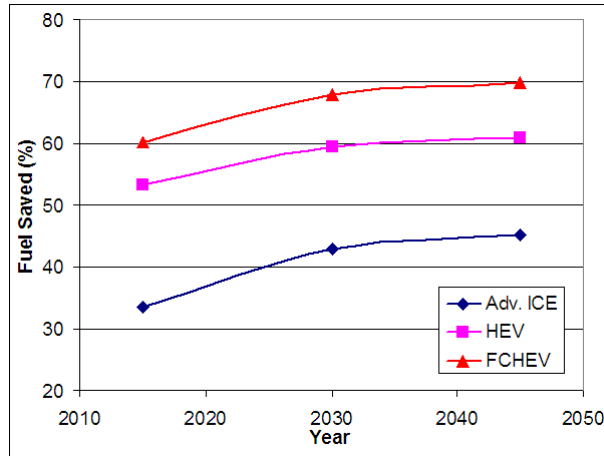

Figure 12 Comparison of fuel savings of different vehicle technologies

5 Summary and Conclusions

Fuel cell hybrid vehicles having different drive train configurations with different power splitting strategies and energy storages were studied. Fuel economy and fuel savings of a midsize fuel cell-battery hybrid vehicle were projected at three points in the future: 2015, 2030, and 2045. Simulation results show that fuel cell vehicles having ultracapacitors coupled with fuel cells via a DC/DC converter with load-leveling control is the best approach in term of improving fuel economy and mitigating the stress on the fuel cell. Power-assist control is well suited for fuel cell-battery hybrids in terms of fuel economy improvement. Fuel cell-battery hybrid vehicles achieve about twice the fuel economy of the improved conventional engine/transmission drive trains and only about 15 percent better economy compared to the HEV drive trains.

Reference:

- [1] J. Bauman and M. Kazerani: "A Comparative Study of Fuel-Cell–Battery, Fuel-Cell–Ultracapacitor, and Fuel-Cell–Battery–Ultracapacitor Vehicles", *IEEE Transaction on Vehicular Technology*, 57(2) 2008
- [2] H. Zhao and A.F. Burke: "Fuel Cell Powered Vehicles Using Ultracapacitors -- Device Characteristics, Control Strategies, and Simulation Results", *Journal of Fuel Cells*, 10(5) 2010
- [3] S. Plotkin and M. Singh: "Multi-Path Transportation Futures Study: Vehicle Characterization and Scenarios", Argonne Lab and DOE Report (draft), 2009
- [4] H. Zhao and A. F. Burke: "Optimization of Fuel Cell System Operating Conditions for Fuel Cell Vehicles", *Journal of Power Sources* 186, 2009