

UC Merced

Proceedings of the Annual Meeting of the Cognitive Science Society

Title

Decentering Cognition

Permalink

<https://escholarship.org/uc/item/9gm3p6qr>

Journal

Proceedings of the Annual Meeting of the Cognitive Science Society, 42(0)

Authors

Bechtel, William

Huang, Linus T.

Publication Date

2020

Peer reviewed

Decentering Cognition

William Bechtel (wbechtel@ucsd.edu)

Department of Philosophy, University of California, San Diego
La Jolla, CA 92093-0119

Linus T. Huang (linushuang@ucsd.edu)

Department of Philosophy, University of California, San Diego
La Jolla, CA 92093-0119
Institute of European and American Studies, Academia Sinica
Taipei 11529, Taiwan

Abstract

The neocortex figures importantly in human cognition, but it is not the only locus of cognitive activities or even at the top of a hierarchy of cognitive processing areas in the central nervous system. Moreover, the form of information processing employed in the neocortex is not representative of information processing elsewhere in the nervous system. In this paper, we articulate and argue against cortico-centrism in cognitive science, contending instead that the nervous system constitutes a heterarchical network of diverse types of information processing systems. To press this perspective, we examine neural information processing in both non-vertebrates and vertebrates, including examples of cognitive processing in the vertebrate hypothalamus and basal ganglia.

Keywords: basal ganglia; cortico-centrism; heterarchical organization; hypothalamus; neuromodulators; neuropeptides

1. Introduction

The neocortex is often viewed as the locus of cognitive activities. To many cognitive scientists, this cortico-centric view of cognition seems just obvious. The cortex is the locus to which the senses project information and from which motor commands originate. Cognition is understood as what occurs between these inputs and outputs as information is processed through a sequence of cortical areas until decisions are made in executive regions in the prefrontal cortex and commands issued to motor regions of cortex. (In recent years, some cognitive theorists have expanded their focus beyond the neocortex to include the loops linking cortex with the thalamus and basal ganglia. Even for these theorists, the cortex remains central.) We call this view *cortico-centrism*. We challenge the assumption that cognition is exclusively a feature of the neocortex. We focus on two features of cortical processing: *restricted synaptic transmission* and *hierarchical structure*, which are not shared by other brain regions which, we contend, play important roles in cognition.

Signals are transmitted between cortical neurons primarily through neurotransmitters such as GABA and glutamate. What is characteristic of neurotransmitters is that they operate within a synapse: they are transported, typically in small vesicles, to the presynaptic terminal from which they

are released into the synaptic cleft. Some molecules bind to receptors on the postsynaptic neuron and those that do not are quickly removed from the synaptic cleft. As a result, synaptic information transmission tends to be highly specific on temporal and spatial scales. However, outside neocortex, many neurons communicate with volume transmitters (dopamine, serotonin, histamine, etc.) or neuropeptides (small molecules released from nerve cells which mostly act on G-protein coupled receptors). These are often released in large vesicles at locations other than synapses, including in the cell body. They are not broken down at the site but diffuse through cerebral spinal fluid or the circulatory system and affect the activity of many neurons and other cells that have receptors to which they can bind. Thus, information transmitted through volume transmitters and neuropeptides is much less specific on both temporal and spatial scales. These molecules often bind to neurons that also communicate using traditional neurotransmitters. In these cases, they modify the excitability, synaptic efficiency, and dynamics of the target neurons and alter the cognitive processing of the circuit in which these neurons are situated. Accordingly, they are characterized as neuromodulators. Thus, the first focus of cortico-centrism, restricted synaptic transmission, refers to the tendency to overemphasize the roles of neurotransmitters over neuromodulators in information processing.

The second focus, hierarchical structure, limits one's focus to one type of cognitive architecture as responsible for processing information, one in which neurons in layers are organized topographically and projections between layers link sensory processing regions to higher "cognitive" areas, and then down to motor areas. (In recent years, researchers have recognized the bidirectional flow of information as well as the direct connections between sensory and motor areas, but still accommodate these extensions within the hierarchical picture.) To a reasonable approximation, the focus on hierarchical structure fits the neocortex. However, it does not characterize other brain regions that consist of nuclei of neurons that reside in distributed networks in which they integrate inputs from and transmit outputs to a broad range of other nuclei. We use the term *heterarchical*¹ for organization

¹ The notion of heterarchy was introduced by McCulloch (1945) for non-hierarchical relations between values. We extend it to organization more generally.

that deviates substantially from hierarchy (e.g., by having multiple control mechanisms operating semi-independently on a given controlled mechanism, communicating in a variety of ways, and lacking a single highest-level controller).

Both synaptic transmission and hierarchical structure are illustrated in many artificial neural networks. Such networks are hierarchical, processing input through a sequence of layers until outputs are generated. The connections between nodes resemble synaptic transmission and are often the only kind of information flow in the network. Finally, we note that the second focus is also strengthened by the first one: by foregrounding connections based on neurotransmitters (and backgrounding all others), the hierarchical structure in the cortex seems much more compelling. Volume transmitters, in contrast, are less likely to conform to hierarchical organization.

To show the limits of cortico-centrism, we situate cognition within the context of basic information processing all organisms must perform. As highly organized systems, all organisms are far from equilibrium with their environments. To maintain themselves, they must procure energy and material resources while avoiding destructive forces in their environments (Moreno & Mossio, 2014). To carry out these activities as needed, they must control the production mechanisms that perform them. Control mechanisms require information either about the state of the organism or features of its environment (Bechtel, 2019; Wining & Bechtel, 2018). Accordingly, information processing activities—perceiving, categorizing, decision making, coordinating motor responses etc.—are activities all organisms must perform to maintain themselves. A phylogenetic perspective reveals how multiple, partly independent information processing activities developed, taking advantage of chemical processes within cells. Although these activities are especially important in prokaryotes, plants, fungi, and animals lacking neurons,² we limit our focus here to animals with neurons.

Adopting phylogenetic perspective helps to illustrate the range of cognitive activities organisms perform. We begin in section 2 with Cnidarians, and in section 3 consider *C. elegans*. Similar activities are performed in vertebrates, but often in areas outside the neocortex. In sections 4 and 5 we focus on two structures outside of cortex that perform important cognitive functions in all vertebrates—the hypothalamus and the basal ganglia. We conclude by considering the implications of adopting a decentered perspective that emphasizes cognitive processes in multiple areas of the brain for cognitive science.

2. Decentered Cognition in Cnidarians

Cnidarians (jellyfish and polyps) branched off from other animal species very early³ and provide a glimpse into one of

² *Trichoplax adhaerens* provides a useful model of an animal without neurons. It has most of the components that in subsequent evolution were packaged into neurons, including a number of peptides. It has only six types of cells, whose activities are coordinated. Senatore, Reese, and Smith (2017) identified

the earliest nervous systems. The core part of the nervous system in Cnidarians is a nerve net that lies between two layers of contractile cells—epidermis and gastrodermis—that constitute the bell. The nerve net includes what have been identified as sensory and motor neurons that together coordinate the contractions of epidermal cells (Keijzer, van Duijn, & Lyon, 2013). The nerves whose processes cross each other in the nerve net communicate bidirectionally by releasing neuropeptides that gate ion channels in the other neuron, altering its electrical activity (Golubovic et al., 2007; Grunder & Assmann, 2015).

The nerve net provides an information processing backbone that coordinates contractile activity but is subject to modulation by other neurons that project onto it. There are two rings of neurons surrounding the bell. Neurons in the inner ring act as pacemakers, creating a rhythmic pattern that regulates activity in the nerve net and, consequently, contraction of the bell during swimming. Signaling from elsewhere in the organism serves to alter the pacemaker and hence swimming (Meech, 2019). For example, when a threat is detected (e.g., by contact with the tentacles), it induces larger contractions, leading to escape swimming. When the jellyfish is eating, neural signals halt the pacemaker (presumably to avoid dislodging the food). Often this information is conveyed chemically, leading Bosch et al. (2017) to claim “that the cnidarian nerve net, while structurally simple, is chemically complex” and to propose that it might rely on a “chemical connectome” in which it is not the specific set of synapses that determines activity, but the distinctive receptors that respond to transmitter substances that are distributed widely.

In short, Cnidarian nervous systems illustrate that the features we associate with cortico-centrism are not universal. Cnidarians neither exhibit hierarchical structure nor rely exclusively on synaptic transmission for producing adaptive behaviors. Yet they process information needed to regulate their behaviors appropriately given environmental and internal circumstances.

3. Decentered Cognition in *C. elegans*

As the first organism for which researchers generated a nearly complete connectome (White, 1985; White, Southgate, Thomson, & Brenner, 1986; for a more recent update, see Varshney, Chen, Paniagua, Hall, & Chklovskii, 2011), the round worm *C. elegans* has provided a model organism for determining how a nervous system supports different behaviors. Based on the connectome, researchers were able to identify different circuits that respond to different signals and activate different behaviors. For example, in conjunction with the research on the connectome, Chalfie et al. (1985) characterized a circuit controlling backwards and forwards locomotion in response to a light touch to the head or tail

endomorphin-like peptides released by sensory cilia that function to arrest beating of motor cilia during feeding. The endomorphin-like peptides also facilitate communication between organisms.

³ There is a debate as to whether Ctenophora branched earlier, perhaps even before Porifera (Kristan, 2016).

(Figure 1). The sensory neuron for posterior touch, PLM, is connected by both chemical synapses and gap junctions (which connect the cytoplasm of two cells directly) to PVC, which sends excitatory connections to the motor neurons required for accelerating forward motion. In a similar way, anterior touch results in reversal and backward movement. This circuit became the model of other networks involved in chemotaxis, foraging, feeding, egg-laying, etc. in *C. elegans*.

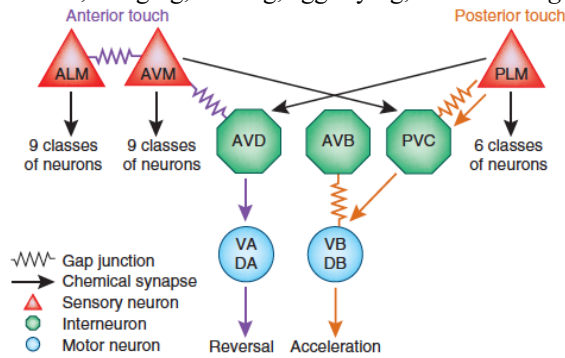

Figure 1. Circuit controlling forwards (Acceleration) and backward (Reversal) locomotion in *C. elegans*. From (Bargmann & Marder, 2013)

These distinct circuits show that *C. elegans* employs a highly decentered, heterarchical cognitive system in which distinct neural mechanisms acquire, process, and utilize information for each of the worm's activities. Subsequent studies revealed ways in which these circuits coordinate through a complex network of interneurons, many of which generate volume transmitters and neuromodulators that modify the behavior of individual circuits. For example, while only one neuron is able initiate an avoidance response to the repulsive odor of octanol when the worm is well-fed, a diverse set of sensory neurons can do so when it is starved. This change can be induced experimentally by the application of exogenous serotonin, known to be associated with food-related behaviors (Chao, Komatsu, Fukuto, Dionne, & Hart, 2004). Subsequent research revealed that other amines—dopamine, tyramine, octopamine—as well as neuropeptides, released by a variety of different neurons, can also modulate the activity of the network (Wragg et al., 2007; Mills et al., 2012). Bargmann (2012) concludes from these and similar findings that “information flow through *C. elegans* circuits depends on neuromodulatory states.” (p. 461).

C. elegans employs multiple different control mechanisms to acquire and process information appropriately so as to behave as needed to maintain itself. These constitute a decentered, heterarchical system that relies extensively on neuromodulators to coordinate multiple control mechanisms.

4. Decentered Cognition in Vertebrates: The Hypothalamus

One might reject appeals to Cnidarians and *C. elegans* as supporting objections to cortico-centrism since such creatures do not even have a centralized brain, let alone a neocortex. We started with these examples because they illustrate principles, heterarchy and chemical modulation,

that figure also in vertebrate cognition. We now turn to vertebrates and, in this section and the next, offer evidence that differences between invertebrates and vertebrates are exaggerated. The vertebrate brain also contains multiple distinct processing areas that figure importantly in cognitive activities. Many of these do not exhibit the two features of cortico-centrism but rather heterarchical organization and chemical modulation.

An important finding in recent years is that the basic plan of the vertebrate brain is highly conserved. Regions have expanded differentially; in particular, the small pallium of the first vertebrates has expanded into the massive neocortex of humans (as well as the hippocampus and related structures). But structures such as the hypothalamus, basal ganglia, thalamus, and cerebellum were all present in the common ancestor of vertebrates (Grillner & Robertson, 2016). These and other structures play important roles in cortical information processing. But what is especially notable is that they are adequate to generate much of the characteristic behavior of animals, as was revealed by research on decorticate animals (primarily cats) in the second half of the 20th century (Bjursten, Norrsell, & Norrsell, 1976). As long as both the thalamus and basal ganglia were preserved, cats could live for years in the laboratory, processing the information needed to perform their daily activities.

We start with the hypothalamus, which processes information important for many behaviors, including eating, reproducing, and responding to threats. By regulating sleep and alertness, it also modulates processing in the neocortex. Notably, however, it is organized in a radically different manner than the neocortex. Rather than employing the two features of restricted synaptic transmission and hierarchical structure, the hypothalamus exercises control over behavior and other brain through “hundreds, perhaps thousands of chemically, connectionally, and functionally distinct cell populations” (Saper & Lowell, 2014). These different populations respond to different information about the state of the organism and send out regulatory signals that modulate physiological and motor systems.

To illustrate the type of regulation performed by the different nuclei of the hypothalamus, we focus on just one example, the regulation of arousal by the hypocretin/orexin system. When hypocretin neurons were first identified (de Lecea et al., 1998; Sakurai et al., 1998), they were characterized as promoting eating behavior. Although they do figure in control of eating, a variety of studies soon pointed to a large effect on overall arousal. Recording from these neurons revealed that they fire maximally 10-20 seconds prior to a sleep-to-wake transition (Lee, Hassani, & Jones, 2005), while optogenetic activation of these neurons can promote wakefulness (Adamantidis, Zhang, Aravanis, Deisseroth, & de Lecea, 2007). Silencing these neurons, in contrast, induces slow-wave sleep (Tsunematsu et al., 2013).

An important feature of these neurons is that they project to and release hypocretin in many brain regions which have also been implicated in arousal (Figure 2). For example, they project to the locus coeruleus where experimental

administration of hypocretin promotes arousal (Gompf & Aston-Jones, 2008). Silencing hypocretin release in the locus coeruleus prevents sleep-to-wake transitions. (The locus coeruleus, in turn, is a primary source of cortical noradrenaline—a neuromodulator involved in promoting wakeful processing in the neocortex.) Other loci to which hypocretin neurons project are the dorsal raphe nuclei and the ventral periaqueductal gray, which contain serotonin and dopamine neurons whose activations generate the rapid transition from sleep to wakefulness (Moriya et al., 2017; Cho et al., 2017). Another dopaminergic center to which the hypocretin cells project is the ventral tegmental area (VTA). Although not traditionally linked to arousal, dopamine neurons in the VTA have now been implicated in wakefulness (Eban-Rothschild, Rothschild, Giardino, Jones, & de Lecea, 2016).

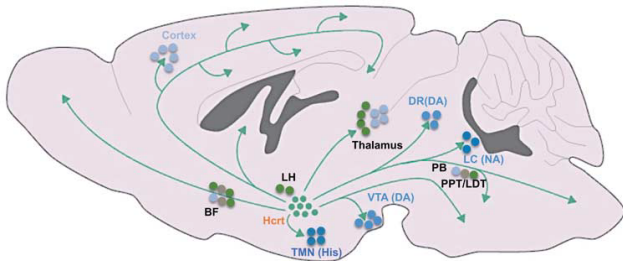

Figure 2 Projections in the rat brain from hypocretin neurons in the thalamus. Figure from Eban-Rothschild, Appelbaum, and de Lecea (2018).

We return to the VTA below, but to flesh out the picture of how hypocretin neurons process information, it is important to realize that they not only project broadly but receive input from multiple locations. Using retrograde tracers, Yoshida, McCormack, Espana, Crocker, and Scammell (2006) identified projections into regions containing hypocretin neurons from allocortex, claustrum, lateral septum, bed nucleus of the stria terminalis, many hypothalamic regions (e.g., the preoptic area, dorsomedial nucleus, lateral hypothalamus, posterior hypothalamus), as well as various brainstem regions (e.g., the periaqueductal gray, dorsal raphe nucleus, and lateral parabrachial nucleus). Inputs from the amygdala and bed nucleus of the stria terminali to the hypocretin neurons suggest how emotional states can affect arousal and the sleep-wake cycle. Inputs from the suprachiasmatic nucleus, primarily relayed via the subparaventricular zone and dorsomedial nucleus, are of particular significance since they carry information about circadian time that figures in maintenance of sleep.

A variety of hormones also affect the activity of hypocretin neurons. Leptin, which is secreted by adipocytes and correlates with satiety, inhibits hypocretin neurons. When leptin levels are reduced during fasting, hypocretin neurons increase activity and promote wakefulness (Leininger et al., 2011). Likewise, ghrelin increases during fasting and also generates increased hypocretin activity. Relatedly, ghrelin itself generates feeding, but this can be blocked by attenuating hypocretin signaling (So et al., 2018). As a final example, there is a positive feedback loop between stress and hypocretin activity: stress activates hypocretin neurons

(Winsky-Sommerer, Boutrel, & de Lecea, 2005), while hypocretin activity, in turn, results in subsequent increase in circulating glucocorticoids (Bonnayon, Jackson, Carter, & de Lecea, 2015).

The picture that emerges is that hypocretin neurons regulate other brain and behavioral centers based on integrating information carried by a rich array of volume transmitters and neurotransmitters from a variety of sources relevant to the need for arousal. Hypocretin neurons are just one example of hypothalamic neurons that process information and regulate behavior but employ design principles very different than that of neocortex.

5. Decentered Cognition in Vertebrates: The Basal Ganglia

One may object that most of the behaviors regulated by the hypothalamus are not particularly “cognitive” and that it is cognitive behaviors, such as deliberate decisions, that are distinctively human and of principle interest to cognitive science. It is these activities that are dependent on the cortex and its restricted synaptic transmission and hierarchical organization. We argue that cortico-centrism is false even for high-level cognition by turning to our second example of non-cortical mechanisms in the vertebrate brain, the basal ganglia. The basal ganglia are a connected set of subcortical nuclei that have been identified as playing important roles in a variety of functions, such as sensorimotor processing, motivated behavior, reward learning, and “cognitive” activities of working memory, model-based planning, and attention.

One distinctive feature of the basal ganglia that places them outside the cortical hierarchy is that they receive inputs from and send outputs to an extraordinary number of other brain regions, including sensorimotor, associative, and motivational areas of the cortex, as well as non-cortical areas such as motor command regions in the midbrain (Figure 3). In many cases, the inputs and outputs form loops through which the basal ganglia affect the same areas from which they receive inputs.

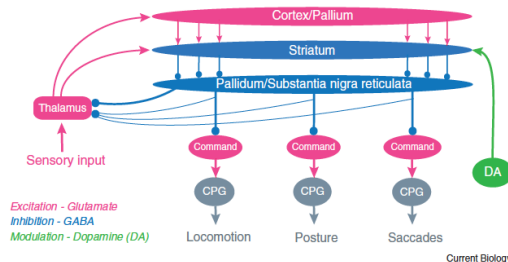

Figure 3. Common organization of inputs into and outputs from the striatum (shown in blue) in vertebrate brains.

Figure from Grillner and Robertson (2016).

Another feature is that the basal ganglia exhibit a *heterarchical* internal organization that enables them to play crucial roles in the selection of internal and external responses. Here, we present a simplified picture to illustrate how the organization serves this function (Figure 4).

Different neurons in the input nuclei, known collectively as the striatum, project along one of two pathways to the output nuclei, the substantia nigra pars reticulata and the globus pallidus internus. The default activity of the output nuclei is to inhibit other brain regions, such as those shown in Figure 3. Projections along what is known as the direct pathway serve to reduce this inhibition, allowing these other brain regions to carry out their activity, while projections along the indirect pathway serve to enhance the inhibition of these regions. Whether the direct or the indirect pathway is favored, leading to release or further inhibition of the target regions, depends on which neurons in the striatum receive the stronger inputs. There is yet a third pathway, known as the *hyperdirect pathway* that generates an overall stimulation to the output nuclei and thereby raises the threshold that the direct pathway must overcome to release target areas from inhibition. By determining which areas are released from tonic inhibition, the basal ganglia select internal and external responses, including working memory updates, attentional shifts, and motor behaviors.

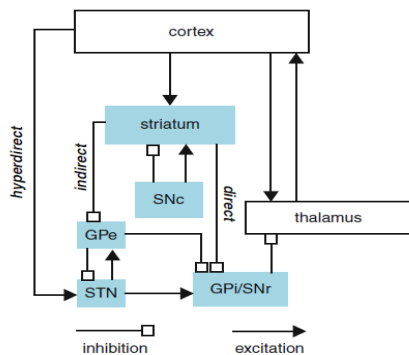

Figure 4. Major structures and pathways of the basal ganglia. Figure from Rubin (2015).

The activity of basal ganglia is not limited to response selection, itself an important cognitive activity; it also figures in other cognitive activities such as reward learning, habit formation, and sequence learning. In a particular striking example, Redgrave et al. (2010) provide evidence that competition between inputs from associative areas of cortex and prefrontal cortex is involved in switching from automatic, habitual processing to controlled, goal-directed processing.

The basal ganglia are not organized hierarchically, nor are they situated in the hierarchy of cortical areas. Moreover, volume transmitters are essential for implementing the relevant information processing in the basal ganglia. Dopamine, shown as DA in Figure 3, is an important input to the striatum; dopaminergic neurons that project into the striatum arise in the VTA and the substantia nigra pars compactus. Dopamine, like other volume transmitters, disperses broadly from the cells that synthesize it and, by binding to receptors on other neurons, acts as a modulator on their activity. Indeed, the importance of the basal ganglia in the ability to initiate voluntary movement was first recognized in Parkinson's patients, whose dopamine levels are significantly reduced. The striatal neurons that are the origin of the direct and indirect pathways are distinguished

by different dopamine receptors. Dopamine increases the response of neurons in the direct pathway; accordingly, reduced dopamine impairs the ability of this pathway to overcome the tonic inhibition of the output regions of the basal ganglia.

Dopamine signaling in the basal ganglia plays several important roles. In particular, phasic release of dopamine provides the reward signal that supports reinforcement learning which enables the basal ganglia not just to make selections but to learn to make better selections. A phasic increase in dopamine concentration results in greater responsiveness of the direct pathway, enhancing the likelihood of a similar response in the future, while a phasic reduction increases the responsiveness of the indirect pathway, making the response less likely.

Adopting a comparative perspective, Hills (2006) advanced the hypothesis that tonic dopamine levels play a role in regulating explorative vs. exploitive behaviors in multiple domains. We noted in section 3 that in *C. elegans* dopamine acts as a modulator in the circuit for forward and backward movement. Hills, Brockie, and Maricq (2004) further showed that dopamine release in *C. elegans* leads to more turning, hence more investigation of the local area (exploitive behavior). Administration of a dopamine agonist, or ablation of the dopaminergic neurons, stops local search and results in the worm moving on to other locations (explorative behavior). Drawing upon this suggested role in regulating search in physical space, Hills et al. (2015) argue for the role of dopamine in regulating search in more cognitive domains such as memory and problem solving. The basal ganglia are one locus of this regulation. Low tonic dopamine levels result in oscillatory activity in the indirect pathway, resulting in more random variation in which inputs to the striatum are selected (explorative behavior). High tonic dopamine levels, in contrast, decrease the oscillation, limiting the output to the strongest input (exploitive behavior).

Although our discussion is deliberately simplified (see Huang, 2017 for a philosophically-oriented overview), it reveals the basal ganglia to rely on volume transmitters and to be organized heterarchically, not hierarchically. While not fitting the cortico-centric perspective on information processing, they are nonetheless crucial for controlling behavior and high-level cognition.

Implications of Decentering the Brain

We have advanced examples from both non-vertebrates and vertebrates that reveal neural information processing very different from that performed in the neocortex. Unlike neocortex, much of this processing involves peptidergic and volume transmitters that behave differently than classical neural transmitters. Moreover, it occurs in heterarchically-structured networks. We have focused on two examples of structures in vertebrate brains that differ from cortex in these respects and play important roles in determining behavior. There are numerous others, such as the superior colliculus, cerebellum and the thalamus, that could have been used to further illustrate our thesis. The upshot is that the vertebrate

brain contains a large variety of neural processing systems that cannot be characterized by cortico-centrism.

The implications for cognitive science are two-fold. First, there are many other activities in the brain that are involved in processing information and regulating behavior. Many of these are commonly characterized in cognitive vocabulary and are performed independently of the neocortex. Rather than focusing on one central cognitive system, cognitive scientists should recognize that there are numerous different systems that each carry out specialized information processing tasks. Second, these systems employ architectures for processing information quite different from that provided by the cortex. Employing an artificial neural network as a model for all cognitive tasks may lead to misrepresenting how the brain performs cognitive activities. This is not to deny the significance of neocortical processing, but to contextualize it within a larger cognitive system. Once one does so, one can investigate the types of information processing it supports, and thus its distinctive contributions to our cognitive activities, while also recognizing that information processing in neocortex represents only one form of information processing important for cognition.

Acknowledgment

This work is supported in part by a fellowship to Dr. Linus Ta-Lun Huang, sponsored by Academia Sinica, Taiwan.

References

- Adamantidis, A. R., Zhang, F., Aravanis, A. M., Deisseroth, K., & de Lecea, L. (2007). Neural substrates of awakening probed with optogenetic control of hypocretin neurons. *Nature*, *450*(7168), 420-424. doi:10.1038/nature06310
- Bargmann, C. I. (2012). Beyond the connectome: How neuromodulators shape neural circuits. *BioEssays*, *34*(6), 458-465. doi:10.1002/Bies.201100185
- Bargmann, C. I., & Marder, E. (2013). From the connectome to brain function. *Nature methods*, *10*(6), 483-490. doi:10.1038/Nmeth.2451
- Bechtel, W. (2019). Resituating cognitive mechanisms within heterarchical networks controlling physiology and behavior. *Theory & Psychology*, *29*(5), 620-639. doi:10.1177/0959354319873725
- Bjursten, L. M., Norrsell, K., & Norrsell, U. (1976). Behavioural repertory of cats without cerebral cortex from infancy. *Experimental Brain Research*, *25*(2), 115-130. doi:10.1007/BF00234897
- Bonnavion, P., Jackson, A. C., Carter, M. E., & de Lecea, L. (2015). Antagonistic interplay between hypocretin and leptin in the lateral hypothalamus regulates stress responses. *Nature Communications*, *6*(1), 6266. doi:10.1038/ncomms7266
- Bosch, T. C. G., Klimovich, A., Domazet-Lošo, T., Gründer, S., Holstein, T. W., Jékely, G., . . . Yuste, R. (2017). Back to the Basics: Cnidarians Start to Fire. *Trends in Neurosciences*, *40*(2), 92-105. doi:https://doi.org/10.1016/j.tins.2016.11.005
- Chalfie, M., Sulston, J. E., White, J. G., Southgate, E., Thomson, J. N., & Brenner, S. (1985). The neural circuit for touch sensitivity in *Caenorhabditis elegans*. *Journal of Neuroscience*, *5*(4), 956-964.
- Chao, M. Y., Komatsu, H., Fukuto, H. S., Dionne, H. M., & Hart, A. C. (2004). Feeding status and serotonin rapidly and reversibly modulate a *Caenorhabditis elegans* chemosensory circuit. *Proceedings of the National Academy of Sciences of the United States of America*, *101*(43), 15512.
- Cho, J. R., Treweek, J. B., Robinson, J. E., Xiao, C., Bremner, L. R., Greenbaum, A., & Gradinaru, V. (2017). Dorsal Raphe Dopamine Neurons Modulate Arousal and Promote Wakefulness by Salient Stimuli. *Neuron*, *94*(6), 1205-1219. doi:10.1016/j.neuron.2017.05.020
- de Lecea, L., Kilduff, T. S., Peyron, C., Gao, X. B., Foye, P. E., Danielson, P. E., . . . Sutcliffe, J. G. (1998). The hypocretins: Hypothalamus-specific peptides with neuroexcitatory activity. *Proceedings of the National Academy of Sciences of the United States of America*, *95*(1), 322-327.
- Eban-Rothschild, A., Appelbaum, L., & de Lecea, L. (2018). Neuronal Mechanisms for Sleep/Wake Regulation and Modulatory Drive. *Neuropsychopharmacology*, *43*(5), 937-952. doi:10.1038/npp.2017.294
- Eban-Rothschild, A., Rothschild, G., Giardino, W. J., Jones, J. R., & de Lecea, L. (2016). VTA dopaminergic neurons regulate ethologically relevant sleep-wake behaviors. *Nature Neuroscience*, *19*(10), 1356-1366. doi:10.1038/nn.4377
- Golubovic, A., Kuhn, A., Williamson, M., Kalbacher, H., Holstein, T. W., Grimmelikhuijzen, C. J., & Grunder, S. (2007). A peptide-gated ion channel from the freshwater polyp Hydra. *Journal of Biological Chemistry*, *282*(48), 35098-35103. doi:10.1074/jbc.M706849200
- Gompf, H. S., & Aston-Jones, G. (2008). Role of orexin input in the diurnal rhythm of locus coeruleus impulse activity. *Brain Research*, *1224*, 43-52. doi:10.1016/j.brainres.2008.05.060
- Grillner, S., & Robertson, B. (2016). The Basal Ganglia Over 500 Million Years. *Current Biology*, *26*(20), R1088-R1100. doi:https://doi.org/10.1016/j.cub.2016.06.041
- Grunder, S., & Assmann, M. (2015). Peptide-gated ion channels and the simple nervous system of Hydra. *Journal of Experimental Biology*, *218*(Pt 4), 551-561. doi:10.1242/jeb.111666
- Hills, T. T. (2006). Animal foraging and the evolution of goal-directed cognition. *Cognitive Science*, *30*(1), 3-41. doi:10.1207/s15516709cog0000_50
- Hills, T. T., Brockie, P. J., & Maricq, A. V. (2004). Dopamine and Glutamate Control Area-Restricted Search Behavior in *Caenorhabditis elegans*. *The Journal of Neuroscience*, *24*(5), 1217. doi:10.1523/JNEUROSCI.1569-03.2004
- Hills, T. T., Todd, P. M., Lazer, D., Redish, A. D., Couzin, I. D., & Group, t. C. S. R. (2015). Exploration versus exploitation in space, mind, and society. *Trends in*

- Cognitive Science*, 19(1), 46-54. doi:10.1016/j.tics.2014.10.004
- Huang, L. T. (2017). *Neurodemocracy: Self-organization of the embodied mind* (Ph.D. dissertation), University of Sydney.
- Keijzer, F., van Duijn, M., & Lyon, P. (2013). What nervous systems do: early evolution, input-output, and the skin brain thesis. *Adaptive Behavior*, 21(2), 67-85. doi:doi.org/10.1177/1059712312465330
- Kristan, W. B. (2016). Early evolution of neurons. *Current Biology*, 26(20), R949-R954. doi:https://doi.org/10.1016/j.cub.2016.05.030
- Lee, M. G., Hassani, O. K., & Jones, B. E. (2005). Discharge of Identified Orexin/Hypocretin Neurons across the Sleep-Waking Cycle. *Journal of Neuroscience*, 25(28), 6716-6720. doi:10.1523/jneurosci.1887-05.2005
- Leininger, G. M., Opland, D. M., Jo, Y. H., Faouzi, M., Christensen, L., Cappellucci, L. A., . . . Myers, M. G., Jr. (2011). Leptin action via neurotensin neurons controls orexin, the mesolimbic dopamine system and energy balance. *Cell Metabolism*, 14(3), 313-323. doi:10.1016/j.cmet.2011.06.016
- McCulloch, W. S. (1945). A heterarchy of values determined by the topology of nervous nets. *The bulletin of mathematical biophysics*, 7(2), 89-93. doi:10.1007/BF02478457
- Meech, R. W. (2019). Electrophysiology and Behavior of Cnidarian Nervous Systems. In *Oxford Research Encyclopedia, Neuroscience*. Oxford: Oxford University Press.
- Mills, H., Wragg, R., Hapiak, V., Castelletto, M., Zahratka, J., Harris, G., . . . Komuniecki, R. (2012). Monoamines and neuropeptides interact to inhibit aversive behaviour in *Caenorhabditis elegans*. *EMBO Journal*, 31(3), 667-678. doi:10.1038/emboj.2011.422
- Moreno, A., & Mossio, M. (2014). *Biological autonomy: A philosophical and theoretical inquiry*. Dordrecht: Springer.
- Moriya, R., Kanamaru, M., Ookuma, N., Tanaka, K. F., Izumizaki, M., Onimaru, H., . . . Oshima, Y. (2017). The effect of activating serotonergic neurons in the dorsal raphe nucleus on control of vigilance state. *European Respiratory Journal*, 50. doi:10.1183/1393003.congress-2017.OA1753
- Redgrave, P., Rodriguez, M., Smith, Y., Rodriguez-Oroz, M. C., Lehericy, S., Bergman, H., . . . Obeso, J. A. (2010). Goal-directed and habitual control in the basal ganglia: implications for Parkinson's disease. *Nature Reviews Neuroscience*, 11, 760-772. doi:10.1038/nrn2915
- Rubin, J. (2015). Basal ganglia: Overview. In D. Jaeger & R. Jung (Eds.), *Encyclopedia of computational neuroscience* (pp. 3-7). New York: Springer.
- Sakurai, T., Amemiya, A., Ishii, M., Matsuzaki, I., Chemelli, R. M., Tanaka, H., . . . Yanagisawa, M. (1998). Orexins and Orexin Receptors: A Family of Hypothalamic Neuropeptides and G Protein-Coupled Receptors that Regulate Feeding Behavior. *Cell*, 92(4), 573-585.
- Saper, C. B., & Lowell, B. B. (2014). The hypothalamus. *Current Biology*, 24(23), R1111-R1116. doi:https://doi.org/10.1016/j.cub.2014.10.023
- Senatore, A., Reese, T. S., & Smith, C. L. (2017). Neuropeptidergic integration of behavior in *Trichoplax adhaerens*, an animal without synapses. *The Journal of Experimental Biology*, 220(18), 3381. doi:10.1242/jeb.162396
- So, M., Hashimoto, H., Saito, R., Yamamoto, Y., Motojima, Y., Ueno, H., . . . Ueta, Y. (2018). Inhibition of ghrelin-induced feeding in rats by pretreatment with a novel dual orexin receptor antagonist. *Journal of Physiological Sciences*, 68(2), 129-136. doi:10.1007/s12576-016-0517-5
- Tsunematsu, T., Tabuchi, S., Tanaka, K. F., Boyden, E. S., Tominaga, M., & Yamanaka, A. (2013). Long-lasting silencing of orexin/hypocretin neurons using archaerhodopsin induces slow-wave sleep in mice. *Behavioural Brain Research*, 255, 64-74. doi:https://doi.org/10.1016/j.bbr.2013.05.021
- Varshney, L. R., Chen, B. L., Paniagua, E., Hall, D. H., & Chklovskii, D. B. (2011). Structural properties of the *Caenorhabditis elegans* neuronal network. *PLoS Computational Biology*, 7(2), e1001066. doi:10.1371/journal.pcbi.1001066
- White, J. G. (1985). Neuronal connectivity in *Caenorhabditis elegans*. *Trends in Neurosciences*, 8, 277-283.
- White, J. G., Southgate, E., Thomson, J. N., & Brenner, S. (1986). The structure of the nervous system of the nematode *Caenorhabditis elegans*. *Philosophical Transactions of the Royal Society of London. B, Biological Sciences*, 314(1165), 1-340. doi:10.1098/rstb.1986.0056
- Winning, J., & Bechtel, W. (2018). Rethinking causality in neural mechanisms: Constraints and control. *Minds and Machines*, 28(2), 287-310.
- Winsky-Sommerer, R., Boutrel, B., & de Lecea, L. (2005). Stress and arousal. *Molecular Neurobiology*, 32(3), 285-294. doi:10.1385/MN:32:3:285
- Wragg, R. T., Hapiak, V., Miller, S. B., Harris, G. P., Gray, J., Komuniecki, P. R., & Komuniecki, R. W. (2007). Tyramine and octopamine independently inhibit serotonin-stimulated aversive behaviors in *Caenorhabditis elegans* through two novel amine receptors. *Journal of Neuroscience*, 27(49), 13402-13412. doi:10.1523/JNEUROSCI.3495-07.2007
- Yoshida, K., McCormack, S., Espana, R. A., Crocker, A., & Scammell, T. E. (2006). Afferents to the orexin neurons of the rat brain. *Journal of Comparative Neurology*, 494(5), 845-861. doi:10.1002/cne.20859