

Lawrence Berkeley National Laboratory

LBL Publications

Title

Chelation and Catalysis

Permalink

<https://escholarship.org/uc/item/9k708602>

Author

Calvin, Melvin

Publication Date

1953-07-01

UCRL 2254

UNCLASSIFIED

UNIVERSITY OF
CALIFORNIA

*Radiation
Laboratory*

TWO-WEEK LOAN COPY

*This is a Library Circulating Copy
which may be borrowed for two weeks.
For a personal retention copy, call
Tech. Info. Division, Ext. 5545*

BERKELEY, CALIFORNIA

DISCLAIMER

This document was prepared as an account of work sponsored by the United States Government. While this document is believed to contain correct information, neither the United States Government nor any agency thereof, nor the Regents of the University of California, nor any of their employees, makes any warranty, express or implied, or assumes any legal responsibility for the accuracy, completeness, or usefulness of any information, apparatus, product, or process disclosed, or represents that its use would not infringe privately owned rights. Reference herein to any specific commercial product, process, or service by its trade name, trademark, manufacturer, or otherwise, does not necessarily constitute or imply its endorsement, recommendation, or favoring by the United States Government or any agency thereof, or the Regents of the University of California. The views and opinions of authors expressed herein do not necessarily state or reflect those of the United States Government or any agency thereof or the Regents of the University of California.

UNIVERSITY OF CALIFORNIA

Radiation Laboratory

Contract No. W-7405-eng-48

CHELATION AND CATALYSIS

Melvin Calvin

July 10, 1953

Berkeley, California

CHELATION AND CATALYSIS*

Department of Chemistry and Radiation Laboratory,**
University of California, Berkeley, Calif.

Melvin Calvin

ABSTRACT

July 10, 1953

This constitutes a review of the general principles of chelation, approximately in the form that the principles were presented in detail in our monograph. In addition, these principles are then applied to a variety of catalytic phenomena in which chelation is known to play a part, or conceivably might play a part. The examples described are taken primarily from biochemistry, with a few examples from straight synthetic organic chemistry.

* This paper was presented in June, 1953 at a symposium on the "Mechanism of Enzyme Action," sponsored by the McCollum-Pratt Institute, Johns Hopkins University, Baltimore, Maryland. It is to be published in the proceedings of that symposium.

** This work was sponsored, in part, by the U.S. Atomic Energy Commission.

CHELATION AND CATALYSIS*

Melvin Calvin

Department of Chemistry and Radiation Laboratory,**
University of California,
Berkeley, California

Any examination of the nature of the substances which function as catalysts in biological transformations cannot fail to impress you with the fact that metals are obviously involved, and only a slightly closer examination brings out the rather pronounced fact that in those cases in which the nature of the combination of the metal has been determined, it is a chelate compound of some sort. It was this fact which, some fifteen years ago, first impressed me and resulted in the initiation of a series of studies, some of the results of which I would like to describe to you this afternoon.

First of all, it is necessary to define what we mean by the term "chelate." In Figure 1 we show diagrammatically that structural element for which the term chelate is used. In general, metal ions may be said to form complex compounds with a wide variety of ligands. The term ligand may be described as an atom or group of atoms which generally donate electrons to a separate metal atom, to form a more or less homopolar bond, as distinguished from purely coulombic interaction between ions, dipoles, or combinations of these. If two or more of these ligands are themselves tied together in some way, as yet unspecified, the compound is said

* This paper was presented at a symposium on the "Mechanism of Enzyme Action," sponsored by the McCollum-Pratt Institute, Johns Hopkins University, Baltimore, Maryland. It is to be published in the proceedings of that symposium.

** This work was sponsored, in part, by the U.S. Atomic Energy Commission.

to be a chelate compound. The word comes from one of the ancient languages (Greek) and means claw, and it is quite clear how the word was derived. Thus chelate compounds, especially the ones that I am going to speak about today, may be said to be a special class of the more general type of compounds which we call "complex" compounds. Some specific examples of chelate compounds are shown in Figure 2, in which the ordinary complexes are given in the top row and a wide variety of chelate complexes related to them, by one or another means of classification, are shown below. Thus, in the first column, we have hexaminocobaltic ion, in which the ligands are all separated -- an ordinary complex compound. If, however, two or more of those amino groups are bound together, as in ethylenediamine, we then speak of the compound as being a chelate compound. In this case, the ligands are all uncharged atoms -- uncharged nitrogen atoms in the amino compounds and uncharged oxygen atoms in the hydroxylated compounds. In the next case of a complex ion (hydroxypentammine cobaltic ion), we have an example of a mixture of ligands, some of them charged (in this case, only one of them is charged). Correspondingly, one can make chelate compounds in which the mixture of the ligands is changed in the same way; below we have a neutral nitrogen and a charged oxygen; a neutral oxygen and a charged nitrogen; one neutral oxygen and one charged; finally, both are charged (in the oxalate compound) and uncharged (in the glycol compound). There is a wide variety of such arrangements which can be made and a number of classifications of chelate compounds have been devised which depend upon one or another mode of description. One major type of classification of chelate compounds would be the number of ligands which are tied together in a single or multiple claw. This is perhaps the most useful single type of classification. Thus, a single, non-chelating ligand such as ammonia is said to be monodentate, while the ethylenediamine compound would be spoken of as a bidentate compound, in that there are two coordinat-

ing groups in a single chelate ring. If three coordinating atoms are part of the same chelating group, then it would be a tridentate chelate compound. A bidentate ligand would form a single chelate ring, while a tridentate reagent would form two rings. I can't try to go into the details of this type of mechanical classification. A very nice treatise on this was written by Harvey Diehl¹ at Iowa some fifteen years ago, in which this type of classification is described.

To pursue this interest and work in chelate compounds and the part they might play in biocatalysis, we had to decide what type of measurements -- physical or chemical -- might be the most useful for the purpose of giving information about the nature of chelate compounds, leading ultimately, of course, to some clues as to why they are important in biocatalysis. One very simple type of measurement which could be made and which is easily defined was the stability of the chelate compound. The way the stability of the chelate compound was measured depended upon the particular system. Figure 3 shows how such association constants are defined algebraically -- the metals plus the chelate group form a metal-chelate associate. I have here written the chelating group as a charged one; it doesn't necessarily have to be; n could be zero, positive or negative. Most of them are either neutral or negative, at least this is true of most of the ones I am going to talk about this afternoon. The various types of constants are defined quite clearly here in terms of equilibrium and dissociation constants, and most of the data presently being collected are expressed in terms of the successive stepwise stability constants, k_1 , k_2 , etc. and K , which represents the product of the stepwise stability constants.

Having such measurements at hand, the next stage in the study was an attempt to deduce what the factors are which influence the stability constants for a variety of chelate compounds. The classification of effects shown in Figure 4

(1) Diehl, Chem. Rev. 21, 39 (1937).

resulted after a considerable amount of work and it was clear that a number of factors play a part in determining the value of such an "association" constant. Some of these were also playing a part in the binding of ordinary complex compounds; that is, they are not necessarily limited to chelate compounds. The dotted line is the line which divides the two areas -- those factors which are related to the stability of complex compounds in general -- not limited necessarily to chelate compounds -- are to be found above that dotted line; those which are characteristic and limited to chelate compounds themselves are below the line. Such things as steric effects due to limitations imposed by the rings, entropy effects and resonance effects are not to be found in simple complex compounds, at least in the form in which we will talk about them this afternoon. It is my purpose to try and limit our examination to the variation of stability constants of chelate compounds with factors that are characteristic of the chelating group itself. However, in order to make possible some discussion of the effect of variation of metal ion on properties related to chelation and catalysis it will be useful to point out at least one rather simple empirical relationship between a fundamental property of the electron configuration of the metal atoms and the stability of the complex compounds they form. This relationship provides a first approximation toward a more fundamental theory.

It should be noted that in the types of complexes that we are describing, the coordinating atom always donates a pair of electrons to the metal ion with which it complexes. Insofar as these electrons may be conceived as returning to vacant orbitals in the metal ion, one might expect that the energy of such a bond would be determined by the depth (on the energy scale) of the vacant orbitals into which they fall. This depth, in turn, might be measured by the energy required to

remove electrons from those and closely related orbitals. Thus, we are led to expect some sort of monotonic relationship between the energy required to remove the last electron in the production of the ion and the stability of the complex compound formed by that ion. Such a relationship is shown in Figure 4A. The ionization potential required to remove the last electron in the formation of a specific ion is plotted as the abscissa with the logarithm of the formation constant of a chelate compound with that ion as ordinate.² The formation constant is defined by the equation (1) in which the coordination group is the anionic dibenzoylmethane (DBM).

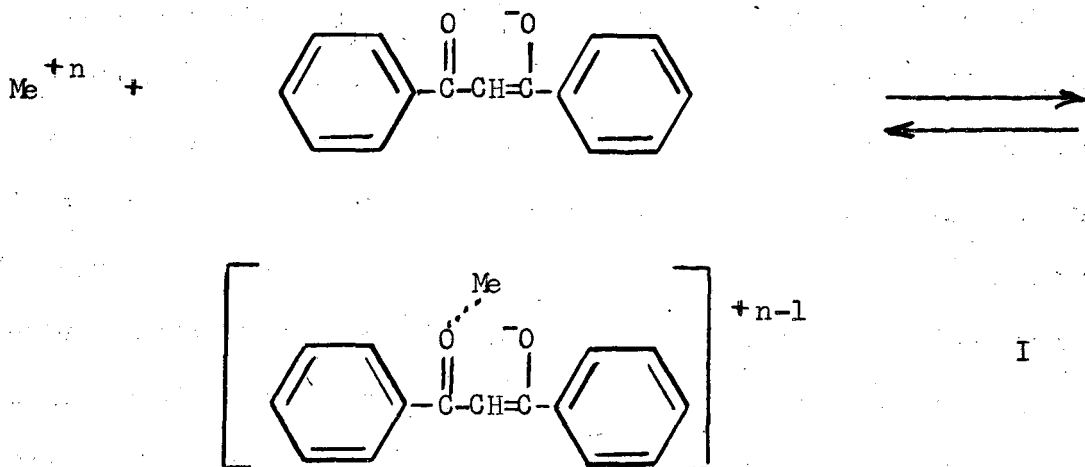

$$K_f = \frac{[\text{Me}(\text{DBM})^{+n-1}]}{[\text{Me}^{+n}][\text{DBM}^{-1}]} \quad (1)$$

Other derived or secondarily determined properties of the metals have also been used to demonstrate such relationships, and a comparable graph involving χ_m which is the electronegativity and B_h which is the hybrid bond orbital strength is shown alongside the ionization potential plot. Further description of these

(2) Van Uitert, Fernelius and Douglas, "Studies in Coordination Compounds. VII. Chelate Compound Dissolved State," J. Am. Chem. Soc., in press.

latter two is to be found in connection with experimental work in which the data were obtained.² It is to be expected that such an ionization potential-complexing constant plot would contain fewer deviations if it were made with a simple complexing constant such as amine formation or even complexing constants with ethylenediamine rather than the β -diketone for which it was first produced. One could then proceed to examine the larger deviations from the plot in terms of special chelation effects. Even in the present plot (Figure 4A) it is interesting to observe that the stability constant of cupric ion for this β -diketone seems to be too great for its simple ionization potential. We will come back to this characteristic of cupric ion again later.

We can return now to a consideration of those factors more closely dependent upon the existence of chelation itself -- those listed below the dotted line in Figure 4. These three factors can be grouped into two types -- the steric and entropy effects are the effects in which chelation changes the translational, rotational and vibrational energy distribution of the chelate group. The resonance effects, on the other hand, are effects which have to do with the change in the electronic energy of this chelating group, not to the exclusion of translational, vibrational effects, but in addition to those. Let us have a look at each of these, in the order shown, and pick out more or less clearly defined examples of each case.

The first of these, the steric effect, is quite easily defined, and a type of compound upon which Schwarzenbach³ made a series of measurements which is shown in Figure 5 will exemplify such steric effects. He measured the binding constant of a series of metals with a series of polymethylenediaminetetraacetic acid derivatives as a function of the size of this ring. He found that there was a definite

(3) Schwarzenbach and Ackerman, *Helv. Chim. Acta*, 31, 1029 (1948).

sequence of stability constants, depending on the size of the ring, which is shown in Figure 6. Here, the size of the ring is given by n , the number of methylene groups between the two nitrogen atoms. In the alkaline earth sequence, there is a maximum for calcium. You will also notice that as the number of carbon atoms lying between the two nitrogens increases, the binding of calcium decreases. However, the binding of hydrogen does not change very much; in fact, the binding of hydrogen actually increases a bit, if anything. The quantities labeled K_1 are the acidity constants for the corresponding hydrogen ion dissociation. Why do we put the binding of hydrogen ion down for comparison? The chelating agent is, in effect, donating a pair of electrons to the central metal ions and this is chemically a function of a base. The metal is performing the acid function in place of hydrogen ion, so one would expect that there should be some parallelism between the binding of the metal and the binding of hydrogen ion. Whatever factor is involved in the binding of the hydrogen ion in the acid-base reaction should be, in some part at least, involved in the binding of the metal ion. In order to compensate for that factor, which really has nothing to do with the chelate phenomenon itself, we should compare chelate groups of like acidity with each other. We cannot always, or even frequently, make chelating groups of like acidity for comparison, but we can extrapolate the chelation constants to the corresponding acidities. Later on we will see how this can be done quite readily.

It is quite clear that the ring size has a pronounced influence on the binding of calcium which it does not have on the binding of hydrogen. This is the result of an interaction between the steric requirement of the chelating groups, which is determined by, among other things, the number of atoms, their distances apart, and the angular requirement of the bonds.

There is another very nice example of steric effects on stability constants to be found in a comparison of the binding of ethylenediamine and ammonia by silver ion.⁴ Silver ion binds ammonia (two of them) to form a complex ion with a fairly good stability constant. Log K is of the order of 7. If, however, one compares that with the binding of the two amino groups in ethylenediamine, one finds that the Log K of this chelate ion is only around 4.7. Now here is a case in which the complex ion is a linear ion, $H_3N:Ag:NH_3$, while the ethylenediamine ligand cannot readily form a linear complex with a single silver ion. In effect, then, the K value for ethylenediamine is really the stability constant of a single bound nitrogen or that of a chelate with a highly-strained metal bond, while that for the simple amine involves the binding of two nitrogen atoms in the most favored positions. This is an extreme case, wherein the steric requirement of the metal and the steric possibilities of the chelating agent make their chelating combination very difficult or even impossible. There are many other examples of steric effects on stability constants.⁵

The next type of effect to be considered is the one which we have chosen to call the entropy effect. The reason for calling it the entropy effect is that in those cases in which we have been able to determine the heat and entropy of the reaction by measuring temperature coefficients of the equilibrium constant, K, we find that the influence we have called the "entropy" effect in log K is found almost exclusively in the ΔS part of the free energy change and not in the ΔH part. There are various ways to formulate the effect, and I will choose one only; others are des-

(4) Schwarzenbach, *Helv. Chim. Acta*, 35, 2344 (1952); 36, 23 (1953).

(5) Martell & Calvin, "The Chemistry of the Metal Chelate Compounds," Prentice-Hall, Inc., New York, New York (1952).

cribed in the literature. Figure 7 shows an example of such a case, in which the stability of the compound is enormously enhanced by simply binding two sets of ligands together; the mere unification of the ligands to make a single molecule from two of them increases the stability enormously. These data are not stability constants themselves. They are quantities more or less directly dependent upon stability constants. $E_{1/2}^{(1)}$ happens to be a polarographic half-wave reduction potential, and $t_{1/2}$ is a half-time for exchange of cupric ion with the chelate bound copper, and in both cases an enormous increase in stability is apparent when two C-H bonds are replaced by one C-C bond. With the two pairs of bidentate donor atoms, the copper is reduced at a potential almost equal to that at which one can get reduction of aqueous copper; with the cupric ion bound by one tetradentate ligand, we have $3/4$ volt more stability. The contrast in the rate of exchange of chelated copper with cupric ion is equally great. There are many such cases, but no matter how you interpret them you can be confident that they will reflect in some degree the increased stability constants when they can be measured.

Figure 8 shows some cases in which stability constants were measured for such systems as these. Here, we have the equilibrium constant of the binding of six ammonias to nickel, for which the temperature coefficient has been determined, and we can separate out the heat and entropy terms. We have also the binding constant of three ethylenediamines by nickel, and again the heat and entropy terms have been separated. By combining these two, one can get the reaction involving the replacement of six ammonias by three ethylenediamines, to give the nickel ethylenediamine and six ammonias. The ΔH term is a small one; the "force" that drives this reaction to the right is the large increase in entropy. There are many other such cases; however, not enough as yet have been determined with temperature coefficients so that

we can say with a high degree of certainty that the mere tying together of the ligands increases the stability, not by an increase in the binding heat but by means of a change in the way the entropy is distributed on the two sides of the reaction. Figure 9 shows three more such cases which can be interpreted in this way. Unfortunately, for this system, one doesn't have temperature coefficients; one has only the Log K values at one temperature. In $\text{Zn}(\text{NH}_3)_4^{+2}$ there are four separate nitrogens on zinc (a Log K of 9.5); when you tie them together in pairs the Log K goes up to 11; and when you tie them all together in a single ligand the Log K goes up to almost 15. Here, we have all four nitrogens as part of a single chelating molecule. This would be spoken of as a tetradentate molecule, and the equilibrium constant is very much in favor of the binding. I suspect that when these Log K's are determined as a function of temperature so that we can separate the heat and entropy terms, most of this extra stability will appear in an entropy term. The simplest interpretation is that on the left-hand side of the reaction one has zinc binding four or five water molecules plus the tris- β -aminoethylamine, while on the right-hand side one has the zinc complex, plus four or five free water molecules, and thus a net increase in total number of molecules, or the total number of translational degrees of freedom. One could describe it also in terms of the relative probabilities of forward and reverse reactions, and thus translate the thermodynamics into the language of kinetics. So much, then, for the so-called entropy effect.

The third and last factor listed^{as}/especially concerned in determining chelate stability is the resonance effect. In all of the previous cases of binding together of the ligands to make the chelate compounds, the two bound donor atoms have no electronic interaction with each other outside the chelated element. In Figure 10 we see examples of chelate compounds in which this is not so, in which there is, at

(6) Schwarzenbach, *Helv. Chim. Acta* 35, 2344 (1952).

least possible, a direct electronic interaction between the two donor atoms. In each acetylacetonate (and salicylaldehyde) chelate ring, there is a direct electronic interaction possible between two oxygen atoms (or between one oxygen and one nitrogen atoms), through the conjugate system. These are quite different sorts of chelating systems from the others such as ethylenediamine in which there is no possibility of electronic interaction between the ligands. It is the peculiar characteristics of such chelate compounds that arise from the possibility of forming closed cyclic resonance systems through the orbitals of the bound metal atom that next claim our attention.

How can we find the nature of the effect of such a possibility on the stability constant? We could compare each of the upper compounds (Figure 10) with the corresponding lower one. For the pair on the right, the comparison is made via polarographic half-wave potential which, for salicylaldehyde, is very nearly that of unchelated free copper ion, while the acetylacetonate is slightly more stable than the copper ion. In the pair on the left, we have the same difference; the comparison here is via half-time for exchange between aqueous copper ion and bound copper ion. In both cases, the acetylacetonate molecule (or the derivative of acetylacetonate) is the more stable one, when compared with the corresponding derivative of salicylaldehyde. Now, one can make a more detailed examination of the same structures in terms of binding constants, and Figure 11 shows the results of such measurements which were made quite a number of years ago. There are better ones available now, but these show the essence of the effect. This is a plot of the binding constant for copper against the acidity constant of the same chelating group. The upper solid line corresponds to a series of substituted salicylaldehydes, while the lower solid line corresponds to a series of β -diketones related to

acetylacetone. It is thus clear that there is a component in the binding of copper ion which is exactly parallel in the binding of a proton. There is also a component which is very different for the two cations. Thus, when we compare the binding of copper ion by a salicylaldehyde with the binding by an acetylacetone residue of the same acidity, we find that the acetylacetone binds copper some two powers of ten more strongly than does the salicylaldehyde. Here we have the essence of this so-called "resonance" effect. You see in the direct measurement of the stability constant how the acetylacetone binds the copper much more strongly than does the salicylaldehyde. There are two other dotted lines in Figure 11, but one can hardly speak of them as being defined by experimental results, since each line has a single point on it. The reason they are drawn that way is my faith that when such a series of compounds are made they will fall on these lines; perhaps one day one of you will have an opportunity to do this. The question now arises as to why do these compounds fall in the series they do. Comparing at constant acidity, you find that the 2-hydroxy-3-naphthaldehyde binds copper the poorest, the salicylaldehyde is next, the 2-hydroxy-1-naphthaldehyde next, and the β -diketones (acetylacetone) most strongly.

Figure 12 shows the elements of structure which are involved in these four compounds in inverse order. The essence of structure which runs in that order is the double bond character of the carbon-carbon bond adjacent to the anionic oxygen. In acetylacetone, there is nothing to interfere with the double bond. In 2-hydroxy-1-naphthaldehyde, the double bond is double two-thirds of the time -- the other one-third of the time it is a single bond, because it is involved in this naphthalene resonance. This is the simplest and most naive description, and it is the most readily visualized. In salicylaldehyde, the bond is part of a benzene ring and thus is double only one-half of the time, and in 2-hydroxy-3-naphthaldehyde the bond in

the naphthalene is present only one-third of the time. These numbers, then, would correspond to what we might call a bond order designation, and this is exactly the stability constant order found for the binding of copper. This suggests the fundamental structural origin of the effect of electronic interaction between two ligands.

It would appear, then, that the resonance forms which play an important part in the binding of copper could be represented as shown in Figure 13. The two resonance forms characteristic of acetylacetonate ion would be those two represented as the upper pair, in which a single electron pair on each of the two oxygens is involved in the bonding of copper ion. The only difference between the two forms is the shift of an electron pair between the two oxygen atoms through the conjugated carbon chain. Actually, that is only one way of representing it, and doesn't give any real reason for understanding why copper should be bound more strongly to a compound in which this is possible than to one in which it is not possible (or possible to a smaller extent). Therefore, I think it would be better to represent the binding as shown in the lower set of formulas in which a pair of electrons has actually gone over and formed, formally at least, a double bond with the copper so that one has what looks like a benzenoid type of system involving the copper atom. These, then, are the two benzenoid, or Kekule', type forms if one uses the valence bond mode of expression. When this was first done, some ten years ago, it required a good deal of fortitude to write this double bond. Nowadays, it isn't such a shock to do it because one can avoid the actual writing of a double bond to the copper by using the molecular orbital mode of representation in which the one d -orbital together with one s , and two of the p -orbitals of the copper are used to make the four single bonds, and the remaining p -orbital of the copper is the one that is used to form a π -bond system with the p -orbitals of the oxygen and carbon atoms

of the conjugate ring. Thus, one gets a straight-forward representation of the π molecular orbital system which requires resonance between Kekule forms in the valence bond representation (Figure 13A).

We have described at some length the various ways in which the metals will interact with the chelating groups and the particular factors which influence that interaction. The next phase of our discussion is to try to apply these principles to the catalytic functions which chelate compounds have. The chelate compounds most familiar to us in biology are the ones responsible for the red of hemoglobin (hemin) and the green of plants (chlorophyll), but there are many others which are not so well known and which are somewhat simpler in structure. Actually, rather than try to devise a detailed description of the mode of catalysis of such substances as hemoglobin (or hemin), or catalase and chlorophyll, I think it might be better to examine a few suggestions of chelate action -- catalytic action -- pretty much along the lines we have just described for stability constants. I suspect that one will be able to divide the catalytic functions of chelates into two general types, as were used to describe the stability constants, namely, those interactions which involve the changes in translational, rotational and vibrational energy systems of the chelating group, and those involving electronic changes.

The ones that involve changes in translational, rotational and vibrational degrees of freedom will be those which are primarily entropy effects, and we sometimes speak of them as steric effects in reaction rates. A particular biochemical example of that comes out when one examines the fact that in practically every phosphatase that has been described to any extent at all, where the enzyme has been isolated, or at least partially purified, and the nature of the metal requirements known, it has been found that either magnesium or manganese is usually required.

I would like to suggest that the nature of the magnesium or manganese function is a chelating function -- a chelating action -- which has to do with the bringing together of the coenzymes and the enzyme, through a double chelate ring. The structure of such a complex is shown in Figure 14. The enzymes involved here are phosphatases (or phosphate transfer systems of one sort or another) and they participate in the action of one or another of a group of coenzymes, everyone of which has a pyrophosphate structure in it. The reason that this can occur is the presence of the pyrophosphate linkage in the coenzyme and some similar corresponding chelating linkage in the enzyme itself. If the coenzymes were simple phosphates, or if they were single binding ligands on the enzyme, they would not have the binding constants required to bring the coenzyme and the enzyme together. This would show up, for example, not in the heat of activation of an enzymic reaction, but rather in its so-called "temperature independent" factors.

The next case we will have a look at is one from straight organic chemistry, in which possibly both the entropy and the electronic, or resonance, effects might play a part. This is the reaction of an alkylation of a β -keto ester, using the sodium salt on the one hand, and the copper salt of the β -keto ester on the other. It might be worthwhile to put down what that reaction is, as you normally see it. It is written this way:

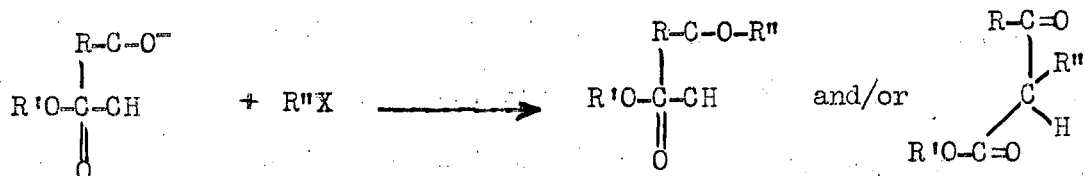

Sometimes one gets the O-alkylated product of the ketonic oxygen, and sometimes the C-alkylated product. Recently a comparison was made of the alkylation of the sodium salt and the copper salt, not of the acetoacetic ester itself, but of its diethyl

amide. A very interesting difference became apparent. Figure 15⁷ will show an interpretation of the effect. When one alkylates the sodium salt, one gets almost exclusively the normal alkylation reaction, or sometimes perhaps on the enolic oxygen. On the other hand, when one alkylates the copper salt, one gets a ketene acetal, derivative. In other words, one alkylates the amide carbonyl instead of the ketonic carbonyl. This is presumed to be due to the establishment of an equilibrium between two different chelate compounds, one in which the two ligands are both oxygen atoms and one in which the carboxamide group is turned around/^{and} the copper binds the nitrogen better than does the sodium. The copper, in other words, forms a relatively stable chelate compound with the oxygen and nitrogen, and the sodium does not. The sodium gives the ordinary alkylation; the copper exposes the amide carbonyl in an anionic form, so that it alkylates to a ketene acetal. This is almost a qualitative difference.

Let us go back again to cases closer to biochemistry in which the situation is more nearly an electronic one; for example, the catalysis of decarboxylation of keto-succinic acid derivatives. Figure 16 shows how these catalyses have been formulated.⁸ Here, we have copper catalysis of the decarboxylation of a number of keto acids through the formation of a chelate ring between the carbonyl and the α -carboxyl group. The demand for electrons by Cu^{+2} results in an electron shift from the β -carboxyl toward the carbonyl, liberating the carbon dioxide and forming an unstable intermediate. This then loses copper, forming the unstable enol of the simple α -keto acid. This is the way in which the catalysis of the decarboxylation of oxalacetic and oxalsuccinic acid has been formulated, because one can't get that catalysis, whether one has hydrogen on the reduced carbon atom or not.

(7) Utzinger, *Helv. Chim. Acta*, 35, 1359 (1952); *Angew. Chem.* 64, 622 (1952).

(8) Steinberger & Westheimer, *J. Am. Chem. Soc.* 73, 429 (1951).

The next such case is somewhat less explicit but perhaps more spectacular. It is an example encompassing a whole variety of reactions which take place essentially only in the chelate compound and which are very difficult to perform in the absence of a chelate compound. Figure 17 shows such a model substance. It consists of the Cu (or Ni) chelate of salicylaldehyde, which can form a Schiff base with an amino acid ester. This is the ester of an α -amino acid. When one forms such a Schiff base between salicylaldehyde and some α -amino acid ester, one can make a copper chelate of it, which is represented by the left half of the formula. However, as soon as one makes the copper chelate, a number of reactions take place very readily on the α -amino acid ester portion which do not take place on the free α -amino acid ester, or the free α -amino acid, very easily. First, is racemization; that is, the α -carbon is an asymmetric carbon atom, and immediately you put it into the copper complex it racemizes. Another one is oxidative deamination; that is, if one blows air through an alcoholic solution of this copper chelate, one can isolate the oxidatively deaminated keto acid ester. Or, if one maintains anaerobic conditions so that one does not get oxidative deamination but dissolves the chelate in an alcohol with an R group different from that of the original ester, ester exchange takes place as fast as you can dissolve it and recrystallize it. This is an unusual thing. One doesn't usually get ester exchange on any esters, except α -keto esters, very rapidly. Certainly amino acid esters do not undergo ester exchange by simply dissolving them in an alcohol and recrystallizing them. Thus, we have taking place on the chelate at least these three reactions which do not take place at all, or very reluctantly, on the non-chelated molecules - the salicylaldehyde Schiff's base without the copper, or the copper salt without the salicylaldehyde, or the amino acid ester itself. It is presumed that all of these reactions take place via a tautomerization which is possible in the

chelate compound, or at least is induced by chelation, due to the electronic interaction with the chelated metal. The α -carbon atom loses its asymmetry by a hydrogen transfer, a sort of keto-enol transfer across the aldimine double bond to form the molecule as represented by the right half of the formula. This, then, could be hydrolyzed giving the keto acid ester and a benzilamine which is very easily auto-oxidized by air, in the form of its copper complex. Thus, the net result would be either isomerization, or oxidative deamination. Why the ester exchange takes place so rapidly is not so readily apparent from the formulas as written, but it has been interpreted⁵ in terms of the withdrawal of electrons from the ester grouping through the conjugate ketimine toward the copper, giving it a more reactive oxygen function.

One can carry this analogy one step further to the well known structure of pyridoxal, which is very close to salicylaldehyde and which does this very thing in nature. Pyridoxal we know is involved in transamination reactions and it has been suggested that it functions as a chelate.⁹ As a matter of fact, recently the copper chelate compounds of pyridoxal and α -amino acids have been made and their structure is shown in Figure 18. Here the relationship between pyridoxal and salicylaldehyde is very clear, and the transamination reaction (oxidative deamination on the one hand and reduction on the other) all can take place via such transfers as I have just described for the salicylaldehyde complex. Baddiley¹⁰ at the Lister Institute who made these complexes showed that the reaction did take place quite readily without enzymes in ordinary aqueous systems. The transformation from pyridoxal and amino acid

(5) Page 400.

(9) Snell, J. Am. Chem. Soc. 67, 194 (1945).

(10) Baddiley, Nature, 170, 711 (1952).

to pyridoxamine and keto acid, and the order of activity of the elements in the non-enzymatic reaction is shown here, and you will notice that the copper outshines them all. This is undoubtedly due to the unique position of cupric ion with respect to the energy level of its unoccupied dsp-orbitals. One could go on collecting other such cases of catalytic activity of metal chelates over a wide range, and the cases become less definitive and more and more open to speculation.⁵ This, I think, is one of the areas in which we can stand a great deal of investigation. I have no doubt that such studies will contribute toward an understanding of the nature of the catalytic function in general and particularly in such extreme cases as catalase, hemoglobin and chlorophyll.

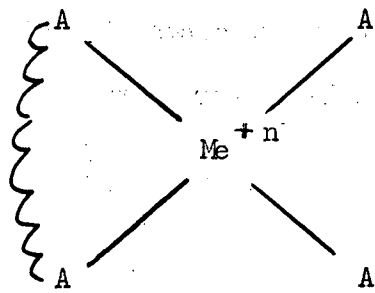

Complex Ions and Chelate Compounds

Figure 1

Figure 2

Various Types of Complex Ions and Chelate Compounds

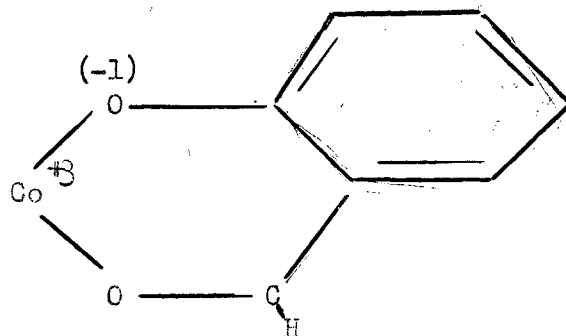
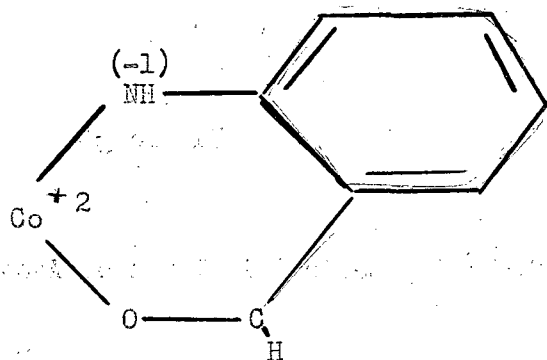
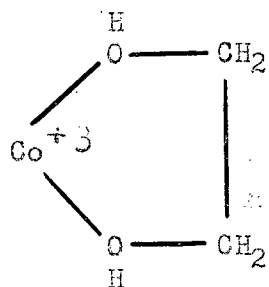
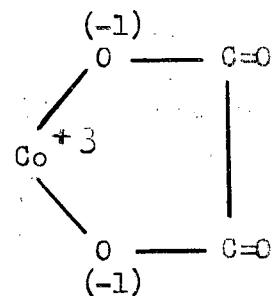
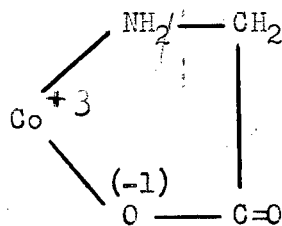
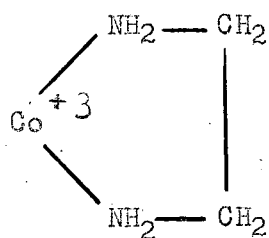
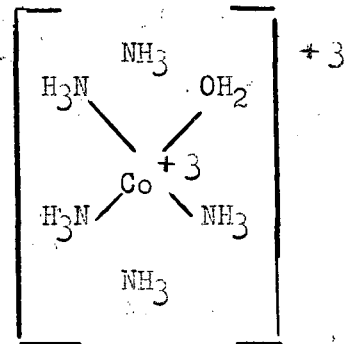
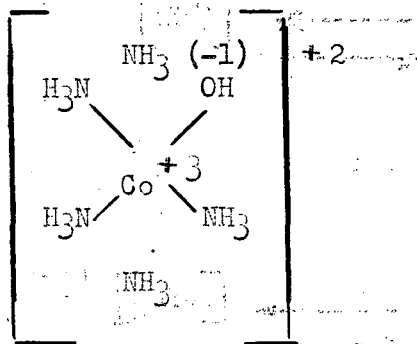
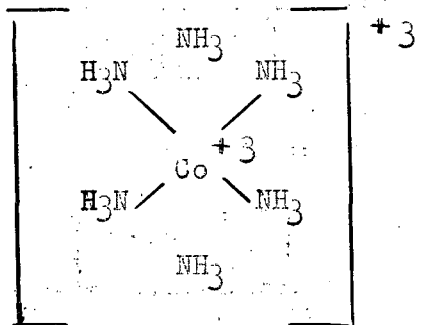

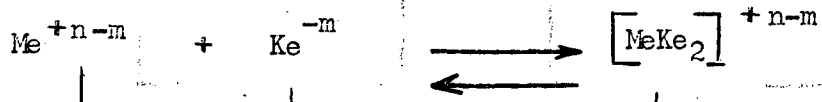
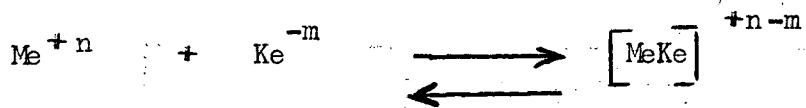

For the case $n = 2, m = 1$

$$k_1 = \frac{[\text{MeKe}]^{+n-m}}{[\text{Me}^{+n}][\text{Ke}^{-m}]}$$

$$k_2 = \frac{[\text{MeKe}_2]^{+n-2m}}{[\text{MeKe}^{+n-m}][\text{Ke}^{-m}]}$$

k_3

Figure 3

Stability Defined in Terms of Association Constants

FACTORS INFLUENCING THE STABILITY OF
COMPLEX COMPOUNDS

<u>Metal</u>	<u>Complexing Group</u>
charge	polarizability
radius	size (steric repulsion)
available orbitals	basicity

steric effects
entropy effects
resonance effects

Figure 4

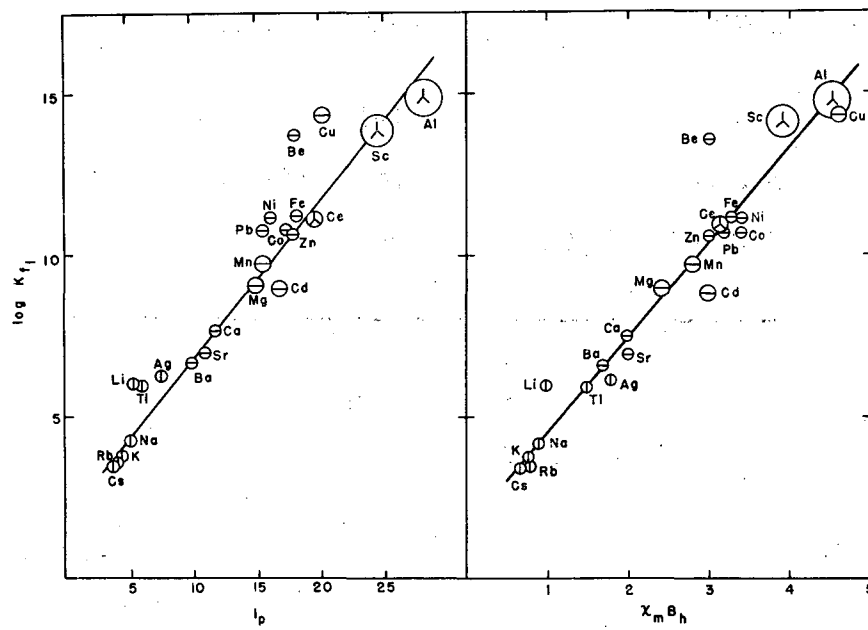

MU-4949

$$K_{f1} = \frac{[Me(DBM)^{n-1}]}{[Me^{n+}][DBM^{-1}]}$$

DBM = Dibenzoylmethane

Figure 4A

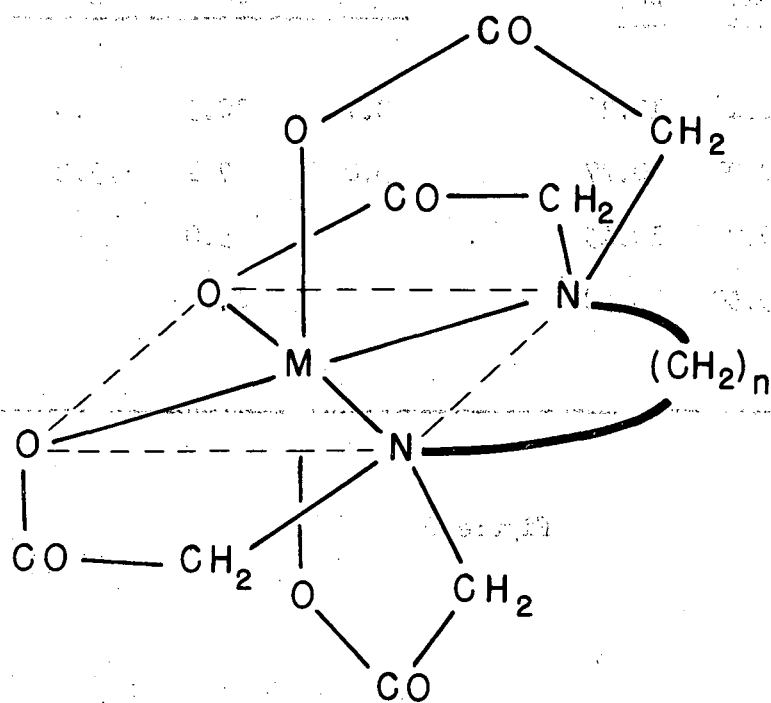
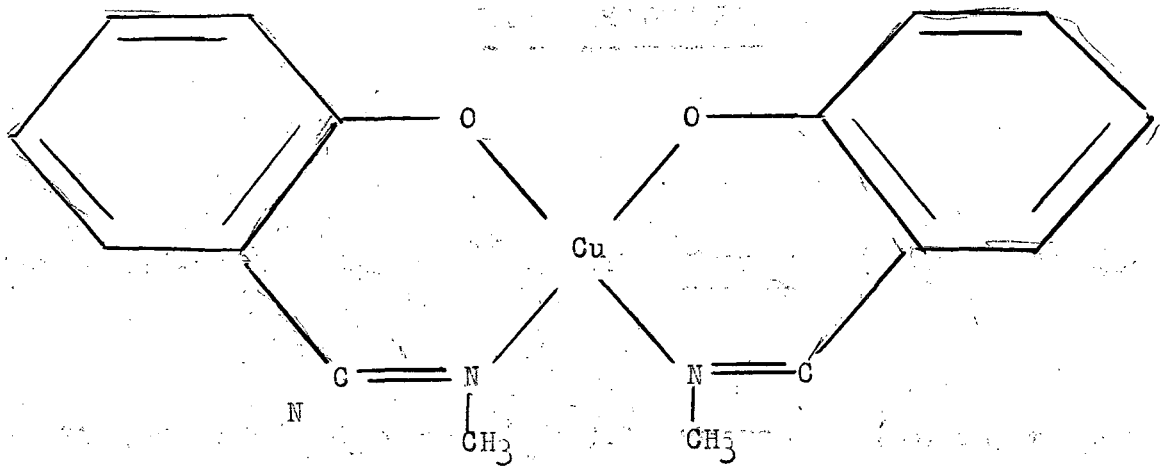

Figure 5

Stability Constants of Alkaline Earth Complexes With
Homologs of Ethylenediaminetetraacetic Acid

<u>n</u>	<u>pK₁</u>	<u>pK₂</u>	<u>pK₃</u>	<u>pK₄</u>	Log K			
					Mg ⁺²	Ca ⁺²	Sr ⁺²	Ba
2	2.0	2.7	6.16	10.26	8.7	10.5	8.6	7.
3	2.0	2.7	7.91	10.27	6.0	7.1	5.2	4.
4	1.9	2.7	9.07	10.45		5.0		
5	2.2	2.7	9.50	10.58		4.6		

Figure 6



$$E_{1/2}^{(1)} = +0.02 \quad t_{1/2} = 15 \text{ sec.}$$

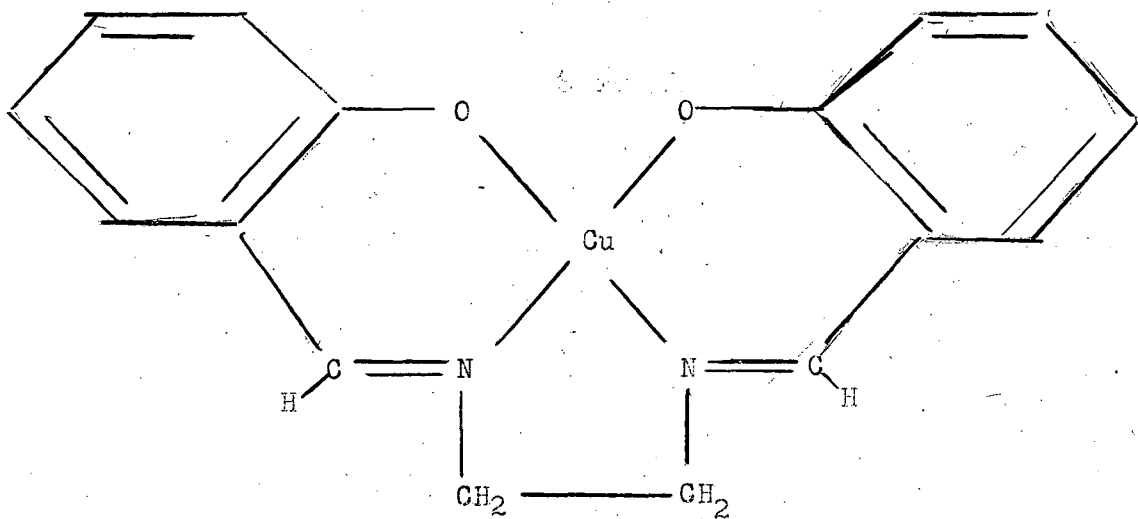

$$E_{1/2}^{(1)} = -0.75 \quad t_{1/2} = 2.1 \text{ hrs.}$$

Figure 7

THE ENTROPY EFFECT

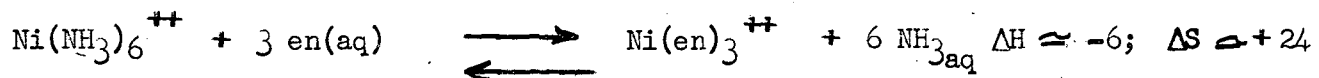
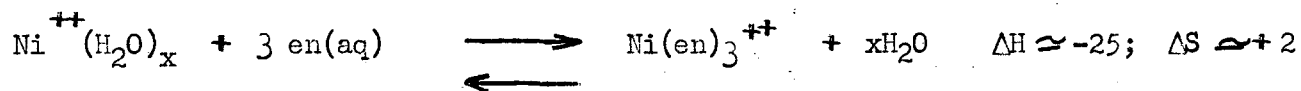
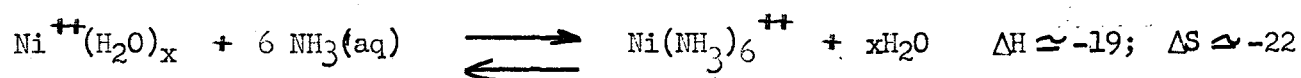
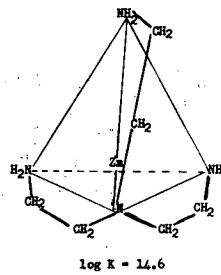
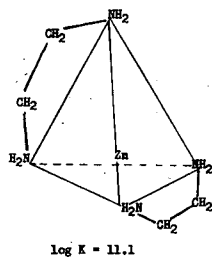
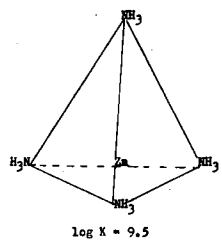

Figure 8



Effects of Chelation on Stability Constants

Figure 9

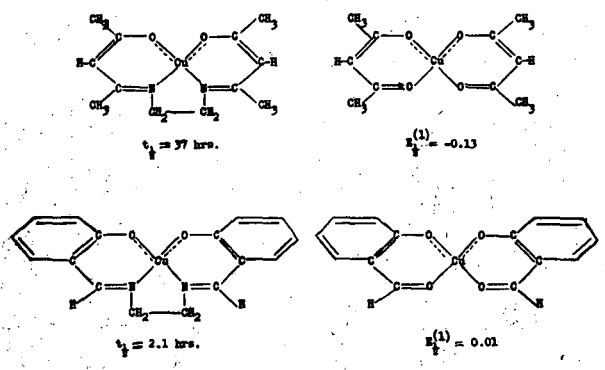

Figure 10

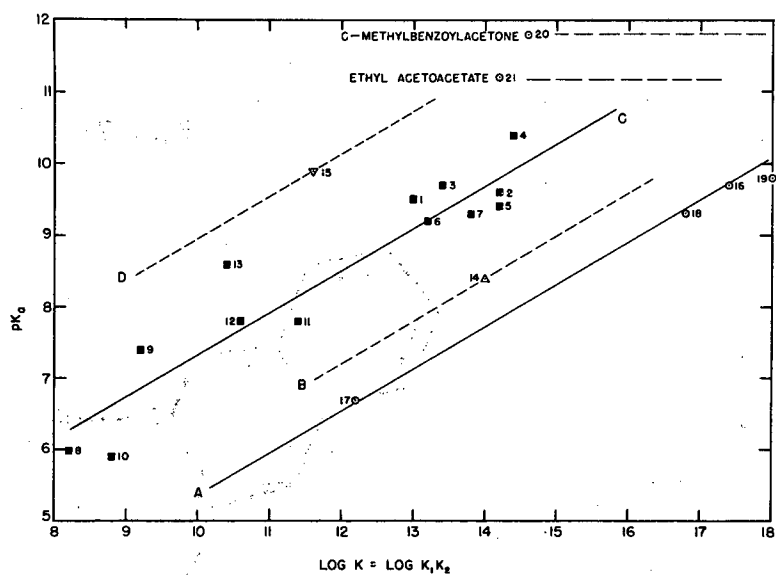
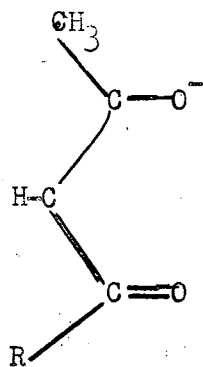
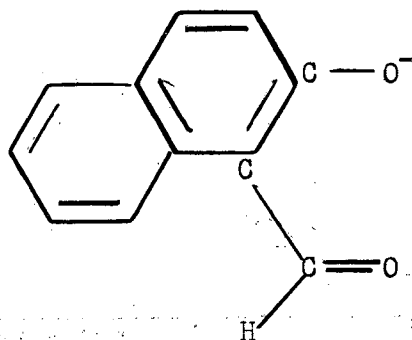

Figure 11. 1 salicylaldehyde, 2 3-n-propyl--salicylaldehyde, 3 5--methyl-salicylaldehyde, 4 4,6-dimethyl-salicylaldehyde, 5 3-ethoxy--salicylaldehyde, 6 3-methoxy-salicylaldehyde, 7 4-methoxy-salicylaldehyde, 8 3-nitro-salicylaldehyde, 9 4-nitro-salicylaldehyde, 10 5-nitro-salicylaldehyde, 11 3-fluoro-salicylaldehyde, 12 3-chloro-salicylaldehyde, 13 5-chloro-salicylaldehyde, 14 2-hydroxy-1-naphthaldehyde, 15 2-hydroxy-3-naphthaldehyde, 16 acetylacetone, 17 trifluoroacetylacetone, 18 furoylacetone, 19 benzoylacetone, 20 C-methylbenzoylacetone, 21 ethyl acetoacetate



A (2)



B(1.67)

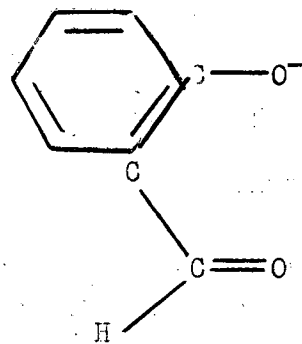

C (1.5)

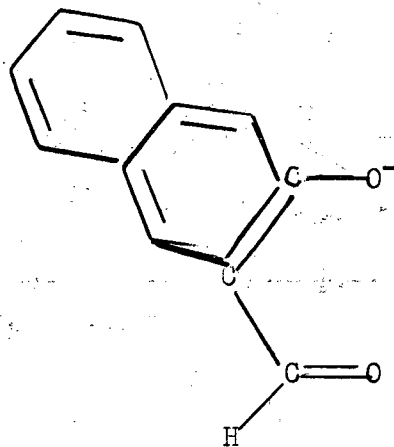

D (1.33)

THE RESONANCE EFFECT

Figure 12

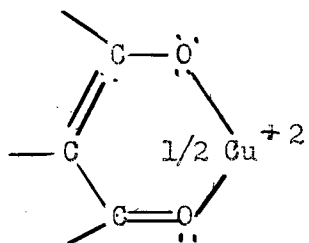

and

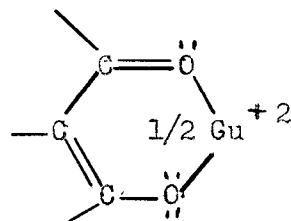

or

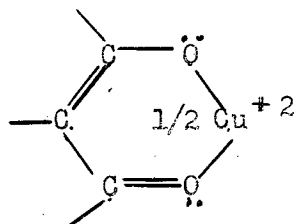

and

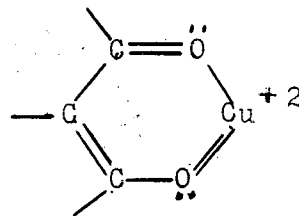
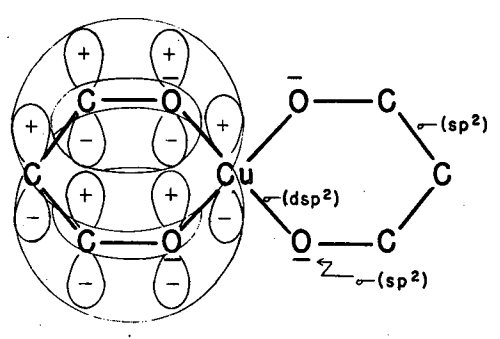
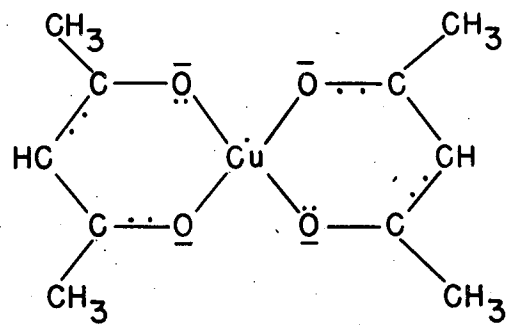
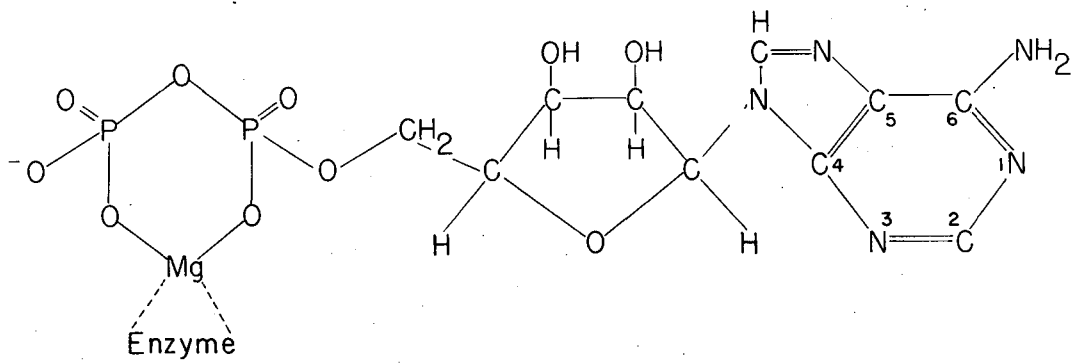

Figure 13



MU-4948

Figure 13A



Binding to Enzyme through
 chelation by metal ion,
 usually Mg.

ADP (ATP, DPN, TPN, UDP, CoA)

MU-4950

Figure 14

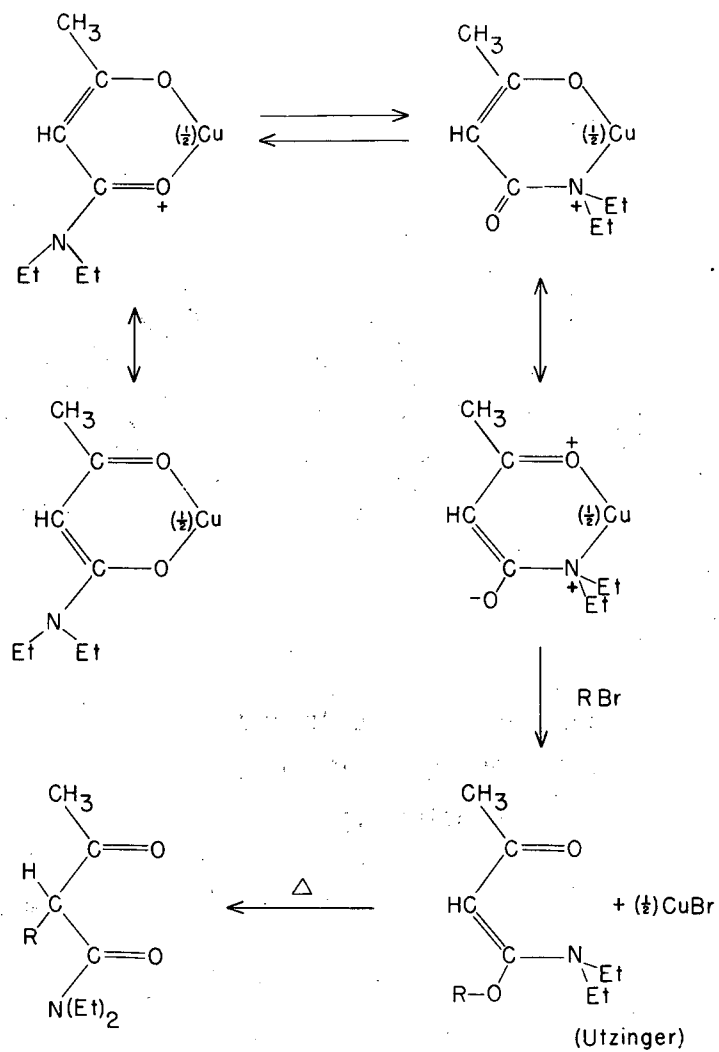

MU-4954

Figure 15

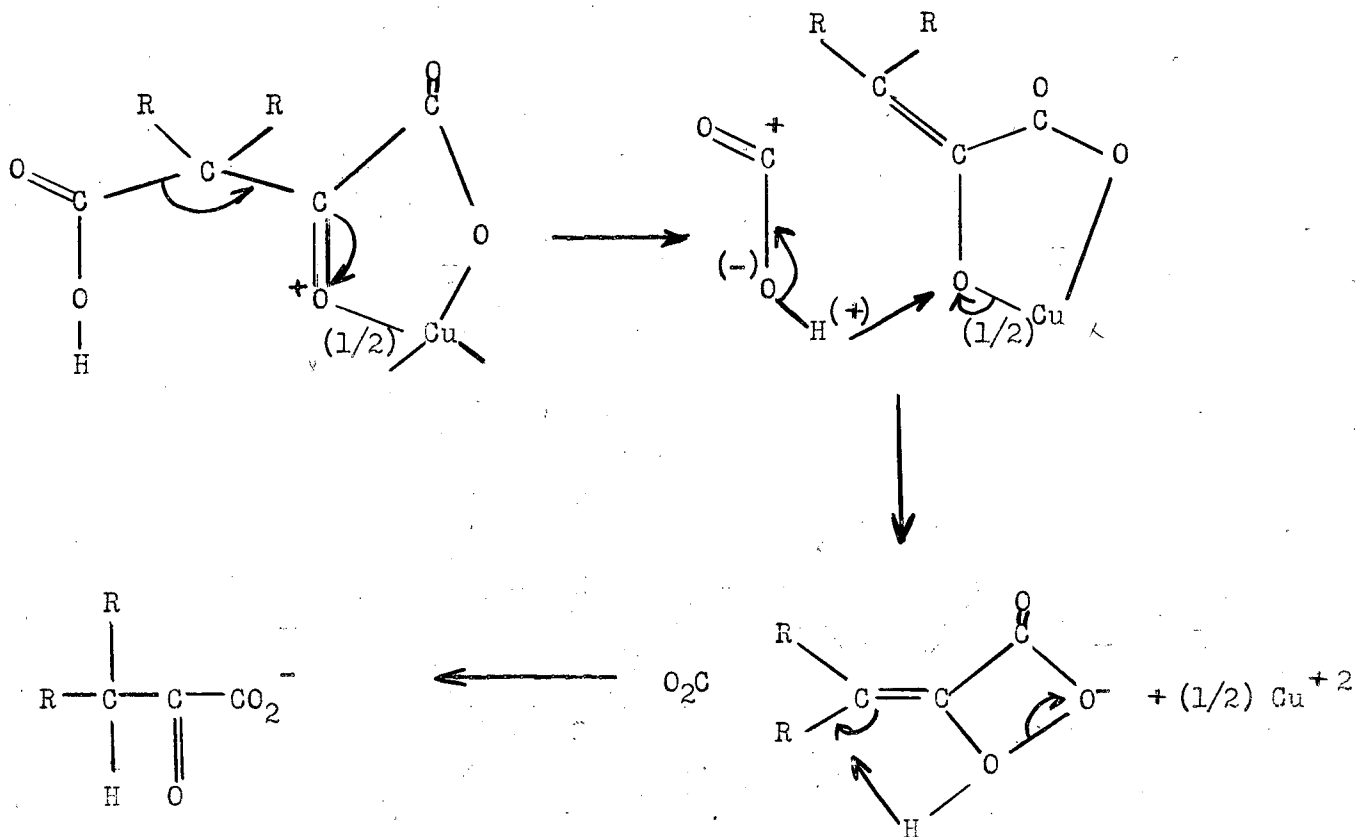

METAL CATALYZED DECARBOXYLATION OF KETO-SUCCINIC ACID DERIVATIVES

(OXALOACETIC)

(OXALOSUCCINIC)

Figure 16

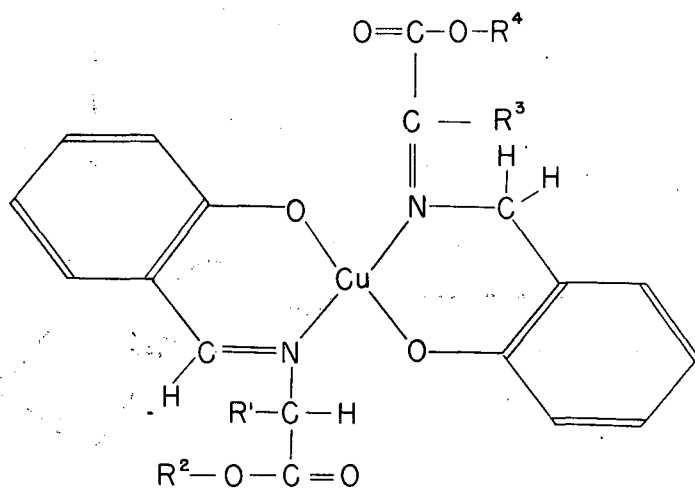

- A. Racemization
- B. Oxidative deamination
- C. Ester exchange

MU-4951

Figure 17