

UC Davis

Research Reports

Title

EVALUATE: Electric Vehicle Assessment and Leveraging of Unified models toward Abatement of Emissions, Phase I

Permalink

<https://escholarship.org/uc/item/9kh490xz>

Authors

Simmons, Richard

Weed, Caleb

Rodgers, Michael

Publication Date

2024-12-01

DOI

10.7922/G21Z42RG

Data Availability

The data associated with this publication are available at:

<https://doi.org/10.5281/zenodo.14347411>

EVALUATE: Electric Vehicle Assessment and Leveraging of Unified models toward Abatement of Emissions, Phase I

December
2024

A Research Report from the National Center
for Sustainable Transportation

Richard Simmons, Georgia Institute of Technology

Caleb Weed, Georgia Institute of Technology

Michael Rodgers, Georgia Institute of Technology



TECHNICAL REPORT DOCUMENTATION PAGE

1. Report No. NCST-GT-RR-24-40	2. Government Accession No. N/A	3. Recipient's Catalog No. N/A	
4. Title and Subtitle EVALUATE: Electric Vehicle Assessment and Leveraging of Unified models toward Abatement of Emissions, Phase I		5. Report Date December 2024	
		6. Performing Organization Code N/A	
7. Author(s) Richard Simmons, PhD, https://orcid.org/0000-0002-1783-3629 Caleb Weed, https://orcid.org/0000-0002-7351-2416 Michael Rodgers, PhD, https://orcid.org/0000-0001-6608-9333		8. Performing Organization Report No. N/A	
		9. Performing Organization Name and Address Georgia Institute of Technology School of Civil and Environmental Engineering 790 Atlantic Dr, Atlanta, GA 30332	
11. Contract or Grant No. USDOT Grant 69A3551747114			
12. Sponsoring Agency Name and Address U.S. Department of Transportation Office of the Assistant Secretary for Research and Technology 1200 New Jersey Avenue, SE, Washington, DC 20590		13. Type of Report and Period Covered Final Research Report (March 2021 – July 2022)	
		14. Sponsoring Agency Code USDOT OST-R	
15. Supplementary Notes DOI: https://doi.org/10.7922/G21Z42RG Dataset DOI: https://doi.org/10.5281/zenodo.14347411			
16. Abstract This research explores electric vehicle (EV) and grid interactions with a focus on CO ₂ emissions for future scenarios where EVs comprise growing market shares (e.g., 10% of the overall fleet mix). A major contribution of this effort has been to develop a methodology that integrates sub-system models and datasets that have previously stood alone, namely models and data that characterize: vehicle energy consumption, travel demands, vehicle charging, and temporal emission profiles associated with electric power generation dispatch. This convergence research helps quantify the relative emissions of light duty vehicle use and charging during various times of day to enable comparison of EV modes against one another and against conventional vehicle baselines. An initial use case involving light duty commuter and recharging scenarios has been explored as a means of validating and tuning the methodology. Under certain simulated scenarios, observed marginal emissions can be as much as 20% lower in the overnight hours compared to marginal CO ₂ emissions experienced during an identical charging event during the daytime. This study also confirms that marginal CO ₂ assumptions generally yield higher CO ₂ impacts than identical simulations that assume weighted average emissions. This variance is broad, ranging from 22% less to 97% greater, depending on a host of case-sensitive factors. These findings suggest that it will be essential to coordinate charging schedules and consider upstream grid implications in order to reduce the environmental impacts of EVs. By quantifying technical parameters related to both the magnitude and the range of possible emissions impacts, the study's findings can be useful for education and awareness by all EV users, and will help decision-makers consider the importance of emission rate assumptions and the temporal granularity of the tools and data. More specifically, stakeholders should be incentivized to charge when marginal emissions are lowest whenever possible. This idea also has important implications about the location, type, cost and ownership models for tomorrow's charging infrastructure. Translating and operationalizing this type of guidance will require some combination of education, access to rigorous and clear decision-support tools, signals between stakeholders (e.g., utilities and consumers), and behavioral change.			
17. Key Words Electric vehicles, low carbon transportation, emissions, CO ₂ , EV charging, marginal emissions, electric grid		18. Distribution Statement No restrictions.	
19. Security Classif. (of this report) Unclassified	20. Security Classif. (of this page) Unclassified	21. No. of Pages 58	22. Price N/A

About the National Center for Sustainable Transportation

The National Center for Sustainable Transportation is a consortium of leading universities committed to advancing an environmentally sustainable transportation system through cutting-edge research, direct policy engagement, and education of our future leaders. Consortium members include: the University of California, Davis; California State University, Long Beach; Georgia Institute of Technology; Texas Southern University; the University of California, Riverside; the University of Southern California; and the University of Vermont. More information can be found at: ncst.ucdavis.edu.

Disclaimer

The contents of this report reflect the views of the authors, who are responsible for the facts and the accuracy of the information presented herein. This document is disseminated in the interest of information exchange. The report is funded, partially or entirely, by a grant from the U.S. Department of Transportation's University Transportation Centers Program. However, the U.S. Government assumes no liability for the contents or use thereof.

The U.S. Department of Transportation requires that all University Transportation Center reports be published publicly. To fulfill this requirement, the National Center for Sustainable Transportation publishes reports on the University of California open access publication repository, eScholarship. The authors may copyright any books, publications, or other copyrightable materials developed in the course of, or under, or as a result of the funding grant; however, the U.S. Department of Transportation reserves a royalty-free, nonexclusive and irrevocable license to reproduce, publish, or otherwise use and to authorize others to use the work for government purposes.

Acknowledgments

This study was funded, partially or entirely, by a grant from the National Center for Sustainable Transportation (NCST), supported by the U.S. Department of Transportation (USDOT) through the University Transportation Centers program. The authors would like to thank the NCST and the USDOT for their support of university-based research in transportation, and especially for the funding provided in support of this project. The authors would also like to thank the anonymous reviewers that provided useful feedback to improve the quality of the final work. The authors would like to thank Georgia Tech graduate research assistants, Jason Hirschey and Karthik Sastry, for sharing data, analysis and consultation in the preparation of representative electric grid and EV charging profiles, respectively, that have been used in this study.

EVALUATE: Electric Vehicle Assessment and Leveraging of Unified models toward Abatement of Emissions, Phase I

A National Center for Sustainable Transportation Research Report

December 2024

Richard Simmons, Strategic Energy Institute, Georgia Institute of Technology

Caleb Weed, Department of Civil and Environmental Engineering, Georgia Institute of Technology

Michael Rodgers, Department of Civil and Environmental Engineering, Georgia Institute of Technology

[page intentionally left blank]

TABLE OF CONTENTS

EXECUTIVE SUMMARY	iv
1 Introduction and Research Background	1
1.1 Motivation and Scope	4
2 Methodology.....	6
2.1 Vehicle technology categories	7
2.2 Driving cycles	9
2.3 Mapping to representative commute categories.....	9
2.4 Models & Sources of Data	11
2.5 Overview of EV charging profile development and simplified use cases	11
2.6 Overview of grid emissions vs. tailpipe emissions.....	16
2.7 Overview of system integration and emissions aggregator	17
3 Results and Discussion	20
4 Policy Implications	28
5 Future Work & Limitations	30
5.1 Future Work	30
5.2 Limitations.....	31
6 Conclusion.....	33
7 References	35
8 Data Summary.....	38
9 Appendices.....	39
9.1 Appendix A – EPA Five-Cycle Computations.....	39
9.2 Appendix B – Level 1 Residential Charging Profiles.....	39
9.3 Appendix C – MATLAB Initialization Code	41
9.4 Appendix D – Output Data.....	42

List of Tables

Table 2-1. Specification table for the different vehicle architectures compared in the study [13]	8
Table 2-2. Effective fuel economy values	9
Table 2-3. Representative commutes developed for the comparative scenario analysis	10
Table 3-1. Variables included in the system-of-systems modeling approach	20
Table 3-2. Percent improvement in CO ₂ /km over ICEV baseline for the Long Commute trip in August	24
Table 9-1. Percent Improvement in kgCO ₂ /km over ICEV baseline (December outputs continued on the following page)	42
Table 9-2. kgCO ₂ /km (Level 2 charger) (December outputs continued on the following page) ..	44
Table 9-3. kgCO ₂ /km (Level 1 charger, residential charging)	46
Table 9-4. gSO ₂ /km for Suburban Errands Trip	47
Table 9-5. gNO _x /km for Suburban Errands Trip	47

List of Figures

Figure 1-1. EV deployment projections, based on new-vehicle market share [7] (Sources: BNEF, EEI, EPRI, DOE, etc.)	2
Figure 1-2. National variation of CO ₂ emissions from a typical light duty Electric Vehicle [11].....	3
Figure 1-3. Variation across the 23 most populated US cities for CO ₂ emissions (in gCO _{2eq} /km) from various light-duty vehicles. With 2020/2025 projections for Atlanta (ATL) [13].....	3
Figure 2-1. Integrated modeling methodology for combining vehicle, grid, and emissions considerations for simulation.	6
Figure 2-2. Fundamental powertrain model specific to each vehicle architecture (ICEV output shown for reference) [8].....	10
Figure 2-3. Basic EPA dyno schedules (UDDS, US06, and SC03 shown for reference).	11
Figure 2-4. Example workplace charging data of EV charging events on Georgia Tech campus from February 2020	13
Figure 2-5. Example workplace charging session duration on Georgia Tech campus from February 2020	13
Figure 2-6. Example of 2020 survey data characterizing EV charging behavior provided by Escalent [23].....	14
Figure 2-7. Examples of residential EV charging profiles used in the study	15
Figure 2-8. Examples of workplace EV charging profiles used in the study	15
Figure 2-9. Energy and emissions integrator (Simulink).....	19
Figure 3-1. CO ₂ emissions per kilometer (August).....	21
Figure 3-2. CO ₂ emissions per kilometer (October).....	22
Figure 3-3. CO ₂ emissions per kilometer (December)	23
Figure 3-4. SO ₂ and NO _x emissions per kilometer (August).....	26
Figure 3-5. SO ₂ and NO _x emissions per kilometer (October).....	27
Figure 9-1. Level 1 Residential Overnight Charging Profile	39
Figure 9-2. Level 1 Residential Daytime Charging Profile	40

EVALUATE: Electric Vehicle Assessment and Leveraging of Unified models toward Abatement of Emissions, Phase I

EXECUTIVE SUMMARY

Vehicle electrification is currently considered one of the most attractive means of decarbonizing major segments of the transportation sector and can also directly contribute to improvements in urban air quality and public health. In spite of substantial progress and proactive policy support, the environmental impacts of electric vehicles (EVs) under the wide range of future deployment scenarios are poorly understood. In certain intermediate-term scenarios where EVs reach a much larger share of the fleet and demand a double-digit share of available electric power (e.g., 2030), marginal CO₂ intensity during EV charging times will typically be higher than annual average CO₂ rates from the bulk power grid, upon which many current studies base their projections. On a 24-hour basis, this may be true for off-peak periods (e.g., overnight) as well as certain peak periods (e.g., early afternoon in summer, or early morning in winter). In certain conditions, even now, the average emissions assumption breaks down because of the high variability of generation requirements at the hourly or sub-hourly level in peak periods of the day or year.

This research explores vehicle-grid interactions with a focus on environmental impacts for future scenarios in which electric vehicles are on a trajectory toward substantial market share (e.g., 10% of the overall fleet mix). This project has leveraged and expanded a series of unique datasets and high-fidelity sub-system models that have previously stood alone as independent research contributions by the EVALUATE research team, its collaborators, and other researchers in the field. Those models govern vehicle energy consumption, travel demands, vehicle charging, and temporal emission profiles associated with electric power generation dispatch. Along with the expansion of those datasets and sub-system models, one of the most exciting contributions of this effort has been to develop an integrated methodology that enables high-fidelity evaluation of emissions, in a systems-of-systems framework. An initial use case has been explored as a means of validating and tuning the methodology, which has generated some valuable insights in its own right. The scope of this work is initially based on a regional case study (Southeastern US) for a target vehicle classification (light duty commuter vehicles).

This convergence research has revealed important findings relative to the comparative emissions impact of light-duty vehicle charging during various times of day. Such findings may be valuable to an individual vehicle owner. For instance, under certain simulated scenarios, we observe marginal emissions can be as much as 20% lower in the overnight hours compared to marginal CO₂ emissions experienced during an identical charging event during the daytime. This finding suggests that it will be essential to adjust and/or coordinate charging schedules to reduce the environmental impacts of EVs. More specifically, to the extent emissions impacts are prioritized among other objectives, individuals and policymakers should be encouraged or incentivized to charge when marginal emissions are lowest whenever possible. This idea also has important implications for the location, type, and ownership models for tomorrow's

charging infrastructure. Translating and operationalizing this type of guidance will require some combination of education, access to rigorous and clear resources, signals between stakeholders (e.g., utilities and consumers), risk management analyses, and behavioral change.

The study has also shed light on the critical nature of assumptions made for the dispatch of electricity generation to meet incremental new demand to charge vehicles. Several related observations are important to note and may be valuable for vehicle owners, researchers, and policymakers. First, our study is aimed at comparative analyses which provide insights into how a marginal assumption for CO₂ emissions compares to other marginal assumptions, as well as to prevailing approaches (i.e., weighted average annual assumptions). To our knowledge, this has not been done at this level of granularity. Second, in nearly all cases, marginal CO₂ assumptions yield higher CO₂ impacts than identical simulations that assume weighted average emissions. This variance is broad, ranging from 22% less to 97% greater, depending on a host of case-sensitive factors. The team believes its ability to initially quantify and bound this variance represents an important contribution, as it helps decision-makers quantify how important various assumptions are.

The research and its findings are provocative for additional reasons. Weighted average emissions in the U.S. are on a gradual decline, driven primarily by the retirement of coal and the addition of renewables over the past decade. This trend has favorable environmental impacts, because the retirement of high-intensity generation resources means they are less likely used to meet marginal demands, and similarly, the addition of low to no carbon-emitting resources has a commensurate impact on the weighted CO₂ intensity of the overall grid. However, it is highly unusual for renewables to be used as the principal means of meeting marginal demand because they are generally considered non-dispatchable. This means grid operators will use fossil-generating resources (with a few minor exceptions) as a means of meeting incremental load. Better foresight and energy storage are two areas that may eventually change this. On foresight, better awareness between stakeholders will help utilities predict and plan for EV charging events, which could presumably result in more holistic management of environmental impacts. Energy storage, at the moment, accounts for a very small fraction of total electrical demand, and it is therefore considered out of scope for the present study. Finally, despite encouraging trends in emissions for the bulk grid, the steady decline may plateau in the future for several reasons including: (a) if transportation demands a large share of electricity, (b) if costs to deliver electricity from zero to low carbon resources is substantially higher than conventional resources, or (c) if additional electrification occurs at scale within other sectors (e.g., conversion of process heating or large scale industrial processes from natural gas to electricity).

Still, by quantifying technical parameters related to both the *magnitude* and the *range* of possible emissions impacts as compared to multiple baselines (i.e., for vehicles, and for the grid mix), the study's findings can be useful for education and awareness by all EV users. They also have clear implications on policy and public investment as mentioned, including the urgent need for managed and coordinated charging, and greater attention to resource planning, in terms of generation resources, dispatch decision-making, infrastructure funding, and the long-

run environmental benefits and impacts for EVs across a range of use cases and time horizons. The report concludes with several suggestions for future work, including the need to leverage this methodology to consider grid characteristics relative to energy, emissions, decision-making, and planning out to 2030, and the capability of the tool to be scaled and more broadly adapted for conducting similar analyses in other regions.

1 Introduction and Research Background

Vehicle electrification is currently considered one of the most attractive means of decarbonizing major segments of the transportation sector and can also directly contribute to improvements in urban air quality and public health [1-4]. A key advantage of Electric Vehicles (EVs) compared to internal combustion engine vehicles (ICEVs) is that their carbon and emissions footprint is not fixed based on the vehicle technology from a given past model year, but instead can progressively improve in lockstep with a grid that is evolving toward a cleaner and lower carbon generating mix.

Driven in part by policy, declining prices, and product availability, EV deployments are accelerating, having surpassed 1,600,000 total vehicles in the U.S. fleet by August 2020 [5]. Though EVs still account for less than 1% of the domestic vehicle fleet, this growth is notable compared to a near-zero baseline in 2010. Significant challenges have been overcome during this “first decade” of commercial adoption, including range limitations, charging infrastructure, total cost of ownership, and public acceptance. As of December 2020, U.S. consumers can choose from more than 50 light-duty EV models that span multiple vehicle classes, markets, and a wide MSRP price range from \$27,500 to more than \$100,000 [6].

Projections for continued EV growth through the present “second decade” (i.e., 2020-2030) of mass deployment are varied, but many suggest a sustained exponential growth as evidenced by Figure 1-1 [7], which shows future market share as a fraction of new vehicle sales.

EVs are increasingly seen as a win-win solution by many policymakers, in that they can provide benefits to consumers, automakers, and utilities, while also reducing environmental impacts associated with tailpipe emissions [1-2]. Furthermore, while much public attention is focused on Light Duty vehicle markets, additional opportunities exist in Medium Duty (e.g., courier, public transit, school buses) and certain Heavy Duty (e.g., intra-state or regional) applications [8].

Despite substantial progress, widespread optimism, and proactive policy support, new and non-trivial barriers remain. These barriers may simultaneously threaten both broader adoption and certain beneficial outcomes of EV growth. Among the most critical and poorly understood, is the need to ensure environmental benefits live up to their promise, in particular under deep deployment scenarios where EVs comprise more than 10% of the future fleet by 2030, and demand commensurate new supplies of electric power in both time and space.

It is desirable to assess the criticality of environmental impacts, so as to quantify the levels of decarbonization enabled by EV penetration. However, empirical methods are presently insufficient for near term projections, due to uncertainties related to charging levels, charging times and the spatial temporal impact of different electricity generation mixes. Further compounding this challenge are insufficient data on EV growth and uncertain adoption rates. What happens, for instance, when EV load growth will require 20% more power demand than is currently forecasted in existing integrated resource plans, which already must also provision for an approximate 15% peak reserve margin? What happens when this average

increase in power demand is considered on an hourly or seasonal basis, spiking to much greater shares of reserve (i.e., 50% or greater). Assuming that utilities embrace an opportunity to sell more kWh to meet new market demands, what assurances are in place to protect the environmental footprint of new load growth?

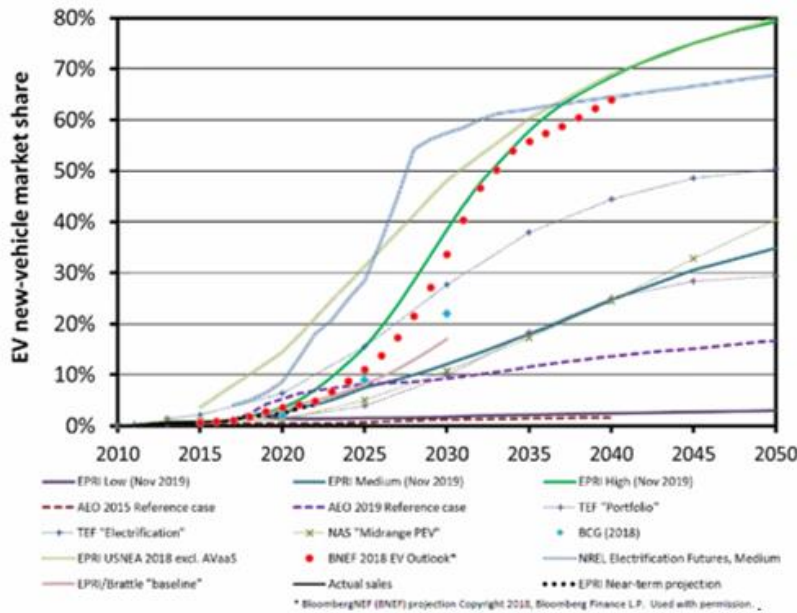

Figure 1-1. EV deployment projections, based on new-vehicle market share [7] (Sources: BNEF, EEI, EPRI, DOE, etc.)

Note: In our Drawdown GA model, a 20% market share for new EV sales in 2030 corresponds to an overall fleet share of about 4%, whereas if EVs comprise 40% of new sales, 9% of the fleet are EVs [9-10].

Modern studies that compare the environmental impacts of EVs with ICEVs often make a simplifying assumption that grid-average carbon and pollutant intensities can be used to estimate CO₂ and criteria pollutant impacts [e.g., 3,9-13]. Simplifying assumptions notwithstanding, Figure 1-2 and Figure 1-3 illustrate an inherent reality: leading studies suggest an extremely high degree of variability and uncertainty associated with the emissions impacts of EVs.

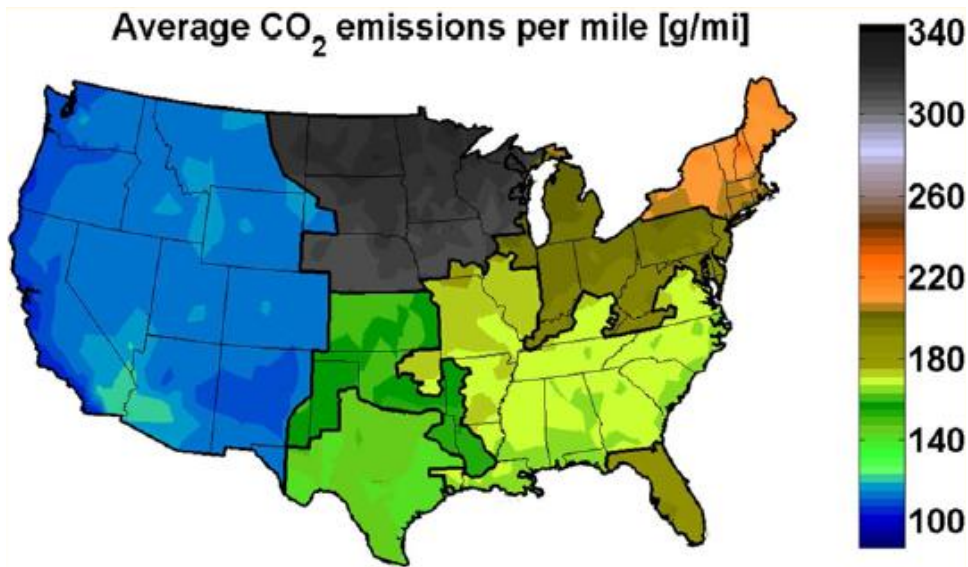

Figure 1-2. National variation of CO₂ emissions from a typical light duty Electric Vehicle [11]

Note: results are reported in gCO_{2eq}/MILE

System-Equivalent CO₂ Emissions by Vehicle Type and Locality

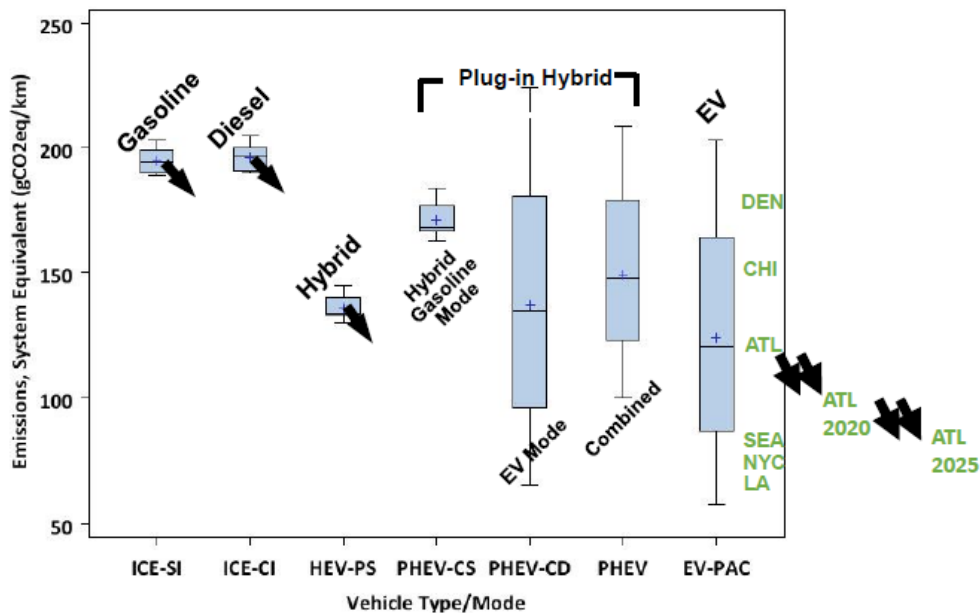

Figure 1-3. Variation across the 23 most populated US cities for CO₂ emissions (in gCO_{2eq}/km) from various light-duty vehicles. With 2020/2025 projections for Atlanta (ATL) [13]

Even when certain regional characteristics of the generating mix or the local climate are considered, researchers have traditionally constrained their modeling in ways that limit their

accuracy and usefulness under deep deployment scenarios [e.g., 3, 9-11, 13]. Some of the common simplifying assumptions often involve the following:

- Simplifying assumptions involving vehicles:
 - Single vehicle model and architecture type (e.g., Nissan Leaf only)
 - Simplified use case for vehicle energy demand (e.g., City and Hwy EPA dyno schedules only, and thus less accurate for real-world energy consumption)
- Simplifying assumptions involving charging:
 - Simplified charging profiles (e.g., convenience charging only, constant rate profiles, time-of-use charging not fully developed)
 - Locational characteristics of charging not fully developed (i.e., vehicle charging can occur where needed without regard to infrastructure availability)
- Simplifying assumptions involving grid-generated electricity:
 - Exclusive focus on CO₂ (i.e., criteria pollutants are often ignored)
 - Simplified or average spatial CO₂ emission intensity assumptions (i.e., annual average for an entire region)
 - Simplified or average temporal CO₂ emission intensity assumptions (i.e., average for an entire year, or constant throughout a 24-hour day)
 - Distribution constraints or grid-congestion factors are often ignored

While prior research findings have been insightful and appropriate to date, many of the simplifying assumptions that have been made begin to break down when EV fleet market shares exceed their current level (i.e., less than 1% as of 2020). As implied above, the primary limitation of relying upon existing models is that complex interactions between an evolving mix of EVs across a range of applications and electric power supplies from the conventional grid are largely ignored. Even though some current research models may provide qualitative guidance up to larger EV market shares (e.g., about 3% of the overall fleet), data and modeling approaches, developed by the research team, are now available to more fully and concurrently explore several of the above factors. Of the simplifying assumptions above, the research team believes that the largest source of variability and uncertainty rests on assumptions made for the grid and the important aspect of when vehicles are charged during the day and across the seasons. Thus, an investigation that explores these interconnected issues could have significant value and provide stakeholders with timely and quantitative insights having much higher resolution due to the consideration of current and future vehicle-grid interactions. This would shed light upon preferred outcomes and recommendations for regionally tailored EV deployment scenarios with the greatest potential benefits toward 2030 and beyond while minimizing unintended consequences.

1.1 Motivation and Scope

The over-arching goal of this project is to ensure that bankable reductions in CO₂ and pollutant emissions are fully understood and realized, even as EV market penetration scales up (e.g., between 1 and 2 orders of magnitude) through 2030. Integrated vehicle, transportation and

electric power systems research collectively form the framework by which strategic policy outcomes can be met. The scope includes a series of independent sub-system models, an integrated and generalizable model, and the validation of the model via a regional case study (e.g., Georgia). Three primary objectives are envisioned to achieve the goal as follows:

1. Using an integrated system-of-systems model and grid data with high temporal resolution (i.e., hourly, seasonally, and annually out to 2030), the study characterizes net emissions from EVs for a representative vehicle classification across a range of driving profiles. The study will compare EVs under varying scenarios to conventional ICE and hybrid vehicles.
2. The study conducts a series of scenarios by which key sensitivity parameters can be better understood. For instance, in a regional case study, the effect of charging time and location (e.g., residential vs. workplace) is explored. Additional parameters are considered, such as the rate of charge (e.g., Level 1 vs. Level 2), and the emissions levels of CO₂ as well as a few key criteria pollutants.
3. Conduct some preliminary translation of the findings toward possible implications upon next steps, including the need for targeted consumer education, the translation of results to help inform policy, and a growing interaction between the disparate communities of stakeholder groups (e.g., automakers, charging companies, utilities, consumers, policymakers) that can maximize key environmental benefits of EVs and inform strategic EV/grid resource planning and decision-making by policymakers based upon rigorous and unbiased analyses that leverage novel vehicle-grid convergence research.

This research is directly relevant to sustainable transportation, and the scope of the 2021-22 NCST solicitation, in that U.S. transportation remains reliant upon petroleum for more than 88.5% of its primary energy resources [14]. While great strides are being made to decarbonize the electric power sector, still less than 0.1% of U.S. primary energy that propels transportation derives from the grid. Amid large investments by utilities and OEMs, and ambitious state and Federal policies, more rigorous and timely guidance is essential for EVs to sustain progress toward their overall promise of reduced environmental impacts. Research guidance that will determine the effectiveness of this technology in 2025 and 2030 is urgently needed now. Having completed the activities enabled by the NCST grant, the research team believes that the methods, initial results, and implications of the findings are uniquely positioned to address critical gaps and inform strategic decisions that will favorably advance EVs, sustainable transportation solutions, and their concomitant policies.

2 Methodology

This research requires the synthesis of three independent models developed uniquely by the research team in the areas of (a) vehicle propulsion to satisfy prescribed trip/travel demands for a range of vehicle technologies, (b) EV charging profiles to reflect typical approaches for light duty vehicle use cases, and (c) grid generation dispatch with commensurate consideration of emissions intensities for CO₂ and major criteria pollutants. The team has an established track record of developing high-fidelity sub-system models and applying them to both generalizable and regional scenarios. The team has leveraged more than three years of prior efforts, during which time we acquired and conditioned open-source data and amassed specifications for five representative alternative vehicle architectures, customized datasets for regional electric power dispatch (e.g., 2018, 2023, and 2030), and numerous travel route pathways. The scope of this project is to update and develop new, more accurate sub-system models and datasets that are relevant, representative, and granular. As described in the original proposal, the team has leveraged these data and iterated upon prior sub-system models with the express purpose of devoting focused attention to integration, simulation, and assessment of results and implications. The end result, therefore, is an integrated model that pulls high-fidelity data from real-world use cases to generate a range of simulations. The simulations will be primarily used to draw comparisons, understand the impact of fundamental assumptions around charging behavior and grid emissions, and develop initial guidance around the relative merits of EVs under representative use cases.

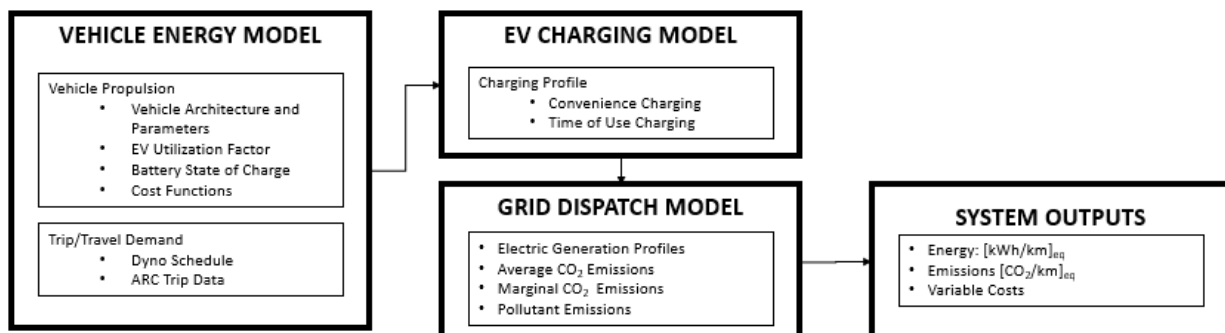

Figure 2-1. Integrated modeling methodology for combining vehicle, grid, and emissions considerations for simulation.

The first step in the analysis is the refinement of physics-based vehicle energy consumption models that permit comparison of a range of vehicle architectures that utilize energy from disparate primary sources (e.g., gasoline vs. grid electricity). A parallel task is to impose upon the vehicle propulsion model a range of driving cycles that can best approximate typical characteristics of representative use cases. Our methodology affords access to established data and extends prior vehicle propulsion energy and emissions analyses [9-10, 13]. As a parallel input, the team has utilized individual EPA dynamometer schedules, replicated the 5-cycle fuel economy label weighting protocol, and also consulted independently derived travel demands from representative use cases [e.g., 15-16, Figure 2-3]. A detailed discussion of the theory, model development, source data, and initial applications can be found in [13]. Minor

adjustments have been made to vehicle modeling to accommodate key vehicle classifications of interest (i.e., LDV ICEV, HEV and EV), and to ensure appropriate reasoning to walk from prescribed EPA dyno schedules to the 5 cycle weighted means, and further to practical interpretations of household travel for representative use cases [17].

2.1 Vehicle technology categories

As discussed above, we adapt the physics-based powertrain models developed in [13] to accommodate target vehicle technologies of interest. This includes baseline vehicles (e.g., gasoline-consuming ICEV and HEV), as well as electrified powertrains (e.g., PHEV and EV). For the purposes of this study, only pure battery electric vehicles (BEV) have been evaluated. However, all relevant LDV vehicle technology models have been developed and coded, meaning PHEV analysis is readily available and may be of interest. Owing to their unique architecture which operate as both HEVs and EVs, depending on the battery state of charge, the environmental impacts of PHEVs can be estimated as a weighted mix of the individual impacts of HEVs and EVs respectively.

To facilitate a direct comparison among vehicles using dissimilar energy sources, we identify vehicle specifications for a given light-duty vehicle classification and hold constant key parameters such as vehicle power output, vehicle footprint, passenger and cargo capacity, and so forth. Table 2-1 below depicts some of these operative specs. Note that some differences are inherent in other categories, such as vehicle curb weight. But these have been left as specified by the OEM, under the argument that mass-production specs are reflective of the current state of the art and therefore an excellent proxy for the inherent tradeoffs or interactions to deliver vehicles of similar performance.

Table 2-1. Specification table for the different vehicle architectures compared in the study [13]

Vehicle Type:	ICE-SI⁷	ICE-CI⁸	HEV-PS⁹	PHEV-40¹⁰	EV-PAC¹¹
Source:	[8 ^{a,b,c}]	[8 ^d]	[8 ^a]	[8 ^e]	[8 ^f]
Vehicle Attribute					
Vehicle mass ¹ [kg]	1438	1595	1519	1857	1610
Drag coefficient	0.29	0.30	0.25	0.29	0.28
Frontal area [m ²]	2.12	2.10	2.17	2.16	2.31
Engine power ² [kW]	108	104	73	63	-
Electric motor power ² [kW]	-	-	60	111	80
Total vehicle power ² [kW]	108	104	100	111	80
Battery mass ³ [kg]	-	-	45	198	294
Battery capacity ³ [kWh]	-	-	1.3	16.5	24.0
Fuel economy ⁴ [US ⁵ mpg]	31.4	34.0	50.0	37.0	-
Fuel consumption ⁴ [L/100km]	7.5	6.9	4.7	6.4	-
Elec. consumption ⁶ [Wh/km]	-	-	-	214	184
Equiv. fuel econ. ⁶ [mpge]	-	-	-	98	114
All electric range [km(mi)]	-	-	-	64(40)	134(84)

1. Vehicle mass reflects “vehicle inertia weight” (curb weight plus 136kg per EPA rule).
 2. Engine and motor power represent maximum rated values reported by OEMs at vehicle-specific engine or motor speeds. Total vehicle power applies to HEV and PHEV and reflects the maximum net combined propulsion of engine and motor.
 3. Battery mass and capacity represent complete battery modules.
 4. Fuel economy, consumption, and range values reflect 5-cycle EPA combined ratings [13].
 5. This study uses U.S. gallons (not imperial) in all fuel economy MPG references.
 6. Electricity consumption is on a vehicle, not system, basis, and is derived by dividing the energy content of a gallon of gasoline (33.7 kWh) by the EPA-reported equivalent fuel economy in MPGe.
 7. The key specifications for three top-selling models (Toyota Corolla, Honda Civic, and Ford Focus) were averaged to represent a baseline non-aspirated ICE-SI (where SI = Spark ignition).
 8. Volkswagen Jetta Value Diesel (ICE-CI, where CI = Compression ignition).
 9. Toyota Prius (HEV-PS, where PS = Power split).
 10. Chevrolet Volt (PHEV-40, where 40 represents the all-electric range in miles).
 11. Nissan Leaf (EV-PAC, where PAC = Passively air cooled).
- Other vehicle specifications such as engine maps and motor performance, battery cell parameters, and physical or operational characteristics have been obtained from either OEM fact sheets or the literature [8a-f].

2.2 Driving cycles

The five distinct driving cycles that comprise the EPA test and labeling protocol are well-documented and widely used for comparative analyses [15]. The three 23°C (75°F) tests include a derivative of the Urban Dynamometer Driving Schedule (UDDS) known as the Federal Test Protocol (FTP), the high-acceleration aggressive driving schedule identified as the Supplemental FTP (US06), and the Highway Fuel Economy Driving Schedule (HWFET). The 35°C drive cycle is the Air Conditioning Supplemental FTP driving schedule referred to as SC03. The -7°C cold weather test schedule repeats the original FTP at the reduced temperature.

As mentioned, the study has adopted the EPA “5-cycle” protocol and created an approach whereby a weighted mix of driving schedules is obtained to approximate major modes (e.g., city, highway, combined). Please see Appendix A for more details about the weighting of the constituent driving cycles, and the governing formulae.

With the original development of the vehicle architecture models, and assumptions around the weighted driving cycle protocols, the team’s next step was to develop a MATLAB/Simulink code that generated a series of energy consumption values based on inputs of vehicle type and driving cycle. These intermediate outputs were then combined to generate effective fuel economy values, analogous to the EPA 5-cycle approach, for the stipulated categories (city, highway, combined). This was done and a set of energy consumption outputs were generated. These outputs are depicted in Table 2-2.

Table 2-2. Effective fuel economy values

	ICEV (mpg)	HEV (mpg)	EV (kWh/mi)
City	28.67	55.79	0.24
Highway	38.64	48.76	0.32
Combined (Wts: 0.43 city, 0.57 highway)	33.61	51.55	0.29

2.3 Mapping to representative commute categories

The final step was to consult the DOT household transportation survey and refer to resident expertise within the research team (i.e., Rodgers) to determine some representative driving cycles for metro Atlanta. We select two urban commutes of 80.5 km (50 miles) and 32.2 (20 miles), and a suburban vehicle use case of 48.2 km (30 mi). For the urban commutes, presumably into and out of a city like Atlanta, it is reasonable to employ the EPA “combined” rating and protocol to determine energy consumption for these trips. For the suburban errand use case, it is reasonable to employ the EPA “city” rating and protocol. This is summarized in Table 2-3 below. Shown in Figure 2-2 is a notional depiction of a baseline vehicle’s instantaneous power and cumulative energy for an example drive cycle. Figure 2-3 depicts a few of the standardized EPA dyno schedules that are fed into a 5-cycle weighting determination.

Table 2-3. Representative commutes developed for the comparative scenario analysis

Commute Description	Total Daily Distance Traveled km (Miles)	Relevant EPA fuel economy category/calculation used
Urban Commute (moderate)	80.5 (50)	“Combined”
Urban Commute (short)	32.2 (20)	“Combined”
Suburban Errands	48.3 (30)	“City”

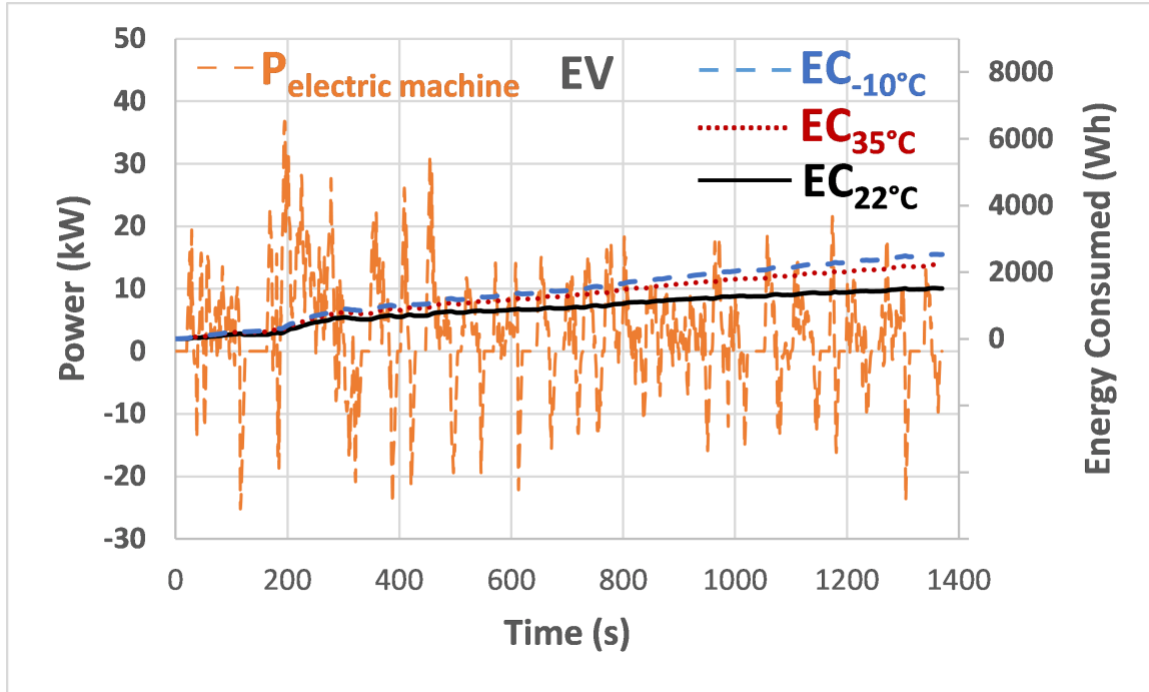

Figure 2-2. Fundamental powertrain model specific to each vehicle architecture (ICEV output shown for reference) [8]

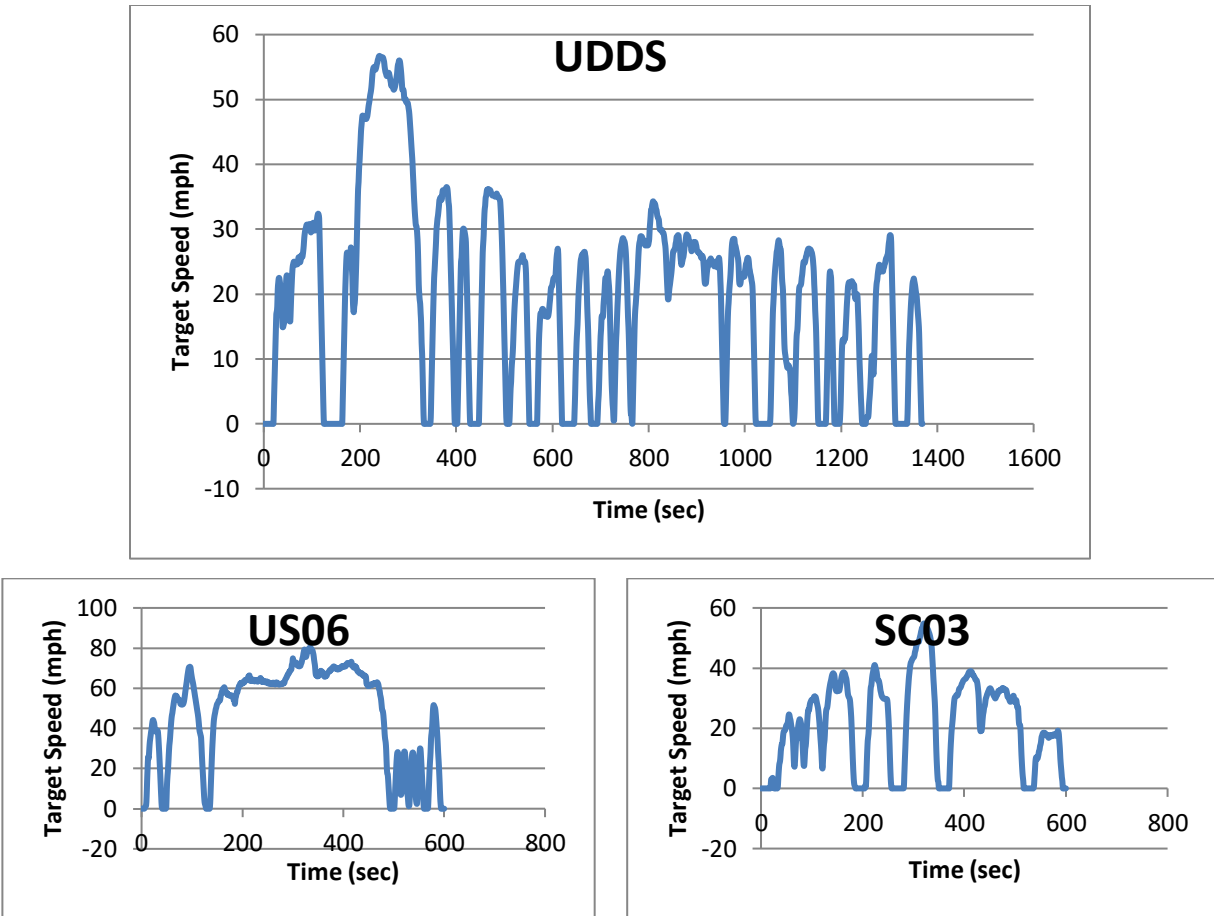

Figure 2-3. Basic EPA dyno schedules (UDDS, US06, and SC03 shown for reference).

2.4 Models & Sources of Data

This section briefly recaps the major sub-system models that are integrated in the present work. For the vehicle model, physics-based powertrain models are developed in [13] to accommodate target vehicle technologies of interest. These models utilize initialization parameters for official OEM specifications for these vehicles of interest as generally depicted in Table 2.1 and [13]. Five distinct driving cycles are then imposed for the selected vehicle models. This study utilizes the first key dynamometer cycles that comprise the EPA test and labeling protocol, which are well-documented and widely used for comparative analyses [15]. The output of the combined vehicle and driving cycle modeling then generates fuel and energy consumption data at the boundary of the vehicle system. The final steps are to incorporate electric vehicle charging profiles, map them to characteristic daily use cases, and estimate their energy and emissions impacts by considering upstream electric grid modeling efforts. These steps and the relevant models and data are described in Sections 2.5, 2.6 and 2.7.

2.5 Overview of EV charging profile development and simplified use cases

Regarding EV charging behavior, we consider about four primary sources of data to establish representative EV charging profiles. Two are explicitly for residential charging, one is explicitly

for workplace charging, and the fourth speaks with survey data collected for both and other categories (e.g., public charging). The authors acknowledge that there is a growing body of literature on the subject of charging behavior by numerous transportation research centers of note (e.g., NREL, Escalent [23], NCST UC Davis [27], among other examples). The authors further suggest that the approach taken herein is appropriate for the purposes of these comparative analyses. It is of note that this research study draws from a combination of analytical and empirical sources of information and data to develop its charging profiles and use cases. Included in this, as detailed below, are first hand studies by researchers involved in the study, utility rate structures that are specific to EV users in the target region, and real-world observed EV charging behavior for a selected network in downtown Atlanta. None of these is unique, and similar approaches are used elsewhere. This, this approach is intended to demonstrate the types of sources of data that this methodology may leverage, and to showcase how they may be applied in a representative set of simulations and outputs.

As a first step, we refer to synthetic data generated by a separate research team from Georgia Tech that is evaluating the benefits and challenges associated with smart charging algorithms. [20-21]. Second, we consult the Georgia Power Electric Vehicle Rate scheme, which provides customers with EVs at a deeply discounted rate during off-peak times. In exchange, the rate is tiered, with a relatively expensive energy rate during summer afternoons, and then a fairly nominal price during all other times of the day/year [22].

Third, we refer to data from a ChargePoint dashboard portal and database that has been aggregated for workplace charging on the Georgia Tech campus since about 2015. An example of some of this data for a sample month (Feb 2020) is presented below. It is noteworthy that typical workplace charging occurs in two waves: morning and immediately following the noon hour. A part of the explanation for this has to do with policy: the GT Parking administrator provides a much lower rate for the first 4 hours and then adjusts this to severalfold higher to incentivize the EV owner to vacate the parking space and permit additional EV owners an opportunity to charge. This policy is important as it suggests that behavior will strongly respond to financial signals. The dashboard data is extremely valuable in providing statistically significant information (over a period of 5 years), that can inform real, not perceived or stated, preferences.

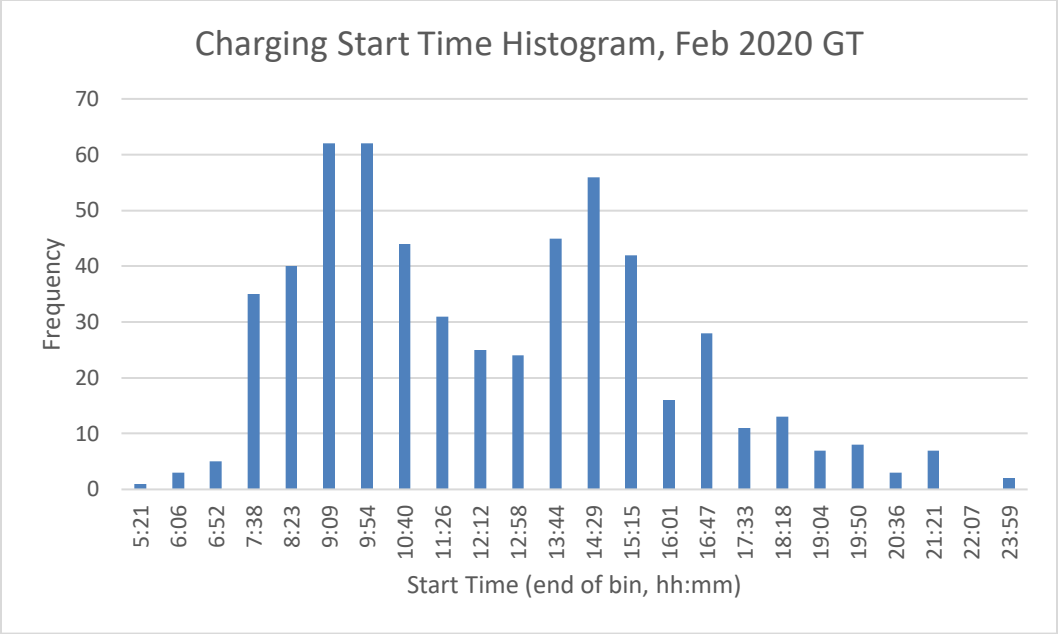

Figure 2-4. Example workplace charging data of EV charging events on Georgia Tech campus from February 2020

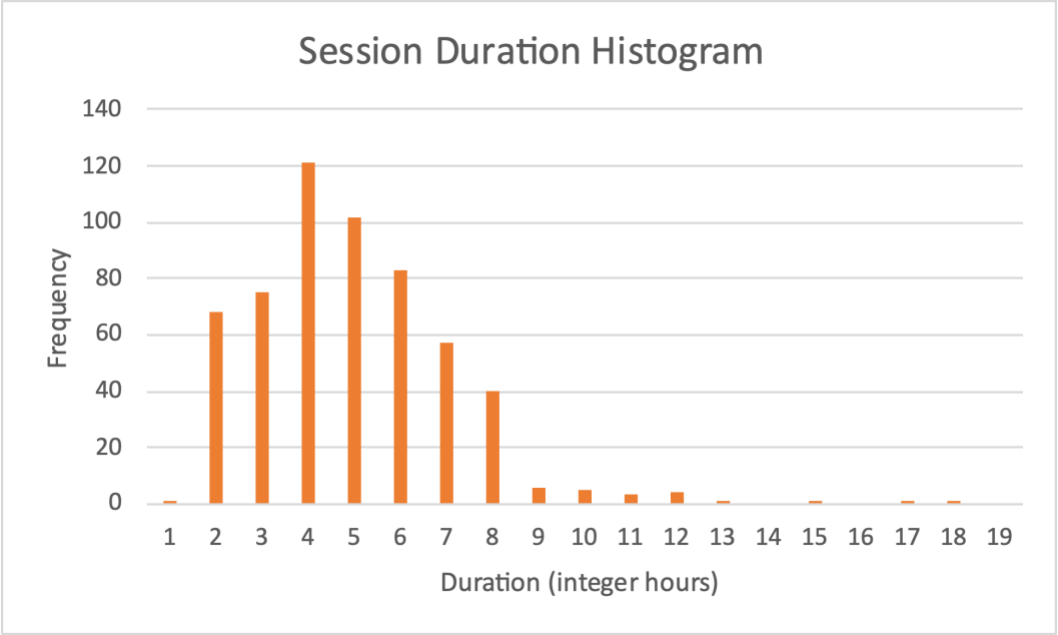

Figure 2-5. Example workplace charging session duration on Georgia Tech campus from February 2020

Finally, our research team conducted a verbal consultation with a third-party research firm, Escalent [23]. This conversation provided insight into when EV owners are most likely to be charging their EVs as recently as 2021. The following Figure 2-6 captures some of the relevant info that has been mined to inform assumptions and representative profiles for EV charging.

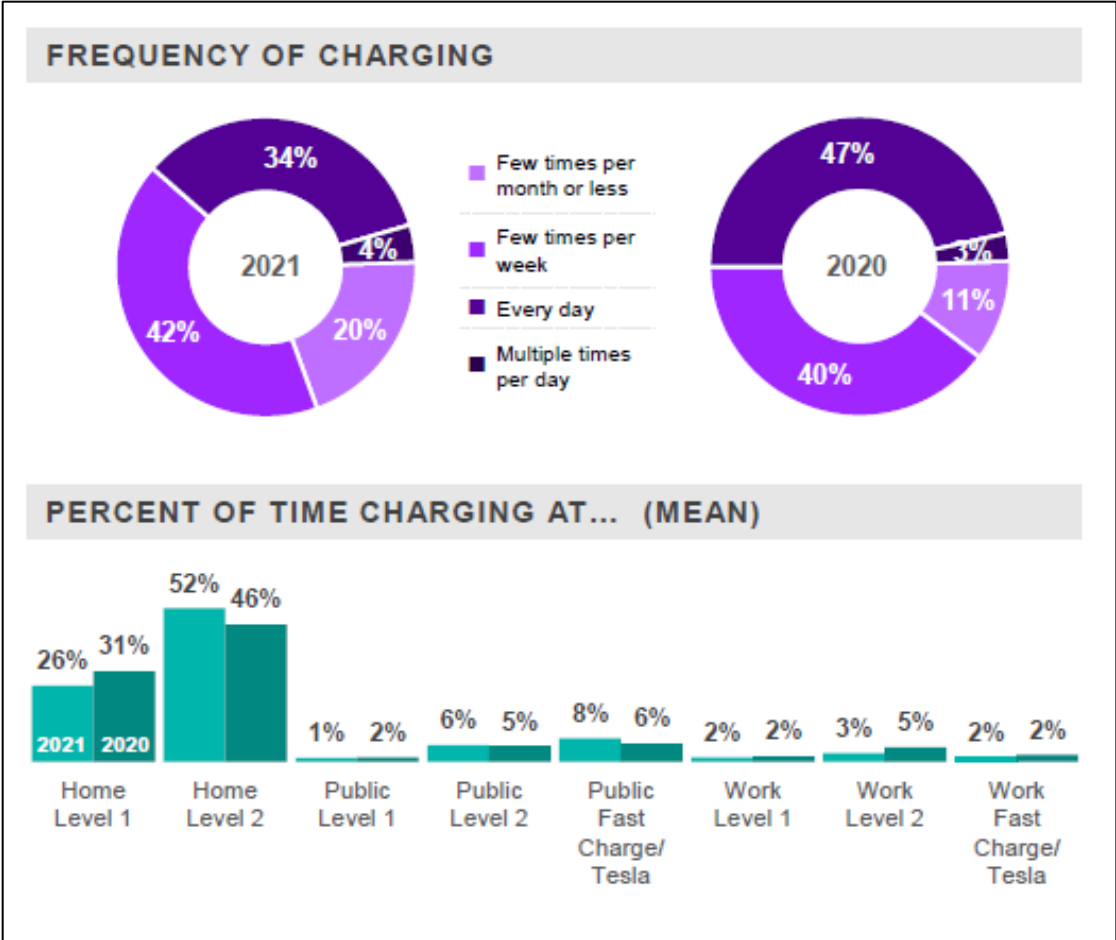

Figure 2-6. Example of 2020 survey data characterizing EV charging behavior provided by Escalent [23]

Of note from the bar graphs in Figure 2-6 above is that close to 80% of individual EV owners charge at home. It is also obvious that for the period 2020-21, most charging events (about 61%) are taking place on a Level 2 charger. Referring now to the purple pie charts, we see that roughly half of EV users are charging their vehicles at least once a day. (Note: the PI acknowledged these data may cover EV behavior that spans both pre- and post-COVID pandemic periods. It would not be surprising if EV charging behavior was irregular and/or reduced. The PI has a pending follow-up request with the third party for some additional feedback on this question but has not yet received an answer.)

2.5.1 LDV residential (overnight, evening)

Based on the corroboration of multiple independent sources of data, the research team decided to define two representative EV charging profiles to govern “residential” behavior. These are simplified for the analysis but considered highly reflective of actual behavior. The EV profiles are depicted in Figure 2-7 below. The team opted to assume Level 2 chargers were used for the simulations in this study.

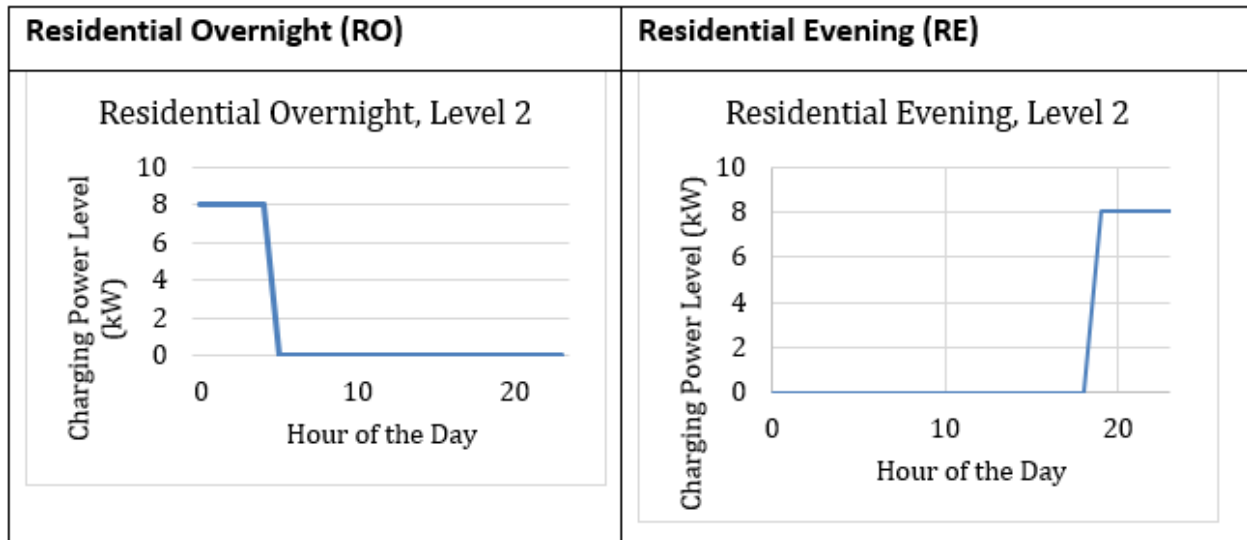

Figure 2-7. Examples of residential EV charging profiles used in the study

Based on the combined input and the author’s judgment, Level 1 residential charging profiles were also designed and used for additional simulations. These Level 1 residential charging profiles can be seen in Appendix B.

2.5.2 LDV workplace (morning, afternoon)

Again, based on the corroboration of the aforementioned independent sources of data, the research team also defined two representative EV charging profiles to govern “workplace” behavior. These are simplified for the purpose of the analysis, and similar to the residential cases, are considered highly reflective of actual behavior. These EV profiles are shown in Figure 2-8.

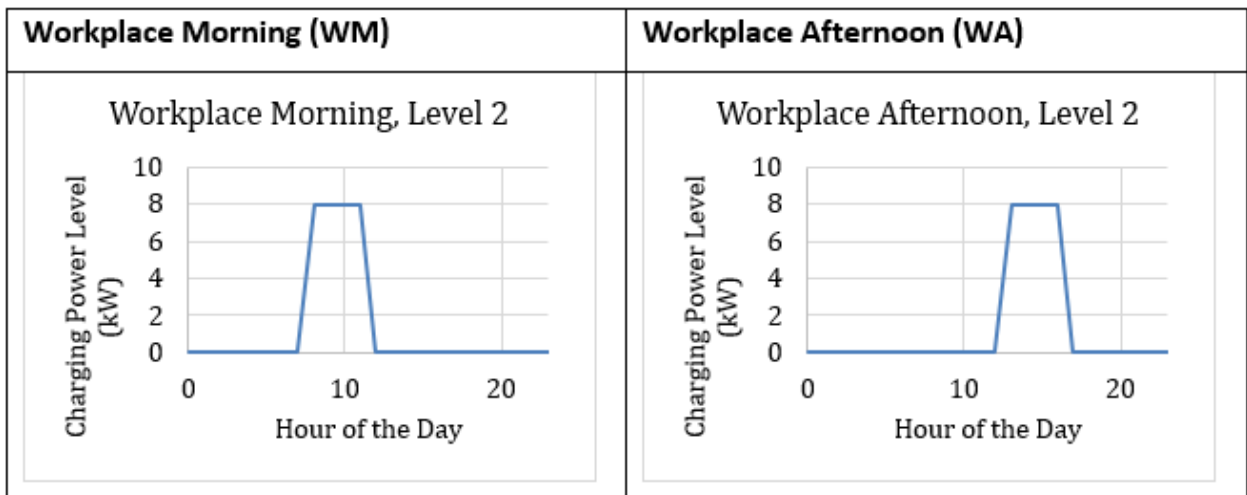

Figure 2-8. Examples of workplace EV charging profiles used in the study

2.6 Overview of grid emissions vs. tailpipe emissions

One of the team's most significant contributions has been to leverage and extend grid modeling and optimization work [13,18-19]. In prior work, energy storage scenarios and their associated CO₂ impacts were determined for various use case scenarios in a Southeastern regional context. A merit-order dispatch estimation has been developed and iterated based on actual data for the Southern Company Balancing Authority (also known as the Southeast Reliability Corporation/Southeast, or SERC/Southeast). These data are high resolution (hourly) and provide excellent detail of the individual plants and generating units for all technologies. The team has consulted official public sources of data that are disclosed in [9,18,20,22,24,25,26].

The PI worked closely with a Georgia Tech graduate student on a related project to explore and adapt a methodology based on [24]. The student and PI, along with a few additional co-authors have recently presented a published conference paper that describes the approach [25]. Some supporting information is included in the Appendix to summarize the method for marginal grid emissions estimation.

Toward the primary objective of the present study, the team determined that it would be most useful to define a series of grid emissions assumption approaches as follows:

- **Annual average.** By this assumption, the CO₂ emissions intensity is estimated as the cumulative CO₂ emissions for a given region divided by the cumulative electric power generation for the region, on an annual basis (i.e., CO₂_annual-total/kWh_annual-total). This emissions intensity has been a commonly used metric in policy studies and is generally estimated for an entire balancing authority (e.g., Southern Co, TVA, PJM, etc.).
- **Monthly average.** This assumption attempts to consider the impact of seasonal variation within a balancing authority. As such, a monthly average assumption for CO₂ emissions intensity is estimated as the cumulative CO₂ emissions for a given region divided by the cumulative electric power generation for the region, on a monthly basis. (CO₂_monthly-total/kWh_monthly-total). This emissions intensity has been used in recent research studies to better understand the impacts of seasonality as it relates to electric power supply and demand. Like the annual approach, it is generally estimated for an entire balancing authority (e.g., Southern Company, TVA, PJM, etc.).
- **Hourly weighted mix.** This assumption takes into account the mix of electric power generation by hour for a given balancing authority. It relies upon much higher temporal resolution data sets that are now being tracked and reported publicly by government agencies (esp. DOE/EIA and EPA). For each of the year's 8760 hours within a given balancing authority, cumulative CO₂ emissions from all sources are divided by the cumulative electric power generation for the same hour. It reports on the mix as evidenced by historical data. This is done at the level of the balancing authority, but also at other levels.
- **Marginal hourly weighted mix.** This approach considers the idea that certain sources of electric power generation are more or less likely to be used to meet marginal demands on an hourly basis, within certain grid constraints. This is, in fact, quite representative of

how the grid operates; a dispatcher responds to changing signals for demand and adjusts supervisory supply decisions to accommodate them. In this case, there is a subset of generating resources in the hourly mix that can actually be “controlled” and “dispatched” to meet rising or falling demands. It is a key goal of this study to better understand the implication of this reality on the CO₂ emissions that are experienced by a given EV charging event. A related goal is to promote more interaction within the interdisciplinary research community related to the limits of existing and future grid constraints on dispatchers ability to meet new and/or uncertain loads, including EVs. In the marginal hourly weighted mix assumption, we have applied a statistical approach, disclosed in detail in [24-25]. To recap, historical trends are inferred by month and hour to estimate the weighted mix of dispatchable generation resources. These are predominantly fossil-based, and therefore higher in CO₂ than the overall grid mix; but they are also more capable of being predictably ramped up and down to meet load. The CO₂ intensity is then the cumulative CO₂ emissions from the marginal dispatchable resources for a given hour divided by the cumulative electric power generation from these sources for the same hour.

- **Marginal resource X.** Continuing further on the marginal hourly weighted mix approach immediately above, this approach considers the eventuality that a specific generating resource (down to the plant and unit level having a specific fuel or energy source and a specific conversion technology) is ultimately responsible to meet the marginal electric power demand of an EV which charging. This assumption could be true when EV demand constitutes either a reasonably large or a reasonably uncertain share of near-term demand requirements. These conditions may persist in the near future as EV market share reaches significant levels overall, quickly, without appropriate signals between utility and customer, or without duly substantiated charge management protocols. Here the CO₂ intensity represents the cumulative CO₂ emissions from the single generation resource that is most likely dispatched to meet the marginal electricity demand within a given hour. This assumption yields the greatest hour-to-hour variance when compared to other assumptions, since a range of resources may be used to meet the marginal demand of an additional kWh of load based on several external factors. Its variance is exacerbated by high-power, and short-duration charging events (e.g., Level 3 DC Fast Charging DCFD). The bottom line here is that as EVs are deployed and the grid is modernized, there are near- to intermediate-term conditions pending (e.g., through 2030) which are likely to add variability and uncertainty at the intersection of high-power charging events and the need for the grid to respond. The expansion of the high-power, short-duration charging events may be propelled by Level 3 buildout (e.g., NEVI infrastructure and interstate corridor installations), and suggest that predicting emissions from EVs will require a more nuanced understanding of how the grid meets marginal, uncertain, or high power, short duration loads.

2.7 Overview of system integration and emissions aggregator

The team has developed a system-of-systems model that enables the integration of the three sub-system models described in this section. Doing so enables comprehensive and quantitative

simulations of EV deployment for multiple driving cases, under varying EV charging and grid scenarios.

The produced MATLAB/Simulink model consists of two user-loaded look-up tables for the selected grid emissions profile and EV charging profile that are imported using the initialization code. The look-up tables take the form of a time series with 1440 distinct time stamps, equal to the number of minutes in a day. The emissions profiles available to the team consisted of hourly emissions rates. The emissions rate during a given hour was assumed to be the same for each minute in that hour. In this manner, each hour of emissions was dissected into 60 periods to achieve 1440 rows of data. By creating minute-by-minute lookup tables, the model is able to stop accumulating grid emissions the same minute the vehicle's battery is recharged, minimizing returns of surplus charge.

Besides loading look-up tables, the initialization code also provides an opportunity for the user to calibrate the energy target (i.e., how much energy has been depleted from the battery that needs to be replenished). For this study, the energy targets were calculated for each simulated use case using our Vehicle Energy Model described in the previous section.

The initialization code and input parameters utilized in this study can be found in Appendix C.

Once the initialization code is run, the Simulink component of the model references the loaded look-up tables and parameters, integrating the sub-system models using a series of logical arguments. The completed simulation provides an aggregated output that describes the cumulative grid emissions attributed to the simulated recharge event. These emissions totals are easily converted to a per-unit distance rate. The architecture of the Simulink model can be seen in Figure 2-9.

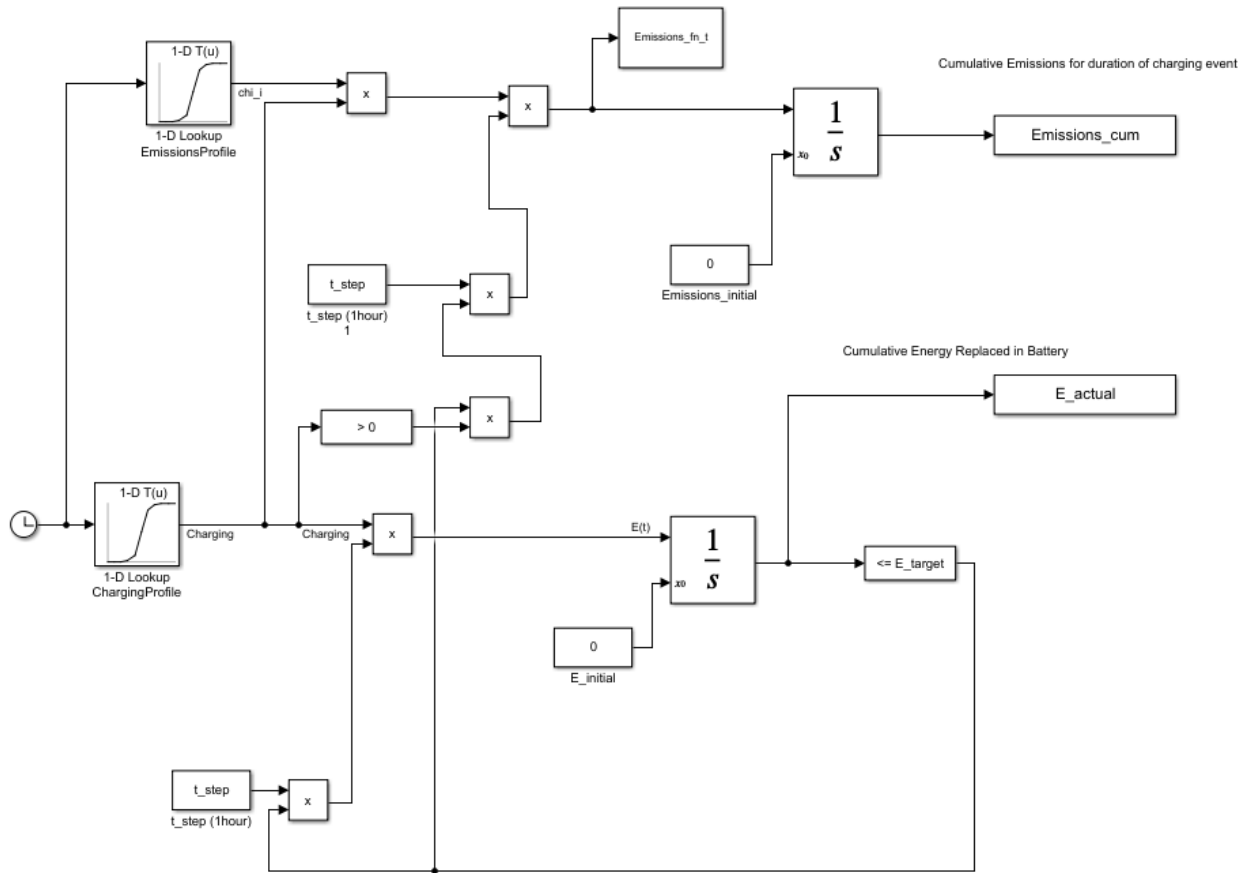

Figure 2-9. Energy and emissions integrator (Simulink)

The results of these simulations are presented in the next section and yield a first-of-a-kind distribution of projections for CO₂ emissions and criteria pollutants. As a step to quantify these, energy consumption has been computed as an input variable. The team believes the method is robust and readily capable of scale-up and enhancement for use in other regions and in larger or smaller jurisdictions of interest. A goal is to better understand the current impacts of transportation energy use and emissions under various growth scenarios. A secondary eventual goal is to use this method to forecast future grid and EV adoption states to educate and inform the public and key decision-makers.

3 Results and Discussion

A series of scenarios were developed and simulated in the system-of-systems model described above. Table 3-1 defines the variables from which the example scenarios were crafted and, where applicable, their abbreviations. A simulation was conducted for every possible combination of variables for a representative day in August, October, and December 2018¹. A total of 258 simulations were run for this analysis.

Table 3-1. Variables included in the system-of-systems modeling approach

Vehicle Type	Energy Consumption	Charging Profile	Emissions Profile
EV	Long Commute – 80.5km (50mi), 16.5 kWh	Residential Overnight (RO) - 12AM to 5AM	Annual Average (A)
ICEV	Short Commute – 32.2km (20mi), 6.59 kWh	Residential Evening (RE) - 7PM to 12AM	Monthly Average (M)
HEV	Suburban Errands – 48.3km (30mi), 8.18 kWh	Workplace Morning (WM) - 8AM to 12PM	Hourly Average (H)
		Workplace Afternoon (WA) – 1PM to 5PM	Hourly Marginal Mix (HMM)
			Hourly Marginal Resource X (HMRX)

Figure 3-1, Figure 3-2, and Figure 3-3 are comparative visualizations of simulation outputs (CO₂ emissions per kilometer). The purpose of these figures is to depict increased or abated CO₂ emissions under different emissions profiles and charging assumptions for different trip types at different times of year relative to an ICEV baseline. To enable such apples-to-apples comparisons, the energy demanded for each trip for the ICEV baseline was derived using standard EPA-weighted fuel economy mixes (city, highway, and combined) and converting the total gasoline consumed to kWh at a rate of 33.7 kWh per gallon of gasoline. The EPA combined fuel economy mix was used for both the Long Commute and Short Commute trips, while the EPA city mix was used for the Suburban Errands trip. Tailpipe CO₂ emissions were calculated assuming an emissions rate of 8,887 grams of CO₂ per gallon of gasoline. The same methodology was employed to simulate the HEV scenarios to provide an additional point of comparison.

¹ While 2018 grid data were utilized for the present study to demonstrate how to employ a real-world data, the methodologies are capable of generating simulations for current and future grid conditions equally well. This is considered an important contribution of the present effort.

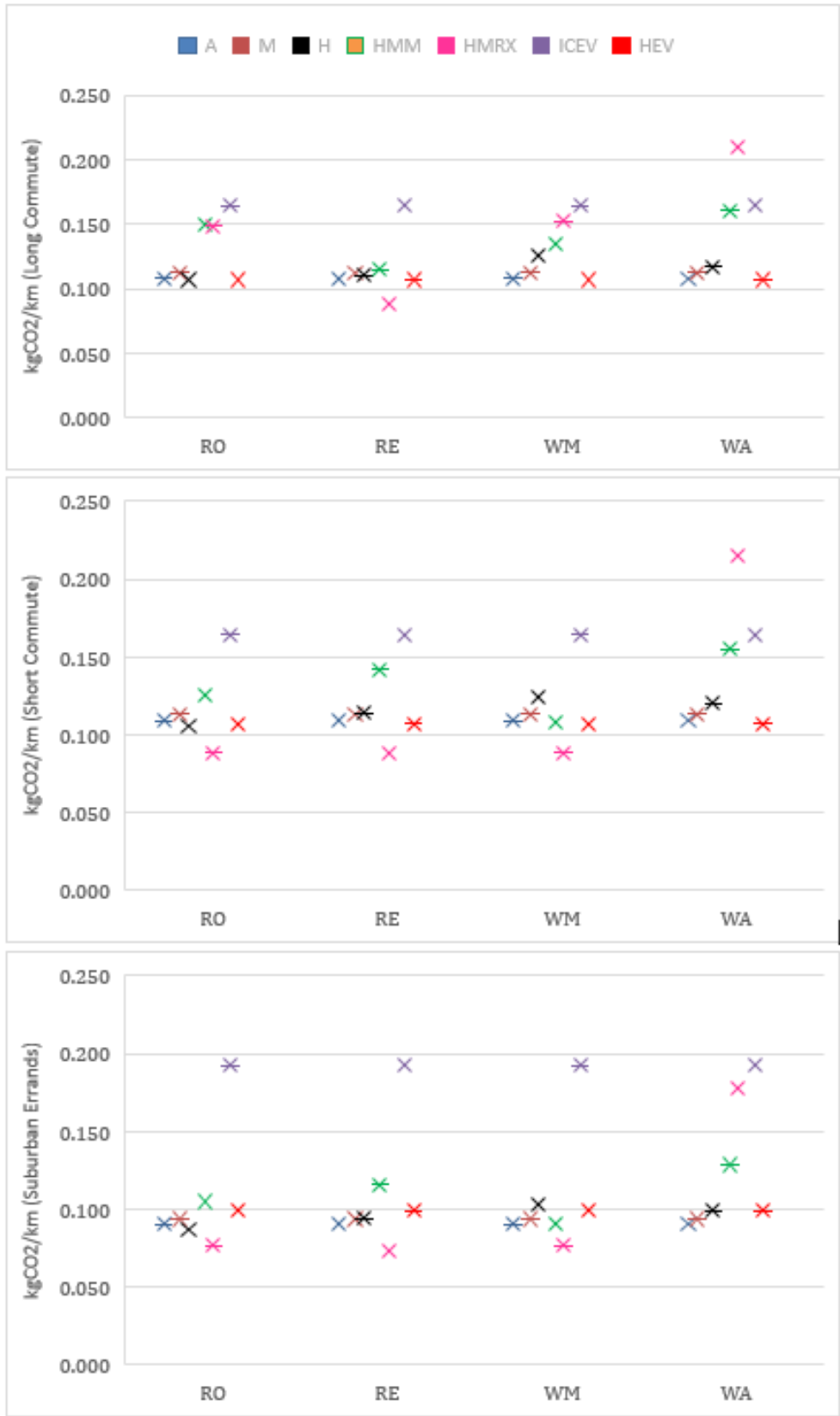

Figure 3-1. CO₂ emissions per kilometer (August)

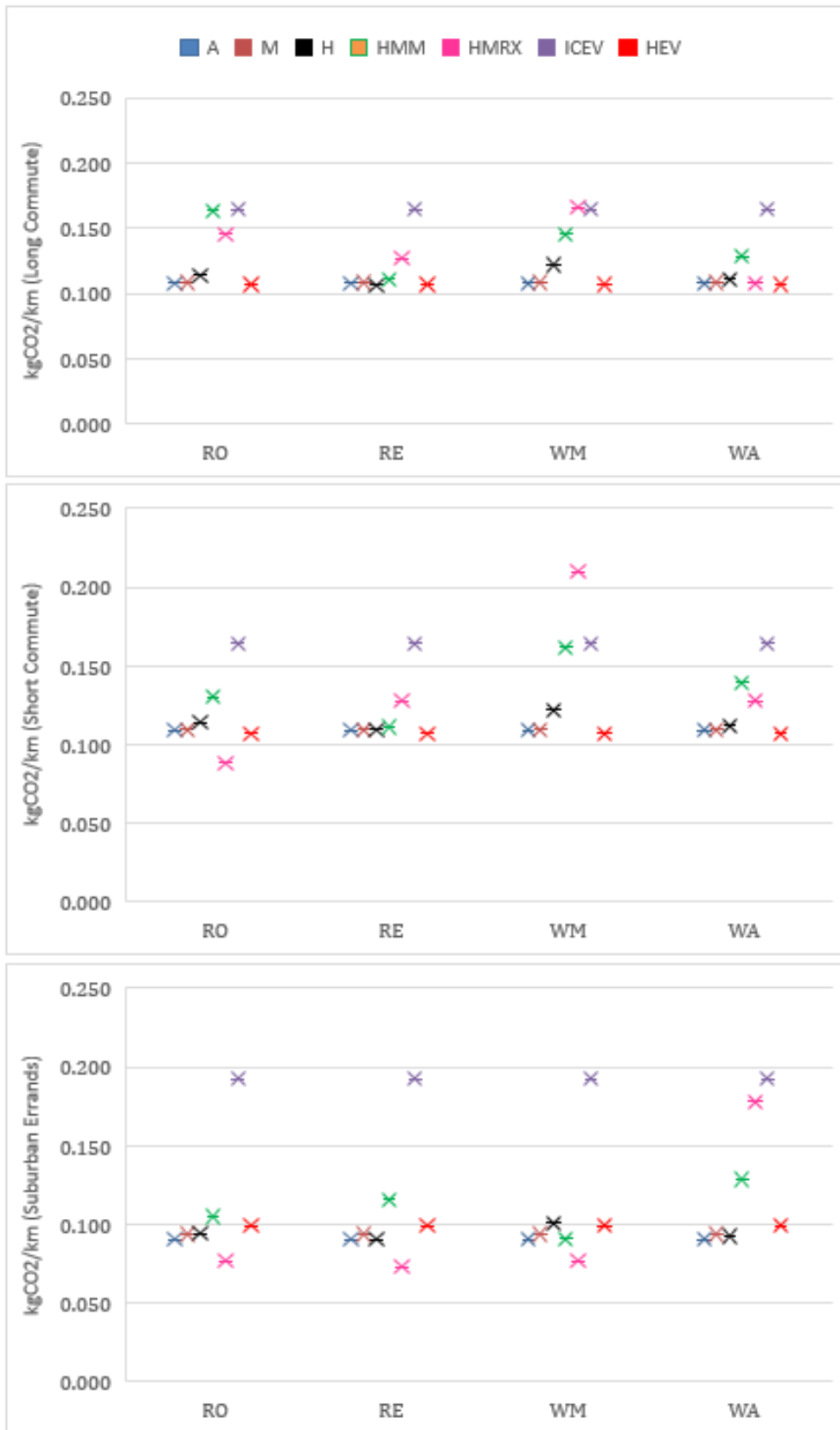

Figure 3-2. CO₂ emissions per kilometer (October)

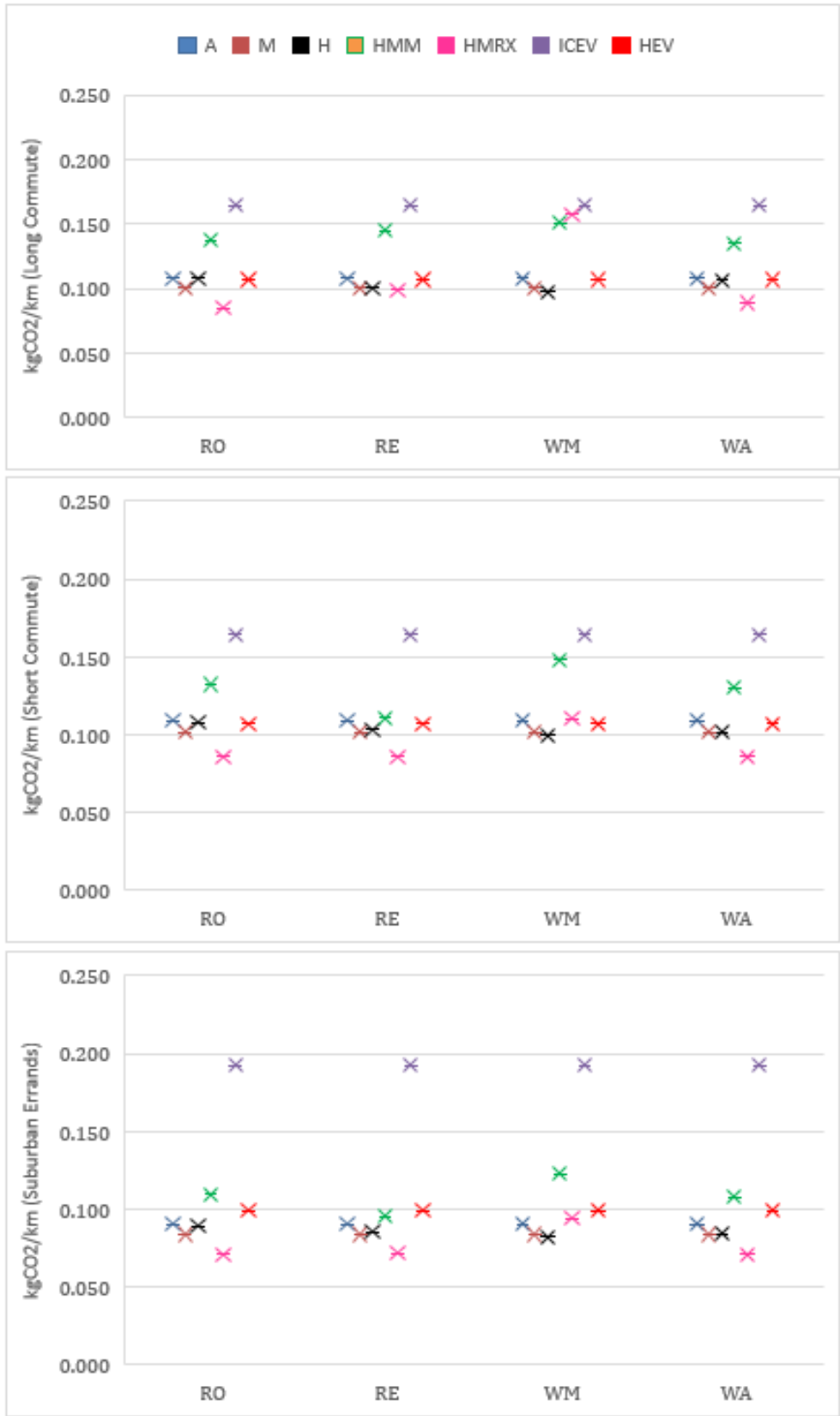

Figure 3-3. CO₂ emissions per kilometer (December)

When comparing resulting emissions rates under each grid assumption, it is immediately clear that accepting a monthly or annual average grid emissions rate fails to capture the significant variance that occurs throughout a given day. At higher temporal resolutions, daily grid emissions profiles begin to emerge that have important implications for finding the true environmental benefits of EVs and how those benefits vary depending on the timing of charging events. On average, CO₂ emissions per kilometer for an EV charged under the Residential Overnight or Residential Evening charging profiles were found to be less than an EV charged under the Workplace Morning or Workplace Afternoon profiles, especially in the summer and shoulder months. For example, an EV performing the Short Commute trip and charging with the Residential Overnight charging profile in August was found to emit over 3% less CO₂ per kilometer when using hourly grid emissions profiles compared to annual averages and nearly 7% less CO₂ per kilometer compared to monthly averages. Additionally, an EV performing the same trip in August but charging under the Workplace Morning charging profile was found to emit nearly 14% more CO₂ per kilometer when using hourly grid emissions profiles instead of annual averages and nearly 10% more instead of monthly averages.

This variance is even more pronounced under the marginal scenarios, though not always with the same directionality. Assuming the Hourly Marginal Mix tends to reduce the per-kilometer CO₂ emissions of an EV charged with the Workplace Morning profile in the summer months, making that charging profile the most attractive in terms of environmental benefit in some cases. Under Hourly Marginal, Resource X assumptions, the CO₂ emitted per kilometer for an EV can vary as much as 58% depending on the time it is charged on a given day.

Importantly, almost all simulated EV scenarios realized reduced CO₂ emissions per kilometer compared to ICEVs. However, the magnitude of these reductions varies substantially under different emissions assumptions, charging profiles, and seasons. The extreme hourly and seasonal variations in effective emissions rates of EVs found in this study indicate that reliance upon annual or monthly average emissions rates for the modeling of EV environmental benefits is inadequate. Table 3-2 depicts the wide variation in emissions rates from simulation to simulation relative to the ICEV baseline.

Table 3-2. Percent improvement in CO₂/km over ICEV baseline for the Long Commute trip in August

Use Case	August			
	Charging Profiles			
	RO	RE	WM	WA
Commute (80.5km)				
H	-34.81%	-32.59%	-23.03%	-28.84%
M	-31.57%	-31.57%	-31.57%	-31.57%
A	-34.08%	-34.08%	-34.08%	-34.08%
ICEV	0.00%	0.00%	0.00%	0.00%
HEV	-34.80%	-34.80%	-34.80%	-34.80%
HMM	-8.47%	-30.03%	-17.96%	-2.03%
HMRX	-9.57%	-46.20%	-7.10%	27.86%

Average emissions rates at lower resolutions obscure vital information that could otherwise be used to optimize environmental benefits as well as inform policy. Effective communication of hourly or higher resolution of grid CO₂ intensity would help the consumer make an informed choice on when to charge their EV to maximize environmental benefits. With the maturation of “smart-charging,” enabling communication between the grid or utility and smart charger units would allow the smart charger to control the rate of charge to minimize effective EV emissions, subject to user-configured constraints involving required time of use, desired battery capacity, and cost.

An additional pertinent takeaway from these results is the performance of the HEV. As expected, the HEV reduced CO₂ emissions compared to an ICEV, but it also performed consistently on par or better than many EV scenarios. When annual or monthly average emissions rates are assumed, HEVs already perform better on a per-kilometer basis than EVs beyond a certain distance threshold. These de-facto superiorities of HEVs become less pronounced at certain times when hourly emissions rates are assumed. Failing to understand and incorporate higher-resolution evolutions in grid emissions intensities can lead decision-makers to ill-informed conclusions that could be sub-optimal for reducing environmental externalities. It is worth noting that both EVs and grid generating resources are evolving dynamically, placing renewed emphasis on studies that consider environmental impacts during this transition period (e.g., 2030, 2035).

There is likely some threshold of EV penetration that will trigger a realignment in marginal emissions trends. As electrical power demand increases at peak charging times when consumers are incentivized to charge their vehicles, marginal resources in addition to those observed in this study, will eventually be required to supply sufficient power. Often, due to the inherent need for dispatchability, marginal resources are fossil-based or non-renewable in nature. Thus, if additional marginal resources need to be brought online, it could alter grid emissions profiles and lead to shifting environmentally optimal charging periods. Understanding the scaling behaviors of marginal power demand for growing rates of EV adoption will be critical for decision-makers to stay one step ahead of lagging realignments, anticipate them, and communicate optimal charging periods to consumers as well as intelligent infrastructure.

An important benefit of the methodology employed in this study is that it can be easily adapted to model additional use cases, charging profiles, emissions profiles, and additional pollutants. To prove the feasibility of such adaptations, SO₂ and NO_x grid emissions were simulated for the same charging profiles as CO₂ for the Suburban Errands trip in August and October. For these simulations, there were assumed to be no SO₂ emissions for the ICEV and HEV baselines. NO_x emissions for the ICEV and HEV baselines were calculated using a conversion factor of 0.000167 (gNO_x per mile/gCO₂ per mile), as informed by the MoVES model [26].

Figure 3-4 and Figure 3-5 depict pollutants that are greater per kilometer in EVs than ICEVs. SO₂ and NO_x are examples of pollutants emitted in the production of electrical energy at fossil power plants that are essentially absent from or significantly reduced (via catalytic conversion) in vehicular tailpipe emissions. While these additional pollutants should be acknowledged, it is

critical to understand the spatial confines of their dispersion. While tailpipe, mobile-source emissions are present anywhere motor vehicles travel, emissions from electricity generation are localized in smaller areas immediately surrounding power plant facilities. Given that power plants are typically located in more rural areas, the per-unit damages from pollutants emitted by electricity generation can be much less. However, there are environmental justice issues inherent in these trade-offs that need to be addressed and explored further.



Figure 3-4. SO₂ and NO_x emissions per kilometer (August)



Figure 3-5. SO2 and NOx emissions per kilometer (October)

4 Policy Implications

Because of the potential opportunity of vehicle electrification to help decarbonize the transportation sector and improve air quality, the technical findings of this research could have some significant policy implications. To optimize the potential benefits, much greater attention will be required to the incremental difference in EV emissions relative to baseline ICEVs and HEVs. As some of the findings suggest, the individual vehicle and fleetwide improvements may be much lower than expected by some studies as scale-up occurs. However, the findings also provide some suggested means of ensuring that environmental and social improvements can be realized, and at the scales needed. Because this research begins to quantify technical parameters related to both the *magnitude* and the *range* of possible emissions impacts as compared to multiple baselines (i.e., for vehicles, and the grid mix), the study's findings can be useful for education and awareness by all EV users. They also have clear implications on policy and public investment, including the urgent need for managed and coordinated charging, and greater attention to resource planning, in terms of generation resources, dispatch decision-making, infrastructure funding, and the long-run environmental benefits and impacts for EVs across a range of use cases and time horizons. Some of these specific issues and implications will be explored in more detail in a subsequent (Phase II study), but the following opportunities are clearly raised by this study:

- Educational and awareness programs to help consumers understand the emissions impacts of their charging behavior
 - Time of charging
 - Managed charging
 - Types of driving habits
 - Use cases for EV trips
 - Quantitative tools for comparing impacts to baselines and among different EV charging scenarios
- Quantitative measures for comparing and contrasting public support for charging infrastructure for residential vs. workplace
 - Grants, tax credits, supporting utility charging programs
 - Limited claims to manage scaling and growth
 - Need to identify single family vs multi-family dwellings
 - Incentivizing residential charging
 - Rate rebates/alternative rate structures, tax credits, vouchers, etc
- Facilitating information transfer between utility and consumer
 - (near) real-time communication from utility on emissions intensities to inform consumer decision making
- Supporting dynamic smart charging infrastructure and IoT
 - Optimizing charging for maximum environmental benefits at minimal cost, subject to user-defined constraints

- More investigation to workplace infrastructure utilization
 - Opportunity to utilize in off-peak
 - Incentivize use when emissions rates are more beneficial
- Electric grid and dispatch tools
 - Opportunities to increase visibility of utilities to information
 - Long term resource planning
 - Infrastructure investment decisions for future distribution/charging as well as future generation assets
- Expansion of HEV tax credits
 - HEVs consistently perform on-par with EVs in most scenarios, usually cheaper
- Importance of battery storage
 - Charge utility-scale batteries during periods of low emissions or with renewables to add to marginal mix as needed, reducing dependence on fossil marginal resources.
 - Important for grid resilience, managing increased demand for electrical power due to EV growth. Helps to mitigate “duck curve” issues.

5 Future Work & Limitations

5.1 Future Work

While this study has developed a novel and comprehensive methodology and explored an initial use case for comparison purposes, it has also raised important issues and additional dimensions that are suggestive of future work. These include the need to leverage this methodology to consider grid characteristics relative to energy, emissions, decision-making, and planning out to 2030, a closer look at additional vehicle categories, and the capability of the tool to be scaled and more broadly adapted for conducting similar analyses in other regions. Following are some specific suggestions for deepening, extending, and scaling the present work:

- Forecasting future grid compositions and marginal resources to predict and inform policy
 - Understanding how marginal resources will be deployed as growth in EV market share increases demand for electrical power
 - Pay particular attention to the interplay of deep deployment and popular charging times (such as overnight), as such insights will enable decision-makers to strategize to manage EV growth
- Incorporating MD/HD vehicles into simulations
 - The adaptable simulation methodology in this study can be used to understand MD/HD EV emissions and identify use cases that allow for optimized charging schedules
 - Attention to return-to-base MD delivery/service/fleet vehicles and the value proposition for public and private investments
- Geospatial distribution of pollutants and health impacts, equity considerations
 - Power plant vs. tailpipe
 - Comparative analyses between concentrating (point-source) emissions and dispersing (mobile-source) emissions; which is better from a public health perspective?
 - Environmental justice concerns, social impact of electric vehicles, costs, affordability, access to vehicles and chargers, etc.
- Exploration of additional EV charging considerations
 - A case study using EVALUATE to characterize fast charging devices in urban settings and estimation of emissions for Level 3 (vs. Level 2,1)
 - We can envision a means of aggregating the impacts of individual analyses, for instance by weighting vehicle classes and charging events based on their likelihood and current behaviors.

- Extension of the model to explore future projections of electric grid characteristics and response to EV growth with data from travel demand models
 - Convert historical electric grid basis to predictive tools for approximating grid dispatch characteristics and protocols into the near and intermediate future (e.g., 2025, 2030, 2040)
 - Develop guidance and toolkits to assist others in adapting EVALUATE for other regions
- Innovation
 - Technology transfer guidance for practitioners and decision-makers to maximize the effectiveness of upcoming public and private investments in fast-charging infrastructure
 - Consideration of battery charging as a grid resource and the potential for vehicle-to-grid (bidirectional) flows of energy.

5.2 Limitations

To investigate the true variability associated with CO₂ and other transportation-related vehicle emissions, this study has developed a simulation framework that explores multiple parameters concurrently. The goal has not been to determine with high precision a given case as much as it is to develop a broad comparison among major inputs and factors. In this way, we explore electric vehicles as compared to a baseline case (e.g., gasoline vehicles). We explore several driving cycles and charging profiles that represent typical approaches both for residential and workplace charging at various times of the day. And then, we develop various methods for estimating CO₂ and other vehicle emissions. As noted, studies that have addressed this previously have often utilized annualized averages to simplify the analysis. In our research review of other tools and dashboards (e.g., ChargePoint charge event portals, EPA locality CO₂ estimator via zip code), we confirmed that a very basic algorithm is utilized (such as a fixed or weighted average value for grid emissions, that does not consider time of day or seasons of the year). We acknowledge such traditional approaches provide a kind of first-order, initial estimation that can be useful to some audiences in some contexts. However, it is imperative to recognize and explain the limitations of accepted approaches, and the risk of relying too heavily on average emissions estimates, as they are highly subject to change in the future, and to variability during the present (including on multiple timescales, like throughout a given day, or season to season). In short, new tools and methodologies are needed that can estimate the impact of taking various assumptions for how the grid will meet marginal demands in the near, intermediate and long terms. This transition period from a few million EVs to 100 million EVs will take some time, and environmental impacts will need to be more fully understood. As EV adoption increases and the grid is expanded to meet new demands for electrification, such transition tools and methods can be increasingly valuable to researchers, planners, policymakers, and infrastructure decision-makers. As such, our present work provides much-needed additional insight and may be useful to inform 2nd order factors and more complex and integrated guidance. Going a step further by exploring limitations and pursuing additional rough orders of magnitude could have tremendous value for the transportation research

community. It would also facilitate a more direct and apples-apples comparison of EVs to other technologies there are substantial shortcomings as penetration rates grow.

We conclude with a brief recap. It is clear that at certain very low very modest levels of EV deployment, something like an average assessment of the weighted mix of resources may not be illogical or even inaccurate. It is beyond the scope of this study to determine exactly at what penetration rates things change, but it can be stated that at significant increases in EV charging, in particular at certain hours of the day and months and seasons of the year, the assumption of weighted mixes breaks down. Some preliminary findings from the use cases investigated in the present study reveal that conditions most at risk of yielding higher than desired CO₂ emissions rates include (a) afternoon charging at the workplace and (b) early evening charging at the residence. Conversely, it seems that residential overnight charging may, at present, be one of the lowest impact scenarios for EV charging.

The implications of these findings affect both the ***behavior of EV owners*** and the ***future planning of technical resources***. On the behavior side, it's clear that managing charging events throughout the 24 hours of the day should merit greater attention. It appears that residential charging may be environmentally preferred compared to workplace charging under certain conditions. This may be an important near-term way to mitigate the unintended effects of higher marginal emissions impacts. This, however, is a simplified observation, since it assumes adequate all-electric range and adequate access to residential EV charging. Neither of these assumptions is necessarily sound at higher penetration rates or given certain economic barriers and social inequities. Furthermore, charging management and behavior alone will likely be inadequate as EV shares grow to levels that push up against current resource capacities and are not yet envisioned fully and accommodated for utility resource plans in the 3-to-10-year horizon. Future study is anticipated to further inform decision-making around such scenarios, including the ability to convert the predominantly historical approach dispatch to a predictive forecasting approach where a 2030 scenario is developed that can better simulate future resources, both fossil, and non-fossil, and how they will be deployed to meet a growing load to support electric transportation.

While the use case results are of interest in their own right, it should be noted they are sensitive to the source data for the selected region and approaches taken to integrate electric charging behaviors. While the particular insights may not apply to other regions, it is important to note that the research team also intended to conduct a regional use case as a validation for the methodology. The methodology has been constructed and described in sufficient detail that it can be combined with other data sets and regional attributes for the purpose of adapting it as a decision support tools, beyond the particular region selected herein. Thus, the methodology is shown to be scalable and more broadly applied to other time horizons and regions, and leverage other data sets.

6 Conclusion

This research study focuses on a few specific vehicle types around light-duty vehicle uses in order to develop a comparative framework with a manageable technical scope. While additional use cases and extensions are suggested as areas of future work, the frameworks and simulation-based comparisons are extremely generalizable and extendable because of the organizational approach. A lot of attention to detail has been paid to the development of physics-based vehicle models, including consideration of architectures, powertrain, overall accessory loads, and sensitivity to drive cycle and external ambient temperatures. Similar attention to detail has been paid to developing practical and representative EV charging profiles, reasonable mapping of standard drive cycles to real-world trips and travel behavior, and high-fidelity analyses of existing grid dispatch methods based on real-world data.

A primary contribution of this effort is therefore the integration of each of the individual sub-systems and independent data sources, including hourly grid characteristics, toward a novel understanding of the complex impacts of vehicle electrification. In short, the team has successfully achieved its chief aim of laying the groundwork for a more complete understanding of these results at scale.

Regarding EV charging behavior, we have considered data from multiple concurrent sources which provides insight into when people are most likely to be charging their EVs today. A key finding is that overnight charging currently has the lowest absolute level of CO₂ emissions and a relatively low variance compared to other times of charging. This may not imply that an EV solution is categorically preferred on the grounds of net CO₂ emissions compared to a baseline HEV, although the research does permit such quantitative comparisons. And it does convey actionable information given the vast temporal optionality currently allowed for charging. Going forward, we can envision a means of aggregating the impacts of individual analyses, meaning that these events will be weighted based on their likelihood and current behaviors. We can furthermore consider behaviors will evolve as time goes by and as larger shares of EVs are realized.

However, within a transition period (e.g., 5 to 10 years) where EV growth and grid dynamics adapt iteratively, this study conducted novel simulations of the primary grid-vehicle scenarios which are reflective of current EV behavior and grid characteristics in recent years. The study's consultations with experts, literature review, and data analysis revealed that about $\frac{3}{4}$ of events occur at home, with 50% on a level two charger and 25% on a level one charger. This would suggest, for the near and intermediate term, that EVs will act as a kind of aggregated demand in the evening/overnight hours and that as a block (en masse as an emerging market segment), EVs are more likely to require marginal resources because they act together to force demand projections out of the expected regime. The good news is that, for the foreseeable future, these are, on balance, hours that are moderately lower in terms of marginal resource carbon intensity, since they can be met by intermediate resources (and not peaking resources). Whereas workplace charging is substantially less common, perhaps the marginal mix or the hourly estimation is reasonable for the effective CO₂ signatures.

As one thinks about the scale, and a situation where EV reach double-digit shares of the fleet, it's very likely that all the modes and locations of charging will eventually be subject to conditions where marginal assumptions prevail. How the transition period is defined and how the system boundaries between EV growth and grid resources are balanced are important, but open questions. Another essential unknown that will impact effective CO2 emissions from EVs are how predictable EV charging events become, with an emphasis on the high power, coincident peak events. More research into this question can help inform more accurate methods and models for simulating the environmental impacts of EVs. The present framework sets up an approach that will be valuable in estimating future impacts under such conditions. While additional focus and scope lie beyond this study, it is clear that a more complete understanding of popular EV charging profiles and EV driving behaviors will be essential inputs to better decision-making and resource planning. As EV use and charging habits become more predictable and well-known, the relevant data and insights can be critically valuable to utilities. For instance, foreknowledge of EV charging events (in time and space) will be needed at an aggregate level and could be beneficial to grid operators. The reason is that they can better plan and iterate their learning for those types of loads and events for which currently they lack visibility.

7 References

- [1] Ahmadi, P. Environmental impacts and behavioral drivers of deep decarbonization for transportation through electric vehicles. *Journal of Cleaner Production*, 2019. 225: 1209-1219.
- [2] Gallagher, C. L., & Holloway, T. Integrating air quality and public health benefits in US decarbonization strategies. *Frontiers in public health*, 2020. 8.
- [3] Thompson T, Webber M, Allen DT. Air quality impacts of using overnight electricity generation to charge plug-in hybrid electric vehicles for daytime use. *Environ Res Lett.*, 2009. 4:014002 10.1088/1748-9326/4/1/014002
- [4] Li, C., Cao, Y., Zhang, M., Wang, J., Liu, J., Shi, H., & Geng, Y. Hidden benefits of electric vehicles for addressing climate change. *Scientific reports*, 2015. 5: 9213.
- [5] Argonne National Laboratory, Light Duty Electric Drive Vehicles Monthly Sales Updates, August 2020. DOE/EERE/ Vehicle Technologies Office. <https://www.energy.gov/eere/vehicles/articles/fotw-1153-september-28-2020-cumulative-plug-vehicle-sales-united-states-reach>. Accessed 12/26/20.
- [6] EV Adoption Website. <https://evadoption.com/ev-models/>. Accessed 12/26/20.
- [7] Bloomberg New Energy Finance. 2019. Chart of EV forecast projections through 2030, drawing from a compilation of external sources that include: DOE/EIA, NREL, NAS, EEI, EPRI.
- [8] Hoshing, V., Vora, A., Saha, T., Jin, X., Shaver, G., Wasynczuk, O., ... & Varigonda, S. Comparison of economic viability of series and parallel PHEVs for medium-duty truck and transit bus applications. *Proceedings of the Institution of Mechanical Engineers, Part D: Journal of Automobile Engineering*, 2020. 0954407020919255.
- [9] Simmons, Richard A., Rodgers, Michael, from Drawdown Georgia, "Detailed Analysis of 20 High Impact Solutions: Transportation/Electric Vehicles" <https://cepl.gatech.edu/node/197> Accessed 12/26/20.
- [10] Brown, M., Beasley, B., Atalay, F., Cobb, K., Dwivedi, P., Hubbs, J., Iwaniec, D., Mani, S., Matisoff, D., Mohan, J., Oxman, M., Rochberg, D., Rodgers, M., Shepherd, M., Simmons, R.A., Taylor, L., Toktay, B., and Mullen, J., "Translating a Global Emissions Reduction Framework for Sub-National Climate Action: A Case Study from the State of Georgia," *Environmental Management* 67, no. 2 (2021): 205-227.
- [11] Yuksel, Tugce, and Jeremy J. Michalek. "Effects of regional temperature on electric vehicle efficiency, range, and emissions in the United States." *Environmental science & technology*, 2015. 49.6: 3974-3980.
- [12] Reichmuth, David. Are electric vehicles really better for the climate? Union of Concerned Scientists. February 11, 2020. <https://blog.ucsusa.org/dave-reichmuth/are-electric-vehicles-really-better-for-the-climate-yes-heres-why>. Accessed 12/26/20.

- [13] Simmons, Richard A. "A techno-economic investigation of advanced vehicle technologies and their impacts on fuel economy, emissions, and the future fleet." 2015.
- [14] Department of Energy, Energy Information Administration. Lawrence Livermore National Laboratory. 2023. <https://flowcharts.llnl.gov/sites/flowcharts/files/2024-10/energy-2023-united-states.pdf>. Accessed 11/22/2024.
- [15] U.S. EPA dynamometer drive schedules. <https://www.epa.gov/vehicle-and-fuel-emissions-testing/dynamometer-drive-schedules>. Accessed 12/28/20.
- [16] Zhao, Yingpin., "Distributional Impact Assessment of Transportation Policy Using Activity-Based Models with Path Retention." PhD Diss. Georgia Institute of Technology, 2020.
- [17] McGuckin, N. and Fucci, A. Summary of Travel Trends: 2017 National Household Travel Survey. 2018. Federal Highway Administration. https://nhts.ornl.gov/assets/2017_nhts_summary_travel_trends.pdf
- [18] Vejdani, S., Grijalva, S., & Simmons, R. Assessment of Grid-Scale Energy Storage Scenarios for the Southeast: Benefits, Costs and Implications. 2020. http://energy.gatech.edu/sites/default/files/images/epicenter_energystorage_finalreport_march2020.pdf. Accessed 12/27/20.
- [19] Simmons, R.A., "EPICenter- Overview and the Case for Regional Energy Partnerships," presented at the Future of Electric Transportation SE Policy Forum, Jan 2020. https://registration.conference.gatech.edu/DocumentStore/FET/Richard_Simmons.pdf. Accessed 12/27/20.
- [20] Sastry, K.V., Fuller, T.F., Grijalva, S., Taylor, D.G. and Leamy, M.J. Electric vehicle smart charging to maximize renewable energy usage in a single residence. 2021. In *IECON 2021–47th Annual Conference of the IEEE Industrial Electronics Society* (pp. 1-6). IEEE.
- [21] Sastry, K.V., Fuller, T.F., Grijalva, S., Taylor, D.G. and Leamy, M.J. Grid-Favorable, Consumer-Centric Smart Charging of Electric Vehicles in a Neighborhood. 2022 (pending/in review). IEEE Transactions on Smart Grid. IEEE
- [22] Georgia Power. Plug-In Electric Vehicle Rate. <https://www.georgiapower.com/residential/billing-and-rate-plans/pricing-and-rate-plans/plug-in-ev.html>. Accessed 7/17/2022.
- [23] Boyce, KC, Escalent. Personal conversation with PI of this study, May 2022, with reference to correspondence and an internal (non-public/client facing) report entitled, "EVForward, TM, Predicting the next generation of EV buyers just got real." April 2020.
- [24] Siler-Evans, K., Azevedo, I.L. and Morgan, M.G., 2012. Marginal emissions factors for the US electricity system. *Environmental science & technology*, 46(9), pp.4742-4748.
- [25] Hirschey, J., Simmons, R., Laclair, T., Gluesenkamp, K., Graham, S. "A Framework for Analyzing Widespread Grid Intervening Technologies: A Case Study of Heat Pump-Integrated Thermal Energy Storage Systems in Buildings." In: 2022 High Performance Buildings Conference. Purdue University. July 2022. Oak Ridge National Lab.(ORNL), Oak Ridge, TN (United States), 2022.

- [26] U.S. EPA (2020). MOVES3 Technical Guidance. Office of Transportation and Air Quality. 2020. <https://nepis.epa.gov/Exe/ZyPDF.cgi?Dockey=P1010LY2.pdf>. Accessed 7/17/2022.
- [27] Tayarani, H and Tal, G. “Exploring the Charging Behavior of Plug-in Electric Vehicles.” National Center for Sustainable Transportation, UC Davis. DOT Contract 69A3552348319. Pending 2025.

8 Data Summary

Products of Research

The following data were collected and used in the study. Relevant source data and methodologies are cited.

- Electric Vehicle energy consumption [9-15]
 - MATLAB/SIMULINK Codes [9, 13]
 - Vehicle parameters [13]
 - Powertrain characteristics [13]
 - Battery specs and control variables [13]
 - EPA dynamometer schedules [15]
- EV charging [9, 20-23]
- Electric Grid marginal emissions [24-25]
- CO₂ and other criteria pollutants [9, 13, 26]

Sub-system models involve datasets that are on file and disclosed in prior published work. The relevant data have been disclosed in part, represented graphically, and/or disclosed as tables within the body of this report, or its appendices. Interim datasets and the outputs of specific simulations are also available in the appendices on file and accessible electronically. The methodologies have been described and presented such that future sets of (source or interim) data can be utilized by existing or new models to generate new simulation outputs.

Data Format and Content

The data used and generated in this study has taken the form of Excel spreadsheet data, excel models, Excel-based lookup tables, MATLAB initialization codes, MATLAB Source codes, SIMULINK system, and sub-system models. Other public datasets have been acquired and conditioned for use in this study.

Data Access and Sharing

Some of the data and outputs from this study have been presented in the body of the report and in the appendices. Additional data and files are included in a dataset file and published at <https://doi.org/10.5281/zenodo.14347411>.

Reuse and Redistribution

Reuse and/or redistribution of the data and methods is encouraged by the general public. The authors request appropriate citation and attribution of the present study (or the source data, publications and prior work upon which it rests). When citing, please refer to the DOI identifiers for the written report and datasets of the present work as may be appropriate.

9 Appendices

9.1 Appendix A – EPA Five-Cycle Computations

Computation of EPA five-cycle city and highway fuel economy

Formulae for computing official city, highway and combined fuel economy estimates per the U.S. Environmental Protection Agency official rule [13].

$$CityFE = 0.905 * (1/(StartFC + RunningFC_{City})) \quad (A.1)$$

$$RunningFC_{City} = 0.82 * \left[\frac{0.89}{FE_{FTP_{75}}} + \frac{0.11}{FE_{US06_{City_{75}}}} \right] + 0.18 * \left[\frac{1}{FE_{FTP_{20}}} \right] + 0.14 * [FC_{AC}] \quad (A.2)$$

$$HighwayFE = 0.905 * (1/(StartFC + RunningFC_{Hwy})) \quad (A.3)$$

$$RunningFC_{Hwy} = 1.07 * \left[\frac{0.79}{FE_{US06_{Hwy_{75}}}} + \frac{0.21}{FE_{HWFET_{75}}} \right] + 0.05 * [AC] \quad (A.4)$$

Above, FE=Fuel Economy, FC=Fuel Consumption and EC=Energy Consumption. Subscripts represent either test cycles or HVAC modes where the number following an underscore indicates the test temperature in °F.

9.2 Appendix B – Level 1 Residential Charging Profiles

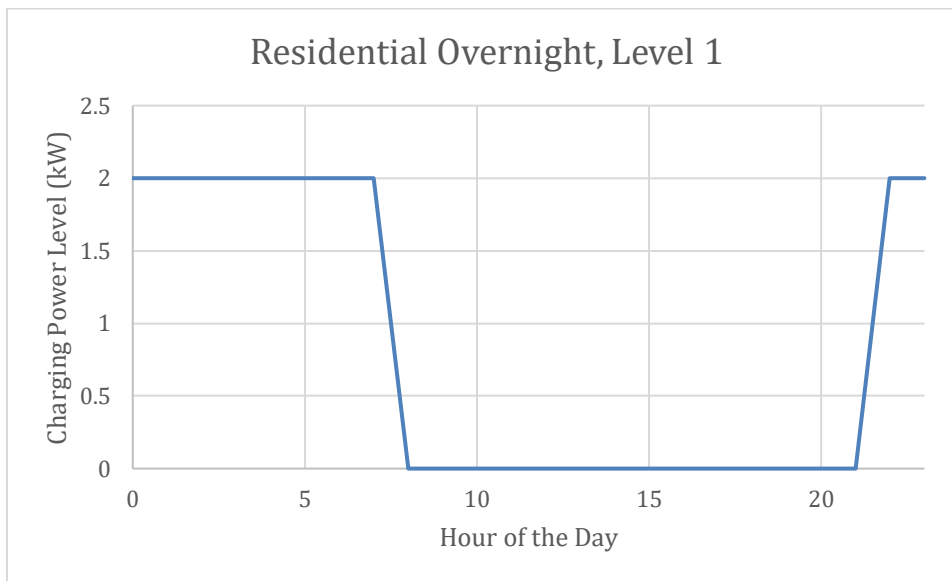

Figure 9-1. Level 1 Residential Overnight Charging Profile

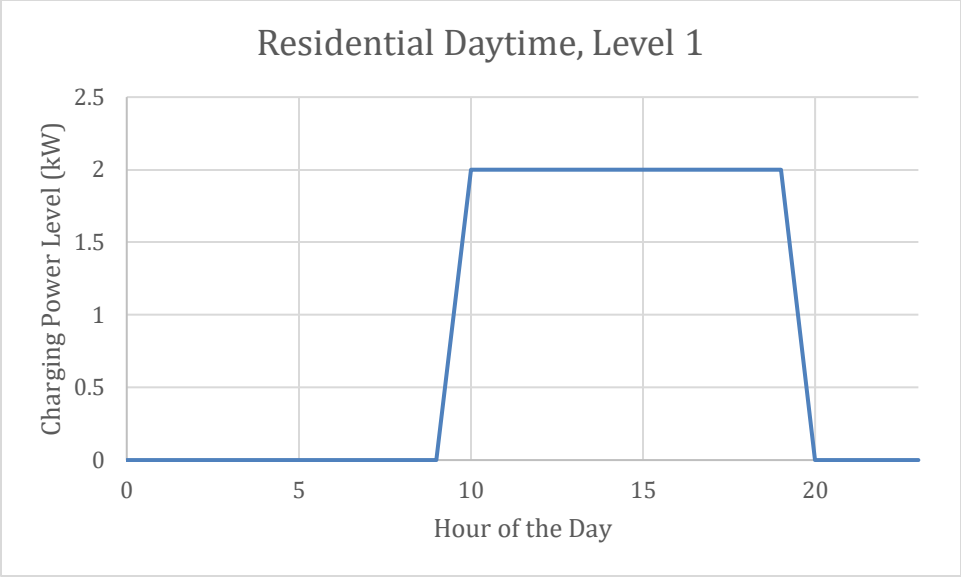

Figure 9-2. Level 1 Residential Daytime Charging Profile

9.3 Appendix C – MATLAB Initialization Code

```
%Initialization
clear;
close all;

load [insert charging profile file name here];
load [insert emissions profile file name here];

hours = 24; %no hours in day
E_init = 0.0; %Initial Energy Transferred
E_target = [insert target energy value]; %Target Value of Energy Consumption
in kWh
X_init = 0; %Initial Ontime State Variable
t_step = 1/60; %time step, set to 1/60 hour
eta_charging=0.88; %efficiency of Level 2 charger
eta_ref=0.83; %efficiency of Level 1 charger
```

9.4 Appendix D – Output Data

Table 9-1. Percent Improvement in kgCO₂/km over ICEV baseline (December outputs continued on the following page)

Commute (80.5km)	August				October			
	RO	RE	WM	WA	RO	RE	WM	WA
H	-34.81%	-32.59%	-23.03%	-28.84%	-30.53%	-35.05%	-25.61%	-32.47%
M	-31.57%	-31.57%	-31.57%	-31.57%	-33.84%	-33.84%	-33.84%	-33.84%
A	-34.08%	-34.08%	-34.08%	-34.08%	-34.08%	-34.08%	-34.08%	-34.08%
ICEV	0.00%	0.00%	0.00%	0.00%	0.00%	0.00%	0.00%	0.00%
HEV	-34.80%	-34.80%	-34.80%	-34.80%	-34.80%	-34.80%	-34.80%	-34.80%
HMM	-8.47%	-30.03%	-17.96%	-2.03%	-0.53%	-32.37%	-11.31%	-21.89%
HMRX	-9.57%	-46.20%	-7.10%	27.86%	-11.15%	-22.74%	1.23%	-34.35%
Commute (32.2km)								
H	-35.71%	-30.66%	-24.36%	-26.88%	-30.66%	-33.19%	-25.62%	-31.93%
M	-31.02%	-31.02%	-31.02%	-31.02%	-33.31%	-33.31%	-33.31%	-33.31%
A	-33.55%	-33.55%	-33.55%	-33.55%	-33.55%	-33.55%	-33.55%	-33.55%
ICEV	0.00%	0.00%	0.00%	0.00%	0.00%	0.00%	0.00%	0.00%
HEV	-34.80%	-34.80%	-34.80%	-34.80%	-34.80%	-34.80%	-34.80%	-34.80%
HMM	-23.78%	-13.53%	-34.07%	-5.67%	-20.77%	-32.39%	-1.61%	-15.18%
HMRX	-46.17%	-46.17%	-46.17%	30.98%	-46.30%	-22.12%	27.83%	-22.12%
Suburban Errands (48.3km)								
H	-54.61%	-51.16%	-46.58%	-48.50%	-51.08%	-52.94%	-47.52%	-52.00%
M	-51.36%	-51.36%	-51.36%	-51.36%	-52.97%	-52.97%	-52.97%	-52.97%
A	-53.14%	-53.14%	-53.14%	-53.14%	-53.14%	-53.14%	-53.14%	-53.14%
ICEV	0.00%	0.00%	0.00%	0.00%	0.00%	0.00%	0.00%	0.00%
HEV	-48.61%	-48.61%	-48.61%	-48.61%	-48.61%	-48.61%	-48.61%	-48.61%
HMM	-45.52%	-39.78%	-52.77%	-33.25%	-43.12%	-52.32%	-31.01%	-40.53%
HMRX	-60.29%	-62.04%	-60.29%	-7.64%	-60.44%	-45.08%	-11.00%	-45.63%

	December			
Commute (80.5km)	RO	RE	WM	WA
H	-34.20%	-38.76%	-40.58%	-35.25%
M	-38.76%	-38.76%	-38.76%	-38.76%
A	-34.08%	-34.08%	-34.08%	-34.08%
ICEV	0.00%	0.00%	0.00%	0.00%
HEV	-34.80%	-34.80%	-34.80%	-34.80%
HMM	-16.30%	-11.74%	-8.04%	-17.54%
HMRX	-48.23%	-39.80%	-4.01%	-45.76%
Commute (32.2km)				
H	-34.45%	-36.97%	-39.49%	-38.23%
M	-38.27%	-38.27%	-38.27%	-38.27%
A	-33.55%	-33.55%	-33.55%	-33.55%
ICEV	0.00%	0.00%	0.00%	0.00%
HEV	-34.80%	-34.80%	-34.80%	-34.80%
HMM	-19.52%	-32.59%	-9.69%	-20.78%
HMRX	-47.81%	-47.81%	-32.85%	-47.81%
Suburban Errands (48.3km)				
H	-53.75%	-55.61%	-57.36%	-56.30%
M	-56.47%	-56.47%	-56.47%	-56.47%
A	-53.14%	-53.14%	-53.14%	-53.14%
ICEV	0.00%	0.00%	0.00%	0.00%
HEV	-48.61%	-48.61%	-48.61%	-48.61%
HMM	-43.07%	-50.56%	-36.17%	-43.99%
HMRX	-63.20%	-62.80%	-51.23%	-63.20%

Table 9-2. kgCO₂/km (Level 2 charger) (December outputs continued on the following page)

	August					October			
Use Case	Charging Profiles					Charging Profiles			
Commute (80.5km)	RO	RE	WM	WA		RO	RE	WM	WA
H	0.107	0.111	0.126	0.117		0.114	0.107	0.122	0.111
M	0.112	0.112	0.112	0.112		0.109	0.109	0.109	0.109
A	0.108	0.108	0.108	0.108		0.108	0.108	0.108	0.108
ICEV	0.164	0.164	0.164	0.164		0.164	0.164	0.164	0.164
HEV	0.107	0.107	0.107	0.107		0.107	0.107	0.107	0.107
HMM	0.150	0.115	0.135	0.161		0.163	0.111	0.146	0.128
HMRX	0.149	0.088	0.153	0.210		0.146	0.127	0.166	0.108
Commute (32.2km)									
H	0.106	0.114	0.124	0.120		0.114	0.110	0.122	0.112
M	0.113	0.113	0.113	0.113		0.110	0.110	0.110	0.110
A	0.109	0.109	0.109	0.109		0.109	0.109	0.109	0.109
ICEV	0.164	0.164	0.164	0.164		0.164	0.164	0.164	0.164
HEV	0.107	0.107	0.107	0.107		0.107	0.107	0.107	0.107
HMM	0.125	0.142	0.108	0.155		0.130	0.111	0.162	0.139
HMRX	0.088	0.088	0.088	0.215		0.088	0.128	0.210	0.128
Suburban Errands (48.3km)									
H	0.087	0.094	0.103	0.099		0.094	0.091	0.101	0.092
M	0.094	0.094	0.094	0.094		0.091	0.091	0.091	0.091
A	0.090	0.090	0.090	0.090		0.090	0.090	0.090	0.090
ICEV	0.193	0.193	0.193	0.193		0.193	0.193	0.193	0.193
HEV	0.099	0.099	0.099	0.099		0.099	0.099	0.099	0.099
HMM	0.105	0.116	0.091	0.129		0.110	0.092	0.133	0.115
HMRX	0.076	0.073	0.076	0.178		0.076	0.106	0.171	0.105

	December			
Use Case	Charging Profiles			
Commute (80.5km)	RO	RE	WM	WA
H	0.108	0.101	0.098	0.106
M	0.101	0.101	0.101	0.101
A	0.108	0.108	0.108	0.108
ICEV	0.164	0.164	0.164	0.164
HEV	0.107	0.107	0.107	0.107
HMM	0.137	0.145	0.151	0.135
HMRX	0.085	0.099	0.158	0.089
Commute (32.2km)				
H	0.108	0.104	0.099	0.101
M	0.101	0.101	0.101	0.101
A	0.109	0.109	0.109	0.109
ICEV	0.164	0.164	0.164	0.164
HEV	0.107	0.107	0.107	0.107
HMM	0.132	0.111	0.148	0.130
HMRX	0.086	0.086	0.110	0.086
Suburban Errands (48.3km)				
H	0.089	0.085	0.082	0.084
M	0.084	0.084	0.084	0.084
A	0.090	0.090	0.090	0.090
ICEV	0.193	0.193	0.193	0.193
HEV	0.099	0.099	0.099	0.099
HMM	0.110	0.095	0.123	0.108
HMRX	0.071	0.072	0.094	0.071

Table 9-3. kgCO₂/km (Level 1 charger, residential charging)

	August		October		December	
Use Case	Charging Profiles		Charging Profiles		Charging Profiles	
Commute (80.5km)	ResON - Lvl1	ResDT - Lvl1	ResON - Lvl1	ResDT - Lvl1	ResON - Lvl1	ResDT - Lvl1
H	0.126	0.127	0.129	0.124	0.121	0.113
M	0.122	0.122	0.118	0.118	0.109	0.109
A	0.117	0.117	0.117	0.117	0.117	0.117
ICEV	0.164	0.164	0.164	0.164	0.164	0.164
HEV	0.107	0.107	0.107	0.107	0.107	0.107
HMM	0.151	0.172	0.149	0.154	0.128	0.134
HMRX	0.153	0.192	0.155	0.143	0.092	0.108
	August		October		December	
Use Case	Charging Profiles		Charging Profiles		Charging Profiles	
Commute (32.2km)	ResON - Lvl1	ResDT - Lvl1	ResON - Lvl1	ResDT - Lvl1	ResON - Lvl1	ResDT - Lvl1
H	0.121	0.134	0.126	0.127	0.121	0.106
M	0.122	0.122	0.118	0.118	0.109	0.109
A	0.117	0.117	0.117	0.117	0.117	0.117
ICEV	0.164	0.164	0.164	0.164	0.164	0.164
HEV	0.107	0.107	0.107	0.107	0.107	0.107
HMM	0.162	0.156	0.156	0.144	0.146	0.116
HMRX	0.153	0.166	0.132	0.138	0.092	0.092
	August		October		December	
Use Case	Charging Profiles		Charging Profiles		Charging Profiles	
Commute (48.3km)	ResON - Lvl1	ResDT - Lvl1	ResON - Lvl1	ResDT - Lvl1	ResON - Lvl1	ResDT - Lvl1
H	0.125	0.131	0.130	0.125	0.125	0.110
M	0.122	0.122	0.118	0.118	0.109	0.109
A	0.117	0.117	0.117	0.117	0.117	0.117
ICEV	0.193	0.193	0.193	0.193	0.193	0.193
HEV	0.099	0.099	0.099	0.099	0.099	0.099
HMM	0.162	0.162	0.156	0.144	0.139	0.129
HMRX	0.173	0.182	0.151	0.129	0.092	0.180

Table 9-4. gSO₂/km for Suburban Errands Trip

SO ₂ (g/km)									
	August					October			
	Charging Profiles					Charging Profiles			
	RO	RE	WM	WA		RO	RE	WM	WA
H	0.126	0.095	0.100	0.102		0.179	0.152	0.134	0.116
M	0.076	0.076	0.076	0.076		0.085	0.085	0.085	0.085
A	0.080	0.080	0.080	0.080		0.080	0.080	0.080	0.080
ICEV	0.000	0.000	0.000	0.000		0.000	0.000	0.000	0.000
HEV	0.000	0.000	0.000	0.000		0.000	0.000	0.000	0.000
HMM	0.089	0.093	0.040	0.123		0.120	0.000	0.167	0.067
HMRX	0.011	0.002	0.011	0.308		0.012	0.002	0.304	0.002

Table 9-5. gNO_x/km for Suburban Errands Trip

Nox (g/km)									
	August					October			
	RO	RE	WM	WA		RO	RE	WM	WA
H	0.163	0.149	0.147	0.149		0.324	0.300	0.319	0.333
M	0.130	0.130	0.130	0.130		0.208	0.208	0.208	0.208
A	0.168	0.168	0.168	0.168		0.168	0.168	0.168	0.168
ICEV	0.032	0.032	0.032	0.032		0.032	0.032	0.032	0.032
HEV	0.017	0.017	0.017	0.017		0.017	0.017	0.017	0.017
HMM	0.121	0.134	0.079	0.174		0.226	0.259	0.397	0.290
HMRX	0.031	0.024	0.030	0.258		0.041	0.150	0.593	0.303