

UC Berkeley

Research Reports

Title

A Conceptual Simulation Framework For Mobile Radio Communications: A Flexilevel Approach

Permalink

<https://escholarship.org/uc/item/9nj0n012>

Author

Silvester, John A.

Publication Date

1997

This paper has been mechanically scanned. Some errors may have been inadvertently introduced.

CALIFORNIA PATH PROGRAM
INSTITUTE OF TRANSPORTATION STUDIES
UNIVERSITY OF CALIFORNIA, BERKELEY

A Conceptual Simulation Framework for Mobile Radio Communications: A Flexilevel Approach

John A. Silvester

University of Southern California

**California PATH Research Report
UCB-ITS-PRR-97-40**

This work was performed as part of the California PATH Program of the University of California, in cooperation with the State of California Business, Transportation, and Housing Agency, Department of Transportation; and the United States Department of Transportation, Federal Highway Administration.

The contents of this report reflect the views of the authors who are responsible for the facts and the accuracy of the data presented herein. The contents do not necessarily reflect the official views or policies of the State of California. This report does not constitute a standard, specification, or regulation.

Report for MOU 14I

November 1997

ISSN 1055-1425

**A Conceptual Simulation Framework
for Mobile Radio Communications:
A Flexilevel Approach**

John A. Silvester

A Conceptual Simulation Framework for Mobile Radio Communications: A Flexilevel Approach

1. Introduction

Mobile radio communications systems are attracting more and more attention since they provide a means for users on the move to exchange information with other stationary or mobile stations. The capability of communication on the move can support many services and create lots of applications. For example, in the future Intelligent Vehicles Highway Systems (NHS), mobile communication technologies have enabled two important subsystems, namely Advanced Traffic Management and Information Systems (ATMIS) and Automatic Vehicular Control Systems (AVCS).

In ATMIS, vehicles send status information such as velocity to traffic management centers via roadside base stations so that the vehicular traffic on highways can be better managed. In addition, people in vehicles can request information from intelligent databases through roadside base stations about road traffic conditions and value-added services such as yellow pages. The two-way communication between users/vehicles and roadside base stations is an crucial component in the overall communications systems in ATMIS, since roadside base stations and traffic management centers can be connected by wire-based communication links (such as cable and fiber optical links) which usually have higher quality and larger bandwidth than radio links.

As for AVCS, mobile communication can be used for vehicles to exchange status information, such as velocity, acceleration and driving intentions, with neighboring vehicles so that driving safety and traffic density can be increased on highways. Compared with **ATMIS**, the communication range of a vehicle in AVCS is smaller; vehicles only need to know the conditions of their neighbors.

The purpose of this research is to develop a modeling/simulation framework for the radio communications networks in ATMIS. The framework is expected to be able to help system designers understand the key parameters in designing the radio communications system by performing analyses and simulations. After the key system parameters are identified, the system performance then can be trade-offed against costs such as RF bandwidth and system complexity. Though most of the modeling concepts can be carried over to AVCS, our discussion will be focused on ATMIS.

To our knowledge, there have been some simulation models developed for evaluating the performance of mobile radio networks. For example, MONET3 [9] is a simulation environment for vehicle-to-vehicle communications in RTI/IVHS (Road Transport Informatics/Intelligent Vehicle Highway Systems). In MONET3, realistic vehicular traffic modeling has been considered. But the physical layer parameters such as channel models and capture criterion are tightly merged into the simulation kernel. This implies that all packet receptions have to be evaluated at a given level of detail, which is not flexible. There are some canned simulation tools (e.g.,OPNET) which emphasize primarily on user interface but simplify the

physical layer model in a way that the assumptions of detailed simulation are hidden from the users, or they may not be adjusted easily by the users if they are not hidden completely.

Knowing the deficiencies of existing work, our objective is to develop a flexible framework for modeling and simulation of the radio communications networks between vehicles and base stations, taking into account the fact that vehicles are mobile, channels are fading and user data traffic is random. Toward that end, we have first developed a conceptual framework for modeling/simulation of mobile radio networks. Then a baseline model is implemented and a preliminary study on the requirement of the level of detail to be incorporated into the modeling environment is conducted. In particular, we investigate the effect of different mobile radio channels on both the system and user performance.

The rest of the report is organized as follows. Section 2 describes the framework developed for the modeling/simulation of radio networks for **ATMIS**. The component models are introduced and their interfaces are discussed. In Section **3**, a baseline model that is used to study the effect of channel models on system and user performance is introduced. The simulation results are reported and discussed. Section **4** gives some conclusions.

2. The Framework for Mobile Radio Communications

In **this** section, we will introduce the system level view of the simulation framework. The parameters and levels of detail of the component models will be

described. We will discuss how to achieve uniform interfaces between component models characterized at different levels of detail.

System Level Model

From the viewpoint of the system level, there are two types of entities in the mobile radio communications network: vehicles and base stations. They interact with one another by a shared radio channel. To model the system, the shared radio channel is abstracted by a simulation kernel as shown in Fig. 1. The kernel serves as an interface between **all** the communications entities (say, N vehicles and M base stations) so that we can model the whole system at different levels of detail. More detailed models give better accuracy at the cost of more extensive computation time. Simple models can produce results in shorter time but the accuracy may not be satisfactory. Thus, there exists a need to investigate the trade-off between accuracy and the level of detail incorporated into the system level model.

The simulation kernel maintains the topology of the network, i.e., the positions and velocities **of all** communication entities, including vehicles and base stations. To reduce the volume of messages flowing between vehicles and kernel during simulation **run**, the movement of vehicles is handled by the movement module inside the kernel (and therefore outside the vehicle model). This simplification assumes that the movement of vehicles are independent of the packet reception capability of the vehicle models. If this assumption is unacceptable, the mobility of individual vehicle has to be modeled inside the vehicle model; the dynamic position of vehicles, then, have to be updated to the kernel by messages

passing between vehicle models and the kernel. This case can happen for AVCS service where radio communication is used for automatic vehicular control, in which case vehicles may have to slow down if the communication between the proceeding vehicles is lost for a significant period of time for safety reason.

Since the kernel has a global view of the whole network, it can choose a proper channel model for each of the active transmitter and receiver pair. Channel selection module will be described in more details later on.

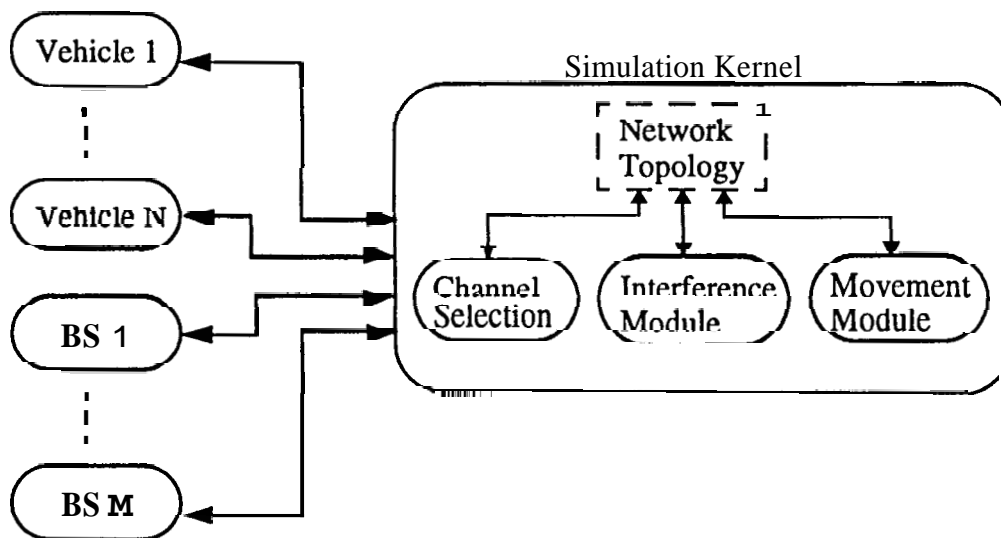

Fig. 1. The system level view of the radio simulation framework for ATMIS.

2.1 Vehicle Model

In the vehicle model, the major component models are user data traffic model, channel access protocol, transceiver model, and external interface which are shown in Fig. 2. Each of the component model can be described at different levels of detail.

We will describe the function of each component model as follows.

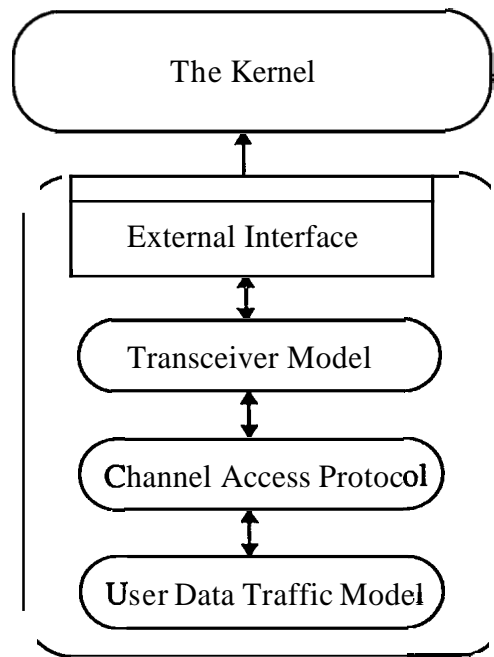

Fig. 2. The component models in a vehicle model.

External Interface

A vehicle interacts with other communication entities through a common external interface, which handles messages to and from the kernel. After receiving a message regarding a packet to be transmitted from the transceiver model, the external interface will tag the message with the identification of the vehicle and send it to the kernel. Upon receiving the message, the kernel will decide which communication entities are affected by this transmission (by consulting the topology module and channel selection module) and deliver the message to all entities that are within the receiving range or interfering range of the transmitter. A

message received by a vehicle carries information about a transmission that could origin from any communication entity which is within the receiving range or interfering range of the transmitting vehicle.

Transceiver Model

To transmit a packet coming from the channel access protocol within the vehicle model, the transceiver model send to the external interface a message that contains not only the packet itself but also the carrier frequency, the transmitted power, the antenna height, the duration of transmission, and other relevant information about this transmission, depending the desired level of detail.

Upon receiving a message from the external interface, the transceiver model needs to determine if the packet satisfies the criterion of successful reception. This criterion can be as simple as the average SIR (signal power to interference ratio) per packet or can be more complex, such as SIR per bit with correlated bit error probability. It is also possible to consider more complicated criterion than SIR, if lower level of detail is of interest. Note that it is up to users to trade-off the merits between the accuracy obtained by more detailed models with faster run time obtained by simple approximate models.

Channel Access Protocol

This module accepts packets coming from user data traffic model and handles the timing of packet transmission and retransmission. Its major function is to avoid packet collision due to simultaneous transmissions of communication entities. Various channel access protocols for packet radio networks can be plugged into this

model. Their performance can be evaluated by simulation.

User Data Traffic Model

In the user data traffic model, there are at least two levels of detail can be considered. The first one is a simple model in which packets **are** generated by a memoryless source with the inter-packet generation time characterized by a random variable with a given distribution. In this simple model, reliable end-to-end packet delivery is not of concern. Alternatively the user data traffic model can be described by a finite-state machine with state-dependent packet generation mechanism. This level of detail allows us to consider the possibility of modeling queued packets and blocking due to waiting for acknowledgment.

2.2 Simulation Kernel

The simulation kernel consists of four major parts, namely the network topology, the interference module, the channel selection module, and the movement module, **as** shown in Fig. 1. Among these four parts, the network topology is the state of the network, which stores the position and the velocity of every communication entity in the system. The information stored in the network topology will help the kernel determine the channel models, the interference strength, and the movement of mobile vehicles. These parts will be detailed in the following.

One of the major function of the simulation kernel is to determine which communication entities will be affected by a given transmission. Strictly speaking,

every transmission from an communication entity will influence the reception of all other communication entities more or less. To precisely simulate at this level of detail, we need to keep track of the effect on all other communication entities for every transmission from communication entities. This is apparently a formidable task which will cost us tremendous simulation run time before any result can be obtained.

Fortunately, due to the fast attenuation of signal strength with increasing propagation distance in a radio channel, transmission from a distant entity tends to have negligible effect on a far-away entity. Therefore, it make sense to approximate the influence of distant transmissions by a noise effect. *So* the question now is how far is enough for a "good approximation." The answer clearly depends on what do we mean by a "good approximation." In other words, there is a trade-off between accuracy and simplicity in making an approximation.

Interference Module

The function of the interference module is to simplify the effect of "distant transmitters" by a single interference source. By "distant transmitters" we mean the communication entities that will produce interference power less than a given threshold specified by the user who is performing the simulation. For example, the vehicles at the cells other than the one we are considering can be approximated by a single interference source with the strength described by certain statistics which can be statically specified before simulation or dynamically updated as simulation proceeds. The higher the threshold is, the faster the simulation will run at the cost

of more inaccurate results. This module is considered **as** a very important module in the kernel in that good approximation will result in fast simulation and yet sufficiently accurate results.

Propagation and Channel Models

Many researches have been done on measurements and modeling of mobile radio channels. Channel characteristics modeled at different level of detail are observed. One of the major efforts in channel measurement and modeling is to characterize the propagation path **loss as** a function **of** propagation distance. Measurements results show that the path loss exponents are different for different propagation ranges. For the propagation distance shorter than the first Fresnel clearance (**also** known **as** the breakpoint), which depends on the heights of the transmitting and receiving antennas, the path loss exponent is between 1 and 2. Beyond the breakpoint, the path loss exponent ranges from **3** to **6**, depending the geographic environment.

Another feature of mobile radio channels is the fading effect, which occurs due to the multipath propagation effect. The signal power may go down up to several tens **of** dB with multipath fading. The statistics of the envelop of a signal that suffers multipath fading are found to be well characterized by Rayleigh or Rician distributions depending on whether there exists a line-of-sight (**LOS**) ray between the transmitter and receiver. Besides the statistics of fading envelops, the correlation of temporal fading classifies fading channels into slow fading or fast fading channels. The temporal fading statistics have **an** impact on the choice of

error control schemes. Forward error correction (FEC) codes are known to be able to improve the quality of transmission in fast fading channels, whereas interleaving/FEC is required for slow fading channels.

Shadowing effect, which usually occurs when the **LOS** ray is blocked by obstacles such as big trucks on highways, will cause signal power to fade slowly from its mean power determined by the path loss. The statistics of the shadowing effect is found to be well characterized by lognormal random variables with parameters to be determined by measurements.

Channel Selection Module

The kernel needs to select a channel model and determine the model parameters for every receiver that will be affected by a given transmission. To be precise, the chosen channel model should be dependent on the operating frequency, the characteristics (e.g., heights, polarization, patterns, etc.) of the antennae involved, the distance between the transmitter and receiver, the local geographic environment (which will affect the fading statistics), and so on. Several levels of detail could be considered for the channel selection module, depending on the objective of a simulation run. Simple selection criterion could consider only the distance between the transmitter and the receiver, whereas more detailed selection criterion could take into account more factors which are dependent on the dynamic state of the network topology.

For example, if the objective of a particular simulation run is to see the impact of shadowing effect on system performance, the kernel can use a channel model that

statistically characterize the shadowing effect. Alternatively, the kernel can determine if the **LOS** ray between a given transmitter/receiver pair **is** blocked by looking at the dynamic topology of the network as simulation proceeds. Though the complexity is increased in the latter case, most realistic scenarios are considered, which shows the trade-off between the accuracy and faster simulation run time, again.

Dccoupling between the Detail of Transceiver Model and Kernel

Having discussed that the kernel is responsible for channel selection and interference modeling, we will emphasize that the kernel is not involved in determining if a packet is successfully received or not. It is up to the receiver to make a decision according to its transceiver model and the channel models given by the kernel. In other words, the kernel will deliver relevant transmissions plus the associated channel models (and their parameters) to receivers. In this way, kernel is independent of the level **of** detail being considered at transceivers. Kernel only serves **as** a packet filter and interference modeler, which effectively prevent the kernel from being **a** bottleneck of simulations.

Another advantage that kernel does not arbitrate if receivers capture packets is that we may be interested in the scenario where different receivers are implemented with different level of detail so that we know how accurate simple models are compared to complicated receiver models. Furthermore, we may want a more realistic receiver model at base stations while simple receiver models at vehicles to speed up simulation. Or we may want to simulate a particular cell in

detail and simulate other cells approximately.

Though the kernel is decoupled from deciding if a packet is successfully received by a receiver, it is responsible to identify and inform all relevant receivers for every transmission. How can this be done efficiently? One way is to compute the transmission radius based on the transmission power and then search for all receivers within this radius in the kernel by consulting the network topology. Another way, which is more efficient, is to cache the names of the communication entities that are within this radius for each transmitter. This information is updated periodically to faithfully reflect topology change. The network topology is maintained by the movement module, which will simulate the vehicular traffic flow and update the network topology periodically.

3. Baseline Model

This section shows a baseline simulation model that we have developed to investigate how different models of mobile radio channels affect the system and user performance. The channel access protocol for vehicles to communicate with base stations is slotted ALOHA. Though this protocol has been analyzed in the literature [2] [3] [4] [5], here we focus on the effects of channel parameters and user location on system and user performance.

In mobile radio channels, transmission signals suffer propagation loss, shadowing, and multipath fading. Hence signals transmitted by different terminals arrive at the base station with different power levels. This gives the strongest signal

a chance to be successfully received by the base station in the presence of other simultaneous transmission. This phenomenon, called the capture effect [1], can improve network performance. Typical mobile radio channels such as Rayleigh, Rician, Rayleigh with lognormal shadowing, and Rician with lognormal shadowing are considered in this simulation model.

Section 3.1 introduces the 4 channel models to be studied and the capture criterion. Section 3.2 describes the network model, including models for user data traffic and other-cell interference. The simulation experiments and results are discussed in Section 3.3.

3.1 Channel Models and Capture Criterion

A. Characteristics of the Mobile Radio Channel

Signal propagation in a mobile radio channel is characterized by propagation power loss, shadowing, and multipath fading. When the direct path component (main LOS ray) exists, the variation of signal strength with distance was found to show distinct near and far regions separated by a break point. The power loss factor is found to be less than 2 before the break point, while it is greater than 2 after the break point [6]. In the present study, the power loss factor is chosen to be 2 before the break point and 3 after the break point. So the area mean power is related to the transmission power by

$$P_{\text{area}} = r^{-\alpha} \cdot P_{\text{transmit}}, \text{ where } \alpha = 2 \text{ or } 3.$$

With lognormal shadowing, the local mean power has a probability density function

given by

$$f(p) = \frac{1}{\sqrt{2\pi}\sigma_s p} \exp\left[-\frac{1}{2}\left(\frac{\ln(p) - \ln(P_{\text{area}})}{\sigma_s}\right)^2\right],$$

where σ_s is the standard deviation of the logarithm of the local mean power. The value of σ_s depends on the severity of shadowing. Here σ_s is chosen to be 1 neper (or **4.34** decibels).

With the main **LOS** ray, multipath fading is usually modeled as Rician fading with the Rician factor \mathbf{K} defined as the ratio of the power of the **LOS** component to the scattered power. In the microcellular environment, \mathbf{K} is measured to be 7 dB to 12 dB [7]. In our study, \mathbf{K} is chosen to be 10 dB. Note that the channel becomes Rayleigh when $\mathbf{K} = 0$.

B. The 4 Channel Models

Four channel models are considered, namely, Rayleigh ($\mathbf{K}=0, \sigma_s=0$), Rician ($\mathbf{K}=10, \sigma_s=0$), Rayleigh with lognormal shadowing ($\mathbf{K}=0, \sigma_s=1$), and Rician with lognormal shadowing ($\mathbf{K}=10, \sigma_s=1$). Though some of them are less likely to exist in microcellular environment, the performance of these channels can help us understand how \mathbf{K} and σ_s impact system performance.

C. The Capture Criterion

It is assumed that the packet with the strongest signal can capture the receiver at the base station if its power is at least \mathbf{R} times greater than the sum of all other

transmission, including other-cell interference. R is called the capture threshold whose value depends on the modulation and coding schemes. Typical values of R range from 3 dB to 20 dB [8]. In the present study, R is chosen to be 4 (or 6 dB).

3.2 Network Model

A. User Data Traffic Model

Assume there are M independent single-buffered users in a cell, i.e., u_1, u_2, \dots, u_M . The distance between u_i and base station is d_i for $i = 1, 2, \dots, M$. A user is either in the idle state or in the backlogged state. When in the idle state, a packet will be generated and transmitted in the next slot with probability p_0 . If the transmission is successful, the terminal will receive a positive feedback right after the transmission and remain in the idle state. Whereas if the transmission is not successful, it will enter the backlogged state and retransmit the packet with probability q in the following slots until it succeeds. We can consider (as an approximation) that terminal i will transmit with probability b_i (the active probability), including new transmissions and retransmissions. The b_i 's can be measured by simulation and will be used to calculate the other-cell interference.

B. Other-cell Interference

To reduce the complexity of the simulation model, the effect of transmissions from users in the other cells is not simulated exactly. Instead, the interference power from other cells is approximated as Gaussian with mean m_I and variance v_I given by

$$m_I = \sum_{\text{all interferers } k} b_k (\text{area mean power of interferer } k)$$

and

$$v, = \sum_{\text{all interferers } k} b_k [(\text{area mean power of interferer } k) - m_I]^2.$$

C. Performance Measure

After a simulation run, the throughput and average packet delay are collected for each terminal. This gives the user performance. The network throughput can be obtained by summing the throughputs of all users in a cell. The network average delay can be obtained by

$$D = \sum_{i=1}^M D_i \frac{S_i}{S},$$

where S_i , S and D_i are the throughput of user i , the total network throughput, and the delay of user i , respectively.

3.3 Simulation Experiments and Results

The simulation experiments are based on the network topology shown in Fig. 3. u_1, u_2, \dots, u_{50} are in the cell of interest, and I_1, I_2, \dots, I_{50} are interferers in other cells. The cell radius is normalized to 1. It is assumed that the **break** point is on the cell boundary.

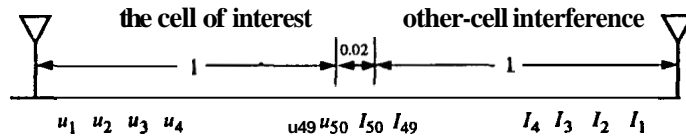

Fig. 3. The network topology of the baseline model.

With equal spacing between consecutive users, we have $d_1 = 1/50$ and $d_i = i^* d_1$. Define d_i' to be the distance between I_i and the base station of interest. d_i' is given by $d_i' = 2 + d_1 - d_i$. We assume that u_i and I_i have the same active probability b_i . To get estimates of m_I and v_I , they are initially set to 0. After the first simulation run, the active probabilities of u_1, u_2, \dots, u_{50} are used to compute m_I and v_I . Then we execute 10 independent runs to collect performance statistics of each user and compute the network throughput and average delay. Ninety-five percent confidence intervals are provided as long as they will not clutter the plot.

Fig. 4 and 5 show the throughput and delay of each user for a lightly loaded system ($p_0 = 0.005$, $q = 0.05$). It is observed that the 4 channels have similar performance. Fig.6 and 7 show the user performance for a system with higher load ($p_0 = 0.006$, $q = 0.12$). It is found that channels (Rayleigh or Rician) with shadowing have higher network throughput than channels without shadowing.

Fig. 8, 10 and 12 compare network throughput of the 4 channels as a function of p_0 and q . One interesting phenomenon was observed. In Fig. 10 and 12, throughput increases as we increase load until the combined load of near and far

users saturate the channel and throughput drops. As we further increase the load, the far users are driven into the backlog state but the near users continue to succeed on their first attempt, resulting in increased throughput. As we increase load further we could expect a drop in throughput again when the near users saturate.

Fig. 9, 11 and 13 compare the throughput-delay performance of the 4 channels with various retransmission probabilities (i.e., $q = 0.04$, **0.08** and 0.12). It is observed that Rician has slightly better performance than Rayleigh when load is light. When network is heavily loaded, Rayleigh has better performance than Rician. Similarly, Rician with shadowing has better performance than Rayleigh with shadowing when load is light; Rayleigh with shadowing performs better than Rician with shadowing when load is heavy. Also, it is observed that channels with shadowing have better performance when load is heavy, whereas channels without shadowing have slightly better performance when load is light. From Fig. 9, 11 and 13, we can see as expected that for all channels larger q has lower delay when load is light, whereas larger q has smaller capacity when load is heavy.

The user performance in a Rician channel for **3** different packet arrival probabilities ($p_0 = 0.004$, **0.007** and **0.012**) are shown in Fig. 14 and 15. We can see, in Fig. 14, that the **3** different values give approximately the same network throughput (**0.2**) but completely different spatial distribution. In particular, with $p_0 = 0.004$, all users have similar throughput. As p_0 increases to 0.007 , near and far users have significantly unbalanced throughput. When $p_0 = 0.016$, almost all the network throughput is attributed to near users. In Fig. 15, it can be seen that the

delay of far users increases as p_0 increases. Though the delay of far users is large, their throughputs are small. Therefore network average delay does not necessarily increase as p_0 increases. In Fig. 13, for example, network delay under Rician channels starts to decrease when p_0 exceeds some value. Of course, most successful packets are transmitted by near users.

Based on simulation results, we have the following conclusions. First, location relative to base station does play a role in user performance for all the channel models considered. This factor will become more significant when the communication system is overloaded. When the channel is overloaded, distant user will experience a very bad communication link to base station because close-in users have saturated the channel.

Secondly, channel parameters, such as the severity of multipath fading and shadowing, do not significantly impact network performance such as average throughput and mean packet delay when the channel load is light. But when the channel is overloaded, fading and shadowing will help improve network performance since the difference of the signal strength of simultaneous transmissions will be enhanced, which actually increasing the chance of receiver capture.

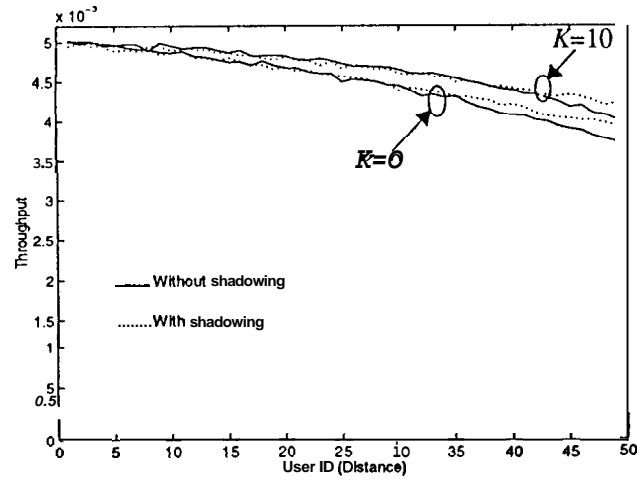

Fig. 4. Throughput of each user under 4 channel models. $p_0 = 0.005$, $q = 0.05$, and $\sigma_s = 1$ for shadowing.

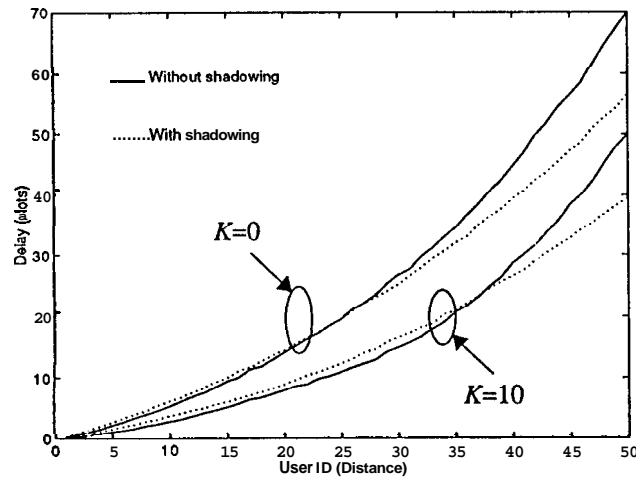

Fig. 5. Delay of each user under 4 channel models. $p_0 = 0.005$, $q = 0.05$, and $\sigma_s = 1$ for shadowing.

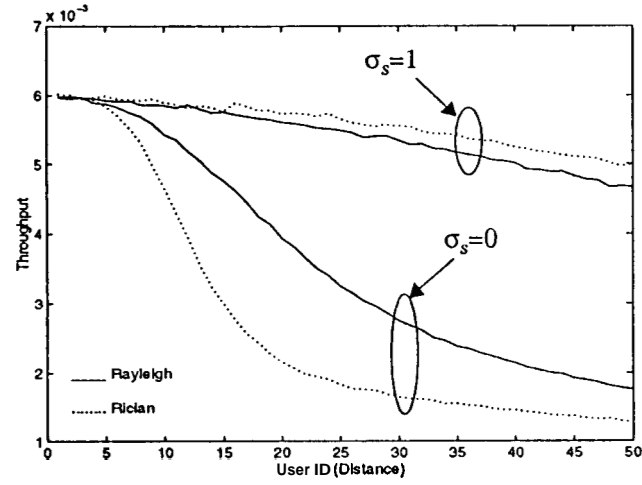

Fig. 6. Throughput of each user under 4 channel models. $p_0 = 0.006$, $q = 0.12$.

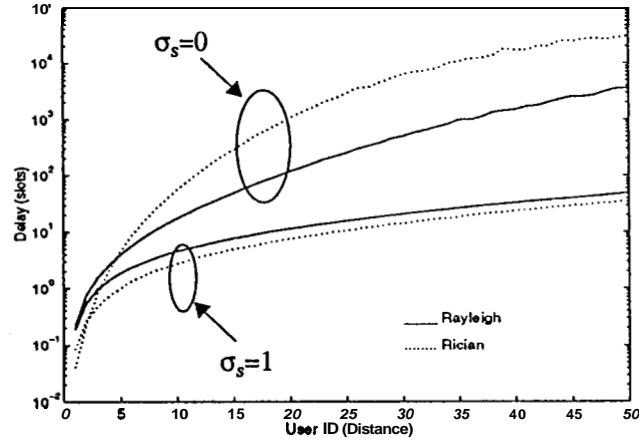

Fig. 7. Delay of each user under 4 channel models. $p_0 = 0.006$, $q = 0.12$.

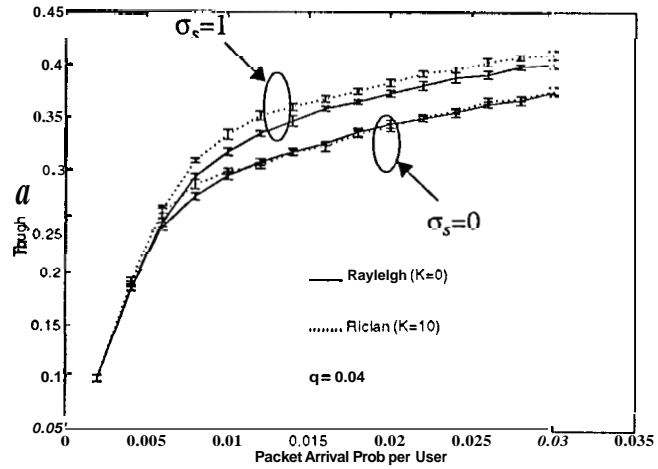

Fig. 8. Network throughput as a function of packet arrival probability p_0 . The retransmission probability $q = 0.04$.

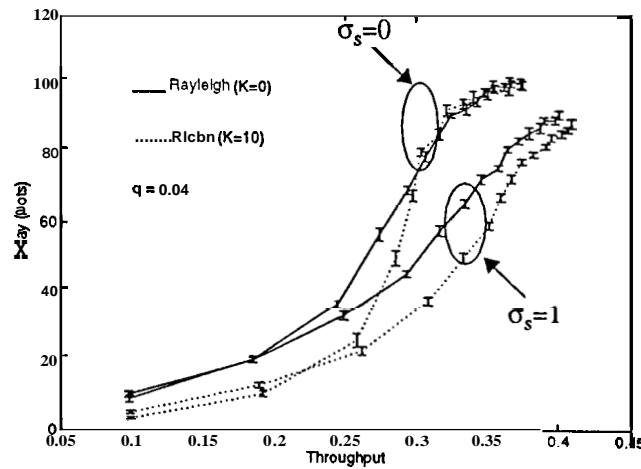

Fig. 9. Throughput-delay performance of 4 channels. The retransmission probability $q = 0.04$.

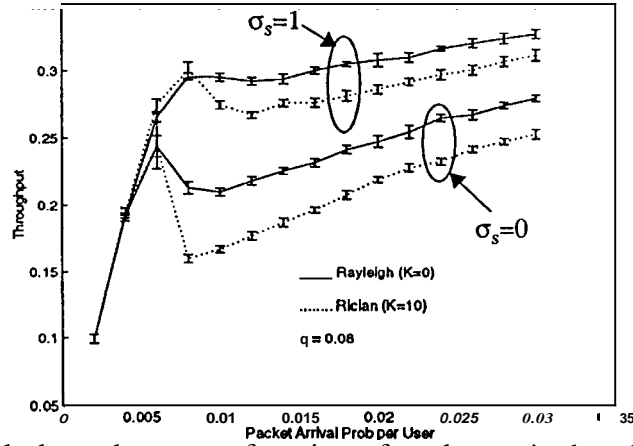

Fig. 10. Network throughput as a function of packet arrival probability p_0 . The retransmission probability $q = 0.08$.

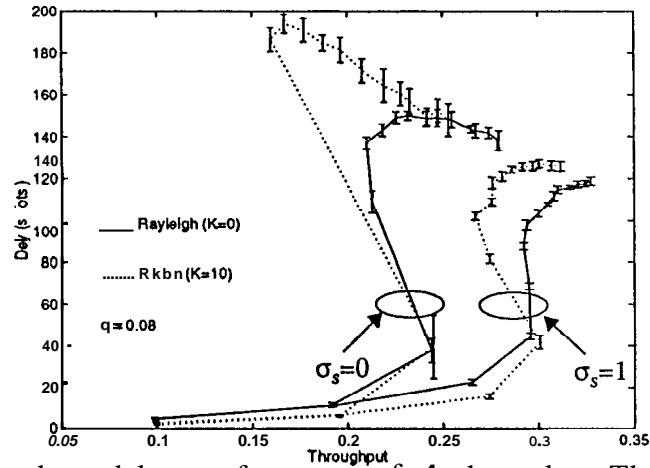

Fig. 11. Throughput-delay performance of 4 channels. The retransmission probability $q = 0.08$.

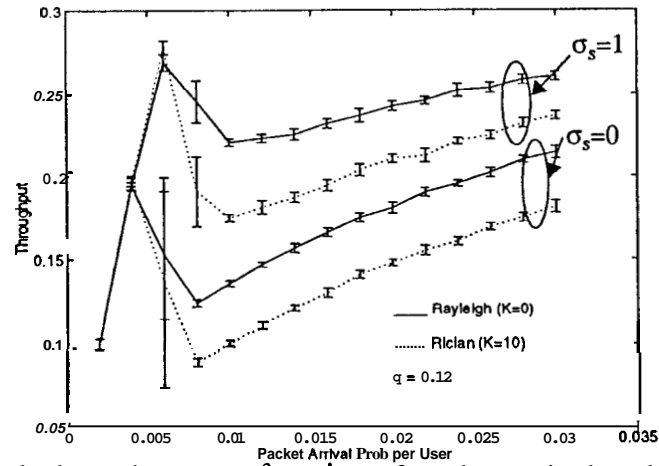

Fig. 12. Network throughput as a function of packet arrival probability p_0 . The retransmission probability $q = 0.12$.

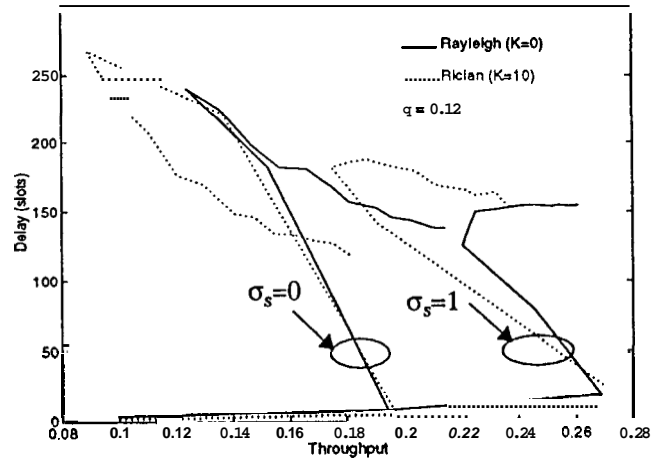

Fig. 13. Throughput-delay performance of 4 channels. The retransmission probability $q = 0.12$.

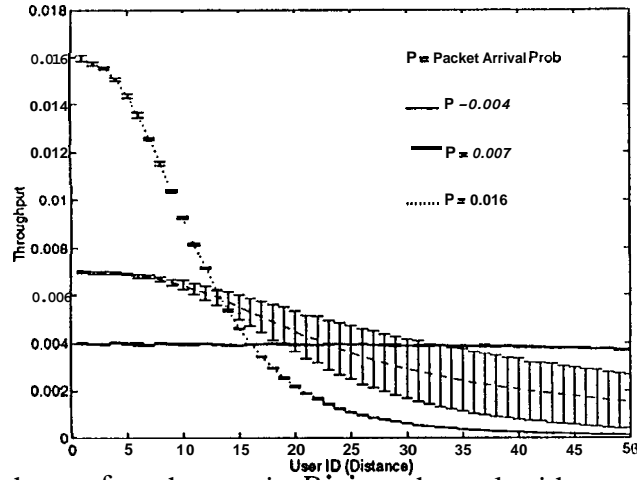

Fig. 14. Throughput of each user in Rician channel with $q = 0.08$. Network throughput is 0.2 approximately.

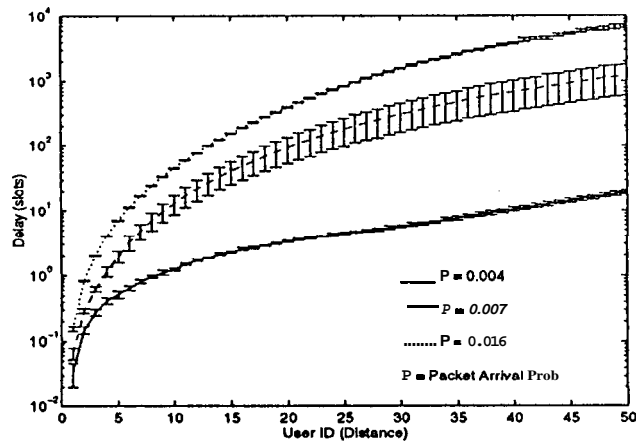

Fig. 15. Delay of each user in Rician channel with $q = 0.08$. Network average delay for $p_0 = 0.004, 0.007,$ and 0.016 are 6.1, 125, and 191, respectively.

4. Conclusion

A conceptual simulation framework is developed for mobile radio communications networks for **ATMIS**. By abstracting the shared radio channel by a simulation kernel, the interaction between communication entities (such as vehicles and **base** stations) can be modeled at different levels of detail. We have discussed the various levels of detail of the component models and the trade-off between accuracy and simulation run time.

A baseline simulation model has been used to investigate the impact of channel models and user locations on system and user performance. The simulation results show that system performance is not sensitive to channel parameters when the channel load is light. However, the difference in system performance for different channel models will become more significant when channel load is heavy. **This** implies that it is possible to use simple channel model (i.e., faster simulation) and get sufficiently accurate system performance under light load condition.

With the proposed conceptual framework, more experiments can be performed to find other key parameters that will impact the system performance most. With that knowledge, more detailed trade-off analysis and system parameter optimization can be done accordingly.

5. References

- [1] C. Lau and C. Leung, "Capture models for mobile packet radio networks," *Proc. Int. Conf. Commun., ICC*, Atlanta, Apr. 1990, pp. 1226-1230.
- [2] J. C. Arnbak and W. V. Blitterswijk, "Capacity of slotted ALOHA in Rayleigh-fading channels," *J. SAC*, vol. 5, no. 2, pp. 261-269, Feb. 1987.
- [3] I. M. I. Habbab et al, "ALOHA with capture over slow fading radio channels with coding and diversity," *J. SAC*, vol. 7, no. 1, pp. 79-88, Jan. 1989.
- [4] C. V. D. Plas and J.-P. M. G. Linnartz, "Stability of mobile slotted ALOHA network with Rayleigh fading, shadowing, and near-far effect," *Trans. Veh. Techn.*, vol. 39, no. 4, pp. 359-366, Nov. 1990.
- [5] K. Zhang and K. Pahlavan, "Relation between transmission and throughput of slotted ALOHA local packet radio networks," *Trans. Commun.*, vol. 40, no. 3, pp. 577-583, Mar. 1992.
- [6] H. H. Xia et al., "Radio propagation measurements and modelling for line-of-sight microcellular systems," *Proc. of Veh. Techn. Conf.*, 1992, pp. 349-354.
- [7] R.J.C. Bultitude et al., "Propagation characteristics on microcellular urban mobile radio channels at 910 MHz," *J. SAC*, vol. 7, no. 1, pp. 31-39, Jan. 1989.
- [8] J.-P. Linnartz, *Narrowband Land-Mobile Radio Networks*, Artech House, Boston, 1993, pp. 79.
- [9] W. Cremer et al., "Computer-Aided Design and Evaluation of Mobile Radio Local Area Networks in RTI/IVHS Environments," *Journal on Selected Areas in Commun.*, vol. 11, no. 3, pp. 406-421, Apr. 1993.

Publications Related to MOU 141

- A. “An Analytical Model for Multi-Group Slotted ALOHA with Capture” T-K. Liu, J.A. Silvester, and A. Polydoros, USC-CENG-94-29, November 1994.
- B. “A General Performance Model for Mobile Slotted ALOHA Networks with Capture”, T-K. Liu, J.A. Silvester, and A. Polydoros, *Proceedings of ICC95*, pp 1582-1586, June 1995 (also USC-CENG-94-31, November 1994.)
- C. “Performance Evaluation of R-ALOHA in Distributed Packet Radio Networks with Hard Real Time Communications”, Te-Kai Liu, J.A. Silvester, and A. Polydoros, *Proceedings of VTC95*, pp 554-558, July 1995 (also USC-CENG-94-30, November 1994.)
- D. “The Maximum Throughput and Maximum Balanced Throughput of Mobile Slotted ALOHA Networks”, T-K. Liu and J.A. Silvester, USC-CENG-95-24, December 1995.
- E. “Modeling Survey: The Relationship between Environments, Services, and Network Performance in Wireless Communications Networks”, T-K. Liu and J.A. Silvester, USC-CENG-96-01, January 1996, (revised version USC-CSI-96-03-01, March 1996).
- F. “Retransmission Control and Fairness Issues in Mobile Slotted ALOHA Networks with Fading and Near-Far Effects”, T-K. Liu, J.A. Silvester, and A. Polydoros, to appear in *Journal of Wireless Networks*, (submitted January 1996, accepted July 1996) (also USC-CENG-96-02, January 1996.)
- G. “Congestion Control Policies for Quality of Service Guarantees in Wireless CDMA Networks supporting Personal Communication Services”, T-K. Liu and J.A. Silvester, submitted to *IEEE Journal on Selected Areas in Communications*, (submitted August 1996.)