

Lawrence Berkeley National Laboratory

Lawrence Berkeley National Laboratory

Title

A SIMPLIFIED RF POWER SYSTEM FOR WIDEROE-TYPE LINACS

Permalink

<https://escholarship.org/uc/item/9p52973r>

Author

Fugitt, J.

Publication Date

2010-03-18

Peer reviewed



Lawrence Berkeley Laboratory

UNIVERSITY OF CALIFORNIA

Engineering & Technical Services Division

Presented at the IEEE Particle Accelerator Conference,
Washington, D.C., March 11-13, 1981

A SIMPLIFIED RF POWER SYSTEM FOR WIDEROE-TYPE LINACS

J. Fugitt, D. Howard, F. Crosby, R. Johnson,
M. Nolan, and G. Yuen

MASTER

March 1981



REPRODUCTION OF THIS DOCUMENT IS UNLIMITED

A SIMPLIFIED RF POWER SYSTEM FOR WIDEROE-TYPE LINACS*

J. Fugitt, D. Howard, F. Crosby, K. Johnson, M. Nolan, G. Yuen**

Summary

The RF system for the SuperHILAC injector linac was designed and constructed for minimum system complexity, wide dynamic range, and ease of maintenance. The final amplifier is close coupled to the linac and operates in an efficient semilinear mode, eliminating troublesome transmission lines, modulators, and high level regulators. The system has been operated at over 250 kW, 23 MHz with good regulation. The low level RF electronics are contained in a single chassis adjacent to the RF control computer, which monitors all important operating parameters. A unique 360° phase and amplitude modulator is used for precise control and regulation of the accelerating voltage.

Main Amplifier

A semilinear operating mode was chosen for the RF system rather than the traditional Class C stage for reasons of economy and bandwidth. While it is true that the Class C stage has high efficiency in converting DC to RF, in a multimode accelerator system that must be pulse height agile over a 2:1 range, the overall system efficiency turns out to be lower than with a Class B stage. This is because of the power lost in the series modulator required for the Class C stage.

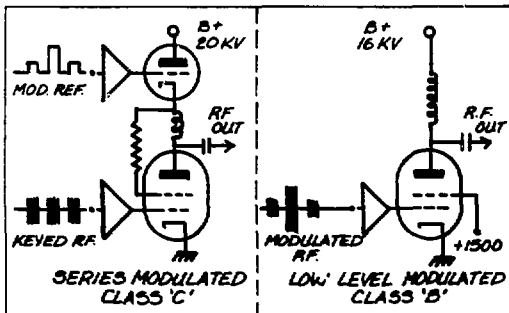

The system complexity and overall efficiency can be improved a little by keeping a Class C operating point while screen modulating the output stage. This keeps efficiency a little higher than Class B but still requires a fairly large modulator, and it is quite difficult to get better than about 100 kHz bandwidth, especially with a large screen bypass capacitor. By carefully selecting the operating point not for maximum linearity but for reasonable efficiency and good dynamic range, the efficiency of the linear amplifier can be significantly improved.

The amplifier design chosen uses an EIMAC 4C100K/8959 biased near cutoff, with a small amount of grid leak resistance to allow additional bias, and conduction angle reduction at full drive. This tube can deliver over 200 kW in this mode, giving us ample reserve to supply resonator losses, and an expected 20 to 40 kW of beam loading. Running at 30% duty factor, we will have ample plate dissipation even when supplying reactive power to the beam loss. This gives us maximum flexibility for multibeam operations and provides at least a decade of additional

frequency response over high level modulation. This additional bandpass will be useful to overcome beam-induced RF instabilities, especially while running "noisy" beams (PIG sources having typical 10-100 kHz modulation components). In normal operation we will run at reduced filament voltage to extend tube life. It has been our experience that with filament voltage reduced to about 85% rated value, we can expect over 50K hours (5-7 years) life on these type tubes.

The final amplifier is directly coupled to the Wideroe structure with only a matching network (no plate resonator) using a loop in the middle stub line, eliminating transmission lines with their inherent sparking and mode problems.

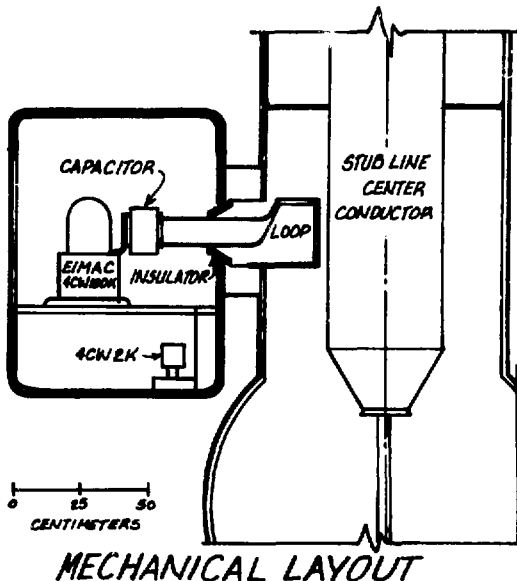

The voltage induced in the loop is given by

$$V = (\mu_0 AI / 2\pi R) \cos 2\pi Z / \lambda$$

where I = current at the stub line short

A = loop area

R = radius from stub line center to loop center

Z = distance from stub line short to loop center

This voltage, in our case, is about 5 kV for a reasonable loop size. Because this level does not match well with our final amplifier, a matching network is formed using the output capacity of the final tube and the inductance of the drive loop. This is adjusted to cause the voltage at the final tube output to surge by a factor of three. With this voltage of 15 kV, good impedance match for power transfer is obtained. Final matching to the Wideroe is done by rotating the coupling loop. The DC is shunt fed to

*This work was supported by the Director, Office of Energy Research, Office of High Energy and Nuclear Physics, High Energy Physics Division, U.S. Dept. of Energy under contract W-7405-ENG-48.

**Lawrence Berkeley Laboratory, University of California, Berkeley, CA 94720.



Wideroe accelerator and final amplifier
CBB 812-1743

the amplifier through a 2 stage air insulated RF choke.

The DC blocking capacitor is a vacuum ceramic unit with cooling on each end. The anode end is conduction cooled by a heavy copper strap heat-sinked to the 4CW100K anode water jacket, while the output end is water cooled by the same water circuit that cools the coupling loop.

The power supply for the final stage is a stand alone, 6 phase, oil filled unit with taps to select 10, 15, 18, and 20 kV operation. The unit is rated at 320 kW. The primary power is taken directly from Bank 71, 480 V buss. The output is connected to a small capacitor bank of about 100 μ f for despiking and pulse flattening. Using a separate stand alone power supply for the wideroe gives us maximum flexibility in operation, and is very cost effective.

Neutralization is accomplished quite simply by a capacity shoe placed near the anode and connected to the 180° end of the 1/2 wave grid resonator. The adjustment is noncritical and easy to make when tube replacement is required. Stability and band width are improved by grid swamping resistors spaced equally around the tube socket.

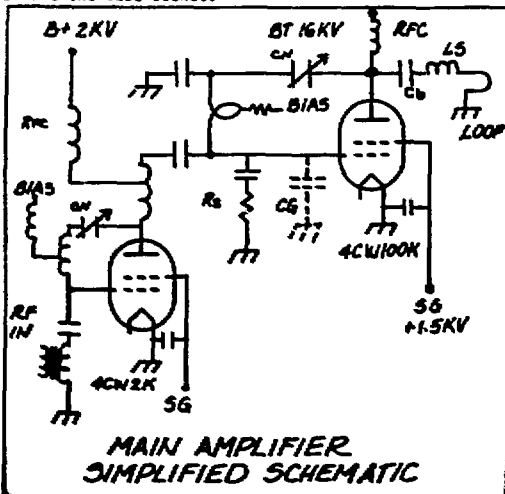

Driver Amplifier

The driver is an EIMAC 4CW2000 running class AB₁ and PI coupled to the 4CW100K. The low level stage is a 10 W solid state unit.

Frequency Regulator

The RF frequency control uses existing HILAC designs and components with only very minor modifications to adapt to the 23 MHz frequency. The detector and servo system are a 2 wide HIL module complete with a 200 W motor drive amplifier. The tuner itself penetrates the vacuum with a single "O" ring seal, and is liquid cooled. It is driven with a low inertia printed armature servo motor and wave motion zero backlash gear reducer of the same design that has proven very reliable on the HILAC.

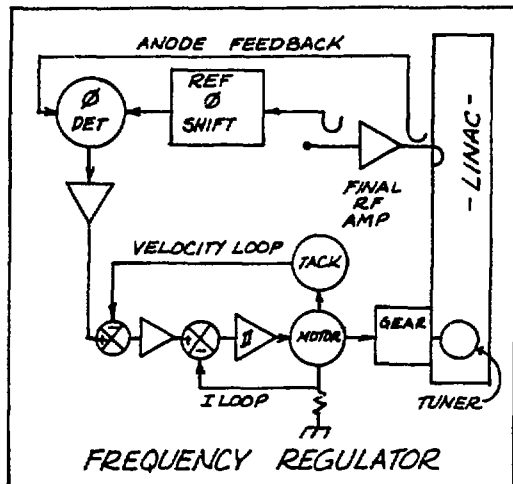

Low Level RF System

Phase and amplitude modulation are accomplished at low level where bandwidth is limited only by the driver interstage band pass (typically several Mhz).

RF Phase Regulator

The 23 MHz RF source for the preinjector system is derived from the HILAC 70 MHz master oscillator with a phase locked frequency divider. The +10 dbm RF output is then phase shifted by 2 precision complex phasor modulators (CPH) to be used as the accelerator RF phase reference voltage and the offset RF drive voltage.

The CPH uses 2 double balanced transistor modulators to linearly modulate the quadrature RF drive voltages with respect to the two DC reference voltages, $r \cos \theta$ and $r \sin \theta$. The modulator outputs are summed in phase and buffered to provide precision RF output phase θ .

The DC reference voltages $r \cos \theta$ and $r \sin \theta$ may be sourced, either from computer controlled DAC's or in local control, from the front panel sine-cosine pots.

The "HF ref." is compared with the accelerator RF feedback ("HF.FB.") with a standard double balanced mixer and the DC output is used to drive a fast quadrature varactor phase modulator for closed loop frequency regulation.

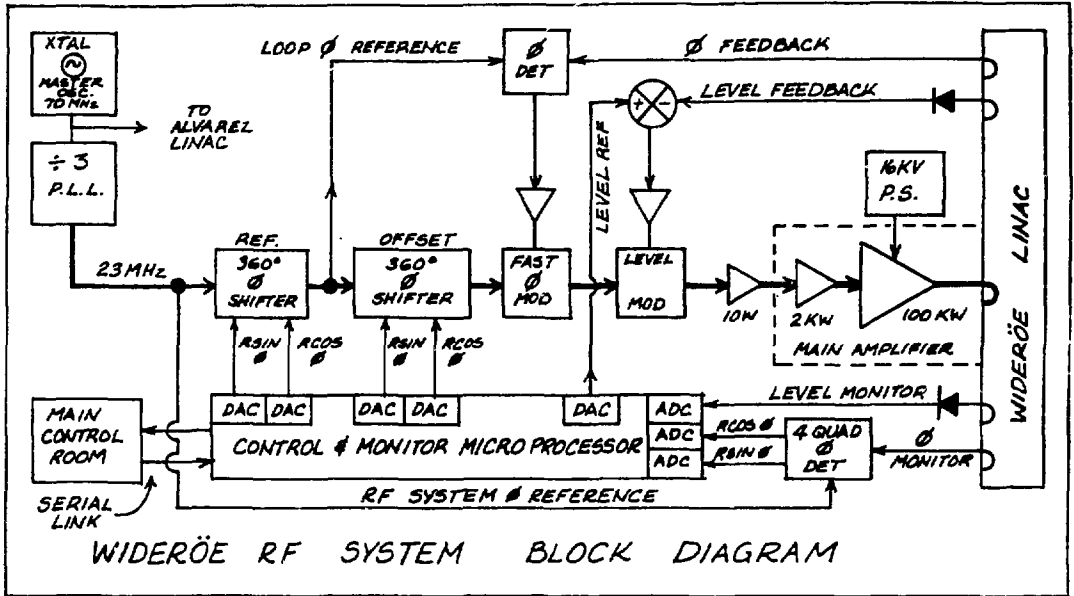

Gradient Regulation

The closed loop level regulator uses a precision accelerator mounted detector to measure RF voltage. This is compared with the level reference DC signal and used to drive the fast RF level modulator (one quadrant RF multiplier). The buffered modulator output, +10 dbm, is the source for the RF amplifier drive chain.

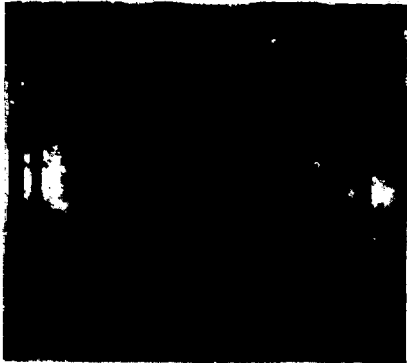

Low level control chassis showing built-in test points

CBB 812-1741

Maintainability

The entire RF system is designed for minimum accelerator down time. This is accomplished in several ways. 1. By significantly reducing system complexity as compared with traditional accelerator RF systems. 2. By providing numerous system test points, many of which are monitored and evaluated in real time by the RF control microcomputer. In many cases, this on line self checking can point to potential problems that can be corrected during routine maintenance periods. 3. Many system tune up adjustments are eliminated by the semibroad band design (no grid, anode, or neutralizer adjustments).

RF Control Computer

The entire RF system is controlled by a dedicated microcomputer system. The computer is mounted adjacent to the low level RF system, and is used to control offset and reference levels, Boolean control signals (on, off, raise, lower, etc.) and to monitor output and performance values (accelerating gradient, plate current, phase angle, etc.) as well as looking at a large number of Boolean input signals, out of range alarms, low and high limits, etc. Of course, the personnel and equipment protection interlocks are implemented in hardware. The RF system has been tested at over 250 kw output and 30 duty factor, and has very good regulation and dynamic range.

DISCLAIMER

This book was prepared as an account of work sponsored by an agency of the United States Government. Neither the United States Government nor any agency thereof, nor any of their employees, makes any warranty, express or implied, or assumes any legal liability or responsibility for the accuracy, completeness, or usefulness of any information, apparatus, product, or process disclosed, or represents that its use would not infringe privately owned rights. Reference herein to any specific commercial product, process, or service by trade name, trademark, manufacturer, or otherwise, does not necessarily constitute or imply its endorsement, recommendation, or favoring by the United States Government or any agency thereof. The views and opinions of authors expressed herein do not necessarily state or reflect those of the United States Government or any agency thereof.